

8-2009

Estimating sediment yield of the upper reaches of the Benson Creek watershed by pond coring.

Michael Borchers 1968-
University of Louisville

Follow this and additional works at: <https://ir.library.louisville.edu/etd>

Recommended Citation

Borchers, Michael 1968-, "Estimating sediment yield of the upper reaches of the Benson Creek watershed by pond coring." (2009).
Electronic Theses and Dissertations. Paper 128.
<https://doi.org/10.18297/etd/128>

This Master's Thesis is brought to you for free and open access by ThinkIR: The University of Louisville's Institutional Repository. It has been accepted for inclusion in Electronic Theses and Dissertations by an authorized administrator of ThinkIR: The University of Louisville's Institutional Repository. This title appears here courtesy of the author, who has retained all other copyrights. For more information, please contact thinkir@louisville.edu.

Estimating Sediment Yield of the Upper Reaches of the Benson Creek
Watershed by Pond Coring

By

Michael Borchers
B.S., The Ohio State University, 1994
B.S., University of Louisville, 2009

A Thesis
Submitted to the faculty of the
University of Louisville
J.B. Speed School of Engineering
In Partial Fulfillment of the Requirements
for the Professional Degree

MASTER OF ENGINEERING

Department of Civil and Environmental Engineering

August 2009

ESTIMATING SEDIMENT YIELD OF THE UPPER REACHES OF THE
BENSON CREEK WATERSHED BY POND CORING

Submitted by: _____

Michael Borchers

Thesis Approved on

(Date)

by the Following Reading and Examination Committee:

Dr. Arthur C. Parola, Thesis Director

Dr. D. Joseph Hagerty

Dr. James C. Watters

ACKNOWLEDGEMENTS

I would like to give thanks to Dr. Hagerty, Dr. Parola, and Dr. Watters for agreeing to serve on my thesis committee and for their advice and suggestions.

Additional thanks are given to the University of Louisville Stream Institute staff who offered assistance and advice. Special thanks goes to Dr. Croasdaile for the initial idea of using ponds as sediment traps and for guidance and advice throughout the project. William Vesely supplied an initial design for a corer and helpful suggestions on the coring process. Charles Davis Murphy provided assistance in the field and lab. Clayton Mastin provided tremendous help in the field, without which this project would never have happened, go “B” team.

The landowners who generously gave access to their land also are deserving of appreciation.

Above all, I would like to thank my wife, Veronica, for her unwavering support and my, two sons Carson and Liam, for providing tremendous amounts of motivation.

ABSTRACT

A potential source of fine grained suspended sediments in a stream system is the upper hillslopes of the drainage. Quantifying the sediment produced and transported to a stream from these hillslopes is challenging because of the complex nature of sediment production and transport. Therefore, a field method utilizing farm ponds as sediment catchments was developed to relate entrapped sediment volume and weight to hillslope erosion yields.

The study area was located in the western portion of the Benson Creek watershed in the Bluegrass Region of central Kentucky. The soil is highly erosive because it is residuum from exposed friable shale (Eden Shale). This highly erosive nature creates high concentrations of fine-grained suspended sediments in surface water.

The rate of sediment produced from the hillslopes and transported to the stream networks was estimated by dividing the total weight of sediment entrapped by a pond by its age and drainage area. Pond sediment volumes were measured via a bathymetric survey, and the weight was estimated in three different ways. First, the average bulk density from a pond core was multiplied by the estimated volume of the pond sediment. Secondly, a distributed bulk density relationship between core density and core length was developed. From this relationship, new density values were calculated and multiplied by the sediment volume, which resulted in a total weight of sediment. Lastly, after removing all of the unconsolidated material from the samples, a distributed bulk

density relationship was developed as above. The various calculated sediment yields then were compared to results from a Revised Universal Soil Loss Equation v.2 model.

TABLE OF CONTENTS

APPROVAL PAGE.....	ii
ACKNOWLEDGEMENTS.....	iii
ABSTRACT.....	iv
LIST OF TABLES.....	viii
LIST OF FIGURES.....	ix
I. INTRODUCTION.....	1
II. BACKGROUND.....	3
A. Site Location.....	3
B. Geology.....	3
C. Soil Survey Data.....	8
D. Geographic Information System Data.....	10
III. PROCEDURES.....	11
A. Site Selection.....	12
B. Site Surveys.....	20
C. Coring.....	25
D. Pond Core Examination.....	29
E. Volume of Pond Sediments.....	34
F. Estimated Weight of Pond Sediment.....	36
1. Average Bulk Density.....	36
2. Distributed Bulk Density.....	36
3. Distributed Bulk Density, Minus Unconsolidated Material.....	40
G. Average Sediment Deposition Rate.....	44

H. RUSLE2 Study.....	45
IV. RESULTS	50
V. CONCLUSIONS.....	63
REFERENCE	65
APPENDIX I. POND BULK DENSITY INFORMATION.....	67
APPENDIX II. SOILS DATA FOR EACH SITE.....	78
APPENDIX III. DETAILS OF SITE LAYOUTS.....	105
VITA.....	121

LIST OF TABLES

TABLE I – Soil types for each site9

TABLE II – Descriptions of soils and parent material9

TABLE III – Site parameters16

TABLE IV – Bulk density of cores34

TABLE V – Site summary information for RUSLE2 model48

TABLE VI (a - b) – Split core results and length reduction between total core sediment and sediment minus unconsolidated material51, 52

TABLE VII – Determination of length reduction factors for removal of unconsolidated material from each pond53

TABLE VIII – Volumes of various pond sediments54

TABLE IX – Weight of pond sediments from various bulk density distribution methods ...55

TABLE X – Descriptive statistics for length/density correlations56

TABLE XI – Comparisons of hillslope sediment yield results for the different rate determination methods.....57

TABLE XII – Summary of bulk density and sediment transport results from the various analyses for each pond59

TABLE XIII (a-b) – Bulk density summary information, Hickory Grove Pond.....68-69

TABLE XIV – Bulk density summary information, Sullivan Pond70

TABLE XV – Bulk density summary information, Crawford Pond71

TABLE XVI – Bulk density summary information, Wilson 1 Pond.....72

TABLE XVII - Bulk density summary information, Wilson 2 Pond73

TABLE XVIII - Bulk density summary information, Gunn Pond74

TABLE XIX - Bulk density summary information, McDivitte Pond75

TABLE XX - Bulk density summary information, Perry 1 Pond.....76

TABLE XXI - Bulk density summary information, Perry 2 Pond77

LIST OF FIGURES

FIGURE 1 - Location of Benson Creek Watershed.....	3
FIGURE 2 - Regional surface geology near the Benson Creek watershed.	6
FIGURE 3 - Percent slope map of the Benson Creek watershed illustrating the highly dissected and dendritic drainage pattern in the western portion of the watershed (Eden Shale Belt).....	7
FIGURE 4 - Soil map of typical site, Crawford Pond.....	10
FIGURE 5 - Limits of the Benson Creek watershed, with site locations.	15
FIGURE 6 - Looking up-stream of Crawford Pond illustrating lack of up-stream channel or gully development.	16
FIGURE 7 - Mid-summer hillslope ground cover, low impact, Crawford Pond.	17
FIGURE 8 - Mid-summer medium impact hillslope erosion, Hickory Grove Pond.	17
FIGURE 9 - Mid-summer high impact hillslope erosion produced by overgrazing, Sullivan.....	18
FIGURE 10 - Orthographic and topographic detail of typical site, Crawford Pond, illustrating pond location relative to hillslopes and top of drainage.....	18
FIGURE 11 - Looking up-stream from dam at sediment fringe, Crawford Pond.	19
FIGURE 12 - Crawford Pond sediment fringe, looking down-stream towards dam.....	19
FIGURE 13 - Typical valley profile, Crawford Pond.....	21
FIGURE 14 - Typical pond cross section with water surface and entrapped sediment ...	22
FIGURE 15 - Typical pond survey layout with cross sections, valley profile, pond outline, and sediment fringe, Crawford Pond.	23
FIGURE 16 - Field Personnel performing bathymetric survey.....	24
FIGURE 17 - Taking sediment depth measurements as part of the bathymetric survey, note steel tape used to position sediment probe.....	24
FIGURE 18 - Close up detail of corer.	25
FIGURE 19 - Taking a core.....	27
FIGURE 20 - Operator extracts corer and prepares to transport it to shore.	27
FIGURE 21 - Operator prepares to extract core into cradle	28
FIGURE 22 - Cores collected at Hickory Grove Road, ready for transport.....	28
FIGURE 23 - Photo of split pond core exhibiting the three sediment zones and internal structures.....	31
FIGURE 24 - Land Desktop Terrain Editor surfaces used to calculate volume of entrapped sediment.	35
FIGURE 25 - Plot of core density normalized to length showing power relationship of length to density versus core length.....	39
FIGURE 26 - Typical cross section with different sediment layers.	41

FIGURE 27 – Correlation between length/density ratio and core length, for samples without unconsolidated sediment.....	43
FIGURE 28 - Frequency of depositional rates	45
FIGURE 29 - Location of representative slope profiles	49
FIGURE 30 - Valley cross section with representative slopes and lengths.....	49
FIGURE 31 - Regression analysis of normalized density for pond cores	60
FIGURE 32 - Regression analysis of normalized density for pond cores, with their unconsolidated layer removed	61
FIGURE 33 - Summary graph of calculated erosion rates.	62
FIGURE 34 - Soils map of Hickory Grove site.....	79
FIGURE 35 - Soils map of Sullivan site.....	80
FIGURE 36 - Soils Map of Crawford site.	81
FIGURE 37 (a,b) - Soils map for sites Wilson 1 and 2.	82
FIGURE 38 - Soils map for Gunn site.....	84
FIGURE 39 - Soils map for McDevitte Site.....	85
FIGURE 40 - Soils map for Perry 1 site.	86
FIGURE 41 - Soils map for Perry 2 site.....	87
FIGURE 42 - Legend for soils maps, all sites.	88
FIGURE 43 - Orthographic and topographic layout of Sullivan pond site.	106
FIGURE 44 - AutoCAD layout of Sullivan site.	107
FIGURE 45 - Orthographic and topographic layout of Crawford pond site.	108
FIGURE 46 - AutoCAD layout of Crawford Pond site.....	109
FIGURE 47 - Orthographic and topographic layout of Wilson 1 and 2 pond sites.....	110
FIGURE 48 - AutoCAD layout of Wilson1 site.....	111
FIGURE 49 - AutoCAD layout of Wilson2 site.....	112
FIGURE 50 - Orthographic and topographic layout of Gunn pond site.....	113
FIGURE 51 - AutoCAD layout of Gunn site.....	114
FIGURE 52 - Orthographic and topographic layout of McDevitte pond site.....	115
FIGURE 53 - AutoCAD layout of McDevitte site	1166
FIGURE 54 - Orthographic and topographic layout of Perry 1 pond site.....	117
FIGURE 55 - AutoCAD layout of Perry 1 site.....	118
FIGURE 56 - Orthographic and topographic layout of Perry2 pond site.....	119
FIGURE 57 - AutoCAD layout of Perry 2 site.....	120

I. INTRODUCTION

Surface water quality became a major concern in the United States in the 1970s. With the passage of the Clean Water Act in 1974, the United States Environmental Protection Agency began assessing surface water quality throughout the country. These assessments have determined that siltation from fine-grained sediments is a major cause of pollution in surface water. Sediment reduction is a goal of many governmental agencies (EPA 2008b).

Fine-grained sediments consist of silt to clay-sized particles, smaller than 0.075 mm in equivalent diameter. The mechanism producing these sediments usually is the erosion of hillslopes and bottom lands. Hillslope erosion is produced from sheet flow and soil raindrop interactions in which water movement concentrates to form rills and gullies. Bottom-land erosion is produced from mass wasting of stream banks generated by undercutting and particle removal associated with shear stresses in excess of soil shear strength (Knighton 1998).

A problem in limiting suspended sediments in surface water is the difficulty in determining the sources and respective sediment production rates within a watershed. Measuring the amount of suspended sediment in a stream produced from the erosion of a hillslope is challenging because of the dynamic nature of sediment transport and deposition. As hillslopes are eroded and the sediment is transported downhill, some of this sediment is deposited on the lower reaches of the hillslopes. Sediments transported to the gully/channel network merge with gully/channel sediments, making an accurate

differentiation of the hillslope sediment from the channel sediment difficult. This study examines sediment supply to gullies and channel networks from the erosion of hillslopes. A method of measuring hillslope sediments after they are eroded from sources areas and before they are incorporated with gully/channel sediments was developed.

The amount of sediment produced by a particular hillslope and transported to rills and gullies was estimated by utilizing small farm ponds at the base of hillslopes and above the development of a gully/channel network as sediment catchments. The volume of sediment collected in a pond was measured via a bathymetric survey. By multiplying the measured volume of pond sediment by bulk densities determined from sediment cores, the weight of sediment impounded could be estimated. This estimated weight then was divided by the drainage area of the pond and by the pond age to calculate a rate of pond sediment deposition in tons/acre/year. The rate of pond sediment deposition was assumed equal to the amount of sediment subsequently transported into the gully/channel network.

This study took place in the Benson Creek drainage area in central Kentucky. The western portion of the drainage area displays relatively high erosion rates and is classified by the Environmental Protection Agency as impaired because of the high levels of suspended sediments.

Nine farm ponds were selected and mapped. Sediments were obtained from cores taken from the pond bottoms. Sediment rates were estimated from the data according to the method described previously and were compared to erosion yield rates estimated by the Revised Universal Soil Loss Equation Version 2 (ASCE 2008).

II. BACKGROUND

A. Site Location

The Benson Creek watershed is located in the Bluegrass Region of central Kentucky, FIGURE 1, and Benson Creek drains into the Kentucky River in Frankfort. The drainage basin is approximately 100 square miles in area.



FIGURE 1 - Location of Benson Creek Watershed

B. Geology

Hillslope erosion is influenced heavily by the lithology of the underlying bedrock. As bedrock weathers, soils and potential sediments are produced.

The surface strata of the Benson Creek watershed, as seen in FIGURE 2, consists of two formations with distinct erosional patterns. The strata exposed at the surface of the western two-thirds of the watershed primarily are composed of the Lower Clays Ferry Formation, a portion of which was previously described as the Eden Shale Belt (Davis 1927), a highly erodible formation. The eastern portion of the Benson Creek network drains an area dominated by Lexington Limestone, which is relatively resistant to erosion.

The Lower Clays Ferry Formation is a comparatively weak formation of shale and limestone (Wilson 1941). This weakness against erosive mechanisms results in a highly dissected dendritic drainage pattern with sharp ridges and V-shaped valleys with high amounts of soil erosion (Davis 1927).

The Clays Ferry Formation, 90 to 300 feet thick, is composed of interbedded limestone, shale, and minor siltstone strata. The limestone and shale occur in about equal amounts, while the siltstone accounts for only a small percentage of the formation and is more abundant near the top, especially near the contact with the Garrard Siltstone. The limestone is mostly very fossiliferous and occurs in regular beds commonly two to six inches thick (Cressman and Peterson 2001).

The shale commonly is sparsely fossiliferous and generally occurs in beds two to six inches thick. The shale is medium-gray and weathers to brownish-yellow clayey soil that contrasts with the dark-brown soil of underlying units. The shale beds commonly have sharp contacts with the limestone beds (Cressman and Peterson 2001).

The Clays Ferry Formation intertongues northward on a small scale with the Kope Formation across a broad zone that trends roughly east-west. The Point Pleasant Tongue

of the Clays Ferry Formation is lithologically similar to the main body of the Clays Ferry Formation and extends northward beneath the Kope Formation. Both the Clays Ferry and the Kope intertongue in part with the Lexington Limestone.

The Lexington Limestone exposed in the eastern portion of the Benson Creek watershed is comprised mainly of fossiliferous limestone 200-220 feet thick at its contact with the Clays Ferry Formation. The limestone is prone to the formation of karst terrain, tending to weather chemically by solution, resulting in low sediment generation (Cressman and Peterson 2001).

The Garrard Siltstone occurs above the Clays Ferry strata (locally recognized as the Kope) in the southeastern part of the main outcrop area of the uppermost part of the Clays Ferry Formation (Cressman and Peterson 2001; Moore 1975).

The transition between the Clays Ferry Formation and the Lexington Limestone is illustrated with a percent slope map in FIGURE 3. By color-coding the slope percentage or steepness of a hillslope, differences in erosion rates become apparent. Landscapes that are more susceptible to erosion down-cut faster resulting in steeper slopes. Thus, areas with high rates of erosion are represented by higher slope percentages. In this particular case, the Clays Ferry Formation in the western portion of the watershed has slope percentages in the range of 10 – 20 percent, where the Lexington Limestone has slope percentages of less than 7 percent.

Regional Surface Geology Near the Benson Creek Watershed

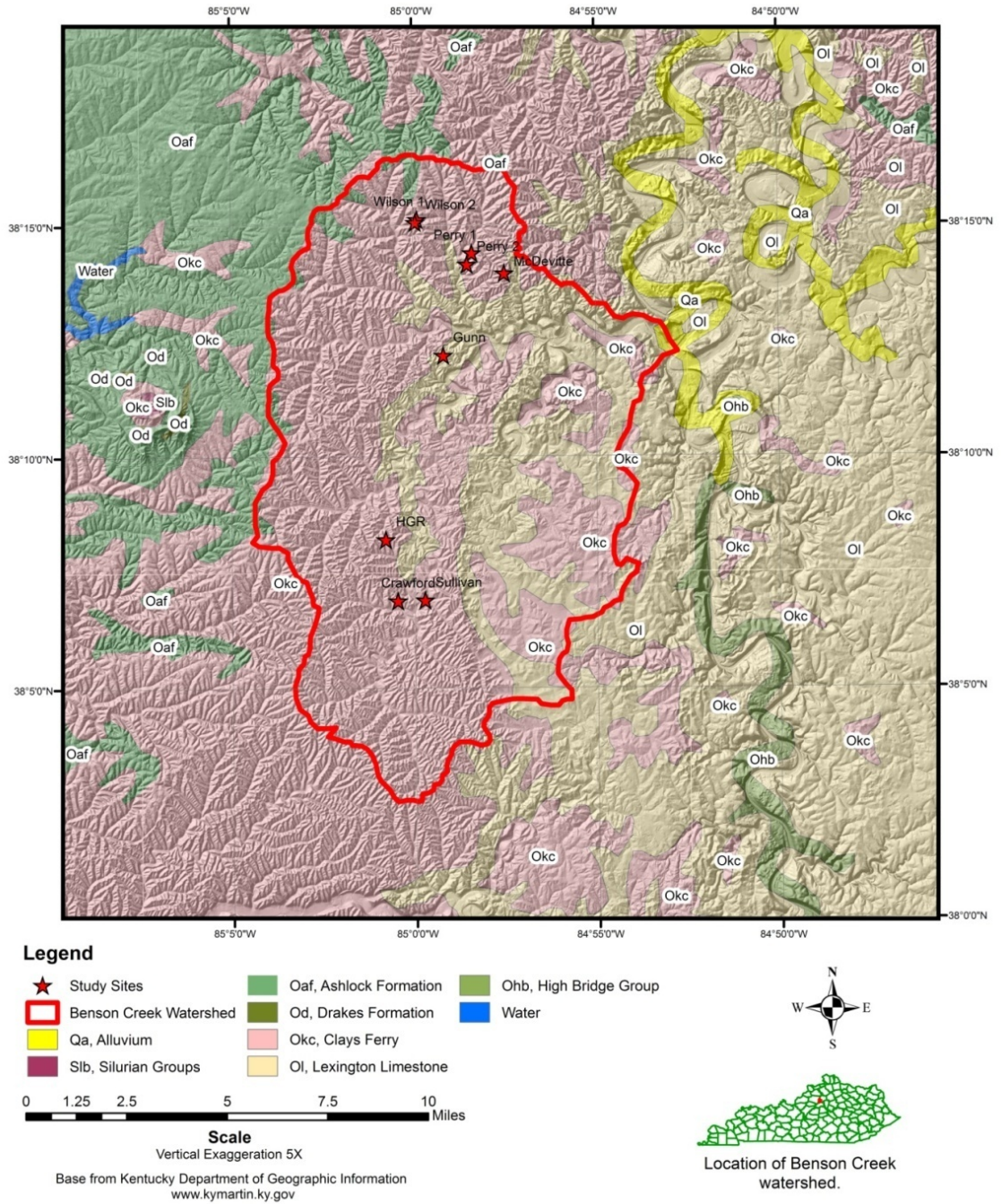

FIGURE 2 - Regional surface geology near the Benson Creek watershed (Crestman 2001, Peterson 2001, Moore 1975)

Percent Slope map of the Benson Creek Watershed

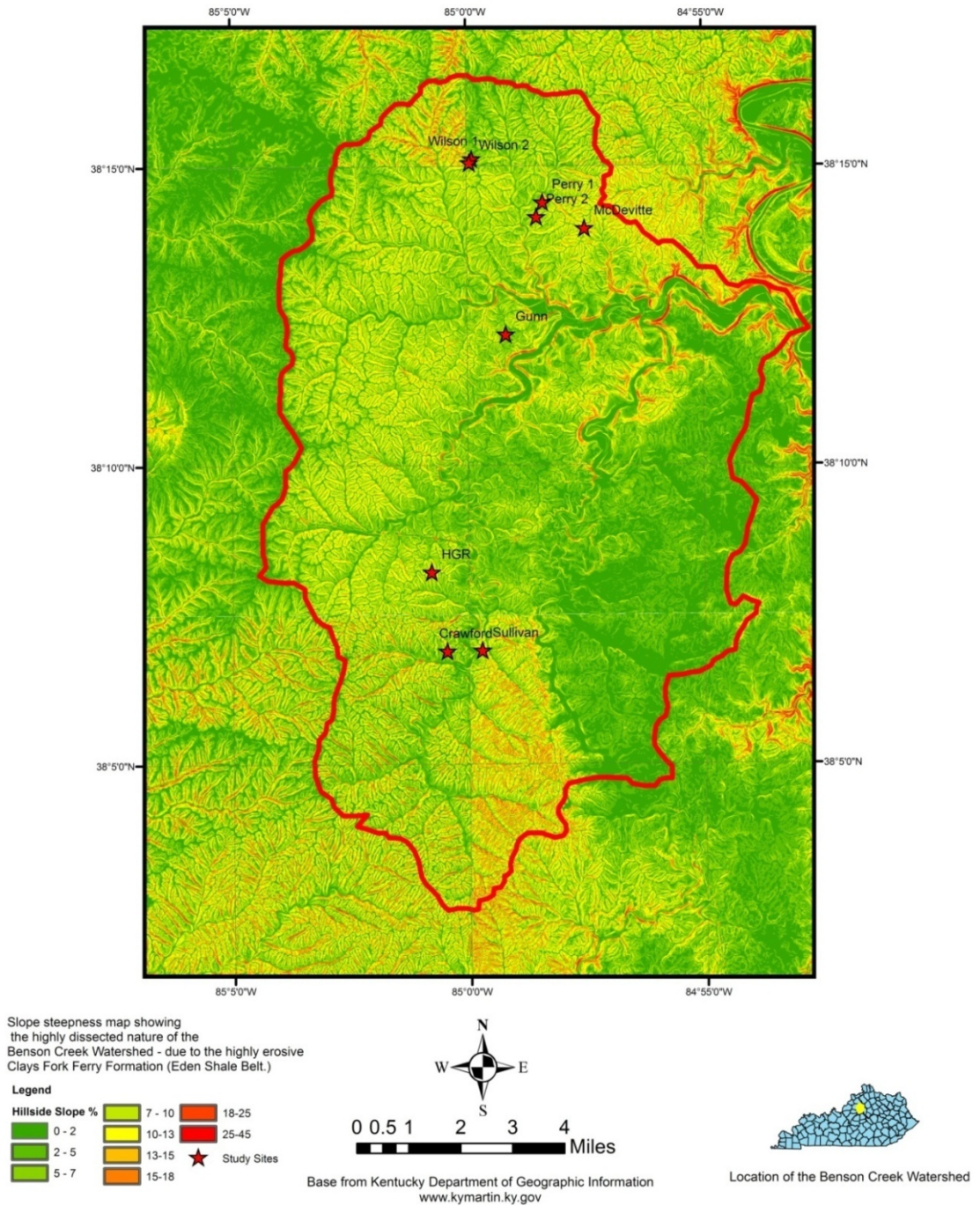

FIGURE 3 - Percent slope map of the Benson Creek watershed illustrating the highly dissected and dendritic drainage pattern in the western portion of the watershed (Eden Shale Belt)

C. Soil Survey Data

The soils of the Benson Creek watershed are generally yellow and often are thin (typically less than two feet thick). They typically have low fertility because their parent material (calcareous shales) disintegrate to plastic clays with low nutrient content. Under cultivation, slopes erode heavily with the soil carried to the valleys and streams, leaving thin slabs of limestone (more resistant to erosion than the interbedded shale layers) on the hillsides (Davis 1927 and Moore 1975).

The major soil types of the various sites included in this study are all very similar: calcareous clayey/silty residuum, primarily classified by landscape location (ridges, valley bottoms) or slopes (NRCS 2008). TABLE I lists the soil types found in the study area at each site, and TABLE II gives the classification and parent material for each soil type listed in TABLE I. FIGURE 4 shows an aerial photograph of one of the study sites, on which the soil types have been differentiated and named. The information on soil type and characteristics provided by the County Soil Reports of the Natural Resources Conservation Service is very valuable not only because of the technical content on soil classification, relative erodibility, parent materials and soil fertility, but because this information is available free of charge through local agents in all counties of all states in the United States.

TABLE I
SOIL TYPES FOR EACH SITE

Pond Name	Soil Type Major Component	percent of Site	Minor Components	percent of site
Crawford	FdD	67.3%	LwC	32.2%
Gunn	FdD	37.80%	LwC FdC	34.20% 28.00%
Hickory Grove	EfE	68.00%	EdC	32.00%
McDevitte	EfE	75.00%	EdC	25.00%
Perry 1	EfE	91.20%	EdC LwC	1.20% 7.60%
Perry 2	EfE	100.00%		
Sullivan	EfE	88.40%	FdC	11.60%
Wilson 1 and Wilson 2	EfE	62.70%	LwB LwC	30.80% 6.50%

TABLE II
DESCRIPTION OF SOILS AND PARENT MATERIAL

Symbol	Name	% Slope	Landform	Parent Material
EfE	Eden flaggy silt clay	15- 35%	Hills	Clayey residuum from weathered calcareous shale and limestone
EdC	Eden silty clay loam	6-15%	Ridges	Clayey residuum from weathered calcareous shale and limestone
LwB	Lowell silt loam	2-6%	Ridges and side slopes	Clayey residuum from weathered limestone and calcareous shale
LwC	Lowell silt loam	6-12%	Ridges and side slopes	Clayey residuum from weathered limestone and calcareous shale
FdC	Faywood silt loam	6-12%	Ridges	Clayey residuum from weathered limestone and shale
FdD	Faywood silt loam	12- 30%	Ridges	Clayey residuum from weathered limestone and shale



FIGURE 4 - Soil map of typical site, Crawford Pond (NRCS, 2008;
<http://websoilsurvey.nrcs.usda.gov/app/WebSoilSurvey.aspx>)

D. Geographic Information System Data Acquisition

Landform data for the various analysis methods developed in this study also were acquired via Geographic Information Systems (GIS). Data such as average slope angle and length values for the upper hillsides, drainage areas, watershed extents, soil types, and, surface geology/erosion potential were obtained from digitized sources. These data were used in selecting potential pond sites and as inputs for the Revised Universal Soil Loss Equation V. 2 (RUSLE2). Data were collected from the U.S. Department of Agriculture (NRCS 2008), U.S. Geological Survey Seamless Web server (USGS 2008), and the Kentucky Department of Geographic Systems (KYGEONET 2009).

III. PROCEDURES

The erosion rates for each pond site were estimated by four methods:

- A simple weight estimate based on the product of average pond core density and pond sediment volumes.
- A distributed weight estimate based on a regression analysis of sediment density related to sediment depth.
- A distributed weight estimate based on a regression analysis of sediment density related to sediment depth with the unconsolidated pond sediment removed from calculations.
- A standard estimate based on the Revised Universal Soils Loss Equation v.2 (RUSLE2) sediment production model.

Several assumptions were made:

- 1) The erosion rate and transport rate to the pond has remained relatively constant, based on an inference that the vegetation cover has not changed over the time period that the sediment accumulated in the ponds.
- 2) Pond trapping efficiency is 100 percent.

- 3) The process of sediment consolidation in the ponds is consistent over all of the different sites.
- 4) All sediment found in a pond eventually would have been transported to the gully/channel network.

A. Site Selection, Location, and Typical Layout

Ponds that captured flow and sediment primarily from overland runoff were chosen. Several factors were considered in the selection of ponds for sampling. The factors included the following: location; geographic distribution within the watershed; accessibility; channel development upstream of pond; intensity of observed hillslope erosion; date of pond construction; pond size; pond outlet structures and sediment trapping efficiency; limited sediment deposition on hillslopes above the pond; and apparent uniform distribution of sediment in a pond.

Location: Pond sites were limited to those within the Benson Creek watershed and the Eden Shale Belt.

Geographic Distribution: The distribution of pond sites was kept as uniform as possible in order to limit any excessive influence of local variations which could result in a local sample bias. The relative location and size of each site drainage area within the Benson Creek watershed are shown in FIGURE 5.

Accessibility: Ponds had to be accessible by vehicle. A small boat and several pieces of equipment for conducting the bathymetric survey and soil sampling had to be transported

to the pond using a trailer. Choosing ponds that could be accessed by vehicle increased the number of samples that could be obtained in day-long sampling efforts.

Channel Development Upstream: To limit the collection of sediment eroded by concentrated flow in channel beds and banks, selected ponds were limited to those with minimal gulley and channel development upslope, as seen in FIGURE 6.

Intensity of Observed Hillslope Erosion: Ponds with a variety of hillslope erosion intensities were selected to represent varied land use/erosion. Drainage areas were ranked as having high, medium, or low erosive intensities by visual inspection of observed land cover and gullying. FIGURE 7 is a hillslope with a low erosional intensity. FIGURES 8 and 9 illustrate the results of increased erosional impact due to increasing amounts of livestock grazing.

Known Pond Construction Date: An accurate estimation of the time of sediment deposition is required for the determination of a time rate of sediment generation and deposition. Therefore, only ponds with known construction dates could be used. The dates of construction were determined from landowners.

Pond Size and Depth Limits: Sampling time and the length of sampling equipment limited the surface area and depth of the pond that could be sampled efficiently. Ponds were limited to depths of approximately 15 feet and surface areas under 2 acres.

Pond Outlet Structures and Sediment Trapping Efficiency: In order to relate the weight of sediment trapped by a pond to the sediment yield of the contributing hillslopes, an estimation of pond sediment trapping efficiency was required. Selected ponds were

small farm ponds designed to trap and retain as much runoff water possible. Typically, these types of ponds have dams with high crest elevation relative to the normal water surface and no water outlet such as a spillway. The selected ponds were required to have dams in good repair with no signs of dam spillover, allowing for a reasonable estimation of trapping efficiency of 100 percent (Verstraeten and Poesen 2001).

Limited Sediment Deposits on Hillslope above Pond: Soil particles eroded from hillslopes tend to deposit at breaks in slope. Therefore, ponds were selected based on limited hillslope sediment deposition; i.e. all sediment was transported into the pond. This lack of deposition at slope breaks was verified in the field before a site was accepted into the study, FIGURE 6.

Uniform Sediment Distribution: Selected ponds were limited to those with sediment that was undisturbed by exogenous forces after deposition resulting in a relatively uniform distribution of sediment density with depth.

The parameters of each site are tabulated in TABLE III. FIGURE 10 shows a typical site layout, with the boundaries of the site being defined by the local topography. Each site is a small watershed in its own right and is bound by ridgelines and the pond's dam. Illustrated by both orthographic and topographic details, the limits of the site are easily discernable.

FIGURES 11 and 12 illustrate different sediment depositional areas of a site. FIGURE 11 is a photograph of a pond looking upstream at the sediment fringe, from the dam. FIGURE 12 is a detail of the sediment fringe taken from just downstream.

Benson Creek Watershed with Site Locations

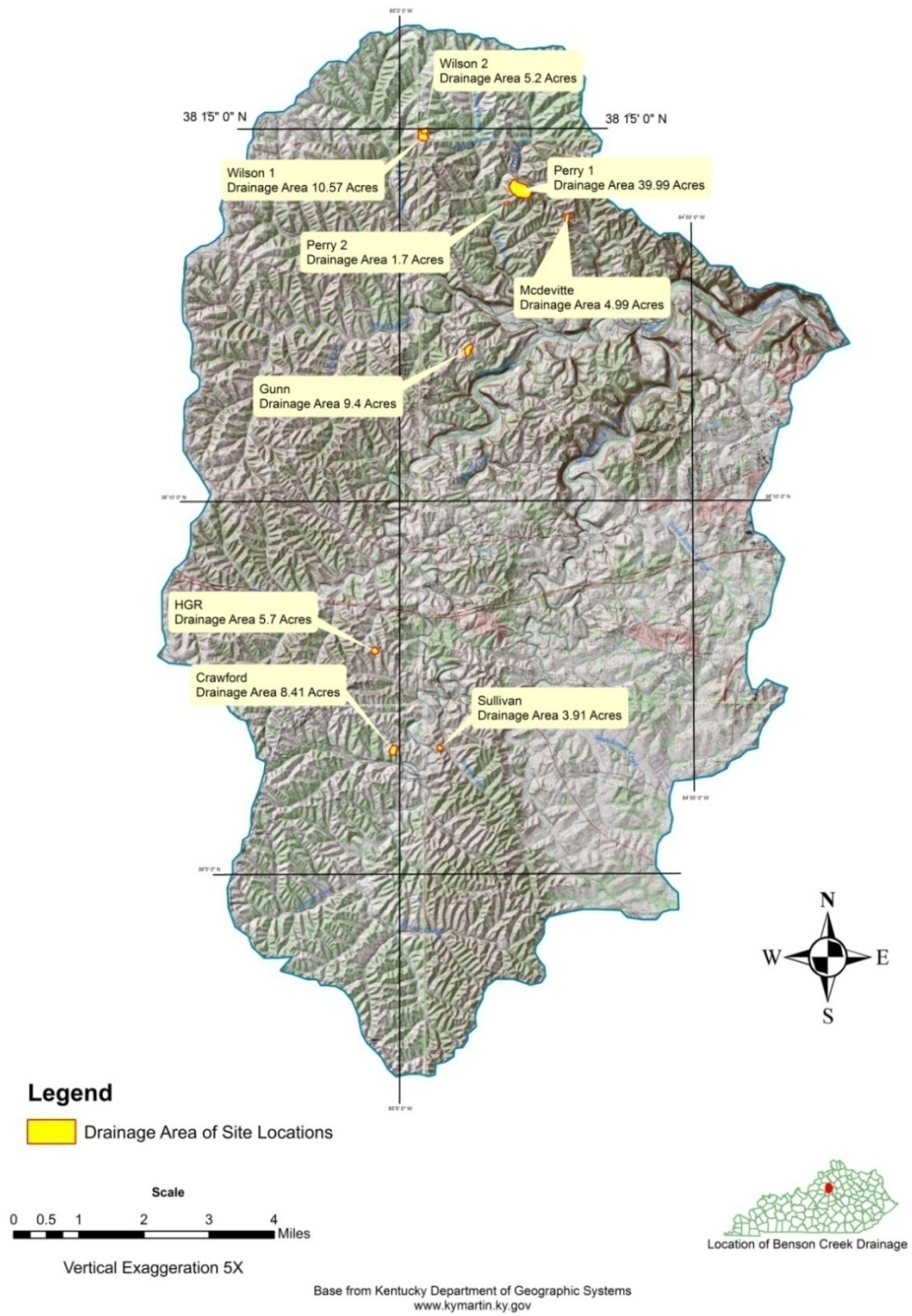

FIGURE 5 - Limits of the Benson Creek watershed, with site locations

TABLE III
SITE PARAMETERS

Pond Name	Drainage Area		Surface Area of Pond		Land Disturbance/Land usage
	ft ²	acres	ft ²	acres	
Hickory Grove	247,780	5.7	25,000	0.58	Med Intermittent Grazing
Crawford	365,815	8.41	27,500	0.63	Low Never Grazed
Gunn	408,533	9.4	19,881	0.46	Low Limited Grazing in past
McDevitte	216,794	4.99	16,286	0.37	Med Limited Grazing
Perry 1	1,738,735	39.99	77,712	1.79	Med Limited Grazing in past
Perry 2	72,400	1.67	1,564	0.04	Med Limited Grazing in past
Sullivan	170,000	3.91	11,000	0.25	High High Ammt of Grazing
Wilson 1	459,387	10.57	15,332	0.35	High Some Construction
Wilson 2	227,011	5.22	23,860	0.55	Low No grazing



FIGURE 6 - Looking up-stream of Crawford Pond illustrating lack of up-stream channel or gully development



FIGURE 7 - Mid-summer hillslope ground cover, low impact, Crawford Pond



FIGURE 8 - Mid-summer medium impact hillslope erosion, Hickory Grove Pond



FIGURE 9 - Mid-summer high impact hillslope erosion produced by overgrazing, Sullivan

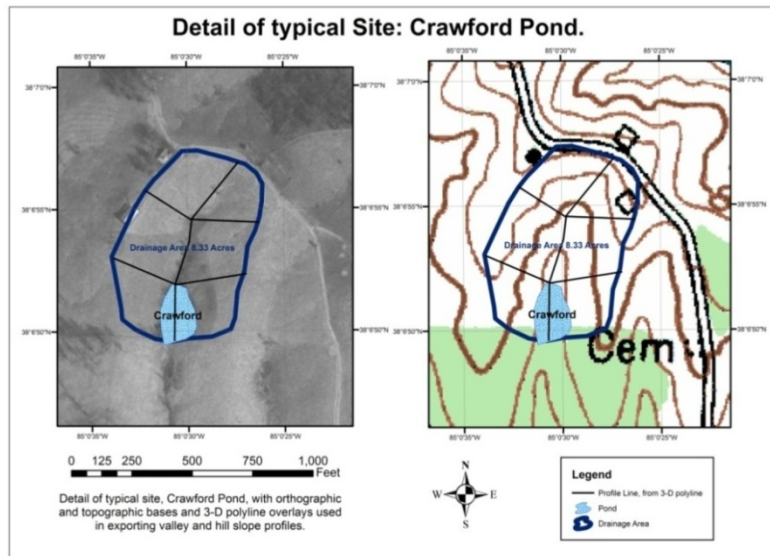

FIGURE 10 - Orthographic and topographic detail of typical site, Crawford Pond, illustrating pond location relative to hillslopes and top of drainage



FIGURE 11 - Looking upstream from dam at sediment fringe, Crawford Pond



FIGURE 12 - Crawford Pond sediment fringe, looking downstream towards dam

B. Site Surveys

Site surveys were conducted in mid-summer, locally the driest part of the year. This dry condition reduced pond water surfaces to their lowest seasonal levels, revealing two distinct depositional zones: the ponds and uncovered sediment fringes at the margins of the ponds. Each zone was surveyed to allow separate sediment volume calculations for both the ponds and the margins of the ponds. These volumes then were combined to determine erosion rates for the hillslopes above the ponds.

Two types of surveys—a land survey of surface features and a bathymetric survey of the impounded sediments—were conducted in accordance with methods outlined by the U.S. Bureau of Reclamation (Blanton 1982) to map each site accurately.

The land survey recorded the locations of major geomorphological features in the pond drainage area; the survey was done with a total station and data collector. Features including valley profiles and slopes, bathymetric cross-section endpoints, dam location, and location of any sediment fringes were located, measured and mapped. FIGURE 13 shows the results of the survey of a typical valley profile.

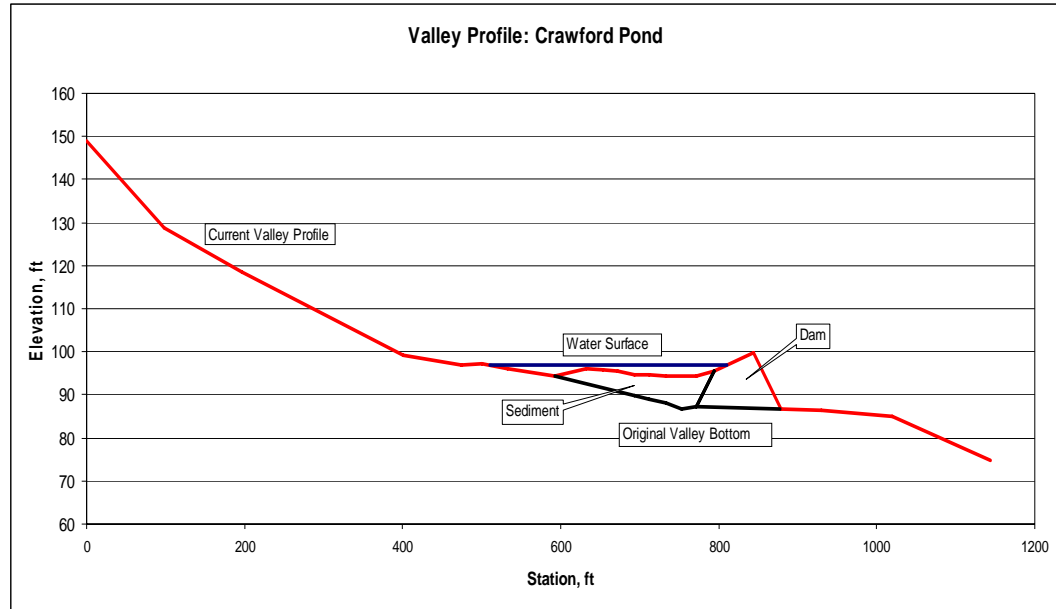

FIGURE 13 - Typical valley profile, Crawford Pond

The bathymetric survey consisted of a series of pond cross sections that created a survey grid over the submerged sediments. A steel tape was stretched across the pond along the cross sections and used as a guide for a small boat. Stationing, sediment depth measurements, and sampling were done from the boat. Grid spacing was determined in the field to best capture the site in a reasonable amount of time (see APPENDIX III for individual site survey layouts).

Water depth to the top of sediment was measured with a weighted tape. Sediment depth was determined by subtracting the water depth from the depth of a soil probe inserted into the sediment to the original pond bottom. The boundary between the pond bottom and the sediment material was indicated clearly by a distinct difference in penetration resistance easily felt with the probe. The difference in penetration resistance

was found to reflect a corresponding difference in density of material between sediments and pond bottom. These measurements then were used for sediment volumetric calculations. FIGURE 14 shows typical results of a bathymetric survey.

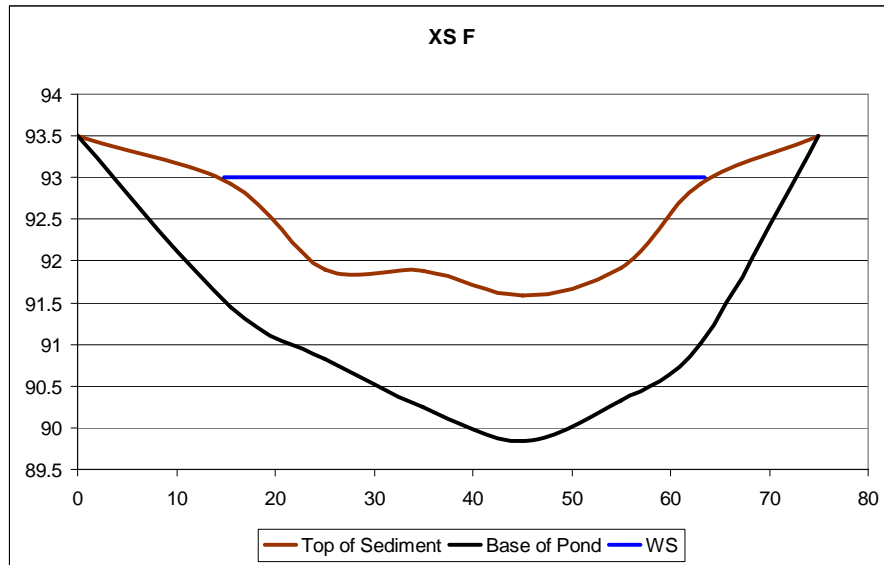

FIGURE 14 - Typical pond cross section with water surface (WS) and entrapped sediment

Measurement of sediment in the sediment fringes around the ponds was accomplished as part of the land survey. Points within the fringe were located with a total station and the depth of sediment at each point was measured with a soil probe. FIGURE 15 shows the pond outline, locations of probing and sampling, and cross-sections for a typical site—Crawford Pond—as well as a portion of the valley profile at that site. FIGURE 16 shows field personnel performing a bathymetric survey. FIGURE 17 shows a member of the research team determining pond and sediment depths.

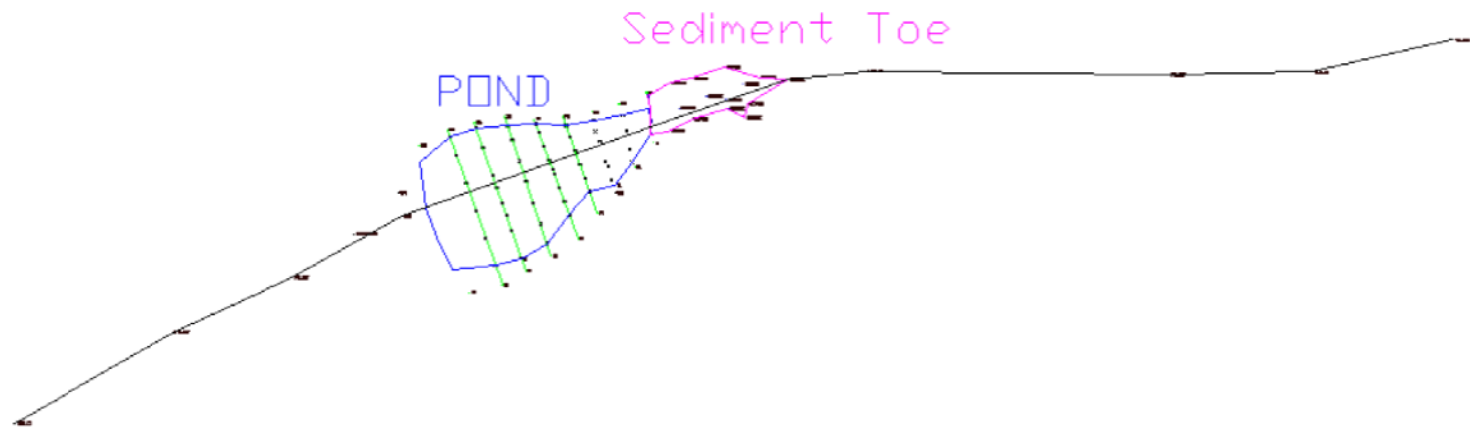

FIGURE 15 - Typical pond survey layout with cross sections, valley profile, pond outline, and sediment fringe, Crawford Pond

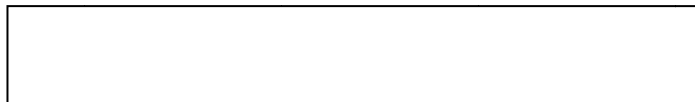



FIGURE 16 - Field personnel performing bathymetric survey



FIGURE 17 - Taking sediment depth measurements as part of the bathymetric survey, note steel tape used to position sediment probe

C. Coring

Submerged cores samples were taken with a modified Open Push Tube Sampler (ASCE 2000 McKean, 1986). The corer, shown in FIGURE 18, consisted of a sampling tube made out of a sharpened two-inch diameter PVC pipe six feet in length connected to a 1.5 inch-diameter couple connection equipped with a Schrader valve (allowing compressed air to be released into the corer).



FIGURE 18 - Close up detail of corer

The rest of the corer consisted of a ball valve connected to a hollow handle (.5 inch-diameter metal pipe) which allowed water to exit the corer upon its insertion into the sediment. The coring process consisted of inserting the corer through the pond sediments and into the original pond bottom for a couple of inches. *In situ* thicknesses of sediment

were measured while the corer was still in place, according to the bathymetric methods outlined previously. The ball valve then was closed, generating sufficient vacuum to allow retrieval of the core by carefully extracting the corer from the sediments. Then the core was pushed out of the corer with compressed air, into a cradle for transport and storage. All water collected during the coring process was retained in order to save any sediment put into suspension during the coring process.

Pond core sampling distribution was based on pond surface area and depth. Coring locations were selected to capture an accurate picture of sediment distribution, which was assumed uniform with depth. Each pond was evaluated in the field (see APPENDIX III for each individual pond coring pattern) and a representative coring plan was devised.

Sediment fringe cores were collected at locations deemed representative of the overall sediment conditions. Consideration of sediment thickness, apparent saturation level, and spatial distribution were used to determine core sampling location. Sediment fringe cores were collected by driving a sharpened, two inch-diameter PVC pipe through the sediment and into the underlying soils. The *in situ* length of the core was recorded and then the pipe was removed via a hole dug next to the core location, allowing complete removal of the sample. Then, the collection pipe was capped and used as a storage container. FIGURES 19 through 21 show typical coring operations. FIGURE 22 shows typical cores ready for transport to the laboratory for further testing and analysis.



FIGURE 19 - Taking a core, note operator standing on steel tape to position corer along cross section



FIGURE 20 - Operator extracts corer and prepares to transport it to shore



FIGURE 21 - Operator prepares to extract core into cradle; note bag to collect core water



FIGURE 22 - Cores collected at Hickory Grove Road, ready for transport

D. Pond Core Examination

Cores were air dried for several days in the laboratory to allow the sediment to dry and stiffen. Then, the cores were split longitudinally with a stiff thin taut wire to minimize the smearing of any internal structures. The split core was examined for internal structures that would allow determination of three important sediment zones: pre-depositional pond bottom soil, relatively consolidated pond sediment, and unconsolidated pond sediment.

Pre-depositional pond bottom soil: This soil was characterized by a dense yellow silt/clay layer sometimes containing small angular pieces of limestone gravel. This pre-depositional layer lacked any apparent organic material or internal layering.

Relatively consolidated pond sediment: This material consisted of grayish to yellow brown silt, and typically represented the majority of impounded hillside sediment. Internal layering was evident and attributed to seasonal depositional variation of sediment input, but the layering was not sufficiently consistent over different cores to allow differentiation of time of deposition (based on variable sediment input) to be made. The sediment also contained organic material consisting of plant debris, wood, grass, and leaves.

Unconsolidated pond sediment: This layer consisted of the same grayish to yellow brown silt as the consolidated sediment but lacked any layering or discernible internal structure. This layer represented the newest/youngest sediment to be transported

into the pond, and had not yet been consolidated. This sediment had an extremely low density consistent with a highly saturated soil structure.

To preserve any unconsolidated sediment disturbed by the coring process, all water collected by the corer was retained and decanted. The remaining slurry of pond water and core sediments was dried in the lab and the dried soil added to the unconsolidated sediments.

Sediment Fringe Core Analysis:

Cores from pond sediment fringes were composed of sediment similar in texture and color to the pond cores: yellow brown silt with organic plant debris. No internal structuring was evident--however, a clear distinction between sediment and the valley floor could be made, based on color and texture. FIGURE 23 shows a typical core that allowed differentiation of sampled sediment and soil into the three zones mentioned previously.



FIGURE 23 - Photo of split pond core exhibiting the three sediment zones and internal structures

Core Sample Bulk Densities

Bulk densities for the pond sediments were calculated from the pond cores according to a method described by Brady (1984):

$$\rho_{BC} = \frac{M_{CS}}{V_C} \quad (1)$$

Where ρ_{BC} = the Bulk Density of a core (lbs/ft³),

M_{CS} = the oven dried weight of core sediment (lbs),

and V_C is the *in situ* volume of the core sediment (ft³).

The oven-dried weight of sediment was determined from the samples dried at 110° C for 24 hours. The volumes were calculated from the product of the pond situ lengths (taken from the soil probe measurements) and the internal cross-sectional area of the corer (in this case, the corer internal diameter was 2 inches, so the area was 0.022ft².)

Sediment Fringe Sample Bulk Densities

Bulk densities for the sediment fringe samples were calculated in a manner similar to the method used for the pond sediments:

$$\rho_{ST} = \frac{M_{STC}}{V_{STC}} \quad (2)$$

Where ρ_{ST} = the Bulk Density of the sediment fringe core (lbs/ft³),

M_{STC} = the oven dried weight of sediment fringe core sediment (lbs),

and V_{STC} is the *in situ* volume of the sediment fringe core sediment (ft³).

The oven-dried weights of sediment were determined from the samples dried at 110° C for 24 hours. The volumes were calculated from the product of the sediment fringe *in situ* thicknesses (taken from the soil probe measurements) and the cross-sectional area of the corer. TABLE IV shows the results of calculations of bulk density as defined previously, for all the study sites. The data have been sorted by thickness of sediment (or length of sediment core) to facilitate additional analysis in which the variation in bulk density with core length was examined.

TABLE IV

BULK DENSITY OF CORES, SORTED BY INCREASING LENGTH FOR ALL PONDS (see APPENDIX I for additional detail)

Core	Length Ft	Density Lbs/ft ³
P1 K-60	0.47	55.28
P1 N1-M2	0.70	48.17
P1 G-36	0.86	33.55
M C-60	1.12	32.20
G F-40	1.15	37.76
P1 G-66	1.17	33.96
W2 2	1.22	25.20
P1 B1-A2	1.30	24.88
M G-23	1.34	33.53
W2 3	1.50	24.96
M I-17	1.59	32.69
C F-35	1.63	15.35
S 4	1.65	35.38
C Head	1.67	14.13
P2 B-46	1.88	43.25
S 2	1.99	46.50
C C-40	2.03	18.48
C C-60	2.06	17.17
P1 D-81	2.06	34.84
M E-34	2.08	24.90
C E-50	2.20	12.41
G F-90	2.21	35.18
P2 D-30	2.32	14.37
G B-60	2.34	27.23
HG 5	2.36	27.74

Core	Length Ft	Density Lbs/ft ³
P1 D-51	2.40	16.22
HG 3	2.42	23.13
C Dam	2.47	18.98
HG 10	2.48	22.50
HG 1	2.55	17.33
P1 K-40	2.61	10.57
M A-80	2.63	9.17
HG 4	2.83	20.49
HG 6	2.99	14.26
HG 8	3.10	36.47
W1 F-34	3.14	37.60
HG 2	3.15	13.27
S 1	3.20	35.73
HG 11	3.28	28.53
G C-70	3.29	39.23
S 3	3.35	27.86
P2 C-30	3.56	10.26
G D-70	3.60	38.14
M A-45	3.65	12.74
W1 H-40	3.93	30.21
HG 9	4.77	16.97
W1 F-54	5.17	19.34
W1 B-40	5.64	20.07
W1 D-32	6.11	21.79
W1 D-51	6.16	18.04

E. Volume of Pond Sediments

The volume of sediment trapped by each pond was estimated from the bathymetric survey measurements. Soil probe measurements were used to obtain elevations for both the top of the sediment layer and the original pond bottom. From

these elevation points, separate TINs (Triangular Irregular Network) location points were generated for each surface. Using the Autodesk Land Desktop Terrain Editor, volumetric calculations for the layers defined between the TIN points were calculated, resulting in an estimate of total impounded sediment.

The volume of sediment contained in the sediment fringes was calculated using the same method as used for the pond sediments. TINs were generated for both the top of the sediment layer and the original sub-sediment surface. The Autodesk Land Desktop Terrain Editor was used for volume calculations defined between the different TIN layers. FIGURE 24 shows a representative set of data used to calculate sediment volume.

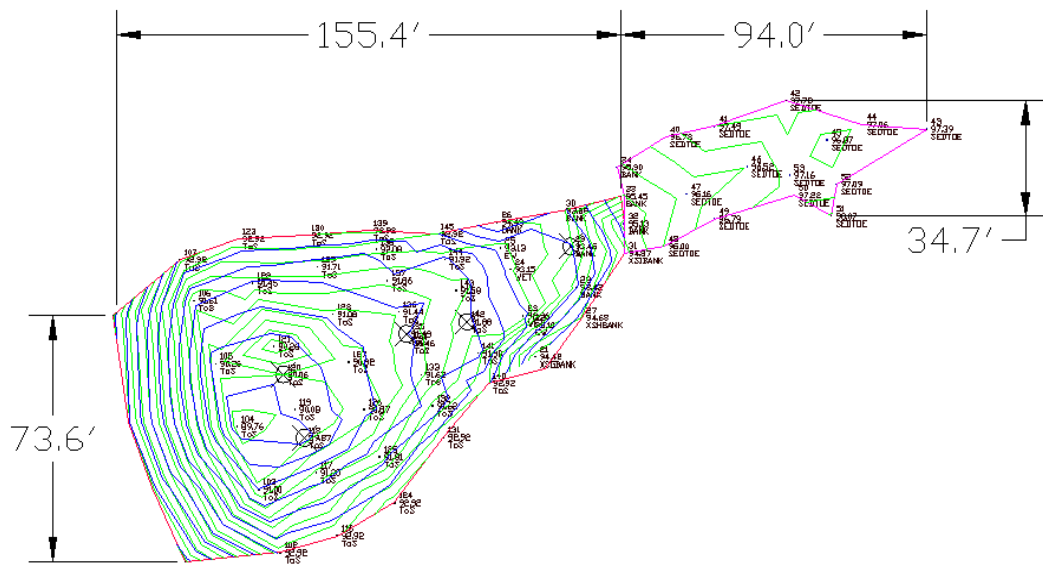

FIGURE 24 - Land Desktop Terrain Editor surfaces used to calculate volume of entrapped sediment; green contours represent the original valley floor and blue contours represent the top of the sediment contained in the pond

F. Estimated Weight of Pond Sediment

1. Average Bulk Density

In order to calculate the amount of sediment eroded from the hillslopes, the volume of sediment must be converted to weight of sediment. This calculation was done by applying the bulk densities of the cores to the volumes of sediment.

The weight of sediment entrapped by a particular pond was estimated as:

$$M_{PS} = (\overline{\rho_{BC}} \times V_P) + (\rho_{ST} \times V_{ST}) \quad (3)$$

Where M_{PS} = the estimated total weight of entrapped sediment (tons),

$\overline{\rho_{BC}}$ is the average bulk density of that particular pond's cores (lbs/ft³),

V_P is the volume of particular pond sediment (ft³),

ρ_{ST} is the bulk density of the sediment core for the pond sediment fringe(s) (lbs/ft³),

and V_{ST} is the volume of sediment fringe sediment(ft³).

2. Distributed Bulk Density

To improve the estimate of local bulk density and the derived sediment weight, a relation was developed to predict bulk density from the depth of sediment measured. The relation was developed using the bulk density measurements of the core samples and their associated *in situ* thickness values (equivalent to the sediment depth at the core).

This step was taken to limit any bias introduced by differences between the sampling distribution and the sediment distribution (as shown by thickness).

Although the collection of the pond cores was done in a manner to minimize any sampling bias, the total volume of sampled sediments was considerably smaller than the overall sediment volume. Variance between the distribution of sampling sites and the sediment distribution could introduce a bias that would reduce the estimated sediment volume accuracy. Therefore, the developed relationship between bulk density and sample length was applied to all sediment depth (core length) measurements.

In this way, a larger number of calculated sediment densities were available to estimate the weight of sediment in the pond. Additionally, the larger number of density values were distributed over a larger area of the sediment layer. This increase in density values with their wider distribution reduces the discrepancy between sediment distribution and sampling distribution. The correlations also tend to minimize the effects of any erroneous density calculations by using a larger number of cores to estimate densities.

Bulk density of saturated silt and clay soils calculated from samples is dependent on degree of consolidation, if the volume of the sampled soil mass is in process of decreasing in response to gravitational pull or external pressure. The consolidation of fine-grained sediments is governed by several site-specific parameters such as soil stiffness and hydraulic conductivity, degree of saturation, stress history, and time (Holtz and Kovacs 1981). As this study was focused on a limited geographical area with sediment of similar origins and depositional environments, the soil properties were

assumed to be similar. In addition, the sediments were assumed to be constantly submerged, undisturbed, and in their original depositional state (no prior loading), the degree of saturation was taken to be 100 percent and the sediments were considered to be normally consolidated. As such, a gross correlation between the bulk density and the *in situ* depth of sediment was expected. The depth of the sediment was a gross indicator of the load on the sediment causing consolidation. Many unmeasured factors, however, related to consolidation could weaken the correlation. These unquantified factors include an unknown period of loading, the variation of soil stiffness and hydraulic conductivity, and non-uniform erosion rates between sites.

Royal (2003) demonstrated that density within a core increases with depth. This increase in density appears to be due to increased loading and the resultant consolidation of the sediment. Therefore, correlation equations between bulk density and *in situ* length of sediment sample were developed using least squares linear regression. The correlation was described by a power function as:

$$R = a L^b \quad (4)$$

Where a and b are coefficients of the power function. The correlation between bulk density and *in situ* length of sediment sample for all pond samples is given by:

$$\mathbf{Bulk\ Density = 29.2 \times Length^{-0.214}} \quad (5)$$

FIGURE 25 shows the plot of bulk density versus sediment core length. The accuracy of the relationship is described by a standard regression analysis and confidence interval plot. The R^2 value for the fit of the graph was 0.7619 and a standard error of 40.7

percent was determined from the transformation from the log 10 domain as a percentage of the mean according to Tasker (1978).

This correlation relationship was applied to all sediment depth measurements from the bathymetric survey in each pond to calculate new densities for each sediment depth measurement. These new density values were averaged for each pond, resulting in new pond bulk density values. These bulk density values were multiplied by the previously calculated pond sediment volumes resulting in new total weights of entrapped pond sediment in tons.

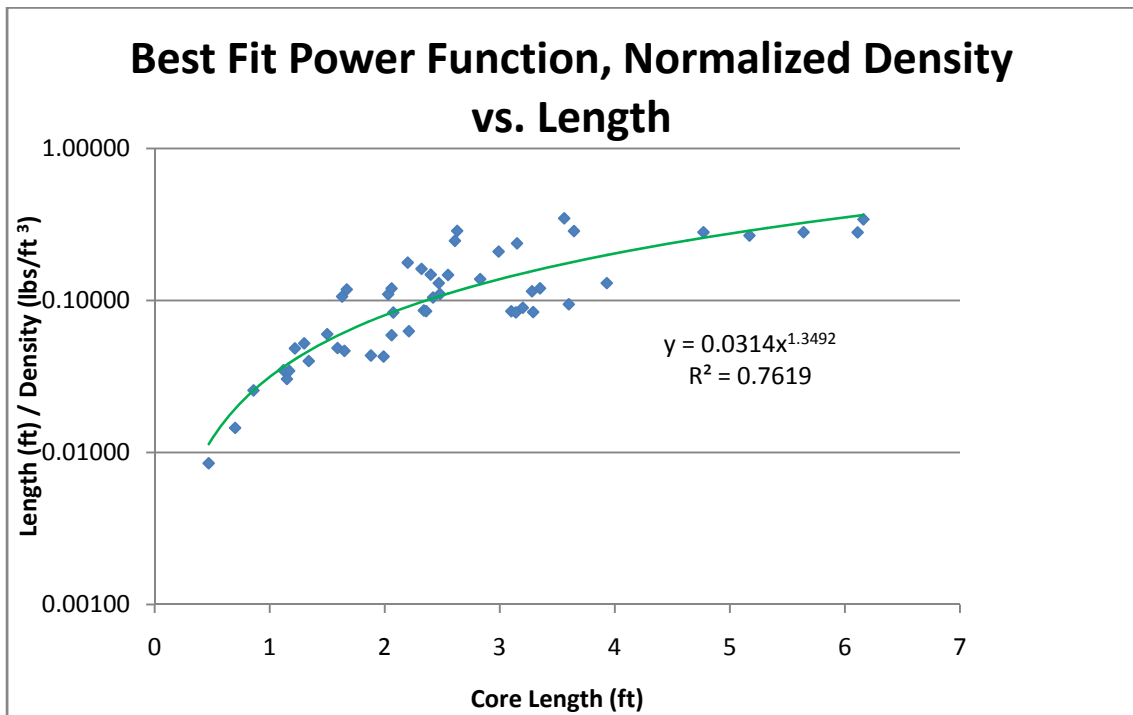

FIGURE 25 - Plot of core density normalized to length showing power relationship of length to density versus core length

3. Distributed Bulk Density Minus Unconsolidated Material

Pond sediment densities varied considerably between the unconsolidated material at the tops of the sediment cores and the consolidated sediment. The unconsolidated material is derived from the most recent erosional events and occupies a large low-density percentage of the total pond sediment volume. This distribution of the unconsolidated material can create a potential bias towards recent events in pond sediment weight calculations. Therefore, the removal of the unconsolidated material from sediment weight calculations should better represent the distribution of sediment weight and remove any bias introduced by recent sedimentation events.

Bulk densities and sediment volumes for each pond were recalculated after the removal of the unconsolidated layer from sediment depth measurements. Removal of the unconsolidated material for calculations was accomplished easily with the core samples because the boundary between the unconsolidated layer and the consolidated sediment zone was distinct. However, determining the amount of unconsolidated material from sediment depth measurements was more difficult.

In situ sediment depth measurements made with either a weighted tape or a soil probe accurately recorded the boundary elevations of the water and the unconsolidated material or between the sediment and the pond bottom because of the extreme density differences between the water and any sediments, and between the sediments and the pond bottom soil. However, the determination of the unconsolidated sediment-consolidated sediment boundary was impossible with the available tools. Therefore, a reduction factor was calculated from each core and applied to the sediment depth

measurements to remove the unconsolidated material from consideration in sediment weight estimates. This core reduction factor consisted of the length of consolidated sediment as measured from the split cores divided by the *in situ* sediment depth as measured in the pond. This percent reduction was averaged across each pond and applied to each sediment depth measurement, resulting in an estimated sediment depth measurement without the “fluffy” top unconsolidated sediment (FIGURE 26). These new sediment depths then were used to generate new sediment TIN surfaces. Consolidated sediment volume was calculated from the TINs using Land Desktop 2007 as described above.

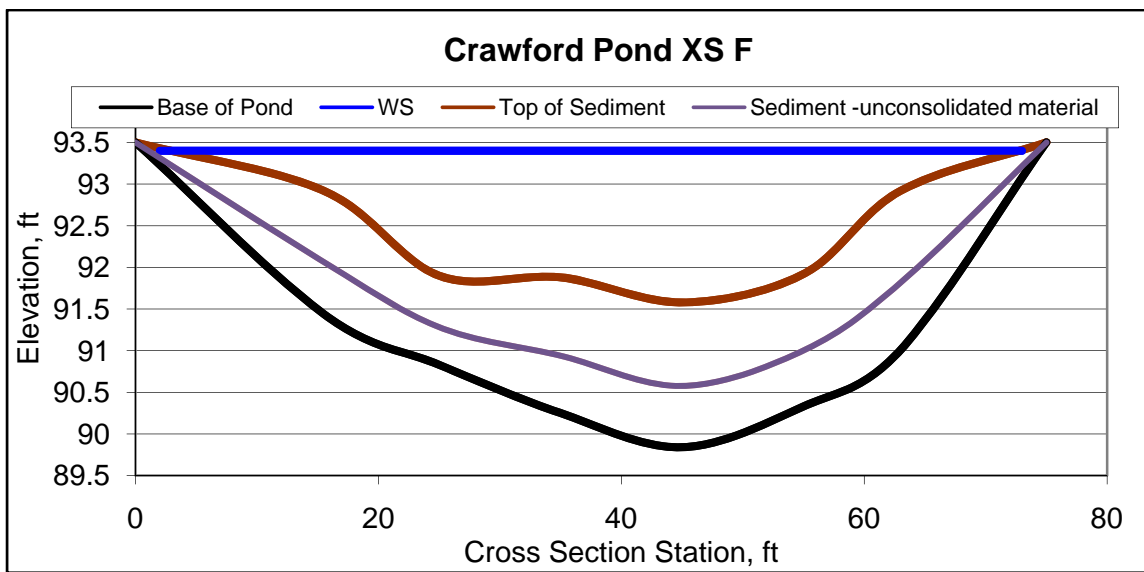

FIGURE 26 - Typical cross section with different sediment layers

Several assumptions were made in the calculation of the length reduction factor and new sediment volumes:

- Sediment was assumed to enter the pond as unconsolidated material.

- The sediment material consolidated at a constant rate per load increase (depth of sediment column) throughout the pond resulting in similar percentages of consolidated material versus unconsolidated material throughout the pond.
- The consolidated sediment core zone experienced little compression in the coring process and, further, minimal shrinkage of this layer occurred in the lab. This assumption is supported by the minimal distortion of sediment layers at the outside margins of the samples where the pull of the inner surface of the corer was greatest.

As with the distributed bulk density method described above, a correlation equation was developed for the samples from which length of unconsolidated sediment was subtracted. The correlation between bulk density and *in situ* length of sediment sample was developed using least squares linear regression. The correlation was described by a power function as:

$$R = a L^b \quad (6)$$

where a and b are coefficient and exponent of the power function. The correlation between bulk density and *in situ* length of sediment sample for all pond samples from which unconsolidated sediment length was subtracted is given by:

$$\mathbf{Bulk\ Density = 46.1 \times Length^{-0.204}} \quad (7)$$

The accuracy of the relationship is described by a standard regression analysis and confidence interval plot. The R^2 value for the fit of the graph was 0.8624 and a standard error of 30.6 percent was determined from the transformation from the log 10 domain as

a percentage of the mean according to Tasker (1978). FIGURE 27 shows the results of the correlation regression analysis.

The bulk density to length relationship for the samples without unconsolidated sediment was applied to all sediment depth measurements from the bathymetric survey in each pond to calculate new densities for each sediment depth measurement. These new density values were averaged for each pond resulting in new pond bulk density values. The bulk density values were multiplied by the pond sediment volumes obtained after unconsolidated sediment lengths were subtracted from core lengths, resulting in a new calculation of weight of sediment (minus unconsolidated material) entrapped in each pond, in tons.

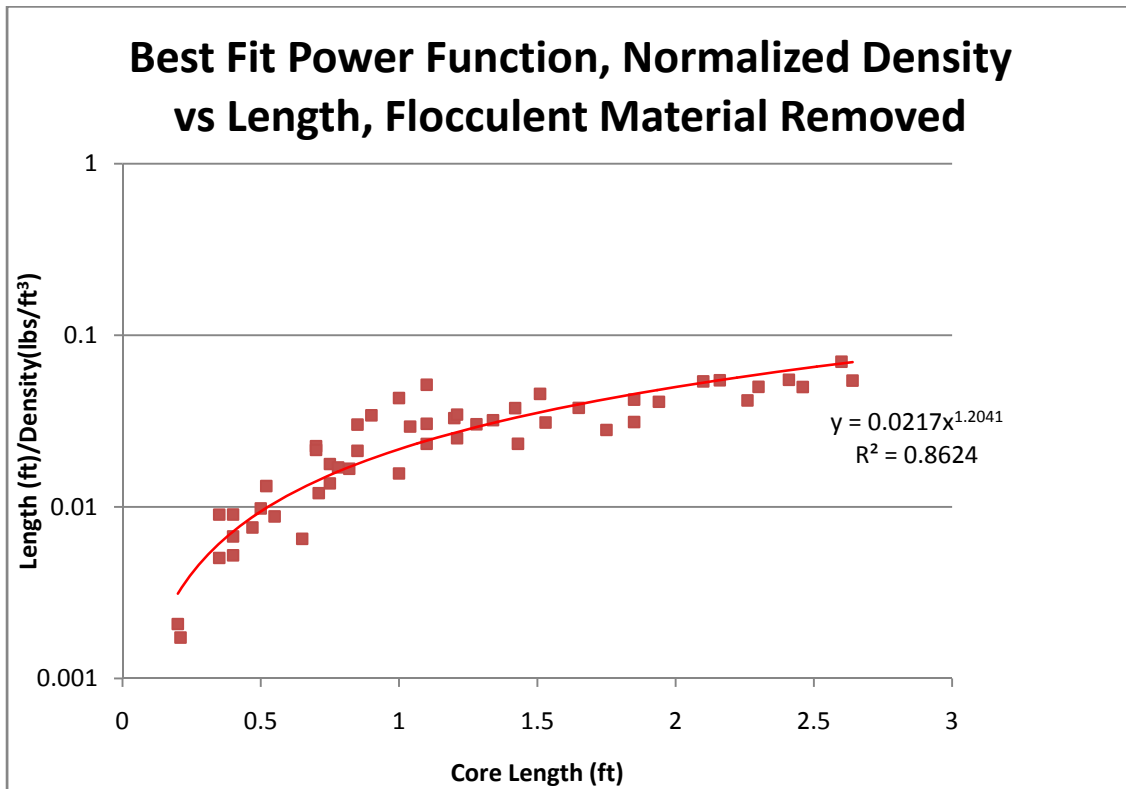

FIGURE 27 – Correlation between length/density ratio and core length, for samples without unconsolidated sediment

G. Average Sediment Deposition Rate

In order to estimate hillslope sediment yield, the weight of the sediment trapped in a pond must be converted to an apparent rate of sediment deposition.

The average rate of sediment deposition was estimated as:

$$S = \frac{\left(\frac{M_{PS}}{DA}\right)}{T} \quad (8)$$

S = Sediment deposition rate or sediment yield from hillslopes (tons/acre/year),

M_{PS} = Weight of pond sediments (tons, includes both pond and sediment fringe sediments),

DA = drainage area contributing to pond (acres),

T = age of pond (years).

Frequencies of sediment yield occurrences for the various methods are plotted in FIGURE 28. The calculation of the sediment yield takes into account differences in drainage areas and the period of sediment accumulation. Accordingly, differences in the estimated yield rates are therefore attributed to hillslope steepness, land use, and local variation.

As part of this study the calculated sediment yields then were compared to results from a Revised Universal Soil Loss Equation v.2 (RUSLE2) model. The RUSLE2 model was set up to approximate the local conditions as closely as possible.

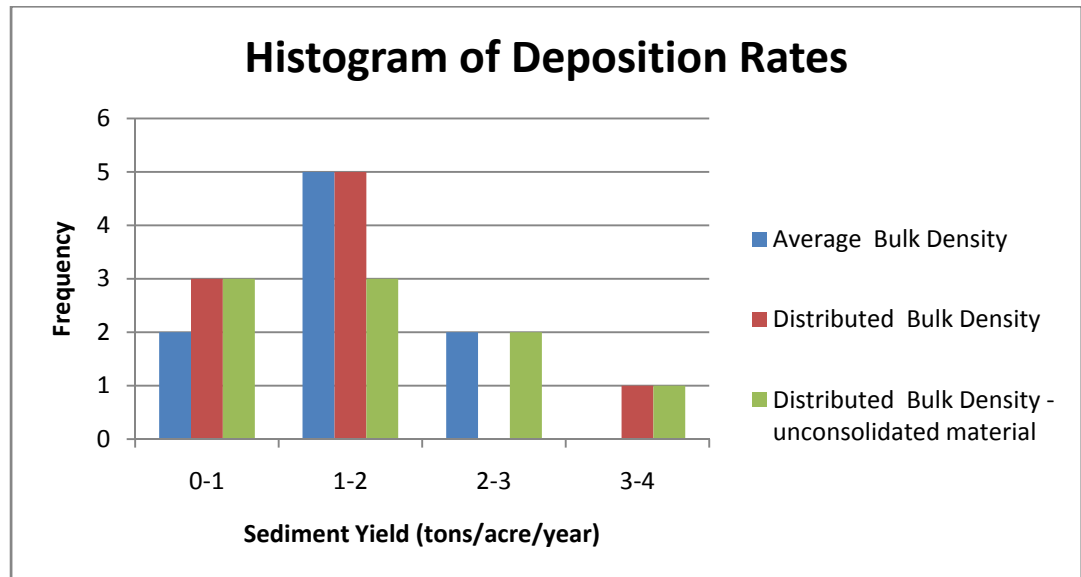

FIGURE 28 - Frequency of depositional rates

H. RUSLE2 Study

In 1965, the Universal Soil Loss Equation (USLE) was developed to estimate upland soil erosion for conservation planning. Based on thousands of field measurements and data from test plots, USLE predicted soil loss from sheet or rill erosion from a roughly planar hillslope area (Wischmeier and Smith 1978). USLE was intended primarily to allow land-use planners to estimate soil erosion rates from a wide variety of upland slopes, precipitation values, soil types, vegetative covers, and land-use practices. Revised in 1997 (RUSLE), and again in 2002 (RUSLE2), new versions applied local climatic data, soil information, and more detailed crop cover management strategies to a Windows-based program (USDA-ARS 2005).

It is common practice among land-use planners to use RUSLE for estimating upper hillslope erosion and subsequent sediment input into stream headwaters for regional systems (Bureau of Reclamation 2006 and ASCE 2008). The use of RUSLE2 on such large, complex regional systems necessitates simplification of the field data, utilizing representative values for several of the variables in the RUSLE2 equation in the interests of expediency (cost and time). This simplification of environmental features in the estimation of soil loss and transport can have an adverse effect on the predictive accuracy of the model. Using RUSLE2 without field correlation is at best an unreliable estimation. As part of this study, field determined hillslope erosion rates were compared with RUSLE2 results for each of the pond sites.

RUSLE2 uses the following equation to predict the soil erosion (ASCE 2008):

$$A = R \cdot K \cdot L \cdot S \cdot C \cdot P \quad (9)$$

Where **A** is the soil loss per unit area (erosion),

R = rainfall-runoff erosivity factor,

K = soil erodibility factor,

L = slope length factor,

S = slope steepness factor,

C = cover-management factor,

P = support practice factor.

The variables R and K are functions of climatic-soil interactions; C and P are factors related to land use; and L and S are based on the topographic nature of a site. R is easily determined by selecting the correct soil types from the NRCS web soil survey (NRCS 2008). K is calculated from local climatic data imported into the model.

C and P can be estimated from land use and crop rotations; however small local variability has been shown to alter RUSLE results (Danby 2006) by as much as a factor of 10. Land use practices were entered into the crop management tool with differences in land cover and degree of grazing being the most important factors.

The factors L and S are somewhat more problematic. In order to be able to apply RUSLE2 to a large watershed, the complex slope nature of a headwater valley has to be simplified. In this study, site elevation data were collected from 30-foot USGS Digital Electronic Models and processed with ArcMap GIS software. The location of representative slope and length factors was taken at a point two-thirds of the distance from the dam to the most upstream point in the drainage. The factors then were calculated from the numerical average of both the right and left bank slope values and lengths. Although somewhat arbitrary, this two-thirds distance appears to be a good compromise between steeper upstream slope lengths and longer downstream slope lengths. More investigative work is needed to better determine correct representative parameters for the S and L factors, but such work was beyond the scope of this study.

Measurements at the Crawford Pond location illustrate the procedure adopted. The valley distance between the dam and the highest upstream point is 812 feet. Two-thirds of the way upstream from the dam is 541 feet. At this point, both right and left

valley profiles were generated and their slopes and lengths were averaged to obtain representative S and L factors. Table V gives information obtained at each site for use in the RUSLE2 model. FIGURE 29 shows where slopes were obtained, and FIGURE 30 shows typical results of slope characterization. The input values obtained for each pond were used in the RUSLE2 model to predict erosion and consequent deposition of sediments in each of the ponds at the sites considered in this study, as described in the next chapter.

TABLE IV
SITE SUMMARY INFORMATION FOR RUSLE2 MODEL

Pond Site	Drainage Area acres	Land Disturbance	Length ft	Slope %	Soil	RUSLE2 Erosion Rate tons/acre/year
Crawford	8.41	Low, Harvest hay/grass	240.00	15.00	FdD	0.94
Gunn	9.40	Low, Rotational grazing	252.00	13.00	FdD	0.81
Hickory Grove	5.70	Medium, Rotational grazing	211.00	19.00	EfE	5.50
McDevitte	4.99	Medium, Rotational grazing	144.00	15.00	EfE	4.30
Perry 1	39.99	Medium, Rotational grazing	533.00	12.00	EfE	4.30
Perry 2	1.67	Medium, Rotational grazing	147.00	18.00	EfE	2.90
Sullivan	3.91	High, Continuous overgraze	202.00	12.00	EfE	2.40
Wilson 1	10.57	High, Some construction	253.00	19.00	EfE	3.64
Wilson 2	5.22	Low, Permanent cover not harvested	501.00	12.00	EfE	0.48

**Crawford Pond Detail:
Hill Slope and Length for RUSLE2**

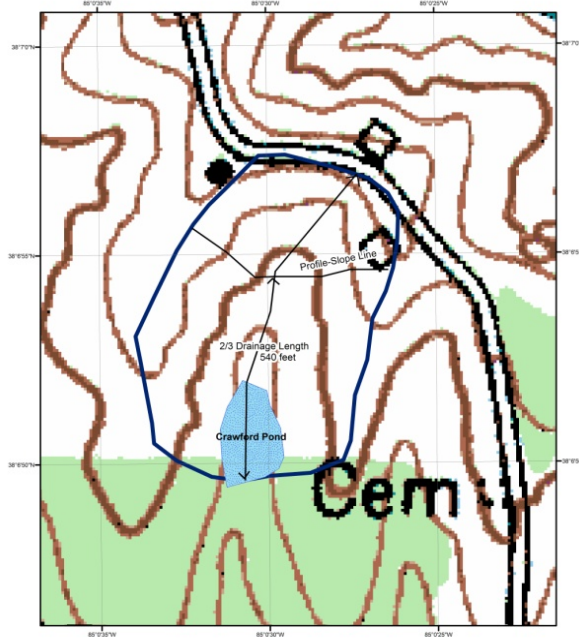

FIGURE 29 - Location of representative slope profiles

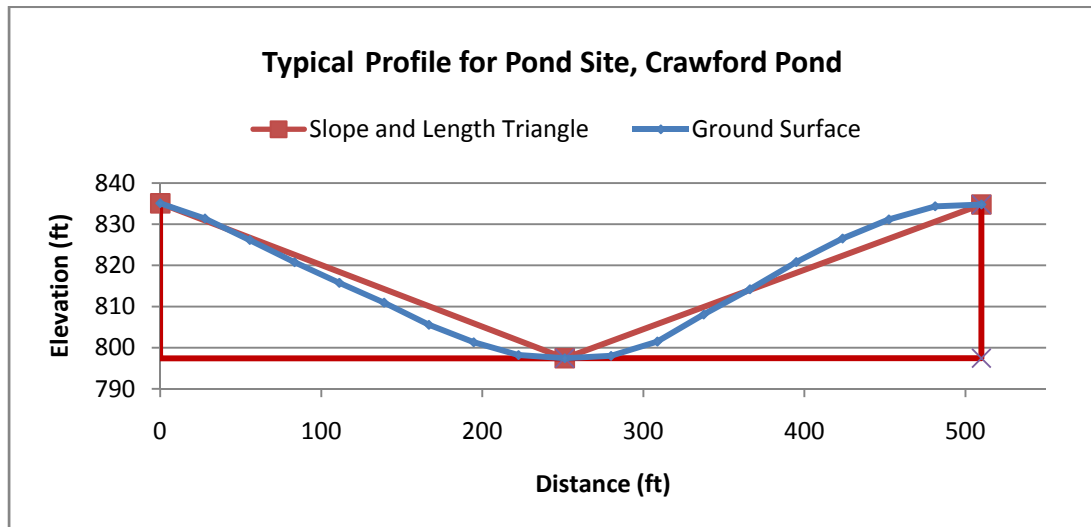

FIGURE 30 - Valley cross section with representative slopes and lengths

IV. RESULTS

The results of split pond core examinations are summarized in TABLE VI a,b. The length as measured in the laboratory (ft), the calculated density (lbs/ ft³), and the ratio of length to density for both total core sediments and for sediments with the unconsolidated material removed are listed. The difference in length and the percentage of length reduction are also listed to show the effects of removing the unconsolidated material from the estimate. These length reductions in the measured cores were used in the calculations of volume (with reduction for the removal of the unconsolidated material).

As described previously, the total volume of submerged pond sediments (ft³) was estimated from a bathymetric survey. A reduction factor calculated from ratios of unconsolidated material to consolidated material in the pond cores was used to determine a reduced sediment volume for analysis without the unconsolidated material, as shown in TABLE VII. Sediment fringe sediment volumes were calculated from soil probe data. Final sediment volumes are listed in TABLE VIII.

TABLE VI (a)

SPLIT CORE RESULTS AND LENGTH REDUCTION BETWEEN TOTAL CORE SEDIMENT AND SEDIMENT MINUS
UNCONSOLIDATED MATERIAL

All Pond Cores				-Flock					
Core	Length	Density	l/d	Core	Length	Density	l/d	Δ Length	%
C C-40	2.03	18.4755	0.10988	C C-40	0.78	45.91	0.01699	1.25	0.615764
C C-60	2.06	17.1669	0.12000	C C-60	0.75	42.2	0.017773	1.31	0.635922
C Dam	2.47	18.98095	0.13013	C Dam	1.2	36.46	0.032913	1.27	0.51417
C E-50	2.2	12.40688	0.17732	C E-50	1	23.2	0.043103	1.2	0.545455
C F-35	1.63	15.34844	0.10620	C F-35	0.7	31.01	0.022573	0.93	0.570552
C Head	1.67	14.13291	0.11816	C Head	0.7	32.6	0.021472	0.97	0.580838
G B-60	2.34	27.23448	0.08592	G B-60	1.34	41.85	0.032019	1	0.42735
G C-70	3.29	39.22822	0.08387	G C-70	2.26	54.14	0.041744	1.03	0.31307
G D-70	3.6	38.13687	0.09440	G D-70	2.64	48.5	0.054433	0.96	0.266667
G F-40	1.15	37.75842	0.03046	G F-40	0.85	40.06	0.021218	0.3	0.26087
G F-90	2.21	35.18467	0.06281	G F-90	1.65	43.7	0.037757	0.56	0.253394
HG 1	2.55	17.33399	0.14711	HG 1	0.71	59.04	0.012026	1.84	0.721569
HG 10	2.48	22.50499	0.11020	HG 10	1.1	47.21	0.0233	1.38	0.556452
HG 11	3.28	28.53357	0.11495	HG 11	1.43	61.34	0.023313	1.85	0.564024
HG 2	3.15	13.2656	0.23746	HG 2	1.1	36.06	0.030505	2.05	0.650794
HG 3	2.42	23.12697	0.10464	HG 3	1.28	42.24	0.030303	1.14	0.471074
HG 4	2.83	20.48822	0.13813	HG 4	1.42	37.7	0.037666	1.41	0.498233
HG 5	2.36	27.74357	0.08506	HG 5	1.21	48.18	0.025114	1.15	0.487288
HG 6	2.99	14.26032	0.20967	HG 6	1.04	35.4	0.029379	1.95	0.652174
HG 8	3.1	36.46912	0.08500	HG 8	1.75	62.3	0.02809	1.35	0.435484
HG 9	4.77	16.97358	0.28103	HG 9	1.53	49.28	0.031047	3.24	0.679245
M A-45	3.645	12.73904	0.28613	M A-45	0.82	49.11	0.016697	2.825	0.775034
M A-80	2.63	9.168333	0.28686	M A-80	0.52	39.28	0.013238	2.11	0.802281
M C-60	1.12	32.19878	0.03478	M C-60	0.85	28.17	0.030174	0.27	0.241071
M E-34	2.075	24.89525	0.08335	M E-34	1.21	35.07	0.034502	0.865	0.416867
M G-23	1.34	33.53403	0.03996	M G-23	0.47	61.9	0.007593	0.87	0.649254
M I-17	1.59	32.69362	0.04863	M I-17	0.75	54.7	0.013711	0.84	0.528302

TABLE VI (b)

SPLIT CORE RESULTS AND LENGTH REDUCTION BETWEEN TOTAL CORE SEDIMENT AND SEDIMENT MINUS
UNCONSOLIDATED MATERIAL

All Pond Cores				-Flock				Δ Length	%
Core	Length	Density	l/d	Core	Length	Density	l/d		
P1 B1-A2	1.3	24.87747	0.05226	P1 B1-A2	0.5	51	0.009804	0.8	0.615385
P1 D-51	2.4	16.22455	0.14792	P1 D-51	0.55	62.49	0.008801	1.85	0.770833
P1 D-81	2.06	34.83746	0.05913	P1 D-81	1	63.84	0.015664	1.06	0.514563
P1 G-36	0.86	33.55215	0.02563	P1 G-36	0.4	59.44	0.006729	0.46	0.534884
P1 G-66	1.17	33.96468	0.03445	P1 G-66	0.4	76.61	0.005221	0.77	0.65812
P1 K-40	2.61	10.57486	0.24681	P1 K-40	0.2	96.29	0.002077	2.41	0.923372
P1 K-60	0.47	55.27913	0.00850	P1 K-60	0.35	38.8	0.009021	0.12	0.255319
P1 N1-M2	0.7	48.16683	0.01453	P1 N1-M2	0.4	44.28	0.009033	0.3	0.428571
P2 B-46	1.88	43.24723	0.04347	P2 B-46	0.65	99.72	0.006518	1.23	0.654255
P2 C-30	3.56	10.25705	0.34708	P2 C-30	1.1	21.37	0.051474	2.46	0.691011
P2 D-30	2.32	14.37444	0.16140	P2 D-30	0.9	26.33	0.034182	1.42	0.612069
S 1	3.2	35.73349	0.08955	S 1	2.41	43.79	0.055035	0.79	0.246875
S 2	1.99	46.49731	0.04280	S 2	1.85	43.84	0.042199	0.14	0.070352
S 3	3.35	27.86414	0.12023	S 3	2.16	39.47	0.054725	1.19	0.355224
S 4	1.65	35.37612	0.04664	S 4	1.51	33.16	0.045537	0.14	0.084848
W1 B-40	5.64	20.06541	0.28108	W1 B-40	2.3	45.9	0.050109	3.34	0.592199
W1 D-32	6.11	21.78601	0.28046	W1 D-32	2.46	49.2	0.05	3.65	0.597381
W1 D-51	6.16	18.03565	0.34155	W1 D-51	1.94	47.36	0.040963	4.22	0.685065
W1 F-34	3.14	37.60175	0.08351	W1 F-34	1.85	59.2	0.03125	1.29	0.410828
W1 F-54	5.17	19.33935	0.26733	W1 F-54	2.1	38.97	0.053888	3.07	0.59381
W1 H-40	3.93	30.20614	0.13011	W1 H-40	2.6	37.05	0.070175	1.33	0.338422
W2 2	1.22	25.19744	0.04842	W2 2	0.35	69.4	0.005043	0.87	0.713115
W2 2	1.5	24.96028	0.06010	W2 2	0.21	121.23	0.001732	1.29	0.86

TABLE VII

DETERMINATION OF LENGTH REDUCTION FACTORS FOR REMOVAL OF UNCONSOLIDATED MATERIAL FROM EACH POND

Crawford Pond

Core	Length	Length-flock	Δ Length	% Reduction
C C-40	2.03	0.78	1.25	38.42%
C C-60	2.06	0.75	1.31	36.41%
C Dam	2.47	1.2	1.27	48.58%
C E-50	2.2	1	1.2	45.45%
C F-35	1.63	0.7	0.93	42.94%
C Head	1.67	0.7	0.97	41.92%
Mean Length Reduction				42.29%
Standard Deviation				0.04

Gunn Pond

Core	Length	Length-flock	Δ Length	% Reduction
G B-60	2.34	1.34	1	57.26%
G C-70	3.29	2.26	1.03	68.69%
G D-70	3.6	2.64	0.96	73.33%
G F-40	1.15	0.85	0.3	73.91%
G F-90	2.21	1.65	0.56	74.66%
Mean Length Reduction				69.57%
Standard Deviation				0.07

Hickory Grove Road

Core	Length	Length-flock	Δ Length	% Reduction
HG 1	2.55	0.71	1.84	27.84%
HG 10	2.48	1.1	1.38	44.35%
HG 11	3.28	1.43	1.85	43.60%
HG 2	3.15	1.1	2.05	34.92%
HG 3	2.42	1.28	1.14	52.89%
HG 4	2.83	1.42	1.41	50.18%
HG 5	2.36	1.21	1.15	51.27%
HG 6	2.99	1.04	1.95	34.78%
HG 8	3.1	1.75	1.35	56.45%
HG 9	4.77	1.53	3.24	32.08%
Mean Length Reduction				42.84%
Standard Deviation				0.10

McDevitte Pond

Core	Length	Length-flock	Δ Length	% Reduction
M A-45	3.645	0.82	2.825	22.50%
M A-80	2.63	0.52	2.11	19.77%
M C-60	1.12	0.85	0.27	75.89%
M E-34	2.075	1.21	0.865	58.31%
M G-23	1.34	0.47	0.87	35.07%
M I-17	1.59	0.75	0.84	47.17%
Mean Length Reduction				43.12%
Standard Deviation				0.22

Perry 1

Core	Length	Length-flock	Δ Length	% Reduction
P1 B1-A2	1.3	0.5	0.8	38.46%
P1 D-51	2.4	0.55	1.85	22.92%
P1 D-81	2.06	1	1.06	48.54%
P1 G-36	0.86	0.4	0.46	46.51%
P1 G-66	1.17	0.4	0.77	34.19%
P1 K-40	2.61	0.2	2.41	7.66%
P1 K-60	0.47	0.35	0.12	74.47%
P1 N1-M2	0.7	0.4	0.3	57.14%
Mean Length Reduction				41.24%
Standard Deviation				0.21

Perry 2

Core	Length	Length-flock	Δ Length	% Reduction
P2 B-46	1.88	0.65	1.23	34.57%
P2 C-30	3.56	1.1	2.46	30.90%
P2 D-30	2.32	0.9	1.42	38.79%
Mean Length Reduction				34.76%
Standard Deviation				0.04

Sullivan Pond

Core	Length	Length-flock	Δ Length	% Reduction
S 1	3.2	2.41	0.79	75.31%
S 2	1.99	1.85	0.14	92.96%
S 3	3.35	2.16	1.19	64.48%
S 4	1.65	1.51	0.14	91.52%
Mean Length Reduction				81.07%
Standard Deviation				0.14

Wilson 1

Core	Length	Length-flock	Δ Length	% Reduction
W1 B-40	5.64	2.3	3.34	40.78%
W1 D-32	6.11	2.46	3.65	40.26%
W1 D-51	6.16	1.94	4.22	31.49%
W1 F-34	3.14	1.85	1.29	58.92%
W1 F-54	5.17	2.1	3.07	40.62%
W1 H-40	3.93	2.6	1.33	66.16%
Mean Length Reduction				46.37%
Standard Deviation				0.13

Wilson 2

Core	Length	Length-flock	Δ Length	% Reduction
W2 2	1.22	0.35	0.87	28.69%
W2 2	1.5	0.21	1.29	14.00%
Mean Length Reduction				21.34%
Standard Deviation				0.10

TABLE VIII
VOLUMES OF VARIOUS POND SEDIMENTS

Pond Name	Land-use Intensity	Volume of Sediment (ft ³)		
		total submerged	sediment fringe	sediment without flocculent material
Crawford	Low	18,996.39	2,682.72	12,749
Gunn	Medium	14,827.00	261.31	11,983
Hickory Grove	Medium	59,815.00	2,529.00	42,738
McDevitte	Medium	27,306.00	194.40	8,476
Perry 1	High	78,389.94	82.35	37,118
Perry 2	Medium	8,058.42	1,256.58	5,260
Sullivan	High	13,243.10	3,558.87	10,935
Wilson 1	High	39,961.89	1,028.43	36,423
Wilson 2	Medium	3,695.95	679.19	2,235

The weight of sediment (tons) trapped in each pond was estimated by two different methods. First, the average pond bulk density values were multiplied by sediment volumes; and second, densities were distributed over the sediment depth measurements via a length to depth correlation. The distributed bulk density method was used to estimate both the total weight of pond sediments and the weight of consolidated sediments without the unconsolidated material.

The estimated sediment weight calculated with the average core densities is affected by inherent errors in the sampling process. Differences between the distribution of sampling locations and the distribution of sediment in the actual pond can introduce bias adversely affecting the weight estimate. Small errors in the determination of the bulk density of cores caused by either local sediment variations or measurement errors are another source of uncertainty. These small errors are accumulated throughout the sediment weight calculations and can significantly alter estimates of the rates of sedimentation.

The distributed density correlations were developed to minimize the errors anticipated in the average bulk density weight calculations. The correlations developed between sediment depth and density were used to calculate densities for each sediment depth measurement of the bathymetric survey. In this way, a larger number of calculated sediment densities were available to estimate the weight of sediment in the pond. Additionally, the larger number of density values were distributed over a larger area of the sediment layer. This increase in density values with their wider distribution reduces the discrepancy between sediment distribution and sampling distribution. The correlations also tend to minimize the effects of any erroneous density calculations by using a larger number of cores to estimate densities. TABLE IX shows the results of the calculations using various density distribution assumptions.

TABLE IX
WEIGHT OF POND SEDIMENTS FROM VARIOUS BULK DENSITY
DISTRIBUTION METHODS, TONS

Pond	Average Bulk Density	Distributed Bulk Density	Distributed Bulk Density -floc
Crawford	278.61	368.84	417.64
Gunn	242.22	191.81	287.16
Hickory Grove	753.99	822.18	1021.99
McDevitt	339.16	369.19	215.77
Perry 1	878.43	1068.92	964.17
Perry 2	182.49	138.57	151.02
Sullivan	312.34	293.46	324.58
Wilson 1	543.90	539.91	812.89
Wilson 2	74.46	80.87	79.10

The accuracy of the correlations between sediment core length and bulk density are described by standard regression analysis and confidence interval plots. As described previously the R^2 values and the standard errors as determined from the transformation from the log 10 domain as a percentage of the mean according to Tasker (1978) are reported in TABLE X. Plots of the 68-percent and 95-percent confidence intervals based on a fixed bin size of five cores are shown in FIGURES 31 and 32. As shown by the plots and descriptive statistics, the removal of the unconsolidated material improves the accuracy of the length to density correlations and the estimated pond sediment weight.

TABLE X
DESCRIPTIVE STATISTICS FOR LENGTH/DENSITY CORRELATIONS

	Total Sediment	Sediment-Floc
R^2	0.76	0.86
Standard Error	40.70%	30.60%

Sediment yields were calculated for each method and ranked according to the distributed bulk density obtained after the unconsolidated material was removed from the estimate. Gross correlations between land-use intensity and sediment yields confirmed expectations; as intensity of use increases, sediment yields tend to increase, as shown in TABLE XI.

Examination of the pond core-based method calculations of sediment yield rate showed relatively tight ranges for all three methods, and small standard deviations among the derived bulk densities and estimated erosion/sedimentation rates are listed in TABLE XI, where FIGURE 33 shows the results of the calculations in graphical form. This result suggests a degree of robustness within the various core-based methods. These results are

consistent with observed field conditions, although more investigation is needed to relate field conditions to a predictive model accurately.

TABLE XI
COMPARISONS OF HILLSLOPE SEDIMENT YIELD (tons/acre/year) RESULTS
FOR THE DIFFERENT RATE DETERMINATION METHODS

Pond	Land-use Intensity	Average Bulk Density	Distributed Bulk Density	Distributed Bulk Density -floc	mean	Standard Deviation		RUSLE2
Wilson 2	Medium	0.71	0.77	0.76	0.75	0.03		3.10
Crawford	Low	0.58	0.77	0.87	0.74	0.15		0.94
McDevitte	Medium	1.38	1.51	0.88	1.26	0.33		4.30
Perry 2	Medium	1.72	1.08	1.17	1.32	0.35		2.90
Gunn	Medium	1.03	0.82	1.22	1.02	0.20		0.81
Perry 1	High	1.60	1.78	1.67	1.68	0.09		4.30
Sullivan	High	2.04	1.92	2.13	2.03	0.10		2.40
Wilson 1	High	1.90	1.89	2.78	2.19	0.51		2.50
Hickory Grove	Medium	2.94	3.20	3.98	3.37	0.54		5.50

The sediment yield calculated from the sediment trapped in each of the ponds was compared to sediment yields based on RUSLE2 models of each site. Divergence between the sediment yields obtained from the core methods and yields obtained from RUSLE2 results tended to vary from site to site. Sedimentation rates derived from RUSLE2 models for several drainages—Crawford, Gunn, and Wilson 1—are within the range of the rates derived from the pond core methods and the result for the Sullivan drainage is just outside of that range. The rate results for the other drainages—Hickory Grove Road, Wilson 2, Perry 1 and 2, and McDevitte—vary considerably from the rates obtained from the core-based methods. RUSLE2 predictions at Perry 2 are over three times greater than the values obtained from the core-based methods.

A summary of conditions and sediment yield results for the various locations appears in TABLE XII.

TABLE XII

SUMMARY OF BULK DENSITY AND SEDIMENT TRANSPORT RESULTS FROM THE VARIOUS ANALYSES FOR EACH POND

Pond Summary Table:

Pond Name	Age of Pond years	Drainage Area acres	Land Disturbance	Volume of Sediment		Sediment Yield (tons/acre/year) and Bulk Density (lbs/ft ³)									
						Average Bulk Density		Distributed Bulk Density		Volume -floc	Distributed Bulk Density -floc		RUSLE2 tons/acre/year	Slope	
						Yield	Bulk Density	Yield	Bulk Density		Yield	Bulk Density		Distance, ft	Slope %
pond ft ³	sed toe ft ³														
Crawford	57	8.41	Low Never Grazed	18,996.39	2,682.72	0.58	16.10	0.77	25.60	12,749	0.87	93.7	0.94	290	14.2%
Gunn	25	9.40	Med Limited Grazing in past	14,827.00	261.31	1.03	31.60	0.82	24.80	11,983	1.22	60.87	0.81	252	12.5%
Hickory Grove	45	5.70	Med Grazing	59,815.00	2,529.00	2.94	22.12	3.20	24.40	42,738	3.98	73.1	5.50	211.3	19.3%
McDevitte	49	4.99	Med Limited Grazing	27,306.00	194.40	1.38	24.3	1.51	26.50	8,476	0.88	76	4.30	144.2	14.8%
Perry 1	15	39.99	High Grazing	78,389.94	82.35	1.60	22.34	1.78	27.20	37,118	1.67	68.3	4.30	532.5	12.4%
Perry 2	77	1.67	Med Limited Grazing in past	8,058.42	1,256.58	1.72	37.90	1.08	27.00	5,260	1.17	47.4	2.90	98.9	12.2%
Sullivan	39	3.91	High High Ammt of Grazing	13,243.10	3,558.87	2.05	30.75	1.92	27.90	10,935	2.13	61.1	2.40	202.3	11.7%
Wilson 1	27	10.57	High Some Construction	39,961.89	1,028.43	1.9	24.60	1.89	24.40	36,423	2.84	101.85	2.50	253	6.9%
Wilson 2	20	5.22	Med No grazing	3,695.95	679.19	0.71	25.13	0.77	28.60	2,235	0.76	82.5	3.10	501.4	12.0%

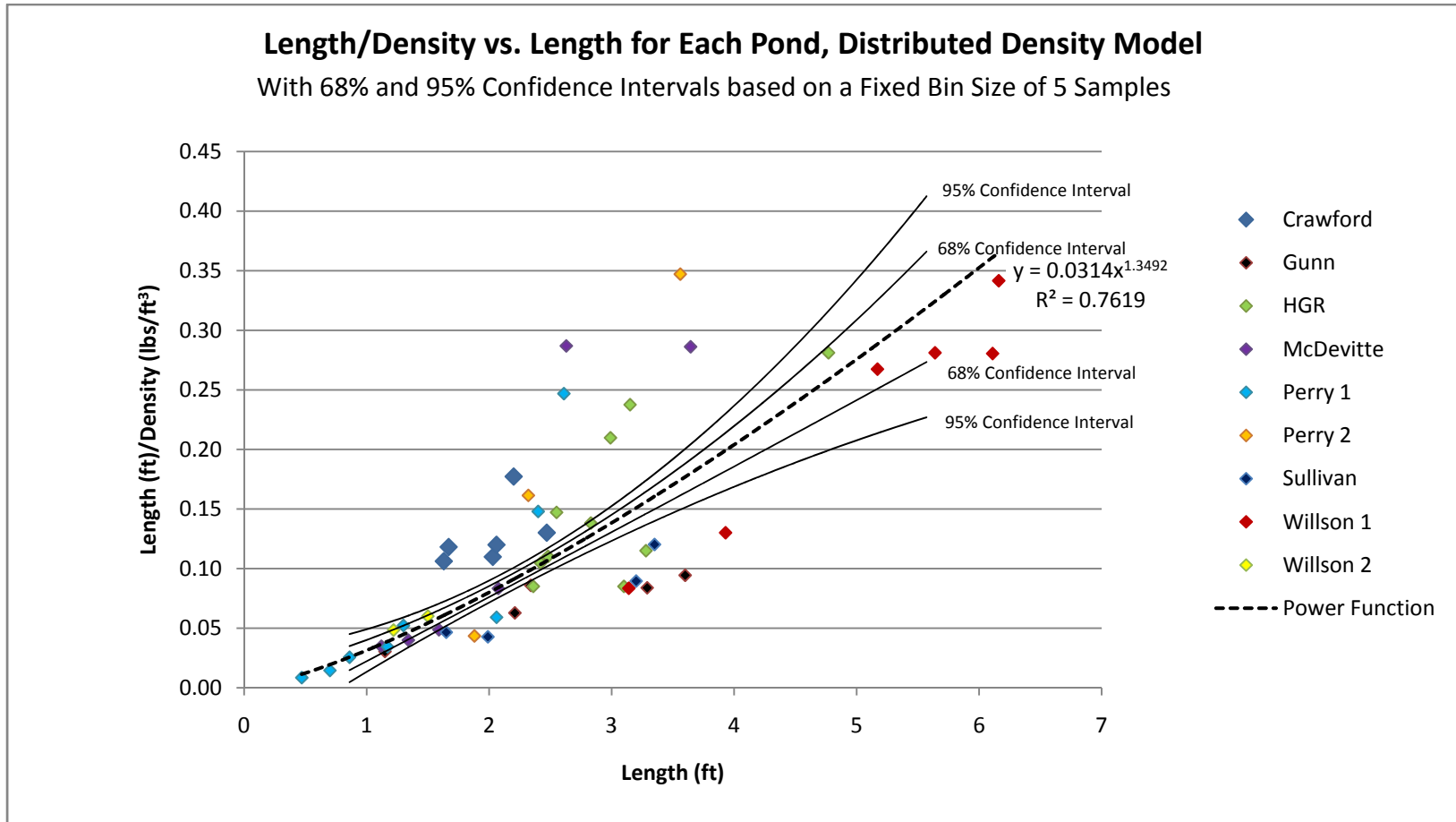

FIGURE 31 - Regression analysis of normalized density for pond cores showing the relationship of each pond-specific core's distribution to the overall bulk density distribution

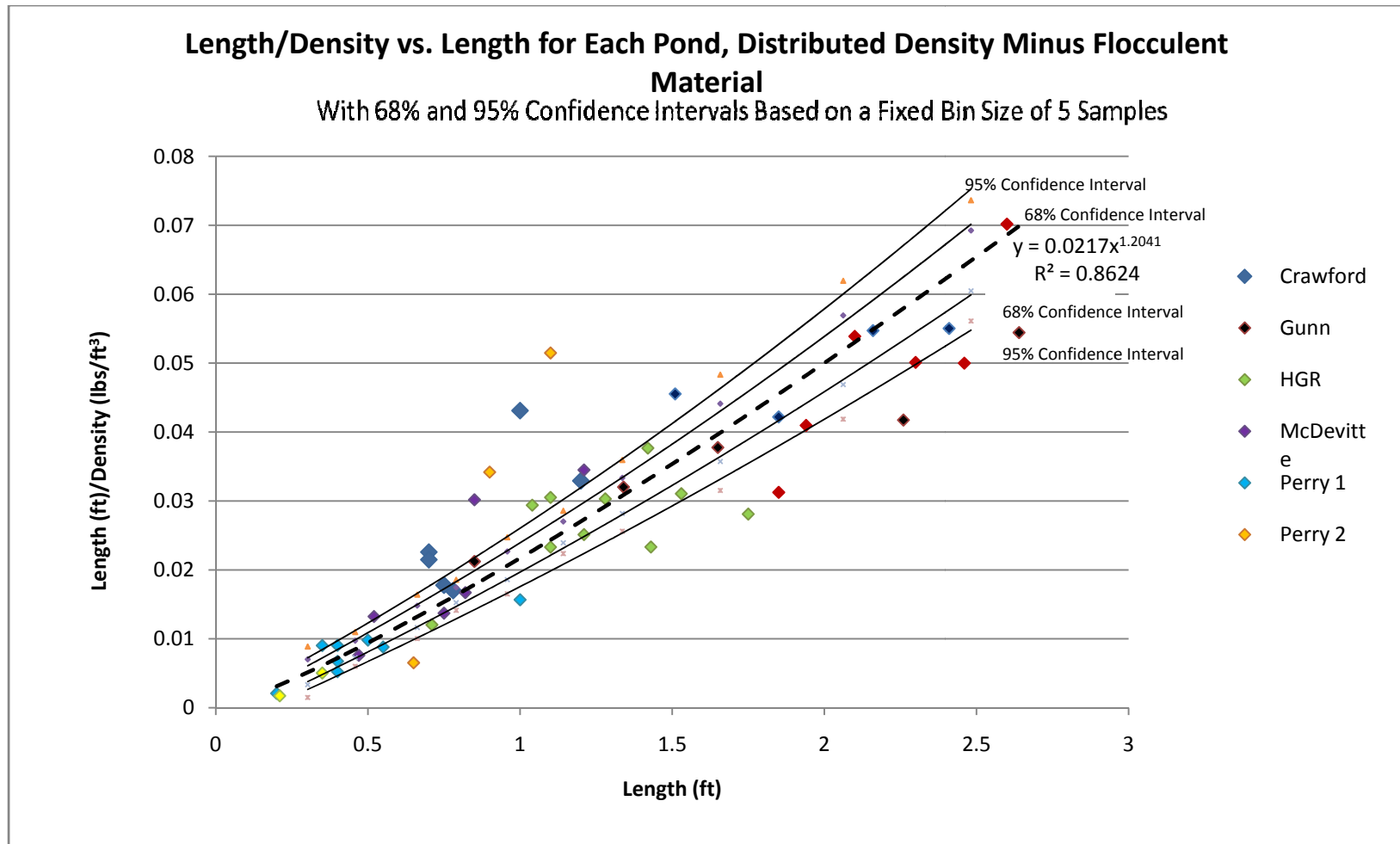

FIGURE 32 - Regression analysis of normalized density for pond cores, with their unconsolidated layer removed, showing the relationship of each pond-specific core's distribution to the overall bulk density distribution

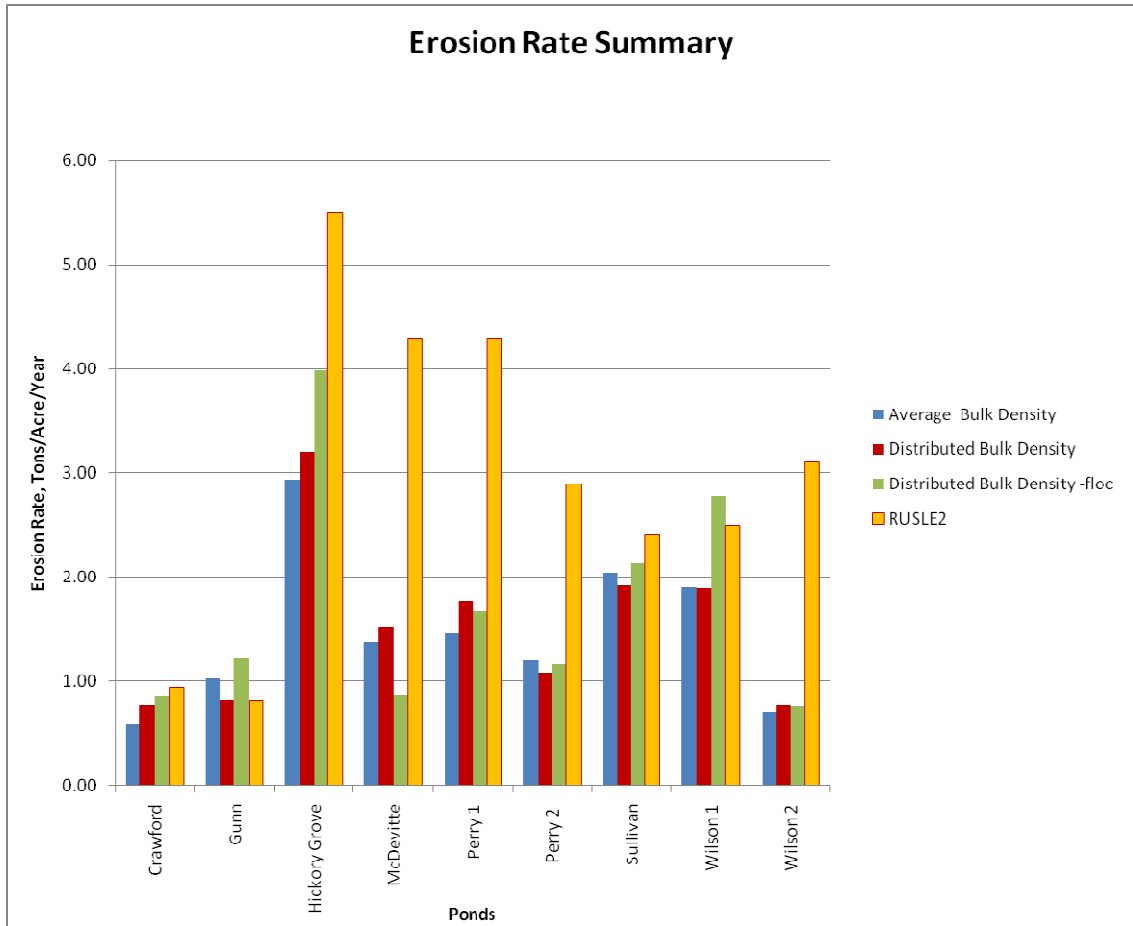

FIGURE 33 - Summary graph of calculated erosion rates

V. CONCLUSIONS

Determining the amount of sediment in a stream produced from the erosion of adjacent hillslopes is challenging because of the dynamic nature of sediment transport and deposition. By measuring sediment trapped in farm ponds at the base of hillslopes and equating this amount of sediment to the sediment transported to gullies and channels downstream from the ponds, it is possible to avoid some of the problems of transport efficiency, uncertainty about hillslope deposition, and short-term variations in erosion rates.

A method for determining the weight of sediment stored in a pond was developed based on a correlation between sediment depth and bulk density. This correlation was applied to sediment depth measurements in hopes of reducing bias introduced by differences between the distribution of sediment and sampling location distribution. Furthermore, the unconsolidated nonconsolidated material at the tops of the sediment samples was removed from calculations reducing the influence of recent short-term variations in sediment delivery rates.

Calculated sediment yields were compared to observed land-use intensities, as shown previously in TABLE XII. Although the effect of the slope and length of the hillside on erosion were not examined, the calculated sediment yields were fairly consistent with the observed land-use intensities. Higher land-use intensities increased erosion resulting in higher sediment yields.

The calculated sediment yields also were compared to predictions of yields based on the RUSLE2 soil loss model. In most cases, RUSLE2 predicted higher sediment yields than those estimated with the pond core-based methods.

The pond coring method provides a relatively accurate estimation of sediment trapped in a small pond. Relatively quick and inexpensive, this method can yield reasonable data for hillslope sediment yield. Used directly or as a calibration for models such as RUSLE2, these pond coring techniques predict sediment yields from farm ponds that can provide land-use managers with necessary information regarding sources and amounts of stream sediments.

REFERENCES:

- American Society of Civil Engineers. 2000. *Soil Sampling*. American Society of Civil Engineers as Adapted from the U.S. Army Corps of Engineers, No. 30.
- American Society of Civil Engineers. 2008. *Sedimentation Engineering*. American Society of Civil Engineers Manual No. 110. V.A. Vanoni, editor.
- Blanton, J.O., III. 1982. "Procedures for Monitoring Reservoir Sedimentation." Bureau of Reclamation, Denver, Colorado.
- Brady, N.C. 1984. *The Nature and Properties of Soils*, 9. Macmillan Publishing Co. New York. pp.750.
- Bureau of Reclamation, 2006. *Erosion and Sedimentation Manual*. Denver, Colorado.
- Cressman, E. R. and Peterson, W. L., 2001. "Contributions to the Geology of Kentucky, Ordovician System." U.S. Geological Survey Professional Paper 1151-H, Online Version 1.0, <http://pubs.usgs.gov/pp/p1151h/contents.html>; accessed 9 March 2008.
- Davis, D. H. 1927. *The Geography of the Blue Grass Region of Kentucky*. The Kentucky Geological Survey, Frankfort, Kentucky.
- Holtz, R. D. and Kovacs, W.D. 1981. *An Introduction to Geotechnical Engineering*. Prentice Hall: Upper Saddle River, New Jersey.
- Knighton, D. 1998. *Fluvial Forms and Processes, a New Perspective*. Arnold Press, London.
- KYGEONET. Kentucky Geography Network. 2009 <http://kygeonet.ky.gov/>; accessed 10 February 2009.
- McKean, C.J.P. and Nordin, R. N. 1986. "A Simple Semi-Continuous Piston Corer for Organic Sediments." *Hydrobiologia*, Vol. 137: pp. 251-256
- Moore, F.B. 1975. *Geologic Map of the Frankfort West Quadrangle, Franklin and Anderson Counties, Kentucky*. U.S. Department of the Interior, U.S. Geological Survey: Reston, Virginia.
- National Resources Conservation Service. Websoil survey. Natural Resources Conservation Service, U.S. Department of Agriculture. 2008. <http://websoilsurvey.nrcs.usda.gov/app/WebSoilSurvey.aspx>; accessed 10 January 2009.
- Peterson, W. L. 2001. "Contributions to the Geology of Kentucky, Silurian System." U.S. Geological Survey Professional Paper 1151-H, Online Version 1.0, <http://pubs.usgs.gov/pp/p1151h/contents.html>; accessed 8 December 2007.

- USDA-ARS. 2005. "Revised Universal Soil Loss Equation 2 - Overview of RUSLE2." U.S. Department of Agriculture-Agricultural Research Service, <http://www.ars.usda.gov/Research/docs.htm?docid=6010>; accessed 25 January 2008.
- U.S. Environmental Protection Agency. National Assessment Database, Assessment Data for the State of Kentucky Year 2004. http://oaspub.epa.gov/tmdl/w305b_report_v4.state?p_state=KY&p_cycle=2004#source; accessed May 2008.
- U.S. Environmental Protection Agency Polluted Runoff (Nonpoint Source Pollution) 2008. <http://www.epa.gov/nps/education/runoff.html>; accessed 10 July 2008.
- USGS. The National Map Seamless Server. 2008. U.S. Department of the Interior. U.S. Geological Survey, <http://seamless.usgs.gov/index.php>, accessed 22 September 2008.
- Verstraeten, G. and Poesen, J., 2001. "Modeling the Long-Term Sediment Trap Efficiency of Small Ponds." *Hydrological Processes*. Vol. 15: pp. 2797-2819.
- Wilson, L.S. 1941. "Land Use Patterns of the Inner Bluegrass." *Economic Geography*, Vol. 17 No. 3. pp. 287-296.
- Wischmeier, W. H. and Smith, D. D. 1978. "Predicting Rainfall-Erosion Losses: A Guide to Conservation Planning. Agriculture Handbook (AH) 537. U.S. Department of Agriculture, Washington, D.C.

APPENDIX I. POND BULK DENSITY SUMMARY INFORMATION

TABLE XIII (a)

BULK DENSITY SUMMARY INFORMATION, HICKORY GROVE POND

Hickory Grove Pond

Core X Section

Core 1

	Length, ft	Mass, g	- Flock
core water		0	
floc	0.3	22.639	
Sediment Top	0.71	415.693	
Sediment Bottom			
Sub Sediment	0.04	40.391	
Total Coe Length	1.05		
Total Sed Length	1.01		
Total Sed Mass		438.332	415.693
in situ length, ft	2.55		0.71
Area of in situ core, ft ²	0.055632		0.01549
in situ density, g/ft ³	7879.089		26836.6
	17.33399 lbs/ft ³		59.0405 lbs/ft ³

Core X Section

Core 2

	Length, ft	Mass, g	- Flock
core water		0	
floc	0.09	21.006	
Sediment Top	1.1	393.377	
Sediment Bottom			
Sub Sediment	0.05	52.528	
Total Coe Length	1.24		
Total Sed Length	1.19		
Total Sed Mass		414.383	393.377
in situ length, ft	3.15		1.1
Area of in situ core, ft ²	0.068722		0.023998
in situ density, g/ft ³	6029.82		16391.9
	13.2656 lbs/ft ³		36.06218 lbs/ft ³

Core X Section

Core 3

	Length, ft	Mass, g	- Flock
core water		0	
floc	0.06	18.865	
Sediment Top	1.28	536.142	
Sediment Bottom			
Sub Sediment	0.12	58.49	
Total Coe Length	1.46		
Total Sed Length	1.34		
Total Sed Mass		555.007	536.142
in situ length, ft	2.42		1.28
Area of in situ core, ft ²	0.052796		0.02793
in situ density, g/ft ³	10512.26		19199.2
	23.12697 lbs/ft ³		42.2382 lbs/ft ³

Core X Section

Core 4

	Length, ft	Mass, g	- Flock
core water		31.811	
floc	0.04	12.712	
Sediment Top	1.42	530.46	
Sediment Bottom			
Sub Sediment	0.25	404.759	
Total Coe Length	1.71		
Total Sed Length	1.46		
Total Sed Mass		574.983	530.46
in situ length, ft	2.83		1.42
Area of in situ core, ft ²	0.061741		0.03098
in situ density, g/ft ³	9312.827		17122.9
	20.48822 lbs/ft ³		37.67038 lbs/ft ³

Core X Section

Core 5

	Length, ft	Mass, g	- Flock
core water		45.982	
floc	0.06	25.249	
Sediment Top	1.21	578.059	
Sediment Bottom			
Sub Sediment	0.16	112.487	
Total Coe Length	1.43		
Total Sed Length	1.27		
Total Sed Mass		649.29	578.059
in situ length, ft	2.36		1.21
Area of in situ core, ft ²	0.051487		0.0264
in situ density, g/ft ³	12610.71		21897.8
	27.74357 lbs/ft ³		48.1751 lbs/ft ³

Core X Section

Core 6

	Length, ft	Mass, g	- Flock
core water		24.154	
floc	0.13	33.635	
Sediment Top	1.04	365.04	
Sediment Bottom			
Sub Sediment	0.35	287.015	
Total Coe Length	1.52		
Total Sed Length	1.17		
Total Sed Mass		422.829	365.04
in situ length, ft	2.99		1.04
Area of in situ core, ft ²	0.065232		0.022689
in situ density, g/ft ³	6481.963		16088.67
	14.26032 lbs/ft ³		35.39507 lbs/ft ³

Core X Section

Core 7

	Length, ft	Mass, g	- Flock
core water			
floc	0.05		
Sediment Top	0.82		
Sediment Bottom			
Sub Sediment	0.22		
Total Coe Length	1.09		
Total Sed Length	0.87		
Total Sed Mass		0	0
in situ length, ft	3.7		0.82
Area of in situ core, ft ²	0.080721		0.01789
in situ density, g/ft ³	0		0
	0 lbs/ft ³		0 lbs/ft ³

Core X Section

Core 8

	Length, ft	Mass, g	- Flock
core water		7.44	
floc	0.04	31.81	
Sediment Top	1.75	924.859	
Sediment Bottom			
Sub Sediment	0.41	157.009	
Total Coe Length	2.2		
Total Sed Length	1.79		
Total Sed Mass		1121.118	1081.868
in situ length, ft	3.1		1.75
Area of in situ core, ft ²	0.067631		0.038179
in situ density, g/ft ³	16576.87		28336.7
	36.46912 lbs/ft ³		62.34073 lbs/ft ³

TABLE XIII (b)

BULK DENSITY SUMMARY INFORMATION, HICKORY GROVE POND

Core X Section				Core X Section			
Core 9				Core 10			
	Length, ft	Mass, g	- Flock		Length, ft	Mass, g	- Flock
core water				core water			
floc	0.14	55.12		floc	0.01	38.417	
Sediment Top	1.53	747.77		Sediment Top	1.1	515.054	
Sediment Bottom				Sediment Bottom			
Sub Sediment	0.15	91.632		Sub Sediment	0.35	154.805	
Total Coe Length	1.82			Total Coe Length	1.46		
Total Sed Length	1.67			Total Sed Length	1.11		
Total Sed Mass		802.89	747.77	Total Sed Mass		553.471	515.054
in situ length, ft	4.77		1.53	in situ length, ft	2.48		1.1
Area of in situ core, ft ²	0.104065		0.03338	Area of in situ core, ft ²	0.054105		0.023998
in situ density, g/ft ³	7715.262		22402.1	in situ density, g/ft ³	10229.54		21462.14
	16.97358 lbs/ft ³		49.2847 lbs/ft ³		22.50499 lbs/ft ³		47.21671 lbs/ft ³
Core X Section				Average Results			
Core 11							
	Length, ft	Mass, g	- Flock				
core water		36.209		in situ length, ft	2.993	-Flock	1.257
floc	0.08	22.088		Area of in situ core, ft ²	0.065297		0.027423
Sediment Top	1.43	683.255		in situ density, g/ft ³	10031.82		21761.83
Sediment Bottom				lb/ft	22.06999		47.87602
Sub Sediment	0.3	186.547					
Total Coe Length	1.81						
Total Sed Length	1.51						
Total Sed Mass		928.099	869.802				
in situ length, ft	3.28		1.43				
Area of in situ core, ft ²	0.071558		0.0312				
in situ density, g/ft ³	12969.81		27880.3				
	28.53357 lbs/ft ³		61.3366 lbs/ft ³				

TABLE XIV

BULK DENSITY SUMMARY INFORMATION, SULLIVAN POND

Sullivan Pond (Complete)

Core X Section

Core 1	Length, ft	Mass, g	- Flock
core water		23.08	
floc	0.03	64.219	
Sediment Top	2.41	1046.64	
Sediment Bottom			
Sub Sediment	0.04	10.416	
Total Coe Length	2.48		
Total Sed Length	2.44		
Total Sed Mass		1133.939	1046.64
in situ length, ft	3.2		2.41
Area of in situ core, ft ²	0.069813		0.05258
in situ density, g/ft ³	16242.49		19906.4
	35.73349 lbs/ft ³		43.7941 lbs/ft ³

Core X Section

Core 2	Length, ft	Mass, g	- Flock
core water		14.1007	
floc	0.07	99.213	
Sediment Top	1.85	804.269	
Sediment Bottom			
Sub Sediment	0.07	74.853	
Total Coe Length	1.99		
Total Sed Length	1.92		
Total Sed Mass		917.5827	804.269
in situ length, ft	2.99		1.85
Area of in situ core, ft ²	0.065232		0.040361
in situ density, g/ft ³	14066.53		19927.03
	30.94637 lbs/ft ³		43.83947 lbs/ft ³

Core X Section

Core 3	Length, ft	Mass, g	- Flock
core water			
floc	0.01	80.927	
Sediment Top	2.16	844.74	
Sediment Bottom			
Sub Sediment	0.63	395.418	
Total Coe Length	2.8		
Total Sed Length	2.17		
Total Sed Mass		925.667	844.74
in situ length, ft	3.35		2.16
Area of in situ core, ft ²	0.073086		0.04712
in situ density, g/ft ³	12665.52		17926
	27.86414 lbs/ft ³		39.4371 lbs/ft ³

Core X Section

Core 4	Length, ft	Mass, g	- Flock
core water			
floc	0.09	82.263	
Sediment Top	1.51	496.577	
Sediment Bottom			
Sub Sediment	0.05	29.937	
Total Coe Length	1.65		
Total Sed Length	1.6		
Total Sed Mass		578.84	496.577
in situ length, ft	2.07		1.51
Area of in situ core, ft ²	0.04516		0.032943
in situ density, g/ft ³	12817.44		15073.8
	28.19836 lbs/ft ³		33.16235 lbs/ft ³

Average Results

in situ length, ft	2.9025	-Flock	1.9825
Area of in situ core, ft ²	0.063323		0.04325
in situ density, g/ft ³	13947.99		18208.3
lb/ft	30.68559		40.0583

TABLE XV

BULK DENSITY SUMMARY INFORMATION, CRAWFORD POND

Crawford Pond (Complete)

Core X Section			
C-40	Length, ft	Mass, g	- Flock
core water			
floc	0.22	16.8	
Sediment Top	0.78	202.179	
Sediment Bottom		152.947	
Sub Sediment	0	0	
Total Coe Length	1		
Total Sed Length	1		
Total Sed Mass		371.926	355.126
in situ length, ft	2.03		0.78
Area of in situ core, ft ²	0.044288		0.01702
in situ density, g/ft ³	8397.954		20869
	18.4755 lbs/ft ³		45.9117 lbs/ft ³

Core X Section			
C-60	Length, ft	Mass, g	- Flock
core water			
floc	0.2	36.599	
Sediment Top	0.75	177.979	
Sediment Bottom		136.112	
Sub Sediment	0.3	9.616	
Total Coe Length	1.25		
Total Sed Length	0.95		
Total Sed Mass		350.69	314.091
in situ length, ft	2.06		0.75
Area of in situ core, ft ²	0.044942		0.016362
in situ density, g/ft ³	7803.135		19195.84
	17.1669 lbs/ft ³		42.23086 lbs/ft ³

Core X Section			
E-50	Length, ft	Mass, g	- Flock
core water			
floc	0.2	40.6	
Sediment Top	1	112.171	
Sediment Bottom		117.905	
Sub Sediment	0.1	14.649	
Total Coe Length	1.3		
Total Sed Length	1.2		
Total Sed Mass		270.676	230.076
in situ length, ft	2.2		1
Area of in situ core, ft ²	0.047997		0.02182
in situ density, g/ft ³	5639.493		10545.9
	12.40688 lbs/ft ³		23.201 lbs/ft ³

Core X Section			
F-35	Length, ft	Mass, g	- Flock
core water			
floc	0.2	32.84	
Sediment Top	0.7	85.617	
Sediment Bottom		129.637	
Sub Sediment	0.1	0	
Total Coe Length	1		
Total Sed Length	0.9		
Total Sed Mass		248.094	215.254
in situ length, ft	1.63		0.7
Area of in situ core, ft ²	0.035561		0.015272
in situ density, g/ft ³	6976.565		14095.04
	15.34844 lbs/ft ³		31.00908 lbs/ft ³

Core X Section			
Dam	Length, ft	Mass, g	- Flock
core water			
floc	0.1	31.032	
Sediment Top	1.2	226.519	
Sediment Bottom		207.37	
Sub Sediment	0	0	
Total Coe Length	1.3		
Total Sed Length	1.3		
Total Sed Mass		464.921	433.889
in situ length, ft	2.47		1.2
Area of in situ core, ft ²	0.053887		0.02618
in situ density, g/ft ³	8627.703		16573.4
	18.98095 lbs/ft ³		36.4614 lbs/ft ³

Core X Section			
Head of Pond	Length, ft	Mass, g	- Flock
core water			
floc	0.1	7.719	
Sediment Top	0.7	73.699	
Sediment Bottom		152.634	
Sub Sediment	0	0	
Total Coe Length	0.8		
Total Sed Length	0.8		
Total Sed Mass		234.052	226.333
in situ length, ft	1.67		0.7
Area of in situ core, ft ²	0.036434		0.015272
in situ density, g/ft ³	6424.049		14820.5
	14.13291 lbs/ft ³		32.6051 lbs/ft ³

Average Results			
in situ length, ft	2.01	-Flock	0.855
Area of in situ core, ft ²	0.043851		0.01865
in situ density, g/ft ³	7311.483		16016.6
lb/ft	16.08526		35.5882

TABLE XVI

BULK DENSITY SUMMARY INFORMATION, WILSON 1 POND

Wilson 1 (Complete)

Core X Section			
B-40			
	Length, ft	Mass, g	- Flock
core water		27.89	
floc	0.25	47.252	
Sediment Top	2.3	448.912	
Sediment Bottom		598.201	
Sub Sediment	0.15	33.398	
Total Coe Length	2.7		
Total Sed Length	2.55		
Total Sed Mass		1122.255	1047.11
in situ length, ft	5.64		2.3
Area of in situ core, ft ²	0.123046		0.05018
in situ density, g/ft ³	9120.642		20867.9
	20.06541 lbs/ft ³		45.9094 lbs/ft ³

Core X Section			
D-32			
	Length, ft	Mass, g	- Flock
core water		13.35	
floc	0.1	106.311	
Sediment Top	2.46	587.075	
Sediment Bottom		613.292	
Sub Sediment	0.052	6.789	
Total Coe Length	2.612		
Total Sed Length	2.56		
Total Sed Mass		1320.028	1200.367
in situ length, ft	6.11		2.46
Area of in situ core, ft ²	0.133299		0.053669
in situ density, g/ft ³	9902.73		22366.19
	21.78601 lbs/ft ³		49.20561 lbs/ft ³

Core X Section			
D-51			
	Length, ft	Mass, g	- Flock
core water		45.96	
floc	3.3	144.5	
Sediment Top	1.94	501.186	
Sediment Bottom		410.088	
Sub Sediment	0.045		
Total Coe Length	5.285		
Total Sed Length	5.24		
Total Sed Mass		1101.734	911.274
in situ length, ft	6.16		1.94
Area of in situ core, ft ²	0.13439		0.04232
in situ density, g/ft ³	8198.021		21530.8
	18.03565 lbs/ft ³		47.3678 lbs/ft ³

Core X Section			
F-34			
	Length, ft	Mass, g	- Flock
core water		35.4	
floc	0.3	49.351	
Sediment Top	1.85	491.555	
Sediment Bottom		594.546	
Sub Sediment	0.12		
Total Coe Length	2.27		
Total Sed Length	2.15		
Total Sed Mass		1170.852	1086.101
in situ length, ft	3.14		1.85
Area of in situ core, ft ²	0.068504		0.040361
in situ density, g/ft ³	17091.7		26909.86
	37.60175 lbs/ft ³		59.2017 lbs/ft ³

Core X Section			
H-40			
	Length, ft	Mass, g	- Flock
core water		47.9	
floc	0.3	174.122	
Sediment Top	2.6	485.46	
Sediment Bottom		469.723	
Sub Sediment	0.04	12.332	
Total Coe Length	2.94		
Total Sed Length	2.9		
Total Sed Mass		1177.205	955.183
in situ length, ft	3.93		2.6
Area of in situ core, ft ²	0.085739		0.05672
in situ density, g/ft ³	13730.06		16839.4
	30.20614 lbs/ft ³		37.0466 lbs/ft ³

Core X Section			
F-54			
	Length, ft	Mass, g	- Flock
core water		36	
floc	0.25	143.869	
Sediment Top	2.1	356.869	
Sediment Bottom		454.771	
Sub Sediment	0.14	96.17	
Total Coe Length	2.49		
Total Sed Length	2.35		
Total Sed Mass		991.509	811.64
in situ length, ft	5.17		2.1
Area of in situ core, ft ²	0.112792		0.045815
in situ density, g/ft ³	8790.612		17715.65
	19.33935 lbs/ft ³		38.97443 lbs/ft ³

Average Results			
in situ length, ft	5.025	-Flock	2.20833
Area of in situ core, ft ²	0.109628		0.04818
in situ density, g/ft ³	11138.96		21038.3
lb/ft	24.50572		50.4211

TABLE XVII

BULK DENSITY SUMMARY INFORMATION, WILSON 2 POND

Wilson 2 (Complete)

Core X Section			
Core 1			
	Length, ft	Mass, g	- Flock
core water		30.965	
floc	0.2	99.544	
Sediment Top	0.35	240.774	
Sediment Bottom			
Sub Sediment	0.09	7.304	
Total Coe Length	0.64		
Total Sed Length	0.55		
Total Sed Mass		371.283	240.774
in situ length, ft	1.5		0.35
Area of in situ core, ft ²	0.032725		0.00764
in situ density, g/ft ³	11345.58		31532.2
	24.96028 lbs/ft ³		69.3709 lbs/ft ³

Core X Section			
Core 2			
	Length, ft	Mass, g	- Flock
core water		26.7	
floc	0.2	25.701	
Sediment Top	0.21	117.55	
Sediment Bottom		134.895	
Sub Sediment	0.09	58.056	
Total Coe Length	0.5		
Total Sed Length	0.41		
Total Sed Mass		304.846	252.445
in situ length, ft	1.22		0.21
Area of in situ core, ft ²	0.026616		0.004581
in situ density, g/ft ³	11453.38		55101.12
	25.19744 lbs/ft ³		121.2225 lbs/ft ³

Average Results			
in situ length, ft	1.36	-Flock	0.28
Area of in situ core, ft ²	0.029671		0.00611
in situ density, g/ft ³	11399.48		43316.7

TABLE XVIII

BULK DENSITY SUMMARY INFORMATION, GUNN POND

Gunn Pond (Complete)

Core X Section

B-60	Length, ft	Mass, g	- Flock
core water		15.09	
floc	0.15	60.814	
Sediment Top	1.34	298.53	
Sediment Bottom		257.54	
Sub Sediment	0.22	140.199	
Total Coe Length	1.71		
Total Sed Length	1.49		
Total Sed Mass		631.974	556.07
in situ length, ft	2.34		1.34
Area of in situ core, ft ²	0.051051		0.02923
in situ density, g/ft ³	12379.31		19021.2
	27.23448 lbs/ft ³		41.8466 lbs/ft ³

Core X Section

C-70	Length, ft	Mass, g	- Flock
core water		23.0194	
floc	0.1	43.285	
Sediment Top	2.26	878.641	
Sediment Bottom		334.904	
Sub Sediment	0.11	114.892	
Total Coe Length	2.47		
Total Sed Length	2.36		
Total Sed Mass		1279.849	1213.545
in situ length, ft	3.29		2.26
Area of in situ core, ft ²	0.071777		0.049306
in situ density, g/ft ³	17831.01		24612.77
	39.22822 lbs/ft ³		54.14809 lbs/ft ³

Core X Section

D-70	Length, ft	Mass, g	- Flock
core water		37.14	
floc	0	53.778	
Sediment Top	2.64	575.023	
Sediment Bottom		695.541	
Sub Sediment	0.03	53.312	
Total Coe Length	2.67		
Total Sed Length	2.64		
Total Sed Mass		1361.482	1270.56
in situ length, ft	3.6		2.64
Area of in situ core, ft ²	0.07854		0.0576
in situ density, g/ft ³	17334.94		22060
	38.13687 lbs/ft ³		48.532 lbs/ft ³

Core X Section

F-90	Length, ft	Mass, g	- Flock
core water		41.89	
floc	0.2	14.166	
Sediment Top	1.65	354.885	
Sediment Bottom		360.158	
Sub Sediment	0	0	
Total Coe Length	1.85		
Total Sed Length	1.85		
Total Sed Mass		771.099	715.043
in situ length, ft	2.21		1.65
Area of in situ core, ft ²	0.048215		0.035997
in situ density, g/ft ³	15993.03		19863.75
	35.18467 lbs/ft ³		43.70025 lbs/ft ³

Core X Section

F-40	Length, ft	Mass, g	- Flock
core water		43.22	
floc	0.3	49.677	
Sediment Top	0.85	206.443	
Sediment Bottom		131.262	
Sub Sediment	0	0	
Total Coe Length	1.15		
Total Sed Length	1.15		
Total Sed Mass		430.602	337.705
in situ length, ft	2.45		0.85
Area of in situ core, ft ²	0.053451		0.01854
in situ density, g/ft ³	8056.065		18210.9
	17.72334 lbs/ft ³		40.064 lbs/ft ³

Average Results

in situ length, ft	2.778	-Flock	1.748
Area of in situ core, ft ²	0.060607		0.038135
in situ density, g/ft ³	14318.87		20753.72
lb/ft	31.50152		47.05674

TABLE XIX

BULK DENSITY SUMMARY INFORMATION, McDEVITTE POND

McDevitt Pond (Complete)

Core X Section			
A-80	Length, ft	Mass, g	- Flock
core water		8.6	
floc	0.09	27.983	
Sediment Top	0.52	95.854	
Sediment Bottom		106.68	
Sub Sediment	0.12	91.025	
Total Coe Length	0.73		
Total Sed Length	0.61		
Total Sed Mass		239.117	202.534
in situ length, ft	2.63		0.52
Area of in situ core, ft ²	0.057378		0.01134
in situ density, g/ft ³	4167.424		17852.9
	9.168333 lbs/ft ³		39.2763 lbs/ft ³

Core X Section			
A-45	Length, ft	Mass, g	- Flock
core water		9.98	
floc	0.1	51.147	
Sediment Top	0.82	162.203	
Sediment Bottom		237.137	
Sub Sediment	0.11	101.627	
Total Coe Length	1.03		
Total Sed Length	0.92		
Total Sed Mass		460.467	399.34
in situ length, ft	3.645		0.82
Area of in situ core, ft ²	0.079521		0.01789
in situ density, g/ft ³	5790.472		22322.45
	12.73904 lbs/ft ³		49.1094 lbs/ft ³

Core X Section			
C-60	Length, ft	Mass, g	- Flock
core water		19.557	
floc	0.1	100.626	
Sediment Top	0.85	159.915	
Sediment Bottom		77.522	
Sub Sediment	0.17	91.775	
Total Coe Length	1.12		
Total Sed Length	0.95		
Total Sed Mass		357.62	237.437
in situ length, ft	1.12		0.85
Area of in situ core, ft ²	0.024435		0.01854
in situ density, g/ft ³	14635.81		12803.9
	32.19878 lbs/ft ³		28.1686 lbs/ft ³

Core X Section			
E-34	Length, ft	Mass, g	- Flock
core water		25.377	
floc	0.3	66.041	
Sediment Top	1.21	206.057	
Sediment Bottom		214.795	
Sub Sediment	0.01		
Total Coe Length	1.52		
Total Sed Length	1.51		
Total Sed Mass		512.27	420.852
in situ length, ft	2.075		1.21
Area of in situ core, ft ²	0.045269		0.026398
in situ density, g/ft ³	11316.02		15942.52
	24.89525 lbs/ft ³		35.07355 lbs/ft ³

Core X Section			
G-23	Length, ft	Mass, g	- Flock
core water		49.418	
floc	0.3	107.721	
Sediment Top	0.47	164.583	
Sediment Bottom		123.888	
Sub Sediment	0		
Total Coe Length	0.77		
Total Sed Length	0.77		
Total Sed Mass		445.61	288.471
in situ length, ft	1.34		0.47
Area of in situ core, ft ²	0.029234		0.01025
in situ density, g/ft ³	15242.74		28133.1
	33.53403 lbs/ft ³		61.8928 lbs/ft ³

Core			
I-17	Length, ft	Mass, g	- Flock
core water		0	
floc	0.35	108.663	
Sediment Top	0.75	200.7	
Sediment Bottom		206.132	
Sub Sediment	0.04		
Total Coe Length	1.14		
Total Sed Length	1.1		
Total Sed Mass		515.495	406.832
in situ length, ft	1.59		0.75
Area of in situ core, ft ²	0.034688		0.016362
in situ density, g/ft ³	14860.74		24863.76
	32.69362 lbs/ft ³		54.70027 lbs/ft ³

Average Results			
in situ length, ft	2.06667	-Flock	0.77
Area of in situ core, ft ²	0.045088		0.0168
in situ density, g/ft ³	11002.2		20319.8
lb/ft	24.20484		37.907

TABLE XX

BULK DENSITY SUMMARY INFORMATION, PERRY 1 POND

Perry 1 (Complete)

Core X Section			
B1-A2			
	Length, ft	Mass, g	- Flock
core water		0	
floc	0.2	67.826	
Sediment Top	0.5	114.774	
Sediment Bottom		138.111	
Sub Sediment		0	
Total Coe Length	0.7		
Total Sed Length	0.7		
Total Sed Mass		320.711	252.885
in situ length, ft	1.3		0.5
Area of in situ core, ft ²	0.028362		0.01091
in situ density, g/ft ³	11307.94		23182.8
	24.87747 lbs/ft ³		51.0022 lbs/ft ³

Core X Section			
D-51			
	Length, ft	Mass, g	- Flock
core water		0	
floc	0.1	45.32	
Sediment Top	0.55	144.674	
Sediment Bottom		196.149	
Sub Sediment		0	
Total Coe Length	0.65		
Total Sed Length	0.65		
Total Sed Mass		386.143	340.823
in situ length, ft	2.4		0.55
Area of in situ core, ft ²	0.05236		0.011999
in situ density, g/ft ³	7374.794		28403.98
	16.22455 lbs/ft ³		62.48876 lbs/ft ³

Core X Section			
D-81			
	Length, ft	Mass, g	- Flock
core water		0	
floc	0.1	78.581	
Sediment Top	1	345.171	
Sediment Bottom		287.917	
Sub Sediment	0.02	0	
Total Coe Length	1.12		
Total Sed Length	1.1		
Total Sed Mass		711.669	633.088
in situ length, ft	2.06		1
Area of in situ core, ft ²	0.044942		0.02182
in situ density, g/ft ³	15835.21		29018.6
	34.83746 lbs/ft ³		63.841 lbs/ft ³

Core X Section			
G-36			
	Length, ft	Mass, g	- Flock
core water		0	
floc	0.1	50.362	
Sediment Top	0.4	117.054	
Sediment Bottom		118.727	
Sub Sediment		0	
Total Coe Length	0.5		
Total Sed Length	0.5		
Total Sed Mass		286.143	235.781
in situ length, ft	0.86		0.4
Area of in situ core, ft ²	0.018762		0.008727
in situ density, g/ft ³	15250.98		27018.54
	33.55215 lbs/ft ³		59.44078 lbs/ft ³

Core X Section			
G-66			
	Length, ft	Mass, g	- Flock
core water		35.289	
floc	0.3	42.989	
Sediment Top	0.4	138.506	
Sediment Bottom		177.29	
Sub Sediment	0.01	0	
Total Coe Length	0.71		
Total Sed Length	0.7		
Total Sed Mass		394.074	315.796
in situ length, ft	1.17		0.4
Area of in situ core, ft ²	0.025525		0.00873
in situ density, g/ft ³	15438.49		36187.6
	33.96468 lbs/ft ³		79.6127 lbs/ft ³

Core X Section			
K-40			
	Length, ft	Mass, g	- Flock
core water		82.727	
floc	0.1	0	
Sediment Top	0.2	190.976	
Sediment Bottom		0	
Sub Sediment		0	
Total Coe Length	0.3		
Total Sed Length	0.3		
Total Sed Mass		273.703	190.976
in situ length, ft	2.61		0.2
Area of in situ core, ft ²	0.056941		0.004363
in situ density, g/ft ³	4806.756		43768.51
	10.57486 lbs/ft ³		96.29073 lbs/ft ³

Core X Section			
K-60			
	Length, ft	Mass, g	- Flock
core water		61.583	
floc	0.1	61.284	
Sediment Top	0.35	45.83	
Sediment Bottom		88.949	
Sub Sediment	0.02	0	
Total Coe Length	0.47		
Total Sed Length	0.45		
Total Sed Mass		257.646	134.779
in situ length, ft	2.35		0.35
Area of in situ core, ft ²	0.051269		0.00764
in situ density, g/ft ³	5025.376		17650.9
	11.05583 lbs/ft ³		38.832 lbs/ft ³

Core X Section			
N1-M2			
	Length, ft	Mass, g	- Flock
core water		95.207	
floc	0.3	63.498	
Sediment Top	0.4	175.652	
Sediment Bottom		0	
Sub Sediment		0	
Total Coe Length	0.7		
Total Sed Length	0.7		
Total Sed Mass		334.357	175.652
in situ length, ft	2.54		0.4
Area of in situ core, ft ²	0.055414		0.008727
in situ density, g/ft ³	6033.783		20128.25
	13.27432 lbs/ft ³		44.28216 lbs/ft ³

Average Results

in situ length, ft	1.91125	-Flock	0.49286
Area of in situ core, ft ²	0.041697		0.01075
in situ density, g/ft ³	10134.17		29672.6
lb/ft	22.29517		59.1932

TABLE XXI

BULK DENSITY SUMMARY INFORMATION, PERRY 2 POND

Perry 2 (Complete)

Core X Section

B-46	Length, ft	Mass, g	- Flock
core water		64.009	
floc	0.42	99.439	
Sediment Top	0.65	234.887	
Sediment Bottom		407.935	
Sub Sediment	0.01	7.304	
Total Coe Length	1.08		
Total Sed Length	1.07		
Total Sed Mass		806.27	642.822

in situ length, ft	1.88	0.65
Area of in situ core, ft ²	0.041015	0.01418
in situ density, g/ft ³	19657.83	45330.5
	43.24723 lbs/ft ³	99.7271 lbs/ft ³

Core X Section

C-30	Length, ft	Mass, g	- Flock
core water		39.787	
floc	0.3	89.105	
Sediment Top	1.1	126.089	
Sediment Bottom		107.126	
Sub Sediment	0.02	45.88	
Total Coe Length	1.42		
Total Sed Length	1.4		
Total Sed Mass		362.107	233.215

in situ length, ft	3.56	1.1
Area of in situ core, ft ²	0.077667	0.023998
in situ density, g/ft ³	4662.297	9717.997
	10.25705 lbs/ft ³	21.37959 lbs/ft ³

Core X Section

D-30	Length, ft	Mass, g	- Flock
core water		26.202	
floc	0.3	69.458	
Sediment Top	0.9	62.942	
Sediment Bottom		172.105	
Sub Sediment		0	
Total Coe Length	1.2		
Total Sed Length	1.2		
Total Sed Mass		330.707	235.047

in situ length, ft	2.32	0.9
Area of in situ core, ft ²	0.050615	0.01963
in situ density, g/ft ³	6533.838	11970.9
	14.37444 lbs/ft ³	26.3359 lbs/ft ³

Average Results			
in situ length, ft	1.902	-Flock	0.883333
Area of in situ core, ft ²	0.041495		0.019271
in situ density, g/ft ³	17180.49		22339.78
lb/ft	37.79708		49.14751

APPENDIX II. SOILS DATA FOR EACH SITE (NRCS 2008).

Soil Map—Anderson and Franklin Counties, Kentucky
(Hickory Ridge Rd)

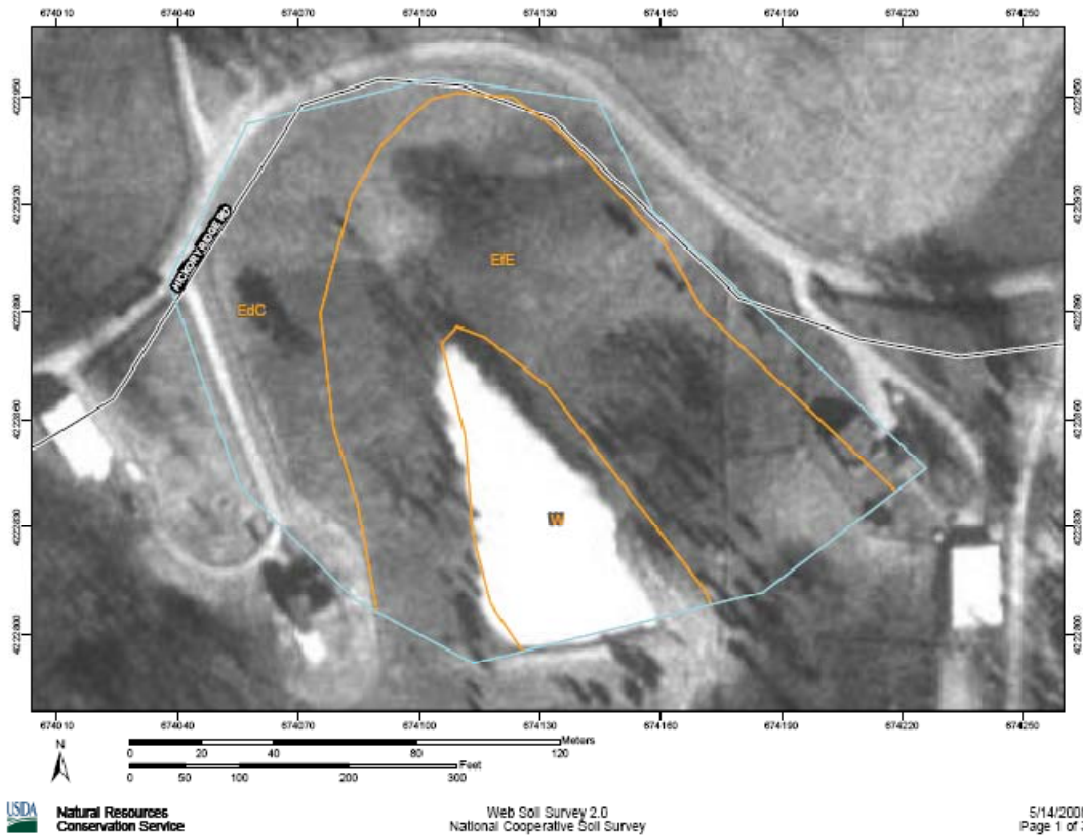

Soil Map—Anderson and Franklin Counties, Kentucky

Hickory Ridge Rd

Map Unit Legend

Anderson and Franklin Counties, Kentucky (KY601)			
Map Unit Symbol	Map Unit Name	Acres In AOI	Percent of AOI
EdC	Eden silty clay loam, 6 to 15 percent slopes	1.5	28.3%
EeE	Eden flaggy silty clay, 15 to 35 percent slopes	3.1	56.2%
W	Water	0.8	15.5%
Totals for Area of Interest (AOI)		5.4	100.0%

FIGURE 34 - Soils map of Hickory Grove site.

Soil Map—Anderson and Franklin Counties, Kentucky
(Sullivan Pond)

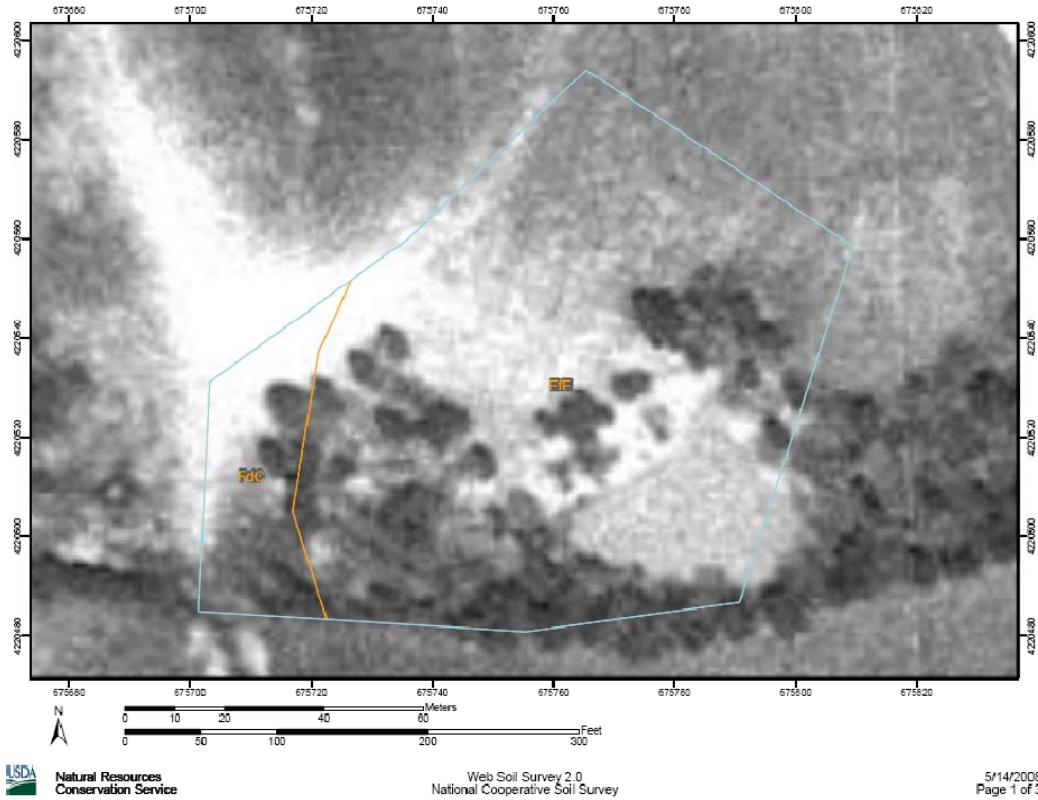

Soil Map—Anderson and Franklin Counties, Kentucky

Sullivan Pond

Map Unit Legend

Anderson and Franklin Counties, Kentucky (KY601)			
Map Unit Symbol	Map Unit Name	Acres in AOI	Percent of AOI
EfE	Eden flaggy silty clay, 15 to 35 percent slopes	2.2	88.3%
FdC	Faywood silt loam, 6 to 12 percent slopes	0.3	11.5%
Totals for Area of Interest (AOI)		2.5	100.0%

FIGURE 35 - Soils map of Sullivan site.

Soil Map—Anderson and Franklin Counties, Kentucky
(Crawford Pond)

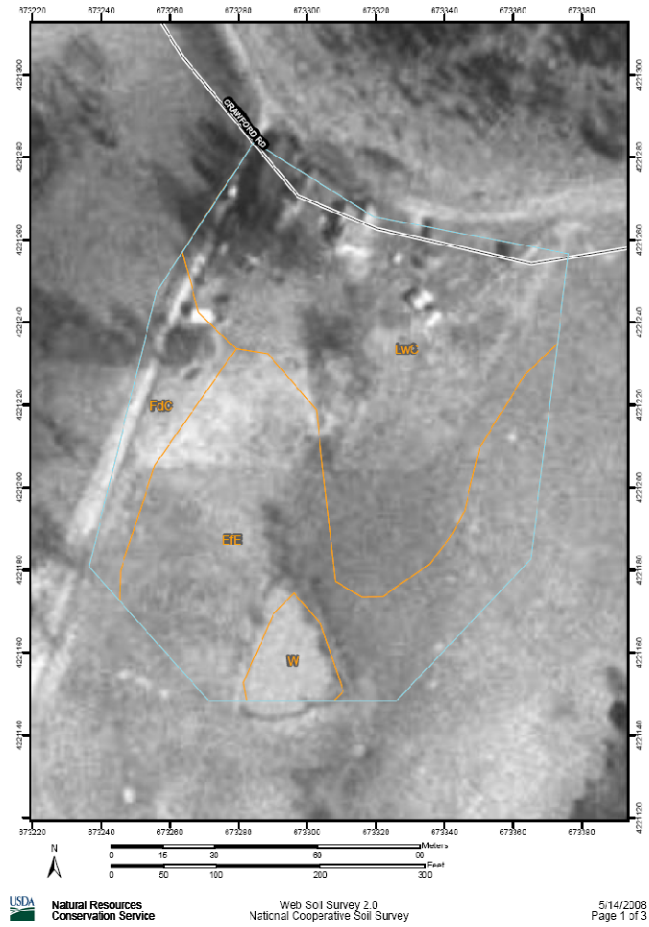

Soil Map—Anderson and Franklin Counties, Kentucky

Crawford Pond

Map Unit Legend

Anderson and Franklin Counties, Kentucky (KY601)			
Map Unit Symbol	Map Unit Name	Acres in AOI	Percent of AOI
Efe	Eden flaggy silty clay, 15 to 35 percent slopes	1.6	40.6%
FdC	Faywood silt loam, 6 to 12 percent slopes	0.3	8.6%
LwC	Lowell silt loam, 6 to 12 percent slopes	1.9	47.2%
W	Water	0.1	3.7%
Totals for Area of Interest (AOI)		4.0	100.0%

FIGURE 36 - Soils Map of Crawford site.

Soil Map—Anderson and Franklin Counties, Kentucky, and Shelby County, Kentucky
(Wilson 1 and 2)

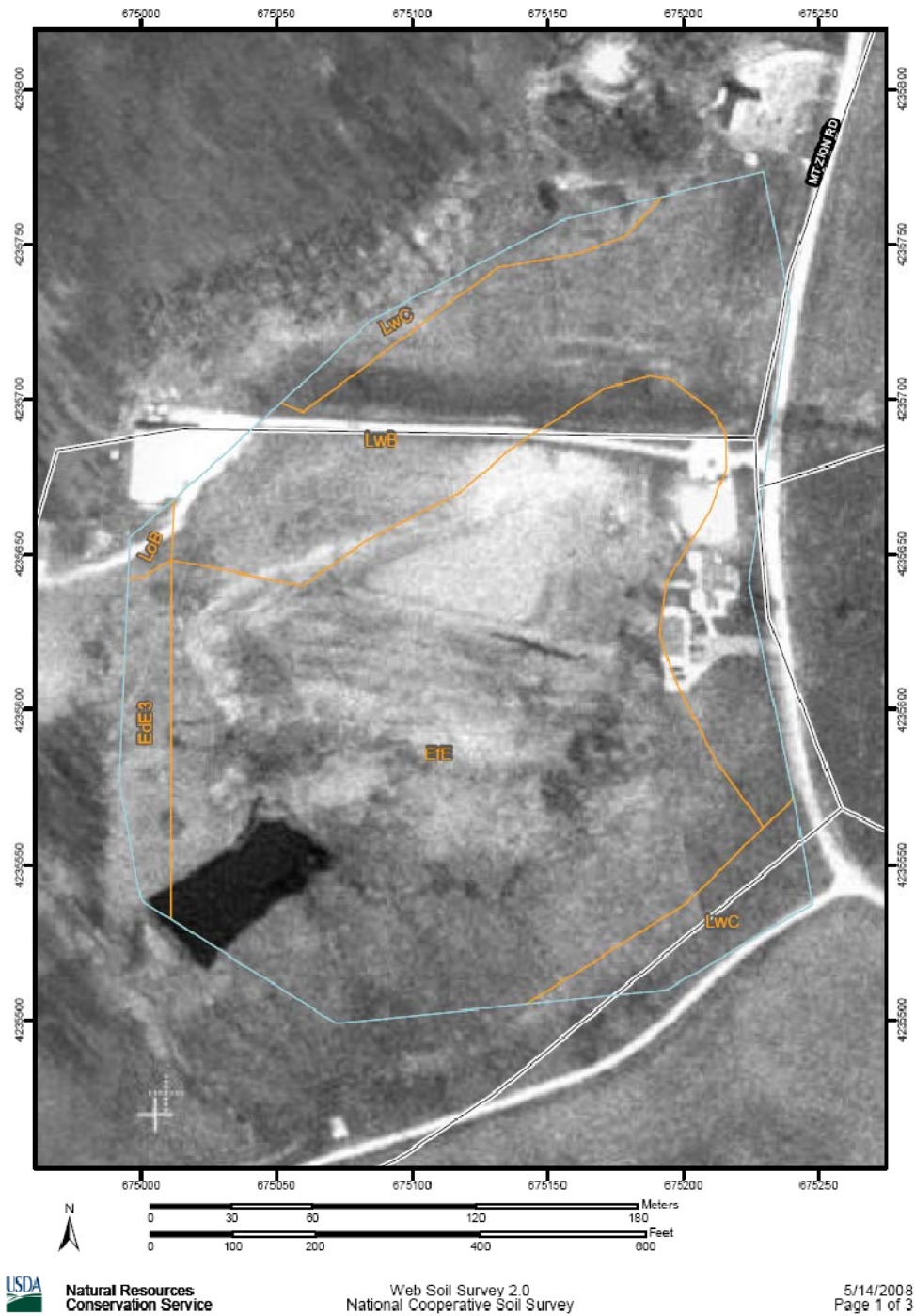

FIGURE 37 (a) - Soils map for sites Wilson 1 and 2.

Map Unit Legend

Anderson and Franklin Counties, Kentucky (KY601)			
Map Unit Symbol	Map Unit Name	Acres in AOI	Percent of AOI
EfE	Eden flaggy silty clay, 15 to 35 percent slopes	8.8	59.3%
LwB	Lowell silt loam, 2 to 6 percent slopes	4.5	30.3%
LwC	Lowell silt loam, 6 to 12 percent slopes	1.0	6.5%
Shelby County, Kentucky (KY211)			
Map Unit Symbol	Map Unit Name	Acres in AOI	Percent of AOI
EdE3	Eden flaggy silty clay, 20 to 30 percent slopes, severely eroded	0.5	3.4%
LoB	Lowell silt loam, 2 to 6 percent slopes	0.1	0.5%
Totals for Area of Interest (AOI)		14.8	100.0%

FIGURE 37 (b) - Legend for Wilson 1 and 2 soils map.

Soil Map—Anderson and Franklin Counties, Kentucky
(Gunn Pond)

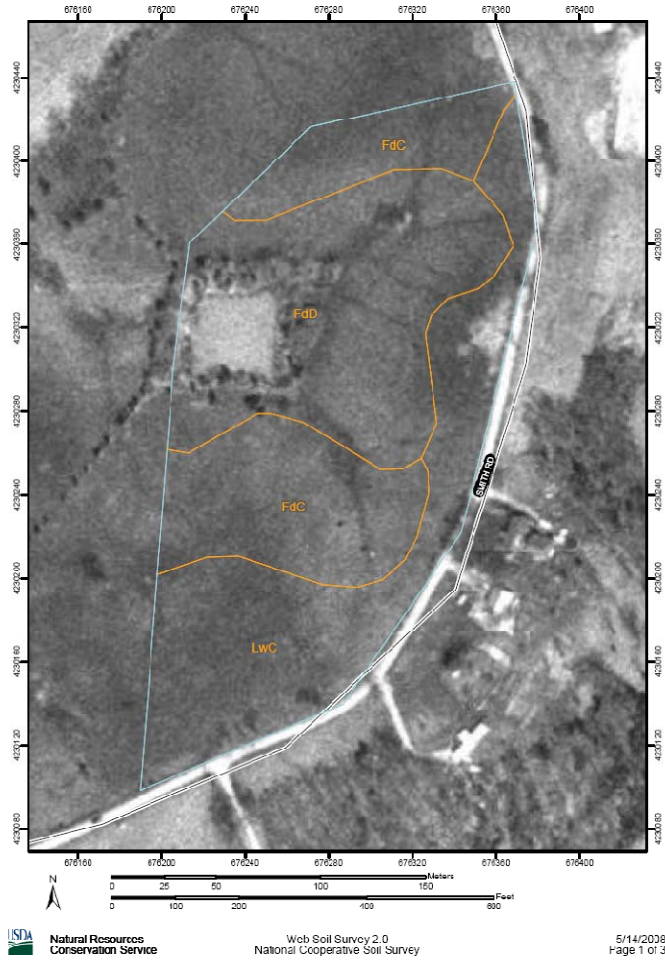

Soil Map—Anderson and Franklin Counties, Kentucky

Gunn Pond

Map Unit Legend

Anderson and Franklin Counties, Kentucky (KY601)			
Map Unit Symbol	Map Unit Name	Acres in AOI	Percent of AOI
FdC	Faywood silt loam, 6 to 12 percent slopes	2.9	28.0%
FdD	Faywood silt loam, 12 to 30 percent slopes	3.9	37.8%
LwC	Lowell silt loam, 6 to 12 percent slopes	3.5	34.3%
Totals for Area of Interest (AOI)		10.3	100.0%

FIGURE 38 - Soils map for Gunn site.

Soil Map—Anderson and Franklin Counties, Kentucky
(McDevitt Pond)

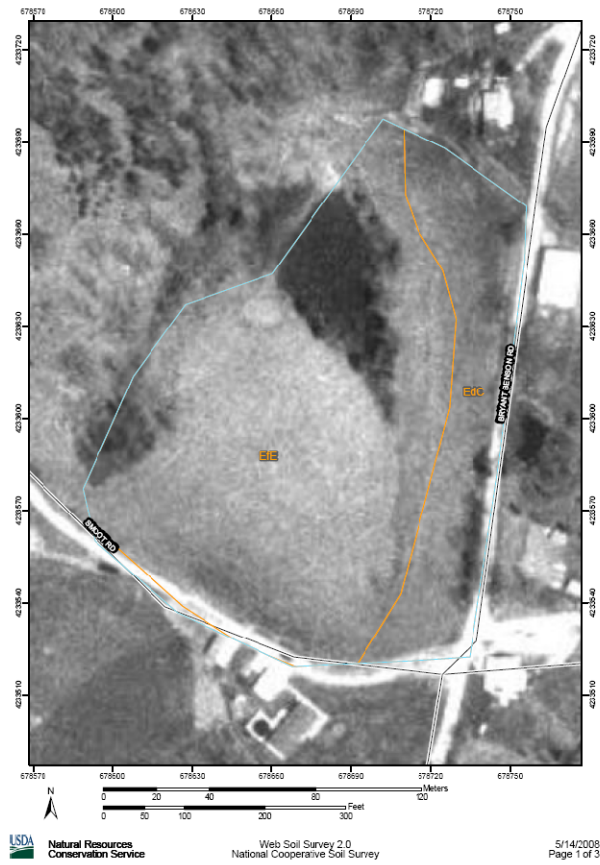

Soil Map—Anderson and Franklin Counties, Kentucky

McDevitt Pond

Map Unit Legend

Anderson and Franklin Counties, Kentucky (KY601)			
Map Unit Symbol	Map Unit Name	Acres in AOI	Percent of AOI
EdC	Eden silty clay loam, 6 to 15 percent slopes	1.4	24.9%
EFe	Eden flaggy silty clay, 15 to 35 percent slopes	4.3	75.1%
Totals for Area of Interest (AOI)		5.7	100.0%

FIGURE 39 - Soils map for McDevitte Site.

Soil Map--Anderson and Franklin Counties, Kentucky
(Perry 1)

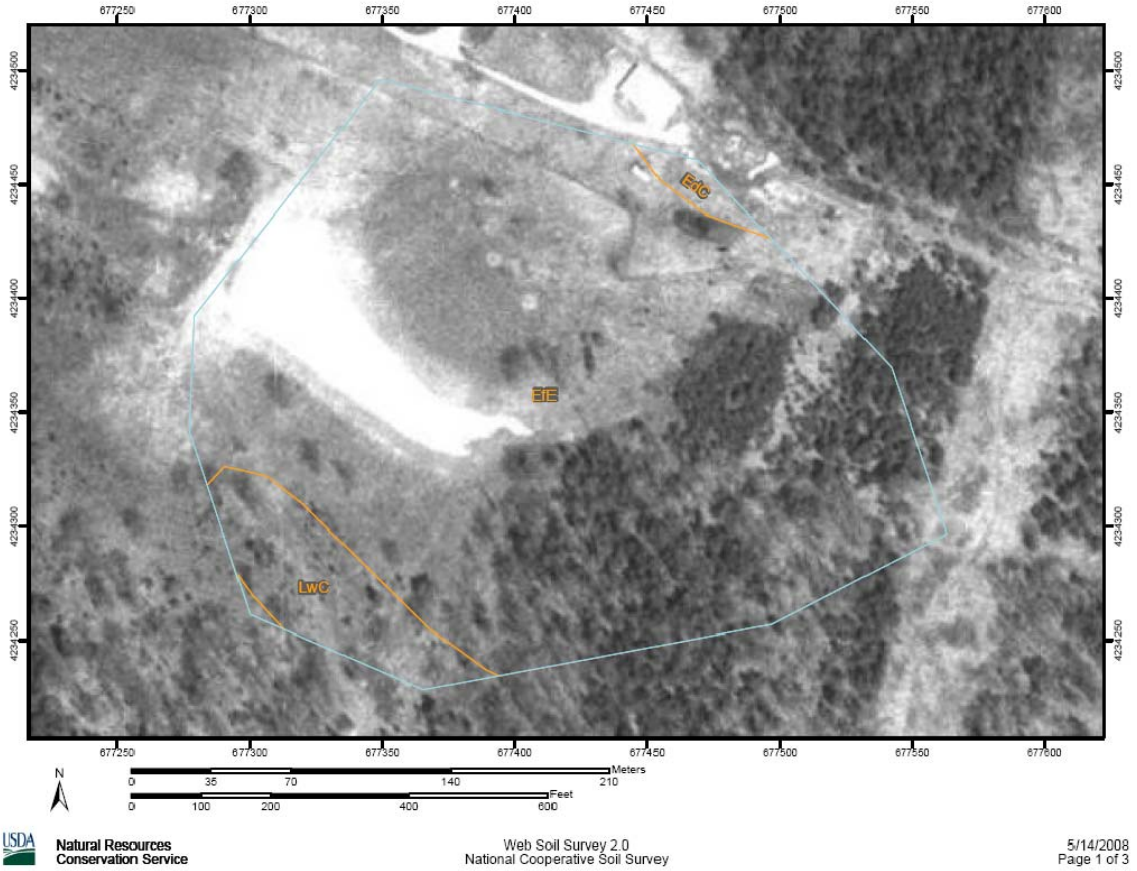

Soil Map--Anderson and Franklin Counties, Kentucky

Perry 1

Map Unit Legend

Anderson and Franklin Counties, Kentucky (KY601)			
Map Unit Symbol	Map Unit Name	Acres in AOI	Percent of AOI
EdC	Eden silty clay loam, 6 to 15 percent slopes	0.2	1.2%
FIF	Eden flaggy silty clay, 15 to 35 percent slopes	14.0	91.2%
LwC	Lowell silt loam, 6 to 12 percent slopes	1.2	7.7%
Totals for Area of Interest (AOI)		15.4	100.0%

FIGURE 40 - Soils map for Perry 1 site.

Soil Map--Anderson and Franklin Counties, Kentucky
(Perry2)

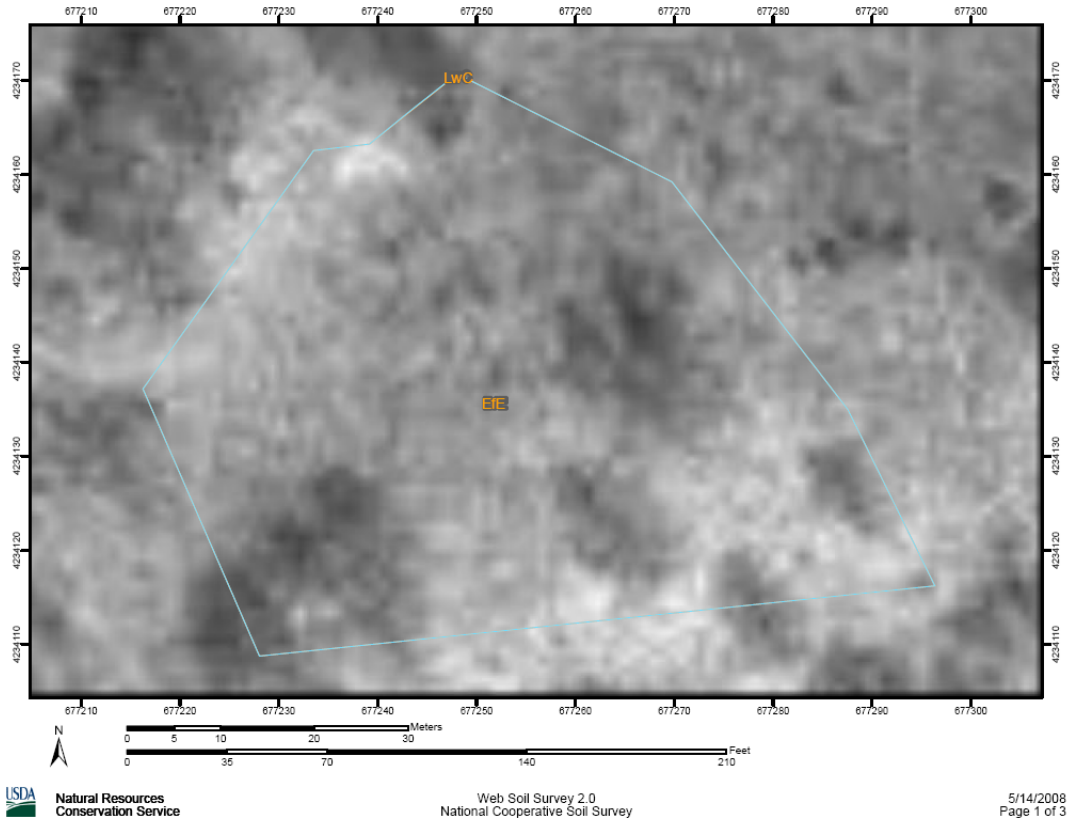

Soil Map--Anderson and Franklin Counties, Kentucky

Perry2

Map Unit Legend

Anderson and Franklin Counties, Kentucky (KY601)			
Map Unit Symbol	Map Unit Name	Acres in AOI	Percent of AOI
EFe	Eden flaggy silty clay, 15 to 35 percent slopes	0.8	100.0%
LwC	Lowell silt loam, 6 to 12 percent slopes	0.0	0.0%
Totals for Area of Interest (AOI)		0.8	100.0%

FIGURE 41 - Soils map for Perry 2 site.

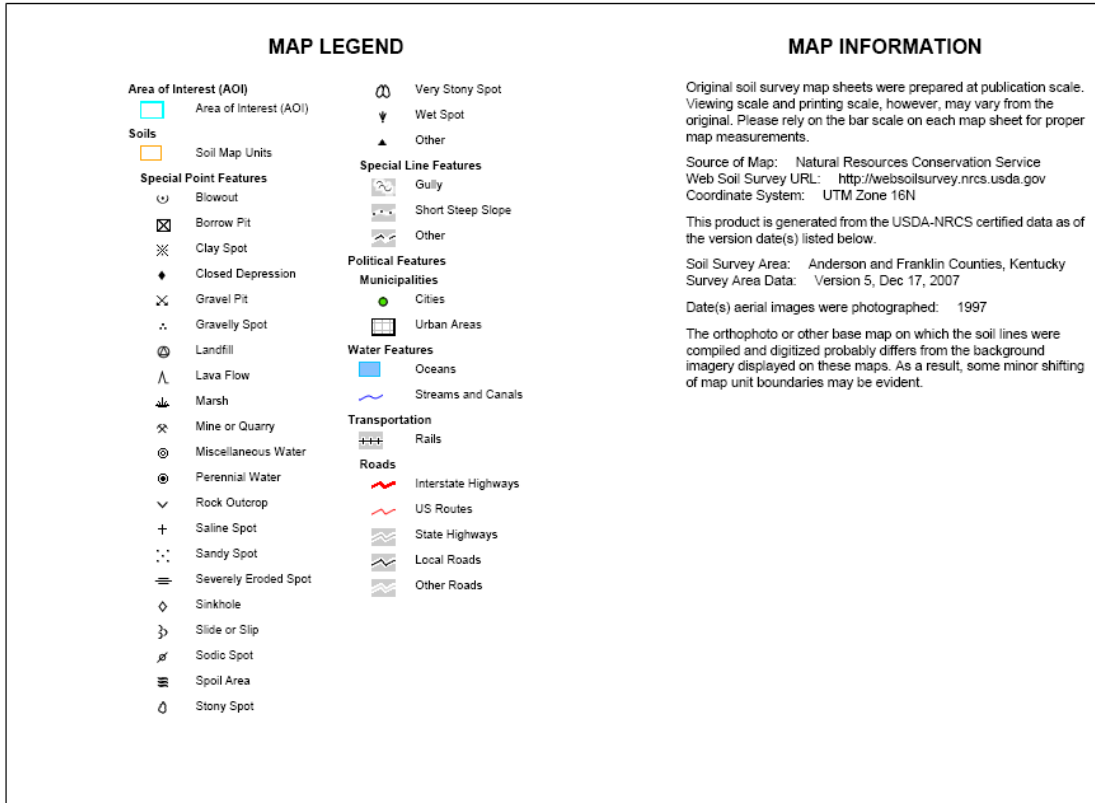

FIGURE 42 - Legend for soils maps, all sites.

Soil Summary Soil Information (NRCS 2008)

Anderson and Franklin Counties, Kentucky Version

EdC—Eden silty clay loam, 6 to 15 percent slopes

Map Unit Setting

- Mean annual precipitation: 37 to 49 inches
- Mean annual air temperature: 42 to 66 degrees F
- Frost-free period: 163 to 200 days

Map Unit Composition

- Eden and similar soils: 85 percent
- Minor components: 15 percent

Description of Eden

Setting

- Landform: Ridges
- Landform position (two-dimensional): Shoulder
- Landform position (three-dimensional): Side slope
- Down-slope shape: Convex
- Across-slope shape: Linear
- Parent material: Clayey residuum weathered from calcareous shale and/or limestone and siltstone

Properties and qualities

- Slope: 6 to 15 percent
- Depth to restrictive feature: 20 to 40 inches to paralithic bedrock
- Drainage class: Well drained
- Capacity of the most limiting layer to transmit water (Ksat): Moderately low to moderately high (0.06 to 0.20 in/hr)
- Depth to water table: More than 80 inches
- Frequency of flooding: None
- Frequency of ponding: None
- Calcium carbonate, maximum content: 14 percent
- Available water capacity: Very low (about 2.7 inches)

Interpretive groups

- Land capability (nonirrigated): 3e

Typical profile

- 0 to 5 inches: Silty clay loam
- 5 to 23 inches: Flaggy silty clay
- 23 to 67 inches: Weathered bedrock

Minor Components

Lowell

- Percent of map unit: 5 percent

Fairmount

- Percent of map unit: 5 percent

Faywood

- Percent of map unit: 5 percent

EfE—Eden flaggy silty clay, 15 to 35 percent slopes

Map Unit Setting

- Mean annual precipitation: 37 to 49 inches
- Mean annual air temperature: 42 to 66 degrees F
- Frost-free period: 163 to 200 days

Map Unit Composition

- Eden and similar soils: 75 percent
- Minor components: 25 percent

Description of Eden

Setting

- Landform: Hills
- Landform position (two-dimensional): Backslope
- Landform position (three-dimensional): Side slope
- Down-slope shape: Convex
- Across-slope shape: Linear
- Parent material: Clayey residuum weathered from calcareous shale and/or limestone and siltstone

Properties and qualities

- Slope: 15 to 35 percent
- Depth to restrictive feature: 20 to 40 inches to paralithic bedrock
- Drainage class: Well drained
- Capacity of the most limiting layer to transmit water (Ksat): Moderately low to moderately high (0.06 to 0.20 in/hr)
- Depth to water table: More than 80 inches
- Frequency of flooding: None
- Frequency of ponding: None
- Calcium carbonate, maximum content: 14 percent
- Available water capacity: Very low (about 2.7 inches)

Interpretive groups

- Land capability (nonirrigated): 6e

Typical profile

- 0 to 5 inches: Flaggy silty clay
- 5 to 23 inches: Flaggy silty clay
- 23 to 67 inches: Weathered bedrock

Minor Components

Faywood

- Percent of map unit: 9 percent

Boonesboro

- Percent of map unit: 8 percent

Fairmount

- Percent of map unit: 8 percent

LwB—Lowell silt loam, 2 to 6 percent slopes

Map Unit Setting

- Elevation: 500 to 1,400 feet
- Mean annual precipitation: 37 to 49 inches
- Mean annual air temperature: 42 to 66 degrees F
- Frost-free period: 163 to 200 days

Map Unit Composition

- Lowell and similar soils: 90 percent
- Minor components: 10 percent

Description of Lowell

Setting

- Landform: Ridges
- Landform position (two-dimensional): Summit
- Landform position (three-dimensional): Interfluve
- Down-slope shape: Convex
- Across-slope shape: Linear
- Parent material: Clayey residuum weathered from limestone and/or calcareous shale and/or calcareous siltstone

Properties and qualities

- Slope: 2 to 6 percent
- Depth to restrictive feature: 40 to 60 inches to lithic bedrock
- Drainage class: Well drained
- Capacity of the most limiting layer to transmit water (Ksat): Moderately high (0.20 to 0.57 in/hr)
- Depth to water table: More than 80 inches
- Frequency of flooding: None
- Frequency of ponding: None
- Calcium carbonate, maximum content: 3 percent
- Available water capacity: High (about 9.0 inches)

Interpretive groups

- Land capability (nonirrigated): 2e

Typical profile

- 0 to 7 inches: Silt loam
- 7 to 12 inches: Silty clay loam
- 12 to 57 inches: Clay
- 57 to 61 inches: Unweathered bedrock

Minor Components

Faywood

- Percent of map unit: 4 percent

Maury

- Percent of map unit: 3 percent

Nicholson

- Percent of map unit: 3 percent

LwC—Lowell silt loam, 6 to 12 percent slopes

Map Unit Setting

- Elevation: 500 to 1,400 feet
- Mean annual precipitation: 37 to 49 inches
- Mean annual air temperature: 42 to 66 degrees F
- Frost-free period: 163 to 200 days

Map Unit Composition

- Lowell and similar soils: 85 percent
- Minor components: 15 percent

Description of Lowell

Setting

- Landform: Ridges
- Landform position (two-dimensional): Shoulder
- Landform position (three-dimensional): Side slope
- Down-slope shape: Convex
- Across-slope shape: Linear
- Parent material: Clayey residuum weathered from limestone and/or calcareous shale and/or calcareous siltstone

Properties and qualities

- Slope: 6 to 12 percent
- Depth to restrictive feature: 40 to 60 inches to lithic bedrock
- Drainage class: Well drained
- Capacity of the most limiting layer to transmit water (Ksat): Moderately high (0.20 to 0.57 in/hr)
- Depth to water table: More than 80 inches
- Frequency of flooding: None
- Frequency of ponding: None
- Calcium carbonate, maximum content: 3 percent
- Available water capacity: High (about 9.0 inches)

Interpretive groups

- Land capability (nonirrigated): 3e

Typical profile

- 0 to 7 inches: Silt loam
- 7 to 12 inches: Silty clay loam
- 12 to 57 inches: Clay
- 57 to 61 inches: Unweathered bedrock

Minor Components

Nicholson

- Percent of map unit: 5 percent

Faywood

- Percent of map unit: 5 percent

Maury

- Percent of map unit: 5 percent

FdC—Faywood silt loam, 6 to 12 percent slopes

Map Unit Setting

- Mean annual precipitation: 37 to 49 inches
- Mean annual air temperature: 42 to 66 degrees F
- Frost-free period: 163 to 200 days

Map Unit Composition

- Faywood and similar soils: 85 percent
- Minor components: 15 percent

Description of Faywood

Setting

- Landform: Ridges
- Landform position (two-dimensional): Shoulder
- Landform position (three-dimensional): Side slope
- Down-slope shape: Convex
- Across-slope shape: Linear
- Parent material: Clayey residuum weathered from limestone and shale

Properties and qualities

- Slope: 6 to 12 percent
- Depth to restrictive feature: 20 to 40 inches to lithic bedrock
- Drainage class: Well drained
- Capacity of the most limiting layer to transmit water (Ksat): Moderately low to moderately high (0.06 to 0.57 in/hr)
- Depth to water table: More than 80 inches
- Frequency of flooding: None
- Frequency of ponding: None
- Available water capacity: Low (about 5.3 inches)

Interpretive groups

- Land capability (nonirrigated): 3e

Typical profile

- 0 to 5 inches: Silt loam
- 5 to 34 inches: Silty clay
- 34 to 38 inches: Unweathered bedrock

Minor Components

Eden

- Percent of map unit: 4 percent

Mcafee

- Percent of map unit: 4 percent

Lowell

- Percent of map unit: 4 percent

Fairmount

- Percent of map unit: 3 percent

FdD—Faywood silt loam, 12 to 30 percent slopes

Map Unit Setting

- Mean annual precipitation: 37 to 49 inches
- Mean annual air temperature: 42 to 66 degrees F
- Frost-free period: 163 to 200 days

Map Unit Composition

- Faywood and similar soils: 80 percent
- Minor components: 15 percent

Description of Faywood

Setting

- Landform: Hills
- Landform position (two-dimensional): Backslope
- Landform position (three-dimensional): Side slope
- Down-slope shape: Convex
- Across-slope shape: Linear
- Parent material: Clayey residuum weathered from limestone and shale

Properties and qualities

- Slope: 12 to 30 percent
- Depth to restrictive feature: 20 to 40 inches to lithic bedrock
- Drainage class: Well drained
- Capacity of the most limiting layer to transmit water (Ksat): Moderately low to moderately high (0.06 to 0.57 in/hr)
- Depth to water table: More than 80 inches
- Frequency of flooding: None
- Frequency of ponding: None
- Available water capacity: Low (about 5.3 inches)

Interpretive groups

- Land capability (nonirrigated): 6e

Typical profile

- 0 to 5 inches: Silt loam
- 5 to 34 inches: Silty clay
- 34 to 38 inches: Unweathered bedrock

Minor Components

Eden

- Percent of map unit: 5 percent

Fairmount

- Percent of map unit: 5 percent

Mcafee

- Percent of map unit: 5 percent

Shelby County, Kentucky Version

EdE3—Eden flaggy silty clay, 20 to 30 percent slopes, severely eroded

Map Unit Setting

- Elevation: 600 to 1,180 feet
- Mean annual precipitation: 41 to 54 inches
- Mean annual air temperature: 40 to 65 degrees F
- Frost-free period: 135 to 188 days

Map Unit Composition

- Eden and similar soils: 80 percent
- Minor components: 20 percent

Description of Eden

Setting

- Landform: Hills
- Landform position (two-dimensional): Backslope
- Landform position (three-dimensional): Side slope
- Down-slope shape: Convex
- Across-slope shape: Linear
- Parent material: Clayey residuum weathered from shale and siltstone and/or limestone

Properties and qualities

- Slope: 20 to 30 percent
- Depth to restrictive feature: 20 to 40 inches to paralithic bedrock
- Drainage class: Well drained
- Capacity of the most limiting layer to transmit water (Ksat): Moderately low to moderately high (0.06 to 0.20 in/hr)
- Depth to water table: More than 80 inches
- Frequency of flooding: None
- Frequency of ponding: None
- Calcium carbonate, maximum content: 14 percent
- Available water capacity: Very low (about 2.9 inches)

Interpretive groups

- Land capability (nonirrigated): 7e

Typical profile

- 0 to 6 inches: Flaggy silty clay
- 6 to 25 inches: Flaggy silty clay
- 25 to 29 inches: Weathered bedrock

Minor Components

Other soils

- Percent of map unit: 5 percent

Fairmount

- Percent of map unit: 5 percent

Faywood

- Percent of map unit: 5 percent

Lowell

- Percent of map unit: 5 percent

LoB—Lowell silt loam, 2 to 6 percent slopes

Map Unit Setting

- Elevation: 600 to 1,180 feet
- Mean annual precipitation: 41 to 54 inches
- Mean annual air temperature: 40 to 65 degrees F
- Frost-free period: 135 to 188 days

Map Unit Composition

- Lowell and similar soils: 90 percent
- Minor components: 10 percent

Description of Lowell

Setting

- Landform: Ridges
- Landform position (two-dimensional): Summit
- Landform position (three-dimensional): Interfluve
- Down-slope shape: Convex
- Across-slope shape: Linear
- Parent material: Clayey residuum weathered from limestone and shale

Properties and qualities

- Slope: 2 to 6 percent
- Depth to restrictive feature: 40 to 60 inches to lithic bedrock
- Drainage class: Well drained
- Capacity of the most limiting layer to transmit water (Ksat): Moderately high (0.20 to 0.57 in/hr)
- Depth to water table: More than 80 inches
- Frequency of flooding: None
- Frequency of ponding: None
- Calcium carbonate, maximum content: 3 percent
- Available water capacity: Moderate (about 8.2 inches)

Interpretive groups

- Land capability (nonirrigated): 2e

Typical profile

- 0 to 8 inches: Silt loam
- 8 to 28 inches: Silty clay
- 28 to 50 inches: Clay
- 50 to 54 inches: Unweathered bedrock

Minor Components

Shelbyville

- Percent of map unit: 2 percent

Nicholson

- Percent of map unit: 2 percent

Beasley

- Percent of map unit: 2 percent

Faywood

- Percent of map unit: 2 percent

Other soils

- Percent of map unit: 2 percent

APPENDIX III. DETAILS OF SITE LAYOUTS AND BATHYMETRIC SURVEYS

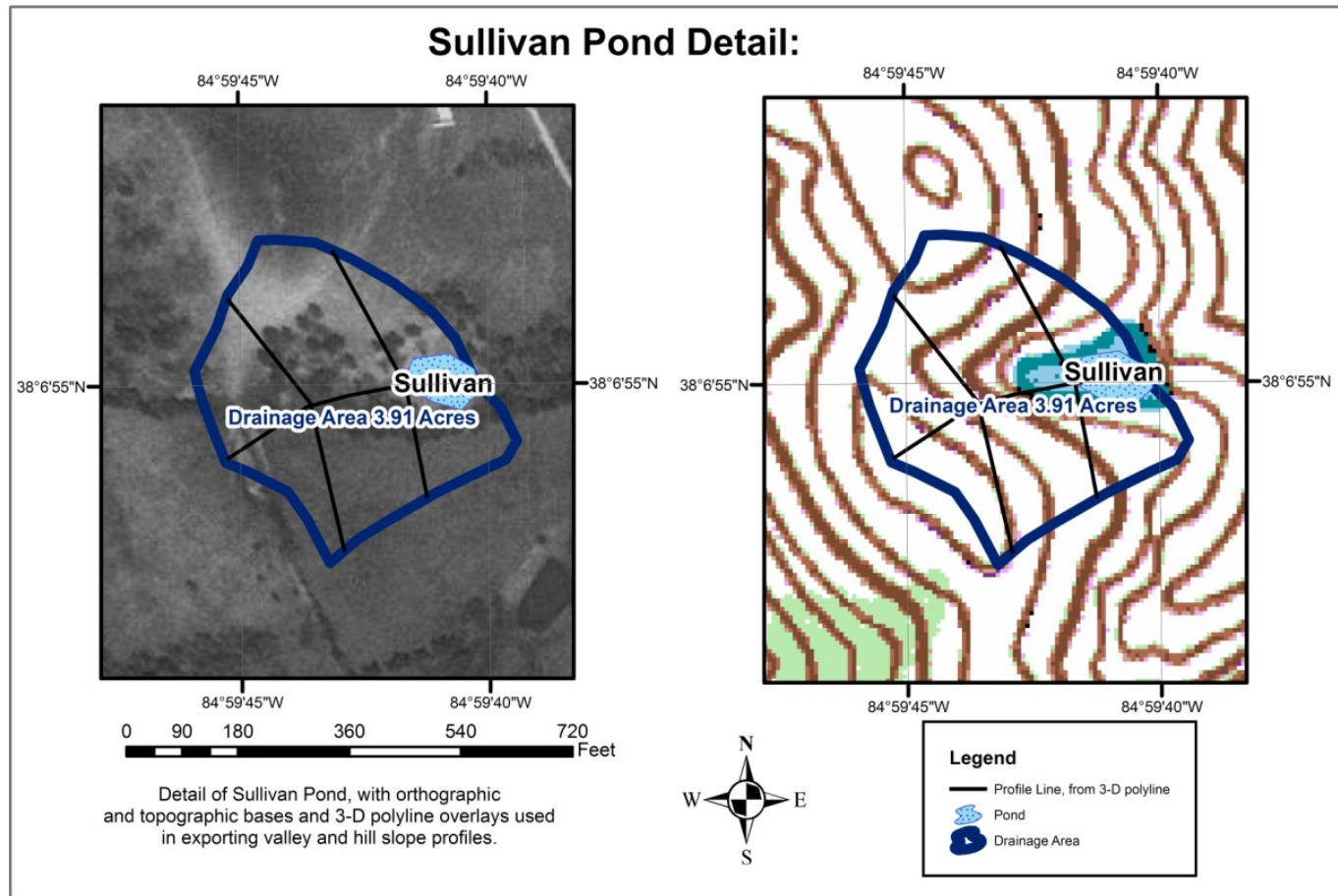

FIGURE 43 - Orthographic and topographic layout of Sullivan pond site.

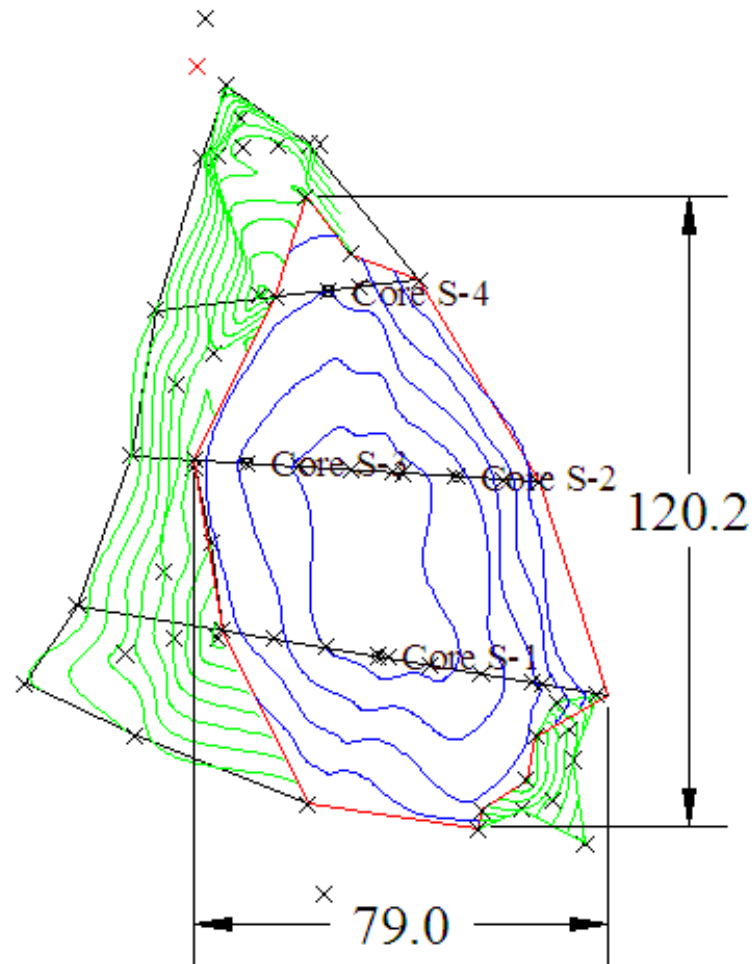

FIGURE 44 - AutoCAD layout of Sullivan site showing pond (red), sediment toe (black), bathymetric survey points, and core locations, bottom of pond sediment represented by blue contours, bottom of sediment toe sediment represented by green contours, dimensions in feet.

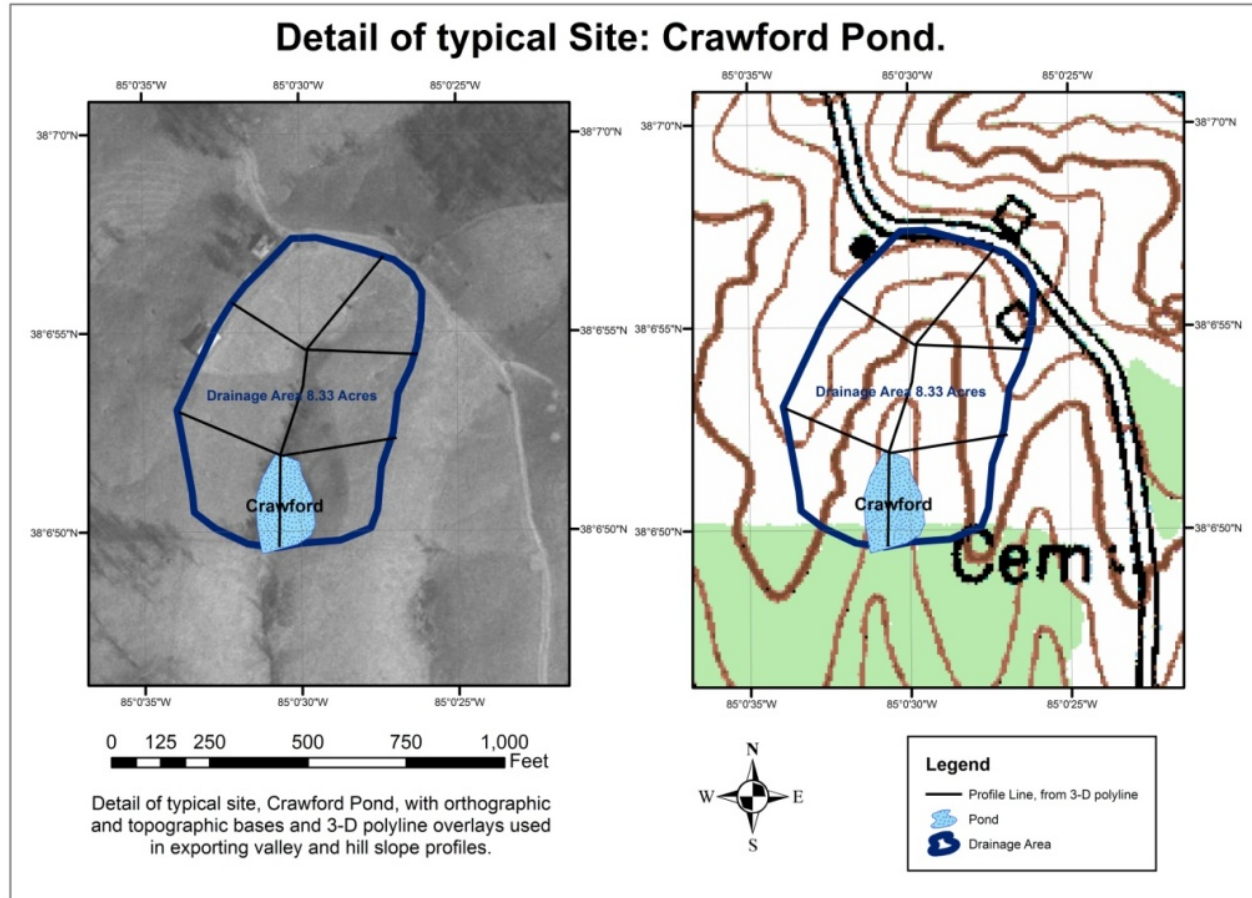

FIGURE 45 - Orthographic and topographic layout of Crawford pond site.

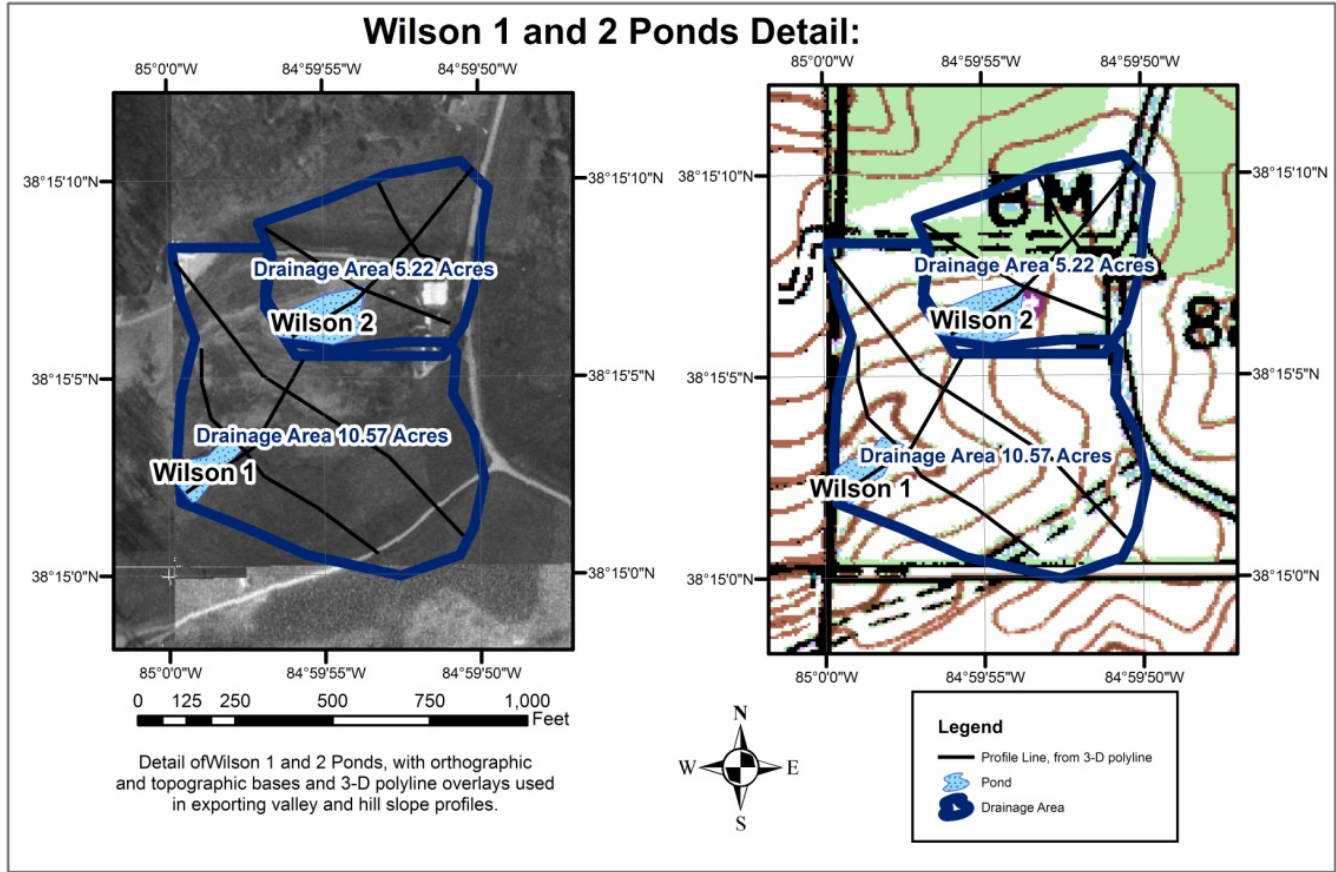

FIGURE 47 - Orthographic and topographic layout of Wilson 1 and Wilson 2 pond sites.

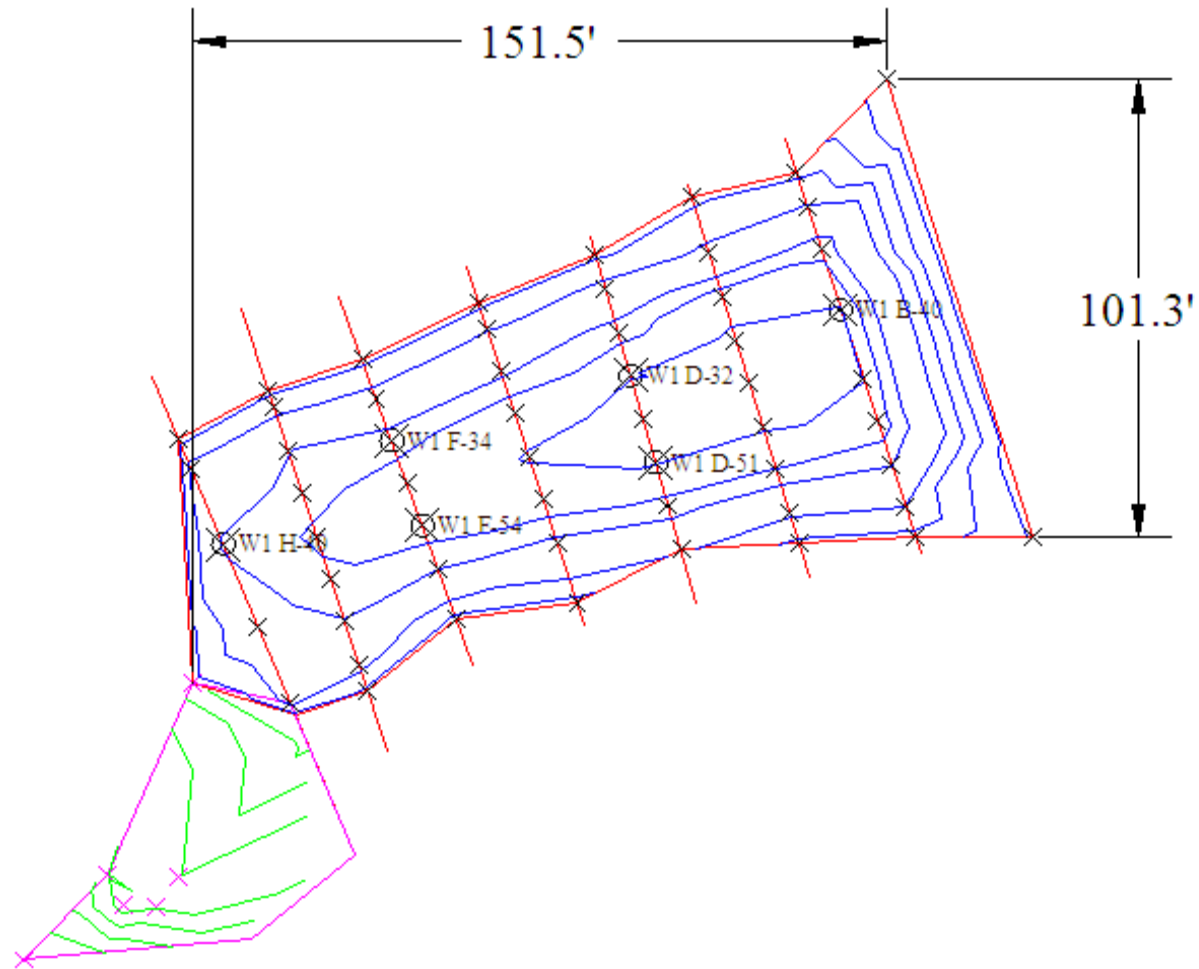

FIGURE 48 - AutoCAD layout of Wilson1 site showing pond (red outline), sediment toe (purple outline), bathymetric survey points, and core locations, contours represent pond sediment bottom, dimensions in feet.

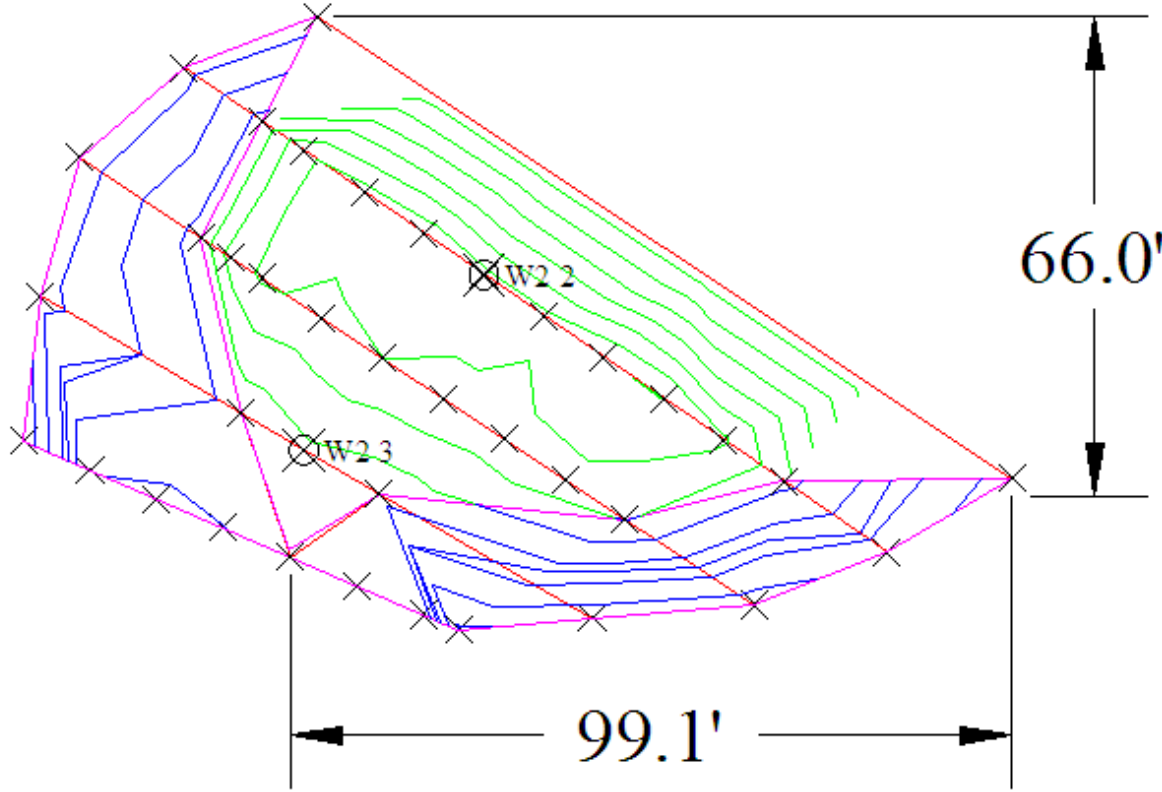

FIGURE 49 - AutoCAD layout of Wilson2 site showing pond (red outline), sediment toe (purple outline), bathymetric survey points, and core locations, contours represent pond sediment bottom, dimensions in feet.

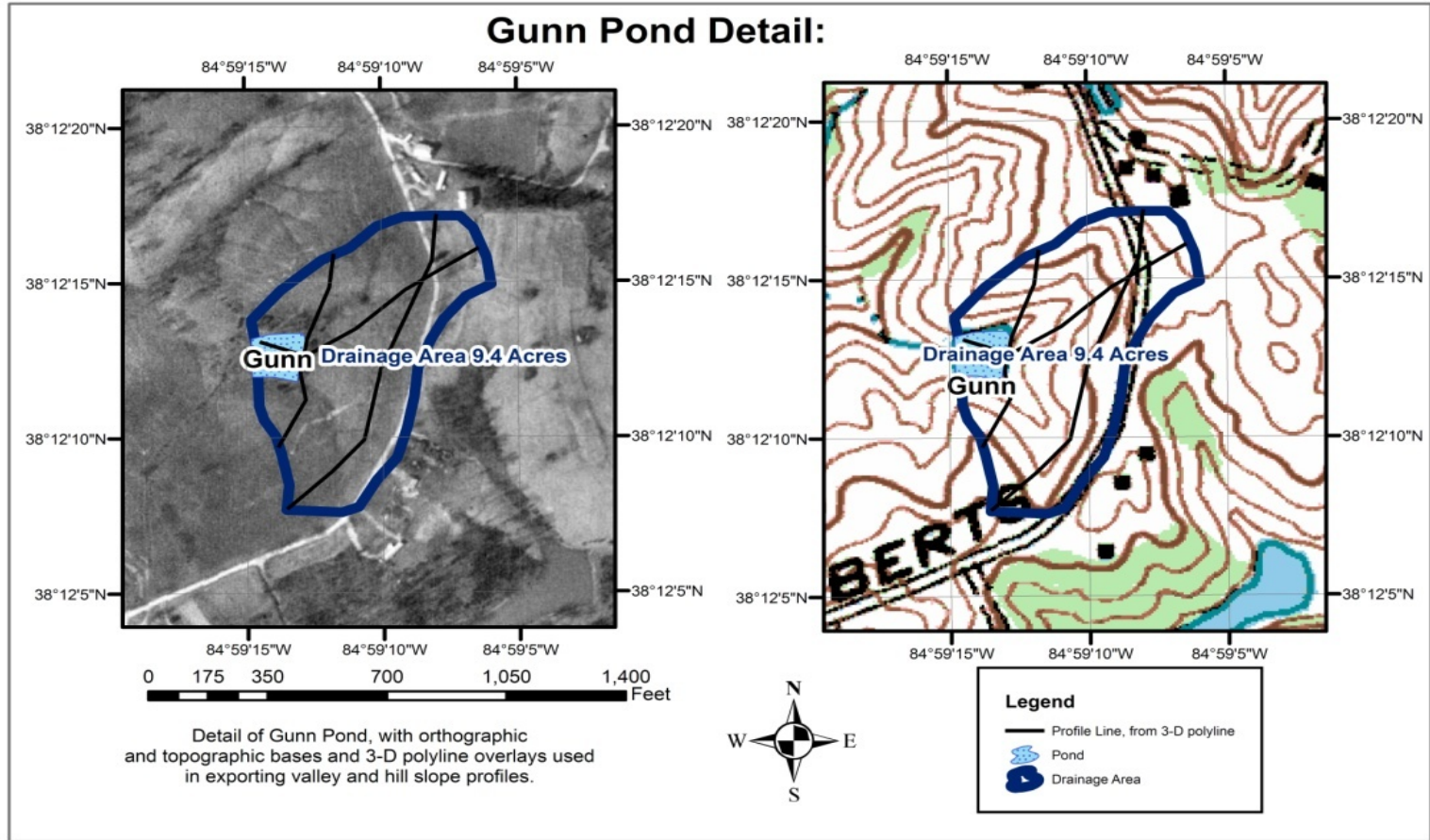

FIGURE 50 - Orthographic and topographic layout of Gunn pond site.

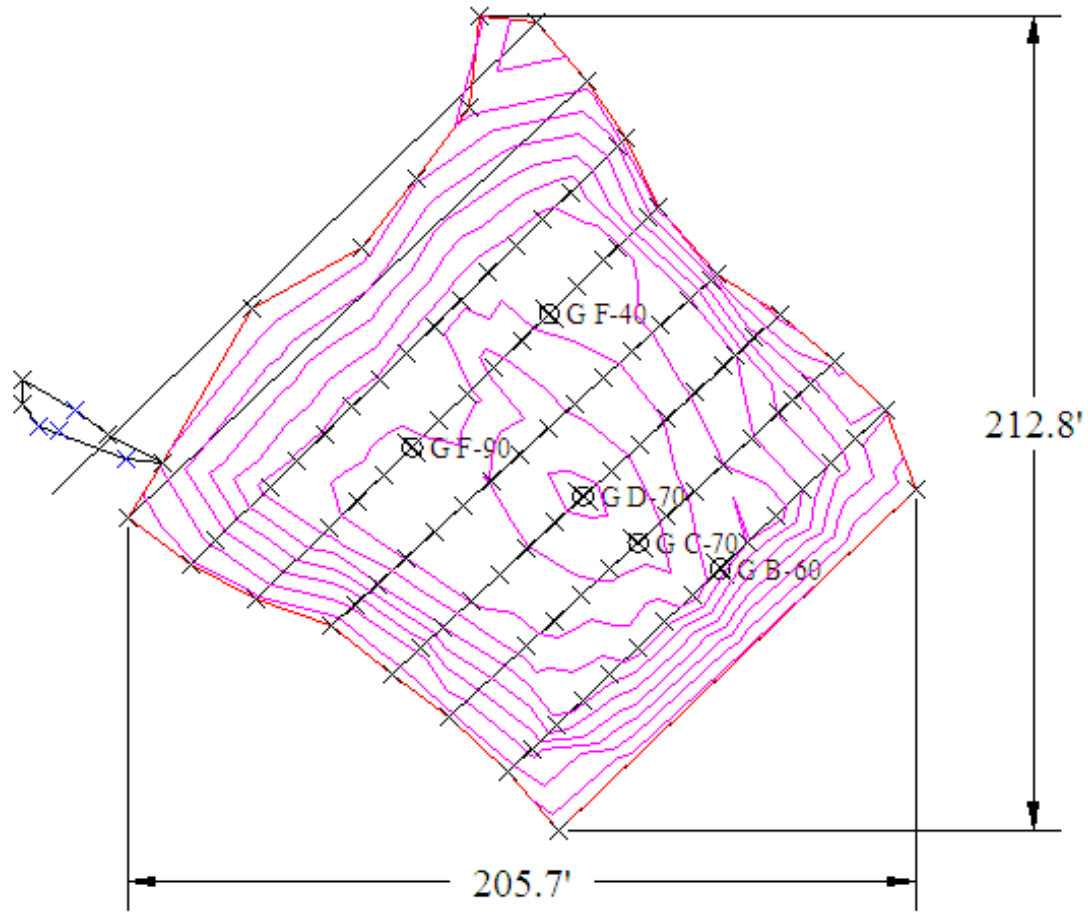

FIGURE 51 - AutoCAD layout of Gunn site showing pond (red), sediment toe (black), bathymetric survey points, and core locations, bottom of sediment represented by purple contours, dimensions in feet.

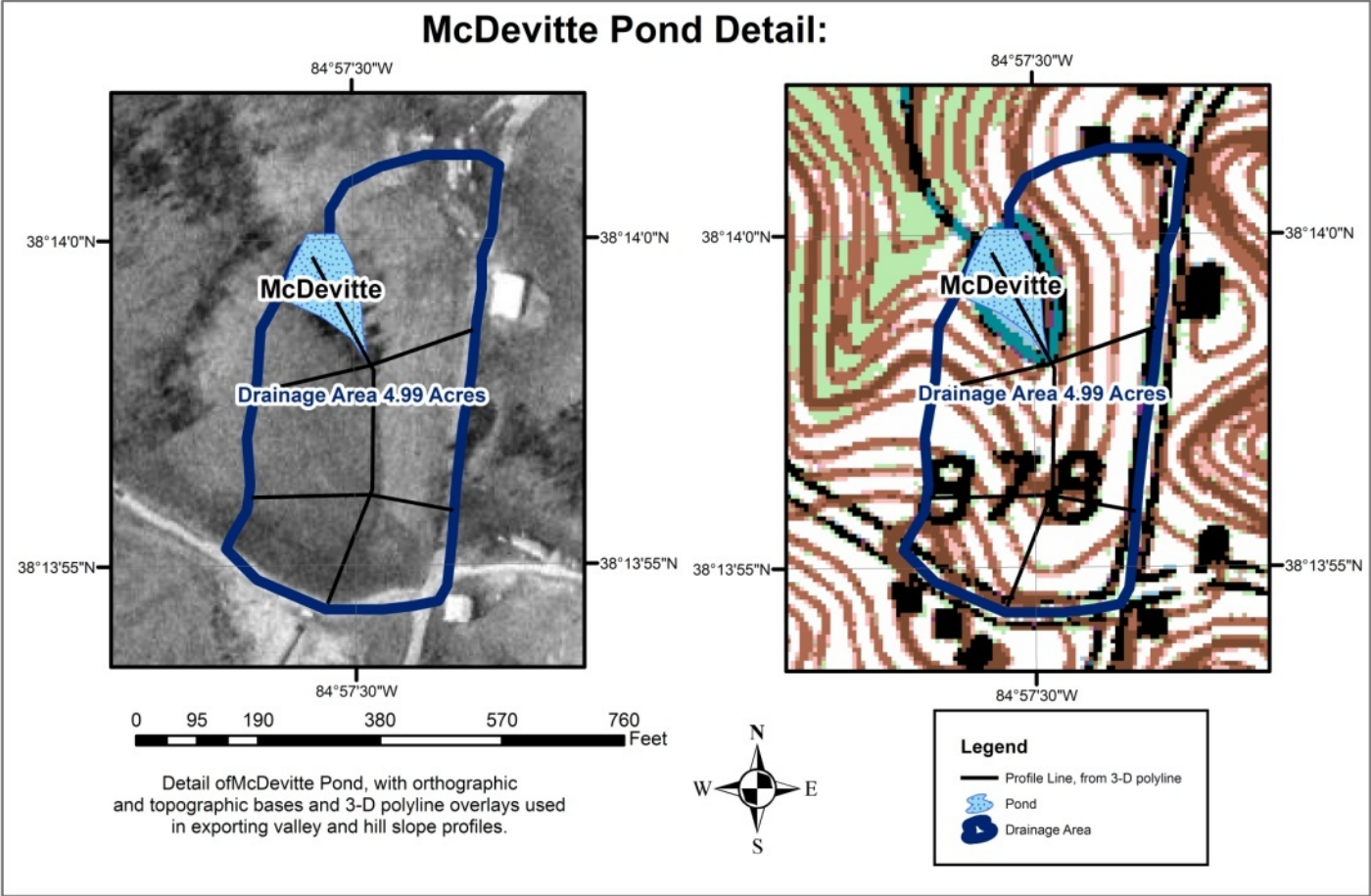

FIGURE 52 - Orthographic and topographic layout of McDevitte pond site.

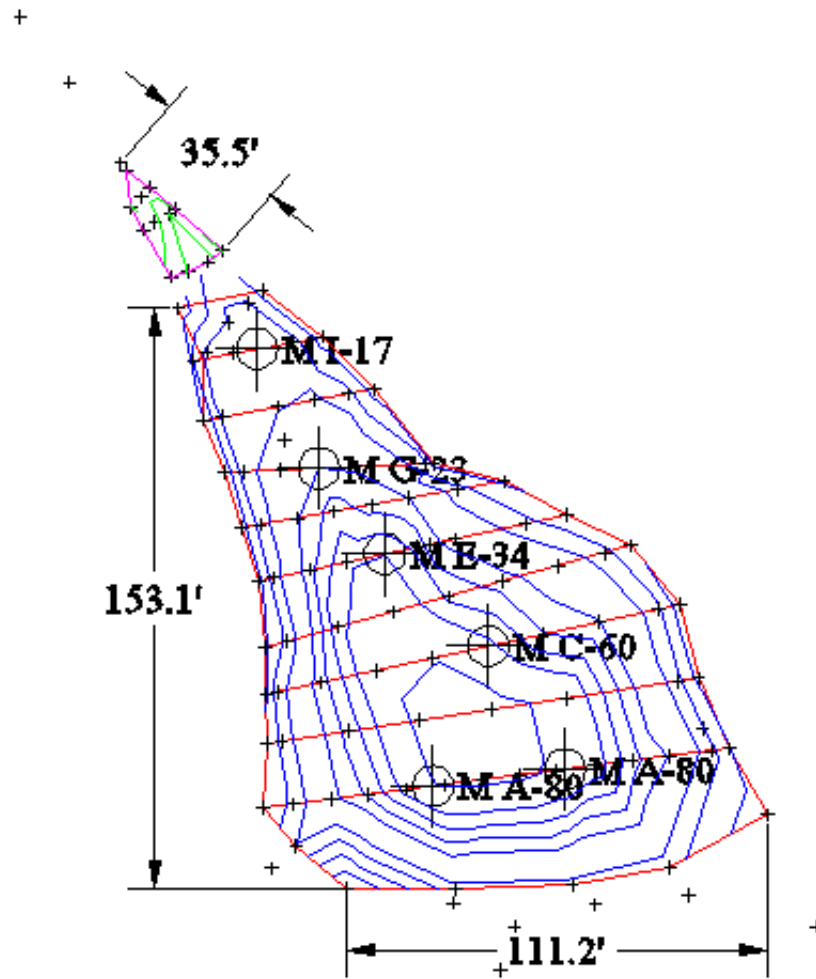

FIGURE 53 - AutoCAD layout of McDevitte site showing pond (red), sediment toe (purple), bathymetric survey points, and core locations, bottom of sediment represented by blue contours, dimensions in feet.

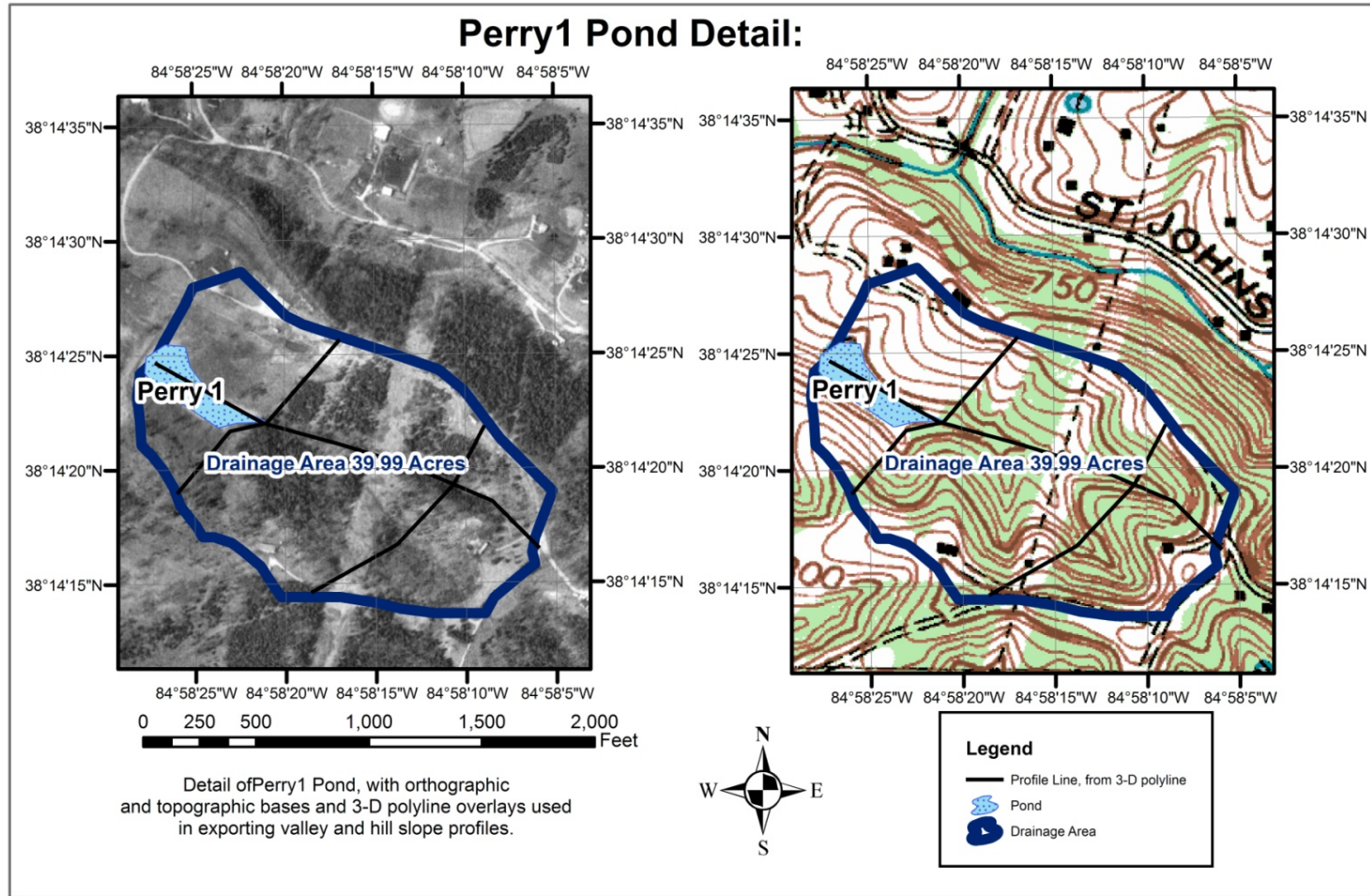

FIGURE 54 - Orthographic and topographic layout of Perry 1 pond site.

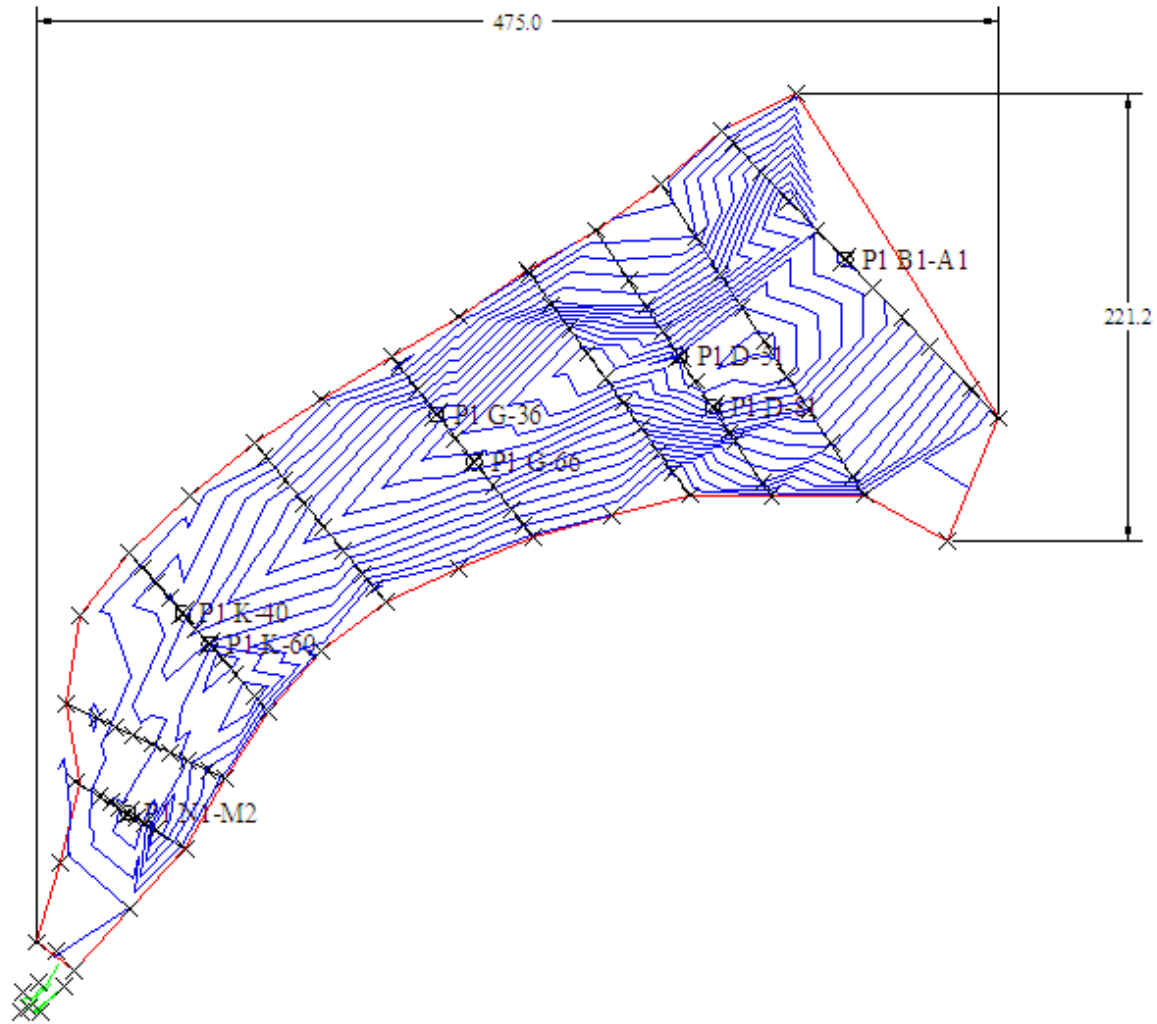

FIGURE 55 - AutoCAD layout of Perry 1 site showing pond (red), sediment toe (green), bathymetric survey points, and core locations, bottom of pond sediment represented by blue contours, dimensions in feet.

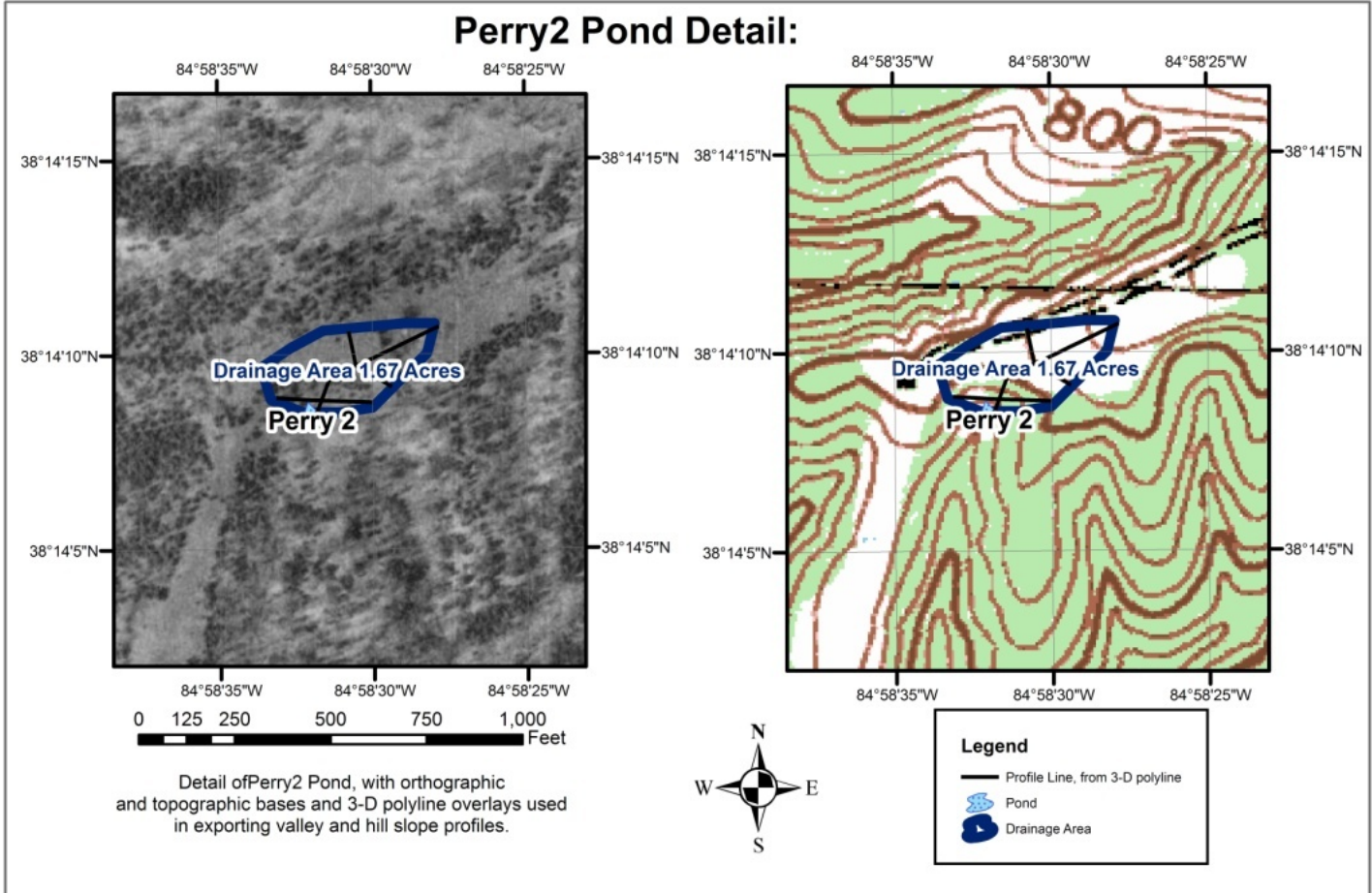

FIGURE 56 - Orthographic and topographic layout of Perry2 pond site.

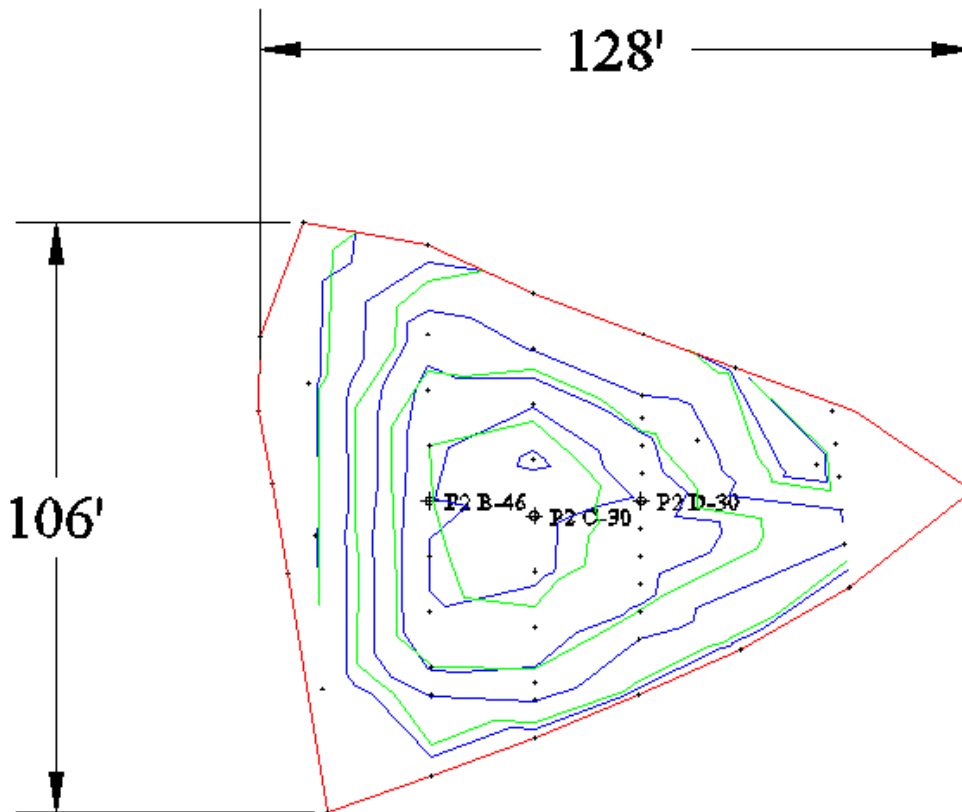

FIGURE 57 - AutoCAD layout of Perry2 site showing pond (red outline), bathymetric survey points, and core locations, blue contours represent pond sediment bottom, green contours represent top of sediment, dimensions in feet.

VITA

The author, Michael Borchers, was born in Dayton, Ohio, in 1968. After earning a Bachelor's of Science in Geological Sciences from The Ohio State University in 1994, he moved to Louisville, Kentucky, where he worked in the telecommunications and brewing industries.

In 2004, Mr. Borchers enrolled in the University of Louisville's Speed School of Engineering where he focused on water resources and geotechnical coursework. While at the University of Louisville, he completed three semesters of cooperative internship at the Stream Institute, a research group focusing on stream restoration. He received a Bachelor's of Science in Civil and Environmental Engineering in 2008.

In May of 2009, Mr. Borchers began employment at the U.S. Army Corps of Engineers, Louisville Division, in their hydrology and hydraulics section.