

2015-08-03

# Design of GFRP Reinforcement for Concrete Bridge Structural Components

Valentino Rinaldi

*University of Miami*, [rinaldi.valentino@tiscali.it](mailto:rinaldi.valentino@tiscali.it)

Follow this and additional works at: [https://scholarlyrepository.miami.edu/oa\\_theses](https://scholarlyrepository.miami.edu/oa_theses)

---

## Recommended Citation

Rinaldi, Valentino, "Design of GFRP Reinforcement for Concrete Bridge Structural Components" (2015). *Open Access Theses*. 578.  
[https://scholarlyrepository.miami.edu/oa\\_theses/578](https://scholarlyrepository.miami.edu/oa_theses/578)

This Open access is brought to you for free and open access by the Electronic Theses and Dissertations at Scholarly Repository. It has been accepted for inclusion in Open Access Theses by an authorized administrator of Scholarly Repository. For more information, please contact [repository.library@miami.edu](mailto:repository.library@miami.edu).

UNIVERSITY OF MIAMI

DESIGN OF GFRP REINFORCEMENT FOR CONCRETE BRIDGE STRUCTURAL  
COMPONENTS

By

Valentino Rinaldi

A THESIS

Submitted to the Faculty  
of the University of Miami  
in partial fulfillment of the requirements for  
the degree of Master of Science

Coral Gables, Florida

August 2015

©2015  
Valentino Rinaldi  
All Rights Reserved

UNIVERSITY OF MIAMI

A thesis submitted in partial fulfillment of  
the requirements for the degree of  
Master of Science

DESIGN OF GFRP REINFORCEMENT FOR CONCRETE BRIDGE STRUCTURAL  
COMPONENTS

Valentino Rinaldi

Approved:

---

Antonio Nanni, Ph.D.  
Professor of Civil, Architectural,  
and Environmental Engineering

---

Marco Savoia, Ph.D.  
Professor of Civil Engineering  
University of Bologna

---

Francisco J. De Caso y Basalo, Ph.D.  
Research Assistant Professor  
of Civil, Architectural,  
and Environmental Engineering

---

Dean of the Graduate School

RINALDI, VALENTINO

(M.S., Civil Engineering)

Design of GFRP Reinforcement for Concrete  
Bridge Structural Components

(August 2015)

Abstract of a thesis at the University of Miami.

Thesis supervised by Professor Antonio Nanni.

No. of pages in text. (277)

The demand for the development of a more efficient and durable transportation infrastructure is among the priorities of highway authorities worldwide. In the United States, the economic impact of steel corrosion for concrete highway bridges is estimated to exceed 15 percent of the total annual costs. Glass fiber reinforced polymer (GFRP) is highly suitable as internal reinforcement for structures subjected to corrosive environments.

A number of projects have demonstrated its viability as an alternative reinforcement for bridge decks and design provisions are currently available in several countries. Nowadays, manufacturers can produce standard bar bends which can be applied to design and construct bridge components, such as pile caps and traffic barriers. The implementation of GFRP requires addressing changes in the current design philosophy for bridge structures.

Whereas the overall goal of the research program is to make new technology available to bridge owners and professionals, this thesis provides principles and procedures for the design of highway concrete bridge components reinforced with GFRP bars.

*To my family,  
for their love, support and encouragement*

*Quando desideri qualcosa, tutto l'Universo cospira  
affinché tu possa realizzare il tuo desiderio.*

*Paulo Coelho*

## ACKNOWLEDGMENTS

I would first like to acknowledge the University of Miami and the University of Bologna. I recognize that without their will this voyage would not have been possible.

I sincerely thank Dr. Antonio Nanni for his guidance and mentorship on this project as well as on other aspects of my education as an engineer. I would also like to give thanks to my committee members Dr. Francisco J. De Caso y Basalo and Professor Marco Savoia for their support during this year.

To my team colleagues Yading Dai and Guillermo Claire, for their collaboration in this work and the passion that they transmitted me, many thanks.

Recognition goes to all the professors, students and staff of the CAE Department, the College of Engineering, the Graduate School and Study Abroad.

Appreciation to the student members of the American Society of Civil Engineers (ASCE) UM Chapter for the opportunities that have enriched my work and time as a graduate student at UM.

Thanks must be given to Jacopo Donnini, Simone Spagnuolo, Federica Selicato, Mauro Moro and all the other special people who shared with me their experience at UM.

This acknowledgement would not be complete without expressing my gratitude to my friends Francesca Dello Monaco and Lorenzo Urbinati. They have been my family throughout this journey and in their own special way have provided me with happiness.



## TABLE OF CONTENTS

	Page
LIST OF FIGURES .....	viii
LIST OF ABBREVIATIONS.....	ix
LIST OF SYMBOLS .....	xi
Chapter	
1 INTRODUCTION	
1.1 Research significance.....	1
1.2 Material characterization.....	4
1.3 Material challenges.....	9
1.4 The role of LCC/LCA.....	11
1.5 Objectives.....	13
1.6 Thesis outline.....	14
2 STUDY 1 _ DESIGN TOOL FOR GFRP RC MEMBERS	
2.1 Summary.....	15
2.2 Highway bridges.....	16
2.3 State of the art: GFRP bridge components.....	23
2.4 Design provisions.....	25
2.5 Design Requirements and loads.....	27
2.6 Analysis and design.....	29
2.7 FDOT LRFD #2A Design example.....	36
2.8 CR490A Bridge over Halls river.....	38
2.9 University of Miami pedestrian bridge.....	40
2.10 Future research directions .....	42
2.11 Conclusions .....	43
3 STUDY 2 _ SAFETY-SHAPED CONCRETE RAILINGS AND TRAFFIC BARRIERS USING GFRP REINFORCEMENT	
3.1 Summary.....	45
3.2 Background.....	46
3.3 Design loads.....	48
3.4 State of the art: GFRP RC railings and barriers.....	51
3.5 Geometry definition and reinforcement layout.....	55
3.6 Analysis and design.....	57
3.7 Corner joint verification.....	61
3.8 Flexural and shear verification.....	63
3.9 Conclusions.....	64

WORK CITED.....	66
APPENDIX A: LRFD FDOT#2A Design Example .....	71
APPENDIX B: CR490A Bridge over Halls River: Drawings and Deck design calculations.....	226
APPENDIX C: University of Miami Pedestrian Bridge: Drawings and Deck design calculations.....	252
APPENDIX D: Standard GFRP bar bends.....	270
APPENDIX E: State of the art: GFRP RC railings and barriers .....	272

## LIST OF FIGURES

Figure 1.1 - 2013 ASCE Report Card for bridges.....	4
Figure 1.2 - Surface deformation patterns for commercially available GFRP bars: ribbed (top); sand-coated (middle); and wrapped and sand-coated (bottom).....	6
Figure 1.3 - Stress-strain diagram for steel and FRP beams.....	9
Figure 1.4 – (a) Bent bars in I-635 bridge deck over State Ave. in Kansas City (b) Typical failure mode of a bent GFRP.....	11
Figure 2.1 - (a) RC solid slab bridge (b) RC girder bridge (c) Steel truss bridge (d) RC arch bridge (e) RC cable stayed bridge (f) Steel suspension bridge.....	19
Figure 2.2 - Schematic representation of typical highway bridge structural Components.....	22
Figure 2.3 - I 635 bridge deck over State Ave. in Kansas City, Kansas.....	24
Figure 2.4 - HL 93 design truck loads: (a) Axle load, (b) Tandem load.....	28
Figure 2.5 - Design procedure for GFRP RC bridge components.....	31
Figure 3.1 - (a) Constant slope concrete barriers; (b) Safety shape concrete barriers.....	48
Figure 3.2 - Design Forces for Traffic barriers and railings.....	51
Figure 3.3 - Sequential photographs for Test 441382-1 .....	52
Figure 3.4 - Reconstruction of Bridge No. 14802301: (a) GFRP reinforcement cages prior to casting of railing, (b) open-post railing in service.....	53
Figure 3.5 Barrier geometry used for the design example: FDOT 2014 “Section Thru New Jersey Shape Railing”, 32 in in height (units in in.; 1 in. = 25.4 mm).....	56
Figure 3.6 - Yield line analysis of concrete parapet walls for impact within wall segment.....	58
Figure 3.7 - Failure of corner joint: (a) Free body diagram, (b) Internal forces.....	62
Figure 3.8 - Flowchart for barrier–deck connection design controlled by failure at corner.....	63

## LIST OF ABBREVIATIONS

AC	Acceptance Criteria
AASHTO	American Association of State Highways and Transportation Officials
ACI	American Concrete Institute
AISC	American Institute of Steel Construction
ASCE	American Society of Civil Engineers
ASD	Allowable Stress Design
ASTM	American Standards for Testing and Materials
CFRP	Carbon Fiber Reinforced Polymer
CSA	Canadian Standards Association
DOT	U.S. Department of Transportation
ESR	Evaluation Service Report
FDOT	Florida Department of Transportation
FEM	Finite Element Method
FHWA	Federal Highway Administration
FRP	Fiber Reinforced Polymer
GFRP	Glass Fiber Reinforced Polymer
GFRP RC	Concrete reinforced with Glass Fiber Reinforced Polymer bars
HCB	Hybrid Composite Beam
IBC	International Building Code
ICC	International Code Council
IEBC	International Existing Building Code

LFD	Load Factor Design
LRFD	Load Reduction Factor Design
MTQ	Ministry of transportation of Québec
NBI	National Bridge Inventory
NCHRP	National Cooperative Highway Research Program
RC	Ordinary (Steel) Reinforced Concrete
SLD	Service Load Design
TL	Test Level
TxDOT	Texas Department of Transportation

## LIST OF SYMBOLS

$C_d$	Compression force at deck connection section
$C_p$	Compression force at post connection section
$c$	Distance from extreme compression fiber to neutral axis
$c_b$	Distance from extreme compression fiber to neutral axis at balanced strain condition
$F_{f,d}$	Tension force in reinforcement deck connection section
$F_l$	Longitudinal vehicle impact force
$F_{np}$	Nominal strength of post–deck connection
$F_p$	Transverse load applied to post–deck connection
$F_t$	Transverse vehicle impact force
$F_v$	Vertical vehicle impact force
$f'_c$	Specified cylindrical compressive strength of concrete
$f_f$	Effective strength in GFRP reinforcement at the strength and extreme event limit state
$f_{fu}$	Design tensile strength of FRP, considering reductions for service environment
$f^*_{fu}$	Guaranteed tensile strength of FRP bar, defined as mean minus three times standard deviation
$f_r$	Concrete modulus of rupture
$H_e$	Height of applied transverse and longitudinal load line with respect to deck surface
$L$	Transverse length of distributed vehicle impact force
$l_d$	Development length
$l_{dc}$	Length of diagonal crack in corner joint

$M_d$	Deck moment at connection section
$M_u$	Ultimate bending moment
$T$	Tensile strength per unit width on diagonal crack
$t_d$	Thickness of bridge deck at connection with post
$V_c$	Nominal shear resistance provided by the concrete
$V_f$	Nominal shear resistance provided by the GFRP reinforcement
$V_n$	Nominal shear resistance
$\gamma_i$	Load factor
$\varepsilon_{cu}$	Ultimate strain in concrete
$\rho_f$	GFRP reinforcement ratio
$\rho_{fb}$	GFRP reinforcement ratio producing balanced strain conditions
$\phi$	Strength reduction factor
$\Phi_{sh}$	Strength reduction factor for shear

## **CHAPTER 1**

# **INTRODUCTION**

### **1.1 RESEARCH SIGNIFICANCE**

The corrosion of structures has a significant impact on the economy, including infrastructures, utilities, production and government. Many studies, both in the United States and abroad, have addressed the cost of corrosion. A benchmark study conducted by CC Technologies and Federal Highway Administration (FHWA), estimated the total direct cost of corrosion to be \$276 billion per year, which corresponds to 3.1 percent of the U.S. gross domestic product <sup>1</sup>. Civil infrastructure facilities deteriorate due to aging, overuse, misuse, exposure to aggressive environments, and lack of maintenance.

The infrastructure category is divided by the U.S. Department of Transportation into the following industry sectors: (1) highway bridges, (2) gas and liquid transmission pipelines, (3) waterways and ports, (3) hazardous materials storage, (5) airports, and (6) railroads. According to the 2012 National Bridge Inventory Database (NBI) <sup>2</sup>, the total number of highway bridges in the United States is approximately 600,000. Over two hundred million trips are taken daily across deficient bridges in the nation's 102 largest metropolitan regions. In total, one in nine of the nation's bridges is rated as structurally deficient, while the average age of the nation's 607,380 bridges is currently 42 years. The



vast majority of these structures built since 1950 are the reinforced-concrete and steel bridges, and many are subject to significant deterioration due to corrosion.

The dollar impact of corrosion on highway bridges is considerable: the annual direct cost for highway bridges is estimated to be 16.4 percent of the total infrastructure cost, consisting of \$3.79 billion for the annual cost to replace structurally deficient bridges over the next 10 years, \$2.00 billion for maintenance of concrete bridge decks, \$2.00 billion for maintenance of other bridge components and \$0.50 billion for the painting cost for steel bridges <sup>1</sup>.

The American Society of Civil Engineers (ASCE) is committed to protecting the health, safety, and welfare of the public, and as such, is equally committed to improving the nation's public infrastructure. Once every four years, America's civil engineers provide a comprehensive assessment of the nation's major infrastructure categories through the ASCE's Report Card for the U.S. infrastructure <sup>3</sup>. In 2013, the cumulative grade was D+. With the overall number of deficient structures continuing to trend downward, the grade for bridges was C+ (Figure 1.1). The Florida Section of ASCE released the original Report Card for Florida's Infrastructure in 2008. Regrettably most of the category grades have stayed the same or gotten worse since that time.

The national goal is to decrease the number of just structurally deficient bridges to 8 percent by 2020 and decrease the percentage of the population driving over all deficient bridges by 75 percent by 2020. The challenge for federal, state, and local governments is to increase bridge investments by \$8 billion annually to address the identified \$76 billion in needs for deficient bridges across the United States.

The Florida Department of Transportation (FDOT) is an executive agency acting to coordinate the planning and development of the transportation system in the state of Florida. FDOT submits a 5-year work program that includes all transportation projects planned for each fiscal year. It is a plan developed to maximize the department's production and service capabilities through innovative use of resources, increased productivity, reduced cost, and strengthened organizational effectiveness and efficiency. The work program for the year 2014/2015 through 2018/2019 consists of 6,987 projects, including the construction of 762 lane miles of roadway, reparation of 190 bridges and replacement of 76 bridges.

Better corrosion management can be achieved using preventive strategies at every level of involvement (owner, operator, user, government, federal regulators and general public). These strategies include the increase awareness of large corrosion costs and potential savings, change of policies, regulations, standards, management practices, advance of design practices and technology through research, development, and implementation.

Sustainability, resiliency, and ongoing maintenance must be an integral part of improving the nation's infrastructure. Infrastructure systems must be designed to protect the natural environment and withstand both natural and man-made hazards, using sustainable practices, to ensure that future generations can use and enjoy what we build today. Additionally, research and development should be funded to develop new, more efficient methods and materials for building and maintaining the nation's infrastructure. New technologies to prevent corrosion continue to be developed and they are available to further lower costs. GFRP acceptance can reduce significantly direct and indirect costs of

maintenance, rehabilitation, replacement of systems, and loss of productivity due to steel corrosion.



Figure 1.1 - 2013 ASCE Report Card for bridges.

## 1.2 MATERIAL CHARACTERIZATION

Glass fiber reinforced polymer (GFRP) is a composite materials. The word “composite” means “consisting of two or more distinct parts”. However, a material is considered composite when the composite properties are noticeably different from the constituent properties <sup>4</sup>.

GFRP is lightweight, high strength and does not corrode. It consists on a reinforcing phase (fibers) embedded into a matrix (polymer). The fibers provide strength and stiffness while the resin encapsulates them, thus transferring stresses and providing protection. Fibers commonly used to make FRP bars are glass, carbon, basalt and aramid. Glass fibers offer an economical balance between cost and specific strength properties; this makes them preferable in most reinforced concrete (RC) applications. Glass fiber is primarily made from silica sand and is commercially available in different grades. The

most common types of glass are electrical (E-glass), high-strength (S-glass), and alkali-resistance (AR-glass). Matrices are typically thermosetting resins such as epoxies, polyesters, and vinyl esters. In their initial form, thermoset resins are usually liquids or low melting-point solids and they are cured with a catalyst and heat, or a combination of the two. Unlike thermoplastic resins, once cured, solid thermoset resins cannot be converted back to their original liquid form or reshaped. Vinyl ester resins are generally coupled with glass fibers.

The typical cross-sectional shape of the bar is solid and round, but hollow and other shapes are available. The most common techniques used to manufacture GFRP bars is pultrusion. It is a continuous molding process that combines fiber reinforcement and thermosetting resin. This process is ideal for the continuous fabrication of composite parts that have a constant cross-sectional profile, such as bars. During pultrusion, the fibers are wetted in a resin bath consisting in accelerators, fillers catalysts and wetting agents. Following curing, the hardened GFRP product is cooled while being gripped and pulled by the pull mechanism, and cut to the required length. Finally, a bar surface deformation or texture, such as wound fibers, sand coatings, and separately formed deformations, is induced so that mechanical bonding is developed between GFRP rebar and concrete (Figure 1.2). The average production output of pultrusion process ranges from 1 to 5 linear ft/min (0.3 to 1.52 m/min) <sup>5</sup>.

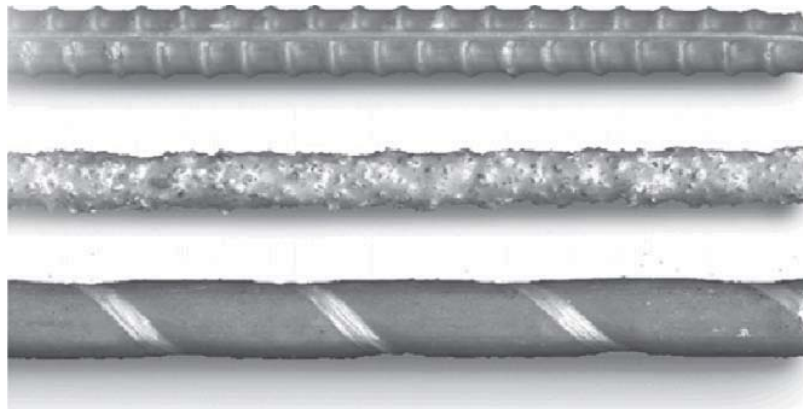

Figure 1.2 - Surface deformation patterns for commercially available GFRP bars: ribbed (top); sand-coated (middle); and wrapped and sand-coated (bottom).

GFRP bar size is designated by a number corresponding to the approximate nominal diameter in eighths of an inch, similar to standard ASTM steel reinforcing bars <sup>6</sup>. There are 10 standard sizes. When the GFRP bar is not of the conventional solid round shape (that is, rectangular or hollow), the outside diameter of the bar or the maximum outside dimension of the bar will be provided in addition to the equivalent nominal diameter. With the various grades, sizes, and types of FRP bars available, it is necessary to provide some means of easy identification. An example of standard identification symbols is:

XXX - G#4 - F100 - E6.0, where:

XXX = manufacturer's symbol or name;

G#4 = glass FRP bar No. 4 (nominal diameter of 1/2 in. (12 mm));

F100 = strength grade of at least 100 ksi ( $f_{tu}^* \geq 100$  ksi (689 MPa));

E6.0 = modulus grade of at least 6,000,000 psi (41 GPa).

GFRP bars have a density around 60 to 150 lb/ft<sup>3</sup> (1 to 2.5 g/cm<sup>3</sup>), one-sixth to one-fourth that of steel. GFRP is anisotropic, linear, elastic until failure and characterized by high tensile strength only in the direction of the fibers, with no yielding. If compared to steel, GFRP bars offer higher tensile strength but lower ultimate tensile strain (no yielding) and lower tensile modulus of elasticity (Figure 1.3). Because the resin has a much lower strength than the fibers, the ratio of the volume of fiber to the overall volume of the GFRP (fiber-volume fraction) significantly affects the tensile properties of a GFRP bar <sup>6</sup>. The tensile strength of GFRP bars vary with its diameter, while the longitudinal modulus does not change appreciably. Usually, a normal (Gaussian) distribution is assumed to represent the strength of a population of bar specimens <sup>7</sup>. Manufacturers should report a guaranteed tensile strength, defined as the average strength minus three times the standard deviation, and similarly report a guaranteed rupture strain, and a specified tensile modulus. These guaranteed values of strength and strain provide a 99.87 percent probability that the indicated values are exceeded by similar GFRP bars, provided that at least 25 specimens are tested <sup>8</sup>.

Due to the GFRP anisotropic and nonhomogeneous nature, the compressive modulus is lower than the tensile one. The compressive strength and compressive modulus are respectively around 50 percent and 80 percent of its tensile values. The mode of failure for GFRP bars subjected to longitudinal compression can include transverse tensile failure, fiber micro-buckling, or shear failure <sup>6</sup>. There is still little experience in the use of GFRP reinforcement in compression members and for moment frames or zones where moment redistribution is required.

The behavior of GFRP bars under transverse shear loading is mostly influenced by the properties of the matrix. GFRP bars are generally weak in transverse shear. Typical transverse shear strength ranges between 4.3 and 7.3 ksi (30 to 50 MPa). Bond stresses at the GFRP bar/concrete interface are transferred by chemical bond (adhesion resistance of the interface), friction, and mechanical interlock due to irregularity of the interface. In the GFRP bar, bond stresses are transferred through the resin to the reinforcement fibers. The bond behavior of a bar is, therefore, limited by the shear strength of the resin. Typical bond strength fluctuate around 1.5 ksi (10.3 MPa).

When subjected to a sustained tensile load, GFRP undergoes progressive deformations, which may ultimately lead to failure (creep rupture) after a period of time called “endurance time”. Test results showed that the percentage of initial tensile strength retained, linearly extrapolated at the 50-year endurance time, was about 30% for GFRP. Providers specify ultimate and sustained loads.

There is a strong relation between the mechanical properties and the environmental conditions. Under harsh environmental conditions (presence of water, high temperature, high exposure to UV light, and high alkalinity) tensile strength, bond resistance and endurance limits may reduce significantly. Durability studies conducted over the last decade indicate that the mechanical properties of GFRP used as internal reinforcement for concrete structural members decrease with time<sup>9</sup>. The exposure conditions consist of moisture fluctuations, freeze-thaw effects, temperature cycles, pH variations, and ultraviolet (UV) radiation. The degree of reduction in GFRP properties under varying environmental conditions depends on various factors such as type of fibers and resins, fiber sizing chemistry, cure conditions, quality control during manufacturing, and the

severity if external environmental agents. The type and quality of concrete influence the durability of GFRP reinforced concrete members.

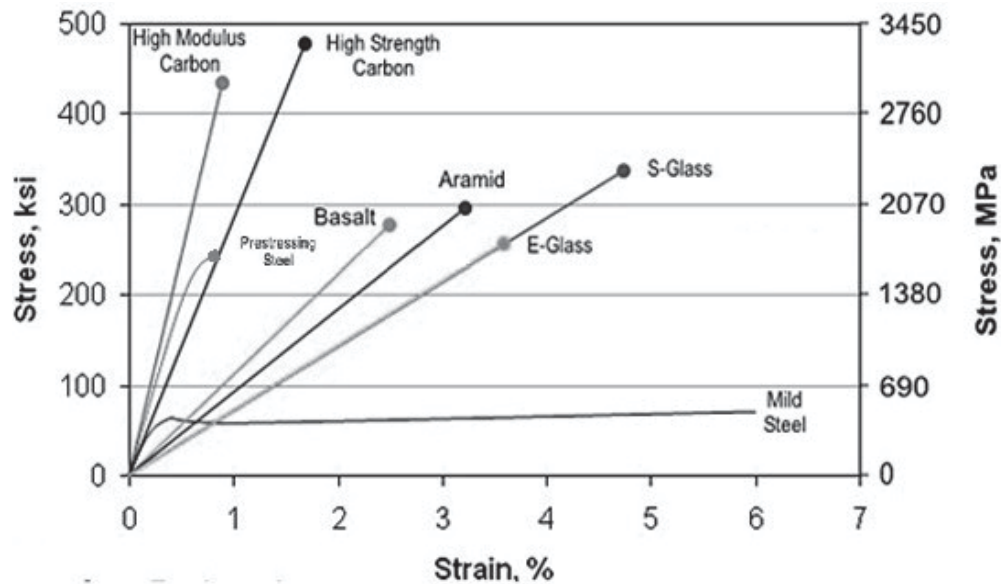

Figure 1.3 - Stress-strain diagram for steel and FRP beams.

### 1.3 MATERIAL CHALLENGES

Plain concrete is strong in compression, but weak in tension. For this reason, it was originally used for simple, massive structures, such as foundations, bridge piers, and heavy walls. Over the second half of the nineteenth century, designers and builders developed the technique of embedding steel bars into concrete members in order to provide additional capacity to resist tensile stresses. This pioneering effort has resulted in what we now call reinforced concrete (RC). Until a few decades ago, steel bars were practically the only option for reinforcement of concrete structures. The combination of



steel bars and concrete is mutually beneficial. Steel bars provide the capacity to resist tensile stresses. Concrete resists compression well and provides a high degree of protection to the reinforcing steel against corrosion as a result of its alkalinity.

Combinations of chlorides (depassivation of steel) and CO<sub>2</sub> (carbonation of concrete) in presence of moisture produce corrosion of the steel reinforcement. This phenomenon causes the deterioration of the concrete and, ultimately, the loss of the usability of the structure. Over the second half of the 1900s, the deterioration of several RC structures due to the chloride-ion induced corrosion of the internal steel reinforcement became a major concern. Various solutions were investigated for applications in aggressive corrosion environment. These included galvanized coatings, electrostatic spray fusion-bonded (powder resin) coatings, and polymer-impregnated concrete epoxy coatings. Eventually, fiber-reinforced polymer (FRP) reinforcing bars were considered as an alternative to steel for internal reinforcement of concrete.

The use of FRP systems for design of RC elements has become a viable technique, which was commercially introduced in the 90's<sup>10</sup>. Since then, numerous research studies have been conducted in order to analyze, study and comprehend the properties of these materials and their optimal uses.

The production of bar bends remains a challenge to GFRP bar manufacturers, and scarce information is available in the technical literature related to the method of production and available dimensions<sup>4</sup>. As research is developing, manufacturers start providing custom bends by forming the bar prior to the thermoset resin polymerization. Hence, it is possible to form a bar into J-shape, U-shape or a continuous spiral (Figure 1.4), widening the window of application of the GFRP technology. Bends must be

incorporated during manufacturing, because bars cannot be bent after curing when a thermoset resin is used. An exception to this would be a GFRP bar with a thermoplastic resin that could be reshaped with the addition of heat and pressure.

Current standards prescribe a strength reduction from 40 to 50 percent for GFRP bars produced with bends compared with the tensile strength of a straight bar <sup>6</sup>. ACI and AASHTO define the minimum values of inside bend radius for GFRP bars. Manufacturers, usually define the minimum specified longitudinal tensile stress resistance and tensile loads for bent bars, based on experimental results. Figure 1.4 shows the bent bars used for the construction of the I-635 bridge deck over State Ave. in Kansas City.



Figure 1.4 - (a) Bent bars in I-635 bridge deck over State Ave. in Kansas City (b) typical failure mode of a bent GFRP.

#### **1.4 THE ROLE OF LCC/LCA**

The increasing concerns regarding long term performance, environmental and health impacts of construction materials in the last decade has incentivized the development of

alternative environmentally-benign material systems; where the material selection has become a critical component in the decision making process during the design stage of a construction project <sup>52</sup>. This trend is reflected in the increasing number of green building projects on existing buildings through the United States Green Building Council's (USGBC) Leadership in Energy and Environmental Design (LEED) United States Green Building Council, (USGBC) <sup>53</sup>. Additionally, the interest and funding of private and government agencies, such as the National Science Foundation (NSF) Industry/University Cooperative Research Center for the Repair of Buildings and Bridges, reflects the significance of sustainable construction materials <sup>54</sup>. GFRP has become an interesting alternative and it has attracted increasing attention for applications in the construction of new bridges. The benefits brought by lightweight, high-strength GFRP materials to these applications are well recognized. Despite the advantages offered by GFRP, it might seem unattractive due to their relative high initial cost when compared to traditional reinforcing materials such as steel. The reality, is that are initial cost is only a small portion of the total cost that should be considered. Life-cycle cost (LCC) analysis, which sums up the total life-cycle cost including all costs from acquisition to demolition, is an evaluation method to assess the economic viability of projects. In addition, the environmental impact of bridges in a life-cycle perspective has gained attention from bridge authorities due to today's extensive resource consumptions. Life-cycle assessment (LCA) is used to assess the environmental impacts of a product from cradle to grave. The emergence of the Life Cycle Assessment (LCA) and Life Cycle Cost (LCC) methods in construction is the effect of the growing awareness that environmental problems require a comprehensive assessment and intervention. In the

United States, state and federal agencies use these methodologies to justify innovative materials and new technologies. Together, LCC and LCA analyses are valuable tools for aiding in the decision-making process in order to achieve cost efficient and/or environmental friendly infrastructure projects. To this end, in order to truly evaluate and understand the full benefits when implementing composite technologies instead of traditional materials to reinforce reinforced concrete, LCC and LCA are essential tools that need to be implemented.

## **1.5 OBJECTIVES**

The information presented in this work is part of a more extensive research program, which overall goal is to make the technology of bridge reinforcement with composites fully available to bridge owners and professionals. Concrete and steel are the main construction materials used in bridge engineering. Degradation related to corrosion of steel reinforced concrete members exposed to harsh environmental conditions compromise the durability of bridges. Consequently, the cost of replacement and maintenance leads to a significant impact on the economy of many countries. The use of GFRP bars as internal reinforcement for concrete bridge components generates a significant potential for extending the service life of these structures.

Since GFRP is a practically viable solution to replace steel in different components of common highway bridges, the objective of this thesis is to create tools to spread the use of GFRP as internal reinforcement.

In this thesis the basic principles to understand the material properties and the design philosophy of GFRP RC members are discussed. Recent research advances and standard

procedures are implemented in order to set up a simple method for the design of GFRP RC components. A design example and a field application are developed in accordance with state and federal requirements to evaluate the viability of this construction technology.

## **1.6 THESIS OUTLINE**

Articulated in two studies and supported by five appendices, the dissertation investigates the viability of structural bridge components designed with GFRP reinforcement. Study 1 introduces a protocol for the use of GFRP bars in elements of highway bridges. Design and verification are performed according to current provisions in a MathCad language. A procedure for the design of concrete cast-in-place deck and pier cap is implemented. Three case studies reported in the Appendices A, B and C demonstrate the validity of the design tool developed and the viability of GFRP to reinforce concrete bridge components exposed to aggressive environmental conditions.

Study 2 introduces a reinforcement layout for concrete parapets using GFRP bent bars. The design is performed with the strength-convergence procedure in MathCad language, based on recent research programs of similar types of connections. The most relevant reinforcement layouts for different types of traffic barriers are reported in Appendix E. Results showed that the proposed methodology is simple, effective and reliable. The basic principles for traffic barrier design are introduced and a design example is outlined in Appendix A.

## **CHAPTER 2**

# **STUDY 1 \_DESIGN TOOL FOR GFRP RC MEMBERS**

### **2.1 SUMMARY**

The majority of applications utilize GFRP bars to mitigate the risk of corrosion in concrete structures that operate in aggressive environments. The service life of these types of structures is strictly contingent to the durability of the internal reinforcement. Most modern highway bridges contain RC elements. The use of GFRP bars as internal reinforcement for concrete structures subjected to aggressive environments generates a significant potential for extending the service life of these structures and lowering their overall life cycle cost. For this reason, bridges or their components are the most common application of GFRP internal reinforcement.

More than 190 installations use FRP composites in the United States. In more than 50 installations, GFRP bars are used in bridge decks. Research and technology advances allow to experiment design procedures for others flexural bridge components internally reinforced with GFRP bars.

Study 1 aims to create a protocol for bridge designers and transportation officials to design GFRP RC bridge components mainly subjected to transverse loads. The design procedure described in this chapter is implemented to create a MathCad based program, which accounts for automated verification of concrete elements reinforced with GFRP

bars. The effectiveness of the design tool and the viability of GFRP as internal reinforcement for bridge components are demonstrated through three case studies, where pile cap and deck reinforcement is designed.

## **2.2 HIGHWAY BRIDGES**

In highway systems, bridges maintain the continuation of the roadway, for the traffic of vehicles and/or pedestrians. The American Association of State and Highway Transportation Officials (AASHTO) design specifications defines highway bridges as any structure having an opening not less than 20 ft (6.1m) that forms part of a highway or that is located over or under a highway <sup>11</sup>. Concrete and steel are the main construction materials used in bridge engineering. Most modern small highway bridges are of steel reinforced concrete construction and nearly all modern bridges contain RC elements <sup>12</sup>. Concrete bridges come in all shapes and sizes. Designs can meet whatever functional, aesthetic and economic criteria are appropriate to the site location and needs of the client. Based on the superstructure type, highway bridges may be recognized as slab bridges (or deck bridges), girder (or beam) bridges, arch bridges, truss bridges, cable stayed bridges, and suspension bridges. Figure 2.1 shows typical examples of these types of bridges.

Span-to-depth ratio has to satisfy safety, serviceability, and constructability requirements. It varies with bridge type and span length. Typical ranges of span-to-depth ratios for concrete bridges are 22 to 39 for cast-in-place solid slab, 19 to 35 for cast-in-place voided slab, 17.7 to 22.6 for cast-in-place girder <sup>13</sup>.

Slab bridges refer to those bridges with a reinforced concrete slab as the superstructure without beams. Girders do not apply to this type of construction, since the deck transfers

the loads directly to the pier caps or abutments. The slab would have to be thicker than the deck in beam bridges, since there are no beams supporting the slab. This would increase the self-weight and thus the cost for the bridge. Consequently slab bridges are usually short span. Ease of construction resulting from the simplicity makes solid deck bridges the most economic type for short span structures. Structures longer than about 35 ft (11 m) are quite unusual; concrete bridges of this size are usually pre-stressed.<sup>12</sup>. Another exception is very short span shallower structures (typically up to some 6 m or 19.7 ft span) which can be most economically precast effectively complete as box culverts. Above a span of 11 m (about 35 ft), the dead weight of a solid deck bridge starts becoming excessive. In these cases, lighter forms of construction are desirable, such as voided deck bridges<sup>12</sup>.

Beam (or girder) bridges represent the most popular highway bridges in the world. More than 90% of highway bridges are beam or girder bridges in the United States. Girder bridges are applicable in span lengths from approximately 90 to 500 ft (about 25 to 150 m)<sup>14</sup>. The span length of girder bridges usually ranges within 300 ft (91.44m) to be cost effective<sup>15</sup>.

Truss bridges are typically made of steel. Trusses behave as large beams to carry loads, but are comprised of discrete members that are subjected primarily to axial loads. The members are generally arranged to form a series of triangles that act together to form the structural system. Trusses are generally not cost-effective for span lengths under 450 ft (137.2 m). Below 450 ft (137.2 m) the labor required to fabricate and erect a truss will generally exceed any additional material cost required for a deck girder design. The



practical upper limit for simple span trusses is approximately 750 ft (228.6 m), while continuous trusses begin to be cost-effective when the span length exceeds 550 ft <sup>14</sup>.

Arches carry loads in a combination of beam action and axial forces. Arches can have either trussed or solid ribs. Solid ribbed arches are generally used for shorter spans. Trussed arches tend to become economically feasible as the span lengths increase past 1000 ft (304.8 m) <sup>14</sup>.

Cable-stayed and suspension bridges are used for long and extremely long span bridges. Suspension bridges are also cable-suspended structures but use a different system. As with cable stayed structures, suspension bridges rely on high-strength cables as major structural elements <sup>14</sup>. Cable-stayed bridges have been constructed with main span lengths less than 200 ft and extending up to nearly 3000 ft (914.4 m). In the U.S., cable-stayed bridges become very cost competitive for main span lengths over 750 ft (228.6 m). Prior to 1970, it was generally considered that suspension bridges provided the most economical solution for span lengths in excess of about 1200 ft (365.8 m). With the development of cable-stayed bridge technology, suspension bridges do not become economical until the main span length approaches 3000 ft (914.4 m).

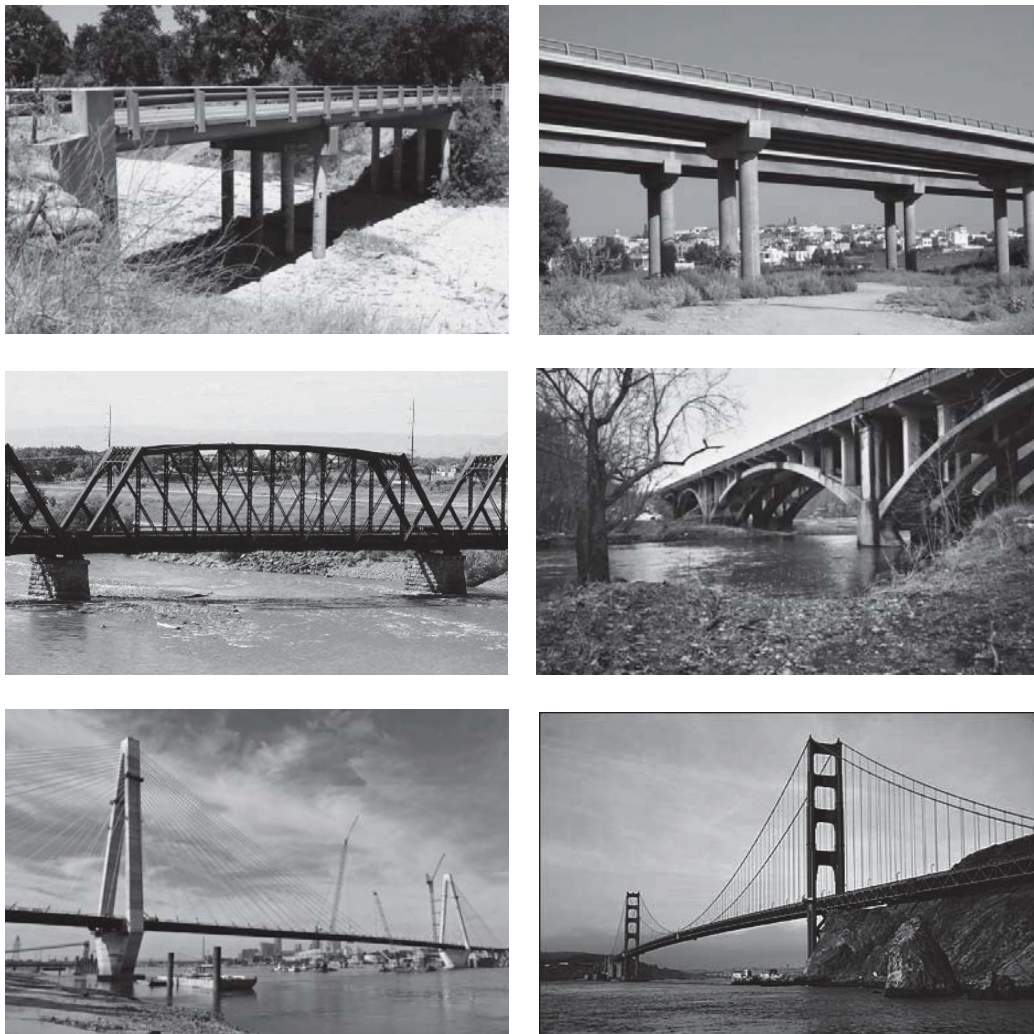

Figure 2.1 - (a) RC solid slab bridge (b) RC girder bridge (c) Steel truss bridge (d) RC arch bridge (e) RC cable stayed bridge (f) Steel suspension bridge.

The elements of a typical bridge structure can be classified into two primary components, the substructure and the superstructure. The substructure refers to the elements of the bridge that transfer the loads from the bridge deck to the ground (bearings, abutments, piers, pier caps, foundations). The superstructure refers to the elements of the bridge above the substructure, including the deck, supporting members

(beams, trusses, girders, arches, or cables), bracing (or diaphragms) and traffic barriers. Figure 2.2 shows a schematic representation of typical highway bridge structural components.

The traffic barriers contain and redirect errant vehicles allowing deceleration to a stop at a relatively short distance from the impact section. The details related to types, requirements, loads and design methods are described in Study 2.

The deck supports or directly provides a driving surface to vehicle traffic on a highway bridge. The surface is required to be aligned and consistent with the roadway surface connecting to the bridge for a smooth and comfortable ride. The most popular deck system in modern highway bridge construction in the world is the cast-in-place solid RC slab composite or non-composite to the supporting members. One of the major advantages of this deck system is the ease and speed of construction. The composite action increases the load-carrying capacity in supporting beams and thus reduces cost. This function also increases the redundancy of the superstructure system and its structural system reliability against failure <sup>15</sup>. Moreover, the monolithic nature of cast-in-place concrete deck allows creating a water-tight surface which can protect other bridge components from the accelerated deterioration caused by water leakage.

The deck-supporting system transfers the vehicle load and other loads from the deck system to the substructure and then to the ground. In beam bridges, the beams are the primary superstructure members supporting the deck and transferring the load to the bearings and/or the substructure. The system usually consists of a number of parallel beams that form a frame using some connections between them, such as diaphragms and

bracings. Examples of beam bridge deck-supporting systems are steel beams, prestressed concrete I beams, prestressed concrete box beams adjacent to each other.

The bearings serve to accommodate displacements and rotations of the superstructure components reducing the forces transferred to the substructure. According to their functions, bearings can be categorized as expansion and fixed bearings. Expansion bearings allow superstructure displacement on the longitudinal and vertical direction and rotations. Fixed bearings refer to those that restrain translation movements but accommodate uniaxial or multiaxial rotation.

The abutments are the structures supporting the end of end spans connecting to the road and retaining the soil behind it. There are usually two abutments for two ends of the entire bridge. The AASHTO design specifications categorize abutments according to their relation to the approach fill <sup>11</sup>: full-depth (or full-height) abutments are typically located at the approximate front toe of the approach embankment, restricting the opening under the bridge and making the bridge span shorter. Stub abutments are typically located at or near the top of approach fills, usually supported on a pile foundation. Compared with full-depth abutments, stub abutments make the bridge span longer. Partial-depth (or partial-height or semi-stub) abutments are located approximately at mid-depth of the front slope of the approach embankment. In other words, they are between stub and full-depth abutments with respect to their relation to embankment.

A pier cap (or pile cap) provides an intermediate support for the superstructure system. Its location determines the span length and the orientation is transverse, or partially transverse in presence of skew, to the traffic direction. It is generally a reinforced concrete element cast-in-place to form a frame with the piers.

The piers are structures that provide intermediate supports to spans receiving the load from the cap, as opposed to abutments, which provide only end supports of the entire bridge. RC piers can be single-column, multicolumn, and wall piers<sup>15</sup>. Single-column piers are referred to as T columns and hammerhead columns depending on the shape or appearance. Multicolumn piers are designed as frames in the plane of the pier (perpendicular to the longitudinal axis of the bridge if there is no skew), with moment-resisting connections between the cap and each column. Wall piers use a wall to support the superstructure between abutments at the ends of a bridge. They may be pinned or fixed or free at the top and are conventionally fixed at the base. Short piers are often pinned at the base to eliminate the high moments experienced if otherwise fixed.

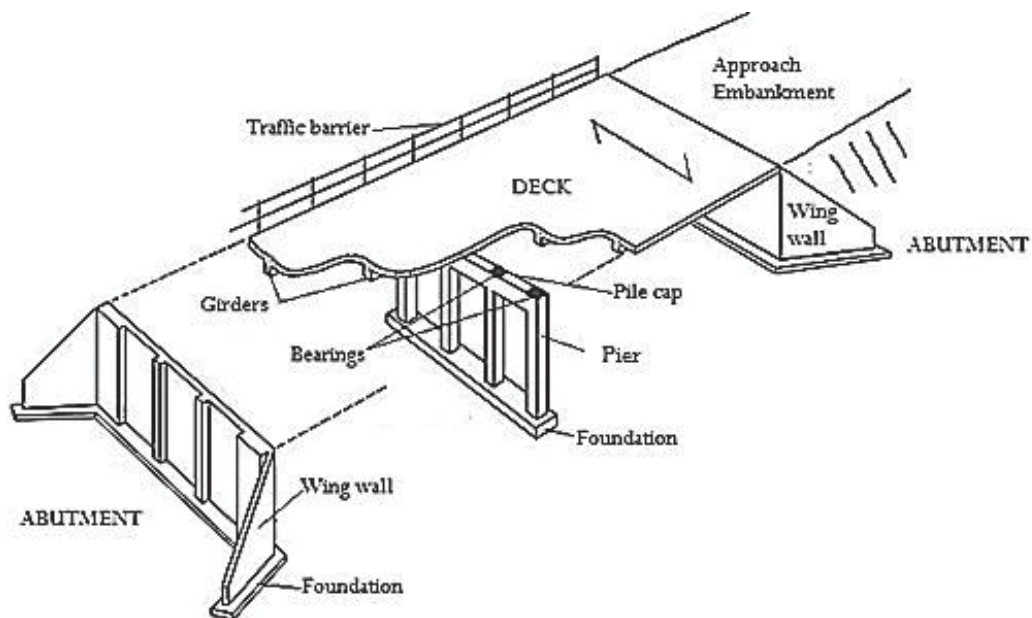

Figure 2.2 - Schematic representation of typical highway bridge structural components.

### 2.3 STATE OF THE ART: GFRP RC BRIDGE COMPONENTS

In the United States more than 190 installations use FRP composites. At the moment 16 states use FRP bars in bridge decks. In Canada, more than 195 installations use FRP composites. 190 installations use GFRP bars in bridge decks, parapets, barriers and sidewalks <sup>16</sup>. The majority of applications utilize GFRP bars to mitigate the risk of corrosion in concrete structures that operate in aggressive marine environments or are exposed to deicing salts.

Up to the mid-1990s, the Japanese had the most FRP reinforcement applications, with more than 100 demonstration or commercial projects. In the 2000's, China became the largest user of composite reinforcement for new construction in applications that span from bridge decks to underground <sup>16</sup>. The use of FRP reinforcement in Europe began in Germany with the construction of a prestressed GFRP highway bridge in 1986 <sup>17</sup>. Since the construction of this bridge, 21 programs have been implemented to increase the research and use of FRP reinforcement in Europe<sup>18</sup>. Canadian civil engineers have developed provisions for FRP reinforcement in the Canadian Highway Bridge Design Code <sup>19</sup> and have constructed a number of FRP RC structures. The Headingley Bridge in Manitoba included both CFRP and GFRP reinforcement <sup>20</sup>. The Floodway Bridge over the Red River in Winnipeg, Manitoba, Canada, was completed in 2006. The bridge comprises 16 spans, each approximately 6.5 by 143 ft (15.3 by 43.5m). All concrete elements above the girders are reinforced with GFRP bars. The project consumed 310,000 lb (140,000 kg) of GFRP rebar, making it the largest nonmetallic RC bridge in the world. Moreover, several bridges have been built in Québec using GFRP bars in the

decks, such as the Wotton Bridge in Wotton, the Magog Bridge on Highway 55 North, the Cookshire - Eaton Bridge on Route 108, and the Val-Alain Bridge on Highway 20 East <sup>21</sup>. Some of these bridges have been in-service for more than 10 years without any signs of deterioration of the GFRP reinforcement. Consequently, there is a remarkable increase in the use of GFRP bars in Canada where more than 200 bridge structures have been successfully constructed. Straight and bent FRP bars were used for the deck slab and/or for the concrete barriers and girders of the bridges failure <sup>6</sup>. GFRP rebar is also found on larger and high volume traffic bridges. In 2013, the I-635 bridge deck over State Ave. in Kansas City, Kansas was replaced with cast in place GFRP rebar. GFRP rebar were used in the top and bottom mat of the deck as shown in Figure 2.3. The bridge is 32 ft wide and 232 ft long (9.8 m x 70.7 m). Construction bids for this project were the same for installed cost of epoxy coated as well as GFRP reinforcement.

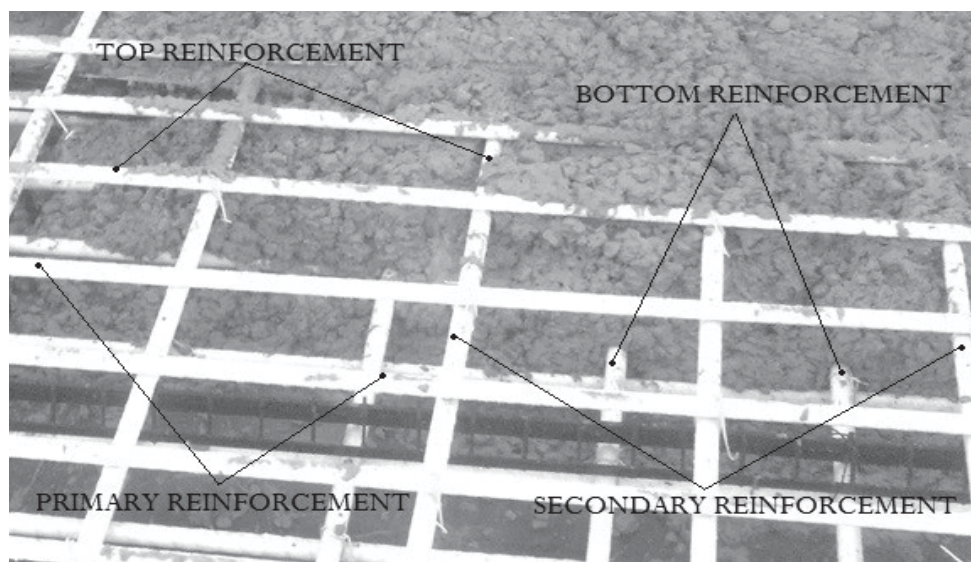

Figure 2.3 - I 635 bridge deck over State Ave. in Kansas City, Kansas.

## 2.4 DESIGN PROVISIONS

Standards (codes, specifications and test methods) are documents to follow when designing buildings and transportation structures. Standards are mandatory language documents. Codes speak to designers (architects and engineers), construction specifications speak to contractors. It is important to distinguish between building and transportation structures provisions.

Buildings provisions are enforceable at the local level when a jurisdiction adopts a building code. Typically, a building code is adopted at the state level and used locally (exceptions are large cities like New York City). Building codes are collections of mandatory provisions that specify minimum requirements for design, construction, inspection and occupancy. The International Building Code (IBC) <sup>22</sup> establishes the minimum requirements to safeguard health and safety in new buildings and has been adopted by all the 50 states of the Union. For any standard to have a legal status and be enforceable by a building official, it must be referenced by IBC or any other document part of the International code family (I-Codes). The designer must satisfy material and design requirements and can provide additional restrictions, based on his/her knowledge.

As far as material provisions are concerned, the I-Codes do not recognize GFRP as an alternative construction material technology <sup>22, 23</sup>. However, the designer is allowed to implement GFRP into construction in presence of valid research reports from approved sources accredited under ISO/IEC 17065 (Section 104.11 IBC). In other words, the material must be certified with an evaluation service report (ESR) <sup>22, 24</sup>. The role of acceptance criteria is to establish requirements for testing and evaluation of GFRP



products that can be certified by ISO/IEC 17065: AC454 (Acceptance criteria for glass-fiber reinforced polymer (GFRP) bars for internal reinforcement of concrete members) <sup>25</sup>. The American Concrete Institute (ACI) provides an exhaustive guideline for the design of concrete members reinforced with GFRP bars: ACI 440.1R-15 is a non-mandatory language guide for the design and construction of structural concrete reinforced with FRP bars <sup>6</sup>. ACI is a leading authority for the development and distribution of standards and guidelines for buildings. ACI 440.1R-15 refers to buildings and cannot be enforced by building officials. For a guideline to become a standard, it must undergo a standardization process approved by the American National Standards Institute (ANSI).

For transportation structures, at the state level, the acceptance criteria are section 932 and 933 of the Florida Department of Transportation (FDOT) standard specifications for road and bridge construction <sup>26</sup>. The design reference standard for highway bridge constructions at the state level is the ‘Structures design guidelines for load and resistance factor design’ standard (SDG), issued by FDOT <sup>27</sup>. When dealing with highway transportation bridges built with federal funds, the designer must satisfy the requirements of the American Association of State Highway and Transportation Officials (AASHTO). Provisions related to limit state analysis, general design and location features, loads and load factors, structural analysis and evaluation shall be in compliance with “AASHTO LRFD Bridge Design Specifications” (AASHTO LRFD) <sup>28</sup>. “AASHTO LRFD Bridge Design Guide Specifications for GFRP Reinforced Concrete Bridge Decks and Traffic Railings” (AASHTO GFRP) <sup>29</sup> is a standard document containing provisions for the design and construction of concrete bridge decks and railings reinforced with GFRP bars.

ACI documents can be referenced in the design/construction transportation structures if not specifically addressed by AASHTO.

## **2.5 DESIGN REQUIREMENTS AND LOADS**

The AASHTO specifications <sup>28</sup> require highway bridges to be designed for constructability, safety, and serviceability, with due regard to issues of inspectability, economy, and aesthetics. Many aspects of the general requirements identified above are addressed in the form of limit states. The limit states specified in the AASHTO codes are intended to provide a buildable and serviceable bridge capable of safely carrying the design loads for the specified life span of 75 years. Four groups of limit states are specified to be used in the design of bridge elements: service, fatigue and fracture, strength, and extreme-event limit states. The Service Limit State is taken as restrictions on stress, deformation, and crack width under regular service conditions. The Fatigue and Fracture Limit State represents restrictions on the stress range due to a design truck with respect to fatigue and/or fracture failures seen as material cracking in bridge components. The Strength Limit State ensures that strength and stability are provided to resist the specified load combinations that a bridge component or system is expected to experience in the design life. The Extreme Event Limit State refers to the requirements for structural survival of the bridge component or system during a rare event, such as earthquake, significant flood, vessel collision, truck collision, ice flow, or scour condition. Bridge structures need to cover the effect of a variety of loads or actions. In the specifications, the load effects can be divided into two categories: permanent and transient <sup>28</sup>. The first group of permanent loads is dead loads. The dead load effect is treated in three

subgroups: dead load due to structural and nonstructural components (DC), dead load due to wearing surface and utilities (DW), and the down drag force (DD). Earth forces belong to another group of permanent loads. The AASHTO specifications identify EH, EV, and ES (horizontal, vertical and surcharge earth pressures). Transient loads are applied over a relatively short period of time, typically ranging from a few seconds to possibly several months. Truck related transient loads are denoted as LL for statically applied live load or vehicular load, IM for impact or dynamic effect of LL, BR for braking force of vehicle, CE for vehicular centrifugal force to a bridge horizontally curved, LS for vehicular-load-induced surcharge to substructure components through soil, WL for wind load on vehicles and thereby transferred to the structure, and CT for load effect of collision with a truck. LL is computed in design using the standard load specified in the, designated as HL-93 truck load and consisting of a combination of the design truck or design tandem (the greater of the two), and design lane load, as shown in Figure 2.4. The design lane load is a uniformly distributed load of magnitude 0.65 kips/ft (0.87 kN/m) over 10 ft length (3.05 m). Where the slab spans are primarily in the longitudinal direction, axle load or tandem load must be combined with the lane load. Where the slab spans primarily in the transverse direction, only the axles of the design truck or tandem shall be applied to the deck slab.

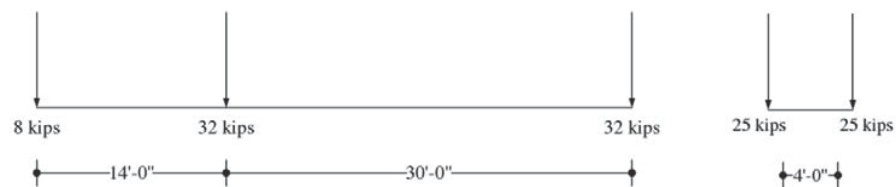

Figure 2.4 - HL 93 design truck loads: (a) Axle load, (b) Tandem load.

The non-vehicle related transient loads include, but are not limited to CR (creep induced forces), SE (settlement induced forced), SH (shrinkage related forces), EQ (seismic loads), IC (ice related loads), TG (temperature gradient related forces), TU (uniform temperature related forces), WS (wind loads on the structure), and PL (pedestrian induced live loads). The loads are combined with factors into limit states. A total of 13 limit states are required to be checked: 5 strength, 2 extreme event, 4 service and 2 fatigue limit states. The limit states differ for the value of the load factors ( $\gamma_i$ ), which are calibrated considering statistical data of the quantities involved, the risk and the importance of the bridge components.

## 2.6 ANALYSIS AND DESIGN

Load factor design (LFD) and service load design (SLD) are the two traditional design methods used in the United States for highway bridge design over many decades. Sometimes SLD is referred to as allowable stress design (ASD) in the literature. AASHTO<sup>28</sup> adopts the load and resistance factor design (LRFD) method since 1994. The LRFD method works to maintain the failure risk at an acceptable level, selecting resistance factors with the associated nominal loads and resistances. The load factors ( $\gamma_i$ ) vary depending on the situation to ensure safety. A typical design or evaluation process involves a significant amount of uncertainty. The sources of uncertainty include imperfect quality control causing variations in the dimensions of designed members, random fluctuation in member strengths, and unpredictably variable loads generating random effects in members being designed.

Figure 2.5 shows the procedure of reinforced bridge deck slab design. The first stage is the preliminary design. Highway bridge structures need to meet the requirements for the roadway<sup>28</sup>. The factors to be determined are width, length, number of spans, types of the spans (suspension, cable stayed, truss, arch, or beams, slab), material type (steel, concrete, composites etc.), construction method, and so on. After the preliminary design is completed, the second design stage is the detailed design. This stage includes determination of each member's dimensions, location, connection with other members, amount of reinforcement required and so on. The detailed design works toward the goal of a set of plans (shop drawings) for the contractor to build the bridge.

The structural analysis is performed to determine the design loads on the structure (shear, moments, axial loads and so on). The design loads are maximum effects that can be computed based on the elastic or plastic structural analyses. When applicable, approximate analysis methods are also available<sup>4</sup>. These actions are function of the dead and live load magnitudes and their distribution. The bridge designer is expected to choose the most appropriate method based on the degree of accuracy pursued. While a 2D analysis is commonly used in design to find the dead load moments and shears, 3D analysis can be more precise but also more costly in the analysis effort. The AASHTO specifications offer a table of wheel load effect based on 3D analysis results for a typical 1-ft strip as a function of beam spacing<sup>28</sup>.

The results of the structural analysis (design moments, shears, axial loads) are combined into limit states and implemented in the design and verification procedure. For short and medium-span highway bridges, the design process often follows the sequence

of (1) deck, (2) the deck-supporting system (beams, trusses, arches, etc.) if any, (3) bearings if any, (4) piers and/or abutments, and (5) foundations.

The first step after deriving the loads is the primary reinforcement design. In the case of slab bridges, the primary reinforcement runs parallel to the traffic direction, while girder bridges have the primary reinforcement transverse to the traffic direction. Shear, positive and negative moment factored resistances are verified at ultimate load conditions under the Strength 1 Limit State. The selected reinforcement requires to be checked against serviceability and fatigue conditions. Deflection and crack opening are verified under Service 1 limit state while fatigue and creep stress verification is performed under the Fatigue 2 load combination. Once the primary reinforcement has been successfully verified, the secondary reinforcement can be designed based on temperature and shrinkage induced effects. Moreover, the distribution reinforcement needs to be provided in the secondary direction to enforce uniformity of the load distribution on the structural element.

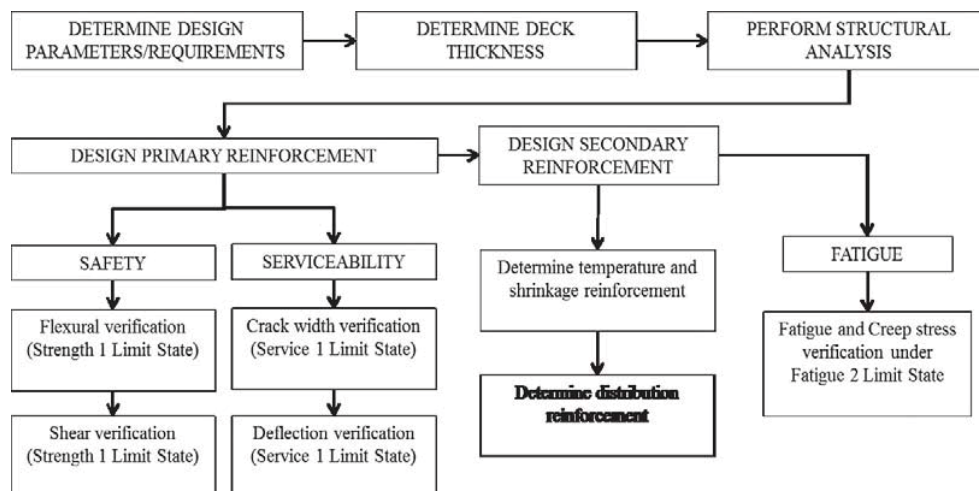

Figure 2.5 - Design procedure for GFRP RC bridge components.

In this study the design of a GFRP RC solid deck and GFRP RC pile cap are described. GFRP-RC girders and piles are disregarded from the design, since they are not an efficient way to use the GFRP bars as internal reinforcement. In fact, these structural components are usually prestressed. GFRP bars are not suitable for pre-tension loads due to creep rupture. Stress levels have to be limited to 20 percent of the design strength of the reinforcement to avoid rupture under sustained and cyclic stresses<sup>29</sup>. Ordinary high strength, low relaxation steel can sustain up 70% of its design strength, providing around ten times the allowable GFRP prestress, in the case of commercially available 7 wire strands (1800 MPa tensile strength).

A change in the design philosophy of steel RC members is required when dealing with GFRP RC structures. Although it does not corrode like steel, GFRP reinforcement may degrade with age. To account for this possibility, ACI 440.1R-15<sup>6</sup> prescribes the use of an environmental coefficient in design equations. A 70 percent reduction on the ultimate tensile strength accounts for the aging of GFRP exposed to extremely aggressive environmental conditions during its working life<sup>29</sup>.

GFRP bars in compression do not increase the strength nor reduce the effects of concrete creep of GFRP RC flexural members due to the limited compressive strength and modulus of the GFRP bars<sup>4</sup>. For this reason, design standards presently do not recommend relying upon compression GFRP reinforcement in flexural members<sup>29</sup>.

The behavior of GFRP RC members is affected by the presence of reinforcement that does not yield and is to be considered linear-elastic up to failure. As opposed to traditional RC structures, where failure is always controlled by crushing of the concrete after yielding of the steel, members reinforced with GFRP bars may display either concrete

crushing or GFRP rupture as the governing failure mode<sup>4,6</sup>. When concrete crushing and GFRP rupture occur simultaneously, failure is balanced. The position of the neutral axis corresponding to balanced failure is used as the basis to establish the member failure mode. When the position of the neutral axis at ultimate,  $c$ , is larger than  $c_b$ , the failure is controlled by the crushing of the concrete; conversely, when  $c$  is less than  $c_b$ , the failure is initiated by rupture of the GFRP reinforcement. When failure is initiated by the crushing of the concrete ( $c > c_b$ ), the stress distribution in the concrete can be approximated with the equivalent rectangular stress block<sup>4</sup>. The position of the neutral axis can be determined and the nominal moment resistance can be calculated. When failure is initiated by rupture of the GFRP reinforcement ( $c < c_b$ ), the compressive strain in the concrete has not reached the ultimate value  $\epsilon_{cu}$ <sup>4</sup>. Since a closed-form solution is impractical, a numerical procedure may be adopted by assuming tentative values for the neutral axis depth,  $c$ , until the equilibrium condition is satisfied<sup>4</sup>. Once the position of the neutral axis,  $c$ , is known, the nominal bending moment capacity can be calculated. Available standards and guidelines on concrete members reinforced with GFRP bars allow for the use of simplified approaches to compute the bending moment capacity with little loss in the accuracy of the final result<sup>6,29</sup>.

The lack of yielding of the GFRP reinforcement that produces an overall less ductile behavior of GFRP RC members as compared to steel RC members must be compensated for with an increase in the safety factor used for design<sup>4</sup>. This increased safety can take the form of more stringent strength-reduction factors or larger material safety. When the area provided is less than the one necessary to produce a balanced collapse condition ( $\rho_f \leq \rho_b$ ), failure is initiated by the rupture of the GFRP reinforcement; if  $\rho_f > \rho_b$  (or better,  $\rho_f >$



1.4  $\rho_b$ ), failure is controlled by crushing of the concrete. The corresponding  $\phi$ -factors are 0.55 and 0.65, respectively, and there is a linear transition between the two failure modes<sup>6, 29</sup>.

One of the main assumptions at the basis of reinforced concrete mechanics is a “perfect” bond between the reinforcing bars and the surrounding concrete. Therefore, adequate embedment length of the GFRP reinforcement is required to avoid bond failure. The development length,  $l_d$ , is the bond length necessary to develop the effective stress of the bar in tension ( $f_f$ )<sup>29</sup>.

The shear capacity of the member is a function of the member geometry, the spacing of the reinforcement and the mechanical properties of the materials. When using GFRP as shear reinforcement, one needs to recognize that GFRP has a relatively low modulus of elasticity, tensile strength of the bent portion of an GFRP bar is significantly lower than the straight portion, and GFRP has low dowel resistance<sup>4</sup>. The nominal shear strength of a member,  $V_n$ , is the sum of the contributions of concrete,  $V_c$ , and FRP reinforcement,  $V_f$ . ACI 440.1R-15<sup>6, 29</sup> states that the strength-reduction factor of 0.75 given by ACI 318-14 for reducing nominal shear capacity of steel-reinforced concrete members should also be used for FRP reinforcement<sup>30</sup>.

The serviceability limit states for GFRP reinforced concrete flexural members generally include crack width, maximum deflections, and maximum stress levels to avoid GFRP creep-rupture and fatigue. In many instances, serviceability criteria (crack width and deflections) may control the design because of the relatively smaller stiffness of these members after cracking<sup>4</sup>.

Crack width in GFRP reinforced concrete is generally limited for aesthetic reasons and to prevent water leakage. Differently from the case of steel reinforced concrete, crack width limitations related to the potential corrosion of the reinforcement are not required for GFRP reinforced concrete. GFRP bars are corrosion resistant; therefore, larger crack widths as compared to steel reinforced concrete can be tolerated when corrosion of the reinforcement is the primary reason for crack control <sup>4</sup>.

Deflections in RC slabs and beams are generally limited to prevent damage to nonstructural or other structural elements and to avoid disruptions of function. The control of deflections consists in verifying that the sum of the immediate deflections due to the loads and the long-term deflection due to creep and shrinkage is smaller than a limiting value <sup>29</sup>. The immediate deflections are generally computed including live loads only, whereas the long-term deflections are computed including the dead loads and a percentage (typically 20 percent) of the live loads <sup>28</sup>. Calculations are shown in Appendix A.

Sustained loads can cause GFRP to fail suddenly after a period of time defined as the endurance time. This phenomenon is known in literature as creep rupture (or static fatigue). AASHTO recommends limiting the stress level in the GFRP reinforcement induced by sustained loads (dead loads and the sustained portion of the live load) to prevent creep rupture <sup>29</sup>. The stress level in the FRP can be computed using the Navier equation and is shown in Appendix A.

Shrinkage and temperature reinforcement is intended to limit crack width. Stiffness and strength of reinforcing bars control this behavior <sup>4</sup>. Shrinkage cracks perpendicular to the member span are restricted by flexural reinforcement; therefore, reinforcement in

only required in the direction perpendicular to the span. No experimental data are available in the technical literature to establish the minimum GFRP reinforcement ratio for shrinkage and temperature. Accordingly, the same equation adopted from ACI 318-14<sup>30</sup> is proposed by ACI 440.1R-15<sup>6</sup>.

## **2.7 FDOT LRFD#2A DESIGN EXAMPLE**

FDOT provides guidance for the design of steel RC bridge components with the document “LRFD Design example #2: cast-in-place flat slab bridge design” (FDOT LRFD#2A), available in the FDOT website. The example adopts the Load and Resistance Factor Design (LRFD) method for the design of deck and pile caps.

The given example has been modified to account for the properties of GFRP reinforcement. Algorithms and standard procedures have been implemented to allow for the design of GFRP RC flat slab, pile caps and traffic barriers. Considerations related to traffic barrier design are described in Study 2. Finally, the FDOT LRFD #2A design example reported in Appendix A has been created in collaboration with the University of Miami CAE Department and delivered to FDOT. The new document has been developed in MathCad language to allow bridge designers and transportation officials to alter input variables and material parameters creating a customized application. The program performs automated verification of the bridge components comparing the factored strength with the design actions according to AASHTO and FDOT provisions.

The example presented in Appendix A is a 105 ft (32 m) long and 89.1 ft (27.1 m) wide concrete slab bridge. The primary reinforcement runs parallel to the traffic direction, while the secondary reinforcement is orthogonal to the traffic direction, with a

skew angle of 30 degrees. The deck thickness is 18 in (457 mm) and the concrete cover is set to 1.5 in (38.1 mm) for all the GFRP RC elements, being corrosion not an issue for GFRP. Two expansion joints with maximum width of 2 in (50.8 mm) are located in the approaching slabs to accommodate movements induced by creep, shrinkage and temperature fluctuations. The concrete characteristic compressive strength is 4,500 psi (31 MPa) for deck and traffic barrier, 5,500 psi (38 MPa) for pile caps and 6,000 psi (41 MPa) for prestressed concrete piles. Four intermediate supports are provided each 35 ft (10.7 m) and 10 square piles spaced 11 ft (3.35 m) center-to-center are embedded 12 in (0.3 m) into the cap at each support location. The pile cap is 102.86 ft (31.3 m) long, 3.5 ft (1.07 m) wide and 2.5 ft (0.76 m) deep. The loads acting on the structure are the self-weight of the deck, the load of the wearing surface (15 psf or 0.72 kN/m<sup>2</sup>), the self-weight of the traffic barriers (421 plf or 6.2 kN/m) and median barrier (486 plf or 7.2 kN/m), the vehicular live load due to HL-93 design truck. For the dead load calculation, the influence line coordinates for a uniform load applied on the structure is utilized. The influence coordinates are based on AISC's Moments, Shears and Reactions for Continuous Highway Bridges. In order to calculate the live load moments and shear forces, the FDOT MathCad program "LRFD Live Load Generator, English, v2.1" has been used. The design live loads consist of the HL-93 vehicle moments, divided by the appropriate equivalent strip widths. The superstructure is designed on a per foot basis longitudinally and the results of the structural analysis are combined into limit states to verify the capacity of the designed components. The primary reinforcement necessary to enforce strength, serviceability and fatigue resistance in the central region of the deck is a No 10 bar (32 mm diameter) spaced 4 in (0.1 m) center-to center with the next bar, at the

top and bottom layer. In the edge region the primary reinforcement consists of 2 No 10 bars (two 32 mm diameter bars) bundled with a 6 in (0.15 m) couple-to-couple spacing, in the top and bottom layers. The secondary reinforcement consists of No 6 bars (19 mm diameter) spaced 6 in (0.15 m) at the bottom and 12 in (0.3 m) at the top. The cap longitudinal reinforcement is 12 No 10 bars (twelve 32 mm diameter bars) for the positive and negative moment region. The transverse reinforcement is a set of 4 No 4 U bent bars (13 mm diameter) spaced 9 in (19 mm) center-to. All the supporting design calculations are reported in Appendix A.

## **2.8 CR490A BRIDGE OVER HALLS RIVER**

In 2014 FDOT decided to replace the existing bridge number 024054 over Halls Rivers on state roadway CR490A, Citrus County, Florida. The bridge spans 185.83 ft (56.6 m) over water and is 59.81 ft (18.2 m) wide. The traffic flows with two travel lanes per direction and pedestrian lanes 5 ft (1.52 m) wide are provided at in the edge region of the bridge. The program consists in a two-phase demolition and replacement stages. The new structure is a concrete girder bridge supported by two abutments and five piers. The deck primary reinforcement runs perpendicular to the traffic direction, while the secondary reinforcement runs along the span of the bridge. FDOT choice was to replace steel with GFRP bars to reinforce the cast-in-place slab. The deck is 8 in (203 mm) thick with a clear cover of 1.5 in (38 mm), being corrosion not an issue for GFRP. The deck is supported by a hybrid composite of beams (HCB) spaced 5.25 ft (1.6 m) center-to-center. The HCB elements are comprised of three main sub-components that are the shell, compression reinforcement and tension reinforcement. The first of these is the GFRP

beam shell, which encapsulates the other two subcomponents. The second major sub-component is the compression reinforcement which consists of portland cement grout or concrete which is pumped or pressure injected into a continuous conduit fabricated into the beam shell. The third major sub-component of the beam is the tension reinforcement, which is used to equilibrate the internal forces in the compression reinforcing. This tension reinforcing could consist of unidirectional carbon, glass or steel. The composite beams are self-supporting prior to and during the installation of the compression reinforcement. The pier caps are 57 ft (17.4 m) long, 3 ft (0.91 m) deep and 4 ft (1.22 m) wide. Six prestressed precast square concrete piles are embedded 12 in (0.3 m) into the cap to enforce continuity between the components.. Two expansion joints are located in the approaching slabs to accommodate movements induced by creep, shrinkage and temperature fluctuations. The concrete characteristic compressive strength is 5,500 psi (38 MPa) for barriers, deck and pile caps, and 6,000 psi (41 MPa) for prestressed concrete piles. The loads acting on the structure are the self-weight of the deck, the self-weight of the traffic barriers (420 plf or 6.2 kN/m) and pedestrian railings (30 plf or 0.4 kN/m), the vehicular live load due to HL-93 design truck. For the dead load calculation, the influence line coordinates for a uniform load applied on the structure is utilized. The influence coordinates are based on AISC's Moments, Shears and Reactions for Continuous Highway Bridges. In order to calculate the live load moments and shears, the FDOT MathCad program "LRFD Live Load Generator, English, v2.1" has been used. The design live loads consist of the HL-93 vehicle moments, divided by the appropriate equivalent strip widths. The superstructure is designed on a per foot basis longitudinally and the results of the structural analysis are combined into limit states to verify the

capacity of the designed components. The primary reinforcement necessary enforce strength, serviceability and fatigue resistance in the deck is a No 6 bar (19 mm diameter) spaced 5 in (0.13 m) center-to center with the next bar, at the top and bottom layer. The secondary reinforcement consists of No 6 bars (19 mm diameter) spaced 6 in (0.15 m) in the bottom layer. No secondary reinforcement is necessary in the top layer of the deck. The most relevant drawings are reported in Appendix B and the reference design document is reported in Appendix C.

## **2.9 UNIVERSITY OF MIAMI PEDESTRIAN BRIDGE**

In November 2014 the University of Miami applied for the permit to realize a pedestrian bridge at the center of its Coral Gables campus. The 210-foot-long (64 m) bridge over Lake Osceola would connect parking and housing areas to a performance stage in the university's renovated student center complex. The bridge, from near Eaton Residential College to the lakeside patio stage, is part of the university's mobility plan to promote more walking. The program includes the construction of two vehicular and one pedestrian bridge. According to the permit application, the entirety cost of the construction, which includes work with the canals, will cost \$1 million. The construction of the pedestrian bridge started in May 2015, after commissioners approved the permit.

After producing the first set of structural drawings, the designer opted to change the deck reinforcement from steel to GFRP bars. The drawings in Appendix C refer to the steel reinforced version of the deck, while the design calculations account for the GFRP RC version.

The total length of the bridge is 210 ft (64 m) and 13.8 ft (4.2 m) wide. It consists of three spans 65 ft (19.8 m) long and a 15 ft (4.6 m) overhang connecting the new structure with the existing concrete platform. The superstructure is a composite system of steel girders and tapered concrete beams. Two primary W36x52 (914.4 mm deep double tee) beams run along the spans welded to secondary W36x135 (914.4 mm deep double tee) beams. The substructure consists of three intermediate reinforced concrete pile caps 13.8 ft (5.7 m) wide, 7.2 ft (2.2 m) long and 3 ft 0.9 m) deep an abutment end support 6.5 (2 m) ft long, 13.8 ft (4.2 m) wide 5.7 ft (1.7 m) deep. Four square prestressed concrete piles 14'x14' (356x356 mm) are embedded into the caps, while the abutment is sustained by three concrete piles with the same properties. The concrete clear cover is 2 in (51 mm) at the top and 1.5 in (38 mm) at the bottom. Concrete strength is 5,000 psi (34.5 MPa).

Bridge deck is a 6 to 6.75 in (152 to 171 mm) thick concrete slab with longitudinal (parallel to the traffic direction) and transverse (perpendicular to the traffic direction) reinforcement in the bottom and top layers. The longitudinal reinforcement are No 5 (16 mm diameter) steel bars at 6 in (0.15 m) at the top and No 4 (13 mm diameter) steel bars at 6 in (0.15 m) at the bottom. The transverse reinforcement spans 5.5 ft (1.68 m) between the two tapered beams and consists of No 4 GFRP bars (13 mm diameter) at 6 in (0.15 m) at the top and No 3 (9 mm diameter) GFRP bars at 12 in (0.3 m) in the bottom layer. Since the edge portion of the bridge is very stiff the design loads have been computed assuming a fixed-fixed beam static scheme. The ultimate moment under strength 1 limit state is 0.78 kips-ft (1.07 kN-m) including dead load (slab and railings self-weight) and pedestrian live load (100 psf or 4.84 kN/m<sup>2</sup>), while the service moment is 0.43 kips-ft (8 kN/m<sup>2</sup>). No composite action between the steel girders and the concrete



slab have been taken into account in the design calculations. The factored flexural strength at support is 0.43 kips-ft (0.6 kN-m) and 1 kip-ft (1.37 kN-m) at middle span. Both ultimate and serviceability requirements are met with the designed reinforcement. The supporting calculations are reported in Appendix C.

## **2.10 FUTURE RESEARCH DIRECTIONS**

GFRP reinforcement can be advantageous for use in bridge engineering under certain circumstances. However, significant margins exist to advance GFRP RC technology by addressing issues related to aspects of the manufacturing and construction process. Concerns are present due to the limited information available on material system's recyclability, environmental and health impacts<sup>54</sup>. (1) Recyclability: fibers and resins are considered hazardous materials to workers and its controlled disposal requires protocols not common in the construction industry, with limited available information<sup>55</sup>. (2) Environment and health: research and development efforts to study the environmental and health impacts of GFRP material systems are limited<sup>56</sup>. (3) Cost: researching alternatives to reduce the initial cost is essential for the acceptance of this technology<sup>54</sup>. The studies performed to evaluate the cost efficiency and environmental impact of bridges utilizing GFRP compared to conventional bridge designs are very limited<sup>57, 58, 59</sup>. Therefore, there is a need to assess the environmental and health effects of internally applied GFRP systems and associated life cycle costs. Providing designers and project owners with appropriate tools for decision-making is a key step. At present, a few tools have been developed; however, several of these are insufficient for the challenges of environmental decision-making. Thus, future efforts in the development of decision-

support tools are necessary integrating holistic approaches that consider costs and environmental impacts in a life-cycle perspective. LCA/LCC tools need to be developed to facilitate designers to perform calculations of the environmental impacts and life cycle costs; and to compare the impacts and costs of alternative designs. In order to raise the decision makers' trust in the result of LCA and LCC, data provided should evaluate availability and reliability. The outputs can calculate results for different stages in the life cycle of a building, including up to the as-built stage, the operating stage and the end-of-life stage.

## **2.11 CONCLUSIONS**

The use of GFRP reinforcement in elements of bridge structures has high potential for reducing the problem of deterioration of bridge structures as a result of corrosion of reinforcement. However, GFRP reinforcement cannot be used as a direct replacement for steel because of the significantly different mechanical properties. Ductility of steel is the fundamental property that allows the design of RC structures that behave in a ductile manner. With the use of GFRP, both concrete crushing and reinforcement rupture are possible failure modes. In any case, the member does not exhibit ductility as for steel reinforced members. In the case of GFRP rupture, failure of the member is sudden and catastrophic. However, there would be warning of impending failure in the form of extensive cracking and large deflections due to significant elongation that GFRP experience before failure. Compression controlled behavior is marginally more desirable for flexural members. By experiencing concrete crushing, a flexural member does exhibit

some inelastic behavior before failure. Both compression and tension controlled approaches are acceptable, provided that strength and serviceability criteria are satisfied. To compensate for the lack of ductility, the member must possess higher reserve of strength.

This study re-explored the basic concepts related to bridge and GFRP RC design. The procedure is implemented in three case studies demonstrating the viability of GFRP as internal reinforcement for concrete cast-in-place decks and pile caps in highway bridge structures.

## **CHAPTER 3**

# **STUDY 2 \_SAFETY-SHAPED CONCRETE RAILINGS AND TRAFFIC BARRIERS USING GFRP REINFORCEMENT**

### **3.1 SUMMARY**

Until recently, most traffic barriers using GFRP bars were vertical-faced systems. However, the impact time duration of vertical-faced barriers is shorter causing higher peak forces to be transferred to vehicle occupants. Nowadays, GFRP manufacturers can produce standard bar bends which can be used for the reinforcement of safety-shaped concrete railings and barriers. The implementation of GFRP bar bends requires some changes in the current design philosophy for railings and barriers.

Whereas the overall goal of the research program is to make the technology of concrete bridge reinforcement with composites available to bridge owners and professionals, this study provides the principles for the design of safety-shaped GFRP reinforced concrete railings and barriers. In this chapter the effectiveness of a simple method to determine the design strength of GFRP RC corner joints subjected to impact loads is demonstrated.

### 3.2 BACKGROUND

Bridge railings and traffic barriers must contain and redirect errant vehicles while preventing rollover and snagging, and allowing deceleration to a stop at a relatively short distance from the impact section. The high force levels developed redirecting a vehicle are faced using strong, rigid barriers. Most concrete barrier shapes evolved from a barrier developed by General Motors and referred to as the GM shape. The barrier incorporates a shallow lower slope and a steep upper slope. During low angle impacts, the tires climb the lower slope and redirect the vehicle without any sheet metal contact with the barrier. The upper slope serves to redirect vehicles impacting at higher angles.

The GM shape and all of its descendants are called safety shaped barriers. Figure 3.1 shows the GM shape along with the other concrete barrier shapes which have evolved from it. In the late 1950's and early 1960's the New Jersey State Department of Transportation developed what came to be called the New Jersey shape concrete barrier through years of crash testing and shape consideration <sup>31</sup>. The New Jersey shape contains a 55 degree lower slope similar to the GM shape, but the height of the lower slope was reduced from 330 mm (13 in) to 254 mm (10 in). The lower step of the barrier allows impact forces to act throughout the time the vehicle travels over the step and deeper into the barrier. This extended time results in lower peak impact forces and reduced accelerations for the passengers than the shorter interval associated with a flat wall <sup>32</sup>. However, tire climb on the barrier face creates negative effects as well. At high impact angles, tire climb can induce high vehicular roll angles.

The F-shape barrier was designed to reduce the amount of vehicle climb and roll through a parametric study of the basic New Jersey shape. Constant slope barriers were developed to further increase vehicle stability by eliminating the lower slope of the New Jersey and F-shape barriers. Vehicle stability is greatly improved for constant slope barriers in comparison to the previous safety shapes. Single-slope barriers include the California Type 60 barrier and the Texas SSCB. These barriers incorporate angles of 9.1 and 10.8 degrees from vertical, respectively. A significant amount of wheel climb is still prevalent during impacts and may lead to vehicle instability problems, such as rollovers.

The optimum barrier shape for vehicle stability is a vertical face. Impact forces act normal to the barrier face, so for a vertical wall, the forces are completely horizontal. However, by limiting vehicular movement, the impact time duration is shorter causing higher peak impact forces <sup>32</sup>. These higher peak impact forces transfer to the vehicle occupants and lead to an increased risk of injury. Vertical face barriers can also create a problem with head slap. Head slap occurs when the lateral impact forces cause the passenger's head to be ejected through the side window of the vehicle and contact the barrier or attachments to the barrier. Head slap greatly increases the risk of serious injury and fatality during impacts.

All of these standard barrier shapes have some negative aspects. Both safety-shaped barriers and single-sloped barriers induce vehicle climb that leads to rollover. Vertical shaped barriers prevent vehicle climb, but can cause head slap for barriers taller than the bottom of a vehicle's window. For the given study, the most common type of traffic barrier in the state of Florida has been chosen.

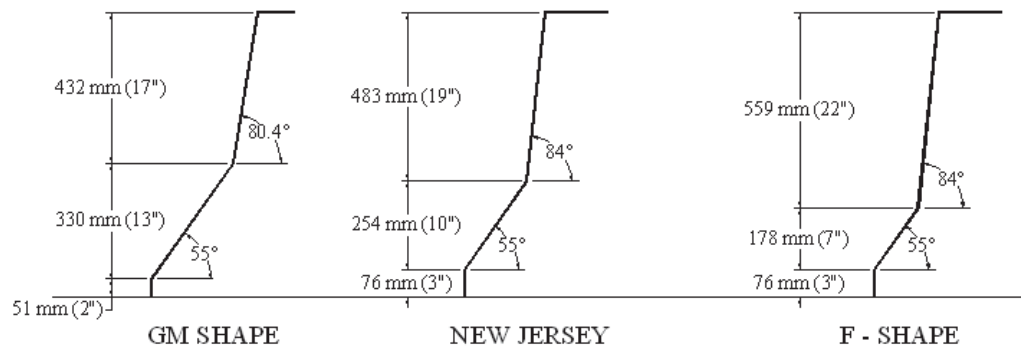

Figure 3.1 (a) - Safety shaped concrete barriers.

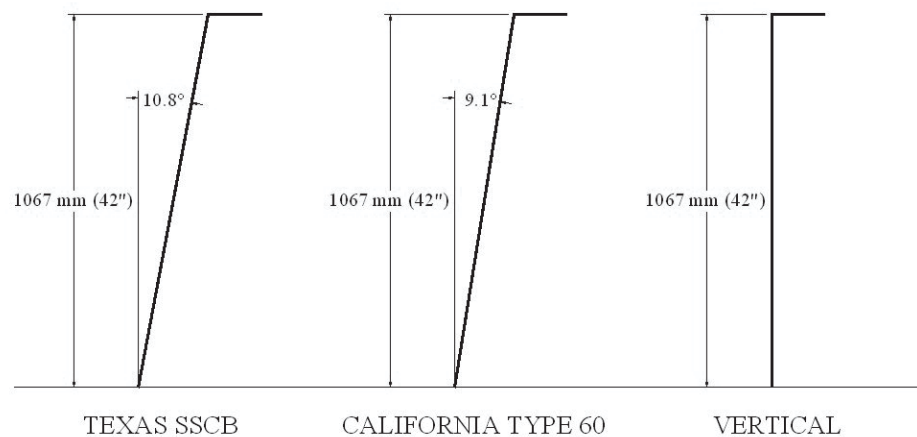

Figure 3.1 (b) - Constant slope concrete barriers.

### 3.3 DESIGN LOADS

Crash testing of bridge traffic barriers aims to assess both the structural and geometrical crashworthiness, depending on the level of service sought. Variations in traffic volume, speed, vehicle mix, roadway alignment, activities and conditions beneath a structure, and other factors combine to produce a vast variation in traffic railing performance requirements. The primary purpose of traffic railings is to contain and redirect vehicles using the structure. All new vehicle traffic barrier systems, traffic

railings, and combination railings must be structurally and geometrically crashworthy. Consideration should be given to protection of the occupants of a vehicle in collision with the railing, protection of other vehicles near the collision, protection of persons and property on roadways, possible future rail upgrading, railing cost-effectiveness, and variations in traffic volume and other factors <sup>28</sup>.

Since 1993, National Cooperative Highway Research Program (NCHRP) Report 350 <sup>33</sup> has provided the standard for evaluating roadside safety devices. NCHRP Report 350 not only guides crash testing procedures and impact conditions for barriers and crash cushions, but also describes the criteria in which each test is evaluated. The report divides barriers into six different test levels, TL-1 through TL-6, with the severity and impact loading increasing with each level. One of the following test levels should be specified:

- TL-1(Test Level One): generally acceptable for work zones with low posted speeds and very low volume, low speed local streets.
- TL-2 (Test Level Two): generally acceptable for work zones and most local and collector roads with favorable site conditions as well as where a small number of heavy vehicles is expected and posted speeds are reduced.
- TL-3 (Test Level Three): generally acceptable for a wide range of high-speed arterial highways with very low mixtures of heavy vehicles and with favorable site conditions.
- TL-4 (Test Level Four): generally acceptable for the majority of applications on high speed highways, freeways, expressways, and Interstate highways with a mixture of trucks and heavy vehicles.



- TL-5 (Test Level Five): generally acceptable for the same applications as TL-4 and where large trucks make up a significant portion of the average daily traffic or when unfavorable site conditions justify a higher level of rail resistance.
- TL-6 (Test Level Six): generally acceptable for applications where tanker-type trucks or similar high center of gravity vehicles are anticipated, particularly along with unfavorable site conditions.

Traffic barriers are at least 27.0 in (0.69 m) for TL-3, 32.0 in (0.81 m) for TL-4, 42.0 in (1.07 m) for TL-5, and 90.0 in (2.23 m) in height for TL-6<sup>28</sup>. The forces to be transmitted from the bridge railing to the bridge deck may be determined from an ultimate strength analysis of the railing system. The individual tests are designed to evaluate one or more of the principal performance factors of the bridge railing, which include structural adequacy, occupant risk, and post-impact behavior of the test vehicle. The dynamic loads imparted by an impacting vehicle under specified crash test conditions<sup>34</sup> are translated by AASHTO into equivalent factored static loads (transverse,  $F_t$ , longitudinal,  $F_l$ , and vertical,  $F_v$ ) to be used for structural design (Figure 3.2). These loads refer to extreme limit state conditions. Serviceability requirements are not a major concern for barrier design. In the case of concrete railings designed to resist  $F_t$ , the effects of  $F_l$  and  $F_v$  are generally relevant for design purposes. In fact, the transverse load is typically the one of concern for RC railing structures.

Design Forces and Designations	Railing Test Levels					
	TL-1	TL-2	TL-3	TL-4	TL-5	TL-6
$F_T$ Transverse (kips)	13.5	27.0	54.0	54.0	124.0	175.0
$F_L$ Longitudinal (kips)	4.5	9.0	18.0	18.0	41.0	58.0
$F_V$ Vertical (kips) Down	4.5	4.5	4.5	18.0	80.0	80.0
$L_T$ and $L_L$ (ft)	4.0	4.0	4.0	3.5	8.0	8.0
$L_V$ (ft)	18.0	18.0	18.0	18.0	40.0	40.0
$H_e$ (min) (in.)	18.0	20.0	24.0	32.0	42.0	56.0
Minimum $H$ Height of Rail (in.)	27.0	27.0	27.0	32.0	42.0	90.0

Figure 3.2 - Design Forces and dimensions for Traffic barriers and railings.

### 3.4 STATE OF THE ART: GFRP RC RAILINGS AND BARRIERS

A number of field implementations in North America have demonstrated the validity of GFRP reinforcement for traffic barriers. Some of these experiments are part of research projects. The first application of GFRP reinforced traffic barriers are open post-rail types. In 2003, El-Salakawy et al. <sup>35</sup> conducted an experimental investigation on continuous GFRP RC barriers that were subjected to out-of-plane (transverse) static and pendulum impact loads. Full-scale GFRP RC deck-barrier subassemblies were designed such that the reinforcement had an equivalent strength compared to that of the steel RC counterparts. The test results showed a similar behavior at failure of both steel and GFRP RC systems, and the latter solution was approved by the Ministry of Transportation of Québec (MTQ). Following this, two research bridges were constructed with GFRP-RC decks and barriers in Québec on Highway 20 in 2004 (Val-Alain) and Highway 55 in 2005 (Melbourne), where GFRP RC barriers with a performance level of 2 (TL-2) and 3 (TL-3) respectively <sup>36</sup> were used <sup>37</sup>.

The crashworthiness of an open-post railing internally reinforced with GFRP bars, which was developed for use in highway bridges, was assessed through two crash tests<sup>38</sup>,

as per the NCHRP Report 350<sup>33</sup>. The TxDOT Project 9-1520, “FRP Reinforcing Bars in Bridge Decks,” was initiated in August 1999. This was a joint project involving the Texas Transportation Institute, the University of Texas at Arlington, and Texas Tech University. The barrier consisted of concrete bridge rail supported by concrete posts spaced 5 ft (1524 mm) apart. Structural adequacy of the rail was demonstrated in both tests. Collision loads imposed on the bridge rail were readily resisted (Figure 3.3). Consequently, structural failure modes for the bridge rail with GFRP reinforcement were not identified in the full-scale crash tests. The TxDOT T202 with GFRP reinforcement contained and redirected the pickup truck. The vehicle did not penetrate, under-ride, or over-ride the bridge rail. No measurable deflection was noted.

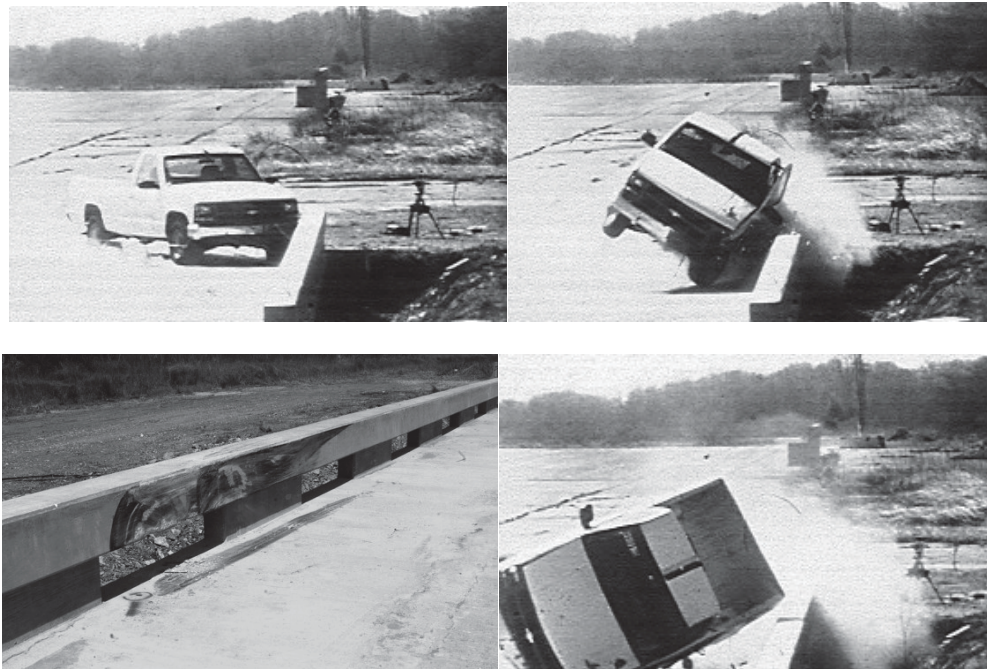

Figure 3.3 - Sequential Photographs for Test 441382-1.

In 2003, the owner of Bridge 14802301 in Greene County, Missouri, USA, opted for the replacement of the original 70-year old slab-on-girder superstructure. A two-year research and development and technology transfer project culminated with the accelerated construction of this off-system bridge, where only prefabricated GFRP reinforcement was used for the RC deck and open-post railings (Figure 3.4)<sup>39</sup>. The five-day re-decking was completed with a reduction in construction time (and labor cost) of over 70 percent compared to conventional processes. The cost estimate for the railings was \$271/m. The work was completed in November 2005 (Appendix E).



Figure 3.4 - Reconstruction of Bridge No. 14802301 (a) GFRP reinforcement cages prior to casting of railing, (b) open-post railing in service.

Steel post-and-beam barrier systems with the curb and adjoining bridge deck reinforced with GFRP bars in lieu of steel bars have been investigated<sup>40</sup>. RC prototypes were designed using an equivalent amount of reinforcement compared with the steel RC system. Open GFRP stirrups to connect the curb to the deck slab were used. The transverse strength of the GFRP RC systems largely exceeded the equivalent code-

mandated static load demand and is on average similar to that of the steel RC system. (Appendix E). Vertical-faced barriers were used for the rehabilitation of John Street CNR Overhead Bridge, Ontario, 2012 (Appendix E) <sup>41</sup>. The transverse reinforcement consisted of couples of straight bars connected to the longitudinal reinforcement. The vertical bars were embedded in the concrete of the deck before casting. The same layout and procedure was applied for the replacement of Adjala-Tosorontio Bridge <sup>42</sup>.

In the case of Boulevard West Bridge in Lakeshore, 2013, the transverse reinforcement is a straight bar coupled with a 90 degree bent bar, used to increase the bond between the bridge deck and the barrier <sup>43</sup>. Another method to connect the parapet to the superstructure is by means of a pair of GFRP U bent bars, joined to form a close loop. One of the bars is connected to the deck reinforcement and after casting, the other bar is coupled with a lap splice. This system was used in Eglinton Avenue Bridge, in Toronto, Canada, 2009 <sup>44</sup>.

Safety shaped parapets (GM, New Jersey, F types) reinforced with GFRP bars have been employed in different recent projects. The first application has to be viewed as a transition from vertical face parapet to enhanced shape parapets. In Clark's Mill Bridge, 2007, Canada, GFRP straight bars are used for transverse reinforcement (appendix E). The GFRP reinforcement is connected to the deck by a 22 mm (0.87 in) double head galvanized steel with 0.3 m (11.8 in) spacing <sup>45</sup>. Splicing GFRP and steel bars with adequate detailing, stresses are transferred from the parapet to the rest of the bridge superstructure during the impact.

The Ross Corner Bridge traffic Barriers, 2011 <sup>46</sup> (Appendix E) uses a double bent GFRP bar and a 90-degree bent bar. Both bars are connected to the deck reinforcement.

Another 90-degree bent bar is placed after casting the deck, and connected to the vertical bars and longitudinal reinforcement.

A similar method was used in the rehabilitation of the Baden Creek Bridge, 2007. Three different types of bent bars were used to optimize the conformation to the shape of the parapet. All the bars are embedded into the deck, providing anchorage at the deck to parapet interface <sup>47</sup>. As another example, safety-shaped barriers reinforced with GFRP bars were used in Canada for the rehabilitation of Tenth Line Bridge, 2012 <sup>48</sup>.

### **3.5 GEOMETRY DEFINITION AND REINFORCEMENT LAYOUT**

The type of safety-shaped barrier for this case of study has been chosen as a representation of common application in the State of Florida. The type of safety-shaped traffic barrier selected is the New Jersey Shape Railing, 32 in (813 mm) in height, according to Florida Department of Transportation (FDOT) provisions <sup>26</sup> (Figure 3.5). The concrete clear cover is set at 1.5 in (38 mm), instead of 2 in (51 mm), as for the correspondent steel RC, being corrosion not an issue for GFRP reinforcement. Due to height requirements, the maximum level of resistance achievable is Test Level 4 (TL-4), which corresponds to a maximum resistance of 54 kips (243 kN) against transverse impact loads. The minimum resistance is 13.5 kips (60.75 kN) for TL-1. The GFRP reinforcing bars must satisfy the AC454 minimum requirements. The spacing between the barrier bars is imposed by the impact force and must consider the deck reinforcement spacing. The bars are tied to the top and bottom layers of the deck reinforcement to guarantee continuity between barrier and deck. Commercially available GFRP bars can

be bent only during the manufacturing process. Development and splice length determines the size and geometry of the reinforcement. Their dimensions depend on the stress level, as well as surface area. Bar nominal size can vary between No 4 and No 8 (12.7 mm and 25.4 mm diameter) for transverse reinforcement. Different bar sizes are excluded for constructability reasons (e.g. high bend radius, high development and splice length). The transverse reinforcement consists in a pair of bent bars connected to the deck reinforcement before pouring the concrete. Appendix E shows the detailing of the reinforcement layout and its assembly.

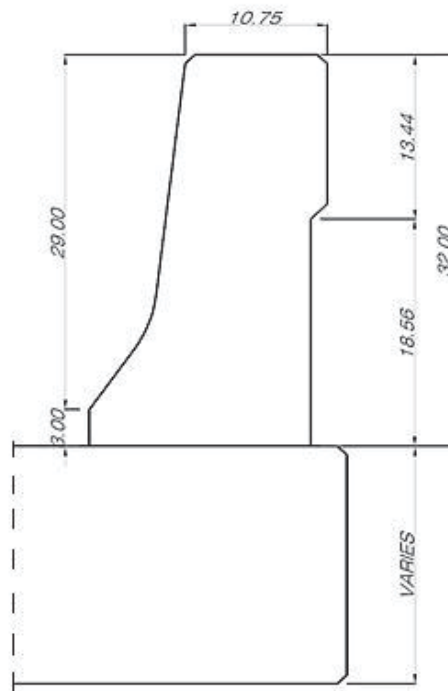

Figure 3.5 Barrier geometry used for the design example: FDOT 2014 “Section Thru New Jersey Shape Railing”, 32 in in height (units in in.; 1 in. = 25.4 mm).

### 3.6 ANALYSIS AND DESIGN

In 1978, Hirsch <sup>49</sup> developed a method to calculate the structural capacity of a highway barrier utilizing the yield line theory. This type of analysis predicts the ultimate strength of the barrier using the conservation of energy principle and an estimated failure shape. Upon postulation of a failure mode in the form of a kinematically admissible collapse mechanism that satisfies the yield criterion at the yield lines, an upper-bound ultimate load is determined by equating the work done by the external load and the resisting forces. Hence, in case of statically indeterminate systems, redistribution of the bending moments must be assumed with plastic rotations. Thus, by using a barrier's resistance to both longitudinal bending and overturning, the ultimate strength, or impact load that the barrier can withstand, can be calculated (Figure 3.6).

In the case of GFRP reinforced traffic barriers, moment redistribution cannot be accounted in the analysis of indeterminate structures due to the linear elastic behavior of the material until failure. Therefore, yield line analysis cannot be used. A methodology that imposes equilibrium and compatibility conditions must be adopted in lieu of traditional yield line analysis. In 2009, Matta and Nanni presented the results of full-scale static tests on post-deck connections reinforced with GFRP bars, to assess compliance with strength criteria at the deck to barrier connection, as mandated by the AASHTO Standard Specifications, which were used to design the bridge. Strength and stiffness until failure are shown to be accurately predictable, using the strength-convergence method <sup>50</sup>.



Fig.CA13.3.1-2 AASHTO LRFD 2012

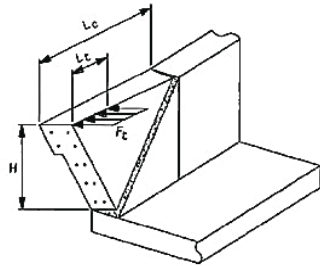

$L_c$  = Critical length of yield line failure pattern

$L_t$  = Longitudinal length of distribution of impact force

$F_t$  = Transverse impact force

Fig.CA13.3.1-1 AASHTO LRFD 2012

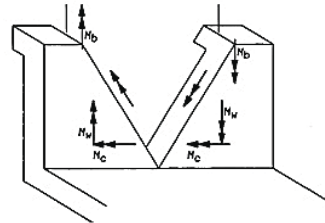

$M_c$  = Flexural resistance of the traffic barrier about its vertical axis.  
RESISTANCE PROVIDED BY TRANSVERSE REINFORCEMENT

$M_b, M_w$  = Flexural resistance of the traffic barrier about an axis parallel to the longitudinal axis of the bridge  
RESISTANCE PROVIDED BY LONGITUDINAL REINFORCEMENT

Figure 3.6 - Yield line analysis of concrete parapet walls for impact within wall segment.

Convergence is achieved for tensile load capacity using an iterative procedure. The methodology to assess the strength level of a GFRP RC railing is proved to be consistent with the bases of the AASHTO LRFD approach. Large deformations are not observed in successful crash tests and are incompatible with optimal functionality characteristics. Hence, torsional effects on the beam can be neglected. For this reason, it is legitimate to approximate the behavior of traffic barrier into a bi-dimensional system. AASHTO provisions<sup>29</sup> are followed for the flexural and shear design and analysis of the GFRP reinforced members.

It must be considered that more accurate analyses can be performed using numerical methods. The connection response under static loading can be modeled with finite elements method (FEM) softwares, running nonlinear analysis of the railing to verify the strength, stiffness and deformations of the connection. The nonlinear material properties

of concrete can be accounted. Thus, the loss in strength and rigidity caused by crack propagation and crack opening can be reproduced in the model. Moreover, tridimensional behavior can be captured and more precise results can be obtained. However, the equilibrium-convergence method provides a simple and effective method for the design of traffic barrier reinforcement. This procedure can be used as a preliminary design when more sophisticated analysis is performed.

When dealing with GFRP RC railings, the following different failure modes may occur:

- Concrete crushing
- GFRP reinforcement rupture in flexure at the weakest connected section
- Insufficient anchorage of the post or development length of the deck reinforcement
- Diagonal tension cracking at the corner.

In the last three cases, the design fails to fully utilize the reinforcement, but may be preferred due to constructability considerations, provided that the strength requirements are met. In the case of diagonal tension cracking of the corner, the design does not allow fully utilizing the reinforcement and must be avoided to prevent permanent damage in the bridge deck. It is important that after failure, the connection does not separate. The ultimate transverse load is attained when the barrier/deck connection reaches its strength, or when the beam moment reaches its nominal value, assumed equal for both positive and negative bending (symmetric reinforcement).

Failure patterns may develop within the bridge deck at load levels considerably smaller than that otherwise expected. Typical factors that affect the behavior of

connection details (not necessarily concurrently) are as follows and must be avoided by the designer by means of accurate detailing and inspection:

- Effectiveness of the barrier/deck construction joint;
- Effectiveness of the anchorage of the bent bars within the deck;
- Developable tensile stress in straight or bent bars in the deck top mat

Manufacturers typically provide material properties that exceed AC454 minimum requirements; thus, guaranteed values provided by a manufacturer are used for the ultimate tensile strength of the reinforcement.

This study provides guidance for the design of a cast-in-place, GFRP RC type parapet<sup>28</sup>. A design example of a TL-4 parapet compliant with FDOT and AASHTO requirements is presented in appendix A. Since the design is performed in MathCad language, a user can alter assumptions, constants, or equations to create a customized application.

A seven steps procedure were implemented for the design of the traffic barrier:

1. Definition of type and geometry
2. Development Length and Reinforcement Splices
3. Design Loads
4. Corner Joint Verification
5. Flexural Verification: Limits for Reinforcement and Flexural Strength
6. Shear Verification: Concrete Shear Strength and Shear Reinforcement Strength
7. Summary of Provided Reinforcement and Detailing

The following assumptions have been incorporated in the design:

- Continuous barriers (no construction joints). Hybrid fixed-pinned end connection to account for the flexural resistance of the barrier about its vertical axis.
- Uniformly distributed impact load <sup>30</sup>
- Phased construction between deck and traffic barriers
- Approximation of the parapet behavior to one way cantilever slab. Therefore AASHTO equation 2.10.2.2-1 <sup>29</sup> does not apply. It is legitimate to consider a fixed restraint between the deck and the traffic barrier, being the corner region very stiff. Tests show that the relative rotation between post and deck section is negligible, and it is mostly developed after cracking.
- An equivalent continuous rectangular beam shape is adopted to simplify flexural and shear verifications.

### 3.7 CORNER JOINT VERIFICATION

The design requires a check against diagonal tension failure at the corner. The transverse load  $F_p$  applied to the barrier produces a compression force  $C_p$  in the barrier, which is transferred to the deck via formation of a diagonal compression strut of length  $l_{dc}$ . The shear force  $F_p$  is transferred to the deck as an axial force  $-F_p$  and a bending moment  $0.5F_p t_d$ , which adds to  $F_p H_e$  to produce the resultant moment in the deck  $M_d$ , that generates the force couple  $C_d$  and  $F_{f,d}$ , as detailed in Figure 3.7. Diagonal cracking may occur prior to flexural failure in the deck as the concrete modulus of rupture  $f_r$  is reached along the diagonal strut. The accuracy of analytical results based on the theory of elasticity has been demonstrated with respect to experimental results (Nilsson and

Losberg ,1976)<sup>51</sup> , where is assumed a parabolic distribution of the tensile stress along  $l_d$ . The tensile force  $T$  acting perpendicular to the diagonal strut is computed neglecting the strength contribution of the slab portions adjacent to the connection. Figure 3.7 shows the free-body diagram of the corner with the resultant internal forces. Figure 3.8 shows the iterative procedure implemented in MathCad to account for an automated strength-convergence computation<sup>50</sup>. In this case study, convergence was achieved for a  $F_{np}$  value of 35.5 kips/ft (518 kN/m). No 6 bars (19 mm mm diameter) spaced 6 in (152 mm) center-to-center were adopted to resist the impact force. The equivalent area produced a factored strength at convergence of 60.3 kips/ft (880 kN/m) exceeding the 54 kips/ft (788 kN/m) of the impact force  $F_p$ .

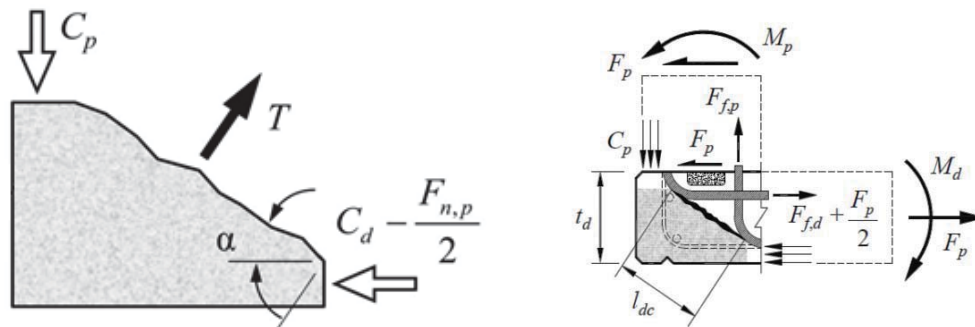

Figure 3.7 - Failure of corner joint: (a) Free body diagram, (b) Internal forces

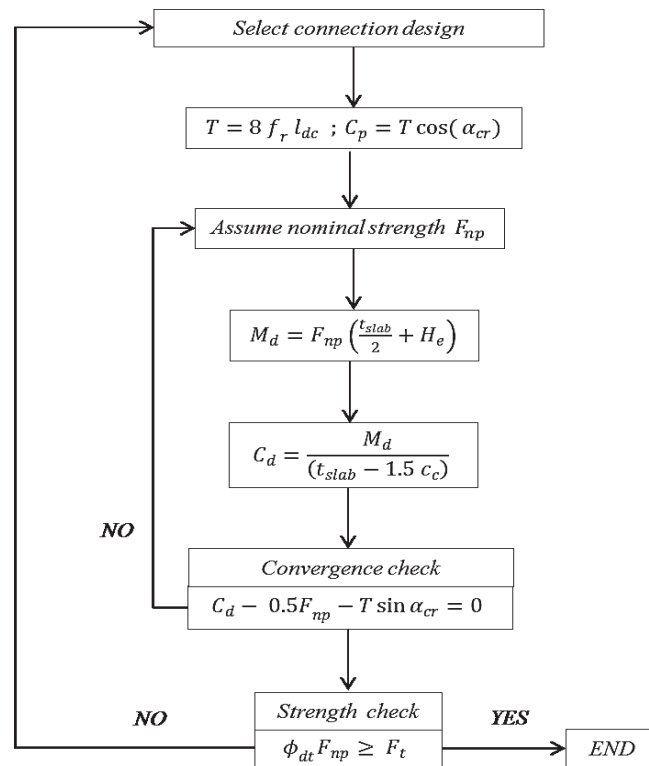

Figure 3.8 - Flowchart for barrier-deck connection design controlled by failure at corner.

### 3.8 FLEXURAL AND SHEAR VERIFICATION

AASHTO<sup>29</sup> requires railings and barriers to be designed for bending moment and shear forces acting about the longitudinal axis of the parapet. The maximum bending moment occurs at the midsection of the length of distribution of the impact force ( $L$ ). The length of distribution varies with test level and ranges from 3.5 ft to 8ft (1.07 to 2.44 m). For TL-4,  $L$  is 3.5 ft (1.07 m). The ultimate bending moment on longitudinal direction acting on the length of distribution of the impact force is assumed to be a load distributed along

*L.* An hybrid fixed-pinned end connection has been selected to account for the flexural resistance of the barrier about its vertical axis <sup>50</sup>.

For TL-4 the ultimate unitary moment  $M_u$  is 19 kips-ft (25.8 kN-m), which corresponds to the maximum applicable for the studied barrier type. The longitudinal reinforcement, accounting for bending resistance, is symmetric and consists of 2 layers of 4 straight bars. The bars range from No.4 to No.8 (from 13 to 25 mm diameter). The factored moment resistance is 50 kips-ft (67.8 kN-m). Reinforcement splices with a minimum length of 42 in (1.07 m) must be provided when necessary.

The shear verification for TL-1, TL-2 and TL-3 is satisfied without need for reinforcement. The factored shear strength provided by the concrete  $\phi_{sh}V_c$  is 26,1 kips (116.1 kN) using a concrete compressive strength  $f'_c$  4,500 psi (31 MPa). The ultimate shear force for TL-4 is 27 kips (120.1 kN). When shear reinforcement is not required, U bent bars should be used for constructability and tied to the vertical reinforcement. The verification for TL-4 is not satisfied without shear reinforcement. The reinforcement provided consists of a set of 3 No. 4 U bent bars, with spacing 33 in (0.84 m). The U-bent bars have different dimensions, since the parapet cross section varies along its vertical axis.

### 3.9 CONCLUSIONS

The validity of GFRP reinforcement for bridge railings and traffic barriers has been demonstrated by a number of studies and field implementations in North America. In the United States, the current design provisions (i.e., ACI and AASHTO) do not include detailed procedures for the design and verification of bridge parapets. In light of the

increased use of GFRP reinforcement in a number of structural applications where connections may be present, design criteria for common GFRP reinforcement layouts and load conditions should be addressed.

Approaches that combine basic structural analysis principles with GFRP RC theory should be selected on a case-by-case basis, depending on the type of corner connection. The study presented in this paper demonstrates the effectiveness of a simple method to determine the nominal and design strength of a GFRP-RC corner joint subjected to combined shear force and opening bending moment. The internal forces were computed by imposing equilibrium and compatibility conditions at the corner, and the associated resistance was back-calculated iteratively until convergence was achieved. Flexural and shear strength along the longitudinal axis were evaluated with well-established procedures. However, more sophisticated numerical analyses may be necessary to ensure strength and to evaluate deflection and other functionality parameters.



## WORK CITED

1. Gerhardus H. Koch, Ph.D., Michiel P.H. Brongers, Neil G. Thompson, Ph.D., Y. Paul Virmani, Ph.D., Joe H. Payer, Ph.D. , Corrosion Cost and Preventive Strategies in the United States , Report No. FHWA-RD-01-156, September 30, 2001.
2. U.S. Department of transportation, National Bridge Inventory Database, 2012, <http://www.fhwa.dot.gov/bridge/nbi.cfm>.
3. American Society of Civil Engineers, 2013 Report Card for America's Infrastructure, [www.infrastructurereportcard.org](http://www.infrastructurereportcard.org).
4. Antonio Nanni, Antonio De Luca, Jawahe, Reinforced Concrete with FRP Bars: Mechanics and Design, CRC Press, ISBN 10: 0415778824, 2014.
5. A.H. Miller, N. Dodds, J.M. Hale and A.G. Gibson, High speed pultrusion of thermoplastic matrix composites, Composites Part A 29A (1998) 773–782 1359-835X/98/\$- 1998 Elsevier Science Ltd.
6. ACI, Guide For The Design And Construction Of Structural Concrete Reinforced With Fiber-Reinforced Polymer (FRP) Bars, ACI 440.1R-15, First Edition, American Concrete Institute Committee 440, Farmington Hills, MI, March 2015.
7. S. Kocaoza , V.A. Samaranayakeb , A. Nanni, Tensile Characterization Of Glass FRP Bars, 2004 Elsevier Ltd.
8. James W. Dally, William Franklin Riley, Experimental Stress Analysis, 1991, , College House Enterprises, 1991.
9. Iman Chitsazan, Mohsen Kobraei, Mohd Zamin Jumaat and Payam Shafigh, An Experimental Study On The Flexural Behavior Of FRP RC Beams And A Comparison Of The Ultimate Moment Capacity With ACI, Journal of Civil Engineering and Construction Technology, Vol. 1(2), pp. 27-42, December 2010.
10. Antonio Nanni, Flexural Behavior And Design Of RC Members Using FRP Reinforcement, J. Struct. Eng. 1993.119:3344-3359.
11. AASHTO, Standard Specifications for Highway Bridges, 17th edition, American Association of State Highway and Transportation Officials, Washington, DC, 2002.
12. P. Jackson Giord and Partners, Design Of Reinforced Concrete Bridges, ICE Manual Of Bridge Engineering # 2008 Institution of Civil Engineers, doi: 10.1680/mobe.34525.0185.

13. Sandy Shuk-Yan Poon, Optimization Of Span-To-Depth Ratios In High-Strength Concrete Girder Bridges, Graduate Department of Civil Engineering University of Toronto, 2009.
14. U.S. Department of Transportation Federal Highway Administration, Steel Bridge Design Handbook, Publication No. FHWA-IF-12-052 - Vol. 5, November 2012.
15. Fu, Gongkang. Bridge Design and Evaluation: LRFD and LRFR. Somerset, NJ, USA: John Wiley & Sons, 2013.
16. Ye, L. P.; Feng, P.; Zhang, K.; Lin, L.; Hong, W. H.; Yue, Q. R.; Zhang, N.; and Yang, T., 2003, FRP in Civil Engineering in China: Research and Applications, Proceedings of the Sixth International Symposium on FRP Reinforcement for Concrete Structures (FRPRCS-6), K. H. Tan, ed., Singapore, p. 1401.
17. Meier, U., 1992, Carbon Fiber Reinforced Polymers: Modern Materials in Bridge Engineering, Structural Engineering International, Journal of the International Association for Bridge and Structural Engineering, V. 2, No. 1, pp. 7-12.
18. Taerwe, L., 1997, FRP Activities in Europe: Survey of Research and Applications, Proceedings of the Third International Symposium on Non-Metallic (FRP) Reinforcement for Concrete Structures (FRPRCS-3), V. 1, Japan Concrete Institute, Tokyo, Japan, pp. 59-74.
19. Canadian Standards Association, CSA S-807: Specification for Fibre-Reinforced Polymers, 2010.
20. Rizkalla, S. H., 1997, A New Generation of Civil Engineering Structures and Bridges, Proceedings of the Third International Symposium on Non-Metallic (FRP) Reinforcement for Concrete Structures (FRPRCS-3), V. 1, Japan Concrete Institute, Tokyo, Japan, pp. 113-128.
21. Benmokrane, B.; El-Salakawy, E.; El-Ragaby, A.; Desgagne, G.; and Lackey, T., 2004, Design, Construction and Monitoring of Four Innovative Concrete Bridge Decks Using Non-Corrosive FRP Composite Bars, 2004 Annual Conference of the Transportation Association of Canada, Québec City, Québec, Canada.
22. ICC, 2015 International building code (IBC), International code council, Country Club Hills, IL, 2014.
23. ICC, 2015 International existing building code (IEBC), International code council, Country Club Hills, IL, 2014.

24. ISO/IEC 17065:2012, Conformity Assessment – Requirements For Bodies Certifying Product, Processes And Services, International organization for standardization, Geneva, Switzerland, 27 pp.
25. AC454, Acceptance Criteria For Glass-Fiber Reinforced Polymer (GFRP) Bars For Internal Reinforcement Of Concrete Members, ICC evaluation service, Brea, CA, 2014.
26. FDOT, Standard Specifications For Road And Bridge Construction, Florida Department of Transportation, Tallahassee, FL, 2013.
27. FDOT, Structures Design Guidelines, Florida Department of Transportation, Tallahassee, FL, 2015.
28. AASHTO, AASHTO LRFD Bridge Design Specifications, Seventh edition, American Association of State Highway and Transportation Officials, Washington, DC, 2014.
29. AASHTO, AASHTO LRFD Bridge Guide Specifications For GFRP-Reinforced Concrete Bridge Decks And Traffic Railings, First edition, American Association of State Highway and Transportation Officials, Washington, DC, 2009.
30. ACI 318-14, ACI, Building Code Requirements For Structural Concrete And Commentary, 2014 Edition, American Concrete Institute Committee 440, Farmington Hills, MI, March 2015.
31. Hellriegel, E.J., Development of The Narrow Median Concrete Barrier In New Jersey, Presented at the 38th Annual Meeting of Institute of Traffic Engineers, August, 1968, Nordlin, E.F., Field, R.N., Stoker, J.R., Pelkey, R.A., and Halterman, J.A., Dynamic Tests of Concrete Median Barrier Series XVI, State of California Transportation Agency, Division of Highways, August 1967.
32. Rosenbaugh, S. K., Development Of A TL-5 Vertical Faced Concrete Median Barrier Incorporating Head Ejection Criteria, University of Nebraska-Lincoln 527 Nebraska Hall, December 10, 2007.
33. National Cooperative Highway Research Program (NCHRP). (1993). Recommended Procedures For The Safety Performance Evaluation, Of Highway Features, Rep. No. 350, Transportation Research Board, Washington, DC.
34. Ross, H.E., Sicking, D.L., Zimmer, R.A., and Michie, J.D., Recommended Procedures for the Safety Performance Evaluation of Highway Features, NCHRP Report 350, 1993.

35. El-Salakawy, E., Benmokrane, B., Masmoudi, R., Brière, F., and Breaumier, E., (2003), Concrete Bridge Barriers Reinforced With Glass Fiber-Reinforced Polymer Composite Bars. *ACI Struct. J.*, 100(6) 815–82.
36. CAN/CSA-S6-06, Canadian Highway Bridge Design Code.
37. Benmokrane, B., El-Salakawy, E., El-Gamal, S., and Goulet, S., Construction and Testing of Canada's First Concrete Bridge Deck Totally Reinforced With Glass FRP Bars: Val-Alain Bridge on Highway 20 East." *J. Bridge Eng.*, 12(5), 632–64.
38. Buth, C. E., Williams, W. F., Bligh, R. P., Menges, W. L., and Haug, R. R., Performance of The Txdot T202 (MOD) Bridge Rail Reinforced With Fiber Reinforced Polymer Bars, TTI Research Report 0- 4138-3, Texas Transportation Institute, 2003.
39. Matta, F., Nanni, A., and Bank, L. C., Prefabricated FRP Reinforcement for Concrete Bridge Deck and Railing: Design, Laboratory Validation, and Field Implementation, Asia-Pacific Conference on FRP in Structures (APFIS 2007), S.T. Smith, 2007 International Institute for FRP in Construction.
40. Ehab A. Ahmed; Fabio Matta; Brahim Benmokrane, Steel Post-and-Beam Barrier with GFRP-Reinforced Concrete Curb and Bridge Deck Connection, *Journal of Bridge Engineering ASCE / November 2013*, *J. Bridge Eng.* 2013.18:1189-1197.
41. John Street CNR Overhead Bridge, Ontario, Canada, Aslan FRP, Hughes Brothers, Inc., personal communication.
42. R.J. Burnside & Associates, Adjala-Tosorontio Bridge No.9 Replacement, 2012.
43. Lakeshore Shop Drawings Sheet 3 Revised 2013-04-10, personal communication.
44. Eglinton Avenue Bridge, Toronto, Canada, 2009, Aslan FRP, Hughes Brothers, Inc., personal communication.
45. CBCL Consulting Engineers, Clark's Mill Bridge, Prince County, Canada, 2007, Clarks Mill Bridge 3 of 3 Revised.
46. Ross Corner Bridge Canada, 2011, Aslan FRP, Hughes Brothers, Inc., personal communication.
47. Liao, H., Rehabilitation of the Baden Creek Bridge, Vector Corrosion Technologies, personal communication.
48. Planmac Inc., Tenth Line Bridge Rehabilitation, 2012, personal communication.

49. Hirsch, T. J., Analytical Evaluation Of Texas Bridge Rails To Contain Buses And Trucks, Rep. No. FHWATX-78-230-2, Texas Transportation Institute, College Station, TX.
50. Matta, F., and Nanni, A., "Connection of Concrete Railing Post and Bridge Deck with Internal FRP Reinforcement", *Journal Of Bridge Engineering*, ASCE, January/February, 2009, Vol.14, 66-76.
51. Nilsson, I. H. E., and Losberg, Reinforced Concrete Corners and Joints Subjected to Bending Moment, *J. Struct. Div.*, 102, 6, 1229–1254, 1976.
52. McGraw Hill Construction, 2009 Green Outlook: Trends Driving Change, McGraw Hill Construction 2009, Washington, DC.
53. Green building facts, United States Green Building Council 2009. Washington, DC.
54. De Caso y Basalo, Francisco Jose, Sustainable Composite Systems for Infrastructure Rehabilitation, University of Miami, Open Access Dissertations, Paper 495, 2010.
55. Civil Engineering Research Foundation (CERF). Gap Analysis for Durability of Fiber Reinforced Polymer Composites in Civil Infrastructure." American Society of Civil Engineers 2001. New York, NY.
56. Bakis, C. Life Cycle Analysis Issues in the Use of FRP Composites in Civil Infrastructure." *Proceedings US-Japan Workshop on Life Cycle Assessment of Sustainable Infrastructure Materials 2009*. Sapporo, Japan.
57. Chao, Z., Wenxiu, L., Muhammad, A. & Lee, C. (2012) Environmental Evaluation of FRP in UK Highway Bridge Deck Replacement Applications based on a Comparative LCA Study.
58. Xi'an. Nishizaki, I., Takeda, N., Ishizuka, Y. & Shimomura, T. A Case Study of Life Cycle Cost based on a Real FRP Bridge. *Third International Conference on FRP Composites in Civil Engineering*, CICE 2006.
59. Zhang, C., Amaduddin, M. & Canning, L., Carbon Dioxide Evaluation in a Typical Bridge Deck Replacement Project. *Proceedings of Institution of Civil Engineers: Energy*, 164(4), 183-194, 2011.

**APPENDIX A:**  
**FDOT LRFD #2A DESIGN EXAMPLE**



---

## LRFD Design Example #2A:

### Cast-in-Place Flat Slab Bridge Design with GFRP Bar Reinforcement

---

Click [here](#) for Table of Contents

**HDR** | ONE COMPANY  
*Many Solutions<sup>SM</sup>*  
2202 N. West Shore Blvd., Suite 250  
Tampa, FL 33607  
(813) 282-2300

 COLLEGE of  
ENGINEERING



## LRFD DESIGN EXAMPLE: CAST-IN-PLACE FLAT SLAB BRIDGE DESIGN WITH GFRP REINFORCEMENT

### Preface

---

Given the document "LRFD Design Example #2", generated by HDR Engineering, Inc. for the Florida Department of Transportation (FDOT), the work of University of Miami, Department of Civil, Architectural and Environmental Engineering (CAE), is to:

- Edit the given example to account for properties of Glass Fiber Reinforced Polymer (GFRP) bars.
- Implement new algorithms to allow for the design of the GFRP-reinforced bridge superstructure (deck and traffic barrier) and substructure (pile cap).
- Update standards and references.
- Enrich the given example with notes, comments and drawings.

*Coral Gables, FL  
Januray 10, 2015*

*Antonio Nanni, Professor & Chair  
Valentino Rinaldi, MS  
Yading Dai, MS  
Guillermo Claure, PhD candidate*





**LRFD DESIGN EXAMPLE:  
CAST-IN-PLACE FLAT SLAB BRIDGE DESIGN WITH GFRP REINFORCEMENT**  
**Table of Contents**

Cover

---

**Section 1: PROJECT INFORMATION**

- 1.01 [About this LRFD Flat Slab Bridge Design Example](#)
- 1.02 [General Notes](#)
- 1.03 [Design Parameters](#)
- 1.04 [Material Properties](#)

**Section 2: SUPERSTRUCTURE DESIGN**

- 2.01 [Flat Slab Design Loads](#)
- 2.02 [GFRP-reinforced Flat Slab Design](#)
- 2.03 [Edge Beam Design Loads](#)
- 2.04 [GFRP-reinforced Edge Beam Design](#)
- 2.05 [GFRP-reinforced Traffic Barrier Design](#)
- 2.06 [Expansion Joint Design](#)

**Section 3: SUBSTRUCTURE DESIGN**

- 3.01 [Bent 2 Cap Design Loads](#)
- 3.02 [GFRP-reinforced Bent 2 Cap Design](#)
- 3.03 [Bent 2 Piles Vertical Load Design](#)



## SUPERSTRUCTURE DESIGN

### About this Design Example

---

#### Description

This document provides guidance for the design of a cast-in-place flat slab bridge with GFRP-reinforcement.

The example includes the following component designs:

- GFRP-reinforced solid CIP slab design
- GFRP-reinforced edge beam design
- TL-4 GFRP-reinforced traffic barrier
- Expansion joint design
- GFRP-reinforced intermediate bent cap design

The following assumptions have been incorporated in the example:

- Three span continuous @ 35'-0" each for a total of 105'-0" bridge length
- 30 degree skew
- No phased construction
- Two traffic railing barriers and one median barrier
- No sidewalks
- Permit vehicles are not considered
- Load rating is not addressed

Since this example is presented in a **Mathcad** document, a user can alter assumptions, constants, or equations to create a customized application.

### Standards

The example utilizes the following design standards:

- [AASHTO LRFD 2014] - AASHTO LRFD Bridge Design Specifications, 2014
- [AASHTO GFRP 2009] - AASHTO LRFD Bridge Guide Specifications for GFRP-Reinforced Concrete Bridge Decks and Traffic Railings, 2009
- [FDOT 2013] - Florida Department of Transportation Standard Specifications for Road and Bridge Constructions, 2013
- [FDOT 2003] - Florida Department of Transportation Structures LRFD Design Guidelines, 2003
- [SDG 2015] - Structural Design Guide, Florida Department of Transportation, January 2015

### References

- [ACI 440.1R-14] - Guide for the Design and Construction of Structural Concrete Reinforced with FRP Bars, 2014
- [AC454 2014]-Acceptance Criteria for Glass Fiber-Reinforced Polymer (GFRP) Bars for Internal Reinforcement of Concrete and Masonry Members
- AISC Moment, Shears and Reactions for Continuous Highway Bridges, 1987
- F. Matta and A. Nanni, "Connection of Concrete Railing Post and Bridge Deck with Internal FRP Reinforcements" Journal of Bridge Engineering, ASCE, Vol.14, No.1, January/February 2009

### Defined Units

All calculations in this electronic book use U.S. customary units. The user can take advantage of Mathcad's unit conversion capabilities to solve problems in MKS or CGS units. Although Mathcad has several built-in units, some common structural engineering units must be defined. For example, a lbf is a built-in Mathcad unit, but a kip or ton is not. Therefore, a kip and ton are globally defined as:

$$\text{kip} \equiv 1000 \cdot \text{lbf}$$

$$\text{ton} \equiv 2000 \cdot \text{lbf}$$

Definitions for some common structural engineering units:

$$\text{N} \equiv \text{newton}$$

$$\text{kN} \equiv 1000 \cdot \text{newton}$$

$$\text{plf} \equiv \frac{\text{lbf}}{\text{ft}}$$

$$\text{psf} \equiv \frac{\text{lbf}}{\text{ft}^2}$$

$$\text{pcf} \equiv \frac{\text{lbf}}{\text{ft}^3}$$

$$\text{psi} \equiv \frac{\text{lbf}}{\text{in}^2}$$

$$\text{klf} \equiv \frac{\text{kip}}{\text{ft}}$$

$$\text{ksf} \equiv \frac{\text{kip}}{\text{ft}^2}$$

$$\text{ksi} \equiv \frac{\text{kip}}{\text{in}^2}$$

$$^{\circ}\text{F} \equiv 1 \text{ deg}$$

$$\text{MPa} \equiv 1 \cdot 10^6 \cdot \text{Pa}$$

$$\text{GPa} \equiv 1 \cdot 10^9 \cdot \text{Pa}$$

Note: Anytime that a symbol is shown as  $\text{xxx} := 1 \text{ xxx} := 1$  it is not an error, but it indicates a repetition of variable symbol.

A variable with yellow highlight represents an input from engineer.

### Notice

The materials in this document are only for general information purposes. This document is not a substitute for competent professional assistance. Anyone using this material does so at his or her own risk and assumes any resulting liability.



**PROJECT INFORMATION**

**General Notes**

**Design Method.....** Load and Resistance Factor Design (LRFD) except that Prestressed Piles have been designed for Service Load.

**Design Loading.....** HL-93 Truck

**Future Wearing Surface...** Design provides allowance for 15 psf

**Earthquake.....** Seismic provisions for minimum bridge support length only [SDG 2.3.1].

<b>Concrete.....</b>	<b>Class</b>	<u>Minimum 28-day Compressive</u>	<u>Location</u>
		<u>Strength (psi)</u>	
	II	f' c = 3400	Traffic Barriers
	II (Bridge Deck)	f' c = 4500	CIP Flat Slab
	IV	f' c = 5500	CIP Substructure
	V (Special)	f' c = 6000	Concrete Piling

**Environment.....** The superstructure is classified as slightly aggressive.  
The substructure is classified as moderately aggressive.

**GFRP reinforcement.....** The reinforcing bars meet the requirements of AC454 by ICC-ES.

<b>Concrete Cover.....</b>	<b>Superstructure</b>	
	Top deck surfaces	1.5" (Short bridge)
	Traffic barrier	1.5"
	All other surfaces	1.5"
	<b>Substructure</b>	
	External surfaces exposed	1.5"
	External surfaces cast against earth	4"
	Prestressed piling	3"

Note: The cover can be set to 1.5 in being corrosion not an issue for GFRP.

Concrete cover does not include reinforcement placement or fabrication tolerances, unless shown as "minimum cover". See FDOT Standard Specifications for allowable reinforcement placement tolerances.

**Dimensions.....** All dimensions are in feet or inches, except as noted.



## PROJECT INFORMATION

### Design Parameters

---

#### Description

This section provides the design input parameters necessary for the superstructure and substructure design.

<b>Page</b>	<b>Contents</b>
5	A. General Criteria <ul style="list-style-type: none"> <li>A1. Bridge Geometry</li> <li>A2. Number of Lanes</li> <li>A3. Concrete, Reinforcing and Reinforcement Properties</li> </ul>
8	B. LRFD Criteria <ul style="list-style-type: none"> <li>B1. Dynamic Load Allowance [AASHTO LRFD 2014, 3.6.2]</li> <li>B2. Resistance Factors [AASHTO LRFD 2014, 5.5.4.2]</li> <li>B3. Limit States [AASHTO LRFD 2014, 1.3.2]</li> </ul>
10	C. Florida Criteria <ul style="list-style-type: none"> <li>C1. Chapter 1 - General Requirements</li> <li>C2. Chapter 2 - Loads and Load Factors</li> <li>C3. Chapter 4 - Superstructure Concrete</li> <li>C4. Chapter 6 - Superstructure Components</li> <li>C5. Miscellaneous</li> </ul>
13	D. Substructure <ul style="list-style-type: none"> <li>D1. Intermediate Bent Geometry</li> </ul>

### A. General Criteria

This section provides the general layout and input parameters for the bridge example.

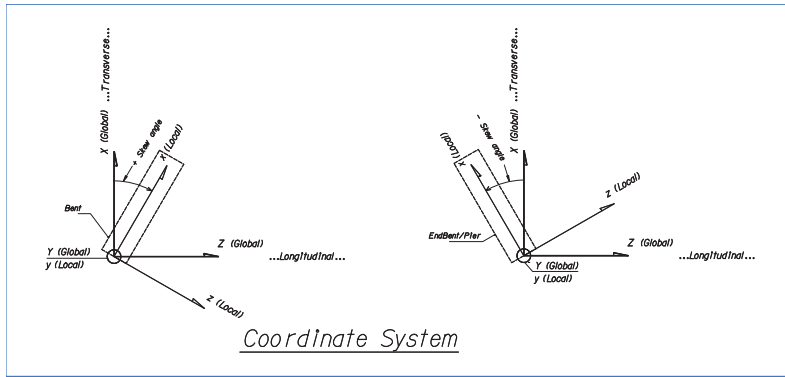

In addition, the bridge is also on a skew which is defined as:

Skew Angle..... **Skew := -30deg**

### A1. Bridge Geometry

#### Horizontal Profile

A slight horizontal curvature is shown in the plan view. For all component designs, the horizontal curvature will be taken as zero.

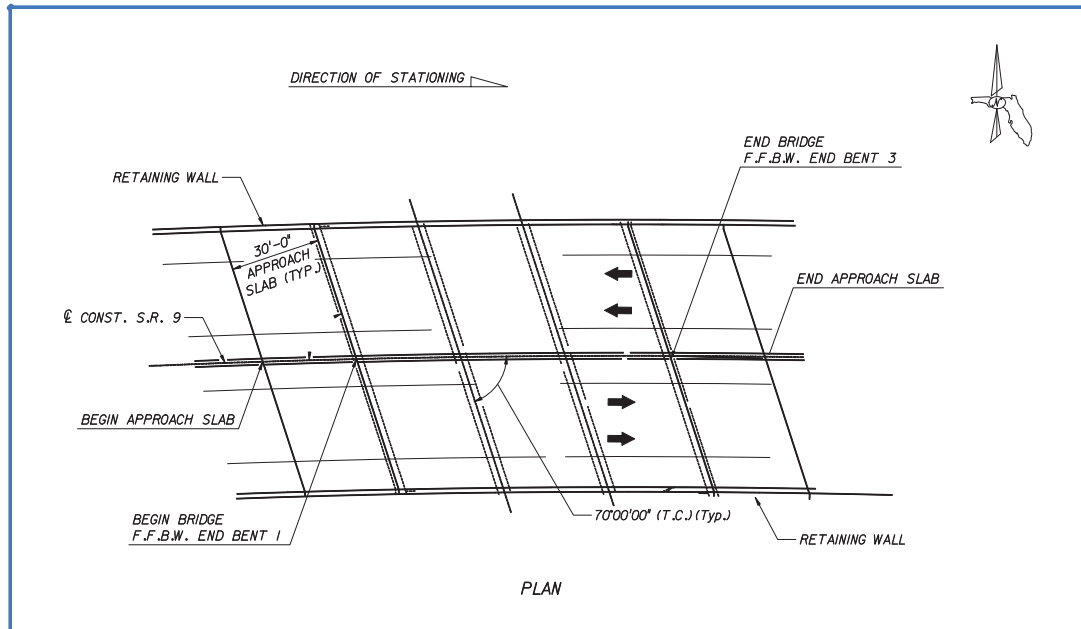

**HORIZONTAL CURVE DATA**  
 $R = 3,800'$

**Vertical Profile**

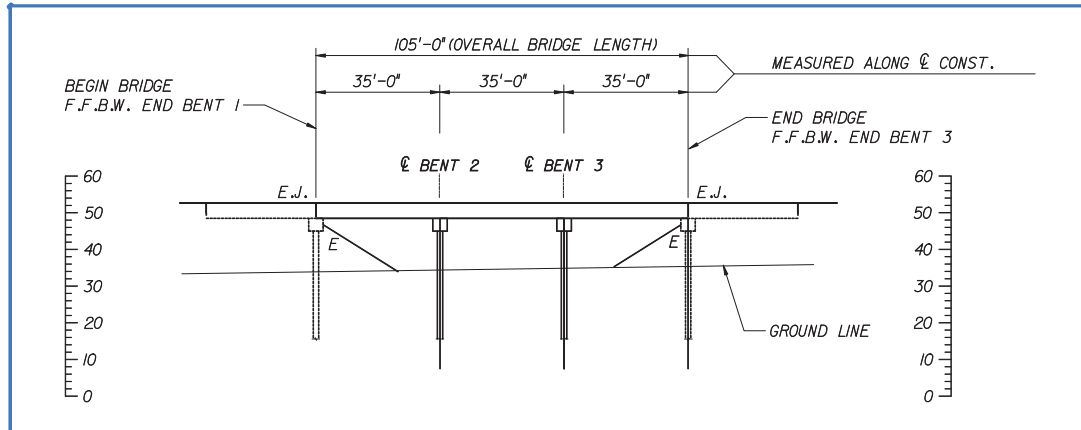

Overall bridge length.....  $L_{\text{bridge}} \equiv 105 \cdot \text{ft}$

Bridge design span length.....  $L_{\text{span}} := 35 \cdot \text{ft}$

(Note: For unsymmetric spans, use average span length)

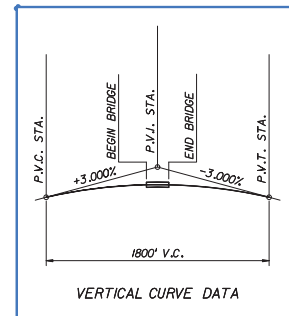

Dimension of Bridge in Front View

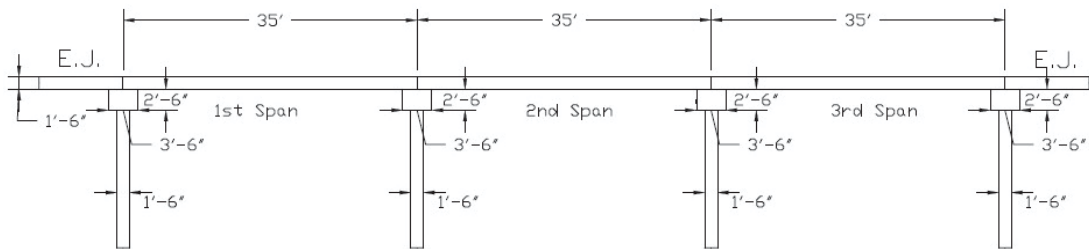

**Typical Cross-section**

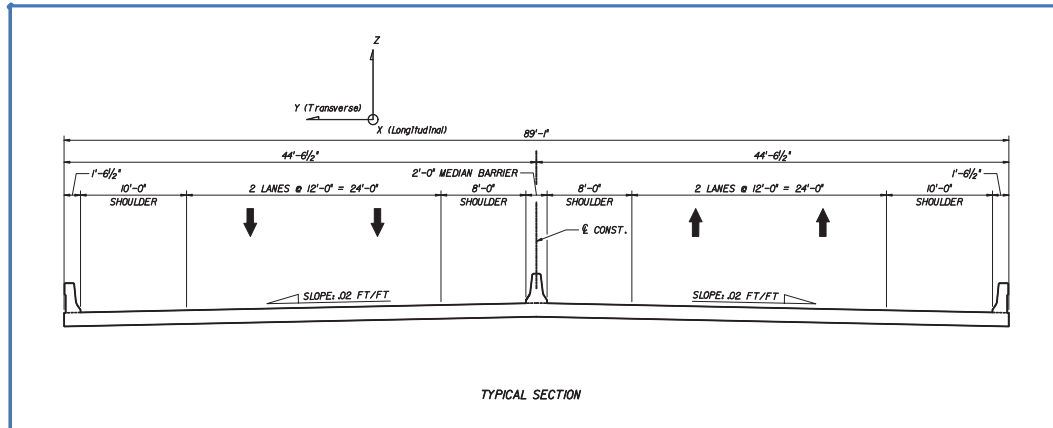

Overall bridge width.....  $W_{bridge} := 89.1 \cdot ft$

**A2. Number of Lanes**

**Design Lanes**

Current lane configurations show two striped lanes per roadway with a traffic median barrier separating the roadways. Using the roadway clear width between barriers,  $Rdwy_{width}$ , the number of design traffic lanes per roadway,  $N_{lanes}$ , can be calculated as:

Roadway clear width.....  $Rdwy_{width} := 42 \cdot ft$

Number of design traffic lanes per roadway.....  $N_{lanes} := floor\left(\frac{Rdwy_{width}}{12 \cdot ft}\right)$   
 $N_{lanes} = 3$

**A3. Concrete, Reinforcing and Prestressing Steel Properties**

Unit weight of concrete.....  $\gamma_{conc} := 150 \cdot pcf$

Modulus of elasticity for reinforcing steel.....  $E_s := 29000 \cdot ksi$



## B. LRFD Criteria

The bridge components are designed in accordance with the following LRFD design criteria:

### B1. Dynamic Load Allowance [AASHTO LRFD 2014, 3.6.2]

An impact factor will be applied to the static load of the design truck or tandem, except for centrifugal and braking forces.

Impact factor for fatigue and fracture limit states.....  $IM_{\text{fatigue}} := 1 + \frac{15}{100}$

Impact factor for all other limit states.....  $IM := 1 + \frac{33}{100}$

### B2. Resistance Factors [AASHTO GFRP 2009 ]

Flexure and tension of reinforced concrete.....  $\phi_f =$  from 0.55 to 0.65 depending on the reinforcement ratio

[AASHTO GFRP 2009, 2.9.2.1]

Shear and torsion of normal weight concrete.....  $\phi_v = 0.75$  [AASHTO GFRP 2009, 2.7.4.2]

### B3. Limit States [AASHTO LRFD 2014, 1.3.2]

The LRFD defines a limit state as a condition beyond which the bridge or component ceases to satisfy the provisions for which it was designed. There are four limit states prescribed by LRFD. These are as follows:

#### STRENGTH LIMIT STATE

Load combinations which ensures that strength and stability, both local and global, are provided to resist the specified load combinations that a bridge is expected to experience in its design life. Extensive distress and structural damage may occur under strength limit state, but overall structural integrity is expected to be maintained.

#### EXTREME EVENT LIMIT STATES

Load combinations which ensure the structural survival of a bridge during a major earthquake or flood, or when collided by a vessel, vehicle, or ice flow, possibly under scoured conditions. Extreme event limit states are considered to be unique occurrences whose return period may be significantly greater than the design life of the bridge.

#### SERVICE LIMIT STATE

Load combinations which place restrictions on stress, deformation, and crack width under regular service conditions.

### FATIGUE LIMIT STATE

Load combinations which place restrictions on stress range as a result of a single design truck. It is intended to limit crack growth under repetitive loads during the design life of the bridge.

**Table 3.4.1-1 - Load Combinations and Load Factors**

Load Combination	DC DD DW	LL IM CE	WA	WS	WL	FR	TU CR SH	TG	SE	Use One of These at a Time			
										EQ	IC	CT	CV
Limit State	EH EV ES	BR PL LS											
Strength I	$y_p$	1.75	1.00	-	-	1.00	0.50/1.20	$y_{TG}$	$y_{SE}$	-	-	-	-
Strength II	$y_p$	1.35	1.00	-	-	1.00	0.50/1.20	$y_{TG}$	$y_{SE}$	-	-	-	-
Strength III	$y_p$	-	1.00	1.40	-	1.00	0.50/1.20	$y_{TG}$	$y_{SE}$	-	-	-	-
Strength IV EH, EV, ES, DW, and DC ONLY	$y_p$ 1.5	-	1.00	-	-	1.00	0.50/1.20	-	-	-	-	-	-
Strength V	$y_p$	1.35	1.00	0.40	0.40	1.00	0.50/1.20	$y_{TG}$	$y_{SE}$	-	-	-	-
Extreme Event I	$y_p$	$y_{EQ}$	1.00	-	-	1.00	-	-	-	1.00	-	-	-
Extreme Event II	$y_p$	0.50	1.00	-	-	1.00	-	-	-	-	1.00	1.00	1.00
Service I	1.00	1.00	1.00	0.30	1.00	1.00	1.00/1.20	$y_{TG}$	$y_{SE}$	-	-	-	-
Service II	1.00	1.30	1.00	-	-	1.00	1.00/1.20	-	-	-	-	-	-
Service III	1.00	0.80	1.00	-	-	1.00	1.00/1.20	$y_{TG}$	$y_{SE}$	-	-	-	-
Fatigue	-	0.75	-	-	-	-	-	-	-	-	-	-	-

**Table 3.4.1-2 - Load factors for permanent loads,  $y_p$**

Type of Load	Load Factor	
	Maximum	Minimum
DC: Component and Attachments	1.25	0.90
DD: Downdrag	1.80	0.45
DW: Wearing Surfaces and Utilities	1.50	0.65
EH: Horizontal Earth Pressure		
• Active	1.50	0.90
• At-Rest	1.35	0.90
EL: Locked-in Erection Stresses	1.00	1.00
EV: Vertical Earth Pressure		
• Overall Stability	1.00	N/A
• Retaining Walls and Abutments	1.30	0.90
• Rigid Buried Structure	1.35	0.90
• Rigid Frames	1.95	0.90
• Flexible Buried Structures other than Metal Box Culverts	1.50	0.90
• Flexible Metal Box Culverts		
ES: Earth Surcharge	1.50	0.75

**B4. Span-to-Depth Ratios in LRFD [AASHTO LRFD 2014, 2.5.2.6.3]**

For continuous reinforced slabs with main reinforcement parallel to traffic

$$t_{\min} = \frac{S + 10}{30} \geq 0.54 \cdot \text{ft}$$

Minimum slab thickness

$$t_{\min} := \max\left(\frac{L_{\text{span}} + 10 \cdot \text{ft}}{30}, 0.54 \cdot \text{ft}\right) \quad t_{\min} = 18 \cdot \text{in}$$

Thickness of flat slab chosen.....  $t_{\text{slab}} := 18 \cdot \text{in}$

Slab width used for computation.....  $b_{\text{slab}} := 12 \cdot \text{in}$

**C. FDOT Criteria**

**C1. Chapter 1 - General Requirements**

**General [SDG 2015, 1.1]**

- The design life for bridge structures is 75 years.
- Approach slabs are considered superstructure component.
- Class II Concrete (Bridge Deck) will be used for all environmental classifications.

**Criteria for Deflection only [SDG 2015, 1.2]**

This provision for deflection only is not applicable, since no pedestrian loading is applied in this bridge design example.

**Concrete and Environment [SDG 2015, 1.3]**

The concrete cover for the slab is based on either the environmental classification [SDG 2015, 1.4] or the type of bridge [SDG 2015, 4.2.1].

Concrete clear cover for the slab..  $c_c := 1.5 \cdot \text{in}$

Concrete clear cover for substructure not in contact with water  $c_c = 1.5 \cdot \text{in}$

Minimum 28-day compressive strength of concrete components

<u>Class</u>		<u>Location</u>
II (Bridge Deck)	CIP Bridge Deck	$f_{c,\text{slab}} := 4.5 \cdot \text{ksi}$
IV	CIP Substructure	$f_{c,\text{sub}} := 5.5 \cdot \text{ksi}$
V (Special)	Concrete Piling	$f_{c,\text{pile}} := 6.0 \cdot \text{ksi}$

**Environmental Classifications [SDG 2015, 1.4]**

The environment can be classified as either "Slightly", "Moderately" or "Extremely" aggressive.

Environmental classification for superstructure..... Environment<sub>super</sub> = "Slightly"

Environmental classification for substructure..... Environment<sub>sub</sub> = "Moderately"

**C2. Chapter 2 - Loads and Load Factors**

**Dead loads [SDG 2015, 2.2]**

Weight of future wearing surface

$$\rho_{fws} := \begin{cases} 15 \cdot \text{psf} & \text{if } L_{\text{bridge}} < 300\text{ft} \\ 0 \cdot \text{psf} & \text{otherwise} \end{cases} \quad \rho_{fws} = 15 \cdot \text{psf}$$

Weight of sacrificial milling surface, using  $t_{\text{mill}} = 0 \cdot \text{in}$

$$\rho_{\text{mill}} := t_{\text{mill}} \cdot \gamma_{\text{conc}} \quad \rho_{\text{mill}} = 0 \cdot \text{psf} \quad (\text{Note: See Sect. C3 [SDG 4.2] for calculation of } t_{\text{mill}}).$$

**Seismic Provisions [SDG 2015, 2.3]**

Seismic provisions for minimum bridge support length only.

**Miscellaneous Loads [SDG 2015, 2.5]**

ITEM	UNIT	LOAD
Traffic Railing Barrier (32" F-Shape)	Lb / ft	421
Traffic Railing Median Barrier, (32" F- Shape)	Lb / ft	486
Traffic Railing Barrier (42" Vertical Shape)	Lb / ft	587
Traffic Railing Barrier (32" Vertical Shape)	Lb / ft	385
Traffic Railing Barrier (42" F-Shape)	Lb / ft	624
Traffic Railing Barrier / Soundwall (Bridge)	Lb / ft	1008
Concrete, Structural	Lb / ft <sup>3</sup>	150
Future Wearing Surface	Lb / ft <sup>2</sup>	15 *
Soil, Compacted	Lb / ft <sup>3</sup>	115
Stay-in-Place Metal Forms	Lb / ft <sup>2</sup>	20 **

\* The Future Wearing Surface allowance applies only to minor widenings or short bridges as defined in SDG Chapter 7.

\*\* Unit load of metal forms and concrete required to fill the form flutes to be applied over the projected plan area of the metal forms

Weight of traffic railing barrier..... w<sub>barrier</sub> := 421 · plf

Weight of traffic railing median barrier..... w<sub>median.bar</sub> := 486 · plf

**Barrier / Railing Distribution for Beam-Slab Bridges [SDG 2015, 2.8]**

The traffic railing barriers and median barriers will be distributed equally over the full bridge cross-section.

### C3. Chapter 4 - Superstructure Concrete

#### General [SDG 2015, 4.1]

Correction factor for Florida limerock coarse aggregate

$$\phi_{\text{limerock}} := 0.9$$

Unit Weight of Florida limerock concrete

$$w_{\text{c.limerock}} := 145 \cdot \text{pcf}$$

Yield strength of reinforcing steel

$$f_y := 60 \cdot \text{ksi}$$

*Note: Epoxy coated reinforcing not allowed on FDOT projects.*

Modulus of elasticity for slab

$$E_{\text{c.slub}} := \phi_{\text{limerock}} \cdot (1820 \cdot \sqrt{f_{\text{c.slub}} \cdot \text{ksi}})$$

$$E_{\text{c.slub}} = 3475 \cdot \text{ksi}$$

Modulus of elasticity for substructure

$$E_{\text{c.sub}} := \phi_{\text{limerock}} \cdot (1820 \cdot \sqrt{f_{\text{c.sub}} \cdot \text{ksi}})$$

$$E_{\text{c.sub}} = 3841 \cdot \text{ksi}$$

Modulus of elasticity for piles

$$E_{\text{c.pile}} := \phi_{\text{limerock}} \cdot (1820 \cdot \sqrt{f_{\text{c.pile}} \cdot \text{ksi}})$$

$$E_{\text{c.pile}} = 4012 \cdot \text{ksi}$$

#### Concrete Deck Slabs [SDG 2015, 4.2]

Bridge length definition

$$\text{BridgeType} := \begin{cases} \text{"Short"} & \text{if } L_{\text{bridge}} < 300\text{ft} \\ \text{"Long"} & \text{otherwise} \end{cases}$$

$$\text{BridgeType} = \text{"Short"}$$

Thickness of sacrificial milling surface

$$t_{\text{mill}} \equiv \left( \begin{cases} 0 \cdot \text{in} & \text{if } L_{\text{bridge}} < 300\text{ft} \\ 0.5 \cdot \text{in} & \text{otherwise} \end{cases} \right)$$

$$t_{\text{mill}} = 0 \cdot \text{in}$$

Slab thickness

$$t_{\text{slab}} = 18 \cdot \text{in}$$

### C4. Chapter 6 - Superstructure Components

#### Temperature Movement [SDG 2015, 6.3]

Structural Material of Superstructure	Temperature (Degrees Fahrenheit)			
	Mean	High	Low	Range
Concrete Only	70	95	45	50
Concrete Deck on Steel Girder	70	110	30	80
Steel Only	70	120	30	90

The temperature values for "Concrete Only" in the preceding table apply to this example.

Temperature mean.....	$t_{\text{mean}} := 70 \cdot ^\circ\text{F}$
Temperature high.....	$t_{\text{high}} := 95 \cdot ^\circ\text{F}$
Temperature low.....	$t_{\text{low}} := 45 \cdot ^\circ\text{F}$
Temperature rise	
$\Delta t_{\text{rise}} := t_{\text{high}} - t_{\text{mean}}$	$\Delta t_{\text{rise}} = 25 \cdot ^\circ\text{F}$
Temperature fall	
$\Delta t_{\text{fall}} := t_{\text{mean}} - t_{\text{low}}$	$\Delta t_{\text{fall}} = 25 \cdot ^\circ\text{F}$
Coefficient of thermal expansion [AASHTO LRFD 2014, 5.4.2.2] for normal weight concrete.....	$\alpha_t := \frac{6 \cdot 10^{-6}}{^\circ\text{F}}$

**Expansion Joints [SDG 2015, 6.4]**

Joint Type	Maximum Joint Width *
Poured Rubber	¾"
Silicone Seal	2"
Strip Seal	3"
Modular Joint	Unlimited
Finger Joint	Unlimited

\*Joints in sidewalks must meet all requirements of Americans with Disabilities Act

For new construction, use only the joint types listed in the preceding table. A typical joint for C.I.P. flat slab bridges is the silicone seal.

Maximum joint width.....	$W_{\text{max}} := 2 \cdot \text{in}$
Minimum joint width at 70° F.....	$W_{\text{min}} := \frac{5}{8} \cdot \text{in}$
Proposed joint width at 70° F.....	$W := 1 \cdot \text{in}$

**Movement [SDG 2015, 6.4.2]**

For concrete structures, the movement is based on the greater of the following combinations:

Movement from the combination of temperature fall, creep, and shrinkage.....

$$\Delta x_{\text{fall}} = \Delta x_{\text{temperature.fall}} \dots + \Delta x_{\text{creep.shrinkage}}$$

*(Note: A temperature rise with creep and shrinkage is not investigated since they have opposite effects).*

Movement from factored effects of temperature.....

$$\Delta x_{\text{rise}} = 1.15 \cdot \Delta x_{\text{temperature.rise}}$$

$$\Delta x_{\text{fall}} = 1.15 \cdot \Delta x_{\text{temperature.fall}}$$

*(Note: For concrete structures, the temperature rise and fall ranges are the same).*

**D. Substructure**

**D1. Bent 2 Geometry (Bent 3 similar)**

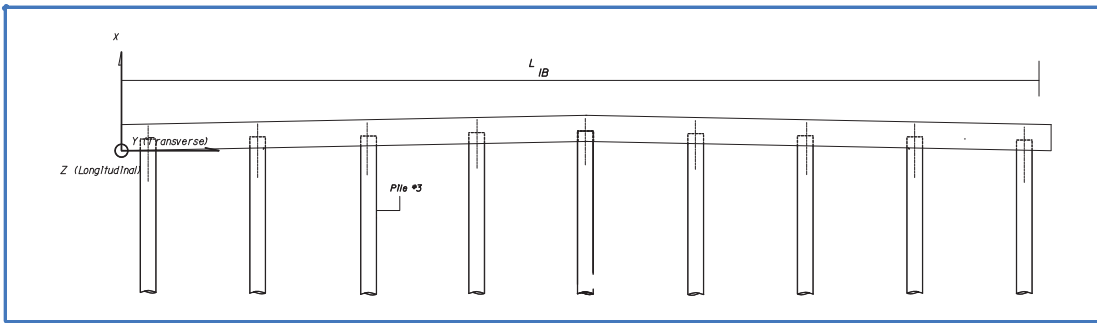

- Depth of intermediate bent cap.....  $h_{cap} := 2.5\text{-ft}$
- Width of intermediate bent cap.....  $b_{cap} := 3.5\text{-ft}$
- Length of intermediate bent cap....  $L := 102.86\text{-ft}$
- Pile Embedment Depth.....  $Pile_{embed} := 12\text{-in}$
- Pile Size.....  $Pile_{size} := 18\text{-in}$
- Length of intermediate bent cap  $L_{cap} := 11\text{ft}$
- Length of edge bent cap.....  $L_{edge.cap} := 1.93\text{ft}$
- Number of spans.....  $N_{cap} := 9$
- Concrete clear cover.....  $c_c = 1.5\text{-in}$

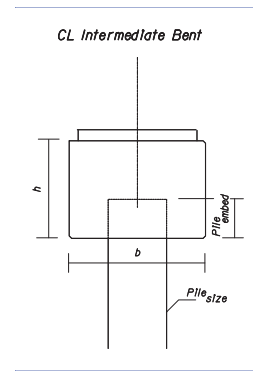

*(Note: For this design example, only the intermediate bent will be evaluated).*

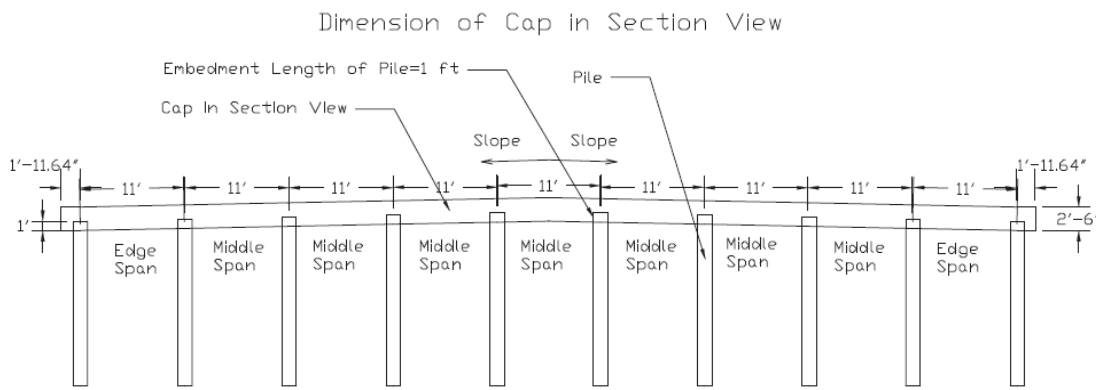

Notes: The Slope of Cap is 0.02 ft/ft

Defined Units



## PROJECT INFORMATION

### Material properties

---

#### Description

This section provides the design input parameters necessary for the superstructure and substructure design.

<b>Page</b>	<b>Contents</b>
16	<b>A. Concrete properties</b> A1. Define Superstructure Concrete A2. Todeschini's Model Approximation for Superstructure Concrete A3. Define Substructure Concrete A4. Todeschini's Model Approximation for Substructure Concrete
19	<b>B. GFRP reinforcement properties</b> B1. Define Flat Slab Reinforcement B2. Define Traffic Barrier Reinforcement B3. Define Bent 2 Cap Reinforcement



## A. Concrete properties

### A1. Define superstructure concrete properties



28-day concrete compressive strength

note: minimum 3400psi

$$f_{c.super} := 4500\text{psi}$$

Concrete tensile strength [ACI 318-14]

$$f_{t.super} := 7.5 \sqrt{f_{c.super} \cdot \text{psi}} = 503.1 \cdot \text{psi}$$

Concrete ultimate strain [AASHTO GFRP 2009, 2.9.2.1]

$$\epsilon_{cu} := 0.003$$

Unit weight of concrete

$$\rho_c := 145\text{pcf}$$

Correction factor for Florida limerock coarse aggregate

$$\Phi_{limerock} := 0.9$$

Concrete modulus of elasticity

$$E_{c.super} := \Phi_{limerock} \cdot 1820 \sqrt{f_{c.super} \cdot \text{ksi}} = 3474.7 \cdot \text{ksi}$$

Stress-block coefficient [ACI 318-14]

$$\beta_{1.super} := \begin{cases} 0.85 & \text{if } f_{c.super} = 4000\text{psi} & = 0.825 \\ 1.05 - 0.05 \cdot \frac{f_{c.super}}{1000\text{psi}} & \text{if } 4000\text{psi} < f_{c.super} < 8000\text{psi} \\ 0.65 & \text{otherwise} \end{cases}$$



### A2. Todeschini's model approximation for superstructure concrete



Compressive strain at peak:

$$\epsilon_{c0.super} := \frac{1.71 \cdot f_{c.super}}{E_{c.super}} = 0.00221$$

Compressive stress at peak:

$$\sigma_{c.super} := 0.9 \cdot \frac{f_{c.super}}{\text{psi}}$$

Stress-strain curve equation:

$$\sigma_{c.super}(\epsilon_c) := \frac{2 \cdot \sigma''_{c.super} \left( \frac{\epsilon_c}{\epsilon_{c0.super}} \right)}{1 + \left( \frac{\epsilon_c}{\epsilon_{c0.super}} \right)^2}$$

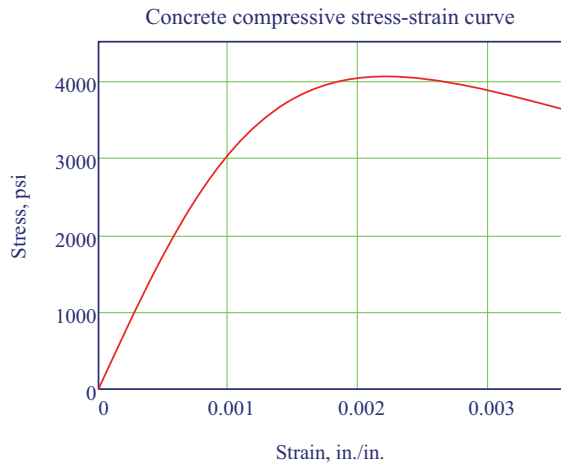

### A3. Define substructure concrete properties



28-day concrete compressive strength

note: minimum 5500psi

$$f'_{c.sub} := 5500\text{psi}$$

Concrete tensile strength [ACI 318-14]

$$f_{r.sub} := 7.5 \sqrt{f'_{c.sub} \cdot \text{psi}} = 556.2 \cdot \text{psi}$$

Concrete ultimate strain [AASHTO GFRP 2009, 2.9.2.1]

$$\epsilon_{cu} = 0.003$$

Unit weight of concrete

$$\rho_c = 145 \cdot \text{pcf}$$

Correction factor for Florida limerock coarse aggregate

$$\Phi_{\text{limerock}} = 0.9$$

Concrete modulus of elasticity

$$E_{c.sub} := \Phi_{limerock} \cdot 1820 \sqrt{f_{c.sub}} \cdot \text{ksi} = 3841.5 \cdot \text{ksi}$$

Stress-block coefficient [ACI 318-14]

$$\beta_{1.sub} := \begin{cases} 0.85 & \text{if } f_{c.sub} = 4000 \text{psi} \\ 1.05 - 0.05 \cdot \frac{f_{c.sub}}{1000 \text{psi}} & \text{if } 4000 \text{psi} < f_{c.sub} < 8000 \text{psi} \\ 0.65 & \text{otherwise} \end{cases} = 0.775$$



#### A4. Todeschini's model approximation for substructure concrete



Compressive strain at peak:

$$\epsilon_{c0.sub} := \frac{1.71 \cdot f_{c.sub}}{E_{c.sub}} = 0.00245$$

Compressive stress at peak:

$$\sigma''_{c.sub} := 0.9 \cdot \frac{f_{c.sub}}{\text{psi}}$$

Stress-strain curve equation:

$$\sigma_{c.sub}(\epsilon_c) := \frac{2 \cdot \sigma''_{c.sub} \cdot \left( \frac{\epsilon_c}{\epsilon_{c0.sub}} \right)}{1 + \left( \frac{\epsilon_c}{\epsilon_{c0.sub}} \right)^2}$$

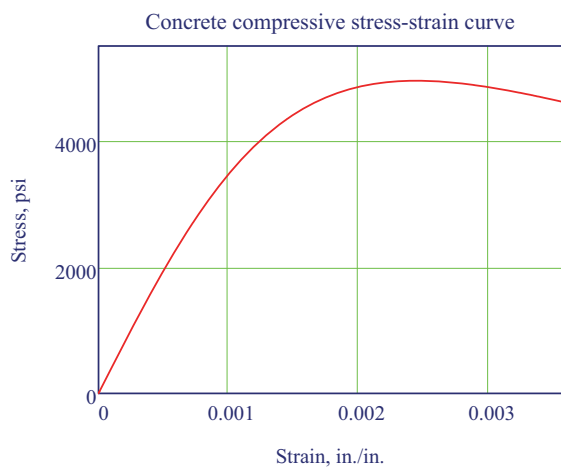

## B. Reinforcement properties

Reinforcement type according to [AC454 2014].  
 Manufacturers provide material properties exceeding [AC454 2014] minimum requirements.  
 Guaranteed values provided by manufacturer are adopted for design purposes.

### B1. Define flat slab reinforcement



Flat slab primary reinforcement bar size.  
 (GFRP straight bars)

$No_{pr.slab} = 10$

$No_{pr.slab} :=$

4
5
6
7
8
9
10

Flat slab secondary reinforcement bar size.  
 (GFRP straight bars)

$No_{sec.slab} = 6$

$No_{sec.slab} :=$

4
5
6
7
8
9
10



### B2. Define traffic barrier reinforcement



Traffic barrier transverse reinforcement bar size.  
 (GFRP bent bars)

$No_{tr.barrier} = 6$

$No_{tr.barrier} :=$

4
5
6
7
8

Traffic barrier longitudinal reinforcement bar size.  
 (GFRP straight bars)

$No_{lg.barrier} = 6$

$No_{lg.barrier} :=$

4
5
6
7
8
9
10

Traffic barrier shear reinforcement bar size.  
 (GFRP U bent bars)



$No_{sh.barrier} :=$

4
5

$No_{sh.barrier} = 4$

### B3. Define Bent 2 Cap reinforcement



Cap primary reinforcement bar size.  
 (GFRP straight bars)

$No_{pr.cap} = 10$

$No_{pr.cap} :=$

4
5
6
7
8
9
10

Cap shear reinforcement bar size.  
 (GFRP U bent bars)

$No_{sh.cap} = 4$

$No_{sh.cap} :=$

4
5



### Reinforcement Properties

This section contains physical and mechanical properties of reinforcement, such as diameter, area, modulus of elasticity and design strength.





## SUPERSTRUCTURE DESIGN

### Flat Slab Design Loads

---

#### References (links to other mathcad files)

 Reference:L:\LRFD\_Design\_Example\_#2A thesis\1.03.Design\_Parameters.xmcd(R)

#### Description

This section provides the design loads for the flat slab superstructure

<b>Page</b>	<b>Contents</b>
21	LRFD Criteria
22	A. Input Variables
23	B. Dead Load Analysis
24	C. Approximate Methods of Analysis - Decks [AASHTO LRFD 2014, 4.6.2]
	C1. Equivalent Strip Widths for Slab-type Bridges [AASHTO LRFD 2014, 4.6.2.3]
	C2. Live Load Analysis
	C3. Limit State Moments and Shears

## LRFD Criteria

**STRENGTH I -** Basic load combination relating to the normal vehicular use of the bridge without wind.

WA = 0 For superstructure design, water load and stream pressure are not applicable.

FR = 0 No friction forces.

$$\text{Strength I} = 1.25 \cdot \text{DC} + 1.50 \cdot \text{DW} + 1.75 \cdot \text{LL} + 0.50 \cdot (\text{TU} + \text{CR} + \text{SH})$$

**STRENGTH II -** Load combination relating to the use of the bridge by Owner-specified special design vehicles, evaluation permit vehicles, or both without wind.

"Permit vehicles are not evaluated in this design example"

**SERVICE I -** Load combination relating to the normal operational use of the bridge with a 55 MPH wind and all loads taken at their nominal values.

BR, WL = 0 For superstructure design, braking forces and wind on live load are not applicable.

CR, SH = 0 Creep and shrinkage is not evaluated in this design example.

$$\text{Service I} = 1.0 \cdot \text{DC} + 1.0 \cdot \text{DW} + 1.0 \cdot \text{LL}$$

**FATIGUE -** Fatigue load combination relating to repetitive gravitational vehicular live load under a single design truck.

$$\text{Fatigue} = 0.75 \cdot \text{LL}$$

**Note:**

- **AASHTO LRFD 2014 C4.6.2.1.6** states that "past practice has been not to check shear in typical decks... It is not the intent to check shear in every deck." In addition, **AASHTO LRFD 2014 5.14.4.1** states that for cast-in-place slab superstructures designed for moment in conformance with **AASHTO LRFD 2014 4.6.2.3**, may be considered satisfactory for shear.
- For this design example, shear will not be investigated. From previous past experience, if the slab thickness is chosen according to satisfy LRFD minimum thickness requirements as per the slab to depth ratios and designed utilizing the distribution strips, shear will not control. If special vehicles are used in the design, shear may need to be investigated.

### A. Input Variables

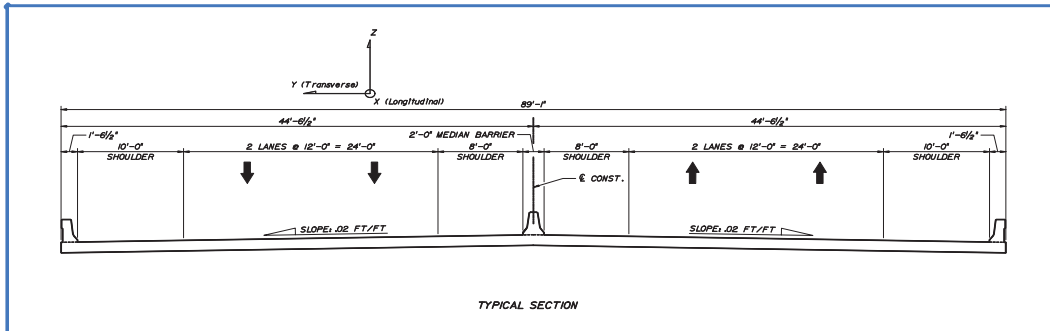

- Bridge design span length.....  $L_{span} = 35 \text{ ft}$
- Thickness of superstructure slab.....  $t_{slab} = 18 \text{ in}$
- Milling surface thickness.....  $t_{mill} = 0 \text{ in}$
- Dynamic Load Allowance.....  $IM = 1.33$
- Bridge skew.....  $Skew = -30 \text{ deg}$

## B. Dead Load Analysis

There are numerous programs and charts that can be used to calculate the dead load moments on this type of structure. For the dead load calculation, the influence line coordinates for a uniform load applied on the structure is utilized. The influence coordinates are based on AISC's Moments, Shears and Reactions for Continuous Highway Bridges, published 1966.

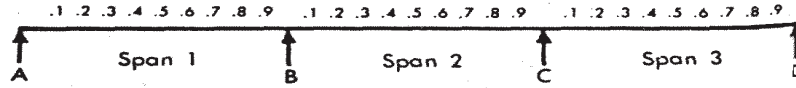

Bridge Length =	105	ft
Bridge Width =	89.1	ft
# of Traffic Barriers =	2	each
# of Median Barriers =	1	each
No. of spans =	3	each
End Span Lengths =	35.000	ft
Interior Span Lengths =	35.000	
Concrete Weight (DC) =	0.150	kcf
Traffic Railing Barrier (DC) =	0.418	klf
Median Barrier (DC) =	0.483	klf
Wearing Surface and/or fws (DW) =	0.015	ksf
Barriers & Median (DC) =	0.0148	ksf = [(2 x 0.418 klf) + (1 x 0.483 klf)] / 89.1 ft = 0.0148 ksf
18 in = Thickness	Bridge Slab (DC) =	0.225 ksf = 18 in. / 12) x 0.15 kcf = 0.225 ksf
Additional Misc Loads (DC) =	0.000	
Components & Attachments (DC) =	0.240	ksf = 0.0148 ksf + 0.225 ksf + 0 = 0.24 ksf

span ratio = 1.00  
Use tables 1.0 and 1.1

(From "Moments, Shears and Reactions for Continuous Highway Bridges" published by AISC, 1966)

Pt.	AISC Table	Influence Line Coordinates		DC MOMENTS	DW MOMENTS	DC SHEARS	DW SHEARS
		1.0	1.1	(FT-KIP/FT)	(FT-KIP/FT)	(KIP/FT)	(KIP/FT)
0	A	0.0000	0.0000	0.0	0.0	3.4	0.2
1	0.1	0.0350	0.0340	10.3	0.6	2.5	0.2
2	0.2	0.0600	0.0580	17.6	1.1	1.7	0.1
3	0.3	0.0750	0.0720	22.0	1.4	0.8	0.1
4	0.4	0.0800	0.0760	23.5	1.5	0.0	0.0
5	0.5	0.0750	0.0700	22.0	1.4	-0.8	-0.1
6	0.6	0.0600	0.0540	17.6	1.1	-1.7	-0.1
7	0.7	0.0350	0.0280	10.3	0.6	-2.5	-0.2
8	0.8	0.0000	-0.0080	0.0	0.0	-3.4	-0.2
9	0.9	-0.0450	-0.0540	-13.2	-0.8	-4.2	-0.3
10	B	-0.1000	-0.1100	-29.4	-1.8	-5.0	-0.3
	B	-0.1000	-0.1100	-29.4	-1.8	4.2	0.3
11	1.1	-0.0550	-0.0555	-16.2	-1.0	3.1	0.2
12	1.2	-0.0200	-0.0132	-5.9	-0.4	2.1	0.1
13	1.3	0.0050	0.0171	1.5	0.1	1.0	0.1
14	1.4	0.0200	0.0352	5.9	0.4	0.0	0.0
15	1.5	0.0250	0.0413	7.3	0.5	0.0	0.0
16	1.6	0.0200	0.0352	5.9	0.4	-0.7	0.0
17	1.7	0.0050	0.0171	1.5	0.1	-1.4	-0.1
18	1.8	-0.0200	-0.0132	-5.9	-0.4	-2.1	-0.1
19	1.9	-0.0550	-0.0555	-16.2	-1.0	-2.8	-0.2
20	C	-0.1000	-0.1100	-29.4	-1.8	-4.2	-0.3
	C	-0.1000	-0.1100	-29.4	-1.8	5.0	0.3
21	2.1	-0.0450	-0.0540	-13.2	-0.8	4.2	0.3
22	2.2	0.0000	-0.0080	0.0	0.0	3.4	0.2
23	2.3	0.0350	0.0280	10.3	0.6	2.5	0.2
24	2.4	0.0600	0.0540	17.6	1.1	1.7	0.1
25	2.5	0.0750	0.0700	22.0	1.4	0.8	0.1
26	2.6	0.0800	0.0760	23.5	1.5	0.0	0.0
27	2.7	0.0750	0.0720	22.0	1.4	-0.8	-0.1
28	2.8	0.0600	0.0580	17.6	1.1	-1.7	-0.1
29	2.9	0.0350	0.0340	10.3	0.6	-2.5	-0.2
30	D	0.0000	0.0000	0.0	0.0	-3.4	-0.2



**C. Approximate Methods of Analysis - Decks [AASHTO LRFD 2014, 4.6.2]**

**C1. Equivalent Strip Widths for Slab-type Bridges [AASHTO LRFD 2014, 4.6.2.3]**

The superstructure is designed on a per foot basis longitudinally. However, in order to distribute the live loads, equivalent strips of flat slab deck widths are calculated. The moment and shear effects of a single HL-93 vehicle or multiple vehicles are divided by the appropriate equivalent strip width. The equivalent strips account for the transverse distribution of LRFD wheel loads. This section is only applicable for spans greater than **15 feet**.

**One design lane**

The equivalent width of longitudinal strips per lane for both shear and moment with one lane loaded:

$$E = 10 + 5.0 \sqrt{L_1 \cdot W_1}$$

where

$L_1$ , modified span length taken equal to the lesser of the actual span or 60 feet.....

$$L_1 := \min(L_{\text{span}}, 60.0 \cdot \text{ft})$$

$$L_1 = 35 \text{ ft}$$

$W_1$ , modified edge to edge width of bridge taken as the lesser of the actual width,  $W_{\text{bridge}}$ , or 30 feet for single lane loading.....

$$W_1 := \min(W_{\text{bridge}}, 30.0 \cdot \text{ft})$$

$$W_1 = 30 \text{ ft}$$

The equivalent distribution width for one lane loaded is given as.....

$$E_{\text{onelane}} := \left( 10 + 5.0 \sqrt{\frac{L_1}{\text{ft}} \frac{W_1}{\text{ft}}} \right) \cdot \text{in}$$

$$E_{\text{onelane}} = 14.3 \cdot \text{ft} \quad \text{or} \quad E_{\text{onelane}} = 14.3 \text{ ft}$$

**Two or more design lanes**

The equivalent width of longitudinal strips per lane for both shear and moment with more than one lane loaded:

$$E = 84 + 1.44 \sqrt{L_1 \cdot W_1} \leq \frac{12.0W}{N_L}$$

where

$L_1$ , modified span length.....

$$L_1 = 35 \text{ ft}$$

$W_1$ , modified edge to edge width of bridge taken as the lesser of the actual width,  $W_{\text{bridge}}$ , or 60 feet for multilane loading.....

$$W_1 := \min(W_{\text{bridge}}, 60.0 \cdot \text{ft})$$

$$W_1 = 60 \text{ ft}$$

Since the bridge is crowned and the full width of the bridge is used in the equivalent distribution width equation, the number of design lanes should include both roadways. Therefore, number of design lanes.....

$$N_L := 2 \cdot N_{\text{lanes}}$$

$$N_L = 6$$

The equivalent distribution width for more than one lane loaded is given as.....  $E_{TwoLane} := \min \left[ \left( 84 + 1.44 \sqrt{\frac{L_1}{ft} \frac{W_1}{ft}} \right), \frac{12.0 \left( \frac{W_{bridge}}{ft} \right)}{N_L} \right] \cdot \text{in}$

$E_{TwoLane} = 150.0 \cdot \text{in}$  or  $E_{TwoLane} = 12.5 \text{ ft}$

The design strip width to use would be the one that causes the maximum effects. In this case, it would be the minimum value of the two.....  $E := \min(E_{onelane}, E_{TwoLane})$

$E = 150.0 \cdot \text{in}$  or  $E = 12.5 \text{ ft}$

**Skew modification**

For skewed bridges, the longitudinal force effects (moments only) may be reduced by a factor r.....  $r := \min(1.05 - 0.25 \cdot \tan(|\text{Skew}|), 1.00)$

$r = 0.91$

*(Note: For this design example, the skew modification will not be applied in order to design for more conservative moment values)*

**C2. Live Load Analysis**

Determine the live load moments and shears due to one HL-93 vehicle on the continuous flat slab structure. The design live loads will consists of the HL-93 vehicle moments, divided by the appropriate equivalent strip widths. This will result in a design live load per foot width of flat slab.

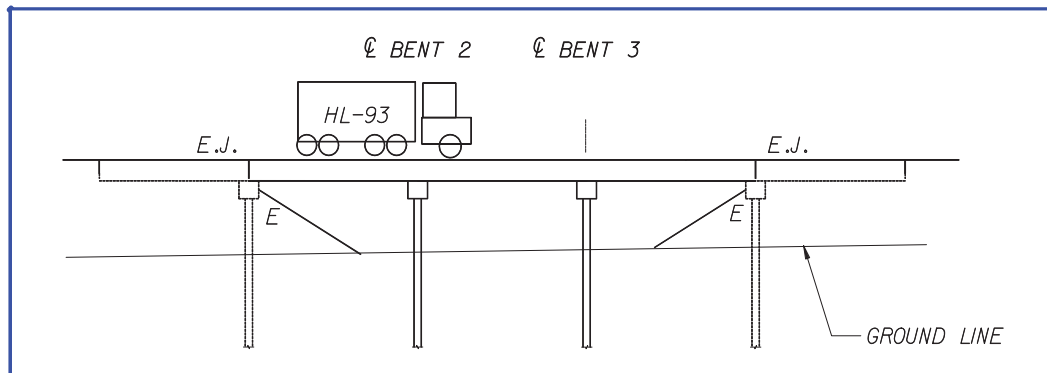

In order to calculate the live load moments and shears, the FDOT MathCad program "LRFD Live Load Generator, English, v2.1".

**Read Live Load results from files generated by FDOT Program**

The files generated by the program are as follows: ("service1.txt" "fatigue.txt" ). These files are output files that can be used to transfer information from one file to another via read and write commands in MathCad.

The files can be view by clicking on the following icons:

To data is read from the file created by FDOT MathCad program "LRFD Live Load Generator" program.

The values for Strength I can be obtained by multiplying by the appropriate load case factor. The values of Live Load for the HL-93 loads are as follows:

HL-93 Live Load Envelopes								
Pt.	(10th points) "X" distance	Service I		Strength I		Fatigue		
		+M	-M	+M	-M	+M	-M	M <sub>Range</sub>
0	0	0.0	0.0	0.0	0.0	0.0	0.0	0.0
1	3.5	220.9	-23.0	386.6	-40.2	92.7	-5.8	98.5
2	7	369.4	-46.0	646.5	-80.4	156.0	-11.6	167.5
3	10.5	460.8	-69.0	806.4	-120.7	195.5	-17.3	212.8
4	14	495.0	-92.1	866.3	-161.1	209.2	-23.1	232.3
5	17.5	482.8	-115.0	844.9	-201.3	198.4	-28.9	227.3
6	21	433.1	-137.7	757.9	-241.0	171.1	-34.7	205.8
7	24.5	340.6	-161.5	596.1	-282.6	138.0	-40.5	178.5
8	28	213.3	-184.5	373.3	-322.9	94.9	-59.1	154.0
9	31.5	88.1	-232.9	154.2	-407.6	39.8	-117.9	157.7
10	35	76.1	-383.5	133.2	-671.1	27.0	-186.9	213.8
11	38.5	89.5	-275.7	156.7	-482.5	48.7	-122.2	170.8
12	42	215.3	-228.7	376.8	-400.2	95.6	-81.2	176.8
13	45.5	322.4	-196.6	564.2	-344.1	124.3	-67.5	191.8
14	49	386.1	-165.5	675.7	-289.6	136.6	-54.0	190.5
15	52.5	403.4	-133.9	706.0	-234.3	134.4	-40.5	174.9
16	56	386.1	-165.5	675.7	-289.6	136.6	-54.0	190.5
17	59.5	322.4	-196.6	564.2	-344.1	124.3	-67.5	191.8
18	63	215.3	-228.7	376.8	-400.2	95.6	-81.2	176.8
19	66.5	90.1	-275.7	157.6	-482.5	48.7	-122.2	170.8
20	70	76.1	-383.0	133.2	-670.3	27.0	-186.9	213.8
21	73.5	87.5	-232.9	153.1	-407.6	39.8	-117.9	157.7
22	77	213.3	-184.5	373.3	-322.9	94.9	-59.1	154.0
23	80.5	340.6	-161.5	596.1	-282.6	138.0	-40.5	178.5
24	84	433.1	-137.7	757.9	-241.0	171.1	-34.7	205.8
25	87.5	482.8	-115.0	844.9	-201.3	198.4	-28.9	227.3
26	91	495.0	-92.1	866.3	-161.1	209.2	-23.1	232.3
27	94.5	460.8	-69.0	806.4	-120.7	195.5	-17.3	212.8
28	98	369.4	-46.0	646.5	-80.4	156.0	-11.6	167.5
29	101.5	220.9	-23.0	386.6	-40.2	92.7	-5.8	98.5
30	105	0.0	0.0	0.0	0.0	0.0	0.0	0.0

The design values can be obtained by dividing the moments by the distribution width,  $E = 12.5\text{-ft}$ ; for fatigue,  $E_{\text{onelane}} = 14.3\text{ ft}$

Design Live Load Envelopes						E = 12,5 ft		
						E <sub>fatigue</sub> = 14,3 ft		
Joint	(10th points) "X" distance	Service I		Strength I		Fatigue		
		+M	-M	+M	-M	+M	-M	M <sub>Range</sub>
0	0	0,0	0,0	0,0	0,0	0,0	0,0	0,0
1	3,5	17,7	-1,8	30,9	-3,2	6,4	-0,4	6,8
2	7	29,6	-3,7	51,7	-6,4	10,8	-0,8	11,6
3	10,5	36,9	-5,5	64,5	-9,7	13,6	-1,2	14,8
4	14	39,6	-7,4	69,3	-12,9	14,5	-1,6	16,1
5	17,5	38,6	-9,2	67,6	-16,1	13,8	-2,0	15,8
6	21	34,6	-11,0	60,6	-19,3	11,9	-2,4	14,3
7	24,5	27,2	-12,9	47,7	-22,6	9,6	-2,8	12,4
8	28	17,1	-14,8	29,9	-25,8	6,6	-4,1	10,7
9	31,5	7,1	-18,6	12,3	-32,6	2,8	-8,2	10,9
10	35	6,1	-30,7	10,7	-53,7	1,9	-13,0	14,8
11	38,5	7,2	-22,1	12,5	-38,6	3,4	-8,5	11,8
12	42	17,2	-18,3	30,1	-32,0	6,6	-5,6	12,3
13	45,5	25,8	-15,7	45,1	-27,5	8,6	-4,7	13,3
14	49	30,9	-13,2	54,1	-23,2	9,5	-3,7	13,2
15	52,5	32,3	-10,7	56,5	-18,7	9,3	-2,8	12,1
16	56	30,9	-13,2	54,1	-23,2	9,5	-3,7	13,2
17	59,5	25,8	-15,7	45,1	-27,5	8,6	-4,7	13,3
18	63	17,2	-18,3	30,1	-32,0	6,6	-5,6	12,3
19	66,5	7,2	-22,1	12,6	-38,6	3,4	-8,5	11,8
20	70	6,1	-30,6	10,7	-53,6	1,9	-13,0	14,8
21	73,5	7,0	-18,6	12,2	-32,6	2,8	-8,2	10,9
22	77	17,1	-14,8	29,9	-25,8	6,6	-4,1	10,7
23	80,5	27,2	-12,9	47,7	-22,6	9,6	-2,8	12,4
24	84	34,6	-11,0	60,6	-19,3	11,9	-2,4	14,3
25	87,5	38,6	-9,2	67,6	-16,1	13,8	-2,0	15,8
26	91	39,6	-7,4	69,3	-12,9	14,5	-1,6	16,1
27	94,5	36,9	-5,5	64,5	-9,7	13,6	-1,2	14,8
28	98	29,6	-3,7	51,7	-6,4	10,8	-0,8	11,6
29	101,5	17,7	-1,8	30,9	-3,2	6,4	-0,4	6,8
30	105	0,0	0,0	0,0	0,0	0,0	0,0	0,0

$i := 0 \dots \text{rows}(X) - 1$

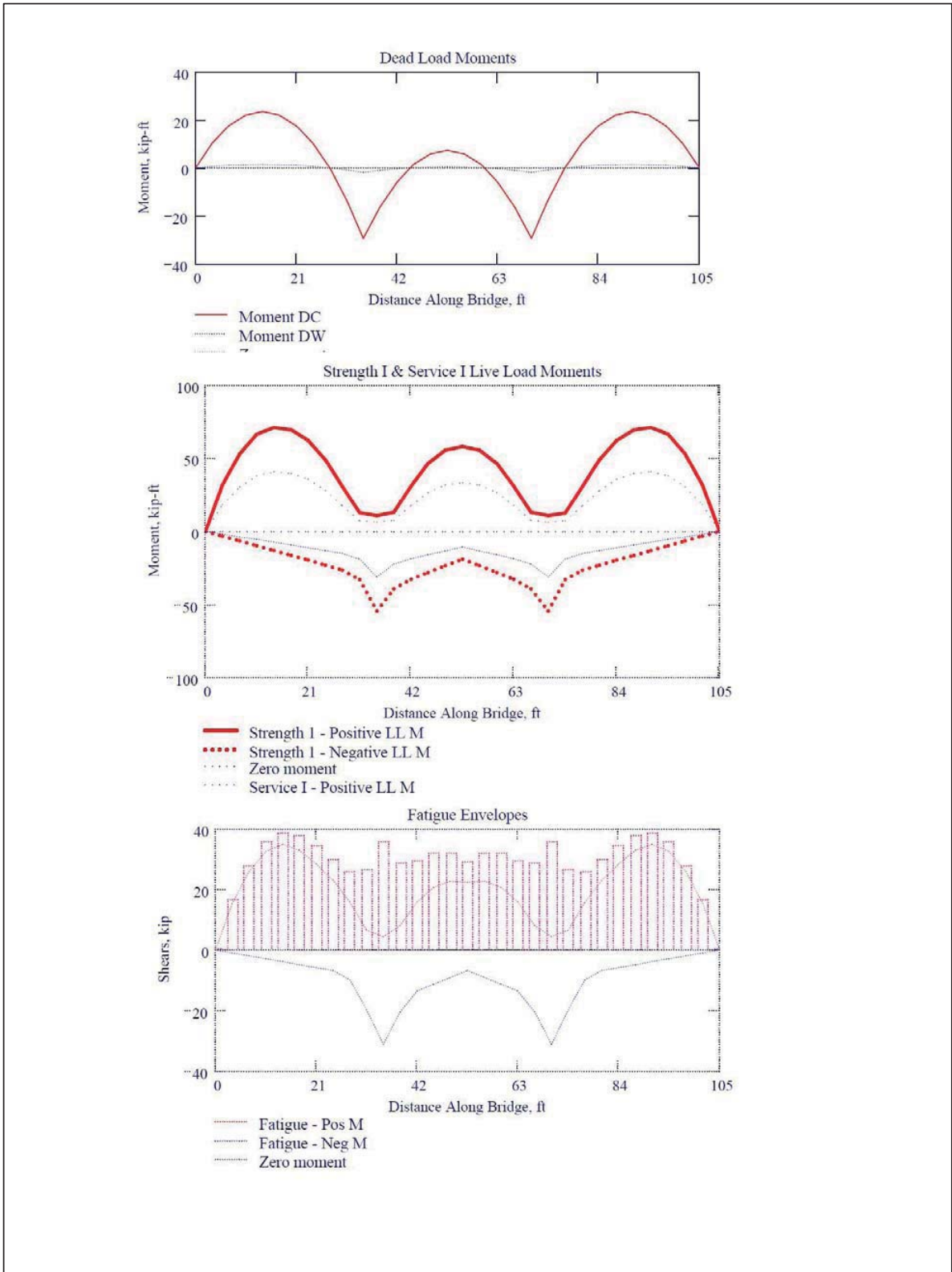

**C3. Limit State Moments and Shears**

The service and strength limit states used to design the section are calculated as follows:

Limit State Design Loads									
Pt.	"X" dist	Service I 1.0DC + 1.0DW + 1.0LL		Strength I 1.25DC + 1.50DW + 1.75LL		Fatigue 1.0DC + 1.0DW + 1.5LL M <sub>Range</sub> = 0.75LL ; -M <sub>min</sub> = 0.75LL			
		+M	-M	+M	-M	+M	-M	M <sub>Range</sub>	-M <sub>min</sub>
0	0	0,0	0,0	0,0	0,0	0,0	0,0	0,0	0,0
1	3,5	28,6	9,1	44,7	10,6	20,6	10,3	6,8	-0,4
2	7	48,3	15,1	75,4	17,3	35,0	17,5	11,6	-0,8
3	10,5	60,3	17,9	94,1	20,0	43,8	21,6	14,8	-1,2
4	14	64,6	17,6	100,9	18,7	46,7	22,6	16,1	-1,6
5	17,5	62,0	14,2	97,2	13,5	44,1	20,4	15,8	-2,0
6	21	53,4	7,7	84,3	4,4	36,5	15,1	14,3	-2,4
7	24,5	38,2	-2,0	61,5	-8,8	25,3	6,7	12,4	-2,8
8	28	17,1	-14,8	29,9	-25,8	9,9	-6,1	10,7	-4,1
9	31,5	-7,0	-32,7	-5,4	-50,4	-9,9	-26,3	10,9	-8,2
10	35	-25,1	-61,9	-28,8	-93,2	-28,4	-50,7	14,8	-13,0
11	38,5	-10,0	-39,2	-9,2	-60,3	-12,1	-29,9	11,8	-8,5
12	42	11,0	-24,5	22,2	-39,9	3,7	-14,7	12,3	-5,6
13	45,5	27,4	-14,2	47,1	-25,6	14,5	-5,5	13,3	-4,7
14	49	37,1	-7,0	61,9	-15,3	20,5	0,6	13,2	-3,7
15	52,5	40,1	-2,9	66,3	-8,9	21,8	3,6	12,1	-2,8
16	56	37,1	-7,0	61,9	-15,3	20,5	0,6	13,2	-3,7
17	59,5	27,4	-14,2	47,1	-25,6	14,5	-5,5	13,3	-4,7
18	63	11,0	-24,5	22,2	-39,9	3,7	-14,7	12,3	-5,6
19	66,5	-10,0	-39,2	-9,1	-60,3	-12,1	-29,9	11,8	-8,5
20	70	-25,1	-61,9	-28,8	-93,1	-28,4	-50,7	14,8	-13,0
21	73,5	-7,0	-32,7	-5,5	-50,4	-9,9	-26,3	10,9	-8,2
22	77	17,1	-14,8	29,9	-25,8	9,9	-6,1	10,7	-4,1
23	80,5	38,2	-2,0	61,5	-8,8	25,3	6,7	12,4	-2,8
24	84	53,4	7,7	84,3	4,4	36,5	15,1	14,3	-2,4
25	87,5	62,0	14,2	97,2	13,5	44,1	20,4	15,8	-2,0
26	91	64,6	17,6	100,9	18,7	46,7	22,6	16,1	-1,6
27	94,5	60,3	17,9	94,1	20,0	43,8	21,6	14,8	-1,2
28	98	48,3	15,1	75,4	17,3	35,0	17,5	11,6	-0,8
29	101,5	28,6	9,1	44,7	10,6	20,6	10,3	6,8	-0,4
30	105	0,0	0,0	0,0	0,0	0,0	0,0	0,0	0,0

<-Maximum positive moment and corresponding fatigue values

<-Maximum negative moment and corresponding fatigue values

Maximum negative Moments =	-61,9	-93,2	46,7	16,1	-1,6
Maximum positive Moments =	64,6	100,9	-50,7	14,8	-13,0



▢ Defined Units



## SUPERSTRUCTURE DESIGN

### GFRP-Reinforced Flat Slab Design

#### References (links to other Mathcad files)

-  Reference:L:\LRFD\_Design\_Example\_#2A thesis\1.03.Design\_Parameters.xmcd(R)
-  Reference:L:\LRFD\_Design\_Example\_#2A thesis\1.04.Material\_Properties.xmcd(R)
-  Reference:L:\LRFD\_Design\_Example\_#2A thesis\2.01.Flat\_Slab\_Design\_Loads.xmcd(R)

#### Description

This section provides the design for the GFRP-reinforced flat slab superstructure.

<b>Page</b>	<b>Contents</b>
31	<b>A. Input Variables</b>
32	<b>B. Design of Primary Reinforcement</b>
	<b>B1. Data Recall</b>
	<b>B2. Select Primary Reinforcement and Limits</b>
	<b>B3. Negative Moment Region - Flexural Strength at Support</b>
	<b>B4. Development Length at Support</b>
	<b>B5. Positive Moment Region - Flexural Strength at Middle Span</b>
	<b>B6. Development Length at Middle Span</b>
	<b>B7. Reinforcement Splices</b>
40	<b>C. Shear Verification</b>
41	<b>D. Crack Width Verification</b>
	<b>D1. Data Recall</b>
	<b>D2. Support</b>
	<b>D3. Middle Span</b>
44	<b>E. Fatigue and Creep Rupture</b>
	<b>E1. Data Recall</b>
	<b>E2. Support</b>
	<b>E2. Middle Span</b>
46	<b>F. Secondary Reinforcement</b>
	<b>F1.Data Recall</b>
	<b>F2.Reinforcement Distribution</b>
47	<b>G. Shrinkage and Temperature Reinforcement</b>
	<b>G1.Data Recall</b>
	<b>G2.Shrinkage and Temperature Reinforcement</b>
49	<b>H. Deflection Verification</b>
52	<b>I. Summary of Provided Reinforcement and Detailing</b>

## A. Input Variables



Maximum positive moment and corresponding fatigue values

Service	$M_{\text{pos}} := 64.6\text{ft}\cdot\text{kip}$
Strength	$M_{\text{r,pos}} := 100.9\text{ft}\cdot\text{kip}$
Fatigue	$M_{\text{fatigue,pos}} := 46.7\text{ft}\cdot\text{kip}$
	$M_{\text{rang,pos}} := 16.1\text{ft}\cdot\text{kip}$
	$M_{\text{min,pos}} := -1.6\text{ft}\cdot\text{kip}$
Live Load Only	$M_{\text{sPos}} := 39.6\text{ft}\cdot\text{kip}$

Maximum negative moment and corresponding fatigue values

Service	$M_{\text{neg}} := 61.9\text{ft}\cdot\text{kip}$
Strength	$M_{\text{r,neg}} := 93.2\text{ft}\cdot\text{kip}$
Fatigue	$M_{\text{fatigue,neg}} := 50.7\text{ft}\cdot\text{kip}$
	$M_{\text{rang,neg}} := 14.8\text{ft}\cdot\text{kip}$
	$M_{\text{min,neg}} := -13\text{ft}\cdot\text{kip}$
Live Load Only	$M_{\text{sNeg}} := 30.1\text{ft}\cdot\text{kip}$



DC represents the dead load of components & attachment, and DW represents dead load of wearing surface.

$$DC := 0.24\text{klf}$$

$$DW := 0.015\text{klf}$$

For negative moment between points of contraflexure under a uniform load on all spans, and reaction at interior piers only, 90 percent of the effect of two design trucks spaced a minimum of 50.0 ft between the lead axle of one truck and the rear axle of the other truck, combined with 90 percent of the effect of the design lane load. The distance between the 32.0-kip axles of each truck shall be taken as 14.0 ft. The two design trucks shall be placed in adjacent spans to produce maximum force effects. Flat slab is assumed to support all wheels of truck.

[ AASHTO LRFD 2014, 3.6.1.3]

$$\text{Lane Load } LL_{\text{lane}} \quad LL_{\text{lane}} := 0.64 \frac{\text{kip}}{\text{ft}} \quad [\text{AASHTO LRFD 2014, 3.6.1.2.4}]$$

Truck Load  $LL_{\text{truck-axis@i}}$ , i can be 1, 2 and 3

$$LL_{\text{TruckAxisAt1}} := 8\text{kip} \quad [\text{AASHTO LRFD 2014, 3.6.1.2.2}]$$

$$LL_{\text{TruckAxisAt2}} := 32\text{kip}$$

$$LL_{\text{TruckAxisAt3}} := 32\text{kip}$$



Note: The distance between truck axis 1 and 2 is 14 ft and the distance between axis 2 and 3 can range from 14 ft to 30 ft. However, [AASHTO LRFD 2014 3.6.1.3.1] states the distance between the 32.0-kip axles of one truck shall be taken as 14.0 ft in order to obtain the maximum load effect.

$d_{\text{axisbtw1and2}} := 14\text{ft}$  Distance between axis 1 and 2 [AASHTO LRFD 2014, 3.6.1.3.1]

$d_{\text{axisbtw2and3}} := 14\text{ft}$  Distance between axis 2 and 3

Based on influence line analysis of 3-span continuous beam, the maximum shear will occur at right or left sides of support B based on Table 3.0A in AISC Moments Shears and Reactions for Continuous Highway Bridge.

$V_{\text{rightB}} := 15.8\text{kip}$

$V_{\text{leftB}} := -6.8\text{kip}$

$V_{\text{rightC}} := -10\text{kip}$

$V_{\text{max}} := \max(|V_{\text{rightB}}|, |V_{\text{leftB}}|, |V_{\text{rightC}}|) = 15.8\text{kip}$

Therefore, the ultimate shear in  $d=[15.875\text{in} + \text{half of cap width (42 in)}]$  from right of support B  $V_{\text{rightB}_d}$

$$V_{\text{rightB}_d} := \frac{\left(L_{\text{span}} - 15.88\text{in} - \frac{42\text{in}}{2}\right) \cdot (15.8\text{kip} + |V_{\text{rightC}}|)}{L_{\text{span}}} - |V_{\text{rightC}}| = 13.5\text{kip}$$



## B. Design of Primary Reinforcement

### B1.Data recall (section B of chapter 1.04)



$\text{diam}_{\text{No.pr.slab}} = 1.25\text{-in}$

Diameter of deck primary GFRP reinforcement

$\text{area}_{\text{No.pr.slab}} = 1.23\text{-in}^2$

Area of deck primary GFRP reinforcement

$E_{f\text{No.pr.slab}} = 7142\text{-ksi}$

Modulus of elasticity of deck primary GFRP reinforcement

$f_{fu\text{No.pr.slab}} = 101.3\text{-ksi}$

Tensile strength of deck primary reinforcement for product certification as reported by GFRP manufacturer [AASHTO GFRP 2009, 2.6.1.2]

$f_{fd.\text{pr.slab}} = 70.9\text{-ksi}$

Design strength of deck primary reinforcement considering reduction for service environment [AASHTO GFRP 2009, 2.6.1.2-1]

$\epsilon_{fu\text{No.pr.slab}} = 1.5\%$

Tensile strain of deck primary reinforcement for product certification as reported by GFRP manufacturer [AASHTO GFRP 2009, 2.6.1.2]

$\epsilon_{fd\text{No.pr.slab}} = 1.1\%$

Design strain of deck primary reinforcement reinforcement considering reduction for service environment [AASHTO GFRP 2009, 2.6.1.2]



### B2. Select primary reinforcement and limits



#### Preliminary GFRP reinforcement

The failure mode depends on the amount of FRP reinforcement. If  $\rho_f$  is larger than the balanced reinforcement ratio,  $\rho_{fb}$ , then concrete crushing is the failure mode. If  $\rho_f$  is smaller than the balanced reinforcement ratio,  $\rho_{fb}$ ,

then FRP rupture is the failure mode.

[AASHTO GFRP 2009, 2.7.4.2-2]

$$\rho_{fb1.slab} := 0.85 \beta_{1.super} \cdot \frac{f_{c.super}}{f_{fd.pr.slab}} \cdot \frac{E_{fNo_{pr.slab}} \cdot \epsilon_{cu}}{E_{fNo_{pr.slab}} \cdot \epsilon_{cu} + f_{fd.pr.slab}} = 0.01$$

The effective reinforcement depth

$$d_{f1.slab} := t_{slab} - c_c - \frac{\text{diam}_{No_{pr.slab}}}{2} = 15.88 \cdot \text{in}$$

This reinforcement ratio corresponds to an area of:

$$A_{f\_req1.slab} := \rho_{fb1.slab} \cdot b_{slab} \cdot d_{f1.slab} = 1.97 \cdot \text{in}^2 \text{ per foot width}$$

The corresponding number of GFRP bars is:

$$N_{f\_req1.slab} := \frac{A_{f\_req1.slab}}{\text{area}_{No_{pr.slab}}} = 1.6$$

The corresponding spacing is:

$$s_{f\_req1.slab} := \frac{b_{slab} - N_{f\_req1.slab} \cdot \text{diam}_{No_{pr.slab}}}{N_{f\_req1.slab}} = 6.2 \cdot \text{in}$$

The trial number of GFRP bars is:

$$N_{f\_bar1.slab} := 3$$

Therefore, the following bar spacing is selected:

$$s_{f\_bar1.slab} := \frac{b_{slab}}{N_{f\_bar1.slab}} = 4 \cdot \text{in}$$

The minimum required clear bar spacing is:

$$s_{f\_min1.slab} := \max(1.5 \cdot \text{in}, 1.5 \cdot \text{diam}_{No_{pr.slab}}) = 1.9 \cdot \text{in}$$

The bar clear spacing is:  $s_{f\_bar1.slab} - \text{diam}_{No_{pr.slab}} = 2.8 \cdot \text{in}$

$$\text{Check\_BarSpacing1} := \begin{cases} \text{"VERIFIED"} & \text{if } s_{f\_bar1.slab} - \text{diam}_{No_{pr.slab}} \geq s_{f\_min1.slab} \\ \text{"TOO MANY BARS"} & \text{otherwise} \end{cases}$$

$$\text{Check\_BarSpacing1} = \text{"VERIFIED"}$$

The area of FRP reinforcement is:

$$A_{f1.slab} := N_{f\_bar1.slab} \cdot \text{area}_{No_{pr.slab}} = 3.68 \cdot \text{in}^2$$

The FRP reinforcement ratio is:

$$\rho_{f1.slab} := \frac{A_{f1.slab}}{b_{slab} \cdot d_{f1.slab}} = 0.019$$

#### Limit for Reinforcement-Minimum Reinforcement

[AASHTO GFRP 2009, 2.9.3.3-1]

$$A_{f.min.slab} := \max(0.33 \text{ksi}, 0.16 \cdot \sqrt{f_{c.super} \text{ksi}}) \cdot \frac{b_{slab} \cdot d_{f1.slab}}{f_{fd.pr.slab}} = 0.9 \cdot \text{in}^2$$

$$\text{Check\_FlexureMinReinforcement} := \begin{cases} \text{"VERIFIED"} & \text{if } A_{f1.slab} \geq A_{f.min.slab} \\ \text{"NOT VERIFIED"} & \text{otherwise} \end{cases}$$

Check\_FlexureMinReinforcement = "VERIFIED"

The slab using GFRP is chosen to be over-reinforced, which means that failure of the component is initiated by crushing of the concrete. The strength reduction factor  $\phi_{f\_bar1.slab}$  is:

[AASHTO GFRP 2009, 2.9.2.1]

$$\phi_{f\_bar1.slab} := \begin{cases} 0.55 & \text{if } \rho_{f1.slab} \leq \rho_{fb1.slab} \\ 0.3 + 0.25 \cdot \frac{\rho_{f1.slab}}{\rho_{fb1.slab}} & \text{if } \rho_{fb1.slab} \leq \rho_{f1.slab} \leq 1.4 \cdot \rho_{fb1.slab} \\ 0.65 & \text{if } \rho_{f1.slab} \geq 1.4 \cdot \rho_{fb1.slab} \end{cases} = 0.65$$



### B3. Negative moment region - flexural strength at support



$diam_{No_{pr.slab}} = 1.25 \cdot \text{in}$  Diameter of deck primary GFRP reinforcement

$area_{No_{pr.slab}} = 1.23 \cdot \text{in}^2$  Area of deck primary GFRP reinforcement

$N_{f\_bar1.slab} = 3$  Number of GFRP bars per foot width for negative moment

$A_{f1.slab} = 3.7 \cdot \text{in}^2$  Area of GFRP bars per foot width for negative moment

$M_{r,neg} = 93.2 \cdot \text{kip} \cdot \text{ft}$  Maximum negative moment demand

$f_{fd.pr.slab} = 70.9 \cdot \text{ksi}$  Design strength of deck primary reinforcement considering reduction for service environment

The maximum tensile stress in the GFRP is computed:

[AASHTO GFRP 2009, 2.9.3.1-1]

$$f_{f1.slab} := \begin{cases} \sqrt{\frac{[(E_{fNo.pr.slab} \cdot \epsilon_{cu})^2]}{4} + \frac{0.85\beta_{1.super} \cdot f_{c.super}}{\rho_{f1.slab}} E_{fNo.pr.slab} \cdot \epsilon_{cu} - 0.5(E_{fNo.pr.slab} \cdot \epsilon_{cu})} & \text{if } \rho_{f1.slab} \geq \rho_{fb1.sl} \\ f_{fu} & \text{otherwise} \end{cases}$$

$$f_{f1.slab} = 49.4 \cdot \text{ksi}$$

$f_f$  cannot exceed  $f_{fu}$ , therefore, the following has to be checked:

$$\text{CheckMaxStress1} := \begin{cases} \text{"VERIFIED"} & \text{if } f_{f1.slab} \leq f_{fd.pr.slab} \\ \text{"REDUCE BAR SPACING OR INCREASE BAR SIZE"} & \text{otherwise} \end{cases}$$

CheckMaxStress1 = "VERIFIED"

The stress-block depth is computed as per Eq.2.9.3.2.2-2 or Eq.2.9.3.2.2-4 whether  $\rho_f > \rho_{fb}$  or  $\rho_f < \rho_{fb}$ , respectively.

$$a_{f1.slab} := \frac{A_{f1.slab} \cdot f_{f1.slab}}{0.85 \cdot f_{c.super} \cdot b_{slab}} = 3.96 \cdot \text{in} \quad [\text{AASHTO GFRP 2009, 2.9.3.2.2-2}]$$

Neutral axis depth  $c_b$  at balanced strain conditions:

$$c_{b1.slab} := \left( \frac{\epsilon_{cu}}{\epsilon_{cu} + \epsilon_{fdNo.pr.slab}} \right) \cdot d_{f1.slab} = 3.5 \cdot \text{in} \quad [\text{AASHTO GFRP 2009, 2.9.3.2.2-4}]$$

The nominal moment capacity is: [AASHTO GFRP 2009, 2.9.3.2.2-1, 2.9.3.2.2-3]

$$M_{nAASHTO\_1.slab} := \begin{cases} A_{f1.slab} \cdot f_{f1.slab} \cdot \left( d_{f1.slab} - \frac{a_{f1.slab}}{2} \right) & \text{if } \rho_{f1.slab} \geq \rho_{fb1.slab} \\ A_{f1.slab} \cdot f_{f1.slab} \cdot \left( d_{f1.slab} - \frac{\beta_{1.super} \cdot c_{b1.slab}}{2} \right) & \text{otherwise} \end{cases}$$

$$M_{nAASHTO\_1.slab} = 210.6 \cdot \text{kip} \cdot \text{ft}$$



Recall the strength reduction factor for slab:

[AASHTO GFRP 2009, 2.12.1.2.1]

$$\phi_{f\_bar1.slab} = 0.65$$

The design flexural strength is computed as:

$$\phi_{f\_bar1.slab} \cdot M_{nAASHTO\_1.slab} = 137 \cdot \text{kip} \cdot \text{ft}$$

Recall  $M_{r,neg} = 93.2 \cdot \text{kip} \cdot \text{ft}$

$$\text{Check\_SlabFlexureAASHTO\_1} := \begin{cases} \text{"VERIFIED"} & \text{if } \phi_{f\_bar1.slab} \cdot M_{nAASHTO\_1.slab} \geq M_{r,neg} \\ \text{"NOT VERIFIED"} & \text{otherwise} \end{cases}$$

Check\_SlabFlexureAASHTO\_1 = "VERIFIED"



#### B4. Development length at support



At least 1/3 of the total tension reinforcement provided for negative moment at a support shall have an embedment length  $L_{d,neg,min}$  beyond the point of inflection as follows:

[AASHTO GFRP 2009, 2.12.1.2.1]

$$L_{d,neg,min} := \max(d_{f1,slab}, 12 \cdot \text{diam}_{No_{pr,slab}}, 0.0625 \cdot L_{span}) = 26.3 \cdot \text{in}$$

1/3 of reinforcement has an embedment length beyond the point of inflection that is chosen to be 2.5 ft.

Based on the bending moment envelope, the negative moment extends about 12 ft from the support. Therefore, 1/3 of reinforcement for negative moment should have a length 17 ft, distributed 7 ft from the left support B and 10 ft from the right support B. (assuming B is the interior support between the first and second spans). At support C, the length is also 17 ft distributed symmetrically (assuming C is the interior support connecting the second and third spans).

The remaining 2/3 of reinforcement for negative moment are distributed along the entire span of bridge.

Lap splices are covered at end of the flexural design (section B7)



#### B5. Positive moment region - flexural strength at middle span



$\text{diam}_{No_{pr,slab}} = 1.25 \cdot \text{in}$	Diameter of deck primary GFRP reinforcement
$\text{area}_{No_{pr,slab}} = 1.23 \cdot \text{in}^2$	Area of deck primary GFRP reinforcement
$N_{f\_bar1,slab} = 3$	Number of GFRP bars per foot width for positive moment
$A_{f2,slab} := A_{f1,slab} = 3.7 \cdot \text{in}^2$	Area of GFRP bars per foot width for positive moment
$d_{f2,slab} := d_{f1,slab} = 15.9 \cdot \text{in}$	The effective reinforcement depth
$S_{f\_bar2,slab} := s_{f\_bar1,slab} = 4 \cdot \text{in}$	The reinforcing spacing
$M_{r,pos} = 100.9 \cdot \text{kip} \cdot \text{ft}$	Maximum positive moment demand
GFRP reinforcement ratio is:	

$$\rho_{f2.slab} := \frac{A_{f2.slab}}{b_{slab} \cdot d_{f2.slab}} = 0.019$$

The balanced reinforcement ratio,  $\rho_{fb}$  is

[AASHTO GFRP 2009, 2.7.4.2-2]

$$\rho_{fb2.slab} := 0.85\beta_{1.super} \frac{f'_{c.super}}{f_{fd.pr.slab}} \cdot \frac{E_{fNo.pr.slab} \cdot \epsilon_{cu}}{E_{fNo.pr.slab} \cdot \epsilon_{cu} + f_{fd.pr.slab}} = 0.01$$

The maximum tensile stress in the GFRP is:

[AASHTO GFRP 2009, 2.9.3.1-1]

$$f_{f2.slab} := \begin{cases} \sqrt{\frac{(E_{fNo.pr.slab} \cdot \epsilon_{cu})^2}{4} + \frac{0.85\beta_{1.super} \cdot f'_{c.super}}{\rho_{f2.slab}} E_{fNo.pr.slab} \cdot \epsilon_{cu}} - 0.5 E_{fNo.pr.slab} \cdot \epsilon_{cu} & \text{if } \rho_{f2.slab} \geq \rho_{fb2.slab} \\ f_{fd.pr.slab} & \text{otherwise} \end{cases}$$

$$f_{f2.slab} = 49.4 \cdot \text{ksi}$$

$f_f$  cannot exceed  $f_{fu}$  therefore, the following has to be checked:

$$\text{Recall design strength } f_{fd.pr.slab} = 70.9 \cdot \text{ksi}$$

$$\text{CheckMaxStress2} := \begin{cases} \text{"VERIFIED"} & \text{if } f_{f2.slab} \leq f_{fd.pr.slab} \\ \text{"REDUCE BAR SPACING OR INCREASE BAR SIZE"} & \text{otherwise} \end{cases}$$

**CheckMaxStress2 = "VERIFIED"**

The stress-block depth is computed as per Eq.2.9.3.2.2-2 or Eq.2.9.3.2.2-4 whether  $\rho_f > \rho_{fb}$  or  $\rho_f < \rho_{fb}$ , respectively.

$$a_{f2.slab} := \frac{A_{f2.slab} \cdot f_{f2.slab}}{0.85 \cdot f'_{c.super} \cdot b_{slab}} = 3.96 \cdot \text{in} \quad [\text{AASHTO GFRP 2009, 2.9.3.2.2-2}]$$

Neutral axis depth  $c_b$  at balanced strain conditions:

$$c_{b2.slab} := \left( \frac{\epsilon_{cu}}{\epsilon_{cu} + \epsilon_{fdNo.pr.slab}} \right) \cdot d_{f2.slab} = 3.5 \cdot \text{in} \quad [\text{AASHTO GFRP 2009, 2.9.3.2.2-4}]$$

The nominal moment capacity is: [AASHTO GFRP 2009, 2.9.3.2.2-1, 2.9.3.2.2-3]

$$M_{nAASHTO\_2.slab} := \begin{cases} A_{f2.slab} \cdot f_{f2.slab} \cdot \left( d_{f2.slab} - \frac{a_{f2.slab}}{2} \right) & \text{if } \rho_{f2.slab} \geq \rho_{fb2.slab} \\ A_{f2.slab} \cdot f_{f2.slab} \cdot \left( d_{f2.slab} - \frac{\beta_{1.super} \cdot c_{b2.slab}}{2} \right) & \text{otherwise} \end{cases}$$

$$M_{nAASHTO\_2.slab} = 210.6 \cdot \text{kip} \cdot \text{ft}$$

$$\phi_{f\_bar2.slab} := \begin{cases} 0.55 & \text{if } \rho_{f2.slab} \leq \rho_{fb2.slab} \\ 0.30 + 0.25 \cdot \frac{\rho_{f2.slab}}{\rho_{fb2.slab}} & \text{if } \rho_{fb2.slab} < \rho_{f2.slab} < 1.4 \cdot \rho_{fb2.slab} \\ 0.65 & \text{otherwise} \end{cases}$$

$\phi_{f\_bar2.slab} = 0.65$

The design flexural strength, equation, is computed as:

$\phi_{f\_bar2.slab} \cdot M_{nAASHTO\_2.slab} = 137 \cdot \text{kip} \cdot \text{ft}$

Recall  $M_{R.pos} = 101 \cdot \text{kip} \cdot \text{ft}$

$$\text{Check\_SlabFlexureAASHTO\_2} := \begin{cases} \text{"VERIFIED"} & \text{if } \phi_{f\_bar2.slab} \cdot M_{nAASHTO\_2.slab} \geq M_{R.pos} \\ \text{"NOT VERIFIED"} & \text{otherwise} \end{cases}$$

$\text{Check\_SlabFlexureAASHTO\_2} = \text{"VERIFIED"}$

**B6. Development length at middle span**

According to [AASHTO GFRP 2009 2.12.1.2], reinforcement should extend not less than the development length,  $L_{d,pos}$  beyond the point at which it is no longer required to resist flexure. and no more than 50% should be terminated at any section.

$$L_{d,pos} := \max\left(t_{slab}, 15 \cdot \text{diam}_{No_{pr.slab}}, \frac{L_{span}}{20}\right) = 21 \cdot \text{in} \quad [\text{AASHTO GFRP 2009, 2.12.1.2.1}]$$

Therefore, the selected development length  $L_{d,pos,sl}$  is chosen to be 2 ft, which is larger than the required  $L_{d,pos}$

$L_{d,pos,sl} := 2 \text{ft}$

In addition,  $L_{d,pos,sl}$  should also satisfy equation [AASHTO GFRP 2009, 2.12.1.2.2-1]

$$L_{d,pos,max} := \frac{M_{nAASHTO\_1.slab}}{V_{rightB\_d}} + 12 \cdot d_{f1.slab} \quad [\text{AASHTO GFRP 2009, 2.12.1.2.2-1}]$$

$$\text{CheckingDevelopmentLength}_{pos} := \begin{cases} \text{"VERIFIED"} & \text{if } L_{d,pos,sl} \leq L_{d,pos,max} \\ \text{"NOT VERIFIED"} & \text{otherwise} \end{cases}$$

$\text{CheckingDevelopmentLength}_{pos} = \text{"VERIFIED"}$

1/3 of reinforcement has an embedment length beyond the point of inflection that is chosen to be 2 ft.

Based on the bending moment envelope, the positive bending moment in the first and third span extends 18 ft, and along the second span for 11 ft. Therefore, 1/3 of the reinforcement will have a length of 22 ft for

the first and third span, and 15 ft for the second span.

The remaining 2/3 of reinforcement is distributed continuously along the entire span of bridge

Lap splices are covered at end of the flexural design (Section B7).



## B7. Reinforcement Splices



The tension lap splice length ( $L_{sp}$ ) should satisfy AASHTO GFRP 2009 2.12.2.1 and 2.12.4

Development length for deformed bars in tension is defined as  $L_{d,tension}$

Bar location modification factor  $\alpha$ , takes the value of 1 except for bars with more than 12 in of concrete cast below for which a value of 1.5 shall be adopted.  $\alpha$  is 1.5 for negative moment reinforcement while  $\alpha=1$  for positive moment.

$$\alpha_{neg.slabs} := 1.5$$

$$\alpha_{pos.slabs} := 1$$

The calculation for lap splices for negative moment and positive moment is:

[AASHTO GFRP 2009, 2.10.3.1-1]

$$L_{d,tension,neg.slabs} := \text{diam}_{No_{pr.slabs}} \cdot \frac{\left( \alpha_{neg.slabs} \cdot \frac{f_{fl.slabs}}{\sqrt{f_{c.super.psi}}} \right) - 340}{13.6 + \frac{c_c}{\text{diam}_{No_{pr.slabs}}}} = 64.6 \text{ in}$$

$$L_{d,tension,pos.slabs} := \text{diam}_{No_{pr.slabs}} \cdot \frac{\left( \alpha_{pos.slabs} \cdot \frac{f_{fl.slabs}}{\sqrt{f_{c.super.psi}}} \right) - 340}{13.6 + \frac{c_c}{\text{diam}_{No_{pr.slabs}}}} = 33.5 \text{ in}$$

[AASHTO GFRP 2009, 2.12.4 ]

$$L_{sp,neg.req} := \max(12 \text{ in}, 1.3 \cdot L_{d,tension,neg.slabs}) = 84 \text{ in}$$

$$L_{sp,pos.req} := \max(12 \text{ in}, 1.3 \cdot L_{d,tension,pos.slabs}) = 43.5 \text{ in}$$

Therefore, lap splice length  $L_{sp,sl}$  selected is:

$$\text{For negative moment region } L_{sp,neg.sl.slabs} := 92 \text{ in}$$

$$\text{For positive moment region } L_{sp,pos.sl.slabs} := 48 \text{ in}$$

Reduction of splice length for excess of reinforcement [ACI318-14 25.4.10]. It is suggested to adopt a limit of 0.6:

$$\text{area}_{required,pos.slabs} := \frac{M_{r,pos}}{f_{fd,pr.slabs} \left( d_{fl.slabs} - \frac{\beta_{1,super} \cdot c_{b1.slabs}}{2} \right)} = 1.2 \text{ in}^2 \quad [\text{AASHTO GFRP 2009, 2.9.3.2.2-3}]$$



$$\text{area}_{\text{required.neg.slab}} := \frac{M_{r.\text{neg}}}{f_{\text{fd.pr.slab}} \left( d_{\text{fl.slab}} - \frac{\beta_{1.\text{super}} \cdot c_{\text{b1.slab}}}{2} \right)} = 1.1 \cdot \text{in}^2 \quad [\text{AASHTO GFRP 2009, 2.9.3.2.2-3}]$$

Area per linear foot required at midspan and support, considering the section under-reinforced ( $\rho_f < \rho_{fb}$ )

$$\text{area}_{\text{provided}} := A_{\text{fl.slab}} = 3.7 \cdot \text{in}^2 \quad \text{area per linear foot provided at midspan and support (symmetric)}$$

$$\text{over\_reinf\_ratio}_{\text{pos.slab}} := \begin{cases} \frac{\text{area}_{\text{required.pos.slab}}}{\text{area}_{\text{provided}}} & \text{if } \frac{\text{area}_{\text{required.pos.slab}}}{\text{area}_{\text{provided}}} \geq 0.6 \\ 0.6 & \text{otherwise} \end{cases} = 0.6$$

$$\text{over\_reinf\_ratio}_{\text{neg.slab}} := \begin{cases} \frac{\text{area}_{\text{required.neg.slab}}}{\text{area}_{\text{provided}}} & \text{if } \frac{\text{area}_{\text{required.neg.slab}}}{\text{area}_{\text{provided}}} \geq 0.6 \\ 0.6 & \text{otherwise} \end{cases} = 0.6$$

$$L_{\text{tension.neg.reduced}} := L_{\text{d.tension.neg.slab}} \cdot \text{over\_reinf\_ratio}_{\text{neg.slab}} = 38.8 \cdot \text{in} \quad [\text{ACI318-14 25.4.10}]$$

$$L_{\text{tension.pos.reduced}} := L_{\text{d.tension.pos.slab}} \cdot \text{over\_reinf\_ratio}_{\text{pos.slab}} = 20.1 \cdot \text{in} \quad [\text{ACI318-14 25.4.10}]$$

Lap splice length  $L_{\text{sp,sl}}$  :

$$L_{\text{sp.neg.slab}} := \max(12 \text{in}, 1.3 \cdot L_{\text{tension.neg.reduced}}) = 50 \cdot \text{in} \quad [\text{AASHTO GFRP 2009, 2.12.4}]$$

$$L_{\text{sp.pos.slab}} := \max(12 \text{in}, 1.3 \cdot L_{\text{tension.pos.reduced}}) = 26 \cdot \text{in} \quad [\text{AASHTO GFRP 2009, 2.12.4}]$$



### C. Shear Verification



The nominal shear resistance provide by concrete,  $V_c$

$$b_{\text{slab}} = 12 \cdot \text{in} \quad \text{unitary width}$$

$$c_{1.\text{slab}} := \frac{a_{\text{fl.slab}}}{\beta_{1.\text{super}}} = 4.8 \cdot \text{in} \quad \text{neutral axis depth at support}$$

$$c_{2.\text{slab}} := \frac{a_{\text{fl.slab}}}{\beta_{1.\text{super}}} = 4.8 \cdot \text{in} \quad \text{neutral axis depth at middle span}$$

$$V_{c1.\text{slab}} := 0.16 \sqrt{f_{c.\text{super}} \cdot \text{ksi}} \cdot b_{\text{slab}} \cdot c_{1.\text{slab}} = 19.6 \cdot \text{kip} \quad [\text{AASHTO GFRP 2009, 2.7.4.2}]$$

$$\text{Resistance factor } \phi_v \text{ for shear is } 0.75 \quad [\text{AASHTO GFRP 2009, 2.7.4.2}]$$

$$\phi_v \cdot V_{c1.\text{slab}} = 14.7 \cdot \text{kip}$$

CheckShear := "VERIFIED, NO STIRRUP REQUIRED" if  $V_{rightB\_d} \leq \phi_v \cdot V_{c1.slab}$   
 "REDESIGN" otherwise

CheckShear = "VERIFIED, NO STIRRUP REQUIRED"



## D. Crack Width Verification

### D1. Data recall (section B of chapter 1.04)



Crack width is checked using Equation 2.9.3.4-1 of AASHTO GFRP 2009. A crack width limit,  $w_{lim}$  of 0.020 in. is used.

$w_{lim} := 0.020\text{in}$	Crack width limit
$diam_{No.pr.slab} = 1.25\text{-in}$	Diameter of deck primary GFRP reinforcement
$area_{No.pr.slab} = 1.23\text{-in}^2$	Area of deck primary GFRP reinforcement
$E_{fNo.pr.slab} = 7142\text{-ksi}$	Modulus of elasticity of deck primary GFRP reinforcement
$f_{fuNo.pr.slab} = 101.3\text{-ksi}$	Tensile strength of deck primary reinforcement for product certification as reported by GFRP manufacturer [AASHTO GFRP 2009, 2.6.1.2]
$f_{fd.pr.slab} = 70.9\text{-ksi}$	Design strength of deck primary reinforcement considering reduction for service environment [AASHTO GFRP 2009, 2.6.1.2-1]
$\epsilon_{fuNo.pr.slab} = 1.5\text{-}\%$	Tensile strain of deck primary reinforcement for product certification as reported by GFRP manufacturer [AASHTO GFRP 2009, 2.6.1.2]
$\epsilon_{fdNo.pr.slab} = 1.1\text{-}\%$	Design strain of deck primary reinforcement reinforcement considering reduction for service environment [AASHTO GFRP 2009, 2.6.1.2]



### D2. Support



Recall crack width limit  $w_{lim} = 0.02\text{-in}$

Ratio of modulus of elasticity of bars to modulus of elasticity of concrete  $n_{f.slab} := \frac{E_{fNo.pr.slab}}{E_{c.super}} = 2.1$

Ratio of depth of neutral axis to reinforcement depth

$$k_{1.slab} := \sqrt{2\rho_{f1.slab} \cdot n_{f.slab} + (\rho_{f1.slab} \cdot n_{f.slab})^2} - \rho_{f1.slab} \cdot n_{f.slab}$$

$$k_{1.slab} = 0.2$$

Tensile stress in GFRP under service loads

$$f_{fs1.slab} := \frac{M_{neg}}{A_{f1.slab} \cdot d_{f1.slab} \cdot \left(1 - \frac{k_{1.slab}}{3}\right)} = 13.8 \cdot \text{ksi}$$

Ratio of distance from neutral axis to extreme tension fiber to distance from neutral axis to center of tensile reinforcement

$$\beta_{11.slab} := \frac{t_{slab} - k_{1.slab} \cdot d_{f1.slab}}{d_{f1.slab} \cdot (1 - k_{1.slab})} = 1.2$$

Thickness of concrete cover measured from extreme tension fiber to center of bar

$$d_{c1.slab} := t_{slab} - d_{f1.slab} = 2.1 \cdot \text{in}$$

Bond factor (provided by the manufacturer)

$$k_b := 0.9$$

The crack width under service loads is: [AASHTO GFRP 2009, 2.9.3.4-1]

$$w_{1.slab} := 2 \cdot \frac{f_{fs1.slab}}{E_{fNo_{pr.slab}}} \cdot \beta_{11.slab} \cdot k_b \cdot \sqrt{d_{c1.slab}^2 + \left(\frac{s_{f\_bar1.slab}}{2}\right)^2} = 0.012 \cdot \text{in}$$

The crack width limit is:

$$w_{lim} = 0.02 \cdot \text{in}$$

$$\text{Check\_SlabCrack1} := \begin{cases} \text{"VERIFIED"} & \text{if } w_{1.slab} \leq w_{lim} \\ \text{"NOT VERIFIED"} & \text{otherwise} \end{cases}$$

Check\_SlabCrack1 = "VERIFIED"

The maximum recommended bar spacing to limit cracking is:

[ACI 440.1R] 9.1.3(a)

$$s_{Ospina\_1.slab} := \min \left( 1.15 \cdot \frac{E_{fNo_{pr.slab}} \cdot w_{lim}}{f_{fs1.slab} \cdot k_b} - 2.5 \cdot c_c, 0.92 \cdot \frac{E_{fNo_{pr.slab}} \cdot w_{lim}}{f_{fs1.slab} \cdot k_b} \right) = 9.4 \cdot \text{in}$$

$$\text{Check\_SpacingOspina1} := \begin{cases} \text{"VERIFIED"} & \text{if } s_{f\_bar1.slab} \leq s_{Ospina\_1.slab} \\ \text{"NOT VERIFIED"} & \text{otherwise} \end{cases}$$

Check\_SpacingOspina1 = "VERIFIED"



### D3. Middle Span



Recall crack width limit

$$w_{lim} = 0.02 \cdot \text{in}$$

Ratio of modulus of elasticity of bars to modulus of elasticity of concrete

$$n_{f.slab} = 2.1$$

Ratio of depth of neutral axis to reinforcement depth

$$k_{2.slab} := k_{1.slab} = 0.2$$

Bar spacing

$$s_{f\_bar2.slab} := s_{f\_bar1.slab} = 4 \cdot \text{in}$$

Tensile stress in GFRP under service loads

$$f_{fs2.slab} := \frac{M_{pos}}{A_{f2.slab} \cdot d_{f2.slab} \cdot \left(1 - \frac{k_{2.slab}}{3}\right)} = 14.4 \cdot \text{ksi}$$

Ratio of distance from neutral axis to extreme tension fiber to distance from neutral axis to center of tensile reinforcement

$$\beta_{12.slab} := \frac{t_{slab} - k_{2.slab} \cdot d_{f2.slab}}{d_{f2.slab} \cdot (1 - k_{2.slab})} = 1.2$$

Thickness of concrete cover measured from extreme tension fiber to center of bar

$$d_{c2.slab} := t_{slab} - d_{f2.slab} = 2.1 \cdot \text{in}$$

Bond factor (provided by the manufacturer)

$$k_b = 0.9$$

The crack width under service loads is:

[AASHTO GFRP 2009, 2.9.3.4-1]

$$w_{2.slab} := 2 \frac{f_{fs2.slab}}{E_{fNo\_pr.slab}} \beta_{11.slab} \cdot k_b \cdot \sqrt{d_{c1.slab}^2 + \left(\frac{s_{f\_bar1.slab}}{2}\right)^2} = 0.013 \cdot \text{in}$$

The crack width limit is:

$$w_{lim} = 0.02 \cdot \text{in}$$

$$\text{Check\_SlabCrack2} := \begin{cases} \text{"VERIFIED"} & \text{if } w_{2.slab} \leq w_{lim} \\ \text{"NOT VERIFIED"} & \text{otherwise} \end{cases}$$

Check\_SlabCrack2 = "VERIFIED"

The maximum recommended bar spacing to limit cracking is:

[ACI 440.1R 9.1.3a]

$$s_{\text{Ospina}_2.\text{slab}} := \min \left( 1.15 \cdot \frac{E_{f\text{No}_{pr.\text{slab}}} \cdot w_{\text{lim}}}{f_{fs2.\text{slab}} \cdot k_b} - 2.5 \cdot c_c, 0.92 \cdot \frac{E_{f\text{No}_{pr.\text{slab}}} \cdot w_{\text{lim}}}{f_{fs2.\text{slab}} \cdot k_b} \right) = 8.9 \text{ in}$$

$$\text{Check\_SlabSpacingOspina2} := \begin{cases} \text{"VERIFIED"} & \text{if } s_{f\_bar2.\text{slab}} \leq s_{\text{Ospina}_2.\text{slab}} \\ \text{"NOT VERIFIED"} & \text{otherwise} \end{cases}$$

Check\_SlabSpacingOspina2 = "VERIFIED"



## E. Fatigue and Creep Rupture

### E1. Data recall (section B of chapter 1.04)



#### GFRP creep rupture limit stress

Creep rupture stress limitation factor

$$k_{\text{creep}_R} := 0.2 \quad [\text{AASHTO GFRP 2009, 2.7.3-1}]$$

$$f_{f\_creep} := k_{\text{creep}_R} \cdot f_{fd.pr.slab} = 14.2 \text{ ksi} \quad \text{Creep and fatigue rupture limit stress}$$

$$\text{diam}_{\text{No}_{pr.slab}} = 1.25 \text{ in} \quad \text{Diameter of deck primary GFRP reinforcement}$$

$$\text{area}_{\text{No}_{pr.slab}} = 1.23 \text{ in}^2 \quad \text{Area of deck primary GFRP reinforcement}$$

$$E_{f\text{No}_{pr.slab}} = 7142 \text{ ksi} \quad \text{Modulus of elasticity of deck primary GFRP reinforcement}$$

$$f_{fu\text{No}_{pr.slab}} = 101.3 \text{ ksi} \quad \text{Tensile strength of deck primary reinforcement for product certification as reported by GFRP manufacturers [AASHTO GFRP 2009, 2.6.1.2]}$$

$$f_{fd.pr.slab} = 70.9 \text{ ksi} \quad \text{Design strength of deck primary reinforcement considering reduction for service environment [AASHTO GFRP 2009, 2.6.1.2-1]}$$

$$\epsilon_{fu\text{No}_{pr.slab}} = 1.5\% \quad \text{Tensile strain of deck primary reinforcement for product certification as reported by GFRP manufacturers [AASHTO GFRP 2009, 2.6.1.2]}$$

$$\epsilon_{fd\text{No}_{pr.slab}} = 1.1\% \quad \text{Design strain of deck primary reinforcement considering reduction for service environment [AASHTO GFRP 2009, 2.6.1.2]}$$



### E2. Support



The stress level in the GFRP reinforcement for checking creep rupture failure is evaluated considering the total unfactored dead loads.

$M_{1\_creep.slab} := M_{fatigue.neg} = 50.7 \cdot \text{ft} \cdot \text{kip}$	Bending moment due to dead load
$f_{f\_creep} = 14.2 \cdot \text{ksi}$	The GFRP creep and fatigue rupture limit stress
$n_{f.slab} = 2.1$	Ratio of modulus of elasticity of bars to modulus of elasticity of concrete
$k_{1.slab} = 0.2$	Ratio of depth of neutral axis to reinforcement depth.
The tensile stress in the GFRP is:	
$f_{f1\_creep.slab} := \frac{M_{1\_creep.slab}}{A_{f1.slab} \cdot d_{f1.slab} \cdot \left(1 - \frac{k_{1.slab}}{3}\right)} = 11.3 \cdot \text{ksi}$	
$\text{Check\_Creep1} := \begin{cases} \text{"VERIFIED"} & \text{if } f_{f1\_creep.slab} \leq f_{f\_creep} \\ \text{"NOT VERIFIED"} & \text{otherwise} \end{cases}$	
<b>Check_Creep1 = "VERIFIED"</b>	
▲	
<b>E3. Middle span</b>	
▼	
$M_{2\_creep.slab} := M_{fatigue.pos} = 46.7 \cdot \text{ft} \cdot \text{kip}$	Bending moment due to dead load
$f_{f\_creep} = 14.2 \cdot \text{ksi}$	The GFRP creep and fatigue rupture limit stress
$n_{f.slab} = 2.1$	Ratio of modulus of elasticity of bars to modulus of elasticity of concrete
$k_{2.slab} = 0.2$	Ratio of depth of neutral axis to reinforcement depth
$f_{f2\_creep.slab} := \frac{M_{2\_creep.slab}}{A_{f2.slab} \cdot d_{f2.slab} \cdot \left(1 - \frac{k_{2.slab}}{3}\right)} = 10.4 \cdot \text{ksi}$	
$\text{Check\_Creep2} := \begin{cases} \text{"VERIFIED"} & \text{if } f_{f2\_creep.slab} \leq f_{f\_creep} \\ \text{"NOT VERIFIED"} & \text{otherwise} \end{cases}$	
<b>Check_Creep2 = "VERIFIED"</b>	
▲	

## F. Secondary Reinforcement

### F1.Data recall (section B of Chapter 1.04)



$\text{diam}_{\text{No}_{\text{sec.slab}}} = 0.75 \cdot \text{in}$	Diameter of deck secondary GFRP reinforcement
$\text{area}_{\text{No}_{\text{sec.slab}}} = 0.44 \cdot \text{in}^2$	Area of deck secondary GFRP reinforcement
$E_{f\text{No}_{\text{sec.slab}}} = 7208 \cdot \text{ksi}$	Modulus of elasticity of deck secondary GFRP reinforcement
$f_{fu\text{No}_{\text{sec.slab}}} = 109.4 \cdot \text{ksi}$	Tensile strength of deck secondary reinforcement for product certification as reported by GFRP manufacturers [AASHTO GFRP 2009, 2.6.1.2]
$f_{fd.\text{sec.slab}} = 76.6 \cdot \text{ksi}$	Design strength of deck secondary reinforcement considering reduction for service environment [AASHTO GFRP 2009, 2.6.1.2-1]
$\epsilon_{fu\text{No}_{\text{sec.slab}}} = 1.6 \cdot \%$	Tensile strain of deck secondary reinforcement for product certification as reported by GFRP manufacturers [AASHTO GFRP 2009, 2.6.1.2]
$\epsilon_{fd\text{No}_{\text{sec.slab}}} = 1.1 \cdot \%$	Design strain of deck secondary reinforcement reinforcement considering reduction for service environment [AASHTO GFRP 2009, 2.6.1.2]



### F2.Distribution reinforcement



Reinforcement shall be placed in the secondary direction at the bottom of the slab as a percentage of the primary reinforcement for positive moment as follows:

[AASHTO GFRP 2009, 2.11.4.2]

For primary reinforcement parallel to traffic:

$$\text{Recall } A_{f2.\text{slab}} = 3.7 \cdot \text{in}^2$$

The required secondary reinforcement  $A_{\text{sec.req}}$

[AASHTO GFRP 2009, 2.11.4.1]

$$A_{\text{sec.req.slab}} := \min \left( 50\%, \frac{100\%}{\sqrt{\frac{L_{\text{span}}}{\text{ft}}}} \right) \cdot A_{f2.\text{slab}} = 0.6 \cdot \text{in}^2$$

The design width in transverse direction is:

$$b_{\text{trans}} := 12 \text{in}$$

The required number of #6 for secondary reinforcement  $N_{\text{sec.req}}$

$$\text{Recall } \text{diam}_{\text{No}_{\text{sec.slab}}} = 0.75 \cdot \text{in} \quad \text{area}_{\text{No}_{\text{sec.slab}}} = 0.44 \cdot \text{in}^2$$

$$N_{\text{sec.req.slab}} := \frac{A_{\text{sec.req.slab}}}{\text{area}_{N_{\text{sec.slab}}}} = 1.4$$

The design number of #6 for secondary reinforcement  $N_{\text{sec.des}}$  is selected to be 1.5

$$N_{\text{sec.des.slab}} := 1.5$$

The required spacing of #6 reinforcement  $S_{\text{sec.req}}$

$$S_{\text{sec.req.slab}} := \frac{b_{\text{trans}}}{N_{\text{sec.req.slab}}} = 8.5 \cdot \text{in}$$

Spacing for  $A_{\text{sec.req}}$  is  $S_{\text{sec.req}}$ , considering the maximum spacing requirement

[AASHTO GFRP 2009, 2.10.2.2.4]

$$S_{\text{sec.max.slab}} := \min(0.5 \cdot t_{\text{slab}}, 24 \text{in}, S_{\text{sec.req.slab}}) = 8.5 \cdot \text{in}$$

Spacing for minimum spacing [AASHTO GFRP 2009, 2.11.3]

$$S_{\text{sec.min.slab}} := \min(1.5 \cdot \text{diam}_{N_{\text{sec.slab}}}, 1.5 \text{in}) = 1.1 \cdot \text{in}$$

Therefore, the spacing for secondary reinforcement ( $S_{\text{sec.slab}}$ ) is 8 in

$$S_{\text{sec.slab}} := \frac{b_{\text{trans}}}{N_{\text{sec.des.slab}}} = 8 \cdot \text{in}$$

$$\text{CheckingSecondarySpacing} := \begin{cases} \text{"VERIFIED"} & \text{if } S_{\text{sec.min.slab}} \leq S_{\text{sec.slab}} \leq S_{\text{sec.max.slab}} \\ \text{"NOT VERIFIED"} & \text{otherwise} \end{cases}$$

$$\text{CheckingSecondarySpacing} = \text{"VERIFIED"}$$

Use 1.5 #6 GFRP in 1 ft-width of transverse direction for secondary reinforcement. The spacing between #6 GFRP rebars is 8" center to center.



## G. Shrinkage and Temperature Reinforcement

### G1.Data recall (section B of chapter 1.04)



$\text{diam}_{N_{\text{sec.slab}}} = 0.75 \cdot \text{in}$  Diameter of deck secondary GFRP reinforcement

$\text{area}_{N_{\text{sec.slab}}} = 0.44 \cdot \text{in}^2$  Area of deck secondary GFRP reinforcement

$E_{fN_{\text{sec.slab}}} = 7208 \cdot \text{ksi}$  Modulus of elasticity of deck secondary GFRP reinforcement

$f_{fuN_{\text{sec.slab}}} = 109.4 \cdot \text{ksi}$  Tensile strength of deck secondary reinforcement for product certification as reported by GFRP manufacturers [AASHTO GFRP 2009, 2.6.1.2]

$f_{fd.\text{sec.slab}} = 76.6 \cdot \text{ksi}$  Design strength of deck secondary reinforcement considering reduction for service environment [AASHTO GFRP 2009, 2.6.1.2-1]



$\epsilon_{fuNo_{sec.slab}} = 1.6\%$  Tensile strain of deck secondary reinforcement for product certification as reported by GFRP manufacturers [AASHTO GFRP 2009, 2.6.1.2]

$\epsilon_{fdNo_{sec.slab}} = 1.1\%$  Design strain of deck secondary reinforcement considering reduction for service environment [AASHTO GFRP 2009, 2.6.1.2]



## G2. Shrinkage and temperature reinforcement



The ratio of GFRP shrinkage and temperature reinforcement area to gross concrete area  $\rho_{f, st}$ :  
[AASHTO GFRP 2009, 2.11.5]

$$\rho_{f, st} := \min \left( \max \left( 0.0014, 0.0018 \cdot \frac{60 \text{ ksi}}{f_{fd, sec. slab}} \cdot \frac{E_s}{E_{fNo_{sec. slab}}} \right), 0.0036 \right) = 0.0036$$

The design width in the transverse direction

$$b_{trans} = 12 \cdot \text{in}$$

$$A_{g, trans} := b_{trans} \cdot t_{slab} = 216 \cdot \text{in}^2$$

GFRP shrinkage and temperature reinforcement area  $A_{st}$

$$A_{st, slab} := \rho_{f, st} \cdot A_{g, trans} = 0.8 \cdot \text{in}^2$$

The number of required reinforcement for shrinkage and temperature  $N_{st, req}$

$$\text{Recall } \text{diam}_{No_{sec. slab}} = 0.8 \cdot \text{in} \quad \text{area}_{No_{sec. slab}} = 0.4 \cdot \text{in}^2$$

$$N_{st, req, slab} := \frac{A_{st, slab}}{\text{area}_{No_{sec. slab}}} = 1.8$$

Therefore, the number of bars for shrinkage and temperature  $N_{st, des}$  is chosen to be 1 per top and bottom layer.

$$N_{st, des, slab} := 2$$

Therefore, spacing  $S_{st, slt}$ .

$$S_{st, prvd, slab} := \frac{b_{trans}}{\frac{N_{st, des, slab}}{2}} = 12 \cdot \text{in}$$

According to Bridge design guide specification for GFRP reinforcement, the max spacing for shrinkage and temperature  $S_{st, max}$

$$S_{st, max, slab} := \min(3 \cdot t_{slab}, 12 \text{ in}) = 12 \cdot \text{in} \quad [\text{AASHTO GFRP 2009, 2.11.5}]$$

$$\text{Check\_ST\_Spacing} := \begin{cases} \text{"VERIFIED"} & \text{if } S_{st, prvd, slab} \leq S_{st, max, slab} \\ \text{"NOT VERIFIED"} & \text{otherwise} \end{cases} \quad [\text{AASHTO GFRP 2009, 2.11.5}]$$

$$\text{Check\_ST\_Spacing} = \text{"VERIFIED"}$$

Temperature and shrinkage requirements can be met with a #6 GFRP bars @ 12" top and bottom. Secondary reinforcement requirements are met with a #6 @ 8" bottom. Thus, the combined configuration is #6 @ 12" top and #6 @ 8" bottom.



## H. Deflection Verification

### Preliminary Calculations



The maximum allowable deflection due to live load including dynamic effect is:

$$\Delta_{\text{lim.slab}} := \frac{L_{\text{span}}}{800} = 0.525 \cdot \text{in} \quad [\text{AASHTO GFRP 2009, 2.7.2}]$$

The gross moment of inertia is:

$$I_{g.\text{slab}} := \frac{b_{\text{slab}} \cdot t_{\text{slab}}^3}{12} = 5832 \cdot \text{in}^4$$

The negative cracking moment is:

$$M_{\text{crNeg.slab}} := \frac{f_{r.\text{super}} \cdot I_{g.\text{slab}}}{t_{\text{slab}} - c_{1.\text{slab}} - c_c} = 20.9 \cdot \text{kip} \cdot \text{ft}$$

The positive cracking moment is:

$$M_{\text{crPos.slab}} := \frac{f_{r.\text{super}} \cdot I_{g.\text{slab}}}{t_{\text{slab}} - c_{2.\text{slab}} - c_c} = 20.9 \cdot \text{kip} \cdot \text{ft}$$



### Cracked Moment of Inertia



The cracked moment of inertia,  $I_{cr}$ , is computed as follows:

[AASHTO GFRP 2009, Equation 2.7.3-3]

- Case 1: Mid-span

$$I_{\text{cr2.slab}} := \frac{b_{\text{slab}} \cdot d_{f2.\text{slab}}^3}{3} k_{2.\text{slab}}^3 + n_{f.\text{slab}} \cdot A_{f2.\text{slab}} \cdot d_{f2.\text{slab}}^2 \cdot (1 - k_{2.\text{slab}})^2 = 1322 \cdot \text{in}^4$$

- Case 2: Internal support

$$I_{\text{cr1.slab}} := \frac{b_{\text{slab}} \cdot d_{f1.\text{slab}}^3}{3} k_{1.\text{slab}}^3 + n_{f.\text{slab}} \cdot A_{f1.\text{slab}} \cdot d_{f1.\text{slab}}^2 \cdot (1 - k_{1.\text{slab}})^2 = 1322 \cdot \text{in}^4$$



### Effective Moment of Inertia



The effective moment of inertia,  $I_e$ , is computed using AASHTO LRFD 2014 Eq.5.7.3.6.2-1.

The maximum positive bending moment for exterior span due to service loads is:

$$M_{\text{pos}} = 64.6 \cdot \text{kip} \cdot \text{ft}$$

The value of  $I_e$  at midspan is:

$$\text{Recall } I_{g,\text{slab}} = 5.8 \times 10^3 \cdot \text{in}^4$$

The effective moment of inertia,  $I_{e2,\text{slab}}$  at where the maximum positive moment due to service load is: [AASHTO LRFD 2014, 5.7.3.6.2-1]

$$I_{e2,\text{slab}} := \min \left[ I_{g,\text{slab}}, \left( \frac{M_{\text{crPos,slab}}}{M_{\text{pos}}} \right)^3 \cdot I_{g,\text{slab}} + \left[ 1 - \left( \frac{M_{\text{crPos,slab}}}{M_{\text{pos}}} \right)^3 \right] I_{\text{cr2,slab}} \right] = 1475 \cdot \text{in}^4$$



### Maximum Deflection



The maximum allowable deflection is:

$$\Delta_{\text{lim,slab}} = 0.525 \cdot \text{in}$$

The thickness of slab satisfies the minimum requirement of AASHTO LRFD 2014 Bridge Design Specification Table 2.5.2.6.3-1. The instantaneous deflection to be used for the calculation of the long-time deflection is based on the magnification factor.

Considering the bridge is continuous and simply supported, the exterior span can be assumed to be at pinned at one end and fixed at other. Therefore, according to deflection formula of uniformly loaded fixed-pinned beam.

Maximum positive moment due to live load for the exterior span:

$$M_{s\text{Pos}} = 39.6 \cdot \text{kip} \cdot \text{ft}$$

The maximum instantaneous deflection under live loads is:

$$\Delta_{\text{SL,slab,ins}} := \frac{8}{185} \cdot \frac{M_{s\text{Pos}} \cdot L_{\text{span}}^2}{E_{c,\text{super}} \cdot I_{e2,\text{slab}}} = 0.7073 \cdot \text{in}$$

The magnification factor for long-term deflection under live loads is taken directly from AASHTO LRFD 2014 Section 5.7.6.3.2-Here the presence of compression reinforcement ( $A'_f = 2/3 A_{f1,\text{slab}}$ ) is considered even if such reinforcement is not taken into account for strength calculation.

[AASHTO LRFD 2014, 5.7.3.6.3.2]

$$\text{factor}_{\text{lt}} := \begin{cases} \max \left( 1.6, 3 - 1.2 \cdot \frac{\frac{2}{3} \cdot A_{f1,\text{slab}}}{A_{f2,\text{slab}}} \right) & \text{if } I_{e2,\text{slab}} < I_{g,\text{slab}} \\ 4 & \text{if } I_{e2,\text{slab}} = I_{g,\text{slab}} \end{cases} = 2.2$$

$$\Delta_{\text{SL,slab,lt}} := \text{factor}_{\text{lt}} \cdot \Delta_{\text{SL,slab,ins}} = 1.556 \cdot \text{in}$$

$\text{Check\_SlabInstantaneousDeflection} := \begin{cases} \text{"VERIFIED"} & \text{if } \Delta_{\text{SL.slab.ins}} \leq \Delta_{\text{lim.slab}} \\ \text{"SERVICEABILITY SUGGESTION IS NOT MET"} & \text{otherwise} \end{cases}$

$\text{Check\_SlabInstantaneousDeflection} = \text{"SERVICEABILITY SUGGESTION IS NOT MET"}$

$\text{Check\_SlabLongTermDeflection} := \begin{cases} \text{"VERIFIED"} & \text{if } \Delta_{\text{SL.slab.lt}} \leq \Delta_{\text{lim.slab}} \\ \text{"SERVICEABILITY SUGGESTION IS NOT MET"} & \text{otherwise} \end{cases}$

$\text{Check\_SlabLongTermDeflection} = \text{"SERVICEABILITY SUGGESTION IS NOT MET"}$

Even though the instantaneous and long-time deflections are higher than the maximum allowable deflection, the design is considered satisfactory as the effect of parapets and edge beam are disregarded. More sophisticated tools could be considered for the computation of deflections.



## I. Summary of Reinforcement Provided and Detailing

### Primary reinforcement



$N_{o.pr.slab} = 10$	Bar number of primary reinforcement (top and bottom)
$N_{f\_bar1.slab} = 3$	Number of bars per ft
$s_{f\_bar1.slab} = 4 \cdot in$	Spacing
$L_{d.neg.min} = 2.2 \text{ ft}$	Development length for negative moment region
$L_{d.pos.sl} = 2 \text{ ft}$	Development length for positive moment region
$L_{sp.neg.sl.slab} = 92 \cdot in$	Splice length for negative moment region
$L_{sp.pos.sl.slab} = 48 \cdot in$	Splice length for positive moment region

Primary Reinforcement-Section View

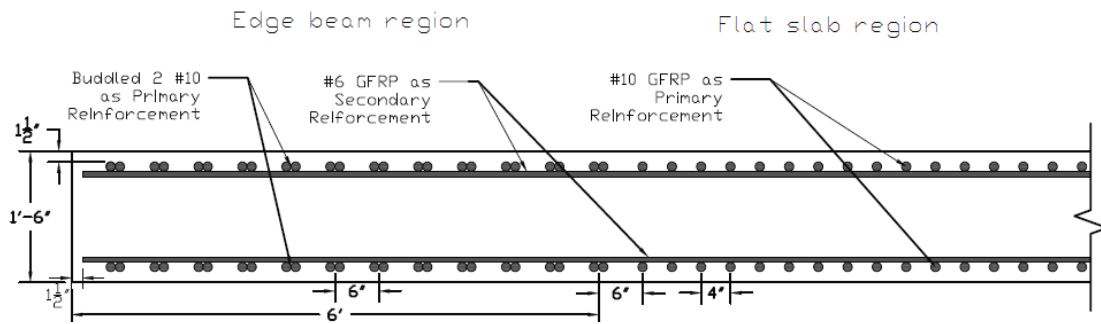

**Secondary reinforcement**



$N_{\text{sec.slab}} = 6$  Bar number of secondary reinforcement (top and bottom)

$S_{\text{sec.sl.tl.slab}} = 8 \cdot \text{in}$  Bar spacing

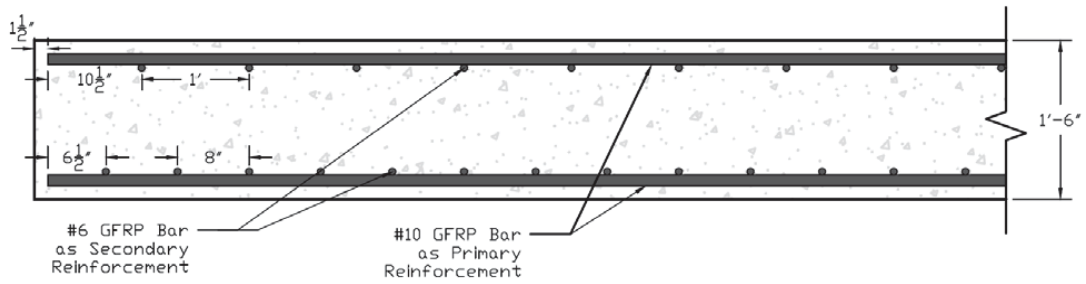



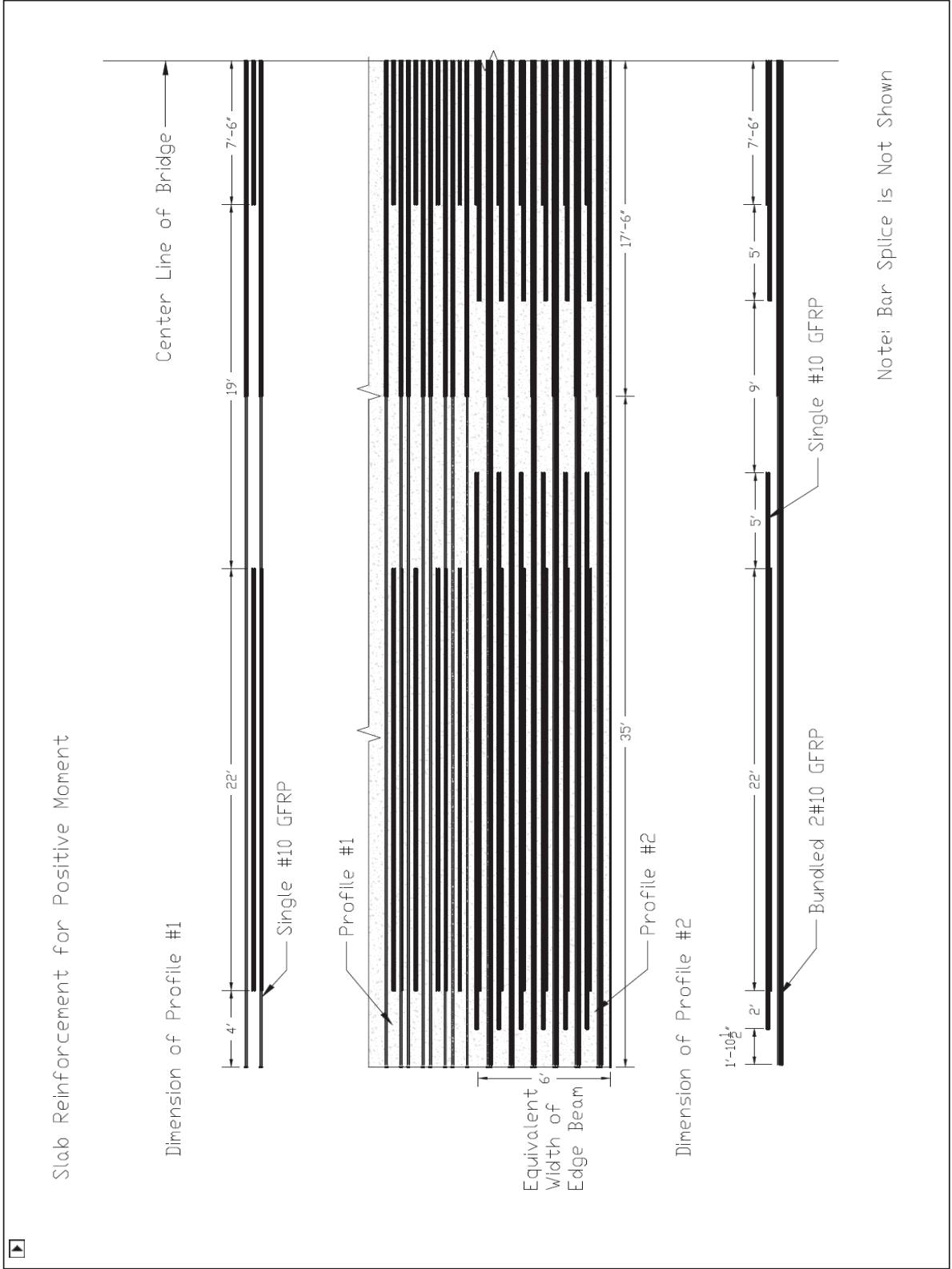







## SUPERSTRUCTURE DESIGN

### Edge Beam Design Loads

---

#### References (links to other Mathcad files)

 Reference:L:\LRFD\_Design\_Example\_#2A thesis\1.03.Design\_Parameters.xmcd(R)

 Reference:L:\LRFD\_Design\_Example\_#2A thesis\2.01.Flat\_Slab\_Design\_Loads.xmcd(R)

#### Description

This section provides the design loads for the flat slab edge beam superstructure.

<b>Page</b>	<b>Contents</b>
57	LRFD Criteria
58	A. Input Variables
59	B. Dead Load Analysis
60	C. Approximate Methods of Analysis - Decks [AASHTO LRFD 2014, 4.6.2]
	C1. Equivalent Strip Widths for Slab-type Bridges [AASHTO LRFD 2014, 4.6.2.3]
	C2. Live Load Analysis
	C3. Limit State Moments and Shears

## LRFD Criteria

**STRENGTH I -** Basic load combination relating to the normal vehicular use of the bridge without wind.

WA = 0 For superstructure design, water load and stream pressure are not applicable.

FR = 0 No friction forces.

$$\text{Strength I} = 1.25 \cdot \text{DC} + 1.50 \cdot \text{DW} + 1.75 \cdot \text{LL} + 0.50 \cdot (\text{TU} + \text{CR} + \text{SH})$$

**STRENGTH II -** Load combination relating to the use of the bridge by Owner-specified special design vehicles, evaluation permit vehicles, or both without wind.

"Permit vehicles are not evaluated in this design example"

**SERVICE I -** Load combination relating to the normal operational use of the bridge with a 55 MPH wind and all loads taken at their nominal values.

BR, WL = 0 For superstructure design, braking forces and wind on live load are not applicable.

CR, SH = 0 Creep and shrinkage is not evaluated in this design example.

$$\text{Service I} = 1.0 \cdot \text{DC} + 1.0 \cdot \text{DW} + 1.0 \cdot \text{LL}$$

**FATIGUE -** Fatigue load combination relating to repetitive gravitational vehicular live load under a single design truck.

$$\text{Fatigue} = 0.75 \cdot \text{LL}$$

**Note:**

- **AASHTO LRFD 2014, C4.6.2.1.6** states that "past practice has been not to check shear in typical decks... It is not the intent to check shear in every deck." In addition, **AASHTO LRFD 2014, 5.14.4.1** states that for cast-in-place slab superstructures designed for moment in conformance with **AASHTO LRFD 2014, 4.6.2.3**, may be considered satisfactory for shear.
- For this design example, shear will not be investigated. From previous past experience, if the slab thickness is chosen according to satisfy LRFD minimum thickness requirements as per the slab to depth ratios and designed utilizing the distribution strips, shear will not control. If special vehicles are used in the design, shear may need to be investigated.

### A. Input Variables

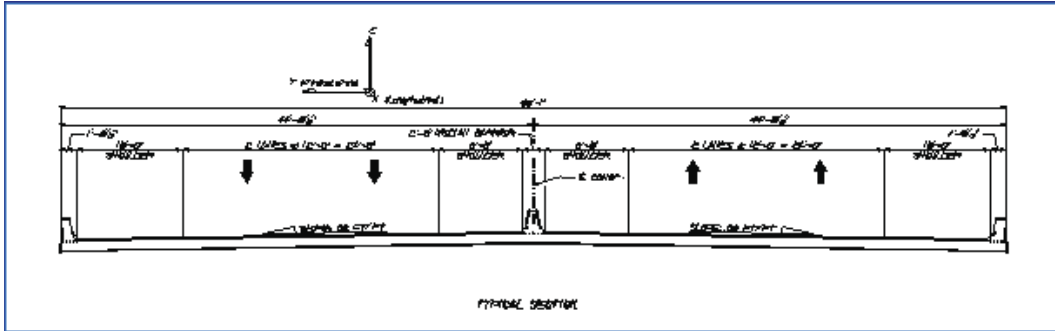

Bridge design span length.....	$L_{span} = 35 \text{ ft}$
Thickness of superstructure slab.....	$t_{eb} := t_{slab} = 18 \cdot \text{in}$
Milling surface thickness.....	$t_{mill} = 0 \cdot \text{in}$
Dynamic Load Allowance.....	$IM = 1.33$
Bridge skew.....	$Skew = -30 \cdot \text{deg}$
Slab width used for computation.....	$b_{eb} := 12 \cdot \text{in}$

## B. Dead Load Analysis

For the dead load calculation, the influence line coordinates for a uniform load applied on the structure is utilized. The influence coordinates are based on AISC's Moments, Shears and Reactions for Continuous Highway Bridges, published 1966.

Unfactored Dead Loads			
Pt.	(10th points) "X" distance	Moments	
		DC	DW
0	0	0.0	0.0
1	3.5	10.3	0.6
2	7	17.6	1.1
3	10.5	22.0	1.4
4	14	23.5	1.5
5	17.5	22.0	1.4
6	21	17.6	1.1
7	24.5	10.3	0.6
8	28	0.0	0.0
9	31.5	-13.2	-0.8
10	35	-29.4	-1.8
11	38.5	-16.2	-1.0
12	42	-5.9	-0.4
13	45.5	1.5	0.1
14	49	5.9	0.4
15	52.5	7.3	0.5
16	56	5.9	0.4
17	59.5	1.5	0.1
18	63	-5.9	-0.4
19	66.5	-16.2	-1.0
20	70	-29.4	-1.8
21	73.5	-13.2	-0.8
22	77	0.0	0.0
23	80.5	10.3	0.6
24	84	17.6	1.1
25	87.5	22.0	1.4
26	91	23.5	1.5
27	94.5	22.0	1.4
28	98	17.6	1.1
29	101.5	10.3	0.6
30	105	0.0	0.0

*(Note: For input values, see Section 2.01 - Design Loads)*

**C. Approximate Methods of Analysis - Decks [AASHTO LRFD 2014, 4.6.2]**

**C1. Equivalent Strip Widths for Slab-type Bridges [AASHTO LRFD 2014, 4.6.2.3]**

The superstructure is designed on a per foot basis longitudinally. However, in order to distribute the live loads, equivalent strips of flat slab deck widths are calculated. The moment and shear effects of a single HL-93 vehicle or multiple vehicles are divided by the appropriate equivalent strip width. The equivalent strips account for the transverse distribution of LRFD wheel loads. This section is only applicable for spans greater than **15 feet**.

**One design lane**

The equivalent width of longitudinal strips per lane for both shear and moment with one lane loaded for the edge beam is given as:

$$E_{\text{onelane,edge}} = \frac{E_{\text{onelane}}}{2} + b_{\text{barrier}} + 12 \cdot \text{in} \leq E_{\text{onelane}} \leq 72 \cdot \text{in}$$

where

$E_{\text{onelane}} = 172 \cdot \text{in}$       The equivalent distribution width for one lane loaded

$b_{\text{barrier}} := 1.5417 \cdot \text{ft}$       Edge of deck to inside face of barrier

The equivalent distribution width for the edge beam is given as.....

$$E_{\text{EdgeBm}} := \frac{E_{\text{onelane}}}{2} + b_{\text{barrier}} + 12 \cdot \text{in}$$

$E_{\text{EdgeBm}} = 116.5 \cdot \text{in}$

Applying the restraint conditions, the equivalent distribution width is given as

$$E_{\text{onelane,edge}} := \text{minval}(E_{\text{EdgeBm}}, E_{\text{onelane}}, 72 \cdot \text{in})$$

$E_{\text{onelane,edge}} = 72 \cdot \text{in}$

or  $E_{\text{onelane,edge}} = 6 \cdot \text{ft}$

**Skew modification**

For skewed bridges, the longitudinal force effects (moments only) **may** be reduced by a factor  $r$ .....

$$r := \text{min}(1.05 - 0.25 \cdot \tan(|\text{Skew}|), 1.00)$$

$r = 0.91$

*(Note: For this design example, the skew modification will not be applied in order to design for more conservative moment values)*

## C2. Live Load Analysis

Determine the live load moments and shears due to one HL-93 vehicle on the continuous flat slab structure. The design live loads will consist of the HL-93 vehicle moments, divided by the appropriate equivalent strip widths. This will result in a design live load per foot width of flat slab.

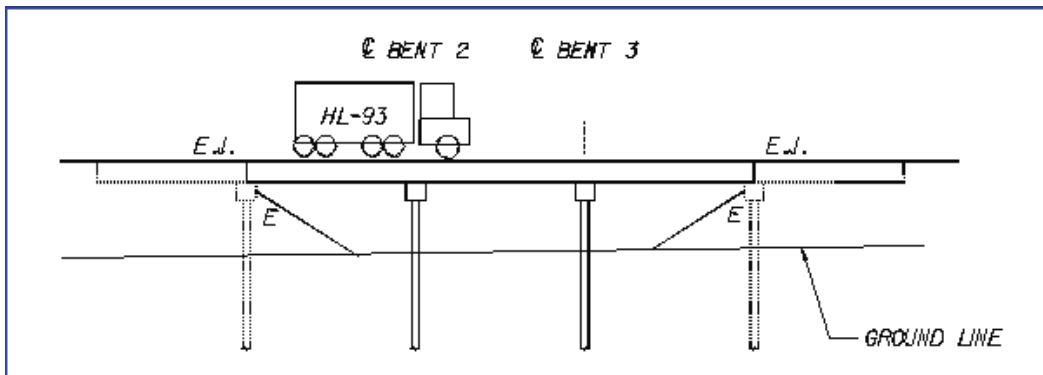

In order to calculate the live load moments and shears, the FDOT MathCad program "LRFD Live Load Generator, English, v2.1".

**Read Live Load results from files generated by FDOT Program**

*(Note: For input values, see Section 2.01 - Design Loads)*

<b>HL-93 Live Load Envelopes</b>										
Pt.	(10th points) "X" distance	Service I		Strength I		Fatigue			Unfactored Lane Load	
		+M	-M	+M	-M	+M	-M	Range	+M	-M
0	0	0.0	0.0	0.0	0.0	0.0	0.0	0.0	0.0	0.0
1	3.5	220.9	-23.0	386.6	-40.2	92.7	-5.8	98.5	31.4	-3.9
2	7	369.4	-46.0	646.5	-80.4	156.0	-11.6	167.5	54.7	-7.8
3	10.5	460.8	-69.0	806.4	-120.7	195.5	-17.3	212.8	70.7	-11.8
4	14	495.0	-92.1	866.3	-161.1	209.2	-23.1	232.3	78.2	-15.7
5	17.5	482.8	-115.0	844.9	-201.3	198.4	-28.9	227.3	78.2	-19.6
6	21	433.1	-137.7	757.9	-241.0	171.1	-34.7	205.8	70.7	-23.5
7	24.5	340.6	-161.5	596.1	-282.6	138.0	-40.5	178.5	54.7	-27.4
8	28	213.3	-184.5	373.3	-322.9	94.9	-59.1	154.0	31.5	-31.5
9	31.5	88.1	-232.9	154.2	-407.6	39.8	-117.9	157.7	15.9	-51.1
10	35	76.1	-383.5	133.2	-671.1	27.0	-186.9	213.8	13.1	-92.0
11	38.5	89.5	-275.7	156.7	-482.5	48.7	-122.2	170.8	11.8	-55.1
12	42	215.3	-228.7	376.8	-400.2	95.6	-81.2	176.8	23.5	-39.2
13	45.5	322.4	-196.6	564.2	-344.1	124.3	-67.5	191.8	43.1	-39.2
14	49	386.1	-165.5	675.7	-289.6	136.6	-54.0	190.5	54.7	-39.2
15	52.5	403.4	-133.9	706.0	-234.3	134.4	-40.5	174.9	58.7	-39.2
16	56	386.1	-165.5	675.7	-289.6	136.6	-54.0	190.5	54.7	-39.2
17	59.5	322.4	-196.6	564.2	-344.1	124.3	-67.5	191.8	43.1	-39.2
18	63	215.3	-228.7	376.8	-400.2	95.6	-81.2	176.8	23.5	-39.2
19	66.5	90.1	-275.7	157.6	-482.5	48.7	-122.2	170.8	11.8	-55.1
20	70	76.1	-383.0	133.2	-670.3	27.0	-186.9	213.8	13.1	-91.6
21	73.5	87.5	-232.9	153.1	-407.6	39.8	-117.9	157.7	15.9	-51.1
22	77	213.3	-184.5	373.3	-322.9	94.9	-59.1	154.0	31.5	-31.5
23	80.5	340.6	-161.5	596.1	-282.6	138.0	-40.5	178.5	54.7	-27.4
24	84	433.1	-137.7	757.9	-241.0	171.1	-34.7	205.8	70.7	-23.5
25	87.5	482.8	-115.0	844.9	-201.3	198.4	-28.9	227.3	78.2	-19.6
26	91	495.0	-92.1	866.3	-161.1	209.2	-23.1	232.3	78.2	-15.7
27	94.5	460.8	-69.0	806.4	-120.7	195.5	-17.3	212.8	70.7	-11.8
28	98	369.4	-46.0	646.5	-80.4	156.0	-11.6	167.5	54.7	-7.8
29	101.5	220.9	-23.0	386.6	-40.2	92.7	-5.8	98.5	31.4	-3.9
30	105	0.0	0.0	0.0	0.0	0.0	0.0	0.0	0.0	0.0

As per **AASHTO LRFD 2014 4.6.2.1.4a**, the edge beams shall be assumed to support one line of wheels and a tributary portion of the design lane load.

The HL-93 live load moment envelopes shown in the above summary include lane loads (except for Fatigue). The lane load and truck moments need to be separated and manipulated separately. Since the unfactored lane load envelopes are given, the separated values for truck and lane can be calculated and multiplied by the appropriate factors.

Edge beams shall be assumed to support one line of wheels, therefore multiply the truck moments by

$$\text{Factor}_{\text{truck}} := 0.5$$

Tributary portion of the design lane load is given by,  $\text{Factor}_{\text{lane}}$ , since the maximum width of the edge beam is limited by the LRFD to 72 inches.

$$\text{Factor}_{\text{lane}} := \frac{E_{\text{onelane,edge}} - b_{\text{barrier}}}{10\text{-ft}} \qquad \text{Factor}_{\text{lane}} = 0.446$$

HL-93 Live Load Envelopes												
		Service I				Strength I				Fatigue		
(10th points)		Truck		Lane		Truck		Lane				
Pts.	distance	+M	-M	+M	-M	+M	-M	+M	-M	+M	-M	M <sub>Range</sub>
0	0	0.0	0.0	0.0	0.0	0.0	0.0	0.0	0.0	0.0	0.0	0.0
1	3.5	94.8	-9.5	14.0	-1.7	165.8	-16.7	24.5	-3.1	92.7	-5.8	98.5
2	7	157.4	-19.1	24.4	-3.5	275.4	-33.4	42.7	-6.1	156.0	-11.6	167.5
3	10.5	195.1	-28.6	31.5	-5.3	341.4	-50.0	55.1	-9.2	195.5	-17.3	212.8
4	14	208.4	-38.2	34.9	-7.0	364.7	-66.8	61.0	-12.2	209.2	-23.1	232.3
5	17.5	202.3	-47.7	34.9	-8.7	354.0	-83.5	61.0	-15.3	198.4	-28.9	227.3
6	21	181.2	-57.1	31.5	-10.5	317.1	-99.9	55.1	-18.3	171.1	-34.7	205.8
7	24.5	143.0	-67.0	24.4	-12.2	250.2	-117.3	42.7	-21.4	138.0	-40.5	178.5
8	28	90.9	-76.5	14.0	-14.0	159.1	-133.9	24.6	-24.6	94.9	-59.1	154.0
9	31.5	36.1	-90.9	7.1	-22.8	63.2	-159.1	12.4	-39.9	39.8	-117.9	157.7
10	35	31.5	-145.8	5.8	-41.0	55.2	-255.1	10.2	-71.8	27.0	-186.9	213.8
11	38.5	38.9	-110.3	5.3	-24.6	68.0	-193.0	9.2	-43.0	48.7	-122.2	170.8
12	42	95.9	-94.8	10.5	-17.5	167.8	-165.8	18.3	-30.6	95.6	-81.2	176.8
13	45.5	139.6	-78.7	19.2	-17.5	244.4	-137.7	33.6	-30.6	124.3	-67.5	191.8
14	49	165.7	-63.2	24.4	-17.5	290.0	-110.5	42.7	-30.6	136.6	-54.0	190.5
15	52.5	172.4	-47.4	26.2	-17.5	301.6	-82.9	45.8	-30.6	134.4	-40.5	174.9
16	56	165.7	-63.2	24.4	-17.5	290.0	-110.5	42.7	-30.6	136.6	-54.0	190.5
17	59.5	139.6	-78.7	19.2	-17.5	244.4	-137.7	33.6	-30.6	124.3	-67.5	191.8
18	63	95.9	-94.8	10.5	-17.5	167.8	-165.8	18.3	-30.6	95.6	-81.2	176.8
19	66.5	39.1	-110.3	5.3	-24.6	68.5	-193.0	9.2	-43.0	48.7	-122.2	170.8
20	70	31.5	-145.7	5.8	-40.8	55.2	-255.0	10.2	-71.4	27.0	-186.9	213.8
21	73.5	35.8	-90.9	7.1	-22.8	62.6	-159.1	12.4	-39.9	39.8	-117.9	157.7
22	77	90.9	-76.5	14.0	-14.0	159.1	-133.9	24.6	-24.6	94.9	-59.1	154.0
23	80.5	143.0	-67.0	24.4	-12.2	250.2	-117.3	42.7	-21.4	138.0	-40.5	178.5
24	84	181.2	-57.1	31.5	-10.5	317.1	-99.9	55.1	-18.3	171.1	-34.7	205.8
25	87.5	202.3	-47.7	34.9	-8.7	354.0	-83.5	61.0	-15.3	198.4	-28.9	227.3
26	91	208.4	-38.2	34.9	-7.0	364.7	-66.8	61.0	-12.2	209.2	-23.1	232.3
27	94.5	195.1	-28.6	31.5	-5.3	341.4	-50.0	55.1	-9.2	195.5	-17.3	212.8
28	98	157.4	-19.1	24.4	-3.5	275.4	-33.4	42.7	-6.1	156.0	-11.6	167.5
29	101.5	94.8	-9.5	14.0	-1.7	165.8	-16.7	24.5	-3.1	92.7	-5.8	98.5
30	105	0.0	0.0	0.0	0.0	0.0	0.0	0.0	0.0	0.0	0.0	0.0



Combine the truck and lane loads per each limit state and divide the moments by the distribution width,  $E_{onelane.edge} = 6 \cdot ft$  to obtain the design values for live load.

Design Live Load Envelopes						E= 6.0 ft		
Joint	(10th points) "X" distance	Service I		Strength I		Fatigue		
		+M	-M	+M	-M	+M	-M	M <sub>Range</sub>
0	0	0.0	0.0	0.0	0.0	0.0	0.0	0.0
1	3.5	15.8	-1.9	27.6	-3.1	15.5	-1.0	16.4
2	7	26.2	-3.8	45.9	-6.1	26.0	-1.9	27.9
3	10.5	32.5	-5.6	56.9	-9.2	32.6	-2.9	35.5
4	14	34.7	-7.5	60.8	-12.3	34.9	-3.9	38.7
5	17.5	33.7	-9.4	59.0	-15.4	33.1	-4.8	37.9
6	21	30.2	-11.3	52.9	-18.4	28.5	-5.8	34.3
7	24.5	23.8	-13.2	41.7	-21.6	23.0	-6.7	29.8
8	28	15.1	-15.1	26.5	-24.7	15.8	-9.8	25.7
9	31.5	6.0	-18.9	10.5	-30.3	6.6	-19.7	26.3
10	35	5.3	-31.1	9.2	-49.3	4.5	-31.2	35.6
11	38.5	6.5	-22.5	11.3	-36.3	8.1	-20.4	28.5
12	42	16.0	-18.7	28.0	-30.5	15.9	-13.5	29.5
13	45.5	23.3	-16.0	40.7	-25.9	20.7	-11.2	32.0
14	49	27.6	-13.4	48.3	-21.3	22.8	-9.0	31.8
15	52.5	28.7	-10.8	50.3	-16.7	22.4	-6.7	29.2
16	56	27.6	-13.4	48.3	-21.3	22.8	-9.0	31.8
17	59.5	23.3	-16.0	40.7	-25.9	20.7	-11.2	32.0
18	63	16.0	-18.7	28.0	-30.5	15.9	-13.5	29.5
19	66.5	6.5	-22.5	11.4	-36.3	8.1	-20.4	28.5
20	70	5.3	-31.1	9.2	-49.3	4.5	-31.2	35.6
21	73.5	6.0	-18.9	10.4	-30.3	6.6	-19.7	26.3
22	77	15.1	-15.1	26.5	-24.7	15.8	-9.8	25.7
23	80.5	23.8	-13.2	41.7	-21.6	23.0	-6.7	29.8
24	84	30.2	-11.3	52.9	-18.4	28.5	-5.8	34.3
25	87.5	33.7	-9.4	59.0	-15.4	33.1	-4.8	37.9
26	91	34.7	-7.5	60.8	-12.3	34.9	-3.9	38.7
27	94.5	32.5	-5.6	56.9	-9.2	32.6	-2.9	35.5
28	98	26.2	-3.8	45.9	-6.1	26.0	-1.9	27.9
29	101.5	15.8	-1.9	27.6	-3.1	15.5	-1.0	16.4
30	105	0.0	0.0	0.0	0.0	0.0	0.0	0.0

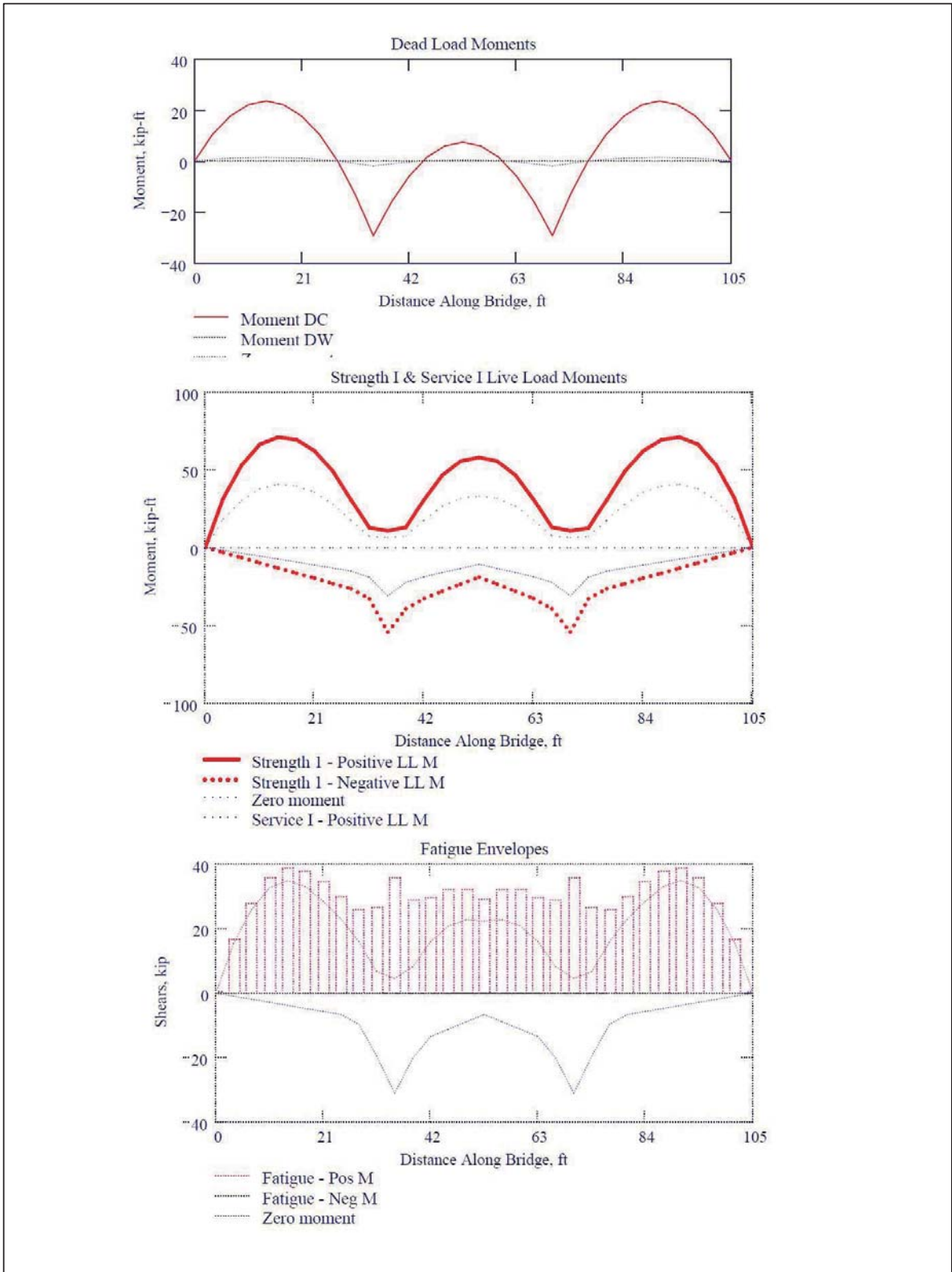

**C3. Limit State Moments and Shears**

The service and strength limit states used to design the section are calculated as follows:

Limit State Design Loads									
Pt.	"X" dist	Service I 1.0DC + 1.0DW + 1.0LL		Strength I 1.25DC + 1.50DW + 1.75LL		Fatigue 1.0DC + 1.0DW + 1.5LL M <sub>Range</sub> = 0.75LL ; -M <sub>min</sub> = 0.75LL			
		+M	-M	+M	-M	+M	-M	M <sub>Range</sub>	-M <sub>min</sub>
0	0	0.0	0.0	0.0	0.0	0.0	0.0	0.0	0.0
1	3.5	26.7	9.0	41.5	10.5	34.1	9.5	12.3	-0.7
2	7	45.0	15.0	69.6	17.1	57.7	15.8	20.9	-1.4
3	10.5	55.9	17.8	86.5	19.7	72.3	19.1	26.6	-2.2
4	14	59.7	17.4	92.4	18.4	77.3	19.2	29.0	-2.9
5	17.5	57.1	14.0	88.6	13.1	73.0	16.2	28.4	-3.6
6	21	48.9	7.5	76.5	4.0	61.5	10.0	25.7	-4.3
7	24.5	34.8	-2.3	55.5	-9.3	45.4	0.8	22.3	-5.1
8	28	15.1	-15.1	26.5	-26.4	23.7	-14.8	19.3	-7.4
9	31.5	-8.0	-33.0	-7.2	-50.9	-4.1	-43.5	19.7	-14.7
10	35	-26.0	-62.3	-30.3	-94.0	-24.5	-77.9	26.7	-23.4
11	38.5	-10.7	-39.6	-10.4	-61.0	-5.0	-47.7	21.4	-15.3
12	42	9.7	-24.9	20.1	-40.6	17.7	-26.5	22.1	-10.2
13	45.5	24.8	-14.5	42.7	-26.1	32.6	-15.3	24.0	-8.4
14	49	33.9	-7.2	56.2	-15.6	40.4	-7.3	23.8	-6.7
15	52.5	36.5	-3.0	60.1	-9.0	41.4	-2.3	21.9	-5.1
16	56	33.9	-7.2	56.2	-15.6	40.4	-7.3	23.8	-6.7
17	59.5	24.8	-14.5	42.7	-26.1	32.6	-15.3	24.0	-8.4
18	63	9.7	-24.9	20.1	-40.6	17.7	-26.5	22.1	-10.2
19	66.5	-10.6	-39.6	-10.3	-61.0	-5.0	-47.7	21.4	-15.3
20	70	-26.0	-62.3	-30.3	-93.9	-24.5	-77.9	26.7	-23.4
21	73.5	-8.1	-33.0	-7.3	-50.9	-4.1	-43.5	19.7	-14.7
22	77	15.1	-15.1	26.5	-26.4	23.7	-14.8	19.3	-7.4
23	80.5	34.8	-2.3	55.5	-9.3	45.4	0.8	22.3	-5.1
24	84	48.9	7.5	76.5	4.0	61.5	10.0	25.7	-4.3
25	87.5	57.1	14.0	88.6	13.1	73.0	16.2	28.4	-3.6
26	91	59.7	17.4	92.4	18.4	77.3	19.2	29.0	-2.9
27	94.5	55.9	17.8	86.5	19.7	72.3	19.1	26.6	-2.2
28	98	45.0	15.0	69.6	17.1	57.7	15.8	20.9	-1.4
29	101.5	26.7	9.0	41.5	10.5	34.1	9.5	12.3	-0.7
30	105	0.0	0.0	0.0	0.0	0.0	0.0	0.0	0.0

<-Maximum positive moment and corresponding fatigue values

<-Maximum negative moment and corresponding fatigue values

Maximum negative Moments =	-62.3	-94.0	77.3	29.0	-2.9
Maximum positive Moments =	59.7	92.4	-77.9	26.7	-23.4





▢ Defined Units



## SUPERSTRUCTURE DESIGN

### GFRP-Reinforced Edge Beam Design

#### References (links to other mathcad files)

-  Reference:L:\LRFD\_Design\_Example\_#2A thesis\1.03.Design\_Parameters.xmcd(R)
-  Reference:L:\LRFD\_Design\_Example\_#2A thesis\1.04.Material\_Properties.xmcd(R)
-  Reference:L:\LRFD\_Design\_Example\_#2A thesis\2.01.Flat\_Slab\_Design\_Loads.xmcd(R)
-  Reference:L:\LRFD\_Design\_Example\_#2A thesis\2.02.GFRP\_Flat\_Slab\_Design.xmcd(R)
-  Reference:L:\LRFD\_Design\_Example\_#2A thesis\2.03.Edge\_Beam\_Design\_Loads.xmcd(R)

**Description** This section provides the design for the GFRP-reinforced Edge Beam superstructure.

<b>Page</b>	<b>Contents</b>
68	A. Input Variables
69	B. Design of Primary Reinforcement
	B1. Data Recall
	B2. Select Primary Reinforcement and Limits
	B3. Negative Moment Region - Flexural Strength at Support
	B4. Development Length at Support
	B5. Positive Moment Region - Flexural Strength at Middle Span
	B6. Development Length at Middle Span
	B7. Reinforcement Splices
77	C. Shear Verification
78	D. Crack Width Verification
	D1. Data Recall
	D2. Support
	D3. Middle Span
81	E. Fatigue and Creep Rupture
	E1. Data Recall
	E2. Support
	E2. Middle Span
82	F. Secondary Reinforcement
	F1.Data Recall
	F2.Reinforcement Distribution
84	G. Shrinkage and Temperature Reinforcement
	G1.Data Recall
	G2.Shrinkage and Temperature Reinforcement
85	H. Deflection Verification
87	I. Summary of Provided Reinforcement and Detailing

### A. Input Variables



Maximum positive moments and corresponding fatigue values

Service	$M_{pos.eb} := 65.5\text{ft}\cdot\text{kip}$
Strength	$M_{r.pos.eb} := 102.5\text{ft}\cdot\text{kip}$
Fatigue	$M_{fatigue.pos.eb} := 77.3\text{ft}\cdot\text{kip}$
	$M_{rang.pos.eb} := 29\text{ft}\cdot\text{kip}$
	$M_{min.pos.eb} := -2.9\text{ft}\cdot\text{kip}$
Live Load	$M_{sPos.eb} := 40.5\text{ft}\cdot\text{kip}$

Maximum negative moment and corresponding fatigue values

Service	$M_{neg.eb} := 62.3\text{ft}\cdot\text{kip}$
Strength	$M_{r.neg.eb} := 94\text{ft}\cdot\text{kip}$
Fatigue	$M_{fatigue.neg.eb} := 77.9\text{ft}\cdot\text{kip}$
	$M_{rang.neg.eb} := -26.7\text{ft}\cdot\text{kip}$
	$M_{min.neg.eb} := 23.4\text{ft}\cdot\text{kip}$
Live Load	$M_{sNeg.eb} := 31.1\text{ft}\cdot\text{kip}$



Load condition

DC represents the dead load of components & attachment, and DW represents dead load of wearing surface.

$DC = 0.2\cdot\text{klf}$

$DW = 0.02\cdot\text{klf}$

For negative moment between points of contraflexure under a uniform load on all spans, and reaction at interior piers only, 90 percent of the effect of two design trucks spaced a minimum of 50.0 ft between the lead axle of one truck and the rear axle of the other truck, combined with 90 percent of the effect of the design lane load. The distance between the 32.0-kip axles of each truck shall be taken as 14.0 ft. The two design trucks shall be placed in adjacent spans to produce maximum force effects. Edge beam is assumed to support one line of wheels.

Lane Load  $LL_{lane} \quad LL_{lane} \quad [AASHTO LRFD 2014, 3.6.1.2.4]$

Truck Load  $LL_{truck-axis@i}$ , i can be 1, 2 and 3

$LL_{TruckAxisAt1} = 8\cdot\text{kip} \quad [AASHTO LRFD 2014, 3.6.1.2.2]$

$LL_{TruckAxisAt2} = 32\cdot\text{kip}$

$LL_{TruckAxisAt3} = 32\cdot\text{kip}$

Note: The distance between truck axis 1 and 2 is 14 ft and the distance between axis 2 and 3 ranges from 14 ft to 30 ft. However, AASHTO LRFD Bridge Design Specification 3.6.1.3.1 states the distance between the 32.0-kip axles of one truck shall be taken as 14.0 ft in order to obtain the maximum load effect.

$$d_{\text{axisbtw1and2}} = 14 \cdot \text{ft} \quad \text{Distance between axis 1 and 2} \quad [\text{AASHTO LRFD 2014, 3.6.1.3.1}]$$

$$d_{\text{axisbtw2and3}} = 14 \cdot \text{ft} \quad \text{Distance between axis 2 and 3}$$

Based on influence line analysis of 3 span continuous beam, the maximum shear will possibly occur at right side of support B or at left side of support B based on Table 3.0A in AISC Moments Shears and Reactions for Continuous Highway Bridge provided by AISC considering equivalent width for edge beam is 6 ft

$$V_{\text{rightB.eb}} := 18.1 \cdot \text{kip}$$

$$V_{\text{leftB.eb}} := -7.3 \cdot \text{kip}$$

$$V_{\text{rightC.eb}} := -12.1 \cdot \text{kip}$$

$$V_{\text{max.eb}} := \max(|V_{\text{rightB.eb}}|, |V_{\text{leftB.eb}}|, |V_{\text{rightC.eb}}|) = 18.1 \cdot \text{kip}$$

Therefore, the ultimate shear in  $d_n = 15.875 \text{ in}$  from right of support B  $V_{\text{rightB}_d}$

$$V_{\text{rightB}_d \text{ .eb}} := \frac{\left(L_{\text{span}} - 15.88 \text{ in} - \frac{42 \text{ in}}{2}\right) \cdot (V_{\text{rightB.eb}} + |V_{\text{rightC.eb}}|)}{L_{\text{span}}} - |V_{\text{rightC.eb}}| = 15.4 \cdot \text{kip}$$



## B. Design of Primary Reinforcement

### B1. Data recall (section B of chapter 1.04)



$$\text{diam}_{\text{No.pr.slab}} = 1.25 \cdot \text{in} \quad \text{Diameter of deck primary GFRP reinforcement}$$

$$\text{area}_{\text{No.pr.slab}} = 1.23 \cdot \text{in}^2 \quad \text{Area of deck primary GFRP reinforcement}$$

$$E_{f\text{No.pr.slab}} = 7142 \cdot \text{ksi} \quad \text{Modulus of elasticity of deck primary GFRP reinforcement}$$

$$f_{fu\text{No.pr.slab}} = 101.3 \cdot \text{ksi} \quad \text{Tensile strength of deck primary reinforcement for product certification as reported by GFRP manufacturer [AASHTO GFRP 2009, 2.6.1.2]}$$

$$f_{fd.\text{pr.slab}} = 70.9 \cdot \text{ksi} \quad \text{Design strength of deck primary reinforcement considering reduction for service environment [AASHTO GFRP 2009, 2.6.1.2-1]}$$

$$\epsilon_{fu\text{No.pr.slab}} = 1.5\% \quad \text{Tensile strain of deck primary reinforcement for product certification as reported by GFRP manufacturer [AASHTO GFRP 2009, 2.6.1.2]}$$

$$\epsilon_{fd\text{No.pr.slab}} = 1.1\% \quad \text{Design strain of deck primary reinforcement reinforcement considering reduction for service environment [AASHTO GFRP 2009, 2.6.1.2]}$$



### B2. Select primary reinforcement and limits



#### Preliminary GFRP reinforcement

The failure mode depends on the amount of FRP reinforcement. If  $\rho_f$  is larger than the balanced reinforcement ratio,  $\rho_{fb}$ , then concrete crushing is the failure mode. If  $\rho_f$  is smaller than the balanced reinforcement ratio,  $\rho_{fb}$ , then FRP rupture is the failure mode.

$$\rho_{fb1.eb} := 0.85\beta_{1.super} \cdot \frac{f_{c.super} \cdot E_{fNo_{pr.slab}} \cdot \epsilon_{cu}}{f_{fd.pr.slab} \cdot E_{fNo_{pr.slab}} \cdot \epsilon_{cu} + f_{fd.pr.slab}} = 0.01032$$

The effective reinforcement depth

$$d_{fl\_des.eb} := t_{eb} - c_c - \frac{\text{diam}_{No_{pr.slab}}}{2} = 15.88 \cdot \text{in}$$

This reinforcement ratio corresponds to an area of:

$$A_{f\_req1.eb} := \rho_{fb1.eb} \cdot b_{eb} \cdot d_{fl\_des.eb} = 1.97 \cdot \text{in}^2 \quad \text{per foot width}$$

The required number of bars is:

$$N_{f\_req1.eb} := \frac{A_{f\_req1.eb}}{\text{area}_{No_{pr.slab}}} = 1.6$$

The corresponding required spacing is:

$$s_{f\_req1.eb} := \frac{b_{eb} - N_{f\_req1.eb} \cdot \text{diam}_{No_{pr.slab}}}{N_{f\_req1.eb}} = 6.2 \cdot \text{in}$$

The trial number of GFRP bars is:

$$N_{f\_des1.eb} := 4$$

In this case, use bundled two GFRP bars in order to satisfy the later spacing check and shear check. The diameter of the equivalent bundled bars in the width direction is considered as follows:

The equivalent diameter of bundled GFRP

$$\phi_{f.bndl.eb} := 2 \cdot \sqrt{2 \cdot \frac{\text{area}_{No_{pr.slab}}}{\pi}} = 1.8 \cdot \text{in}$$

The number of bundled two GFRP bars:

$$N_{f\_bar1.eb} := \frac{N_{f\_des1.eb}}{2} = 2$$

Therefore, the following bar spacing is selected:

$$s_{f\_bar1.eb} := \frac{b_{eb}}{N_{f\_bar1.eb}} = 6 \cdot \text{in}$$

$$d_{fl.eb} := t_{eb} - c_c - \frac{\phi_{f.bndl.eb}}{2} = 15.6 \cdot \text{in}$$

The minimum required clear bar spacing is:

$$s_{f\_min1.eb} := \max(1.5 \cdot \text{in}, 1.5 \phi_{f.bndl.eb}) = 2.7 \cdot \text{in}$$

The bar clear spacing is:  $s_{f\_bar1.eb} - \text{diam}_{No_{pr.slab}} = 4.8 \cdot \text{in}$

$$\text{Check\_EdgeBeamBarSpacing1} := \begin{cases} \text{"VERIFIED"} & \text{if } s_{f\_bar1.eb} - \phi_{f.bndl.eb} \geq s_{f\_min1.eb} \\ \text{"TOO MANY BARS"} & \text{otherwise} \end{cases}$$

Check\_EdgeBeamBarSpacing1 = "VERIFIED"

The area of FRP reinforcement is:

$$A_{f1.eb} := N_{f\_des1.eb} \cdot \text{area}_{No_{pr.slab}} = 4.91 \cdot \text{in}^2$$

The FRP reinforcement ratio is:

$$\rho_{f1.eb} := \frac{A_{f1.eb}}{b_{eb} \cdot d_{f1.eb}} = 0.02619$$

### **Limit for Reinforcement-Minimum Reinforcement**

[AASHTO GFRP 2009, 2.9.3.3-1]

$$A_{f.min.eb} := \max(0.33 \text{ ksi}, 0.16 \cdot \sqrt{f_{c.super} \text{ ksi}}) \cdot \frac{b_{eb} \cdot d_{f1.eb}}{f_{fd.pr.slab}} = 0.9 \cdot \text{in}^2$$

$$\text{Check\_EdgeBeamFlexureMinReinforcement} := \begin{cases} \text{"VERIFIED"} & \text{if } A_{f1.eb} \geq A_{f.min.eb} \\ \text{"NOT VERIFIED"} & \text{otherwise} \end{cases}$$

Check\_EdgeBeamFlexureMinReinforcement = "VERIFIED"

The edge beam using GFRP is chosen to be over-reinforced, which means that failure of the component is initiated by crushing of the concrete. The strength reduction factor  $\phi_{f\_bar1.eb}$  is:

[AASHTO GFRP 2009, 2.9.2.1]

$$\phi_{f\_bar1.eb} := \begin{cases} 0.55 & \text{if } \rho_{f1.eb} \leq \rho_{fb1.eb} \\ 0.3 + 0.25 \cdot \frac{\rho_{f1.eb}}{\rho_{fb1.eb}} & \text{if } \rho_{fb1.eb} \leq \rho_{f1.eb} \leq 1.4 \cdot \rho_{fb1.eb} \\ 0.65 & \text{if } \rho_{f1.eb} \geq 1.4 \cdot \rho_{fb1.eb} \end{cases} = 0.65$$



### **B3. Negative moment region - flexural strength at support**



$$\text{diam}_{No_{pr.slab}} = 1.25 \cdot \text{in}$$

Diameter of deck primary GFRP reinforcement

$$\text{area}_{No_{pr.slab}} = 1.23 \cdot \text{in}^2$$

Area of deck primary GFRP reinforcement

$$N_{f\_bar1.eb} = 2$$

Number of 2 bundled GFRP bars per foot width for negative moment



$A_{f1.eb} = 4.91 \cdot \text{in}^2$  Area of 2 bundled GFRP bars per foot width for negative moment

$M_{r.neg.eb} = 94 \cdot \text{kip} \cdot \text{ft}$  Maximum negative moment demand

$f_{fd.pr.slab} = 70.9 \cdot \text{ksi}$  Design strength of primary reinforcement for slab

The maximum tensile stress is computed as follows:

[AASHTO GFRP 2009, 2.9.3.1-1]

$$f_{f1.eb} := \begin{cases} \sqrt{\frac{[(E_{fNo_{pr.slab}}) \cdot \epsilon_{cu}]^2}{4} + \frac{0.85 \beta_{1.super} \cdot f_{c.super} \cdot E_{fNo_{pr.slab}} \cdot \epsilon_{cu} - 0.5 E_{fNo_{pr.slab}} \cdot \epsilon_{cu}}{\rho_{f1.eb}}} & \text{if } \rho_{f1.eb} \geq \rho_{fb1.eb} \\ f_{fu} & \text{otherwise} \end{cases}$$

$f_{f1.eb} = 41.2 \cdot \text{ksi}$

$f_f$  cannot exceed  $f_{fu}$ , therefore, the following has to be checked:

CheckEdgeBeamMaxStress1 :=  $\begin{cases} \text{"VERIFIED"} & \text{if } f_{f1.eb} \leq f_{fd.pr.slab} \\ \text{"REDUCE BAR SPACING OR INCREASE BAR SIZE"} & \text{otherwise} \end{cases}$

CheckEdgeBeamMaxStress1 = "VERIFIED"

The stress-block depth is computed as per Eq. 2.9.3.2.2-2 or Eq. 2.9.3.2.2-4 whether  $\rho_f > \rho_{fb}$  or  $\rho_f < \rho_{fb}$ , respectively.

$$a_{f1.eb} := \frac{A_{f1.eb} \cdot f_{f1.eb}}{0.85 \cdot f_{c.super} \cdot b_{eb}} = 4.41 \cdot \text{in} \quad \text{[AASHTO GFRP 2009, 2.9.3.2.2-2]}$$

Neutral axis depth  $c_b$  at balanced strain conditions:

$$c_{b1.eb} := \left( \frac{\epsilon_{cu}}{\epsilon_{cu} + \epsilon_{fdNo_{pr.slab}}} \right) \cdot d_{f1.eb} = 3.5 \cdot \text{in} \quad \text{[AASHTO GFRP 2009, 2.9.3.2.2-4]}$$

The nominal moment capacity is: [AASHTO GFRP 2009, 2.9.3.2.2-1, 2.9.3.2.2-3]

$$M_{nAASHTO\_1.eb} := \begin{cases} A_{f1.eb} \cdot f_{f1.eb} \cdot \left( d_{f1.eb} - \frac{a_{f1.eb}}{2} \right) & \text{if } \rho_{f1.eb} \geq \rho_{fb1.eb} \\ A_{f1.eb} \cdot f_{f1.eb} \cdot \left( d_{f1.eb} - \frac{\beta_{1.super} \cdot c_{b1.eb}}{2} \right) & \text{otherwise} \end{cases}$$

$M_{nAASHTO\_1.eb} = 226.1 \cdot \text{kip} \cdot \text{ft}$



Recall the strength reduction factor for slab:

[AASHTO GFRP 2009, 2.12.1.2.1]

$\phi_{f\_bar1.eb} = 0.65$

The design flexural strength is computed as:

$$\phi_f \text{bar1.eb} \cdot M_{n\text{AASHTO}_1\text{.eb}} = 147 \cdot \text{kip} \cdot \text{ft}$$

$$M_{r\text{.neg.eb}} = 94 \cdot \text{kip} \cdot \text{ft}$$

$$\text{Check\_EB\_FlexureAASHTO}_1 := \begin{cases} \text{"VERIFIED"} & \text{if } \phi_f \text{bar1.eb} \cdot M_{n\text{AASHTO}_1\text{.eb}} \geq M_{r\text{.neg.eb}} \\ \text{"NOT VERIFIED"} & \text{otherwise} \end{cases}$$

$$\text{Check\_SlabFlexureAASHTO}_1 = \text{"VERIFIED"}$$



#### B4. Development length at support



At least 1/3 of the total tension reinforcement provided for negative moment at a support shall have an embedment length  $L_{d\text{.neg.min}}$  beyond the point of inflection as follows:

[AASHTO LRFD 2009, 2.12.1.2.1]

$$L_{d\text{.neg.min.eb}} := \max(d_{f1\text{.eb}}, 12 \cdot \text{diam}_{\text{No.pr.slab}}, 0.0625 \cdot L_{\text{span}}) = 2.2 \cdot \text{ft}$$

1/2 of reinforcement has an embedment length beyond the point of inflection that is chosen to be 2.5 ft

Also, based on the bending moment envelope, the negative moment extends about 12 ft from the support. Therefore, 1/2 of reinforcement for negative moment should have a length 17 ft, distributed 7 ft to the left support B and 10 ft to the right support B (assuming B is the interior support between the first and second spans). At support C, the length is 17 ft distributed symmetrically (assuming C is the interior support connecting the second and third spans).

The remaining 1/2 of reinforcement for negative moment are distributed along the entire span of bridge.

Lap splices are covered at end of the flexural design (section B7).



#### B5. Positive moment region - flexural strength at middle span



$\text{diam}_{\text{No.pr.slab}} = 1.25 \cdot \text{in}$	Diameter of deck primary GFRP reinforcement
$\text{area}_{\text{No.pr.slab}} = 1.23 \cdot \text{in}^2$	Area of deck primary GFRP reinforcement
$N_{f\_bar1\text{.eb}} = 2$	Number of 2 bundled GFRP bars per foot width for positive moment
$A_{f2\text{.eb}} := A_{f1\text{.eb}} = 4.91 \cdot \text{in}^2$	Area of 2 bundled GFRP bars per foot width for positive moment
$d_{f2\text{.eb}} := d_{f1\text{.eb}} = 15.6 \cdot \text{in}$	The effective reinforcement depth
$S_{f\_bar2\text{.eb}} := s_{f\_bar1\text{.eb}} = 6 \cdot \text{in}$	The reinforcing spacing

$M_{r, \text{pos}, \text{eb}} = 102.5 \cdot \text{kip} \cdot \text{ft}$  Maximum positive moment demand

$$\rho_{f2, \text{eb}} := \frac{A_{f2, \text{eb}}}{b_{\text{eb}} \cdot d_{f2, \text{eb}}} = 0.026 \quad \text{FRP reinforcement ratio}$$

The balanced reinforcement ratio,  $\rho_{fb}$  is:

[AASHTO GFRP 2009, 2.7.4.2-2]

$$\rho_{fb2, \text{eb}} := 0.85 \beta_{1, \text{super}} \cdot \frac{f_{c, \text{super}}}{f_{fd, \text{pr}, \text{slab}}} \cdot \frac{E_{fNo, \text{pr}, \text{slab}} \cdot \epsilon_{cu}}{E_{fNo, \text{pr}, \text{slab}} \cdot \epsilon_{cu} + f_{fd, \text{pr}, \text{slab}}} = 0.01$$

The tensile stress in the GFRP is:

[AASHTO GFRP 2009, 2.9.3.1-1]

$$f_{f2, \text{eb}} := \begin{cases} \sqrt{\frac{(E_{fNo, \text{pr}, \text{slab}} \cdot \epsilon_{cu})^2}{4} + \frac{0.85 \beta_{1, \text{super}} \cdot f_{c, \text{super}}}{\rho_{f2, \text{eb}}} E_{fNo, \text{pr}, \text{slab}} \cdot \epsilon_{cu} - 0.5 E_{fNo, \text{pr}, \text{slab}} \cdot \epsilon_{cu}} & \text{if } \rho_{f2, \text{eb}} \geq \rho_{fb2, \text{eb}} \\ f_{fd, \text{pr}, \text{slab}} & \text{otherwise} \end{cases}$$

$$f_{f2, \text{eb}} = 41.2 \cdot \text{ksi}$$

$f_f$  cannot exceed  $f_{fu}$ , therefore, the following has to be checked:

Recall design strength  $f_{fd, \text{pr}, \text{slab}} = 70.9 \cdot \text{ksi}$

$$\text{CheckEdgeBeamMaxStress2} := \begin{cases} \text{"VERIFIED"} & \text{if } f_{f2, \text{eb}} \leq f_{fd, \text{pr}, \text{slab}} \\ \text{"REDUCE BAR SPACING OR INCREASE BAR SIZE"} & \text{otherwise} \end{cases}$$

CheckEdgeBeamMaxStress2 = "VERIFIED"

The stress-block depth is computed as per Eq. 2.9.3.2.2-2 or Eq. 2.9.3.2.2-4 whether  $\rho_f > \rho_{fb}$  or  $\rho_f < \rho_{fb}$ , respectively.

$$a_{f2, \text{eb}} := \frac{A_{f2, \text{eb}} \cdot f_{f2, \text{eb}}}{0.85 \cdot f_{c, \text{super}} \cdot b_{\text{eb}}} = 4.41 \cdot \text{in} \quad [\text{AASHTO GFRP 2009, 2.9.3.2.2-2}]$$

Neutral axis depth  $c_b$  at balanced strain conditions:

$$c_{b2, \text{eb}} := \left( \frac{\epsilon_{cu}}{\epsilon_{cu} + \epsilon_{fdNo, \text{pr}, \text{slab}}} \right) \cdot d_{f2, \text{eb}} = 3.5 \cdot \text{in} \quad [\text{AASHTO GFRP 2009, 2.9.3.2.2-4}]$$

The nominal moment capacity is: [AASHTO GFRP 2009, 2.9.3.2.2-1, 2.9.3.2.2-3]

$$M_{n\text{AASHTO}_2, \text{eb}} := \begin{cases} A_{f2, \text{eb}} \cdot f_{f2, \text{eb}} \cdot \left( d_{f2, \text{eb}} - \frac{a_{f2, \text{eb}}}{2} \right) & \text{if } \rho_{f2, \text{eb}} \geq \rho_{fb2, \text{eb}} \\ A_{f2, \text{eb}} \cdot f_{f2, \text{eb}} \cdot \left( d_{f2, \text{eb}} - \frac{\beta_{1, \text{super}} \cdot c_{b2, \text{eb}}}{2} \right) & \text{otherwise} \end{cases}$$

$$M_{nAASHTO\_2.eb} = 226.1 \cdot \text{kip} \cdot \text{ft}$$



Recall the strength reduction factor for slab:

[AASHTO GFRP 2009, 2.12.1.2.1]

$$\phi_{f\_bar1.eb} = 0.65$$

The design flexural strength is computed as:

$$\phi_{f\_bar1.eb} \cdot M_{nAASHTO\_2.eb} = 147 \cdot \text{kip} \cdot \text{ft}$$

$$M_{r.pos.eb} = 102.5 \cdot \text{kip} \cdot \text{ft}$$

$$\text{Check\_EB\_FlexureAASHTO\_2} := \begin{cases} \text{"VERIFIED"} & \text{if } \phi_{f\_bar1.eb} \cdot M_{nAASHTO\_2.eb} \geq M_{r.pos.eb} \\ \text{"NOT VERIFIED"} & \text{otherwise} \end{cases}$$

Check\_SlabFlexureAASHTO\_1 = "VERIFIED"



## B6. Development length at middle span



According to [AASHTO GFRP 2009, 2.12.1.2], reinforcement should extend not less than the development length,  $L_{d, pos}$  beyond the point at which it is no longer required to resist flexure, and no more than 50% should be terminated at any section

[AASHTO GFRP 2009, 2.12.1.2]

$$L_{d, pos.eb} := \max \left( t_{eb}, 15 \cdot \text{diam}_{No_{pr.slabs}}, \frac{L_{span}}{20} \right) = 21 \cdot \text{in} \quad [\text{AASHTO GFRP 2009, 2.12.1.2.1}]$$

Therefore, the selected development length  $L_{d, pos.sl}$  is chosen to be 2 ft, which is larger than the required  $L_{d, pos}$

$$L_{d, pos.sl.eb} := 2 \text{ ft}$$

In addition,  $L_{d, pos.sl}$  should also satisfy AASHTO GFRP 2009 equation (2.12.1.2.2-1)

$$L_{d, pos.max.eb} := \frac{M_{nAASHTO\_1.eb}}{V_{rightB\_d.eb}} + 12 \cdot d_{f1.eb} = 363 \cdot \text{in} \quad [\text{AASHTO GFRP 2009, 2.12.1.2.2-1}]$$

$$\text{CheckingEdgeBeamDevelopmentLength}_{pos} := \begin{cases} \text{"VERIFIED"} & \text{if } L_{d, pos.sl.eb} \leq L_{d, pos.max.eb} \\ \text{"NOT VERIFIED"} & \text{otherwise} \end{cases}$$

CheckingEdgeBeamDevelopmentLength<sub>pos</sub> = "VERIFIED"

1/2 of reinforcement has a length beyond the point of inflection that is chosen to be 2 ft.

Based on the bending moment envelope, the positive bending moment in the first and third span extends for 18 ft, and along the second span for 11 ft. Therefore, 1/2 of the reinforcement will have a length of 22 ft for the first and third spans, and 15 ft for the second span.

The remaining 1/2 of reinforcement is distributed along the entire spans of bridge.

Lap splices are covered at end of the flexural design (section B7).



## B7. Reinforcement splices



The lap splice length ( $L_{sp}$ ) should satisfy AASHTO GFRP 2009 2.12.2.1 and 2.12.4

Development length for deformed bars in tension is defined as  $L_{d,tension}$ .

Bar location modification factor  $\alpha$ , takes the value of 1 except for bars with more than 12 in of concrete cast below for which a value of 1.5 shall be adopted.  $\alpha$  is 1.5 for negative moment reinforcement while  $\alpha=1$  for positive moment.

$$\alpha_{neg.eb} := 1.5$$

$$\alpha_{pos.eb} := 1$$

Lap splice for negative moment and positive moment is calculated as follows:

[AASHTO GFRP 2009, Equation 2.10.3.1-1 ]

$$L_{d,tension,neg.eb} := \text{diam}_{No_{pr.slabs}} \cdot \frac{\alpha_{neg.eb} \cdot \frac{f_{f1.eb}}{\sqrt{f_{c.super} \cdot \psi}} - 340}{13.6 + \frac{c_c}{d_{f1.eb}}} = 53.1 \text{ in}$$

$$L_{d,tension,pos.eb} := \text{diam}_{No_{pr.slabs}} \cdot \frac{\alpha_{pos.eb} \cdot \frac{f_{f2.eb}}{\sqrt{f_{c.super} \cdot \psi}} - 340}{13.6 + \frac{c_c}{d_{f2.eb}}} = 25 \text{ in}$$

[AASHTO GFRP 2009, Equation 2.12.4]

$$L_{sp,req,neg.eb} := \max(12 \text{ in}, 1.3 \cdot L_{d,tension,neg.eb}) = 69 \text{ in}$$

$$L_{sp,req,pos.eb} := \max(12 \text{ in}, 1.3 \cdot L_{d,tension,pos.eb}) = 32.6 \text{ in}$$

Therefore, lap splice length  $L_{sp,sl}$  selected is

$$\text{For Negative Moment Region} \quad L_{sp,sl,neg.eb} := 69 \text{ in}$$

$$\text{For Positive Moment Region} \quad L_{sp,sl,pos.eb} := 33 \text{ in}$$

Reduction of splice length for excess of reinforcement [ACI318-14 25.4.10]. It is suggested to adopt a limit of 0.6:

$$\text{area}_{required,neg} := \frac{M_{r,neg.eb}}{f_{fd,pr.slabs} \left( d_{f1.slabs} - \frac{\beta_{1,super} \cdot c_{b1.slabs}}{2} \right)} = 1.1 \cdot \text{in}^2 \quad [\text{AASHTO GFRP 2009, 2.9.3.2.2-3}]$$

$$\text{area}_{\text{required.pos}} := \frac{M_{r,\text{pos.eb}}}{f_{\text{fd.pr.slab}} \left( d_{\text{fl.slab}} - \frac{\beta_{1,\text{super}} \cdot c_{\text{b1.slab}}}{2} \right)} = 1.2 \cdot \text{in}^2 \quad [\text{AASHTO GFRP 2009, 2.9.3.2.2-3}]$$

Area per linear foot required at midspan and support, considering the section under-reinforced ( $\rho_f < \rho_{fb}$ )

$$\text{area}_{\text{provided.eb}} := A_{\text{fl.slab}} = 3.7 \cdot \text{in}^2 \quad \text{area per linear foot provided at midspan and support (symmetric)}$$

$$\text{over\_reinf\_ratio}_{\text{eb.neg}} := \begin{cases} \frac{\text{area}_{\text{required.neg}}}{\text{area}_{\text{provided}}} & \text{if } \frac{\text{area}_{\text{required.neg}}}{\text{area}_{\text{provided}}} \geq 0.6 \\ 0.6 & \text{otherwise} \end{cases}$$

$$\text{over\_reinf\_ratio}_{\text{eb.pos}} := \begin{cases} \frac{\text{area}_{\text{required.pos}}}{\text{area}_{\text{provided}}} & \text{if } \frac{\text{area}_{\text{required.pos}}}{\text{area}_{\text{provided}}} \geq 0.6 \\ 0.6 & \text{otherwise} \end{cases}$$

$$\text{over\_reinf\_ratio}_{\text{eb.neg}} = 0.6$$

$$\text{over\_reinf\_ratio}_{\text{eb.pos}} = 0.6$$

$$L_{\text{tension.neg.reduced.eb}} := L_{\text{d.tension.neg.eb}} \cdot \text{over\_reinf\_ratio}_{\text{eb.neg}} = 31.8 \cdot \text{in} \quad [\text{ACI318-14 25.4.10}]$$

$$L_{\text{tension.pos.reduced.eb}} := L_{\text{d.tension.pos.eb}} \cdot \text{over\_reinf\_ratio}_{\text{eb.pos}} = 15 \cdot \text{in} \quad [\text{ACI318-14 25.4.10}]$$

Lap splice length  $L_{\text{sp,sl}}$  :

$$L_{\text{sp.neg.eb}} := \max(12 \cdot \text{in}, 1.3 \cdot L_{\text{tension.neg.reduced.eb}}) = 41 \cdot \text{in} \quad [\text{AASHTO GFRP 2009, 2.12.4}]$$

$$L_{\text{sp.pos.eb}} := \max(12 \cdot \text{in}, 1.3 \cdot L_{\text{tension.pos.reduced.eb}}) = 20 \cdot \text{in} \quad [\text{AASHTO GFRP 2009, 2.12.4}]$$



## C. Shear Verification



The nominal shear resistance provide by concrete,  $V_c$

$$b_{\text{eb}} = 12 \cdot \text{in} \quad \text{unitary width}$$

$$c_{1.\text{eb}} := \frac{a_{\text{fl.eb}}}{\beta_{1,\text{super}}} = 5.3 \cdot \text{in} \quad \text{neutral axis depth at support}$$

$$c_{2.\text{eb}} := \frac{a_{\text{fl.eb}}}{\beta_{1,\text{super}}} = 5.3 \cdot \text{in} \quad \text{neutral axis depth at middle span}$$

$$V_{c1.\text{eb}} := 0.16 \sqrt{f_{c,\text{super}} \cdot \text{ksi}} \cdot b_{\text{eb}} \cdot c_{1.\text{eb}} = 21.8 \cdot \text{kip} \quad [\text{AASHTO GFRP 2009, 2.7.4.2}]$$

Resistance factor  $\phi_v$  for shear is 0.75 [AASHTO GFRP 2009, 2.7.4.2]

CheckEdgeBeamShear :=  $\begin{cases} \text{"VERIFIED, NO STIRRUP REQUIRED"} & \text{if } V_{\text{rightB\_d.eb}} \leq \phi_v \cdot V_{c1.eb} \\ \text{"REDESIGN"} & \text{otherwise} \end{cases}$

CheckEdgeBeamShear = "VERIFIED, NO STIRRUP REQUIRED"



## D. Crack Width Verification

### D1. Data recall (section B of chapter 1.04)



Crack width is checked using Equation 2.9.3.4-1 of AASHTO GFRP 2009. A crack width limit,  $w_{lim}$  of 0.020 in. is used.

$w_{lim} = 0.02 \cdot \text{in}$	Crack width limit
$\text{diam}_{\text{No.pr.slab}} = 1.25 \cdot \text{in}$	Diameter of deck primary GFRP reinforcement
$\text{area}_{\text{No.pr.slab}} = 1.23 \cdot \text{in}^2$	Area of deck primary GFRP reinforcement
$E_{f\text{No.pr.slab}} = 7142 \cdot \text{ksi}$	Modulus of elasticity of deck primary GFRP reinforcement
$f_{fu\text{No.pr.slab}} = 101.3 \cdot \text{ksi}$	Tensile strength of deck primary reinforcement for product certification as reported by GFRP manufacturer [AASHTO GFRP 2009, 2.6.1.2]
$f_{fd.pr.slab} = 70.9 \cdot \text{ksi}$	Design strength of deck primary reinforcement considering reduction for service environment [AASHTO GFRP 2009, 2.6.1.2-1]
$\epsilon_{fu\text{No.pr.slab}} = 1.5 \cdot \%$	Tensile strain of deck primary reinforcement for product certification as reported by GFRP manufacturer [AASHTO GFRP 2009, 2.6.1.2]
$\epsilon_{fd\text{No.pr.slab}} = 1.1 \cdot \%$	Design strain of deck primary reinforcement reinforcement considering reduction for service environment



### D2. Support



Recall crack width limit

$$w_{lim} = 0.02 \cdot \text{in}$$

Ratio of modulus of elasticity of bars to modulus of elasticity of concrete

$$n_{f.eb} := \frac{E_{f\text{No.pr.slab}}}{E_{c.super}} = 2.1$$

Ratio of depth of neutral axis to reinforcement depth

$$k_{1.eb} := \sqrt{2\rho_{f1.eb} \cdot n_{f.eb} + (\rho_{f1.eb} \cdot n_{f.eb})^2} - \rho_{f1.eb} \cdot n_{f.eb} = 0.3$$

Tensile stress in GFRP under service loads

$$f_{fs1.eb} := \frac{M_{neg.eb}}{A_{f1.eb} \cdot d_{f1.eb} \cdot \left(1 - \frac{k_{1.eb}}{3}\right)} = 10.8 \cdot \text{ksi}$$

Ratio of distance from neutral axis to extreme tension fiber to distance from neutral axis to center of tensile reinforcement

$$\beta_{11.eb} := \frac{t_{eb} - k_{1.eb} \cdot d_{f1.eb}}{d_{f1.eb} \cdot (1 - k_{1.eb})} = 1.2$$

Thickness of concrete cover measured from extreme tension fiber to center of bar

$$d_{c1.eb} := t_{eb} - d_{f1.eb} = 2.4 \cdot \text{in}$$

Bond factor (provided by the manufacturer)

$$k_b = 0.9$$

The crack width under service loads is: [AASHTO GFRP 2009, 2.9.3.4-1]

$$w_{1.eb} := 2 \frac{f_{fs1.eb}}{E_{fNo_{pr.slab}}} \beta_{11.eb} \cdot k_b \cdot \sqrt{d_{c1.eb}^2 + \left(\frac{s_{f\_bar1.eb}}{2}\right)^2} = 0.013 \cdot \text{in}$$

The crack width limit is:

$$w_{lim} = 0.02 \cdot \text{in}$$

$$\text{Check\_EdgeBeamCrack1} := \begin{cases} \text{"VERIFIED"} & \text{if } w_{1.eb} \leq w_{lim} \\ \text{"NOT VERIFIED"} & \text{otherwise} \end{cases}$$

Check\_EdgeBeamCrack1 = "VERIFIED"

The maximum recommended bar spacing to limit cracking is:

[ACI 440.1R]

$$s_{Ospina\_1.eb} := \min \left( 1.15 \cdot \frac{E_{fNo_{pr.slab}} \cdot w_{lim}}{f_{fs1.eb} \cdot k_b} - 2.5 \cdot c_c, 0.92 \cdot \frac{E_{fNo_{pr.slab}} \cdot w_{lim}}{f_{fs1.eb} \cdot k_b} \right) = 13.2 \cdot \text{in}$$

$$\text{Check\_EdgeBeamSpacing1} := \begin{cases} \text{"VERIFIED"} & \text{if } s_{f\_bar1.eb} \leq s_{Ospina\_1.eb} \\ \text{"NOT VERIFIED"} & \text{otherwise} \end{cases}$$

Check\_EdgeBeamSpacing1 = "VERIFIED"



### D3. Middle Span





Recall crack width limit

$$w_{lim} = 0.02 \cdot \text{in}$$

Ratio of modulus of elasticity of bars to modulus of elasticity of concrete

$$n_{f,eb} = 2.1$$

Ratio of depth of neutral axis to reinforcement depth

$$k_{2,eb} := k_{1,eb} = 0.3$$

Bar spacing

$$s_{f\_bar2,eb} := s_{f\_bar1,eb} = 6 \cdot \text{in}$$

Tensile stress in GFRP under service loads

$$f_{fs2,eb} := \frac{M_{pos,eb}}{A_{f2,eb} \cdot d_{f2,eb} \cdot \left(1 - \frac{k_{2,eb}}{3}\right)} = 11.3 \cdot \text{ksi}$$

Ratio of distance from neutral axis to extreme tension fiber to distance from neutral axis to center of tensile reinforcement

$$\beta_{12,eb} := \frac{t_{eb} - k_{2,eb} \cdot d_{f2,eb}}{d_{f2,eb} \cdot (1 - k_{2,eb})} = 1.2$$

Thickness of concrete cover measured from extreme tension fiber to center of bar

$$d_{c2,eb} := t_{eb} - d_{f2,eb} = 2.4 \cdot \text{in}$$

Bond factor (provided by the manufacturer)

$$k_b = 0.9$$

The crack width under service loads is:

[AASHTO GFRP 2009, 2.9.3.4-1]

$$w_{2,eb} := 2 \frac{f_{fs2,eb}}{E_{fNo\_pr,slab}} \beta_{11,eb} \cdot k_b \cdot \sqrt{d_{c1,eb}^2 + \left(\frac{s_{f\_bar1,eb}}{2}\right)^2} = 0.013 \cdot \text{in}$$

The crack width limit is:

$$w_{lim} = 0.02 \cdot \text{in}$$

$$\text{Check\_EdgeBeamCrack2} := \begin{cases} \text{"VERIFIED"} & \text{if } w_{2,eb} \leq w_{lim} \\ \text{"NOT VERIFIED"} & \text{otherwise} \end{cases}$$

Check\_EdgeBeamCrack2 = "VERIFIED"

The maximum recommended bar spacing to limit cracking is:

[ACI 440.1R 9.1.3(a)]

$$s_{\text{Ospina\_2.eb}} := \min \left( 1.15 \cdot \frac{E_{f\text{No.pr.slab}} \cdot w_{\text{lim}}}{f_{fs2.eb} \cdot k_b} - 2.5 \cdot c_c, 0.92 \cdot \frac{E_{f\text{No.pr.slab}} \cdot w_{\text{lim}}}{f_{fs2.eb} \cdot k_b} \right) = 12.4 \cdot \text{in}$$

$$\text{Check\_EdgeBeamSpacing2} := \begin{cases} \text{"VERIFIED"} & \text{if } s_{f\_bar2.eb} \leq s_{\text{Ospina\_2.eb}} \\ \text{"NOT VERIFIED"} & \text{otherwise} \end{cases}$$

Check\_EdgeBeamSpacing2 = "VERIFIED"



## E. Fatigue and Creep Rupture

### E1. Data Recall



#### GFRP creep rupture limit stress

Creep rupture stress limitation factor

$$k_{\text{creep\_R}} = 0.2 \quad [\text{AASHTO GFRP 2009, 2.7.3-1}]$$

$$f_{f\_creep} = 14.2 \cdot \text{ksi} \quad \text{Creep and fatigue rupture limit stress}$$

$$\text{diam}_{\text{No.pr.slab}} = 1.25 \cdot \text{in} \quad \text{Diameter of deck primary GFRP reinforcement}$$

$$\text{area}_{\text{No.pr.slab}} = 1.23 \cdot \text{in}^2 \quad \text{Area of deck primary GFRP reinforcement}$$

$$E_{f\text{No.pr.slab}} = 7142 \cdot \text{ksi} \quad \text{Modulus of elasticity of deck primary GFRP reinforcement}$$

$$f_{fu\text{No.pr.slab}} = 101.3 \cdot \text{ksi} \quad \text{Tensile strength of deck primary reinforcement for product certification as reported by GFRP manufacturer [AASHTO GFRP 2009, 2.6.1.2]}$$

$$f_{fd.pr.slab} = 70.9 \cdot \text{ksi} \quad \text{Design strength of deck primary reinforcement considering reduction for service environment [AASHTO GFRP 2009, 2.6.1.2-1]}$$

$$\epsilon_{fu\text{No.pr.slab}} = 1.5\% \quad \text{Tensile strain of deck primary reinforcement for product certification as reported by GFRP manufacturer [AASHTO GFRP 2009, 2.6.1.2]}$$

$$\epsilon_{fd\text{No.pr.slab}} = 1.1\% \quad \text{Design strain of deck primary reinforcement considering reduction for service environment [AASHTO GFRP 2009, 2.6.1.2]}$$



### E2. Support



The stress level in the GFRP reinforcement for checking creep rupture failure is evaluated considering the total unfactored dead loads.

$$M_{1\_creep.eb} := M_{\text{fatigue.neg.eb}} = 77.9 \cdot \text{ft} \cdot \text{kip} \quad \text{Bending moment due to dead load}$$

$$f_{f\_creep} = 14.2 \cdot \text{ksi} \quad \text{The GFRP creep and fatigue rupture limit stress}$$

$$n_{f,eb} = 2.1$$

Ratio of modulus of elasticity of bars to modulus of elasticity of concrete

$$k_{1,eb} = 0.3$$

Ratio of depth of neutral axis to reinforcement depth.

The tensile stress in the FRP is:

$$f_{f1\_creep,eb} := \frac{M_{1\_creep,eb}}{A_{f1,eb} \cdot d_{f1,eb} \left(1 - \frac{k_{1,eb}}{3}\right)} = 13.4 \text{ ksi}$$

$$\text{Check\_EdgeBeamCreep1} := \begin{cases} \text{"VERIFIED"} & \text{if } f_{f1\_creep,eb} \leq f_{f\_creep} \\ \text{"NOT VERIFIED"} & \text{otherwise} \end{cases}$$

$$\text{Check\_EdgeBeamCreep1} = \text{"VERIFIED"}$$



### E3. Middle span



$$M_{2\_creep,eb} := M_{\text{fatigue,pos,eb}} = 77.3 \cdot \text{ft} \cdot \text{kip}$$

Bending moment due to dead load

$$f_{f\_creep} = 14.2 \cdot \text{ksi}$$

The GFRP creep and fatigue rupture limit stress

$$n_{f,eb} = 2.1$$

Ratio of modulus of elasticity of bars to modulus of elasticity of concrete

$$k_{2,eb} = 0.3$$

Ratio of depth of neutral axis to reinforcement depth

$$f_{f2\_creep,eb} := \frac{M_{2\_creep,eb}}{A_{f2,eb} \cdot d_{f2,eb} \left(1 - \frac{k_{2,eb}}{3}\right)} = 13.3 \cdot \text{ksi}$$

$$\text{Check\_EdgeBeamCreep2} := \begin{cases} \text{"VERIFIED"} & \text{if } f_{f2\_creep,eb} \leq f_{f\_creep} \\ \text{"NOT VERIFIED"} & \text{otherwise} \end{cases}$$

$$\text{Check\_EdgeBeamCreep2} = \text{"VERIFIED"}$$



## F. Secondary Reinforcement

### F1. Data recall (section B of chapter 1.04)



$$\text{diam}_{\text{No}_{\text{sec,slab}}} = 0.75 \cdot \text{in} \quad \text{Diameter of deck secondary GFRP reinforcement}$$

$$\text{area}_{\text{No}_{\text{sec,slab}}} = 0.44 \cdot \text{in}^2 \quad \text{Area of deck secondary GFRP reinforcement}$$

$$E_{f\text{No}_{\text{sec,slab}}} = 7208 \cdot \text{ksi} \quad \text{Modulus of elasticity of deck secondary GFRP reinforcement}$$

$f_{fuNo_{sec.slab}} = 109.4 \text{ ksi}$	Tensile strength of deck secondary reinforcement for product certification as reported by GFRP manufacturer [AASHTO GFRP 2009, 2.6.1.2]
$f_{fd.sec.slab} = 76.6 \text{ ksi}$	Design strength of deck secondary reinforcement considering reduction for service environment [AASHTO GFRP 2009, 2.6.1.2-1]
$\epsilon_{fuNo_{sec.slab}} = 1.6\%$	Tensile strain of deck secondary reinforcement for product certification as reported by GFRP manufacturer [AASHTO GFRP 2009, 2.6.1.2]
$\epsilon_{fdNo_{sec.slab}} = 1.1\%$	Design strain of deck secondary reinforcement reinforcement considering reduction for service environment [AASHTO GFRP 2009, 2.6.1.2]
<p>▲</p> <p><b>F2.Disribution reinforcement</b></p> <p>▼</p>	
<p>Reinforcement shall be placed in the secondary direction at the bottom of the slab as at most 50% of the primary reinforcement for positive memento as follows:</p> <p>[AASHTO GFRP 2009, 2.11.4.2]</p> <p>For primary reinforcement parallel to traffic:</p> <p><math>A_{f2.eb} = 4.91 \cdot \text{in}^2</math></p> <p>The required secondary reinforcement <math>A_{sec.req}</math></p> $A_{sec.req.eb} := \min\left(50\%, \frac{100\%}{\sqrt{\frac{L_{span}}{ft}}}\right) \cdot A_{f2.eb} = 0.8 \cdot \text{in}^2 \quad [\text{AASHTO GFRP 2009, 2.11.4.1}]$ <p>The design width in the transverse direction is</p> <p><math>b_{trans.eb} := 12 \text{ in}</math></p> <p>The required number of bars for secondary reinforcement <math>N_{sec.req}</math></p> <p>Recall <math>diam_{No_{sec.slab}} = 0.8 \cdot \text{in}</math>    <math>area_{No_{sec.slab}} = 0.4 \cdot \text{in}^2</math></p> $N_{sec.req.eb} := \frac{A_{sec.req.eb}}{area_{No_{sec.slab}}} = 1.9$ <p>The design number of bars for secondary reinforcement <math>N_{sec.des}</math> is selected to be 2</p> <p><math>N_{sec.des.eb} := 2</math></p> <p>Spacing for <math>A_{sec.req}</math> is <math>S_{sec.req}</math>, considering the maximum spacing requirement</p> $S_{sec.max.eb} := \min(0.5 \cdot t_{eb}, 24 \text{ in}) = 9 \cdot \text{in} \quad [\text{AASHTO GFRP 2009, 2.10.2.2.4}]$ <p>Spacing for minimum spacing</p> $S_{sec.min.eb} := \min\left(1.5 \cdot diam_{No_{sec.slab}}, 1.5 \text{ in}\right) = 1.1 \cdot \text{in} \quad [\text{AASHTO GFRP 2009, 2.11.3}]$	

Therefore, the spacing for secondary reinforcement ( $S_{\text{sec.sl}})$  is:

$$S_{\text{sec.sl.eb}} := \frac{b_{\text{trans.eb}}}{N_{\text{sec.des.eb}}} = 6 \cdot \text{in}$$

$$\text{CheckingEdgeBeamSecondarySpacing} := \begin{cases} \text{"VERIFIED"} & \text{if } S_{\text{sec.min.eb}} \leq S_{\text{sec.sl.eb}} \leq S_{\text{sec.max.eb}} \\ \text{"NOT VERIFIED"} & \text{otherwise} \end{cases}$$

CheckingEdgeBeamSecondarySpacing = "VERIFIED"

Use 4 #6 GFRP in 1 ft-width of transverse direction for transverse reinforcement. The spacing between two #6 GFRP bars is 6" center to center.



## G. Shrinkage and Temperature Reinforcement

### G1.Data recall (section B of chapter 1.04)



$\text{diam}_{\text{No}_{\text{sec.slab}}} = 0.8 \cdot \text{in}$	Diameter of deck secondary GFRP reinforcement
$\text{area}_{\text{No}_{\text{sec.slab}}} = 0.4 \cdot \text{in}^2$	Area of deck secondary GFRP reinforcement
$E_{f\text{No}_{\text{sec.slab}}} = 7208 \cdot \text{ksi}$	Modulus of elasticity of deck secondary GFRP reinforcement
$f_{fu\text{No}_{\text{sec.slab}}} = 109.4 \cdot \text{ksi}$	Tensile strength of deck secondary reinforcement for product certification as reported by GFRP manufacturers [AASHTO GFRP 2009, 2.6.1.2]
$f_{fd.\text{sec.slab}} = 76.6 \cdot \text{ksi}$	Design strength of deck secondary reinforcement considering reduction for service environment [AASHTO GFRP 2009, 2.6.1.2-1]
$\epsilon_{fu\text{No}_{\text{sec.slab}}} = 1.6 \cdot \%$	Tensile strain of deck secondary reinforcement for product certification as reported by GFRP manufacturers [AASHTO GFRP 2009, 2.6.1.2]
$\epsilon_{fd\text{No}_{\text{sec.slab}}} = 1.1 \cdot \%$	Design strain of deck secondary reinforcement considering reduction for service environment [AASHTO GFRP 2009, 2.6.1.2]



The ratio of GFRP shrinkage and temperature reinforcement area to gross concrete area  $\rho_{\text{est}}$ :

$$\text{Modulus of Elasticity of Steel } E_s = 2.9 \times 10^4 \cdot \text{ksi}$$

[AASHTO GFRP 2009, 2.11.5]

$$\rho_{f.\text{st.eb}} := \min \left( \max \left( 0.0014, 0.0018 \cdot \frac{60 \text{ksi}}{f_{fd.\text{sec.slab}}} \cdot \frac{E_s}{E_{f\text{No}_{\text{sec.slab}}}} \right), 0.0036 \right) = 0.0036$$

The design width in the transverse direction:

$$b_{\text{trans.eb}} = 12 \cdot \text{in}$$

$$A_{g.\text{trans.eb}} := b_{\text{trans.eb}} \cdot t_{\text{eb}} = 216 \cdot \text{in}^2$$

GFRP shrinkage and temperature reinforcement area  $A_{st}$

$$A_{st,eb} := \rho_{f,st,eb} \cdot A_{g,trans,eb} = 0.8 \cdot \text{in}^2$$

The number of required reinforcement for shrinkage and temperature  $N_{st,req}$

$$\text{Recall } \text{diam}_{No_{sec,slab}} = 0.8 \cdot \text{in} \quad \text{area}_{No_{sec,slab}} = 0.4 \cdot \text{in}^2$$

$$N_{st,req,eb} := \frac{A_{st,eb}}{\text{area}_{No_{sec,slab}}} = 1.8$$

Therefore, the number of design reinforcement for shrinkage and temperature  $N_{st,des}$  is 1 per top and bottom layer.

$$N_{st,des,eb} := 2$$

Therefore spacing  $S_{st,st}$ .

$$S_{st,prvd,eb} := \frac{b_{trans,eb}}{\frac{N_{st,des,eb}}{2}} = 12 \cdot \text{in}$$

According to Bridge design guide specification for GFRP reinforcement, the max spacing for shrinkage and temperature  $S_{st,max}$

$$S_{st,max,eb} := \min(3 \cdot t_{eb}, 12 \text{in}) = 12 \cdot \text{in}$$

[ASSHTO GFRP 2009, 2.11.5]

$$\text{Check\_EdgeBeam\_ST\_Spacing} := \begin{cases} \text{"VERIFIED"} & \text{if } S_{st,prvd,eb} \leq S_{st,max,eb} \\ \text{"NOT VERIFIED"} & \text{otherwise} \end{cases}$$

$$\text{Check\_EdgeBeam\_ST\_Spacing} = \text{"VERIFIED"}$$

Temperature and shrinkage requirements can be met with a #6@12" top and bottom. Secondary reinforcement requirements are met with a #6@6" bottom. Thus the combined configuration is #6@12" top and #6@6" bottom.



## H. Deflection Verification

### Preliminary Calculations



The maximum allowable deflection due to live load including dynamic effect is:

$$\Delta_{lim,eb} := \frac{L_{span}}{800} = 0.525 \cdot \text{in} \quad [\text{AASHTO GFRP 2009, 2.7.2}]$$

The gross moment of inertia is:

$$I_{g,eb} := \frac{b_{eb} \cdot t_{eb}^3}{12} = 5832 \cdot \text{in}^4$$

The negative cracking moment is:

$$M_{crNeg,eb} := \frac{f_{r,super} \cdot I_{g,eb}}{t_{eb} - c_{1,eb} - c_c} = 21.91 \cdot \text{kip} \cdot \text{ft}$$

The positive cracking moment is:

$$M_{crPos.eb} := \frac{f_{r.super} \cdot I_{g.eb}}{t_{eb} - c_{2.eb} - c_c} = 21.91 \cdot \text{kip} \cdot \text{ft}$$



### Cracked Moment of Inertia



The cracked moment of inertia,  $I_{cr}$ , is computed as follows:

[AASHTO GFRP 2009, 2.7.3-3]

- Case 1: mid-span

$$I_{cr2.eb} := \frac{b_{eb} \cdot d_{f2.eb}^3}{3} k_{2.eb}^3 + n_{f.eb} \cdot A_{f2.eb} \cdot d_{f2.eb}^2 \cdot (1 - k_{2.eb})^2 = 1610 \cdot \text{in}^4$$

- Case 2: Interior support

$$I_{cr1.eb} := \frac{b_{eb} \cdot d_{f1.eb}^3}{3} k_{1.eb}^3 + n_{f.eb} \cdot A_{f1.eb} \cdot d_{f1.eb}^2 \cdot (1 - k_{1.eb})^2 = 1610 \cdot \text{in}^4$$



### Effective Moment of Inertia



The average effective moment of inertia,  $I_e$ , is computed using AASHTO LRFD 2014 Eq. (5.7.3.6.2-1).

The maximum positive bending moment for exterior span due to service loads is:

$$M_{pos.eb} = 65.5 \cdot \text{kip} \cdot \text{ft}$$

The value of  $I_e$  at midspan is:

[AASHTO LRFD 2014, 5.7.3.6.2-1]

$$I_{e2.eb} := \min \left[ I_{g.eb}, \left( \frac{M_{crPos.eb}}{M_{pos.eb}} \right)^3 \cdot I_{g.eb} + \left[ 1 - \left( \frac{M_{crPos.eb}}{M_{pos.eb}} \right)^3 \right] I_{cr2.eb} \right] = 1768 \cdot \text{in}^4$$



### Maximum Deflection



The maximum allowable deflection is:

$$\Delta_{lim.eb} = 0.525 \cdot \text{in}$$

The thickness of slab satisfies the minimum requirement of AASHTO LRFD 2014 Bridge Design Specification Table 2.5.2.6.3-1. The instantaneous deflection to be used for the calculation of the long-time deflection is based on magnification factor multiplied by instantaneous deflection.

Considering the bridge is continuous and simply supported, the exterior span can be assumed to be at pinned at one end and fixed at other. Therefore, deflection formula is according to formula of uniformly loaded fixed-pinned beam

Maximum positive moment due to live load for the exterior span:

$$M_{sPos.eb} = 40.5 \cdot \text{kip} \cdot \text{ft}$$

The instantaneous deflection under live load is:

$$\Delta_{SL.eb.ins} := \frac{8}{185} \cdot \frac{M_{sPos.eb} \cdot L_{span}^2}{E_{c.super} \cdot I_{e2.eb}} = 0.604 \cdot \text{in}$$

The magnification factor for long-term deflection under live loads is taken directly from AASHTO LRFD 2014 Section 5.7.6.3.2-Here the presence of compression reinforcement ( $A'_f=2/3A_{fl.slabb}$ ) is considered even if such reinforcement is not taken into account for strength calculation.

The factor for long-term deflection under service loads:

[AASHTO LRFD 2014, 5.7.6.3.2]

$$\text{factor}_{lt.eb} := \begin{cases} \max \left( 1.6, 3 - 1.2 \cdot \frac{\frac{2}{3} \cdot A_{f1.eb}}{A_{f2.eb}} \right) & \text{if } I_{e2.slabb} < I_{g.slabb} = 2.2 \\ 4 & \text{if } I_{e2.eb} = I_{g.eb} \end{cases}$$

$$\Delta_{SL.eb.lt} := \text{factor}_{lt.eb} \cdot \Delta_{SL.eb.ins} = 1.3 \cdot \text{in}$$

$$\text{Check\_EBInstantaneousDeflection} := \begin{cases} \text{"VERIFIED"} & \text{if } \Delta_{SL.eb.ins} \leq \Delta_{lim.eb} \\ \text{"SERVICEABILITY SUGGESTION IS NOT MET"} & \text{otherwise} \end{cases}$$

Check\_EBInstantaneousDeflection = "SERVICEABILITY SUGGESTION IS NOT MET"

$$\text{Check\_EBLongTermDeflection} := \begin{cases} \text{"VERIFIED"} & \text{if } \Delta_{SL.eb.lt} \leq \Delta_{lim.eb} \\ \text{"SERVICEABILITY SUGGESTION IS NOT MET"} & \text{otherwise} \end{cases}$$

Check\_EBLongTermDeflection = "SERVICEABILITY SUGGESTION IS NOT MET"

Even though the instantaneous and long-time deflections are higher than the maximum allowable deflection, the design is considered satisfactory as the effect of flat slab is disregarded. More sofisticated tools could be considered for the computation of deflection.



## I. Summary of Provided Reinforcement and Detailing

### Primary reinforcement



$N_{o.pr.slabb} = 10$	Bar number of primary reinforcement (top and bottom)
$N_{f\_bar1.eb} = 2$	Number of 2 bundled bars per ft
$s_{f\_bar1.eb} = 6 \cdot \text{in}$	Spacing
$L_{d.neg.min.eb} = 2.2 \text{ ft}$	Development length for negative moment region



$L_{d,pos.sl.eb} = 2\text{ ft}$       Development length for positive moment region

$L_{sp.sl.neg.eb} = 5.8\text{ ft}$       Splice length for negative moment region

$L_{sp.sl.pos.eb} = 2.8\text{ ft}$       Splice length for positive moment region

Primary Reinforcement-Section View

Edge beam region

Flat slab region

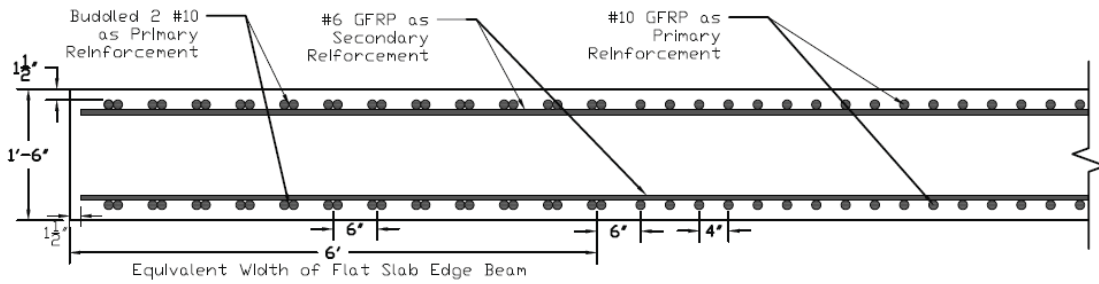

**Secondary reinforcement**



$N_{o\_sec.slab} = 6$  Bar number of secondary reinforcement (top and bottom)

$S_{sec.sl.t.eb} = 6 \cdot in$  Bar spacing

$N_{st.des.eb} = 1.2$  Number of bars per ft (top and bottom)

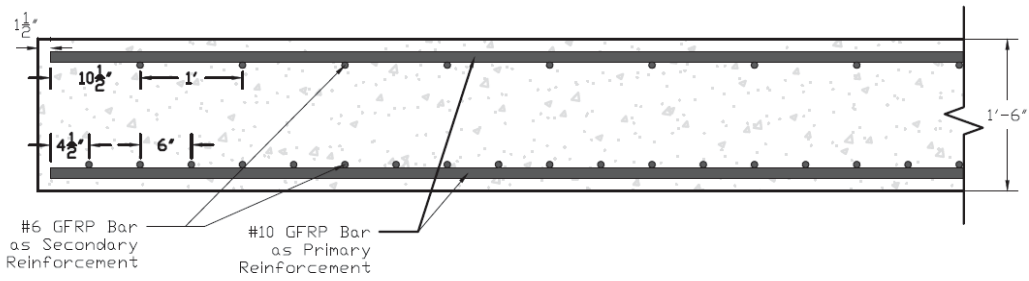

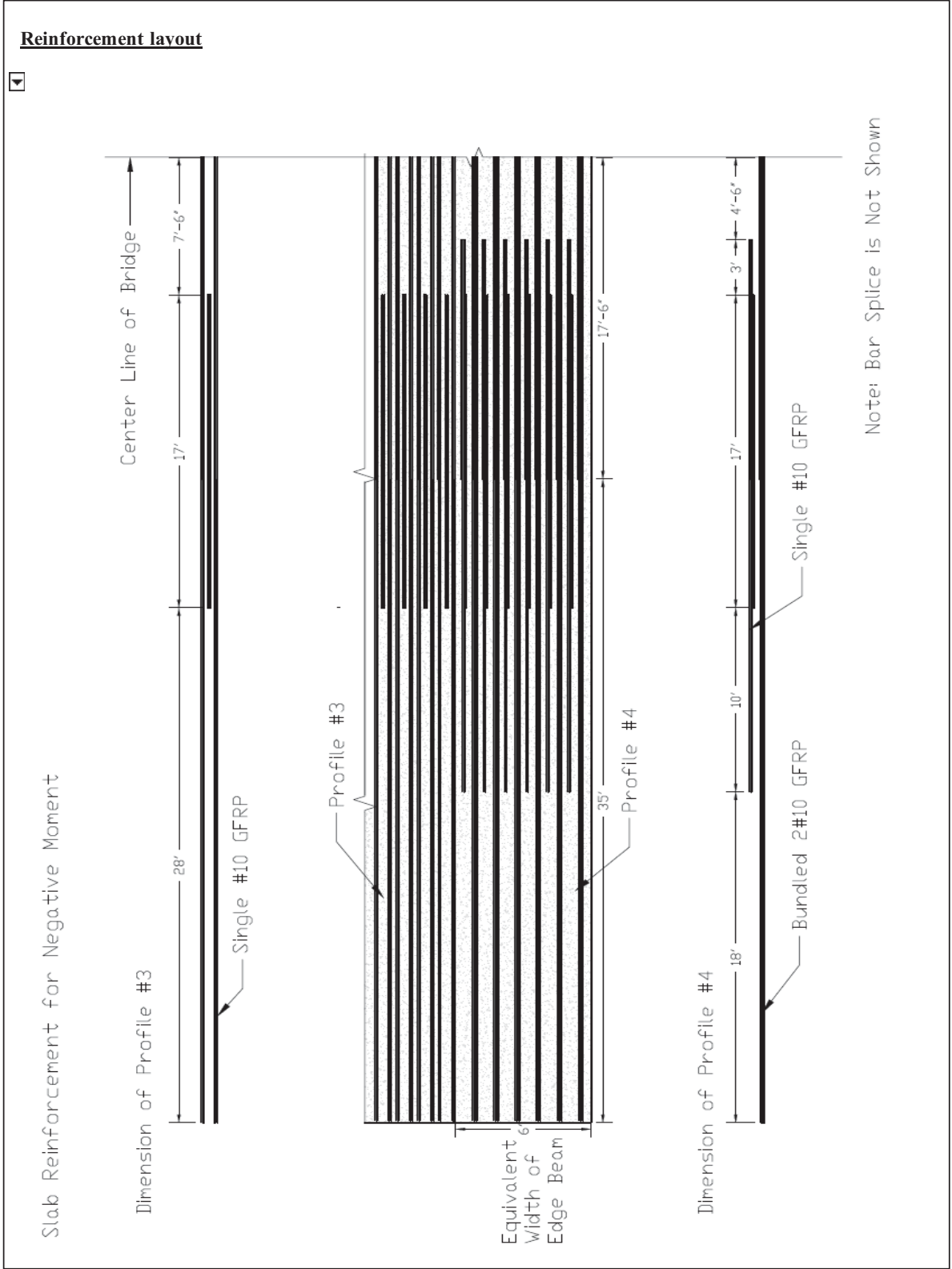

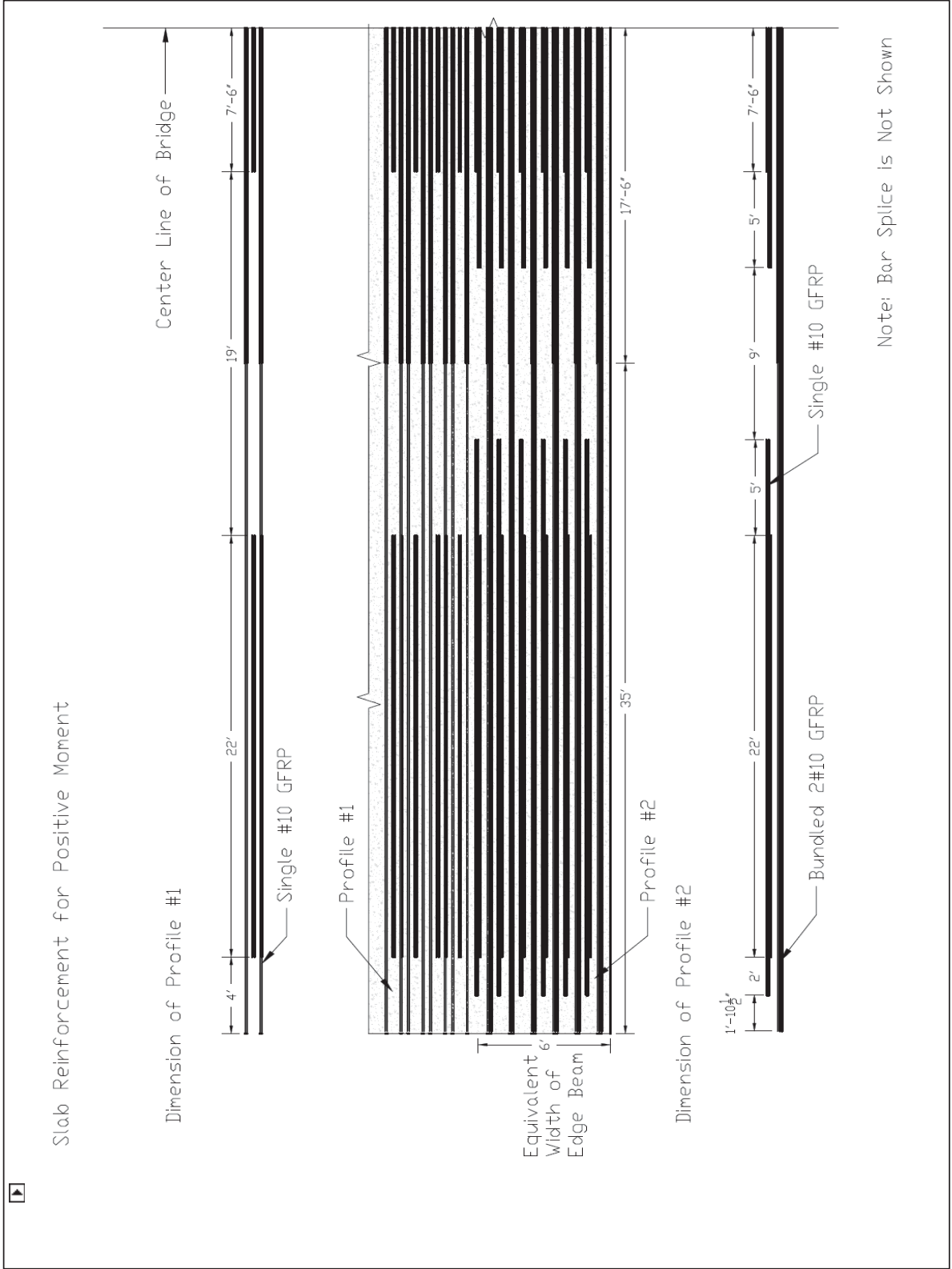



## SUPERSTRUCTURE DESIGN

### GFRP-Reinforced Traffic Barrier Design

#### References (links to other Mathcad files)

-  Reference:C:\Users\Angiolo\Desktop\MStthesis\_Valentino\_Rinaldi\LRFD\_Design\_Example\_#2A thesis\1.03.Design\_Parameters.xmc
-  Reference:C:\Users\Angiolo\Desktop\MStthesis\_Valentino\_Rinaldi\LRFD\_Design\_Example\_#2A thesis\1.04.Material\_Properties.xmc
-  Reference:C:\Users\Angiolo\Desktop\MStthesis\_Valentino\_Rinaldi\LRFD\_Design\_Example\_#2A thesis\2.01.Flat\_Slab\_Design\_Load
-  Reference:C:\Users\Angiolo\Desktop\MStthesis\_Valentino\_Rinaldi\LRFD\_Design\_Example\_#2A thesis\2.02.GFRP\_Flat\_Slab\_Design.
-  Reference:C:\Users\Angiolo\Desktop\MStthesis\_Valentino\_Rinaldi\LRFD\_Design\_Example\_#2A thesis\2.03.Edge\_Beam\_Design\_Lo
-  Reference:C:\Users\Angiolo\Desktop\MStthesis\_Valentino\_Rinaldi\LRFD\_Design\_Example\_#2A thesis\2.04.GFRP\_Edge\_Beam\_Desig

#### Description

This section provides the design for the GFRP-reinforced traffic barrier superstructure.

<b>Page</b>	<b>Contents</b>
93	<b>A. Type and Geometry</b>
94	<b>B. Development Length and Reinforcement Splices</b>
95	<b>C. Design Loads</b>
96	<b>D. Corner Joint Verification</b>
98	<b>E. Flexural Verification</b>
	<b>E1. Limits for Reinforcement</b>
	<b>E2. Flexural Strength</b>
99	<b>F. Shear Verification</b>
	<b>F1. Concrete Shear Strength</b>
	<b>F2. Shear Reinforcement Strength</b>
103	<b>G. Summary of Provided Reinforcement and Detailing</b>

### A. Type and Geometry



Type of traffic barrier : Concrete parapet [AASHTO LRFD 2014, A13.1.1]

Geometrical model: Section Thru New Jersey Shape Railing 32 in in height [FDOT 2014, pag.54]

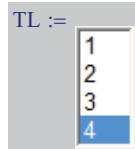

TL = 4 Test Level [AASHTO LRFD 2014, 13.7.2]

Traffic railings should be at least 42 in for TL-5 and 90 in for TL-6 [AASHTO LRFD 2014, 13.7.3.2].

Concrete clear cover  $c_c = 1.5 \cdot \text{in}$

Spacing for deck secondary reinforcement  $t_{\text{slab}} = 18 \cdot \text{in}$

Bridge deck thickness  $S_{\text{sec.sl.t.eb}} = 6 \cdot \text{in}$

Note: clear cover can be smaller than 2 in, being corrosion not an issue for GFRP

Fig.CA13.3.1-2 AASHTO LRFD 2012

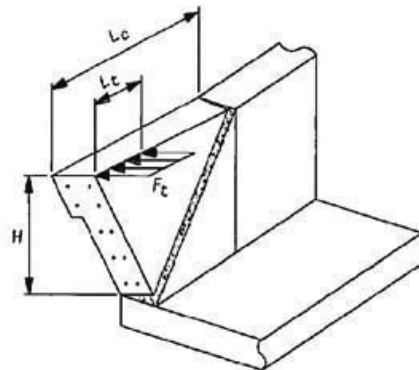

$L_c$ = Critical length of yield line failure pattern  
 $L_t$ = Longitudinal length of distribution of impact force  
 $F_t$ = Transverse impact force

Fig.CA13.3.1- 1 AASHTO LRFD 2012

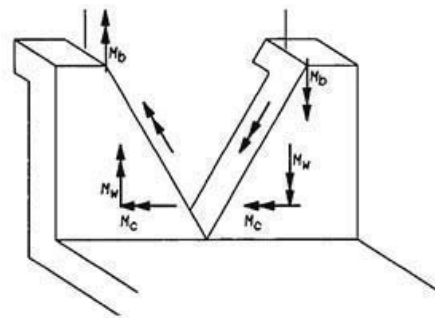

$M_c$  = Flexural resistance of the traffic barrier about its vertical axis.  
 RESISTANCE PROVIDED BY TRANSVERSE REINFORCEMENT

$M_b, M_w$ = Flexural resistance of the traffic barrier about an axis parallel to the longitudinal axis of the bridge  
 RESISTANCE PROVIDED BY LONGITUDINAL REINFORCEMENT



## B. Development Length and Reinforcement Splices



Recall:

$N_{tr,barrier} = 6$  Traffic barrier transverse reinforcement bar size. (GFRP bent bars)

$N_{lg,barrier} = 6$  Traffic barrier longitudinal reinforcement bar size. (GFRP straight bars)

$N_{sh,barrier} = 4$  Traffic barrier shear reinforcement bar size. (GFRP U bent bars)

The reinforcement has been selected in chapter 1.04 - section B2

Transverse GFRP reinforcement ratio producing balanced condition [AASHTO GFRP 2009, 2.7.4.2-2]:

$$\rho_{fbtr} := 0.85 \cdot \beta_{1,super} \cdot \frac{f_{c,super} \cdot E_{fNo_{tr,barrier}} \cdot \epsilon_{cu}}{f_{fd,tr,barrier} \cdot (E_{fNo_{tr,barrier}} \cdot \epsilon_{cu} + f_{fd,tr,barrier})} = 0.9\%$$

Longitudinal GFRP reinforcement ratio producing balanced condition [AASHTO GFRP 2009, 2.7.4.2-2]:

$$\rho_{fblg} := 0.85 \cdot \beta_{1,super} \cdot \frac{f_{c,super} \cdot E_{fNo_{lg,barrier}} \cdot \epsilon_{cu}}{f_{fd,lg,barrier} \cdot (E_{fNo_{lg,barrier}} \cdot \epsilon_{cu} + f_{fd,lg,barrier})} = 0.9\%$$

Transverse GFRP reinforcement ratio [AASHTO GFRP 2009, 2.7.4.2]

$$\rho_{ftr} := 1.2 \cdot \rho_{fbtr} = 0.011$$

Longitudinal GFRP reinforcement ratio [AASHTO GFRP 2009, 2.7.4.2]

$$\rho_{flg} := 1.2 \cdot \rho_{fblg} = 0.011$$

Longitudinal bar location modification factor [AASHTO GFRP 2009, 2.12.2.2.1]

$$\alpha_{lg} := 1$$

Top transverse bar location modification factor [AASHTO GFRP 2009, 2.12.2.2.1]

$$\alpha_{tr\_top} := 1.5$$

Bottom transverse bar location modification factor [AASHTO GFRP 2009, 2.12.2.2.1]

$$\alpha_{tr\_bottom} := 1$$

Effective tensile strength of transverse reinforcement [AASHTO GFRP 2009, 2.9.3.1-1]:

$$f_{ftr} := \min \left[ \sqrt{\frac{(E_{fNo_{tr,barrier}} \cdot \epsilon_{cu})^2}{4} + \frac{0.85 \cdot \beta_{1,super} \cdot f_{c,super} \cdot E_{fNo_{tr,barrier}} \cdot \epsilon_{cu}}{\rho_{ftr}} - 0.5 \cdot (E_{fNo_{tr,barrier}} \cdot \epsilon_{cu})}, f_{fd,tr,barrier} \right]$$

Effective tensile strength of longitudinal reinforcement [AASHTO GFRP 2009, 2.9.3.1-1]:

$$f_{flg} := \min \left[ \sqrt{\frac{(E_{fNo_{lg,barrier}} \cdot \epsilon_{cu})^2}{4} + \frac{0.85 \cdot \beta_{1,super} \cdot f_{c,super} \cdot E_{fNo_{lg,barrier}} \cdot \epsilon_{cu}}{\rho_{flg}} - 0.5 \cdot (E_{fNo_{lg,barrier}} \cdot \epsilon_{cu})}, f_{fd,lg,barrier} \right]$$

$$C_{ctr} := c_c + 0.5 \text{ diam}_{No_{tr,barrier}} = 1.9 \text{ in} \quad [\text{AASHTO GFRP 2009, 2.12.2.1}]$$

$$C_{clg} := c_c + 0.5 \text{ diam}_{No_{lg,barrier}} = 1.9 \text{ in}$$

$$C_{csh} := c_c + 0.5 \cdot \text{diam}_{No_{sh.barrier}} = 1.8 \cdot \text{in}$$

Transverse top reinforcement development length [AASHTO GFRP 2009, 2.12.2.1-1]:

$$l_{D.tr} := \frac{\alpha_{tr\_top} \cdot \frac{f_{ftr}}{\sqrt{f_{c.super} \cdot \psi_i}} - 340}{13.6 + \frac{C_{ctr}}{\text{diam}_{No_{tr.barrier}}}} \cdot \text{diam}_{No_{tr.barrier}} = 56.1 \cdot \text{in}$$

Transverse bottom reinforcement development length [AASHTO GFRP 2009, 2.12.2.1-1]:

$$l_{C.tr} := \frac{\alpha_{tr\_bottom} \cdot \frac{f_{ftr}}{\sqrt{f_{c.super} \cdot \psi_i}} - 340}{13.6 + \frac{C_{ctr}}{\text{diam}_{No_{tr.barrier}}}} \cdot \text{diam}_{No_{tr.barrier}} = 32 \cdot \text{in}$$

Longitudinal reinforcement development length [AASHTO GFRP 2009, 2.12.2.1-1]:

$$l_{d\_lg} := \frac{\alpha_{lg} \cdot \frac{f_{flg}}{\sqrt{f_{c.super} \cdot \psi_i}} - 340}{13.6 + \frac{C_{ctr}}{\text{diam}_{No_{lg.barrier}}}} \cdot \text{diam}_{No_{lg.barrier}} = 32 \cdot \text{in}$$

Longitudinal reinforcement splice length [AASHTO GFRP 2009, 2.12.4]:

$$l_{sp\_lg} := 1.3 \cdot l_{d\_lg} = 42 \cdot \text{in}$$

Tail length of shear reinforcement [ACI 318-14]:

$$l_{tail} := 12 \cdot \text{diam}_{No_{sh.barrier}} = 6 \cdot \text{in}$$



## C. Design Loads



Height of the vehicle center of gravity above bridge deck [AASHTO LRFD 2014, A130.7.2]  $G_v := 27 \text{in}$

Weight of the vehicle corresponding to the required test level [AASHTO LRFD 2014, A13.7.2]  $W_v := 4.5 \text{kip}$

Out-to-out wheel spacing on one axle [AASHTO LRFD 2014, A13.7.2]  $B := 6.5 \text{in}$

Transverse vehicle impact forces from TL-1 to TL-6 distributed over 1ft length at height H(e) above the bridge deck [AASHTO LRFD 2014, A13.7.2]  $F_{tr} := (13.5 \text{kip} \ 27 \text{kip} \ 54 \text{kip} \ 54 \text{kip} \ 124 \text{kip} \ 175 \text{kip})$

Transverse vehicle impact force for the selected TL distributed over 1ft length at height H(e) above the  $F_{tr1,TL} = 54 \cdot \text{kip}$



bridge deck [AASHTO LRFD 2014, A13.7.2]

Effective height of the vehicle rollover force  
[AASHTO LRFD 2014, A13.2-1]

$$H_e := G_v - 12 \cdot W_v \cdot \frac{B}{(2 \cdot F_{tr1, TL})} = 23.8 \cdot \text{in}$$

Longitudinal length of distribution of impact force from  
TL-1 to TL-6 along the railing located at height H(e)  
above the deck [AASHTO LRFD 2014, A13.2]

$$L_t := (4\text{ft} \quad 4\text{ft} \quad 4\text{ft} \quad 3.5\text{ft} \quad 8\text{ft} \quad 8\text{ft})$$

Longitudinal length of distribution of impact force for  
the selected TL along the railing located at height H(e)  
above the deck [AASHTO LRFD 2014, A13.2]

$$L_{t1, TL} = 3.5 \cdot \text{ft}$$

Ultimate Bending moment on longitudinal direction  
acting on the length of distribution of the impact force

$$M_u := \frac{\frac{F_{tr1, TL}}{L_{t1, TL}} \cdot (L_{t1, TL})^2}{10} = 19 \cdot \text{kip} \cdot \text{ft}$$

Ultimate Shear force on longitudinal direction acting on  
the length of distribution of the impact force

$$V_u := \frac{\frac{F_{tr1, TL}}{L_{t1, TL}} \cdot L_{t1, TL}}{2} = 27 \cdot \text{kip}$$

Note: Hybrid fixed-pinned end connection has been selected to account for the flexural  
resistance of the barrier about its vertical axis [Matta and Nanni, 2009]



## D. Corner Joint Verification



Bar diameter used for primary deck reinforcement

$$\text{diam}_{No_{pr.slab}} = 1.25 \cdot \text{in}$$

Bar diameter used for secondary deck reinforcement

$$\text{diam}_{No_{sec.slab}} = 0.75 \cdot \text{in}$$

Clear horizontal distance between two primary rebars

$$b_{tr} := 21 \cdot \text{in}$$

Clear vertical distance between two primary rebars

$$h_{tr} := t_{slab} - 2 \cdot \text{diam}_{No_{pr.slab}} - 2 \cdot \text{diam}_{No_{sec.slab}} - 2c_c = 11 \cdot \text{in}$$

Cracking angle

$$\alpha_{cr} := \text{atan}\left(\frac{h_{tr}}{b_{tr}}\right) = 27.6 \cdot \text{deg}$$

Length of diagonal crack in corner joint  
[AASHTO GFRP 2009, CA3.1.2]

$$l_{dc} := \frac{h_{tr}}{\sin(\alpha_{cr})} = 23.7 \cdot \text{in}$$

Modulus of rupture of concrete  
[AASHTO LRFD 2014]

$$f_{rupture} := 0.3 \cdot \sqrt{f_{c.super} \cdot \text{ksi}} = 0.6 \cdot \text{ksi}$$

Tensile strength per unit width of diagonal  
crack [AASHTO GFRP 2009, CA3.1.2]

$$T_b := (8 \cdot f_{rupture} \cdot l_{dc}) \cdot \text{in} = 120.7 \cdot \text{kip}$$

Resultant compressive force in post section [AASHTO GFRP 2009, CA3.1.2]	$C_p := T_b \cdot \cos(\alpha_{cr}) = 106.9 \cdot \text{kip}$
Deck moment at connection section	$M_d(F_{np\_guess}) := F_{np\_guess} \cdot \left( H_e + \frac{t_{slab}}{2} \right)$
Compression force at deck and post connection section for assumed nominal strength of post-deck connection	$C_d(F_{np\_guess}) := \frac{M_d(F_{np\_guess})}{t_{slab} - 1.5 \cdot c_c}$
Assume the reinforcement ultimate load capacity as initial value for the nominal strength of post-deck connection and iterate until convergence is achieved	$F_{np\_guess} := F_{futr.barrier} = 48.3 \cdot \text{kip}$
Reinforcement nominal strength per unit width required for convergence:	
	$f(F_{np\_guess}) := C_d(F_{np\_guess}) - T_b \cdot \sin(\alpha_{cr}) - 0.5F_{np\_guess}$
	$F_{np} := \text{root}(f(F_{np\_guess}), F_{np\_guess}) = 35.5 \cdot \text{kip}$
Note: As moment redistribution cannot be accounted in the analysis of indeterminate GFRP-RC structures, a methodology that imposes equilibrium and compatibility conditions is implemented in lieu of yield line analysis. Convergence is achieved for tensile load capacity using an iterative procedure. [Matta and Nanni, 2009]	
Area of single transverse reinforcement bar	$\text{area}_{No_{tr.barrier}} = 0.44 \cdot \text{in}^2$
Number of bars per ft	$\text{Bars} := \frac{12\text{in}}{S_{sec.slt.eb}} = 2$
Equivalent area of transverse reinforcement in 1ft	$A_{tr\_1ft} := \text{area}_{No_{tr.barrier}} \cdot \text{Bars} = 0.9 \cdot \text{in}^2$
Equivalent reinforcement nominal strength for convergence in 1ft	$F_{np\_1ft} := F_{np} \cdot \text{Bars} = 70.9 \cdot \text{kip}$
Equivalent design tensile load capacity of transverse reinforcement in 1ft considering reduction for service environment [AASHTO GFRP 2009, 2.6.1.2]	$F_{fdtr.barrier} \cdot \text{Bars} = 67.7 \cdot \text{kip}$
Strength reduction factor for diagonal tension [Matta and Nanni, 2009]	$\Phi_{dt} := 0.85$
Check_Corner_Resistance :=	$\begin{cases} \text{"CORNER RESISTANCE NOT VERIFIED"} & \text{if } F_{np\_1ft} \cdot \Phi_{dt} > F_{fdtr.barrier} \cdot \text{Bars} \\ \text{"CORNER RESISTANCE NOT VERIFIED"} & \text{if } F_{tr\_1,TL} > \Phi_{dt} \cdot F_{np\_1ft} \\ \text{"CORNER RESISTANCE VERIFIED"} & \text{otherwise} \end{cases}$
Test Level [AASHTO LRFD 2014, 13.7.2]	$TL = 4$
Transverse vehicle impact force [AASHTO LRFD 2014, A13.7.2]	$F_{tr\_1,TL} = 54 \cdot \text{kip}$
Factored nominal load capacity of reinforcement for convergence	$F_{np\_1ft} \cdot \Phi_{dt} = 60.3 \cdot \text{kip}$

Factored load capacity of reinforcement considering reduction for service environment [AASHTO GFRP 2009, 2.6.1.2]

$$F_{fdtr.barrier} \cdot Bars = 67.7 \cdot kip$$

Check\_Corner\_Resistance = "CORNER RESISTANCE VERIFIED"



## E. Flexural Verification

### E1. Limits for Reinforcement



Distance from extreme compression fiber to centroid of tension reinforcement: [AASHTO GFRP 2009, 2.9.3.3]

$$d_{fl} := 11 \text{ in} - c_c - \text{diam}_{No_{tr.barrier}} - \frac{\text{diam}_{No_{lg.barrier}}}{2} = 8.4 \text{ in}$$

Width of cross section [AASHTO GFRP 2009, 2.9.3.3]

$$b_{fl} := 32 \text{ in}$$

Design tensile strength of GFRP bars considering reductions for service environment [AASHTO GFRP 2009, 2.9.3.3]

$$f_{fd.lg.barrier} = 76.6 \cdot ksi$$

Minimum requirement for flexural tensile reinforcement [AASHTO GFRP 2009, 2.9.3.3]:

$$A_{f\_min} := \max \left[ 0.16 \sqrt{f_{c.super} \cdot ksi} \cdot \frac{b_{fl} \cdot \text{diam}_{No_{lg.barrier}}}{f_{fd.lg.barrier}}, \left( 0.33 \cdot \frac{b_{fl} \cdot d_{fl}}{f_{fd.lg.barrier}} \right) \frac{kip}{in^2} \right] = 1.2 \cdot in^2$$

Area of reinforcement provided

$$A_{f\_long} := 4 \cdot \text{area}_{No_{lg.barrier}} = 1.8 \cdot in^2$$

Minimum requirement for flexural tensile reinforcement [AASHTO GFRP 2009, 2.9.3.3]

$$A_{f\_min} = 1.2 \cdot in^2$$

$$\text{check\_flexural\_minimum\_reinforcement} := \begin{cases} \text{"VERIFIED"} & \text{if } A_{f\_long} \geq A_{f\_min} \\ \text{"NOT VERIFIED"} & \text{otherwise} \end{cases}$$

check\_flexural\_minimum\_reinforcement = "VERIFIED"



### E2. Flexural Strength



Distance from extreme compression fiber to centroid of tension reinforcement [AASHTO GFRP 2009, 2.9.3.3]

$$d_{fl} = 8.4 \text{ in}$$

Effective strength in GFRP reinforcement [AASHTO GFRP 2009, 2.9.3.1-1]

$$f_{flg} = 69.1 \cdot ksi$$

Tensile strength of longitudinal reinforcement for product certification as reported by GFRP manufacturers [AASHTO GFRP 2009, 2.6.1.2]

$$f_{fd.lg.barrier} = 76.6 \cdot ksi$$

Area of reinforcement provided

$$A_{f\_long} = 1.8 \cdot in^2$$

Depth of equivalent rectangular stress block [AASHTO GFRP 2009, 2.9.3.2.2-3]:

$$a_{fl} := \frac{\text{area}_{\text{No.lg.barrier}} \cdot f_{flg}}{0.85 \cdot f_{c.super} \cdot b_{fl}} = 0.2 \cdot \text{in}$$

Concrete ultimate strain [AASHTO GFRP 2009, 2.9.2.1]

$$\epsilon_{cu} = 0.003$$

Design strain of longitudinal reinforcement considering reduction for service environment [AASHTO GFRP 2009, 2.6.1.2]

$$\epsilon_{fd\text{No.lg.barrier}} = 0.011$$

GFRP reinforcement ratio producing balanced condition [AASHTO GFRP 2009, 2.7.4.2-2]

$$\rho_{fb1g} = 0.009$$

GFRP reinforcement ratio [AASHTO GFRP 2009, 2.7.4.2]

$$\rho_{flg} = 0.011$$

Distance from extreme compression fiber to neutral axis at balanced condition [AASHTO GFRP 2009, 2.9.3.2.2-4]

$$c_b := \left( \frac{\epsilon_{cu}}{\epsilon_{cu} + \epsilon_{fd\text{No.lg.barrier}}} \right) d_{fl} = 1.8 \cdot \text{in}$$

$$M_n := \begin{cases} \left[ A_{f\_long} \cdot f_{flg} \cdot \left( d_{fl} - \frac{a_{fl}}{2} \right) \right] & \text{if } \rho_{flg} > \rho_{fb1g} \\ \left[ A_{f\_long} \cdot f_{fd.lg.barrier} \cdot \left( d_{fl} - \frac{\beta_{1.super} \cdot c_b}{2} \right) \right] & \text{if } \rho_{flg} \leq \rho_{fb1g} \end{cases}$$

Nominal flexural resistance [AASHTO GFRP 2009, 2.9.3.2.2-1, 2.9.3.2.2-3]

$$M_n = 84 \cdot \text{kip} \cdot \text{ft}$$

$$\Phi_{fl} := \begin{cases} 0.55 & \text{if } \rho_{flg} \leq \rho_{fb1g} \\ \left( 0.3 + 0.25 \cdot \frac{\rho_{flg}}{\rho_{fb1g}} \right) & \text{if } \rho_{fb1g} < \rho_{flg} < 1.4 \cdot \rho_{fb1g} \\ 0.65 & \text{if } \rho_{flg} \geq 1.4 \cdot \rho_{fb1g} \end{cases}$$

Resistance factor for flexure [AASHTO GFRP 2009, 2.7.4.2-1]

$$\Phi_{fl} = 0.6$$

Factored flexural resistance [AASHTO GFRP 2009, 2.9.3.2.1-1]

$$M_r := \Phi_{fl} \cdot M_n = 50 \cdot \text{kip} \cdot \text{ft}$$

Ultimate bending moment due to impact force on longitudinal direction

$$M_u = 19 \cdot \text{kip} \cdot \text{ft}$$

$$\text{check\_flexural\_resistance} := \left( \begin{array}{l} \text{"VERIFIED"} \text{ if } M_r \geq M_u \\ \text{"NOT VERIFIED"} \text{ otherwise} \end{array} \right)$$

check\_flexural\_resistance = "VERIFIED"



## F. Shear Verification

### F1. Concrete shear strength

▾

Width of the web [AASHTO GFRP 2009, 2.10.2.2.2]  $b_w := b_{fl} = 32 \cdot \text{in}$

GFRP reinforcement ratio factored flexural resistance [AASHTO GFRP 2009, 2.7.4.2]  $\rho_{flg} = 1.1\%$

Concrete modulus of elasticity [FDOT LRFD design example#2]  $E_c := \Phi_{limerock} \cdot 1820 \sqrt{f_{c.super} \cdot \text{ksi}} = 3.5 \times 10^3 \cdot \text{ksi}$

Modulus of elasticity of longitudinal GFRP reinforcement  $E_{fNo1g.barrier} = 7.2 \times 10^3 \cdot \text{ksi}$

Modular ratio  $n_f := \frac{E_{fNo1g.barrier}}{E_c} = 2.1$

Ratio of depth of neutral axis to reinforcement depth [AASHTO GFRP 2009, 2.7.3-4]  $k := \sqrt{2 \cdot \rho_{flg} \cdot n_f + (\rho_{flg} \cdot n_f)^2} - \rho_{flg} \cdot n_f = 0.2$

Distance from extreme compression fiber to centroid of tension reinforcement [AASHTO GFRP 2009, 2.9.3.3]  $d_{fl} = 8.4 \cdot \text{in}$

Distance from extreme compression fiber to neutral axis [AASHTO GFRP 2009, 2.10.3.2]  $C_{fl} := k \cdot d_{fl} = 1.6 \cdot \text{in}$

Nominal shear strength provided by the concrete [AASHTO GFRP 2009, 2.10.3.2.1-1]:

$$V_c := \max\left(0.16 \sqrt{f_{c.super} \cdot \text{ksi}} \cdot b_w \cdot C_{fl}, 0.32 \sqrt{f_{c.super} \cdot \text{ksi}} \cdot b_{fl} \cdot C_{fl}\right) = 34.8 \cdot \text{kip}$$

Resistance factor for shear  $\Phi_{sh} := 0.75$

Factored shear strength provided by the concrete [AASHTO GFRP 2009, 2.10.2.1-1]  $\Phi_{sh} \cdot V_c = 26.1 \cdot \text{kip}$

Ultimate shear force due to impact force on longitudinal direction  $V_u = 27 \cdot \text{kip}$

check\_concrete\_shear\_resistance :=  $\begin{cases} \text{"VERIFIED: SHEAR REINFORCEMENT NOT REQUIRED"} & \text{if } \Phi_{sh} \cdot V_c > V_u \\ \text{"NOT VERIFIED: SHEAR REINFORCEMENT REQUIRED"} & \text{otherwise} \end{cases}$

**check\_concrete\_shear\_resistance = "NOT VERIFIED: SHEAR REINFORCEMENT REQUIRED"**

Note: It is legitimate to approximate the parapet behavior to one way cantilivered slab. Therefore Eq.2.10.2.2-1 is not applied.

▴

## F2. Shear reinforcement strength



Required nominal shear resistance provided by the GFRP shear reinforcement  
[AASHTO GFRP 2009, 2.10.2.1-1, 2.10.3.1-1]

$$V_{f\_required} := \frac{V_u}{\Phi_{sh}} - V_c = 1.2 \cdot \text{kip}$$

Diameter of shear GFRP reinforcement

$$\text{diam}_{\text{No}_{sh.barrier}} = 0.5 \cdot \text{in}$$

Area of shear GFRP reinforcement

$$\text{area}_{\text{No}_{sh.barrier}} = 0.2 \cdot \text{in}^2$$

Number of stirrups (1 shear leg each)

$$\text{stirr} := 3$$

Internal radius of the shear bent GFRP bar

$$r_{b\text{No}_{sh.barrier}} = 2.1 \cdot \text{in}$$

Distance from extreme compression fiber to centroid of tension reinforcement  
[AASHTO GFRP 2009, 2.9.3.3]

$$d_{fl} = 8.4 \cdot \text{in}$$

Design strength of shear reinforcement considering reduction for service environment  
[AASHTO GFRP 2009, 2.6.1.2]

$$f_{fd.sh.barrier} = 87.9 \cdot \text{ksi}$$

Strength of the bent portion of a GFRP bar [AASHTO GFRP 2009, 2.10.3.2.2-3]

$$f_{fb} := \min \left[ \left( 0.05 \cdot \frac{r_{b\text{No}_{sh.barrier}}}{\text{diam}_{\text{No}_{sh.barrier}}} + 0.3 \right) \cdot f_{fd.sh.barrier}, f_{fd.sh.barrier} \right] = 45 \cdot \text{ksi}$$

Modulus of elasticity of shear GFRP reinforcement

$$E_{f\text{No}_{sh.barrier}} = 7.1 \times 10^3 \cdot \text{ksi}$$

Design tensile strength for shear  
[AASHTO GFRP 2009, 2.10.3.2.2-2]

$$f_{fv} := \min \left( 0.004 \cdot E_{f\text{No}_{sh.barrier}}, f_{fb} \right) = 28.4 \cdot \text{ksi}$$

Maximum spacing of shear reinforcement  
[AASHTO GFRP 2009, 2.10.3.2.2.1]

$$s_{sh\_max} := \frac{\text{stirr area}_{\text{No}_{sh.barrier}} \cdot f_{fv} \cdot d_{fl}}{V_{f\_required}} = 115.1 \cdot \text{in}$$

$$s_{sh} := \begin{cases} S_{sec.slt.slabs} & \text{if } S_{sec.slt.slabs} < s_{sh\_max} < 2S_{sec.slt.slabs} \\ (2 \cdot S_{sec.slt.slabs}) & \text{if } 2S_{sec.slt.slabs} < s_{sh\_max} < 3S_{sec.slt.slabs} \\ (3 \cdot S_{sec.slt.slabs}) & \text{if } 3S_{sec.slt.slabs} < s_{sh\_max} < 4S_{sec.slt.slabs} \\ ((4 \cdot S_{sec.slt.slabs})) & \text{otherwise} \end{cases}$$

"SHEAR REINFORCEMENT NOT REQUIRED" if  $\Phi_{sh} \cdot V_c > V_u$

"INCREASE SHEAR REINFORCEMENT DIAMETER" if  $S_{sec.slt.slabs} > s_{sh\_max} > 0$

Required nominal shear resistance provided by the GFRP shear reinforcement  
[AASHTO GFRP 2009, 2.10.2.1-1, 2.10.3.1-1]

$$V_{f\_required} = 1.2 \cdot kip$$

Design spacing of shear reinforcement [AASHTO GFRP 2009, 2.10.3.2.2.1]

$$s_{sh} = 32 \cdot in$$

Note: Tie shear reinforcement to transverse reinforcement



**G. Summary of Provided Reinforcement and Detailing**

Transverse reinforcement

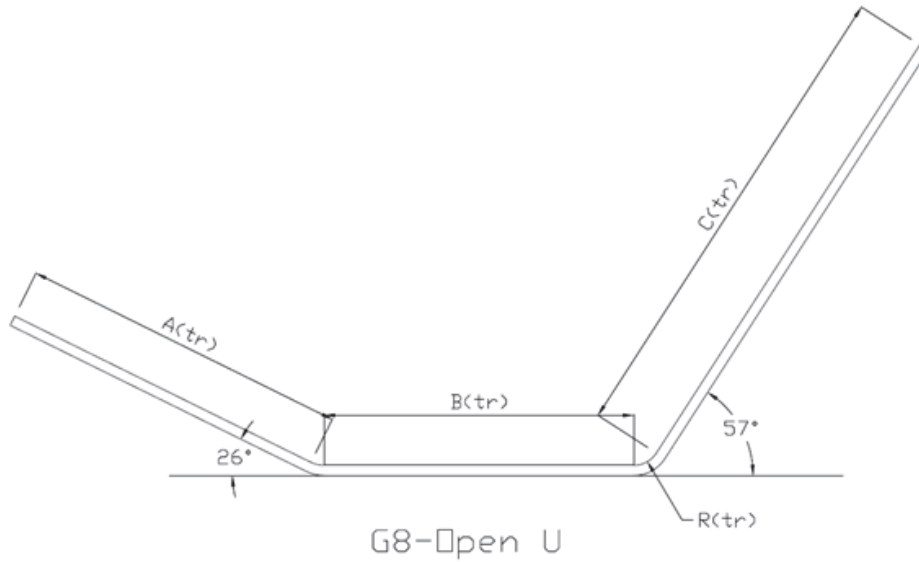

$A_{tr} := 24\text{in}$

$B_{tr} := 22\text{in}$

Bar development length

$l_{C.tr} = 32\text{-in}$

GFRP bar number

$N_{o.tr.barrier} = 6$

Internal radius of GFRP bar bent

$r_{bN_{o.tr.barrier}} = 2.3\text{-in}$

Bar spacing in longitudinal direction center to center

$S_{sec.sl.t.eb} = 6\text{-in}$

Total linear length

$$L_{1tot} := A_{tr} + B_{tr} + l_{C.tr} + \frac{11}{30.4} \cdot 2 \cdot \pi \cdot r_{bN_{o.tr.barrier}} + \frac{32}{45.4} \cdot 2 \cdot \pi \cdot r_{bN_{o.tr.barrier}} = 82\text{-in}$$



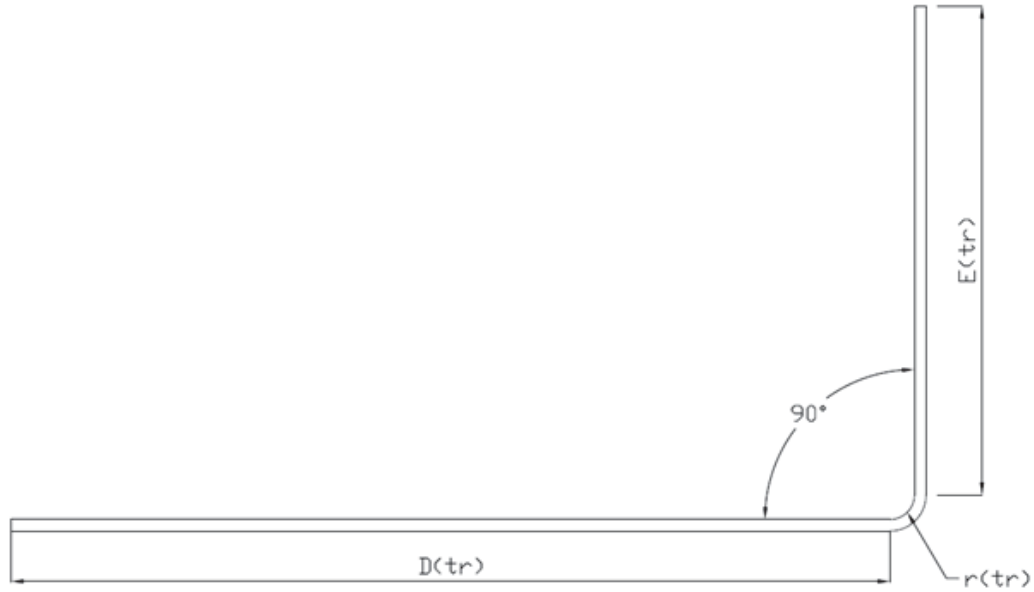

G1-90 Deg Bent

$E_{tr} := 32in$

Bar development length

$l_{D.tr} = 56 \cdot in$

GFRP bar number

$N_{0_{tr.barrier}} = 6$

Internal radius of GFRP bar bent

$r_{b_{No_{tr.barrier}}} = 2.3 \cdot in$

Bar spacing in longitudinal direction center to center

$S_{sec.slt.eb} = 6 \cdot in$

Total linear length

$L_{2tot} := E_{tr} + l_{D.tr} + \frac{1}{4} \cdot 2 \cdot \pi \cdot r_{b_{No_{tr.barrier}}} = 92 \cdot in$



**Longitudinal reinforcement**



0 Deg Bent

GFRP Bar number

$$N_{lg,barrier} = 6$$

Splice length

$$l_{sp\_lg} = 42\text{-in}$$



**Shear reinforcement**

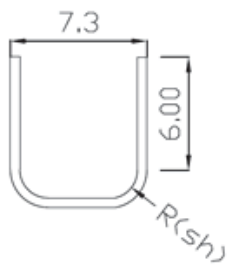

G7-U/C 1

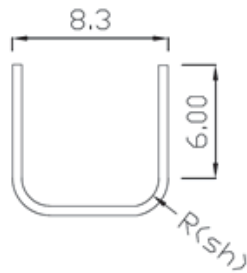

G7-U/C 2

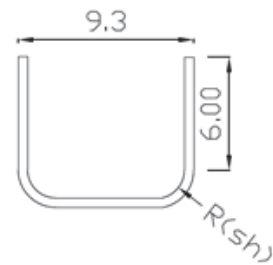

G7-U/C 3

GFRP Bar number

$$N_{sh,barrier} = 4$$

Spacing

$$s_{sh} = 32\text{-in}$$

Note: when shear reinforcement is not required, place G7-U/C1 for constructability



**Reinforcement layout**



SECTION THRU NEW JERSEY SHAPE RAILING (FDOT 2014)  
TL-3 AND TL-4 (SHEAR REINFORCEMENT REQUIRED)

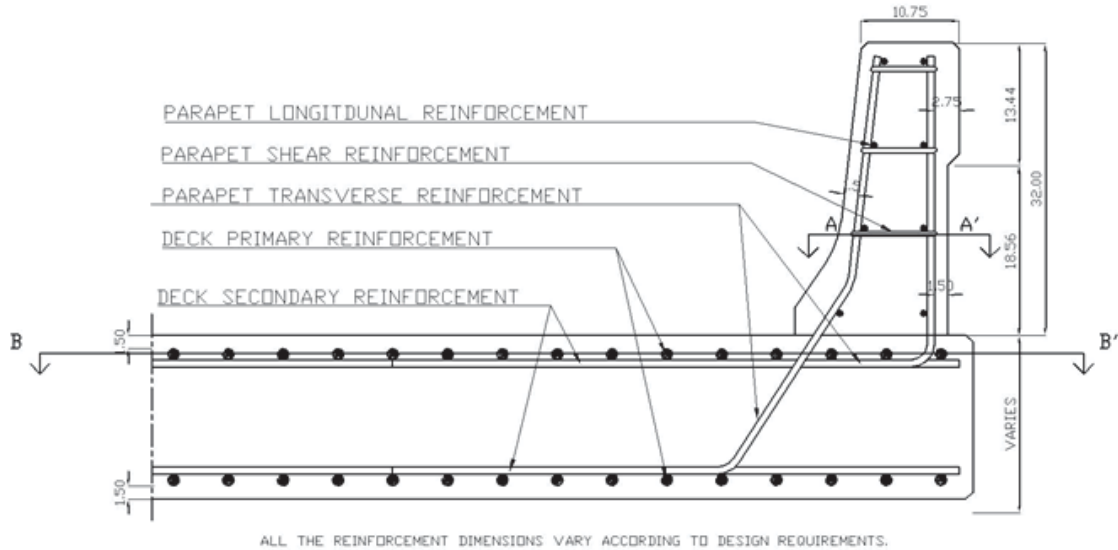

SECTION A - A'

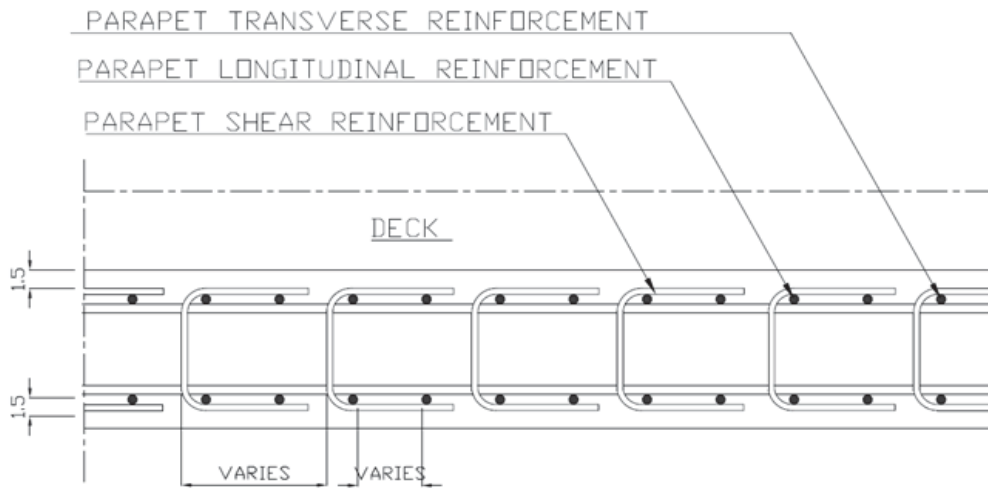

SECTION B - B'

PARAPET TRANSVERSE REINFORCEMENT

DECK PRIMARY REINFORCEMENT

DECK SECONDARY REINFORCEMENT

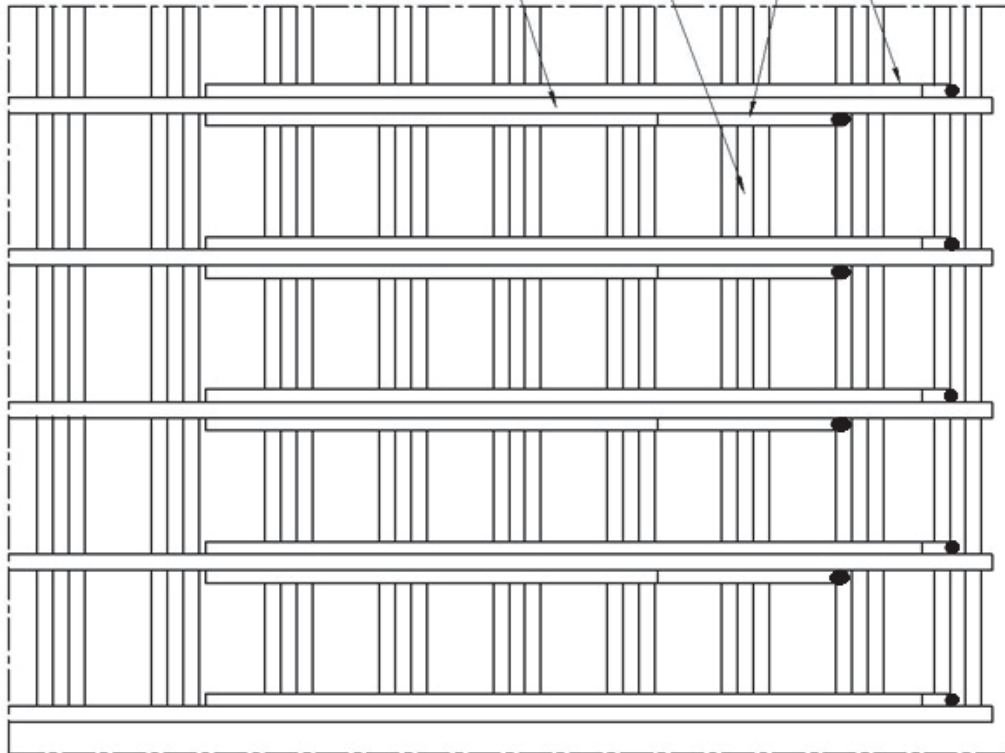

ALL THE REINFORCEMENT DIMENSIONS VARY ACCORDING TO DESIGN REQUIREMENTS.





## SUPERSTRUCTURE DESIGN

### Expansion Joint Design

---

#### References (links to other Mathcad files)

 Reference:L:\LRFD\_Design\_Example\_#2A thesis\2.03.Edge\_Beam\_Design\_Loads.xmcd(R)

#### Description

This section provides the design of the bridge expansion joints.

<b>Page</b>	<b>Contents</b>
109	LRFD Criteria
109	FDOT Criteria
110	A. Input Variables
	A1. Bridge Geometry
	A2. Temperature Movement [SDG 2015, 6.3]
	A3. Expansion Joints [SDG 2015, 6.4]
	A4. Movement [SDG 2015, 6.4.2]
113	B. Expansion Joint Design
	B1. Creep, Shrinkage and Temperature Design [SDG 2015, 6.4.2]
	B2. Temperature Change only @ 115% Design [SDG 2015, 6.4.2]
	B3. Temperature Adjustment for Field Placement of Joint
115	C. Design Summary

**LRFD Criteria****Uniform Temperature [SDG 2015, 3.12.2]**

Superseded by SDG 2.7.2 and SDG 6.4.

**Shrinkage and Creep [SDG 2015, 5.4.2.3]****Movement and Loads - General [SDG 2015, 14.4.1]****Bridge Joints [14.5]****FDOT Criteria****Uniform Temperature - Joints and Bearings [SDG 2015, 2.7.2]**

Delete LRFD [3.12.2] and substitute in lieu thereof SDG Chapter 6.

**Expansion Joints [SDG 6.4]**

## A. Input Variables

### A1. Bridge Geometry

Overall bridge length.....  $L_{\text{bridge}} = 105 \text{ ft}$

Bridge design span length..  $L_{\text{span}} = 35 \text{ ft}$

Skew angle.....  $\text{Skew} = -30\text{-deg}$

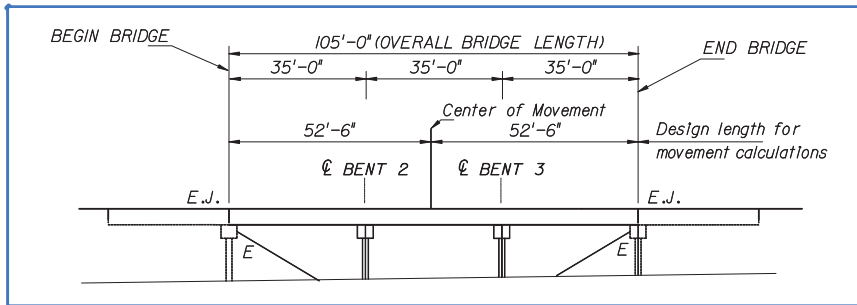

Design length for movement  $L_{\text{design}} := 52.5 \cdot \text{ft}$

### A2. Temperature Movement [SDG 2015, 6.3]

Structural Material of Superstructure	Temperature (Degrees Fahrenheit)			
	Mean	High	Low	Range
Concrete Only	70	95	45	50
Concrete Deck on Steel Girder	70	110	30	80
Steel Only	70	120	30	90

The temperature values for "Concrete Only" in the preceding table apply to this example.

Temperature mean....  $t_{\text{mean}} = 70 \cdot ^\circ\text{F}$

Temperature high.....  $t_{\text{high}} = 95 \cdot ^\circ\text{F}$

Temperature low.....  $t_{\text{low}} = 45 \cdot ^\circ\text{F}$

Temperature rise.....  $\Delta t_{\text{rise}} := t_{\text{high}} - t_{\text{mean}} \qquad \Delta t_{\text{rise}} = 25 \cdot ^\circ\text{F}$

Temperature fall.....  $\Delta t_{\text{fall}} := t_{\text{mean}} - t_{\text{low}} \qquad \Delta t_{\text{fall}} = 25 \cdot ^\circ\text{F}$

Coefficient of thermal expansion  
**[AASHTO LRFD 2014, 5.4.2.2]** for  
 normal weight concrete.....

$$\alpha_t = 6 \times 10^{-6} \cdot \frac{1}{^\circ\text{F}}$$

**A3. Expansion Joints [SDG 6.4]**

Joint Type	Maximum Joint Width *
Poured Rubber	3/4"
Silicone Seal	2"
Strip Seal	3"
Modular Joint	Unlimited
Finger Joint	Unlimited

\*Joints in sidewalks must meet all requirements of Americans with Disabilities Act.

For new construction, use only the joint types listed in the preceding table. A typical joint for most flat slab bridges is the silicone seal.

Maximum joint width.....  $W_{max} := 2 \cdot \text{in}$

Minimum joint width at 70° F.....  $W_{min} := \frac{5}{8} \cdot \text{in}$

Proposed joint width at 70° F.....  $W := 1 \cdot \text{in}$

**A4. Movement [SDG 2015, 6.4.2]**

**Temperature**

The movement along the beam due to temperature should be resolved along the axis of the expansion joint or skew.

Displacements normal to skew at top of bents

Temperature rise.....  $\Delta z_{TempR} := \alpha_t \cdot \Delta t_{rise} \cdot \cos(|Skew|) \cdot L_{design}$        $\Delta z_{TempR} = 0.08 \cdot \text{in}$

Temperature Fall.....  $\Delta z_{TempF} := \alpha_t \cdot \Delta t_{fall} \cdot \cos(|Skew|) \cdot L_{design}$        $\Delta z_{TempF} = 0.08 \cdot \text{in}$

Displacements parallel to skew at top of bents

Temperature rise.....  $\Delta x_{TempR} := \alpha_t \cdot \Delta t_{rise} \cdot \sin(|Skew|) \cdot L_{design}$        $\Delta x_{TempR} = 0.05 \cdot \text{in}$

Temperature Fall.....  $\Delta x_{TempF} := \alpha_t \cdot \Delta t_{fall} \cdot (\sin(|Skew|) \cdot L_{design})$        $\Delta x_{TempF} = 0.05 \cdot \text{in}$

For silicone seals, displacements parallel to the skew are not significant in most joint designs. For this example, these displacements are ignored.



**Creep and Shrinkage**

The following assumptions are used in this design example:

- Creep of the concrete for expansion joint design is ignored.
- Shrinkage of the concrete for the flat slab is cast-in-place flat slab will be taken as per AASHTO LRFD 2014, 5.4.3.2.1 as the total shrinkage after one year of drying.

Creep strain.....  $\epsilon_{CR} := 0.$

Shrinkage strain.....  $\epsilon_{SH} := 0.0005$

Strain due to creep and shrinkage

$$\epsilon_{CS} := \epsilon_{CR} + \epsilon_{SH} \quad \epsilon_{CS} = 0.00050$$

The movement along the beam due to creep and shrinkage should be resolved along the axis of the expansion joint or skew.

Displacements normal to skew at top of bents.....  $\Delta z_{CS} := \epsilon_{CS} \cdot \cos(|Skew|) \cdot L_{design}$   
 $\Delta z_{CS} = 0.27 \cdot \text{in}$

Displacements parallel to skew at top of bents.....  $\Delta x_{CS} := \epsilon_{CS} \cdot \sin(|Skew|) \cdot L_{design}$   
 $\Delta x_{CS} = 0.16 \cdot \text{in}$

For silicone seals, displacements parallel to the skew are not significant in most joint designs. For this example, these displacements are ignored.

## B. Expansion Joint Design

For conventional concrete structures, the movement is based on the greater of two cases:

- Movement from the combination of temperature fall, creep, and shrinkage
- Movement from factored effects of temperature

### B1. Movement from Creep, Shrinkage and Temperature [SDG 2015, 6.4.2]

The combination of creep, shrinkage, and temperature fall tends to "open" the expansion joint.

Movement from the combination of temperature fall, creep, and shrinkage.....  $\Delta z_{\text{Temperature.Fall}} = \Delta z_{\text{temperature.fall}} + \Delta z_{\text{creep.shrinkage}}$

Using variables defined in this example.....  $\Delta_{\text{CST}} := \Delta z_{\text{CS}} + \Delta z_{\text{TempF}}$   
 $\Delta_{\text{CST}} = 0.35 \cdot \text{in}$

Joint width from opening caused by creep, shrinkage, and temperature.....  $W_{\text{CSTopen}} := W + \Delta_{\text{CST}}$   
 $W_{\text{CSTopen}} = 1.35 \cdot \text{in}$

The joint width from opening should not exceed the maximum joint width.

$\text{CST}_{\text{Jt\_Open}} := \begin{cases} \text{"OK, joint width does not exceed maximum joint width"} & \text{if } W_{\text{CSTopen}} \leq W_{\text{max}} \\ \text{"NG, joint width exceeds maximum joint width"} & \text{otherwise} \end{cases}$

$\text{CST}_{\text{Jt\_Open}} = \text{"OK, joint width does not exceed maximum joint width"}$

### B2. Movement from Temperature [SDG 2015, 6.4.2]

Movement from factored effects of temperature rise

$$\Delta z_{\text{rise.or.fall}} = 1.15 \cdot \Delta z_{\text{temperature.rise.or.fall}}$$

Using variables defined in this example,

Joint width from opening caused by factored temperature fall.....  $W_{\text{Topen}} := W + 1.15 \cdot \Delta z_{\text{TempF}}$   
 $W_{\text{Topen}} = 1.09 \cdot \text{in}$

Joint width from closing caused by factored temperature rise.....  $W_{\text{Tclose}} := W - 1.15 \cdot \Delta z_{\text{TempR}}$   
 $W_{\text{Tclose}} = 0.91 \cdot \text{in}$

The joint width from opening should not exceed the maximum joint width.

$$\text{Temperature}_{Jt\_Open} := \begin{cases} \text{"OK, joint width does not exceed maximum joint width"} & \text{if } W_{Topen} \leq W_{max} \\ \text{"NG, joint width exceeds maximum joint width"} & \text{otherwise} \end{cases}$$

$$\text{Temperature}_{Jt\_Open} = \text{"OK, joint width does not exceed maximum joint width"}$$

The joint width from closing should not be less than the minimum joint width.

$$\text{Temperature}_{Jt\_Close} := \begin{cases} \text{"OK, joint width is not less than minimum joint width"} & \text{if } W_{Tclose} \geq W_{min} \\ \text{"NG, joint width exceeds minimum joint width"} & \text{otherwise} \end{cases}$$

$$\text{Temperature}_{Jt\_Close} = \text{"OK, joint width is not less than minimum joint width"}$$

**B3. Temperature Adjustment for Field Placement of Joint**

For field temperatures other than 70° F, a temperature adjustment is provided. The adjustment is used during construction to obtain the desired joint width.....

$$T_{Adj} := \frac{\Delta z_{TempR}}{\Delta t_{rise}}$$

$$T_{Adj} = 0.0033 \cdot \frac{\text{in}}{^{\circ}\text{F}}$$

**B4. Design Movement/Strain**

For the lateral forces into the substructure piles, the following strain due to temperature, creep and shrinkage will be utilized.....

$$\epsilon_{CST} := (\epsilon_{CR} + \epsilon_{SH} + \alpha_t \cdot \Delta t_{fall})$$

$$\epsilon_{CST} = 0.00065$$

### C. Design Summary

Joint width at 70°.....  $W = 1 \cdot \text{in}$

Joint width from opening caused by creep, shrinkage, and temperature.....

$W_{\text{CSTOpen}} = 1.35 \cdot \text{in}$

$\text{CST}_{\text{Jt\_Open}} = \text{"OK, joint width does not exceed maximum joint width"}$  .....  $W_{\text{max}} = 2 \cdot \text{in}$

Joint width from opening caused by factored temperature.....

$W_{\text{Topen}} = 1.09 \cdot \text{in}$

$\text{Temperature}_{\text{Jt\_Open}} = \text{"OK, joint width does not exceed maximum joint width"}$  .....  $W_{\text{max}} = 2 \cdot \text{in}$

Joint width from closing caused by factored temperature.....

$W_{\text{Tclose}} = 0.91 \cdot \text{in}$

$\text{Temperature}_{\text{Jt\_Close}} = \text{"OK, joint width is not less than minimum joint width"}$  .....  $W_{\text{min}} = 0.625 \cdot \text{in}$

Adjustment for field temperatures other than 70°.....

$T_{\text{Adj}} = 0.0033 \cdot \frac{\text{in}}{^{\circ}\text{F}}$

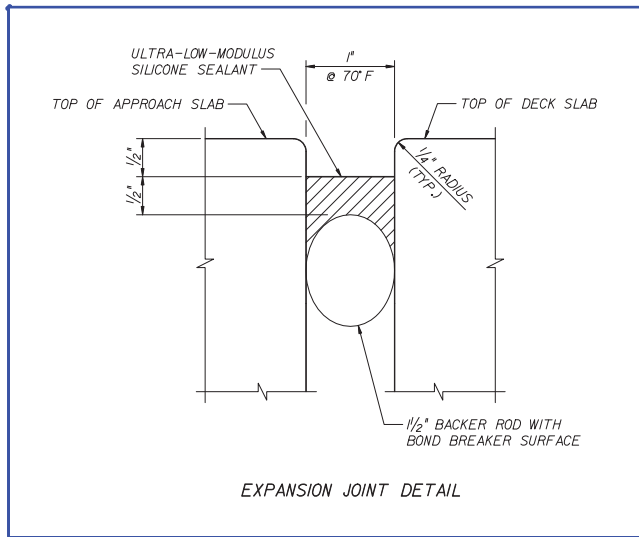

Defined Units





## SUBSTRUCTURE DESIGN

### Bent 2 Cap Design Loads

---

#### Reference (links to other Mathcad files)

-  Reference:L:\LRFD\_Design\_Example\_#2A thesis\1.03.Design\_Parameters.xmcd(R)
-  Reference:L:\LRFD\_Design\_Example\_#2A thesis\2.01.Flat\_Slab\_Design\_Loads.xmcd(R)
-  Reference:L:\LRFD\_Design\_Example\_#2A thesis\2.03.Edge\_Beam\_Design\_Loads.xmcd(R)

#### Description

This section provides the design dead loads applied to the substructure from the superstructure. The self-weight of the substructure is generated by the analysis program for the substructure model.

<b>Page</b>	<b>Contents</b>
117	<b>A. General Criteria</b> <ul style="list-style-type: none"> <li>A1. End Bent Geometry</li> <li>A2. Pier Geometry</li> <li>A3. Footing Geometry</li> <li>A4. Pile Geometry</li> </ul>
118	<b>B. Dead Loads (DC, DW)</b> <ul style="list-style-type: none"> <li>B1. Beam Dead loads</li> <li>B2. End Bent Dead loads</li> <li>B3. Pier Dead loads</li> <li>B4. End Bent and Pier Cap Dead load (DC, DW) Summary</li> </ul>

## A. General Criteria

### A1. Intermediate Bent Geometry

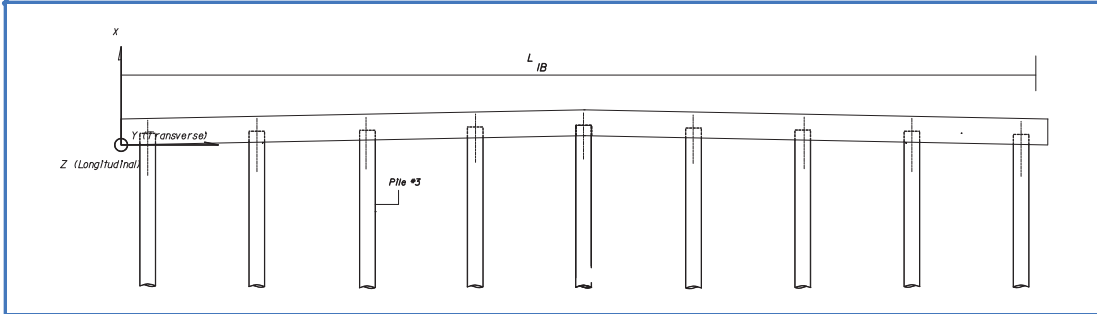

Depth of intermediate bent cap.....	$h_{cap} = 2.5 \text{ ft}$
Width of intermediate bent cap.....	$b_{cap} = 3.5 \text{ ft}$
Length of intermediate bent cap....	$L_{cap} = 11 \text{ ft}$
Pile Embedment Depth.....	$Pile_{embed} = 1 \text{ ft}$
Pile Size.....	$Pile_{size} = 1.5 \text{ ft}$
Length of intermediate bent cap	$L_{cap} = 11 \text{ ft}$
Length of edge bent cap.....	$L_{edge.cap} = 1.93 \text{ ft}$
Number of spans.....	$N_{cap} = 9$
Concrete clear cover.....	$c_c = 1.5 \text{ in}$

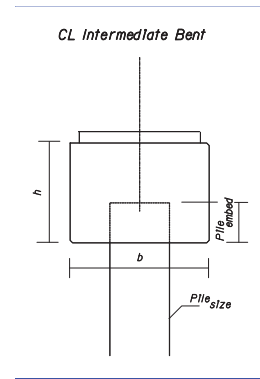

(Note: For this design example, only the intermediate bent will be evaluated).

## B. Loads (DC, DW, LL)

### B1. Longitudinal Analysis

#### Dead Loads

The dead loads of the superstructure (moment and shears) were previously computed on a per foot basis utilizing the AISC's Moments, Shears and Reactions for Continuous Highway Bridges, published 1966. The dead loads and shear could have been calculated utilizing the AISC's Steel Construction Manual - Beam Diagrams and Deflections charts. Based on the following chart, the reactions at the intermediate bent (Point B) can be calculated.

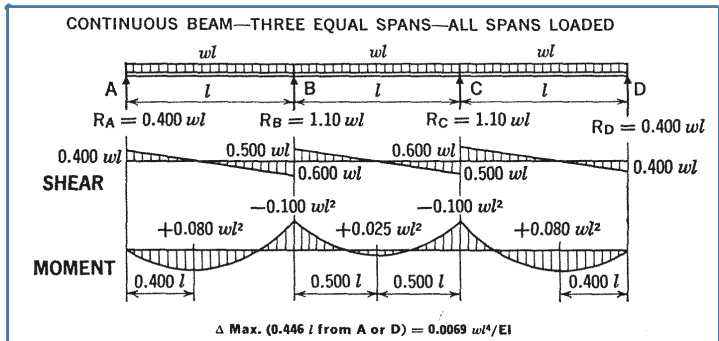

Reaction at B:  $R_B = V_{left} + V_{right}$

where based on previous calculations for dead loads:

$$w_{DC} := 0.240 \cdot \text{ksf}$$

$$w_{DW} := 0.015 \cdot \text{ksf}$$

For a 1' design strip,

$$V_{DC.left} := 0.6 \cdot w_{DC} \cdot L_{span}$$

$$V_{DC.left} = 5.04 \cdot \text{klf}$$

$$V_{DC.right} := 0.5 \cdot w_{DC} \cdot L_{span}$$

$$V_{DC.right} = 4.2 \cdot \text{klf}$$

similarly

$$V_{DW.left} := 0.6 \cdot w_{DW} \cdot L_{span}$$

$$V_{DW.left} = 0.32 \cdot \text{klf}$$

$$V_{DW.right} := 0.5 \cdot w_{DW} \cdot L_{span}$$

$$V_{DW.right} = 0.26 \cdot \text{klf}$$

the reactions at B:

$$R_{DC} := V_{DC.left} + V_{DC.right}$$

$$R_{DC} = 9.2 \cdot \text{klf}$$

$$R_{DW} := V_{DW.left} + V_{DW.right}$$

$$R_{DW} = 0.6 \cdot \text{klf}$$

*(Note: These are the same values summarized in Sect. 2.01 Design Loads - Dead Load Analysis utilizing*

**Live loads**

The live load reaction at the intermediate bent can be computed utilizing computer programs or similar methods. For purposes of this design example, the HL-93 live load reaction at B is given as:

HL-93 live load reaction at B  $R_{LL} := 112.9 \cdot \text{kip}$  (Note: Includes lane load and impact on truck;  $112.9 \text{kip} = \text{truck} (64.7 \text{kip} \times 1.33) + \text{lane} (26.88 \text{kip})$ ).

Live load reaction for an interior strip,  $E = 12.5 \text{ ft}$  .....  $R_{LL, \text{Interior}} := \frac{R_{LL}}{E}$   
 $R_{LL, \text{Interior}} = 9 \cdot \text{klf}$

Since the live load applied to the edge beam is different than an interior strip, the live load reaction for the edge beam is computed separately,

HL-93 live load reaction at B.  $R_{LL, \text{EB}} := 55.0 \cdot \text{kip}$  (Note: Includes lane load and impact on truck;  $112.9 \text{kip} = \text{truck} (64.7 \text{kip}) \times 1.33 \times 0.5 \text{ Factor}_{\text{truck}} + \text{lane} (26.88 \text{kip}) \times 0.446 \text{ Factor}_{\text{lane}}$ ).

Live load reaction for an edge beam strip,  
 $E_{\text{on lane edge}} = 6 \text{ ft}$   $R_{LL, \text{EB}} := \frac{R_{LL, \text{EB}}}{E_{\text{on lane edge}}}$   
 $R_{LL, \text{EB}} = 9.2 \cdot \text{klf}$

**B1. Transverse Analysis**

The loads calculated in the longitudinal analysis can be applied transversely for (1) design of the pier cap and (2) design of the maximum pile force.

**Pier cap design**

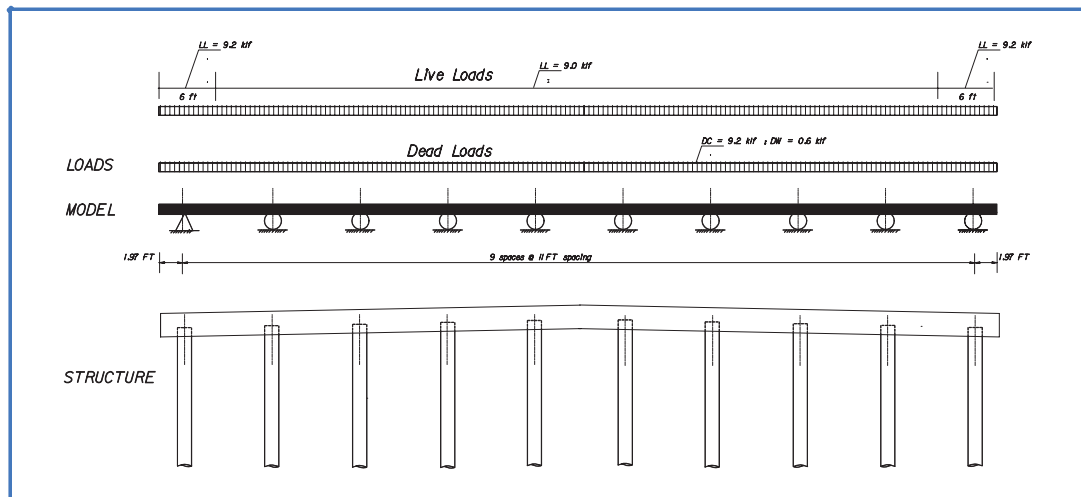



The live loads can be positioned to maximize the loads for the design of the intermediate end bent cap. For instance, for the maximum positive moment in the intermediate end bent cap, the influence line is shaped as follows:

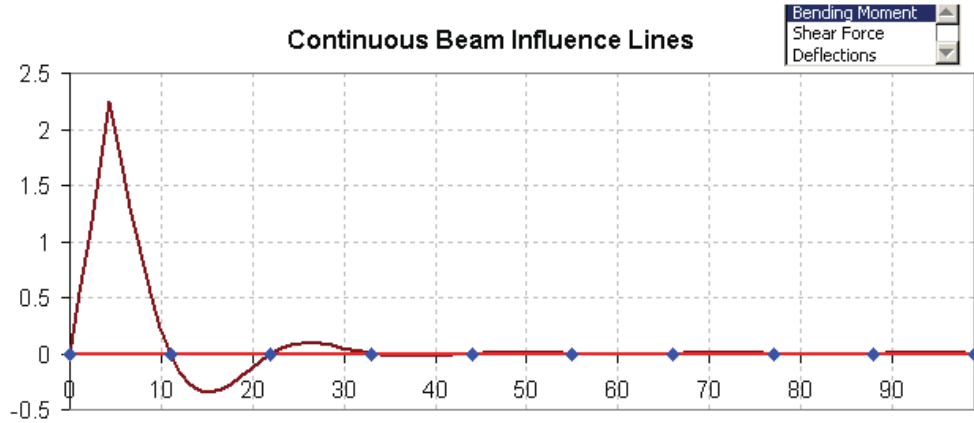

the corresponding live load loading is therefore,

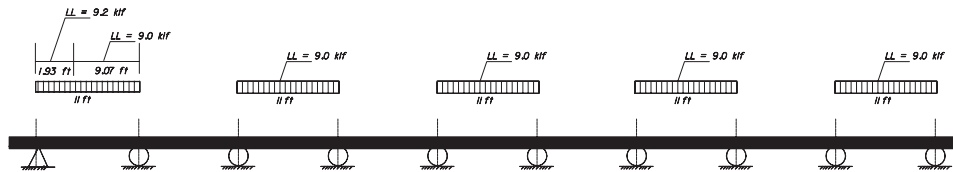

For the maximum negative moment in the intermediate end bent cap, the influence line is shaped as follows:

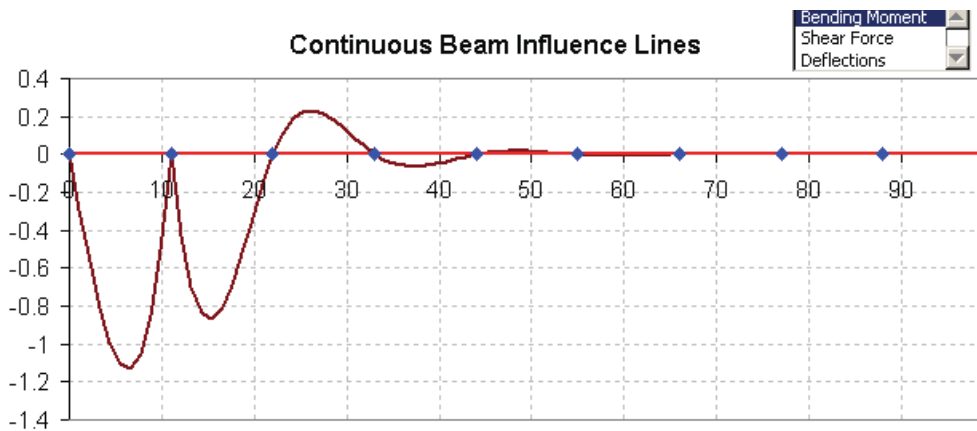

the corresponding live load loading is therefore,

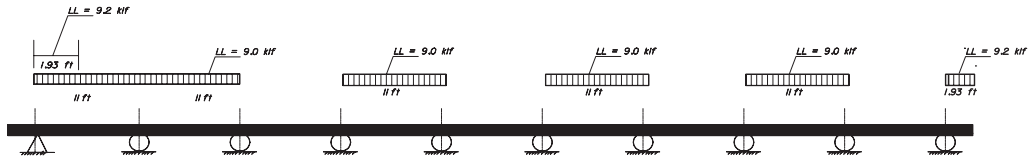

The dead load DC, DW for both superstructure and cap were evaluated, combined with the appropriate live load utilizing LARSA 2000. Any frame analysis program could be utilized to obtain the results. In addition, the load combinations were performed within LARSA for both the Service I and Strength I limit states. The following is a summary of the results:

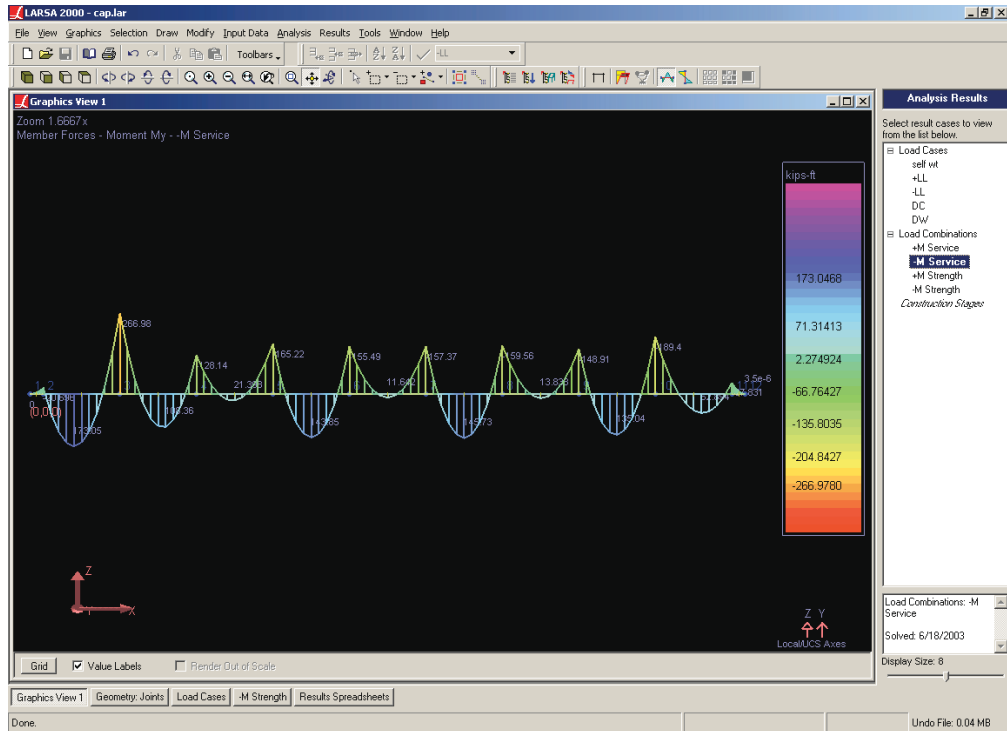

LARSA 2000 Analysis Results				
	Max. +M (ft-kip)	V (kip)	Max. -M (ft-kip)	V (kip)
Superstructure DC Moment	78.1	59.3	113.0	59.3
Superstructure DW Moment	5.1	3.9	7.4	3.9
Substructure Cap DC Moment	11.1	8.5	16.1	8.5
LL Moment	107.9	61.4	130.5	61.4
Service I Limit State	202.4	126.6	267.3	133.2
Strength I Limit State	352.5	220.5	465.9	232.1
Max. Service I Reaction	191.9	---	256.5	---
Max. Strength I Reaction	334.1	---	447.0	---





Defined Units



**SUBSTRUCTURE DESIGN**

**GFRP-reinforced Bent 2 Cap Design**

**References (links to other Mathcad files)**

-  Reference:L:\LRFD\_Design\_Example\_#2A thesis\1.03.Design\_Parameters.xmcd(R)
-  Reference:L:\LRFD\_Design\_Example\_#2A thesis\1.04.Material\_Properties.xmcd(R)
-  Reference:L:\LRFD\_Design\_Example\_#2A thesis\2.01.Flat\_Slab\_Design\_Loads.xmcd(R)
-  Reference:L:\LRFD\_Design\_Example\_#2A thesis\2.02.GFRP\_Flat\_Slab\_Design.xmcd(R)
-  Reference:L:\LRFD\_Design\_Example\_#2A thesis\3.01.Bent\_2\_Cap\_Design\_Loads.xmcd(R)

**Description**

This section provides the design for the GFRP-reinforced bent 2 cap substructure.

<b>Page</b>	<b>Contents</b>
122	<b>A. Input Variables</b>
123	<b>B. Design of Primary Reinforcement</b>
	<b>B1. Data Recall</b>
	<b>B2. Select Primary Reinforcement and Limits</b>
	<b>B3. Negative Moment Region - Flexural Strength at Support</b>
	<b>B4. Development Length at Support</b>
	<b>B5. Positive Moment Region - Flexural Strength at Middle Span</b>
	<b>B6. Development Length at Middle Span</b>
	<b>B7. Reinforcement Splices</b>
132	<b>C. Shrinkage and Temperature Reinforcement</b>
	<b>C1. Data Recall</b>
	<b>C2. Shrinkage and Temperature</b>
133	<b>D. Crack Width Verification</b>
	<b>D1. Data Recall</b>
	<b>D2. Support</b>
	<b>D3. Middle span</b>
136	<b>E. Shear Verification</b>
	<b>E1.Data Recall</b>
	<b>E1. Punching Shear Verification</b>
	<b>E2. Shear Reinforcement</b>
140	<b>F. Cap to Pile Joint Verification</b>
142	<b>G. Summary of Provided Reinforcement and Detailing</b>

**A. Input Variables**



Service and Ultimate Positive Moment

Service  $M_{\text{service1.pos}} := 202.3 \text{ ft}\cdot\text{kip}$

Strength  $M_{\text{strength1.pos}} := 352.5 \text{ ft}\cdot\text{kip}$

Service and Ultimate Negative Moment

Service  $M_{\text{service1.neg}} := 267.3 \text{ ft}\cdot\text{kip}$

Strength  $M_{\text{strength1.neg}} := 465.9 \text{ ft}\cdot\text{kip}$

Maximum shear at the interior support of the first span of the cap  $V_{\text{strength1}} := 232.1 \text{ kip}$

Maximum shear at  $d_{f1.cap}$  from pile  $V_{u.d.cap} := 124 \text{ kip}$

Maximum reaction load at support is 447.5 kip  $P_{u.2w.spt} := 447.5 \text{ kip}$



**B. Design of Primary Reinforcement**

**B1.Data recall (section B of chapter 1.04)**



$diam_{No_{pr.cap}} = 1.25 \cdot \text{in}$  Diameter of cap primary GFRP reinforcement

$area_{No_{pr.cap}} = 1.23 \cdot \text{in}^2$  Area of cap primary GFRP reinforcement

$E_{fNo_{pr.cap}} = 7142 \cdot \text{ksi}$  Modulus of elasticity of cap primary GFRP reinforcement

$f_{fuNo_{pr.cap}} = 101.3 \cdot \text{ksi}$  Tensile strength of cap primary reinforcement for product certification as reported by GFRP manufacturer [AASHTO GFRP 2009, 2.6.1.2]

$f_{fd.pr.cap} = 70.9 \cdot \text{ksi}$  Design strength of cap primary reinforcement considering reduction for service environment [AASHTO GFRP 2009, 2.6.1.2-1]

$\epsilon_{fuNo_{pr.cap}} = 1.5\%$  Tensile strain of cap primary reinforcement for product certification as reported by GFRP manufacturer [AASHTO GFRP 2009, 2.6.1.2]

$\epsilon_{fdNo.pr.cap} = 1.1\%$  Design strain of cap primary reinforcement reinforcement considering reduction for service environment [AASHTO GFRP 2009, 2.6.1.2]



**B2. Select primary reinforcement and limits**



**Preliminary GFRP reinforcement**

The failure mode depends on the amount of FRP reinforcement. If  $\rho_f$  is larger than the balanced reinforcement ratio,  $\rho_{fb}$ , then concrete crushing is the failure mode. If  $\rho_f$  is smaller than the balanced reinforcement ratio,  $\rho_{fb}$ , then FRP rupture is the failure mode.

[AASHTO GFRP 2009, 2.7.4.2-2]

$$\rho_{fb1.cap} := 0.85\beta_{1.sub} \cdot \frac{f_{c.sub}}{f_{fd.pr.cap}} \cdot \frac{E_{fNo_{pr.cap}} \cdot \epsilon_{cu}}{E_{fNo_{pr.cap}} \cdot \epsilon_{cu} + f_{fd.pr.cap}} = 0.012$$

The effective reinforcement depth is:

$$d_{f1.cap} := h_{cap} - c_c - \text{diam}_{No_{sh.cap}} - \frac{\text{diam}_{No_{pr.cap}}}{2} = 27.38 \cdot \text{in}$$

This reinforcement ratio corresponds to an area of:

$$A_{f\_req1.cap} := \rho_{fb1.cap} \cdot b_{cap} \cdot d_{f1.cap} = 13.6 \cdot \text{in}^2$$

The required number of bars is:

$$N_{f\_req1.cap} := \frac{A_{f\_req1.cap}}{\text{area}_{No_{pr.cap}}} = 11.1$$

The corresponding required spacing is:

$$s_{f\_req1.cap} := \frac{b_{cap} - N_{f\_req1.cap} \cdot \text{diam}_{No_{pr.cap}}}{N_{f\_req1.cap}} = 2.5 \cdot \text{in}$$

Therefore, the number of bars chosen for 3.5 ft-cap-width is:

$$N_{f\_des1.cap} := 12$$

The corresponding bar spacing is selected:

$$s_{f\_des1.cap} := \frac{b_{cap} - 2 \cdot \text{diam}_{No_{sh.cap}} - 2 \cdot c_c}{N_{f\_des1.cap}} = 3.17 \cdot \text{in}$$

The corresponding bar spacing

$$s_{f\_bar1.cap} := 3.15 \text{in}$$

The minimum required clear bar spacing for single bar is:

[AASHTO GFRP 2009, 2.11.3.1]

$$s_{f\_min1.cap} := \max(1.5 \cdot \text{in}, 1.5 \cdot \text{diam}_{No_{pr.cap}}) = 1.9 \cdot \text{in}$$

The bar clear spacing for single bar is

$$s_{f\_bar1.clr.cap} := s_{f\_bar1.cap} - \text{diam}_{No_{pr.cap}} = 1.9 \cdot \text{in}$$

Check for minimum spacing of single bar for cap design:

$$\text{Check\_CapSingleBarSpacing1} := \begin{cases} \text{"VERIFIED"} & \text{if } s_{f\_bar1.clr.cap} \geq s_{f\_min1.cap} \\ \text{"TOO MANY BARS"} & \text{otherwise} \end{cases}$$

Check\_CapSingleBarSpacing1 = "VERIFIED"

Check for cap width availability for distribution of flexure reinforcement:

$$\text{Check\_Fl\_Reinf} := \begin{cases} \text{"CAP WIDTH SUFFICIENT FOR FLEXURAL REINFORCEMENT"} & \text{if } s_{f\_des1.cap} \geq s_{f\_bar1.cap} \\ \text{"REDESIGN"} & \text{otherwise} \end{cases}$$

Check\_Fl\_Reinf = "CAP WIDTH SUFFICIENT FOR FLEXURAL REINFORCEMENT"

The area of FRP reinforcement is:

$$A_{f1.cap} := N_{f\_des1.cap} \cdot \text{area}_{No_{pr.cap}} = 14.72 \cdot \text{in}^2$$

The FRP reinforcement ratio is:

$$\rho_{f1.cap} := \frac{A_{f1.cap}}{b_{cap} \cdot d_{f1.cap}} = 0.01281$$

#### **Limit for Reinforcement-Minimum Reinforcement**

[AASHTO GFRP 2009, 2.9.3.3-1]

$$A_{f.min.cap} := \max(0.33 \text{ksi}, 0.16 \cdot \sqrt{f_{c.sub} \cdot \text{ksi}}) \cdot \frac{b_{cap} \cdot d_{f1.cap}}{f_{fd.pr.cap}} = 6.1 \cdot \text{in}^2$$

$$\text{Check\_CapFlexureMinReinforcement} := \begin{cases} \text{"VERIFIED"} & \text{if } A_{f1.cap} \geq A_{f.min.cap} \\ \text{"NOT VERIFIED"} & \text{otherwise} \end{cases}$$

Check\_CapFlexureMinReinforcement = "VERIFIED"



### **B3. Negative moment region - flexural strength at support**



$\text{diam}_{No_{pr.cap}} = 1.25 \cdot \text{in}$  Diameter of cap primary GFRP reinforcement

$\text{area}_{No_{pr.cap}} = 1.23 \cdot \text{in}^2$  Area of cap primary GFRP reinforcement

$N_{f\_des1.cap} = 12$  Number of GFRP bars for negative moment

$A_{f1.cap} = 14.7 \cdot \text{in}^2$  Area of GFRP bars for negative moment

$f_{fd.pr.cap} = 70.9 \cdot \text{ksi}$  Design strength of cap primary reinforcement considering reduction for service environment

$$M_{\text{strength1.neg}} = 465.9 \cdot \text{kip} \cdot \text{ft}$$

Maximum negative moment demand

### Flexural strength computed as per AASHTO GFRP 2009

Maximum tensile stress is computed as follows:

[AASHTO GFRP 2009, 2.9.3.1-1]

$$f_{f1.cap} := \begin{cases} \sqrt{\frac{\left[ \left( E_{fNo.pr.cap} \right) \cdot \epsilon_{cu} \right]^2}{4} + \frac{0.85 \beta_{1.sub} \cdot f_{c.sub}}{\rho_{f1.cap}} E_{fNo.pr.cap} \cdot \epsilon_{cu} - 0.5 E_{fNo.pr.cap} \cdot \epsilon_{cu}} & \text{if } \rho_{f1.cap} \geq \rho_{fb1.cap} \\ f_{fu} & \text{otherwise} \end{cases}$$

$$f_{f1.cap} = 67.9 \cdot \text{ksi}$$

$f_f$  cannot exceed  $f_{fu}$ , therefore, the following has to be checked:

$$\text{CheckCapMaxStress1} := \begin{cases} \text{"VERIFIED"} & \text{if } f_{f1.cap} \leq f_{fd.pr.cap} \\ \text{"REDUCE BAR SPACING OR INCREASE BAR SIZE"} & \text{otherwise} \end{cases}$$

CheckCapMaxStress1 = "VERIFIED"

The stress-block depth is computed as per Eq.2.9.3.2.2-2 or Eq.2.9.3.2.2-4 whether  $\rho_f > \rho_{fb}$  or  $\rho_f < \rho_{fb}$ , respectively.

$$a_{f1.cap} := \frac{A_{f1.cap} \cdot f_{f1.cap}}{0.85 \cdot f_{c.super} \cdot b_{cap}} = 6.22 \cdot \text{in} \quad [\text{AASHTO GFRP 2009, 2.9.3.2.2-2}]$$

Neutral axis depth  $c_b$  at balanced strain conditions:

$$c_{b1.cap} := \left( \frac{\epsilon_{cu}}{\epsilon_{cu} + \epsilon_{fdNo.pr.cap}} \right) \cdot d_{f1.cap} = 6.1 \cdot \text{in} \quad [\text{AASHTO GFRP 2009, 2.9.3.2.2-4}]$$

The nominal moment capacity is: [AASHTO GFRP 2009, 2.9.3.2.2-1, 2.9.3.2.2-3]

$$M_{nAASHTO\_1.cap} := \begin{cases} A_{f1.cap} \cdot f_{f1.cap} \cdot \left( d_{f1.cap} - \frac{a_{f1.cap}}{2} \right) & \text{if } \rho_{f1.cap} \geq \rho_{fb1.cap} \\ A_{f1.cap} \cdot f_{f1.cap} \cdot \left( d_{f1.cap} - \frac{\beta_{1.sub} \cdot c_{b1.cap}}{2} \right) & \text{otherwise} \end{cases}$$

$$M_{nAASHTO\_1.cap} = 2020.9 \cdot \text{kip} \cdot \text{ft}$$



The strength reduction factor for cap is computed as follows:

[AASHTO GFRP 2009, 2.7.4.2-1 ]

$$\phi_{f\_1.cap} := \begin{cases} 0.55 & \text{if } \rho_{f1.cap} \leq \rho_{fb1.cap} \\ 0.30 + 0.25 \cdot \frac{\rho_{f1.cap}}{\rho_{fb1.cap}} & \text{if } \rho_{fb1.cap} < \rho_{f1.cap} < 1.4 \cdot \rho_{fb1.cap} \\ 0.65 & \text{otherwise} \end{cases}$$

$$\phi_{f\_1.cap} = 0.57$$

The design flexural strength is computed as:

$$\phi_{f\_1.cap} \cdot M_{nAASHTO\_1.cap} = 1152 \cdot \text{kip} \cdot \text{ft}$$

$$\text{Recall } M_{\text{strength1.neg}} = 465.9 \cdot \text{kip} \cdot \text{ft}$$

$$\text{Check\_CapFlexureAASHTO\_1} := \begin{cases} \text{"VERIFIED"} & \text{if } \phi_{f\_1.cap} \cdot M_{nAASHTO\_1.cap} \geq M_{\text{strength1.neg}} \\ \text{"NOT VERIFIED"} & \text{otherwise} \end{cases}$$

Check\_CapFlexureAASHTO\_1 = "VERIFIED"



#### B4. Development length at support



At least 1/3 of the total tension reinforcement provided for negative moment at a support shall have an embedment length  $L_{d.neg.min}$  beyond the point of inflection as follows:

In this case, 6 #10 GFRP bars are distributed along the entire span in the middle of cap span, the remaining 6 #10 GFRP bars can be terminated at the point of inflection with the following  $L_{d.neg.min}$ :

At edge section of cap span:

$$L_{d.neg.min.cap} := \max \left( d_{f1.cap}, 15 \cdot \text{diam}_{No_{pr.cap}}, \frac{L_{cap}}{20} \right) = 2.3 \cdot \text{ft}$$

At the intermediate section of cap span:

Reinforcement is distributed along the entire span of cap.

6 #10 bars (1/2 of the total) have a length beyond the point of inflection of 2.5 ft.

Based on the bending moment envelope, the negative moment extends 2 ft from supports. Hence, the design length is selected to be at least 7 ft, distributed 3.5 ft to the left and right supports.

The remaining 6 #10 bars for negative moment cover the entire span in the middle of cap.

Lap splices are covered at end of the flexural design (section B7).



#### B5. Positive moment region - flexural strength at middle span



$$\text{diam}_{No_{pr.cap}} = 1.25 \cdot \text{in}$$

Diameter of cap primary GFRP reinforcement



$area_{No_{pr.cap}} = 1.23 \cdot in^2$	Area of cap primary GFRP reinforcement
$N_{f\_des1.cap} = 12$	Number of GFRP bars for positive moment
$A_{f2.cap} := A_{f1.cap} = 14.7 \cdot in^2$	Area of GFRP bars for positive moment
$d_{f2.cap} := d_{f1.cap} = 27.4 \cdot in$	The effective reinforcement depth
$s_{f\_bar2.cap} := s_{f\_bar1.cap} = 3.2 \cdot in$	The reinforcing spacing
$f_{fd.pr.cap} = 70.9 \cdot ksi$	Design strength of cap primary reinforcement considering reduction for service environment
$M_{strength1.pos} = 352.5 \cdot kip \cdot ft$	Maximum negative moment demand
$\rho_{f2.cap} := \frac{A_{f2.cap}}{b_{cap} \cdot d_{f2.cap}} = 0.013$	GFRP reinforcement ratio
The balanced reinforcement ratio, $\rho_{fb}$ is computed as follows:	
[AASHTO GFRP 2009, 2.7.4.2-2]	
$\rho_{fb2.cap} := 0.85 \beta_{1.sub} \cdot \frac{f_{c.sub}}{f_{fd.pr.cap}} \cdot \frac{E_{fNo_{pr.cap}} \cdot \epsilon_{cu}}{E_{fNo_{pr.cap}} \cdot \epsilon_{cu} + f_{fd.pr.cap}} = 0.012$	
<b><u>Flexural strength computed as per AASHTO GFRP 2009</u></b>	
The tensile stress in the GFRP is computed as follows:	
[AASHTO GFRP 2009, 2.9.3.1-1]	
$f_{f2.cap} := \begin{cases} \sqrt{\frac{(E_{fNo_{pr.cap}} \cdot \epsilon_{cu})^2}{4} + \frac{0.85 \beta_{1.sub} \cdot f_{c.sub}}{\rho_{f2.cap}} E_{fNo_{pr.cap}} \cdot \epsilon_{cu}} - 0.5 E_{fNo_{pr.cap}} \cdot \epsilon_{cu}} & \text{if } \rho_{f2.cap} \geq \rho_{fb2.cap} \\ f_{fd.pr.cap} & \text{otherwise} \end{cases}$	
$f_{f2.cap} = 67.9 \cdot ksi$	
$f_f$ cannot exceed $f_{fv}$ therefore, the following has to be checked:	
Recall $f_{fd.pr.cap} = 70.9 \cdot ksi$	
CheckCapMaxStress2 := $\begin{cases} \text{"VERIFIED"} & \text{if } f_{f2.cap} \leq f_{fd.pr.cap} \\ \text{"REDUCE BAR SPACING OR INCREASE BAR SIZE"} & \text{otherwise} \end{cases}$	
CheckCapMaxStress2 = "VERIFIED"	
The stress-block depth is computed as per Eq. (2.9.3.2.2-2) or Eq. (2.9.3.2.2-4) whether $\rho_f > \rho_{fb}$ or $\rho_f < \rho_{fb}$ , respectively.	
$a_{f2.cap} := \frac{A_{f2.cap} \cdot f_{f2.cap}}{0.85 \cdot f_{c.super} \cdot b_{cap}} = 6.22 \cdot in$ [AASHTO GFRP 2009, 2.9.3.2.2-2]	

Neutral axis depth  $c_b$  at balanced strain conditions:

$$c_{b2.cap} := \left( \frac{\epsilon_{cu}}{\epsilon_{cu} + \epsilon_{fdNo.pr.cap}} \right) \cdot d_{f2.cap} = 6.1 \cdot \text{in} \quad [\text{AASHTO GFRP 2009, 2.9.3.2.2-4}]$$

The nominal moment capacity is: [AASHTO GFRP 2009, 2.9.3.2.2-1, 2.9.3.2.2-3]

$$M_{nAASHTO\_2.cap} := \begin{cases} A_{f2.cap} \cdot f_{f2.cap} \cdot \left( d_{f2.cap} - \frac{a_{f2.cap}}{2} \right) & \text{if } \rho_{f2.cap} \geq \rho_{fb2.cap} \\ A_{f2.cap} \cdot f_{f2.cap} \cdot \left( d_{f2.cap} - \frac{\beta_{1.sub} \cdot c_{b2.cap}}{2} \right) & \text{otherwise} \end{cases}$$

$$M_{nAASHTO\_1.cap} = 2020.9 \cdot \text{kip} \cdot \text{ft}$$



The strength reduction factor for cap is calculated as follows:

[AASHTO GFRP 2009, Equation(2.7.4.2-1)]

$$\phi_{f\_2.cap} := \begin{cases} 0.55 & \text{if } \rho_{f2.cap} \leq \rho_{fb2.cap} \\ 0.30 + 0.25 \cdot \frac{\rho_{f2.cap}}{\rho_{fb2.cap}} & \text{if } \rho_{fb2.cap} < \rho_{f2.cap} < 1.4 \cdot \rho_{fb2.cap} \\ 0.65 & \text{otherwise} \end{cases}$$

$$\phi_{f\_2.cap} = 0.57$$

The design flexural strength is computed as:

$$\phi_{f\_2.cap} \cdot M_{nAASHTO\_2.cap} = 1152 \cdot \text{kip} \cdot \text{ft}$$

$$\text{Recall } M_{\text{strength1.pos}} = 353 \cdot \text{kip} \cdot \text{ft}$$

$$\text{Check\_CapFlexureAASHTO\_2} := \begin{cases} \text{"VERIFIED"} & \text{if } \phi_{f\_2.cap} \cdot M_{nAASHTO\_2.cap} \geq M_{\text{strength1.pos}} \\ \text{"NOT VERIFIED"} & \text{otherwise} \end{cases}$$

Check\_CapFlexureAASHTO\_2 = "VERIFIED"



## B6. Development length at middle span



According to [AASHTO GFRP 2009 2.12.1.2], reinforcement extends not less than the development length,  $L_{d,pos}$  beyond the point at which it is no longer required to resist flexure. And no more than 50% should be terminated at any section

[AASHTO GFRP 2009, 2.12.1.2]

At the intermediate section of cap span:

$$L_{d,pos.cap} := \max \left( h_{cap}, 15 \cdot \text{diam}_{No.pr.cap}, \frac{L_{cap}}{20} \right) = 2.5 \cdot \text{ft} \quad [\text{AASHTO GFRP 2009, 2.12.1.2.1}]$$

At the edge section of cap span:

Reinforcement is distributed along the entire length of the cap.

Therefore, the provided development length  $L_{d, \text{pos. cap. sl}}$  is chosen to be 2.5 ft, which is not less than the required  $L_d$ .

$$L_{d, \text{pos. cap. sl}} := 2.5 \text{ ft}$$

In addition,  $L_{d, \text{pos. sl}}$  should be also satisfied equation 2.12.1.2.2-1

[AASHTO GFRP 2009, Equation(2.12.1.2.2-1)]

$$L_{d, \text{pos. cap. max}} := \frac{M_{n \text{ AASHTO } 1, \text{ cap}}}{V_{\text{strength1}}} + 12 \cdot d_{f2, \text{ cap}} = 36.1 \cdot \text{ft}$$

$$\text{CheckingCapDevelopmentLength}_{\text{pos}} := \begin{cases} \text{"VERIFIED"} & \text{if } L_{d, \text{pos. cap. sl}} \leq L_{d, \text{pos. cap. max}} \\ \text{"NOT VERIFIED"} & \text{otherwise} \end{cases}$$

$$\text{CheckingCapDevelopmentLength}_{\text{pos}} = \text{"VERIFIED"}$$

6 #10 bars (1/2 of the total) should have an embedment length beyond the point of inflection that is chosen to be 2.5 ft.

Based on the bending moment envelope, the positive moment in the first and third span extend for 4 ft, Therefore, 6 #10 bars will have a length of 9 ft and terminate 0.5 in from the face of pile.

The remaining 6 #10 bars cover the entire length of cap.

Lap splices are covered at end of the flexural design (section B7).



## B7. Reinforcement splices



The tension lap splice length ( $L_{sp}$ ) should satisfy AASHTO GFRP 2009 2.12.2.1 and 2.12.4

Development Length for deformed bars in tension is defined as  $L_{d, \text{tension}}$ .

Bar location modification factor  $\alpha$ , takes values of 1 except for bars with more than 12 in of concrete cast below for which a value of 1.5 shall be adopted.  $\alpha$  is 1.5 for negative moment reinforcement while  $\alpha=1$  for positive moment.

$$\alpha_{\text{neg. cap}} := 1.5$$

$$\alpha_{\text{pos. cap}} := 1$$

[AASHTO GFRP 2009, 2.10.3.1-1]

$$L_{d, \text{tension. neg. cap}} := \text{diam}_{\text{No. pr. cap}} \cdot \frac{\left( 31.6 \cdot \alpha_{\text{neg. cap}} \cdot \frac{f_{f1, \text{ cap}}}{\sqrt{f_{c, \text{ sub}} \cdot \text{ksi}}} \right) - 340}{13.6 + \frac{c_c}{d_{f1, \text{ cap}}}} = 94.5 \cdot \text{in}$$

$$L_{d,tension,pos, cap} := \text{diam}_{No,pr, cap} \cdot \frac{\left( 31.6 \cdot \alpha_{pos, cap} \cdot \frac{f_{f2, cap}}{\sqrt{f_{c, sub} \cdot \text{ksi}}} \right) - 340}{13.6 + \frac{c_c}{d_{f2, cap}}} = 52.6 \cdot \text{in}$$

[AASHTO GFRP 2009, 2.12.4]

$$L_{sp, req, neg, cap} := \max(12 \text{in}, 1.3 \cdot L_{d, tension, neg, cap}) = 122.8 \cdot \text{in}$$

$$L_{sp, req, pos, cap} := \max(12 \text{in}, 1.3 \cdot L_{d, tension, pos, cap}) = 68.4 \cdot \text{in}$$

Lap splice length  $L_{sp, sl}$  selected is:

$$\text{For negative moment region: } L_{sp, sl, neg, cap} := 123 \text{in}$$

$$\text{For positive moment region: } L_{sp, sl, pos, cap} := 69 \text{in}$$

Reduction of splice length for excess of reinforcement [ACI318-14 25.4.10]. It is suggested to adopt a limit of 0.6:

$$\text{area}_{required, neg, cap} := \frac{M_{strength1, pos}}{f_{fd, pr, cap} \cdot \left( d_{f1, cap} - \frac{\beta_{1, sub} \cdot c_{b1, cap}}{2} \right)} = 2.4 \cdot \text{in}^2 \quad [\text{AASHTO GFRP 2009, 2.9.3.2.2-3}]$$

$$\text{area}_{required, pos, cap} := \frac{M_{strength1, neg}}{f_{fd, pr, cap} \cdot \left( d_{f1, cap} - \frac{\beta_{1, sub} \cdot c_{b1, cap}}{2} \right)} = 3.1 \cdot \text{in}^2 \quad [\text{AASHTO GFRP 2009, 2.9.3.2.2-3}]$$

Area per linear foot required at midspan and support, considering the section under-reinforced ( $\rho_f < \rho_{fb}$ )

$$\text{area}_{provided, cap} := A_{f1, cap} = 14.7 \cdot \text{in}^2 \quad \text{area per linear foot provided at midspan and support (symmetric)}$$

$$\text{over\_reinf\_ratio}_{cap, neg} := \begin{cases} \frac{\text{area}_{required, neg, cap}}{\text{area}_{provided, cap}} & \text{if } \frac{\text{area}_{required, neg, cap}}{\text{area}_{provided, cap}} \geq 0.6 \\ 0.6 & \text{otherwise} \end{cases}$$

$$\text{over\_reinf\_ratio}_{cap, pos} := \begin{cases} \frac{\text{area}_{required, pos, cap}}{\text{area}_{provided}} & \text{if } \frac{\text{area}_{required, pos, cap}}{\text{area}_{provided}} \geq 0.6 \\ 0.6 & \text{otherwise} \end{cases}$$

$$\text{over\_reinf\_ratio}_{cap, neg} = 0.6$$

$$\text{over\_reinf\_ratio}_{cap, pos} = 0.9$$

$$L_{tension, neg, reduced, cap} := L_{d, tension, neg, cap} \cdot \text{over\_reinf\_ratio}_{cap, neg} = 56.7 \cdot \text{in} \quad [\text{ACI318-14 25.4.10}]$$

$$L_{tension, pos, reduced, cap} := L_{d, tension, pos, cap} \cdot \text{over\_reinf\_ratio}_{cap, pos} = 45 \cdot \text{in} \quad [\text{ACI318-14 25.4.10}]$$



Lap splice length  $L_{sp,sl}$  :

$$L_{sp,neg.cap} := \max(12\text{in}, 1.3 \cdot L_{\text{tension,neg.reduced.cap}}) = 74\text{in} \quad [\text{AASHTO GFRP 2009, 2.12.4}]$$

$$L_{sp,pos.cap} := \max(12\text{in}, 1.3 \cdot L_{\text{tension,pos.reduced.cap}}) = 59\text{in} \quad [\text{AASHTO GFRP 2009, 2.12.4}]$$

## C. Shrinkage and Temperature Reinforcement

### C1.Data recall (section B of chapter 1.04)



$\text{diam}_{\text{No.pr.cap}} = 1.3\text{-in}$  Diameter of cap primary GFRP reinforcement

$\text{area}_{\text{No.pr.cap}} = 1.2\text{-in}^2$  Area of cap primary GFRP reinforcement

$E_{f\text{No.pr.cap}} = 7.1 \times 10^3\text{-ksi}$  Modulus of elasticity of cap primary GFRP reinforcement

$f_{fu\text{No.pr.cap}} = 101.3\text{-ksi}$  Tensile strength of cap primary reinforcement for product certification as reported by GFRP manufacturer [AASHTO GFRP 2009, 2.6.1.2]

$f_{fd.pr.cap} = 70.9\text{-ksi}$  Design strength of cap primary reinforcement considering reduction for service environment [AASHTO GFRP 2009, 2.6.1.2-1]

$\epsilon_{fu\text{No.pr.cap}} = 1.5\%$  Tensile strain of cap primary reinforcement for product certification as reported by GFRP manufacturer [AASHTO GFRP 2009, 2.6.1.2]

$\epsilon_{fd\text{No.pr.cap}} = 1.1\%$  Design strain of cap primary reinforcement considering reduction for service environment [AASHTO GFRP 2009, 2.6.1.2]



### C2.Shrinkage and temperature reinforcement



The ratio of GFRP shrinkage and temperature reinforcement area to gross concrete area  $\rho_{f,st}$ :

Modulus of Elasticity of Steel  $E_s = 2.9 \times 10^4\text{-ksi}$

[AASHTO GFRP 2009, 2.11.5]

$$\rho_{f,st, \text{cap}} := \min \left( \max \left( 0.0014, 0.0018 \cdot \frac{60\text{ksi}}{f_{fd.pr.cap}} \cdot \frac{E_s}{E_{f\text{No.pr.cap}}} \right), 0.0036 \right) = 0.004$$

$$A_{g,\text{cap}} := b_{\text{cap}} \cdot h_{\text{cap}} = 1260\text{-in}^2$$

GFRP shrinkage and temperature reinforcement area  $A_{st}$

$$A_{st,\text{cap}} := \rho_{f,st,\text{cap}} \cdot A_{g,\text{cap}} = 4.5\text{-in}^2$$

$$\text{Recall } A_{f1,\text{cap}} = 14.7\text{-in}^2$$

Check for the need to provide shrinkage and temperature reinforcement

CheckCapSTNeed :=  $\begin{cases} \text{"NO ADDITIONAL SHRINKAGE AND TEMPERATURE REINFORCEMENT"} & \text{if } A_{fl.cap} \geq A_{st} \\ \text{"EXTRA SHRINKAGE AND TEMPERATURE REINFORCEMENT NEEDED"} & \text{otherwise} \end{cases}$

CheckCapSTNeed = "NO ADDITIONAL SHRINKAGE AND TEMPERATURE REINFORCEMENT"

The area of flexure reinforcement is sufficient to cover the reinforcement of shrinkage and temperature.

The max spacing for shrinkage and temperature  $S_{st,max}$  is:

[AASHTO GFRP 2009, 2.11.5]

$$S_{st,max, cap} := \min(3 \cdot h_{cap}, 12 \text{ in}, s_{f\_bar1, cap}) = 3.2 \text{ in}$$

Check\_Cap\_ST\_Spacing :=  $\begin{cases} \text{"VERIFIED"} & \text{if } s_{f\_bar1, cap} \leq S_{st,max, cap} \\ \text{"NOT VERIFIED"} & \text{otherwise} \end{cases}$  [AASHTO GFRP 2009, 2.11.5]

Check\_Cap\_ST\_Spacing = "VERIFIED"

No additional shrinkage and temperature reinforcement is required.



## D. Crack width Verification

### D1. Data recall (section B of chapter 1.04)



Crack width is checked using Equation 2.9.3.4-1 of AASHTO GFRP 2009. A crack width limit,  $w_{lim}$ , of 0.020 in. is used.

$$w_{lim} := 0.02 \text{ in}$$

Crack width limit

$$\text{diam}_{No_{pr.cap}} = 1.25 \text{ in}$$

Diameter of cap primary GFRP reinforcement

$$\text{area}_{No_{pr.cap}} = 1.23 \text{ in}^2$$

Area of cap primary GFRP reinforcement

$$E_{fNo_{pr.cap}} = 7142 \text{ ksi}$$

Modulus of elasticity of cap primary GFRP reinforcement

$$f_{fuNo_{pr.cap}} = 101.3 \text{ ksi}$$

Tensile strength of cap primary reinforcement for product certification as reported by GFRP manufacturers [AASHTO GFRP 2009, 2.6.1.2]

$$f_{fd,pr.cap} = 70.9 \text{ ksi}$$

Design strength of cap primary reinforcement considering reduction for service environment [AASHTO GFRP 2009, 2.6.1.2-1]

$$\epsilon_{fuNo_{pr.cap}} = 1.5\%$$

Tensile strain of cap primary reinforcement for product certification as reported by GFRP manufacturers [AASHTO GFRP 2009, 2.6.1.2]

$$\epsilon_{fdNo_{pr.cap}} = 1.1\%$$

Design strain of cap primary reinforcement reinforcement considering reduction for service environment [AASHTO GFRP 2009, 2.6.1.2]



### D2. Support



The crack width is checked using Equation 2.9.3.4-1. A crack width limit,  $w_{lim}$ , of 0.020 in. is used.

$$w_{lim} = 0.02 \cdot \text{in}$$

Ratio of modulus of elasticity of bars to modulus of elasticity of concrete

$$n_{f.cap} := \frac{E_{fNo_{pr.cap}}}{E_{c.sub}} = 1.9$$

Ratio of depth of neutral axis to reinforcement depth

$$k_{1.cap} := \sqrt{2\rho_{f1.cap} \cdot n_{f.cap} + (\rho_{f1.cap} \cdot n_{f.cap})^2} - \rho_{f1.cap} \cdot n_{f.cap} = 0.2$$

Tensile stress in GFRP under service loads

$$f_{fs1.cap} := \frac{M_{service1.neg}}{A_{f1.cap} \cdot d_{f1.cap} \cdot \left(1 - \frac{k_{1.cap}}{3}\right)} = 8.5 \cdot \text{ksi}$$

Ratio of distance from neutral axis to extreme tension fiber to distance from neutral axis to center of tensile reinforcement

$$\beta_{11.cap} := \frac{h_{cap} - k_{1.cap} \cdot d_{f1.cap}}{d_{f1.cap} \cdot (1 - k_{1.cap})} = 1.1$$

Thickness of concrete cover measured from extreme tension fiber to center of bar

$$d_{c1.cap} := h_{cap} - d_{f1.cap} = 2.6 \cdot \text{in}$$

Bond factor (provided by the manufacturer)

$$k_b = 0.9$$

The crack width under service loads is: [AASHTO GFRP 2009, 2.9.3.4-1]

$$w_{1.cap} := 2 \frac{f_{fs1.cap}}{E_{fNo_{pr.cap}}} \beta_{11.cap} \cdot k_b \cdot \sqrt{d_{c1.cap}^2 + \left(\frac{s_{f\_bar1.cap}}{2}\right)^2} = 0.007 \cdot \text{in}$$

The crack width limit is:

$$\text{Check\_CapCrack1} := \begin{cases} \text{"VERIFIED"} & \text{if } w_{1.cap} \leq w_{lim} \\ \text{"NOT VERIFIED"} & \text{otherwise} \end{cases}$$

**Check\_CapCrack1 = "VERIFIED"**

The maximum recommended bar spacing to limit cracking is: [ACI 440.1R 9.1.3(a)]

$$s_{Ospina\_1.cap} := \min \left( 1.15 \cdot \frac{E_{fNo_{pr.cap}} \cdot w_{lim}}{f_{fs1.cap} \cdot k_b} - 2.5 \cdot c_c, 0.92 \cdot \frac{E_{fNo_{pr.cap}} \cdot w_{lim}}{f_{fs1.cap} \cdot k_b} \right) = 17.2 \cdot \text{in}$$

Check\_CapSpacing1 :=  $\begin{cases} \text{"VERIFIED"} & \text{if } s_{f\_bar1.cap} \leq s_{Ospina\_1.cap} \\ \text{"NOT VERIFIED"} & \text{otherwise} \end{cases}$

Check\_CapSpacing1 = "VERIFIED"



### D3. Middle Span



The crack width is checked using Equation (2.9.3.4-1). A crack width limit,  $w_{lim}$ , of 0.020 in. is used.

$$w_{lim} = 0.02 \cdot \text{in}$$

Ratio of modulus of elasticity of bars to modulus of elasticity of concrete

$$n_{f.cap} = 1.9$$

Ratio of depth of neutral axis to reinforcement depth

$$k_{2.cap} := k_{1.cap} = 0.2$$

Bar spacing

$$s_{f\_bar2.cap} = 3.2 \cdot \text{in}$$

Tensile stress in GFRP under service loads

$$f_{fs2.cap} := \frac{M_{service1.pos}}{A_{f2.cap} \cdot d_{f2.cap} \cdot \left(1 - \frac{k_{2.cap}}{3}\right)} = 6.4 \text{ ksi}$$

Ratio of distance from neutral axis to extreme tension fiber to distance from neutral axis to center of tensile reinforcement

$$\beta_{12.cap} := \frac{h_{cap} - k_{2.cap} \cdot d_{f2.cap}}{d_{f2.cap} \cdot (1 - k_{2.cap})} = 1.1$$

Thickness of concrete cover measured from extreme tension fiber to center of bar:

$$d_{c2.cap} := h_{cap} - d_{f2.cap} = 2.6 \cdot \text{in}$$

Bond factor (provided by the manufacturer):

$$k_b = 0.9$$

The crack width under service loads is:

[AASHTO GFRP 2009, 2.9.3.4-1]

$$w_{2.cap} := 2 \frac{f_{fs2.cap}}{E_{fNo_{pr.cap}}} \beta_{12.cap} \cdot k_b \cdot \sqrt{d_{c2.cap}^2 + \left(\frac{s_{f\_bar2.cap}}{2}\right)^2} = 0.006 \cdot \text{in}$$



Check\_CapCrack2 :=  $\begin{cases} \text{"VERIFIED"} & \text{if } w_{l,\text{cap}} \leq w_{\text{lim}} \\ \text{"NOT VERIFIED"} & \text{otherwise} \end{cases}$

Check\_CapCrack2 = "VERIFIED"

The maximum recommended bar spacing to limit cracking is:

[ACI 440.1R 9.1.3(a)]

$$s_{\text{Ospina}_2,\text{cap}} := \min \left( 1.15 \cdot \frac{E_{f\text{No}_{pr,\text{cap}}} \cdot w_{\text{lim}}}{f_{s2,\text{cap}} \cdot k_b} - 2.5 \cdot c_c, 0.92 \cdot \frac{E_{f\text{No}_{pr,\text{cap}}} \cdot w_{\text{lim}}}{f_{s2,\text{cap}} \cdot k_b} \right) = 22.7 \cdot \text{in}$$

Check\_CapSpacing2 :=  $\begin{cases} \text{"VERIFIED"} & \text{if } s_{f\_bar2,\text{cap}} \leq s_{\text{Ospina}_2,\text{cap}} \\ \text{"NOT VERIFIED"} & \text{otherwise} \end{cases}$

Check\_CapSpacing2 = "VERIFIED"



## E. Shear Verification

### E1.Data recall (section B of chapter 1.04)



$diam_{\text{No}_{sh,\text{cap}}} = 0.5 \cdot \text{in}$	Diameter of cap shear GFRP reinforcement
$area_{\text{No}_{sh,\text{cap}}} = 0.2 \cdot \text{in}^2$	Area of cap shear GFRP reinforcement
$E_{f\text{No}_{sh,\text{cap}}} = 7.1 \times 10^3 \cdot \text{ksi}$	Modulus of elasticity of cap shear GFRP reinforcement
$f_{fu\text{No}_{sh,\text{cap}}} = 125.5 \cdot \text{ksi}$	Tensile strength of cap shear reinforcement for product certification as reported by GFRP manufacturer [AASHTO GFRP 2009, 2.6.1.2]
$f_{fd,\text{sh},\text{cap}} = 87.9 \cdot \text{ksi}$	Design strength of cap shear reinforcement considering reduction for service environment [AASHTO GFRP 2009, 2.6.1.2-1]
$\epsilon_{fu\text{No}_{sh,\text{cap}}} = 1.9 \cdot \%$	Tensile strain of cap shear reinforcement for product certification as reported by GFRP manufacturer [AASHTO GFRP 2009, 2.6.1.2]
$\epsilon_{fd\text{No}_{sh,\text{cap}}} = 1.3 \cdot \%$	Design strain of cap shear reinforcement reinforcement considering reduction for service environment [AASHTO GFRP 2009, 2.6.1.2]



### E2. Punching shear check



To calculate ultimate two-way shear load

Recall  $d_{f1,\text{cap}} = 27.4 \cdot \text{in}$

According to load analysis, the maximum reaction load at support is 447.5 kip

$P_{u,2w,\text{spt}} = 447.5 \cdot \text{kip}$

Also recall diameter of pile  $\phi_{\text{pile}}$

$$\phi_{\text{pile}} := 18 \text{ in}$$

Because the shear design begins at  $d_{\text{fl}}$  away from the side of pile. therefore the effective cap length in transverse direction is  $\phi_{\text{pile}} + 2d_{\text{fl, cap}}$

$$\phi_{\text{pile}} + 2d_{\text{fl, cap}} = 72.8 \text{ in}$$

Therefore, the top area of cap  $A_{\text{tp, cap}}$  is:

$$A_{\text{tp, cap}} := (\phi_{\text{pile}} + 2d_{\text{fl, cap}}) \cdot b_{\text{cap}} = 3.1 \times 10^3 \cdot \text{in}^2$$

From load analysis, the average load distributed in effective top area of cap  $q_{\text{ave}}$

$$q_{\text{ave, cap}} := \frac{(1.25 \cdot 9.2 \text{ klf} + 1.5 \cdot 0.5 \text{ klf} + 1.75 \cdot 9 \text{ klf})}{b_{\text{cap}}} = 8 \cdot \text{ksf}$$

The ultimate two-way shear load  $V_{\text{u, 2, spt}}$ .

$$V_{\text{u, 2w, cap}} := P_{\text{u, 2w, spt}} - (d_{\text{fl, cap}} + \phi_{\text{pile}})^2 \cdot q_{\text{ave, cap}} = 333.1 \cdot \text{kip}$$

The parameter of critical section for cap and pile  $b_{0, \text{cap}}$

$$b_{0, \text{cap}} := 4(\phi_{\text{pile}} + d_{\text{fl, cap}}) = 181.5 \cdot \text{in}$$

$$c_{\text{cap}} := k_{1, \text{cap}} \cdot d_{\text{fl, cap}} = 5.4 \cdot \text{in}$$

The shear strength of FRP reinforced two-way slab  $V_{\text{n, tw, cap}}$

[AASHTO GFRP 2009, 2.10.3.2.1-1]

$$V_{\text{n, 2w, cap}} := 0.32 \sqrt{f'_{\text{c, sub}} \cdot \text{ksi}} \cdot b_{0, \text{cap}} \cdot c_{\text{cap}} = 729.7 \cdot \text{kip}$$

Recall resistance factor for shear  $\phi_v$   $\phi_v = 0.75$

The ultimate shear strength

$$\phi_v \cdot V_{\text{n, 2w, cap}} = 547.3 \cdot \text{kip}$$

Check for two-way shear:

$$\text{CheckCapTwoWayShear} := \begin{cases} \text{"VERIFIED"} & \text{if } \phi_v \cdot V_{\text{n, 2w, cap}} \geq V_{\text{u, 2w, cap}} \\ \text{"REDESIGN"} & \text{otherwise} \end{cases}$$

CheckCapTwoWayShear = "VERIFIED"



### E3. Shear reinforcement



According to load analysis the maximum shear at  $d_{\text{fl, cap}}$  from the pile force  $V_{\text{d, cap}}$  is:

$$V_{\text{u, d, cap}} = 124 \cdot \text{kip}$$

The nominal shear resistance provide by concrete,  $V_c$

$$\text{Recall } b_{\text{cap}} = 42 \cdot \text{in}$$

[AASHTO GFRP 2009, 2.10.3.2.1-1]

$$V_{n,1w, \text{cap}} := 0.16 \sqrt{f'_{c, \text{sub}} \cdot \text{ksi} \cdot b_{\text{cap}} \cdot c_{\text{cap}}} = 84.4 \cdot \text{kip}$$

According to ASSHTO GFRP 2009 2.7.4.2, resistance reduction factor  $\phi_v$  for shear is 0.75

$$\phi_v = 0.75 \quad [\text{AASHTO GFRP 2009, 2.10.3.2.1-1}]$$

$$\phi_v \cdot V_{n,1w, \text{cap}} = 63.3 \cdot \text{kip}$$

Recall two-way shear strength

$$V_{n,2w, \text{cap}} = 729.7 \cdot \text{kip}$$

The shear strength provided by concrete can be computed:

$$V_{c, \text{cap}} := \min(V_{n,1w, \text{cap}}, V_{n,2w, \text{cap}}) = 84.4 \cdot \text{kip}$$

$$\phi_v \cdot V_{c, \text{cap}} = 63.3 \cdot \text{kip}$$

Check whether reinforcement for shear is required or not

$$\text{CheckShearReinforcement} := \begin{cases} \text{"SHEAR REINFORCEMENT REQUIRED"} & \text{if } V_{u,d, \text{cap}} \geq 0.5 \cdot \phi_v \cdot V_{c, \text{cap}} \\ \text{"NOT REQUIRED"} & \text{otherwise} \end{cases}$$

**CheckShearReinforcement = "SHEAR REINFORCEMENT REQUIRED"**

The required nominal shear resistance provided by shear reinforcement  $V_{f, \text{req}, \text{cap}}$  is:

$$V_{f, \text{req}, \text{cap}} := \frac{V_{u,d, \text{cap}}}{\phi_v} - V_{n,1w, \text{cap}} = 80.9 \cdot \text{kip} \quad [\text{AASHTO GFRP 2009, 2.10.3.1-1}]$$

Area of shear reinforcement with spacing  $s$ ,  $A_{fv, \text{cap}}$

$$\text{Recall } \text{diam}_{\text{No}_{\text{sh}, \text{cap}}} = 0.5 \cdot \text{in} \quad \text{area}_{\text{No}_{\text{sh}, \text{cap}}} = 0.2 \cdot \text{in}^2$$

The trial number of stirrup legs:

$$N_{fv, \text{cap}} := 4$$

$$A_{fv, \text{cap}} := N_{fv, \text{cap}} \cdot \text{area}_{\text{No}_{\text{sh}, \text{cap}}} = 0.8 \cdot \text{in}^2$$

Strength of the bent portion of a GFRP reinforcement  $f_{fb, \text{NO}4}$

$$f_{fb, \text{NO}4} := \min \left[ \left( 0.05 \cdot \frac{\text{diam}_{\text{No}_{\text{pr}, \text{cap}}}}{\text{diam}_{\text{No}_{\text{sh}, \text{cap}}}} + 0.3 \right) \cdot f_{fd, \text{sh}, \text{cap}}, f_{fd, \text{sh}, \text{cap}} \right] = 37.3 \cdot \text{ksi}$$

The design tensile strength for shear  $f_{fv}$

$$f_{fv, \text{cap}} := \min(0.004 \cdot E_{f, \text{No}_{\text{sh}, \text{cap}}}, f_{fd, \text{sh}, \text{cap}}) = 28.4 \cdot \text{ksi}$$

Spacing of Shear Reinforcement  $S_{v, \text{cap}}$

$$S_{v, \text{cap}} := \frac{A_{fv, \text{cap}} \cdot f_{fv, \text{cap}} \cdot d_{f1, \text{cap}}}{V_{f, \text{req}, \text{cap}}} = 7.5 \cdot \text{in}$$

Therefore, spacing  $S_{v, \text{cap}, \text{sl}}$  for shear reinforcement:

$$S_{v, \text{cap}, \text{sl}} := 9 \text{ in}$$



### Limit state check



Check for spacing:

Minimum Spacing for Cast-in-Place

$$S_{v, \text{min}} := \max\left(1.5 \cdot \text{diam}_{\text{No}_{\text{sh}, \text{cap}}}, 1.5 \text{ in}\right) = 1.5 \text{ in}$$

Maximum Spacing

$$S_{v, \text{max}} := \min(h_{\text{cap}}, b_{\text{cap}}, 12 \text{ in}) = 12 \text{ in}$$

$$\text{CheckCapShearSpacing} := \begin{cases} \text{"VERIFIED"} & \text{if } S_{v, \text{min}} \leq S_{v, \text{cap}, \text{sl}} \leq S_{v, \text{max}} \\ \text{"NOT VERIFIED"} & \text{otherwise} \end{cases}$$

CheckCapShearSpacing = "VERIFIED"

Check Shear Resistance Requirement:

Shear Resistance Provided by Reinforcement  $V_{f, \text{cap}}$

$$V_{f, \text{cap}} := A_{f_v, \text{cap}} \cdot f_{f_v, \text{cap}} \cdot \frac{d_{f2, \text{cap}}}{S_{v, \text{cap}, \text{sl}}} = 67.8 \cdot \text{kip}$$

Recall the required nominal shear resistance provided by shear reinforcement  $V_{f, \text{req}, \text{cap}}$ ,

$$V_{f, \text{req}, \text{cap}} = 80.9 \cdot \text{kip}$$

$$\text{CheckCapShearResistanceRequirement} := \begin{cases} \text{"VERIFIED"} & \text{if } V_{f, \text{cap}} \geq V_{f, \text{req}, \text{cap}} \\ \text{"NOT VERIFIED"} & \text{otherwise} \end{cases}$$

CheckCapShearResistanceRequirement = "NOT VERIFIED"

Check Minimum Shear Reinforcement

Minimum Shear Reinforcement with spacing 9 in  
[AASHTO GFRP 2009, 2.10.2.2.1-1]

$$A_{f_v, \text{min}, \text{cap}} := 0.05 \cdot b_{\text{cap}} \cdot \frac{S_{v, \text{cap}, \text{sl}}}{\frac{f_{f_v, \text{cap}}}{\text{ksi}}} = 0.7 \cdot \text{in}^2$$

$$\text{CheckCapMinVReinforcement} := \begin{cases} \text{"VERIFIED"} & \text{if } A_{f_v, \text{cap}} \geq A_{f_v, \text{min}, \text{cap}} \\ \text{"NOT VERIFIED"} & \text{otherwise} \end{cases}$$

CheckCapMinVReinforcement = "VERIFIED"

Check Maximum Shear Reinforcement

Maximum Shear Resistance provided by shear reinforcement  $V_{f,max, cap}$

[AASHTO GFRP 2009, 2.10.2.2.2-1]

$$V_{f,max, cap} := 0.25 \cdot \sqrt{f_{c,sub}} \cdot \text{ksi} \cdot b_{cap} \cdot d_{f2, cap} = 674.1 \cdot \text{kip}$$

$$\text{CheckCapMaxVReinforcement} := \begin{cases} \text{"VERIFIED"} & \text{if } V_{f,max, cap} \geq V_{f, cap} \\ \text{"NOT VERIFIED"} & \text{otherwise} \end{cases}$$

CheckCapMaxVReinforcement = "VERIFIED"

Use 4 legs #4 with spacing 9" in primary direction for shear reinforcement of cap.

Shear Reinforcement Detailing

Internal radius of the cap shear bent GFRP bar [AASHTO GFRP 2009, 5.6.4]

$$r_{bNo_{sh, cap}} = 2.1 \cdot \text{in}$$

If a tail length  $L_{thf, cap}$  is beyond 12 multiplied by diameter of shear reinforcement of cap, there is no significant slippage and no influence on the tensile strength of the stirrup leg.

$$L_{thf, cap, min} := 12 \cdot \text{diam}_{No_{sh, cap}} = 6 \cdot \text{in}$$

**F. Cap to Pile joint verification**

Recall the maximum force at support

$$P_{u, 2w, spt} = 447.5 \cdot \text{kip}$$

Check bearing of pile and cap

The maximum bearing load of pile top  $P_{bearing, pile}$

Recall resistance reduction factor for bearing  $\phi_{bearing}$

$$\phi_{bearing} := 0.65$$

$$P_{bearing, pile} := \phi_{bearing} \cdot 0.85 \cdot f_{c,sub} \cdot \text{Pile}_{size} \cdot \text{Pile}_{size} = 984.6 \cdot \text{kip}$$

The maximum bearing load of cap bottom  $P_{bearing, cap}$

$A_2$  is the area of the upper base of the largest frustum of a pyramid, cone, or tapered wedge contained wholly within the support and having its lower base equal to the loaded area. The sides of the pyramid, cone, or tapered wedge shall be sloped 1 vertical to 2 horizontal.

$$a_{A2} := 42 \text{in}$$

$$b_{A2} := 54 \text{in}$$

$$A_2 := a_{A2} \cdot b_{A2} = 2268 \cdot \text{in}^2$$

$$P_{\text{bearing.cap}} := \min \left( \phi_{\text{bearing}} \cdot 1.7 \cdot f_{c,\text{sub}} \cdot P_{\text{pile.size}} \cdot P_{\text{pile.size}}, \phi_{\text{bearing}} \cdot 0.85 \cdot f_{c,\text{sub}} \cdot P_{\text{pile.size}} \cdot P_{\text{pile.size}} \cdot \sqrt{\frac{A_2}{P_{\text{pile.size}} \cdot P_{\text{pile.size}}}} \right)$$

$$P_{\text{bearing.cap}} = 1969.1 \cdot \text{kip}$$

Check bearing strength of cap and bearing strength of pile. In joint design, the bearing strength of cap should be always larger than the bearing of pile in order to prevent the crashing of cap.

$$\text{Check\_Bearing\_of\_Cap} := \begin{cases} \text{"VERIFIED"} & \text{if } P_{\text{bearing.pile}} < P_{\text{bearing.cap}} \\ \text{"REDESIGN"} & \text{otherwise} \end{cases}$$

$$\text{Check\_Bearing\_of\_Cap} = \text{"VERIFIED"}$$

$$\text{CheckBearingAtJoint} := \begin{cases} \text{"NO DOWEL NEEDED"} & \text{if } P_{u,2w.spt} < P_{\text{bearing.pile}} < P_{\text{bearing.cap}} \\ \text{"REDESIGN"} & \text{otherwise} \end{cases}$$

$$\text{CheckBearingAtJoint} = \text{"NO DOWEL NEEDED"}$$



### G. Summary of Provided Reinforcement and Detailing

#### Negative moment region



$N_{o_{pr.cap}} = 10$  Bar number of primary reinforcement (top and bottom)

$N_{f_{des1.cap}} = 12$  Number of bars

$s_{f_{bar1.clr.cap}} = 1.9\text{-in}$  Clear spacing

$L_{d.neg.min.cap} = 2.3\text{ ft}$  Development length for negative moment region

$L_{sp.sl.neg.cap} = 123\text{-in}$  Splice length for negative moment region

Reinforcement Distribution for Negative Moment of Pile Cap

a) Edge Span (#10 GFRP Bars)

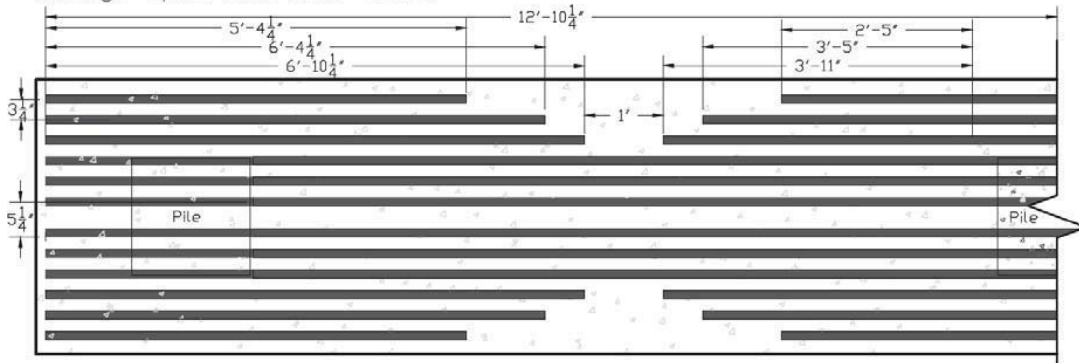

b) Interior Span (#10 GFRP Bars)

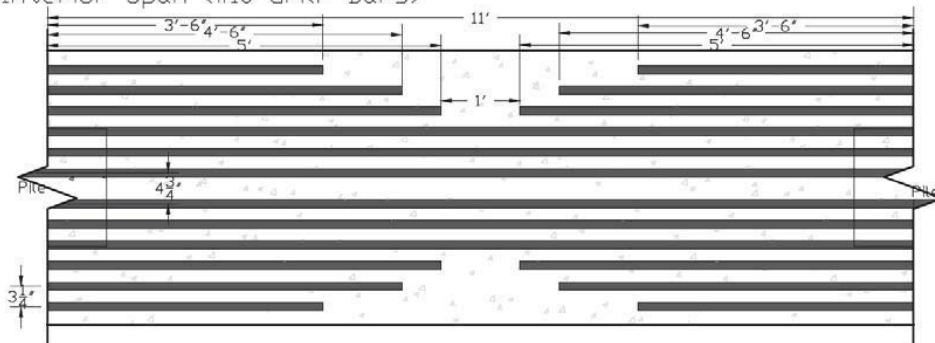

**Positive moment region**



$N_{o_{pr.cap}} = 10$  Bar number of primary reinforcement (top and bottom)

$N_{f_{des1.cap}} = 12$  Number of bars

$s_{f_{bar1.clr.cap}} = 1.9\text{-in}$  Clear spacing

$L_{d.pos.cap.sl} = 2.5\text{ ft}$  Development length for positive moment region

$L_{sp.sl.pos.cap} = 5.8\text{ ft}$  Splice length for negative moment region

Reinforcement Distribution for Positive Moment of Pile Cap  
 a).Edge Span (#10 GFRP Bars)

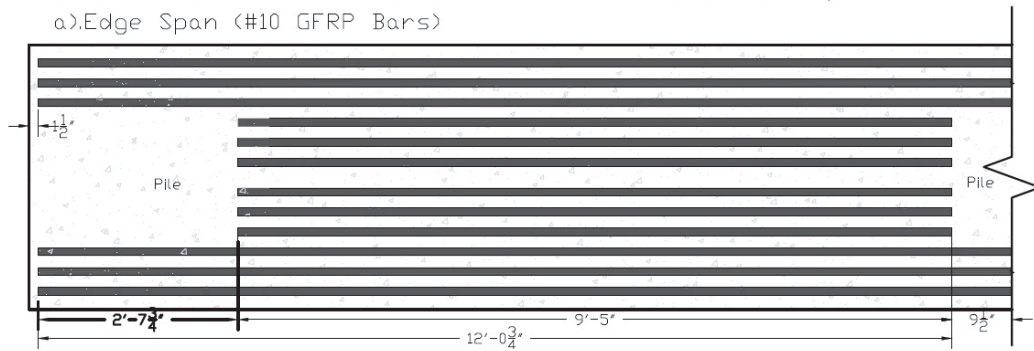

b).Interior Span (#10 GFRP Bars)

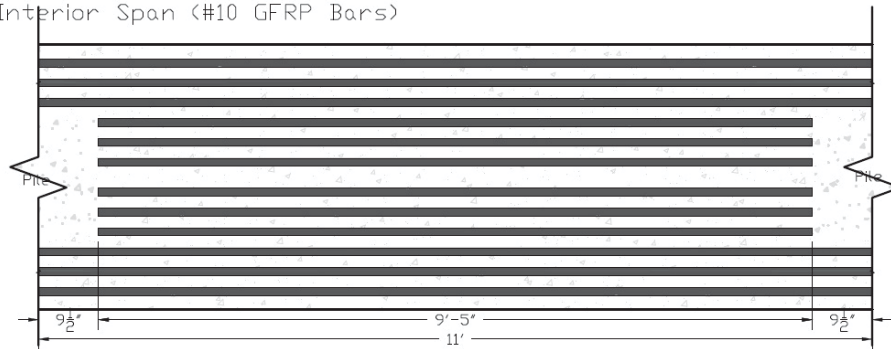



**Shear reinforcement**



Bar Number for 4 G7 U/C bars

$$N_{fv.cap} = 4$$

Spacing

$$S_{v.cap.sl} = 9 \cdot in$$

Pile Cap and Stirrup-Top View

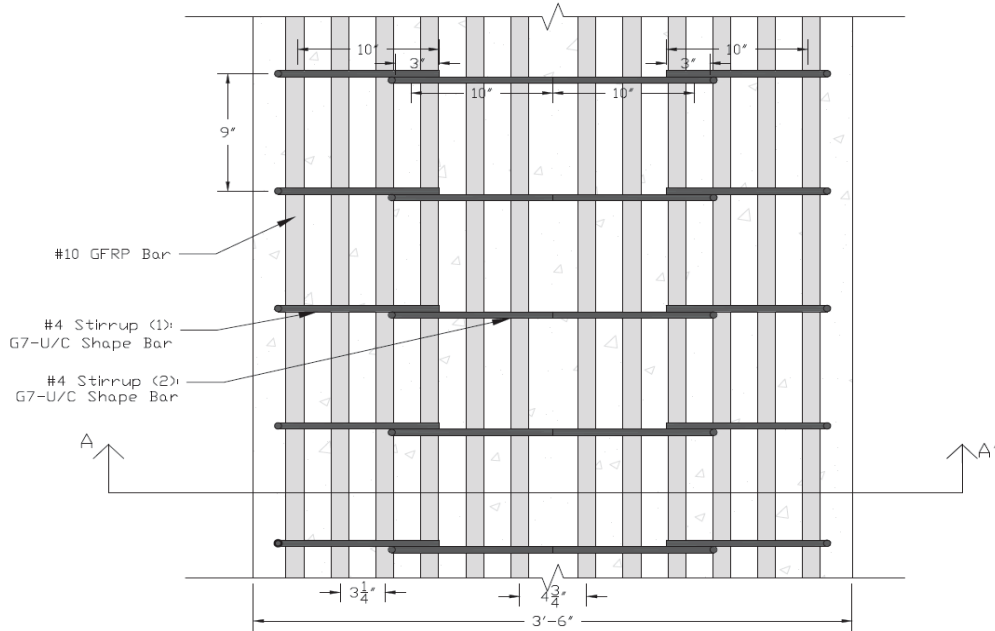

Pile Cap and Stirrups in Section A-A'

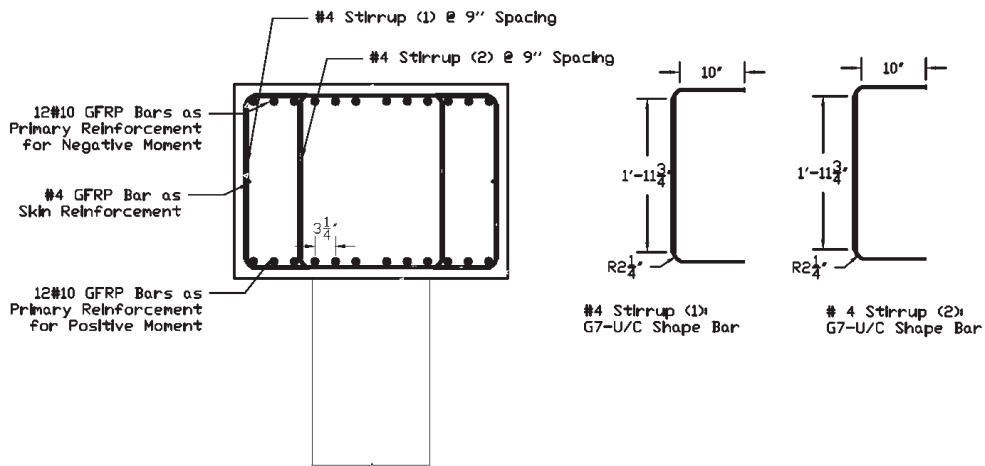



## SUBSTRUCTURE DESIGN

### Bent 2 Piles Vertical Load Design

---

#### References

➔ Reference:L:\LRFD\_Design\_Example\_#2A thesis\3.02.GFRP\_Cap\_Design.xmcd(R)

#### Description

This section provides the design of the piles for vertical loads (exclude lateral load design). For this design example, only the maximum loaded pile is evaluated.

<b>Page</b>	<b>Contents</b>
146	FDOT Criteria
147	A. Input Variables
148	B. Pile Tip Elevations for Vertical Load
	B1. Pile Capacities as per SPT97

**FDOT Criteria**

**Minimum Sizes [SDG 2015, 3.5.2]**

Use 18" square piling, except for extremely aggressive salt water environments.

**Spacing, Clearances and Embedment and Size [SDG 2015, 3.5.3]**

Minimum pile spacing center-to-center must be at least three times the least width of the deep foundation element measured at the ground line.

**Resistance Factors [SDG 2015, 3.5.5]**

The resistance factor utilizing SPT97 for piles under compression shall be...

$\phi_{SPT97} := 0.65$

**Minimum Pile Tip [SDG 2015, 3.5.7]**

The minimum pile tip elevation must be the deepest of the minimum elevations that satisfy lateral stability requirements for the three limit states. Since this bridge is not over water, scour and ship impact are not design issues. The design criteria for minimum tip elevation are based on vertical load requirements and lateral load analysis.

**Pile Driving Resistance [SDG 2015, 3.5.11]**

The Required Driving Resistance for an 18" square concrete pile must not exceed.....

$UBC_{FDOT\_18} := 300 \cdot \text{Ton}$

The Required Driving Resistance for an 24" square concrete pile must not exceed.....

$UBC_{FDOT\_24} := 450 \cdot \text{Ton}$

**A. Input Variables**

Maximum Strength I pile reaction  $R_{Strength1} = 447 \cdot \text{kip}$  or  $R_{Strength1} = 223 \cdot \text{Ton}$

Required driving resistance (RDR).....  $RDR = UBC = \frac{\text{Factored Design Load} + \text{Net Scour} + \text{Downdrag}}{\phi}$

Using variables defined in this example.....  $UBC := \frac{R_{Strength1}}{\phi_{SPT97}}$

$UBC = 343.8 \cdot \text{Ton}$

This value should not exceed the limit specified by FDOT.....  $UBC_{FDOT\_18} = 300 \cdot \text{Ton}$

Since the RDR value is exceeded, the consultant needs to evaluate the following costs:

1. Reducing the pile spacing from 11' and adding an extra pile or two
2. Utilizing 24" diameter piles.

For purposes of the design example, pile driving vibrations are not an issue, neither is accessibility to the job site for pile driving equipment; therefore, 24" square piles will be utilized,  $UBC_{FDOT\_24} = 450 \cdot \text{Ton}$ .

## B. Pile Tip Elevations for Vertical Load

### B1. Pile Capacities as per SPT97

The Static Pile Capacity Analysis Program, SPT97 NT v1.5 dated 6/2/00, was utilized to determine the pile capacity. Using boring data, the program can analyze concrete piles, H-piles, pipe piles, and cylinder piles. It is available at the following FDOT website:

<http://www11.myflorida.com/structures/programs/spt97setup.exe>

For this design example, the boring data is based on Example2 in the program, which is part of the install package.

The screenshot shows the SPT97 Windows Application interface. The title bar reads "C:\fdot\_str\programs\spt97\example2.in - Spt97 Windows Application". The menu bar includes "File", "View", "SPT97", "Window", and "Help". The toolbar contains icons for file operations and a "RUN" button. The main window is divided into several sections:

- Measurement Units:** Radio buttons for "English Units" (selected) and "Metric Units".
- Analysis Type:** Radio buttons for "Specific Pile Length" and "Range of Pile Length:" (selected).
- Project Information:** Text boxes for "Project Number" (72002-1401), "Job Name" (I-95/I-295/SR-9A Intercha), "Submitting Engineer:" (Peter Lai), "Date of Boring:" (12/18/95), "Boring Number:" (BS-1), "Station Number and Offset:" (26+69, 15m LT BL SR), and "Water Table Height relative to Ground Surface" (0).
- Pile Data:** Radio buttons for "Square Concrete" (selected), "Round Concrete", "Steel Pipe Pile", "Steel H-Pile", and "Cylinder Pile".
- Unit Weight (lb/ft3):** Text box with value 150.108.
- Ground Surface Elevation:** Text box with value 8.497.
- Pile Lengths (ft):** Text boxes for "Minimum Pile Length (ft)" (3.281), "Maximum Pile Length (ft)" (65.617), and "Pile Length Increment (ft)" (3.281).
- Pile Widths (in):** A list of five text boxes with values 18, 24, 0, 0, and 0.
- Buttons:** "Boring Log" button.

The status bar at the bottom shows "Ready" and a "NUM" indicator.

The following picture shows the boring log entries in Example2.in.

Entries 1-45			Entries 46-90			Entries 91-135			Entries 136-180			Entries 181-225		
Depth (feet)	Blow Count	Soil Type	Depth (feet)	Blow Count	Soil Type	Depth (feet)	Blow Count	Soil Type	Depth (feet)	Blow Count	Soil Type	Depth (feet)	Blow Count	Soil Type
1	0.984	3	16	38.55	27	31	77.756	45	2					
2	3.576	3	17	41.01	80	32	78.543	30	2					
3	5.971	3	18	43.602	72	33	80.381	100	2					
4	8.53	2	19	45.997	49	34	80.709	0	0					
5	11.122	3	20	48.556	60	35	0	0	0					
6	13.451	3	21	51.148	56	36	0	0	0					
7	16.076	3	22	53.51	20	37	0	0	0					
8	18.537	3	23	56.037	36	38	0	0	0					
9	21.063	3	24	58.53	35	39	0	0	0					
10	23.556	3	25	63.583	42	40	0	0	0					
11	26.083	3	26	63.976	81	41	0	0	0					
12	28.543	3	27	66.109	79	42	0	0	0					
13	30.971	3	28	68.57	50	43	0	0	0					
14	33.465	3	29	70.866	100	44	0	0	0					
15	35.958	3	30	73.425	100	45	0	0	0					

**Soil Type Legend**

- 1 - Plastic Clays
- 2 - Clay, Silt, Sand Mix, Silts and Marls
- 3 - Clean Sands
- 4 - Soft Limestone, Very Shelly Sands
- 5 - Void (No Capacity)

Show Advanced Soil Types

Note: Last entry must have non-zero depth, blow count zero, and soil type zero.

Insert Entry  
Delete Entry  
OK Cancel

Recall that the ultimate bearing capacity, UBC, is given by.....

$$UBC = \frac{\text{Factored Design Load} + \text{Net Scour} + \text{Downdrag}}{\phi}$$

In this design example, net scour and downdrag are zero, so the UBC is.....

$$UBC = 343.8 \cdot \text{Ton}$$

The program was executed, and the output can be summarized as follows:

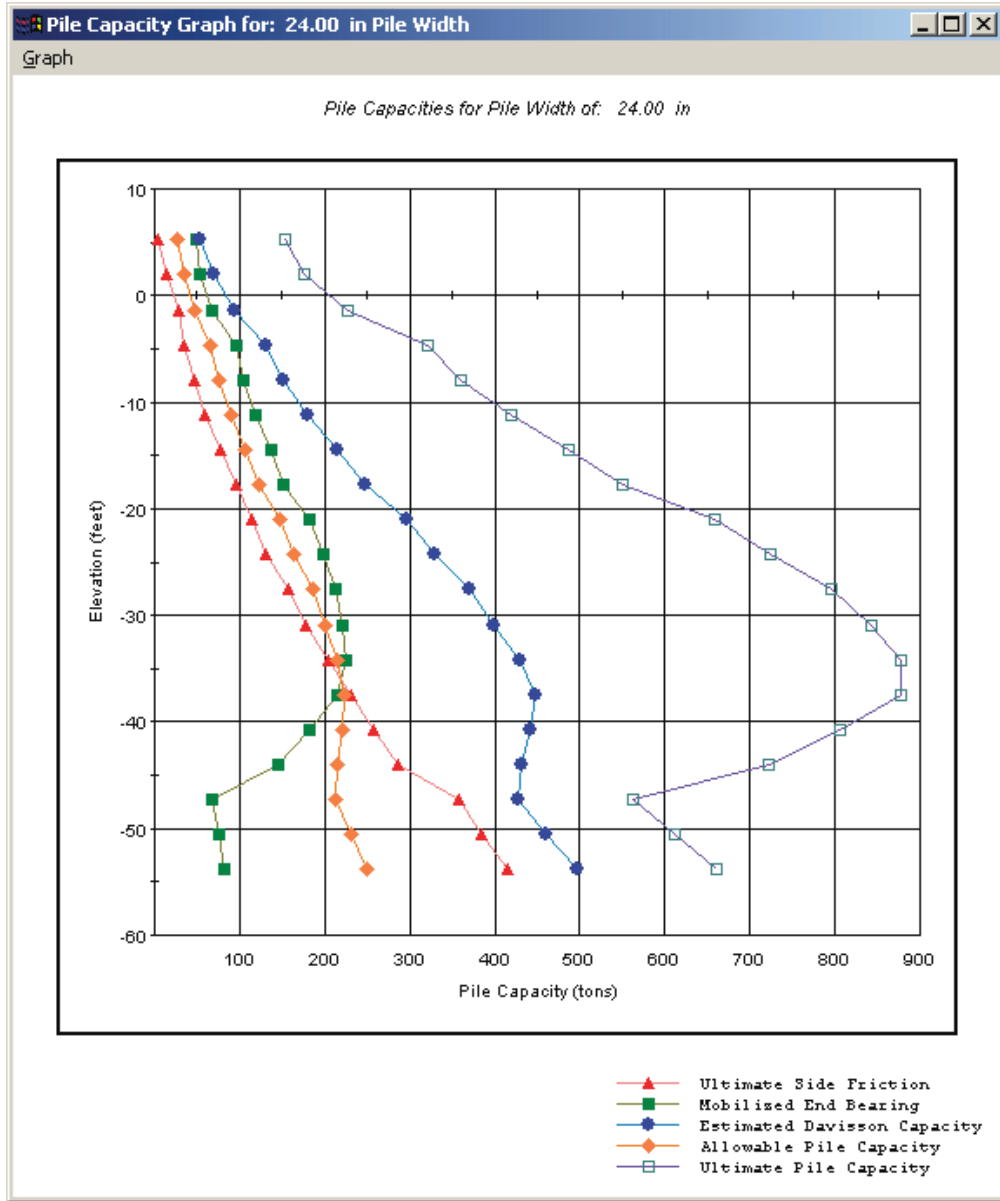

D. PILE CAPACITY VS. PENETRATION

=====

TEST PILE LENGTH (FT)	PILE TIP ELEV (FT)	ULTIMATE SIDE FRICTION (TONS)	MOBILIZED END BEARING (TONS)	ESTIMATED DAVISSON CAPACITY (TONS)	ALLOWABLE PILE CAPACITY (TONS)	ULTIMATE PILE CAPACITY (TONS)
32.8	-24.3	131.43	197.43	328.86	164.43	723.73
36.1	-27.6	157.91	212.88	370.79	185.39	796.55

A lateral load analysis may require the pile tip elevations to be driven deeper for stability purposes. This file only evaluates the vertical load requirements based on the boring capacity curves.

Calculate the pile length required.....

$$\text{pile}_{\text{length}} := (\text{UBC} - 328.96 \cdot \text{Ton}) \cdot \left( \frac{36.1 \cdot \text{ft} - 32.8 \cdot \text{ft}}{370.79 \cdot \text{Ton} - 328.86 \cdot \text{Ton}} \right) \dots + 32.8 \cdot \text{ft}$$

pile<sub>length</sub> = 34 ft

Calculate the pile tip elevation required.....

$$\text{pile}_{\text{tip}} := (\text{UBC} - 328.96 \cdot \text{Ton}) \cdot \left( \frac{-27.6 \cdot \text{ft} - -24.3 \cdot \text{ft}}{370.79 \cdot \text{Ton} - 328.86 \cdot \text{Ton}} \right) + -24.3 \cdot \text{ft}$$

pile<sub>tip</sub> = -25.5 ft

...based on the Estimated Davisson pile capacity curve given above, the pile lengths for vertical load will require a specified Tip Elevation = -25.5 ft. Therefore, the pile in the ground length is 34 ft.

All piles at the Intermediate Bent will be specified the same.

▢ Defined Units



**APPENDIX B:**

**CR490A BRIDGE OVER HALLS RIVER:  
DRAWINGS AND DESIGN CALCULATIONS**

**CONSTRUCTION SPECIFICATIONS:**  
Florida Department of Transportation Standard Specifications for Road and Bridge Construction (2015 Edition) as amended by contract documents.

**DESIGN SPECIFICATIONS:**  
- American Association of State Highway and Transportation Officials (AASHTO), LRFD Bridge Design Specifications (7th Edition) and approved in terms as specified in the Structural Guidelines.  
- FDOT Structures Manual (January 2014) and subsequent Structures Design Bulletin.  
- FDOT Plans Preparation Manual (January 2014).

**DESIGN LOADING:**  
DEAD LOADS:  
Unit Weight of Reinforced Concrete 150 pcf  
(including reinforcement)  
Traffic Railing Barrier 420 pcf  
Prestressing Bedding 30 pcf  
Guardrail (Type II) 2 pcf  
Design does not include an allowance for Future Wearing Surface.

**LIVE LOADS:**  
HL-93 Loading with impact.

**WIND LOADS:**  
Wind loads are in accordance with AASHTO, Section 3.8, and with the Structures Design Guidelines, Section 2.4.

**SEISMIC LOADS:**  
The minimum Bearing Support Length is determined in accordance with AASHTO, Section 4.7.4.4. No Seismic Forces are applied in accordance with the Structures Design Guidelines, Section 2.3.

**TEMPERATURE EFFECTS:**  
Structure Material Mean Rise From Mean Temperature (°F) Range  
Concrete 70 70 +35 -70

**COEFFICIENT OF THERMAL EXPANSION:** 0.000006 per °F.

**DESIGN METHOD:**  
Load and Resistance Factor Design Method (LRFD) for all elements.

**ENVIRONMENT:**  
Superstructure - Extremely Aggressive  
Substructure - Extremely Aggressive  
Water: Resistivity = 240 ohm-cm & Sulfates = 251 ppm

**CONCRETE:**

Class	Minimum 28-Day Compressive Strength (f'c) (psi)	Location of Concrete in Structure
IV	5,500	Barriers
IV (Bridge Deck)	5,500	Bridge Deck, Approach Slabs
V (Special)	6,000	Prestressed Joints
V (Special)	6,000	High Strength Beams
IV	5,500	ICP Substructure

**CONCRETE COVER**  
Concrete cover shown in the plans do not include placement and fabrication tolerances unless otherwise shown as "Minimum Cover". See FDOT Standard Specifications 415 for allowable tolerances.

**CHAMFERS:**  
Provide 1/4" Chamfer on all exposed edges, except as otherwise noted.

**VERTICAL DATUM:** NGVD 29.

**BRIDGE FLOOR GROOVING:**  
Bridge Floor and Approach Slab surfaces shall be grooved in accordance with Section 400-15.2-5.6 of the Florida Department of Transportation Standard Specifications.

**DESIGNATIONS:**  
C.M. = Clear  
U.O.M. = Unless otherwise noted  
T.O.B. = Top of Backwall  
F.F.B.W. = Front Face of Backwall

**REINFORCING STEEL:**  
All reinforcing steel shall be ASTM A615, Grade 60. All dimensions pertaining to locations of reinforcing are to centerline of bars except where the Clear dimension is shown to face of concrete.

**PRESTRESSING STRANDS FOR PILES:**  
Strands for Prestressed Piles shall meet the requirements detailed in FDOT Developmental Design Standard Drawings, Index No. D22600.

**MAINTENANCE OF TRAFFIC:**  
For Maintenance of Traffic see Roadway Plans.

**UTILITIES:**  
The responsibility of the contractor to uncover and verify the location of the existing utilities in the vicinity of pile driving operation. Unless directed otherwise by the Engineer, existing utilities must be protected during construction by the Contractor.  
For plan locations of existing utilities, see Plan and Elevation sheets(s). Locations of utilities are shown in the plans are approximate.  
For disposition of utilities, see the Utility Adjustment sheets(s) in the Roadway Plans.

**SCOUR:**  
Scour Analysis was considered for the Pile Foundation Design.

**JOINTS IN CONCRETE:**  
Construction Joints will be permitted only at locations indicated in the plans. Additional Construction Joints or alterations to those shown shall require approval of the Engineer. All contacting surfaces shall be coated with an approved epoxy bonding compound adjacent to existing concrete. The epoxy bonding compound shall be applied in a manner that minimizes the elapsed time between application and the casting of the new concrete. The use of other methods not utilizing epoxy bonding compound will require the prior approval of the Engineer.

**PHASING OF WORK:**  
Pile phasing and progression of the work shall conform with the Traffic Control Plans located in the Roadway Plans and the notes on the Construction Sequence drawings.

**EXPANSION JOINTS:**  
All Expansion Joints shall be installed after the Superstructure Cast-in-Place Concrete is cured and Deck Profiling is complete for the entire bridge.

**DECK SCREEDING:**  
Screed the riding surface of the Bridge Deck and Approach slabs to achieve the Finish Grade Elevations shown in the plans. Account for theoretical deflections due to weight, test casting sequence, deck forming systems, construction loads, overlays and temporary shoring, etc. as required.

**STAY-IN-PLACE DECK FORMS:**  
Design includes allowance for 20%st over the projected plan area of the Form Forms for the unit weight. Stay-in-place forms are not allowed at deck cantilevers.

**BRIDGE NAME:**  
Place the following bridge name on the traffic railing in accordance with the Traffic Railing Design Standards:  
Bridge No. 024054 C.R. 490A over Halls River.

**PLAN DIMENSIONS:**  
All dimensions in these plans are measured in feet either horizontally or vertically unless otherwise noted.

**EXISTING BRIDGE:**  
Dimension Verification: Unless otherwise noted, the dimensions, elevations and intersecting angles shown are based on the information as detailed in the Original Construction Plans of the existing bridges and may not represent as-built conditions. It is the Contractor's responsibility to verify this data before beginning construction and notify the Engineer of any discrepancies.

**GENERAL NOTES**  
CR 490A (W. HALLS RIVER ROAD) OVER HALLS RIVER

**REVISIONS**

DATE	BY	DESCRIPTION	DATE	BY	DESCRIPTION

**BRIDGE NO. 024054**

STATE OF FLORIDA  
DEPARTMENT OF TRANSPORTATION  
COUNTY: CITRUS  
PROJECT/ROUTE: CR 490A

PROJECT NO. SHEET NO.  
B-2

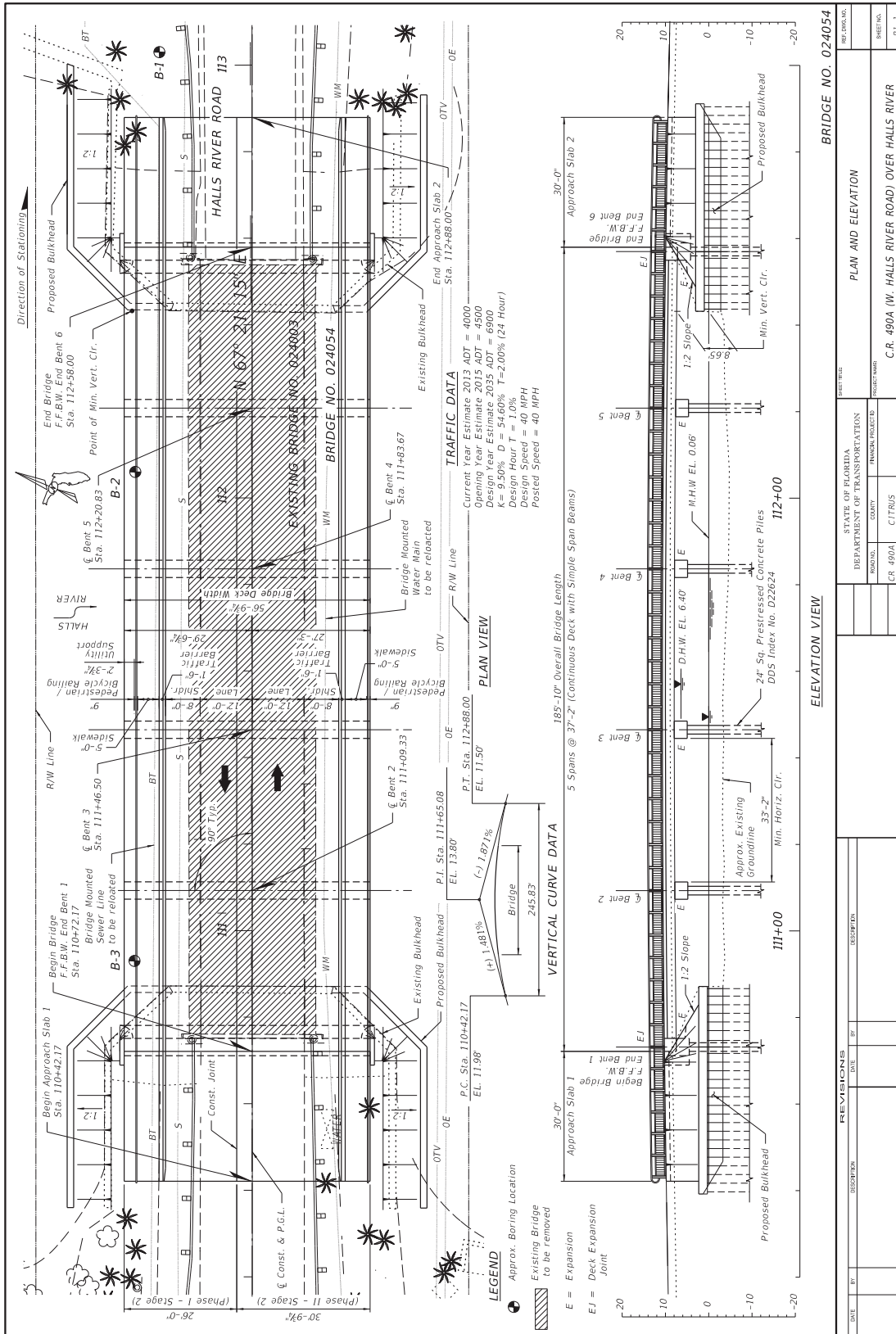

DATE	BY	DESCRIPTION

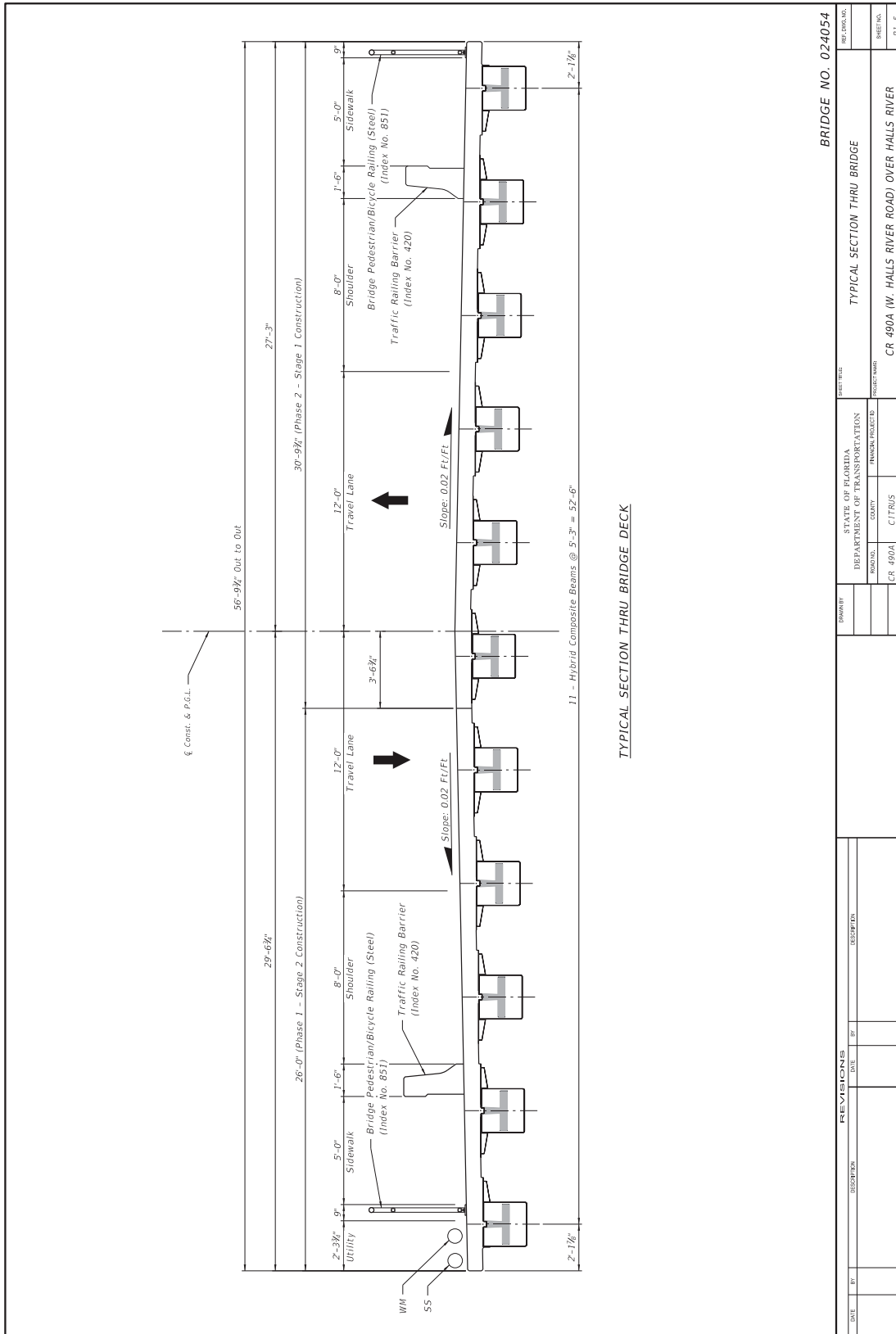

DATE		BY		DESCRIPTION		DRAWING		STATE OF FLORIDA		SHEET TITLE		SHEET NO.	
								DEPARTMENT OF TRANSPORTATION		TYPICAL SECTION THRU BRIDGE		81-5	
								ROAD NO. CR 490A		COUNTY CITRUS		PROJECT/PHASE CR 490A (W. HALLS RIVER ROAD) OVER HALLS RIVER	
								BRIDGE NO. 024054					





**FLORIDA DEPARTMENT OF TRANSPORTATION  
UNIVERSITY OF MIAMI**

PROJECT: *CR 490A over Halls river Bridge Replacement*  
SUBJECT: *Deck Design*

**References (links to other Mathcad files)**

- ☞ Reference:C:\Users\Angiolo\Desktop\CR490 A thesis\1.03.Design\_Parameters (1).xmcd(R)
- ☞ Reference:C:\Users\Angiolo\Desktop\CR490 A thesis\1.04.Material\_Properties.xmcd(R)
- ☞ Reference:C:\Users\Angiolo\Desktop\CR490 A thesis\2.01.Deck\_Design\_Loads.xmcd(R)

**Description**

This section provides the design for the GFRP-reinforced superstructure Deck

<b>Page</b>	<b>Contents</b>
1	A. Input Variables
3	B. Design of Primary Reinforcement
	B1. Data Recall
	B2. Select Primary Reinforcement and Limits
	B3. Negative Moment Region - Flexural Strength at Support
	B4. Development Length at Support
	B5. Positive Moment Region - Flexural Strength at Middle Span
	B6. Development Length at Middle Span
	B7. Reinforcement Splices
11	C. Shear Verification
11	D. Crack Width Verification
	C1. Data Recall
	C2. Support
	C3. Middle Span
14	E. Secondary Reinforcement
	E1.Data Recall
	E2.Reinforcement Distribution
16	F. Shrinkage and Temperature Reinforcement
	F1.Data Recall
	F2.Shrinkage and Temperature Reinforcement
17	G. Deflection Verification
20	H. Overhang Reinforcement
21	I. Summary of Provided Reinforcement and Detailing

## A. Input Variables

Maximum positive moment

Service  $M_{\text{pos}} := M_{\text{serviceI.pos}} = 5 \cdot \text{kip} \cdot \text{ft}$

Strength  $M_{\text{r.pos}} := M_{\text{strengthI.pos}} = 8.5 \cdot \text{kip} \cdot \text{ft}$

Live Load Only  $M_{\text{sPos}} := M_{\text{LL.pos}}$   $M_{\text{sPos}} = 4.7 \cdot \text{kip} \cdot \text{ft}$

Maximum negative moment

Service  $M_{\text{neg}} := M_{\text{serviceI.neg}} = 2.9 \cdot \text{kip} \cdot \text{ft}$

Strength  $M_{\text{r.neg}} := M_{\text{strengthI.neg}} = 4.9 \cdot \text{kip} \cdot \text{ft}$

Live Load Only  $M_{\text{sNeg}} := M_{\text{LL.neg}}$   $M_{\text{sNeg}} = 2.6 \cdot \text{kip} \cdot \text{ft}$

$c_{\text{cov}} := 1.5 \text{in}$  concrete clear cover

## B. Design of Primary Reinforcement

### B1.Data recall (section B of chapter 1.04)



$N_{o_{pr.slab}} = 6$	Deck primary reinforcement bar number.
$diam_{N_{o_{pr.slab}}} = 0.75 \cdot \text{in}$	Diameter of deck primary GFRP reinforcement
$area_{N_{o_{pr.slab}}} = 0.44 \cdot \text{in}^2$	Area of deck primary GFRP reinforcement
$E_{f.No6} := 7000 \text{ksi}$	Modulus of elasticity of deck primary GFRP reinforcement REDEFINED
$f_{fu.No6} := 100 \text{ksi}$	Tensile strength of deck primary reinforcement for product certification as reported by GFRP manufacturer [AASHTO GFRP 2009, 2.6.1.2] REDEFINED
$f_{fd.pr.slab} := (f_{fu.No6} \cdot C_e) = 70 \cdot \text{ksi}$	Design strength of deck primary reinforcement considering reduction for service environment [AASHTO GFRP 2009, 2.6.1.2-1]
$\epsilon_{fuNo_{pr.slab}} = 1.4\%$	Tensile strain of deck primary reinforcement for product certification as reported by GFRP manufacturer [AASHTO GFRP 2009, 2.6.1.2]
$\epsilon_{fdNo_{pr.slab}} = 1\%$	Design strain of deck primary reinforcement reinforcement considering reduction for service environment [AASHTO GFRP 2009, 2.6.1.2]



### B2. Select primary reinforcement and limits



#### Preliminary GFRP reinforcement

The failure mode depends on the amount of FRP reinforcement. If  $\rho_f$  is larger than the balanced reinforcement ratio,  $\rho_{fb}$ , then concrete crushing is the failure mode. If  $\rho_f$  is smaller than the balanced reinforcement ratio,  $\rho_{fb}$ , then FRP rupture is the failure mode.

[AASHTO GFRP 2009, 2.7.4.2-2]

$$\rho_{fb1.slab} := 0.85 \beta_{1.super} \cdot \frac{f_{c.super}}{f_{fd.pr.slab}} \cdot \frac{E_{f.No6} \cdot \epsilon_{cu}}{E_{f.No6} \cdot \epsilon_{cu} + f_{fd.pr.slab}} = 0.0119$$

The effective reinforcement depth

$$d_{f1.slab} := t_{slab} - c_c - \frac{diam_{N_{o_{pr.slab}}}}{2} = 6.13 \cdot \text{in}$$

This reinforcement ratio corresponds to an area of:

$$A_{f\_req1.slab} := \rho_{fb1.slab} \cdot b_{slab} \cdot d_{f1.slab} = 0.88 \cdot \text{in}^2 \text{ per foot width}$$

The corresponding number of GFRP bars is:



$$N_{f\_req1.slab} := \frac{A_{f\_req1.slab}}{area_{No_{pr.slab}}} = 2$$

The corresponding spacing is:

$$s_{f\_req1.slab} := \frac{b_{slab}}{N_{f\_req1.slab}} = 6 \cdot \text{in}$$

The trial number of GFRP bars is:

$$N_{f\_bar1.slab} := 2.4$$

Therefore, the following bar spacing is selected:

$$s_{f\_bar1.slab} := \frac{b_{slab}}{N_{f\_bar1.slab}} = 5 \cdot \text{in}$$

The minimum required clear bar spacing is:

$$s_{f\_min1.slab} := \max(1.5 \cdot \text{in}, 1.5 \cdot \text{diam}_{No_{pr.slab}}) = 1.5 \cdot \text{in}$$

The bar clear spacing is:  $s_{f\_bar1.slab} - \text{diam}_{No_{pr.slab}} = 4.3 \cdot \text{in}$

$$\text{Check\_BarSpacing1} := \begin{cases} \text{"VERIFIED"} & \text{if } s_{f\_bar1.slab} - \text{diam}_{No_{pr.slab}} \geq s_{f\_min1.slab} \\ \text{"TOO MANY BARS"} & \text{otherwise} \end{cases}$$

$$\text{Check\_BarSpacing1} = \text{"VERIFIED"}$$

The area of FRP reinforcement is:

$$A_{f1.slab} := N_{f\_bar1.slab} \cdot area_{No_{pr.slab}} = 1.06 \cdot \text{in}^2$$

The FRP reinforcement ratio is:

$$\rho_{f1.slab} := \frac{A_{f1.slab}}{b_{slab} \cdot d_{f1.slab}} = 0.0144$$

note:  $\rho_{f1.slab} < \rho_{fb1.slab}$ . Failure initiated by the concrete. Therefore  $f_{f1.slab} < f_{fd.pr.slab} = 63 \text{ksi}$

#### Limit for Reinforcement-Minimum Reinforcement

[AASHTO GFRP 2009, 2.9.3.3-1]

$$A_{f.min.slab} := \max(0.33 \text{ksi}, 0.16 \cdot \sqrt{f_{c.super} \cdot \text{ksi}}) \cdot \frac{b_{slab} \cdot d_{f1.slab}}{f_{fd.pr.slab}} = 0.4 \cdot \text{in}^2$$

$$\text{Check\_FlexureMinReinforcement} := \begin{cases} \text{"VERIFIED"} & \text{if } A_{f1.slab} \geq A_{f.min.slab} \\ \text{"NOT VERIFIED"} & \text{otherwise} \end{cases}$$

$$\text{Check\_FlexureMinReinforcement} = \text{"VERIFIED"}$$

The slab using GFRP is chosen to be over-reinforced, which means that failure of the component is initiated by crushing of the concrete. The strength reduction factor  $\phi_{f\_bar1.slab}$  is:

[AASHTO GFRP 2009, 2.9.2.1]

$$\phi_{f\_bar1.slab} := \begin{cases} 0.55 & \text{if } \rho_{f1.slab} \leq \rho_{fb1.slab} \\ 0.3 + 0.25 \cdot \frac{\rho_{f1.slab}}{\rho_{fb1.slab}} & \text{if } \rho_{fb1.slab} \leq \rho_{f1.slab} \leq 1.4 \cdot \rho_{fb1.slab} \\ 0.65 & \text{if } \rho_{f1.slab} \geq 1.4 \cdot \rho_{fb1.slab} \end{cases} = 0.6$$



### B3. Negative moment region - flexural strength at support



$N_{o\_pr.slab} = 6$	Deck primary reinforcement bar number.
$diam_{N_{o\_pr.slab}} = 0.75 \cdot \text{in}$	Diameter of deck primary GFRP reinforcement
$area_{N_{o\_pr.slab}} = 0.44 \cdot \text{in}^2$	Area of deck primary GFRP reinforcement
$N_{f\_bar1.slab} = 2.4$	Number of GFRP bars per foot width for negative moment
$A_{f1.slab} = 1.1 \cdot \text{in}^2$	Area of GFRP bars per foot width for negative moment
$M_{r,neg} = 4.9 \cdot \text{kip} \cdot \text{ft}$	Maximum negative moment demand
$f_{fd.pr.slab} = 70 \cdot \text{ksi}$	Design strength of deck primary reinforcement considering reduction for service environment

The maximum tensile stress in the GFRP is computed:

[AASHTO GFRP 2009, 2.9.3.1-1]

$$f_{f1.slab} := \begin{cases} \sqrt{\frac{[(E_f \cdot N_{o6}) \cdot \epsilon_{cu}]^2}{4} + \frac{0.85 \beta_{1.super} \cdot f_{c.super}}{\rho_{f1.slab}} E_f \cdot N_{o6} \cdot \epsilon_{cu} - 0.5 (E_f \cdot N_{o6} \cdot \epsilon_{cu})} & \text{if } \rho_{f1.slab} \geq \rho_{fb1.slab} \\ f_{fu} & \text{otherwise} \end{cases}$$

$f_{f1.slab} = 62.9 \cdot \text{ksi}$  effective stress

$f_{fd.pr.slab} = 70 \cdot \text{ksi}$  design stress

$f_j$  cannot exceed  $f_{jd}$ , therefore, the following has to be checked:

$$\text{CheckMaxStress1} := \begin{cases} \text{"VERIFIED"} & \text{if } f_{f1.slab} \leq f_{fd.pr.slab} \\ \text{"REDUCE BAR SPACING OR INCREASE BAR SIZE"} & \text{otherwise} \end{cases}$$

CheckMaxStress1 = "VERIFIED"

The stress-block depth is computed as per Eq.2.9.3.2.2-2 or Eq.2.9.3.2.2-4 whether  $\rho_f > \rho_{fb}$  or  $\rho_f < \rho_{fb}$ , respectively.

$$a_{f1.slab} := \frac{A_{f1.slab} \cdot f_{f1.slab}}{0.85 \cdot f_{c.super} \cdot b_{slab}} = 1.19 \cdot \text{in} \quad [\text{AASHTO GFRP 2009, 2.9.3.2.2-2}]$$

Neutral axis depth  $c_b$  at balanced strain conditions:

$$c_{b1.slab} := \left( \frac{\epsilon_{cu}}{\epsilon_{cu} + \epsilon_{fdNo.pr.slab}} \right) \cdot d_{f1.slab} = 1.4 \cdot \text{in} \quad [\text{AASHTO GFRP 2009, 2.9.3.2.2-4}]$$

The nominal moment capacity is: [AASHTO GFRP 2009, 2.9.3.2.2-1, 2.9.3.2.2-3]

$$M_{n\text{AASHTO}_1.slab} := \begin{cases} A_{f1.slab} \cdot f_{f1.slab} \cdot \left( d_{f1.slab} - \frac{a_{f1.slab}}{2} \right) & \text{if } \rho_{f1.slab} \geq \rho_{fb1.slab} \\ A_{f1.slab} \cdot f_{f1.slab} \cdot \left( d_{f1.slab} - \frac{\beta_{1.super} \cdot c_{b1.slab}}{2} \right) & \text{otherwise} \end{cases}$$

$$M_{n\text{AASHTO}_1.slab} = 30.7 \cdot \text{kip} \cdot \text{ft}$$



Recall the strength reduction factor for slab:

[AASHTO GFRP 2009, 2.12.1.2.1]

$$\phi_{f\_bar1.slab} = 0.6$$

The design flexural strength is computed as:

$$\phi_{f\_bar1.slab} \cdot M_{n\text{AASHTO}_1.slab} = 19 \cdot \text{kip} \cdot \text{ft}$$

Recall  $M_{r.neg} = 4.9 \cdot \text{kip} \cdot \text{ft}$

$$\text{Check\_SlabFlexureAASHTO}_1 := \begin{cases} \text{"VERIFIED"} & \text{if } \phi_{f\_bar1.slab} \cdot M_{n\text{AASHTO}_1.slab} \geq M_{r.neg} \\ \text{"NOT VERIFIED"} & \text{otherwise} \end{cases}$$

Check\_SlabFlexureAASHTO\_1 = "VERIFIED"



#### B4. Development length at support



At least 1/3 of the total tension reinforcement provided for negative moment at a support shall have an embedment length  $L_{d.neg.min}$  beyond the point of inflection as follows:

[AASHTO GFRP 2009, 2.12.1.2.1]

$$L_{d.neg.min} := \max\left(d_{f1.slab}, 12 \cdot \text{diam}_{No_{pr.slab}}, 0.0625 \cdot L_{span}\right) = 2.3 \cdot \text{ft}$$



### B5. Positive moment region - flexural strength at middle span



$N_{o_{pr.slab}} = 6$	Deck primary reinforcement bar number.
$diam_{No_{pr.slab}} = 0.75 \cdot \text{in}$	Diameter of deck primary GFRP reinforcement
$area_{No_{pr.slab}} = 0.44 \cdot \text{in}^2$	Area of deck primary GFRP reinforcement
$N_{f\_bar1.slab} = 2.4$	Number of GFRP bars per foot width for positive moment
$A_{f2.slab} := A_{f1.slab} = 1.1 \cdot \text{in}^2$	Area of GFRP bars per foot width for positive moment
$d_{f2.slab} := d_{f1.slab} = 6.1 \cdot \text{in}$	The effective reinforcement depth
$S_{f\_bar2.slab} := s_{f\_bar1.slab} = 5 \cdot \text{in}$	The reinforcing spacing
$M_{r.pos} = 8.5 \cdot \text{kip} \cdot \text{ft}$	Maximum positive moment demand

GFRP reinforcement ratio is:

$$\rho_{f2.slab} := \frac{A_{f2.slab}}{b_{slab} \cdot d_{f2.slab}} = 0.01443$$

The balanced reinforcement ratio,  $\rho_{fb}$  is

[AASHTO GFRP 2009, 2.7.4.2-2]

$$\rho_{fb2.slab} := 0.85\beta_{1.super} \cdot \frac{f_{c.super}}{f_{fd.pr.slab}} \cdot \frac{E_{f.No6} \cdot \epsilon_{cu}}{E_{f.No6} \cdot \epsilon_{cu} + f_{fd.pr.slab}} = 0.012$$

The maximum tensile stress in the GFRP is:

[AASHTO GFRP 2009, 2.9.3.1-1]

$$f_{f2.slab} := \begin{cases} \sqrt{\frac{(E_{f.No6} \cdot \epsilon_{cu})^2}{4} + \frac{0.85\beta_{1.super} \cdot f_{c.super}}{\rho_{f2.slab}} E_{f.No6} \cdot \epsilon_{cu}} - 0.5 E_{f.No6} \cdot \epsilon_{cu} & \text{if } \rho_{f2.slab} \geq \rho_{fb2.slab} \\ f_{fd.pr.slab} & \text{otherwise} \end{cases}$$

$$f_{f2.slab} = 62.9 \cdot \text{ksi}$$

$f_{fs}$  cannot exceed  $f_{fu}$ , therefore, the following has to be checked:

$$\text{Recall design strength } f_{fd.pr.slab} = 70 \cdot \text{ksi}$$

$$\text{CheckMaxStress2} := \begin{cases} \text{"VERIFIED"} & \text{if } f_{t2.\text{slab}} \leq f_{t.d.pr.\text{slab}} \\ \text{"REDUCE BAR SPACING OR INCREASE BAR SIZE"} & \text{otherwise} \end{cases}$$

CheckMaxStress2 = "VERIFIED"

The stress-block depth is computed as per Eq.2.9.3.2.2-2 or Eq.2.9.3.2.2-4 whether  $\rho_f > \rho_{fb}$  or  $\rho_f < \rho_{fb}$ , respectively.

$$a_{f2.\text{slab}} := \frac{A_{f2.\text{slab}} \cdot f_{t2.\text{slab}}}{0.85 \cdot f'_{c.\text{super}} \cdot b_{\text{slab}}} = 1.19 \text{ in} \quad [\text{AASHTO GFRP 2009, 2.9.3.2.2-2}]$$

Neutral axis depth  $c_b$  at balanced strain conditions:

$$c_{b2.\text{slab}} := \left( \frac{\epsilon_{cu}}{\epsilon_{cu} + \epsilon_{f.d.No.pr.\text{slab}}} \right) \cdot d_{f2.\text{slab}} = 1.4 \text{ in} \quad [\text{AASHTO GFRP 2009, 2.9.3.2.2-4}]$$

The nominal moment capacity is: [AASHTO GFRP 2009, 2.9.3.2.2-1, 2.9.3.2.2-3]

$$M_{n\text{AASHTO\_2.slab}} := \begin{cases} A_{f2.\text{slab}} \cdot f_{t2.\text{slab}} \cdot \left( d_{f2.\text{slab}} - \frac{a_{f2.\text{slab}}}{2} \right) & \text{if } \rho_{f2.\text{slab}} \geq \rho_{fb2.\text{slab}} \\ A_{f2.\text{slab}} \cdot f_{t2.\text{slab}} \cdot \left( d_{f2.\text{slab}} - \frac{\beta_{1.\text{super}} \cdot c_{b2.\text{slab}}}{2} \right) & \text{otherwise} \end{cases}$$

$$M_{n\text{AASHTO\_2.slab}} = 30.7 \cdot \text{kip} \cdot \text{ft}$$



The strength reduction factor is computed as follows:

[AASHTO GFRP 2009, 2.7.4.2-1]

$$\phi_{f\_bar2.\text{slab}} := \begin{cases} 0.55 & \text{if } \rho_{f2.\text{slab}} \leq \rho_{fb2.\text{slab}} \\ 0.30 + 0.25 \cdot \frac{\rho_{f2.\text{slab}}}{\rho_{fb2.\text{slab}}} & \text{if } \rho_{fb2.\text{slab}} < \rho_{f2.\text{slab}} < 1.4 \cdot \rho_{fb2.\text{slab}} \\ 0.65 & \text{otherwise} \end{cases}$$

$$\phi_{f\_bar2.\text{slab}} = 0.6$$

The design flexural strength, equation, is computed as:

$$\phi_{f\_bar2.\text{slab}} \cdot M_{n\text{AASHTO\_2.slab}} = 19 \cdot \text{kip} \cdot \text{ft}$$

Recall  $M_{r.\text{pos}} = 9 \cdot \text{kip} \cdot \text{ft}$

$$\text{Check\_SlabFlexureAASHTO\_2} := \begin{cases} \text{"VERIFIED"} & \text{if } \phi_{f\_bar2.\text{slab}} \cdot M_{n\text{AASHTO\_2.slab}} \geq M_{r.\text{pos}} \\ \text{"NOT VERIFIED"} & \text{otherwise} \end{cases}$$

Check\_SlabFlexureAASHTO\_2 = "VERIFIED"



## B6. Development length at middle span



According to [AASHTO GFRP 2009 2.12.1.2], reinforcement should extend not less than the development length,  $L_{d, \text{pos}}$  beyond the point at which it is no longer required to resist flexure. and no more than 50% should be terminated at any section.

$$L_{d, \text{pos}} := \max \left( t_{\text{slab}}, 15 \cdot \text{diam}_{\text{No}_{\text{pr.slab}}}, \frac{L_{\text{span}}}{20} \right) = 22.3 \cdot \text{in} \quad [\text{AASHTO GFRP 2009, 2.12.1.2.1}]$$

Therefore, the selected development length  $L_{d, \text{pos.sl}}$  is chosen to be 2 ft, which is larger than the required  $L_{d, \text{pos}}$

$$L_{d, \text{pos.sl}} := 2 \text{ ft}$$



## B7. Reinforcement Splices



The tension lap splice length ( $L_{\text{sp}}$ ) should satisfy AASHTO GFRP 2009 2.12.2.1 and 2.12.4

Development length for deformed bars in tension is defined as  $L_{d, \text{tension}}$

Bar location modification factor  $\alpha$ , takes the value of 1 except for bars with more than 12 in of concrete cast below for which a value of 1.5 shall be adopted.

$$\alpha_{\text{slab}} := 1 \quad \text{Same value for positive and negative reinforcement being the slab 8 in. thick}$$

The calculation for lap splices for negative moment and positive moment

[AASHTO GFRP 2009, 2.10.3.1-1]

$$L_{d, \text{tension.neg.slab}} := \text{diam}_{\text{No}_{\text{pr.slab}}} \cdot \frac{\left( 31.6 \cdot \alpha_{\text{slab}} \cdot \frac{f_{f1, \text{slab}}}{\sqrt{f_{c, \text{super}} \cdot \text{ksi}}} \right) - 340}{13.6 + \frac{c_c}{d_{f1, \text{slab}}}} = 27.5 \cdot \text{in}$$

$$L_{d, \text{tension.pos.slab}} := \text{diam}_{\text{No}_{\text{pr.slab}}} \cdot \frac{\left( 31.6 \cdot \alpha_{\text{slab}} \cdot \frac{f_{f1, \text{slab}}}{\sqrt{f_{c, \text{super}} \cdot \text{ksi}}} \right) - 340}{13.6 + \frac{c_c}{d_{f1, \text{slab}}}} = 27.5 \cdot \text{in}$$

Reduction of splice length for excess of reinforcement [ACI318-14 25.4.10]. It is suggested to adopt a limit of 0.6:

$$\text{area}_{\text{required}} := \frac{M_{r, \text{pos}}}{f_{fd, \text{pr.slab}} \left( d_{f1, \text{slab}} - \frac{\beta_{1, \text{super}} \cdot c_{b1, \text{slab}}}{2} \right)} = 0.3 \cdot \text{in}^2 \quad [\text{AASHTO GFRP 2009, 2.9.3.2.2-3}]$$

Area per linear foot required at midspan and support, considering the section under-reinforced ( $\rho_f < \rho_{fb}$ )

$\text{area}_{\text{provided}} := A_{\text{fl.slabs}} = 1.1 \cdot \text{in}^2$       area per linear foot provided at midspan and support (symmetric)

$$\text{over\_reinf\_ratio} := \begin{cases} \frac{\text{area}_{\text{required}}}{\text{area}_{\text{provided}}} & \text{if } \frac{\text{area}_{\text{required}}}{\text{area}_{\text{provided}}} \geq 0.6 \\ 0.6 & \text{otherwise} \end{cases}$$

$\text{over\_reinf\_ratio} = 0.6$

$L_{\text{tension.reduced}} := L_{\text{d.tension.neg.slabs}} \cdot \text{over\_reinf\_ratio} = 1.4 \text{ ft}$       [ACI318-14 25.4.10]

Lap splice length  $L_{\text{sp,sl}}$  :

$L_{\text{sp.neg}} := \max(12 \text{ in}, 1.3 \cdot L_{\text{tension.reduced}}) = 21 \cdot \text{in}$       [AASHTO GFRP 2009, 2.12.4 ]

$L_{\text{sp.pos}} := \max(12 \text{ in}, 1.3 \cdot L_{\text{tension.reduced}}) = 21 \cdot \text{in}$       [AASHTO GFRP 2009, 2.12.4 ]



## C. Shear Verification



The nominal shear resistance provide by concrete,  $V_c$

$$b_{\text{slab}} = 12 \cdot \text{in} \quad \text{unitary width}$$

$$c_{1.\text{slab}} := \frac{a_{f1.\text{slab}}}{\beta_{1.\text{super}}} = 1.5 \cdot \text{in} \quad \text{neutral axis depth at support}$$

$$c_{2.\text{slab}} := \frac{a_{f1.\text{slab}}}{\beta_{1.\text{super}}} = 1.5 \cdot \text{in} \quad \text{neutral axis depth at middle span}$$

$$V_{c1.\text{slab}} := 0.16 \sqrt{f'_{c.\text{super}} \cdot \text{ksi}} \cdot b_{\text{slab}} \cdot c_{1.\text{slab}} = 6.9 \cdot \text{kip} \quad [\text{AASHTO GFRP 2009, 2.7.4.2}]$$

Resistance factor  $\phi_v$  for shear is 0.75 [AASHTO GFRP 2009, 2.7.4.2]

$$\phi_v \cdot V_{c1.\text{slab}} = 5.2 \cdot \text{kip}$$

Compute ultimate shear and ensure compliance



## D. Crack Width Verification

### D1. Data recall (section B of chapter 1.04)



Crack width is checked using Equation 2.9.3.4-1 of AASHTO GFRP 2009. A crack width limit,  $w_{lim}$  of 0.020 in. is used.

$$w_{lim} := 0.020 \text{in} \quad \text{Crack width limit}$$

$$\text{diam}_{\text{No.pr.slab}} = 0.75 \cdot \text{in} \quad \text{Diameter of deck primary GFRP reinforcement}$$

$$\text{area}_{\text{No.pr.slab}} = 0.44 \cdot \text{in}^2 \quad \text{Area of deck primary GFRP reinforcement}$$

$$E_{f,\text{No6}} = 7000 \cdot \text{ksi} \quad \text{Modulus of elasticity of deck primary GFRP reinforcement}$$

$$f_{fu,\text{No6}} = 100 \cdot \text{ksi} \quad \text{Tensile strength of deck primary reinforcement for product certification as reported by GFRP manufacturer [AASHTO GFRP 2009, 2.6.1.2]}$$

$$f_{fd,\text{pr.slab}} = 70 \cdot \text{ksi} \quad \text{Design strength of deck primary reinforcement considering reduction for service environment [AASHTO GFRP 2009, 2.6.1.2-1]}$$

$$\epsilon_{fu,\text{No.pr.slab}} = 1.4\% \quad \text{Tensile strain of deck primary reinforcement for product certification as reported by GFRP manufacturer [AASHTO GFRP 2009, 2.6.1.2]}$$

$$\epsilon_{fd,\text{No.pr.slab}} = 1\% \quad \text{Design strain of deck primary reinforcement reinforcement considering reduction for service environment [AASHTO GFRP 2009, 2.6.1.2]}$$





## D2. Support



Recall crack width limit  $w_{lim} = 0.02 \cdot \text{in}$

Ratio of modulus of elasticity of bars to modulus of elasticity of concrete  $n_{f,slab} := \frac{E_{fNo_{pr,slab}}}{E_{c.super}} = 1.7$

Ratio of depth of neutral axis to reinforcement depth

$$k_{1,slab} := \sqrt{2\rho_{fl,slab} \cdot n_{f,slab} + (\rho_{fl,slab} \cdot n_{f,slab})^2} - \rho_{fl,slab} \cdot n_{f,slab}$$

$$k_{1,slab} = 0.2$$

Tensile stress in GFRP under service loads  $f_{fs1,slab} := \frac{M_{neg}}{A_{f1,slab} \cdot d_{f1,slab} \cdot \left(1 - \frac{k_{1,slab}}{3}\right)} = 5.7 \cdot \text{ksi}$

Ratio of distance from neutral axis to extreme tension fiber to distance from neutral axis to center of tensile reinforcement

$$\beta_{11,slab} := \frac{t_{slab} - k_{1,slab} \cdot d_{f1,slab}}{d_{f1,slab} \cdot (1 - k_{1,slab})} = 1.4$$

Thickness of concrete cover measured from extreme tension fiber to center of bar

$$d_{c1,slab} := t_{slab} - d_{f1,slab} = 1.9 \cdot \text{in}$$

Bond factor (provided by the manufacturer)

$$k_b := 0.9$$

The crack width under service loads is: [AASHTO GFRP 2009, 2.9.3.4-1]

$$w_{1,slab} := 2 \frac{f_{fs1,slab}}{E_{fNo_{pr,slab}}} \beta_{11,slab} \cdot k_b \cdot \sqrt{d_{c1,slab}^2 + \left(\frac{s_{f\_bar1,slab}}{2}\right)^2} = 0.007 \cdot \text{in}$$

The crack width limit is:

$$w_{lim} = 0.02 \cdot \text{in}$$

Check\_SlabCrack1 :=  $\begin{cases} \text{"VERIFIED"} & \text{if } w_{1,slab} \leq w_{lim} \\ \text{"NOT VERIFIED"} & \text{otherwise} \end{cases}$

Check\_SlabCrack1 = "VERIFIED"

The maximum recommended bar spacing to limit cracking is:

$$s_{\text{Ospina}_1.\text{slab}} := \min \left( 1.15 \cdot \frac{E_{f\text{No.pr.slab}} \cdot w_{\text{lim}}}{f_{fs1.\text{slab}} \cdot k_b} - 2.5 \cdot c_c, 0.92 \cdot \frac{E_{f\text{No.pr.slab}} \cdot w_{\text{lim}}}{f_{fs1.\text{slab}} \cdot k_b} \right) = 23.5 \cdot \text{in}$$

$$\text{Check\_SpacingOspina1} := \begin{cases} \text{"VERIFIED"} & \text{if } s_{f\_bar1.\text{slab}} \leq s_{\text{Ospina}_1.\text{slab}} \\ \text{"NOT VERIFIED"} & \text{otherwise} \end{cases}$$

Check\_SpacingOspina1 = "VERIFIED"



### D3. Middle Span



Recall crack width limit

$$w_{\text{lim}} = 0.02 \cdot \text{in}$$

Ratio of modulus of elasticity of bars to modulus of elasticity of concrete

$$n_{f.\text{slab}} = 1.7$$

Ratio of depth of neutral axis to reinforcement depth

$$k_{2.\text{slab}} := k_{1.\text{slab}} = 0.2$$

Bar spacing

$$s_{f\_bar2.\text{slab}} := s_{f\_bar1.\text{slab}} = 5 \cdot \text{in}$$

Tensile stress in GFRP under service loads

$$f_{fs2.\text{slab}} := \frac{M_{\text{pos}}}{A_{f2.\text{slab}} \cdot d_{f2.\text{slab}} \cdot \left( 1 - \frac{k_{2.\text{slab}}}{3} \right)} = 9.8 \cdot \text{ksi}$$

Ratio of distance from neutral axis to extreme tension fiber to distance from neutral axis to center of tensile reinforcement

$$\beta_{12.\text{slab}} := \frac{t_{\text{slab}} - k_{2.\text{slab}} \cdot d_{f2.\text{slab}}}{d_{f2.\text{slab}} \cdot (1 - k_{2.\text{slab}})} = 1.4$$

Thickness of concrete cover measured from extreme tension fiber to center of bar

$$d_{c2.\text{slab}} := t_{\text{slab}} - d_{f2.\text{slab}} = 1.9 \cdot \text{in}$$

Bond factor (provided by the manufacturer)

$$k_b = 0.9$$

The crack width under service loads is:

[AASHTO GFRP 2009, 2.9.3.4-1]

$$w_{2.slab} := 2 \frac{f_{fs2.slab}}{E_{fNo_{pr.slab}}} \beta_{11.slab} \cdot k_b \cdot \sqrt{d_{c1.slab}^2 + \left( \frac{s_{f\_bar1.slab}}{2} \right)^2} = 0.012 \cdot \text{in}$$

The crack width limit is:

$$w_{lim} = 0.02 \cdot \text{in}$$

$$\text{Check\_SlabCrack2} := \begin{cases} \text{"VERIFIED"} & \text{if } w_{2.slab} \leq w_{lim} \\ \text{"NOT VERIFIED"} & \text{otherwise} \end{cases}$$

Check\_SlabCrack2 = "VERIFIED"

The maximum recommended bar spacing to limit cracking is:

$$s_{Ospina\_2.slab} := \min \left( 1.15 \cdot \frac{E_{fNo_{pr.slab}} \cdot w_{lim}}{f_{fs2.slab} \cdot k_b} - 2.5 \cdot c_c, 0.92 \cdot \frac{E_{fNo_{pr.slab}} \cdot w_{lim}}{f_{fs2.slab} \cdot k_b} \right) = 13.2 \cdot \text{in}$$

$$\text{Check\_SlabSpacingOspina2} := \begin{cases} \text{"VERIFIED"} & \text{if } s_{f\_bar2.slab} \leq s_{Ospina\_2.slab} \\ \text{"NOT VERIFIED"} & \text{otherwise} \end{cases}$$

Check\_SlabSpacingOspina2 = "VERIFIED"



## E. Secondary Reinforcement

### E1.Data recall (section B of Chapter 1.04)



$No_{sec.slab} = 6$	Deck secondary GFRP reinforcement
$diam_{No_{sec.slab}} = 0.75 \cdot \text{in}$	Diameter of deck secondary GFRP reinforcement
$area_{No_{sec.slab}} = 0.44 \cdot \text{in}^2$	Area of deck secondary GFRP reinforcement
$E_{f.No6} = 7000 \cdot \text{ksi}$	Modulus of elasticity of deck primary GFRP reinforcement
$f_{fu.No6} = 100 \cdot \text{ksi}$	Tensile strength of deck primary reinforcement for product certification as reported by GFRP manufacturer
$f_{fd.sec.slab} = 63 \cdot \text{ksi}$	Design strength of deck secondary reinforcement considering reduction for service environment [AASHTO GFRP 2009, 2.6.1.2-1]
$\epsilon_{fu.No_{sec.slab}} = 1.4 \cdot \%$	Tensile strain of deck secondary reinforcement for product certification as reported by GFRP manufacturers [AASHTO GFRP 2009, 2.6.1.2]
$\epsilon_{fd.No.sec.slab} = 1 \cdot \%$	Design strain of deck secondary reinforcement reinforcement considering reduction for service environment [AASHTO GFRP 2009, 2.6.1.2]



## E2.Distribution reinforcement



Reinforcement shall be placed in the secondary direction at the bottom of the slab as a percentage of the primary reinforcement for positive moment as follows:

For primary reinforcement perpendicular to traffic: [AASHTO GFRP 2009, 2.11.4.2]

$$\text{Recall } A_{f2.sl\text{ab}} = 1.1 \cdot \text{in}^2$$

The required secondary reinforcement parallel to traffic  $A_{\text{sec.req}}$  [AASHTO GFRP 2009, 2.11.4.2]

$$A_{\text{sec.req.sl\text{ab}}} := \min\left(67\%, \frac{200\%}{\sqrt{\frac{S_b - 2\text{ft}}{\text{ft}}}}\right) \cdot A_{f2.sl\text{ab}} = 0.7 \cdot \text{in}^2$$

$S_b - 2\text{ft}$  Effective span between beams

The design width in transverse direction is:

$$b_{\text{trans}} := 12\text{in}$$

The required number of #5 for secondary reinforcement  $N_{\text{sec.req}}$

$$\text{Recall } \text{diam}_{\text{No}_{\text{sec.sl\text{ab}}}} = 0.8 \cdot \text{in} \quad \text{area}_{\text{No}_{\text{sec.sl\text{ab}}}} = 0.4 \cdot \text{in}^2$$

$$N_{\text{sec.req.sl\text{ab}}} := \frac{A_{\text{sec.req.sl\text{ab}}}}{\text{area}_{\text{No}_{\text{sec.sl\text{ab}}}}} = 1.6$$

The required spacing of #6 reinforcement  $S_{\text{sec.req}}$

$$S_{\text{sec.req.sl\text{ab}}} := \frac{b_{\text{trans}}}{N_{\text{sec.req.sl\text{ab}}}} = 7.5 \cdot \text{in}$$

The design number of #6 for secondary reinforcement  $N_{\text{sec.des}}$  is selected to be:

$$N_{\text{sec.des.sl\text{ab}}} := 2 \quad \text{No.6 at 6 in. spacing at the bottom}$$

$$S_{\text{sec.des.sl\text{ab}}} := \frac{b_{\text{trans}}}{N_{\text{sec.des.sl\text{ab}}}} = 6 \cdot \text{in}$$

Spacing for minimum spacing

$$S_{\text{sec.min.sl\text{ab}}} := \max\left(1.5 \text{diam}_{\text{No}_{\text{sec.sl\text{ab}}}}, 1.5\text{in}\right) = 1.5 \cdot \text{in}$$

$$\text{The bar clear spacing is: } S_{\text{sec.des.sl\text{ab}}} - \text{diam}_{\text{No}_{\text{sec.sl\text{ab}}}} = 5.3 \cdot \text{in}$$

$$\text{CheckingSecondarySpacing} := \begin{cases} \text{"VERIFIED"} & \text{if } S_{\text{sec.des.sl\text{ab}}} - \text{diam}_{\text{No}_{\text{sec.sl\text{ab}}}} \geq S_{\text{sec.min.sl\text{ab}}} \\ \text{"NOT VERIFIED"} & \text{otherwise} \end{cases}$$

$$\text{CheckingSecondarySpacing} = \text{"VERIFIED"}$$



## F. Shrinkage and Temperature Reinforcement

### F1.Data recall (section B of chapter 1.04)



$N_{o_{sec.slab}} = 6$	Deck secondary GFRP reinforcement
$diam_{N_{o_{sec.slab}}} = 0.75 \cdot \text{in}$	Diameter of deck secondary GFRP reinforcement
$area_{N_{o_{sec.slab}}} = 0.44 \cdot \text{in}^2$	Area of deck secondary GFRP reinforcement
$E_{f.No6} = 7000 \cdot \text{ksi}$	Modulus of elasticity of deck primary GFRP reinforcement
$f_{fu.No6} = 100 \cdot \text{ksi}$	Tensile strength of deck primary reinforcement for product certification as reported by GFRP manufacturer [AASHTO GFRP 2009, 2.6.1.2]
$f_{fd.sec.slab} = 63 \cdot \text{ksi}$	Design strength of deck secondary reinforcement considering reduction for service environment [AASHTO GFRP 2009, 2.6.1.2-1]
$\epsilon_{fuNo_{sec.slab}} = 1.4\%$	Tensile strain of deck secondary reinforcement for product certification as reported by GFRP manufacturers [AASHTO GFRP 2009, 2.6.1.2]
$\epsilon_{fdNo_{sec.slab}} = 1\%$	Design strain of deck secondary reinforcement reinforcement considering reduction for service environment [AASHTO GFRP 2009, 2.6.1.2]



### F2.Shrinkage and temperature reinforcement



The ratio of GFRP shrinkage and temperature reinforcement area to gross concrete area  $\rho_{f,st}$ :  
[AASHTO GFRP 2009, 2.11.5]

$$\rho_{f,st} := \min \left( \max \left( 0.0014, 0.0018 \cdot \frac{60 \text{ksi}}{f_{fd.sec.slab}} \cdot \frac{E_s}{E_{fNo_{sec.slab}}} \right), 0.0036 \right) = 0.0036$$

The design width in the transverse direction

$$b_{trans} = 12 \cdot \text{in}$$

$$A_{g,trans} := b_{trans} \cdot t_{slab} = 96 \cdot \text{in}^2$$

GFRP shrinkage and temperature reinforcement area  $A_{st}$

$$A_{st.slab} := \rho_{f,st} \cdot A_{g,trans} = 0.3 \cdot \text{in}^2$$

The number of required reinforcement for shrinkage and temperature  $N_{st,req}$

$$\text{Recall } diam_{N_{o_{sec.slab}}} = 0.8 \cdot \text{in} \quad area_{N_{o_{sec.slab}}} = 0.4 \cdot \text{in}^2$$

$$N_{st,req.slab} := \frac{A_{st.slab}}{area_{N_{o_{sec.slab}}}} = 0.8$$

Therefore, the number of bars for shrinkage and temperature  $N_{st,des}$  is chosen to be 2 placed at the bottom layer.

$$N_{st,des,slab} := 2$$

Therefore, spacing  $S_{st,slt}$ .

$$S_{st,prvd,slab} := \frac{b_{trans}}{N_{st,des,slab}} = 6 \cdot \text{in}$$

According to Bridge design guide specification for GFRP reinforcement, the max spacing for shrinkage and temperature  $S_{st,max}$

$$S_{st,max,slab} := \min(3 \cdot t_{slab}, 12 \text{in}) = 12 \cdot \text{in} \quad [\text{AASHTO GFRP 2009, 2.11.5}]$$

$$\text{Check\_ST\_Spacing} := \begin{cases} \text{"VERIFIED"} & \text{if } S_{st,prvd,slab} \leq S_{st,max,slab} \\ \text{"NOT VERIFIED"} & \text{otherwise} \end{cases} \quad [\text{AASHTO GFRP 2009, 2.11.5}]$$

$$\text{Check\_ST\_Spacing} = \text{"VERIFIED"}$$



## G. Deflection Verification

### Preliminary Calculations



The maximum allowable deflection due to live load including dynamic effect is:

$$\Delta_{lim,slab} := \frac{S_b}{800} = 0.079 \cdot \text{in} \quad [\text{AASHTO GFRP 2009, 2.7.2}]$$

The gross moment of inertia is:

$$I_{g,slab} := \frac{b_{slab} \cdot t_{slab}^3}{12} = 512 \cdot \text{in}^4$$

The negative cracking moment is:

$$M_{crNeg,slab} := \frac{f_{r,super} \cdot I_{g,slab}}{t_{slab} - c_{1,slab} - c_c} = 4.78 \cdot \text{kip} \cdot \text{ft}$$

The positive cracking moment is:

$$M_{crPos,slab} := \frac{f_{r,super} \cdot I_{g,slab}}{t_{slab} - c_{2,slab} - c_c} = 4.78 \cdot \text{kip} \cdot \text{ft}$$



### Cracked Moment of Inertia



The cracked moment of inertia,  $I_{cr}$ , is computed as follows:

[AASHTO GFRP 2009, Equation 2.7.3-3]

- Case 1: Mid-span

$$I_{cr2.slab} := \frac{b_{slab} \cdot d_{f2.slab}^3}{3} k_{2.slab}^3 + n_{f.slab} \cdot A_{f2.slab} \cdot d_{f2.slab}^2 \cdot (1 - k_{2.slab})^2 = 50 \cdot \text{in}^4$$

- Case 2: Internal support

$$I_{cr1.slab} := \frac{b_{slab} \cdot d_{f1.slab}^3}{3} k_{1.slab}^3 + n_{f.slab} \cdot A_{f1.slab} \cdot d_{f1.slab}^2 \cdot (1 - k_{1.slab})^2 = 50 \cdot \text{in}^4$$



### Effective Moment of Inertia



The effective moment of inertia,  $I_e$ , is computed using AASHTO LRFD 2014 Eq.5.7.3.6.2-1.

The maximum positive bending moment for exterior span due to service loads is:

$$M_{pos} = 5 \cdot \text{kip} \cdot \text{ft}$$

The value of  $I_e$  at midspan is:

$$\text{Recall } I_{g.slab} = 512 \cdot \text{in}^4$$

The effective moment of inertia,  $I_{e2.slab}$  at where the maximum positive moment due to service load is: [AASHTO LRFD 2014, 5.7.3.6.2-1]

$$I_{e2.slab} := \min \left[ I_{g.slab}, \left( \frac{M_{crPos.slab}}{M_{pos}} \right)^3 \cdot I_{g.slab} + \left[ 1 - \left( \frac{M_{crPos.slab}}{M_{pos}} \right)^3 \right] I_{cr2.slab} \right] = 462 \cdot \text{in}^4$$



### Maximum Deflection



The maximum allowable deflection is:

$$\Delta_{lim.slab} = 0.0788 \cdot \text{in}$$

The thickness of slab satisfies the minimum requirement of AASHTO LRFD 2014 Bridge Design Specification Table 2.5.2.6.3-1. The instantaneous deflection to be used for the calculation of the long-time deflection is based on the magnification factor.

Considering the bridge is continuous and simply supported, the exterior span can be assumed to be at pinned at one end and fixed at other. Therefore, according to deflection formula of uniformly loaded fixed-pinned beam.

Maximum positive moment due to live load for the exterior span:

$$M_{sPos} = 4.7 \cdot \text{kip} \cdot \text{ft}$$

The maximum instantaneous deflection under live loads is:

$$\Delta_{SL.slab.ins} := \frac{8}{185} \cdot \frac{M_{sPos} \cdot S_b^2}{E_{c.super} \cdot I_{e2.slab}} = 0.0054 \cdot \text{in}$$

The magnification factor for long-term deflection under live loads is taken directly from AASHTO LRFD 2014 Section 5.7.6.3.2-Here the presence of compression reinforcement ( $A'_r=2/3A_{fl.slab}$ ) is considered even if such reinforcement is not taken into account for strength calculation.

[AASHTO LRFD 2014, 5.7.3.6.3.2]

$$\text{factor}_{lt} := \begin{cases} \max\left(1.6, 3 - 1.2 \cdot \frac{\frac{2}{3} \cdot A_{f1.slab}}{A_{f2.slab}}\right) & \text{if } I_{e2.slab} < I_{g.slab} \\ 4 & \text{if } I_{e2.slab} = I_{g.slab} \end{cases} = 2.2$$

$$\Delta_{SL.slab.lt} := \text{factor}_{lt} \cdot \Delta_{SL.slab.ins} = 0.012 \cdot \text{in}$$

$$\text{Check\_SlabInstantaneousDeflection} := \begin{cases} \text{"VERIFIED"} & \text{if } \Delta_{SL.slab.ins} \leq \Delta_{lim.slab} \\ \text{"SERVICEABILITY SUGGESTION IS NOT MET"} & \text{otherwise} \end{cases}$$

Check\_SlabInstantaneousDeflection = "VERIFIED"

$$\text{Check\_SlabLongTermDeflection} := \begin{cases} \text{"VERIFIED"} & \text{if } \Delta_{SL.slab.lt} \leq \Delta_{lim.slab} \\ \text{"SERVICEABILITY SUGGESTION IS NOT MET"} & \text{otherwise} \end{cases}$$

Check\_SlabLongTermDeflection = "VERIFIED"

Even though the instantaneous and long-time deflections are higher than the maximum allowable deflection, the design is considered satisfactory as the effect of parapets and edge beam are disregarded. More sophisticated tools could be considered for the computation of deflections.





**H. Overhang Reinforcement [SDG 4.2.4.B]**

$A_{s,top} := \frac{0.8in^2}{2} = 0.4 \cdot in^2$       minimum top overhang reinforcement per ft (TL-4 F shape barrier)

$A_{s,bottom} := \frac{0.8in^2}{2} = 0.4 \cdot in^2$       minimum bottom overhang reinforcement per ft (TL-4 F shape barrier)

GFRP := 2      GFRP multiplier adopted to establish an equivalency with current provisions that are only for steel

Required top overhang reinforcing area.....  $A_{ovrhng.reinf.top} := GFRP \cdot A_{s,top} = 0.8 \cdot in^2$  per ft (SDG 4.2.4.B)

Required bottom overhang reinforcing area.....  $A_{ovrhng.reinf.bottom} := GFRP \cdot A_{s,top} = 0.8 \cdot in^2$  per ft

Provided top & bottom transverse reinforcing area.....  $A_{s,neg} := (A_{fl.slab}) = 1.1 \cdot in^2$

Check provided top reinforcing area in overhang .....  $Check_{ovrhng.reinf.top} := if(A_{s,neg} < A_{ovrhng.reinf.top}, "NG", "OK")$

Check provided bottom reinforcing area in overhang .....  $Check_{ovrhng.reinf.bottom} := if(A_{s,neg} < A_{ovrhng.reinf.bottom}, "NG", "OK")$

$Check_{ovrhng.reinf.top} = "OK"$

$Check_{ovrhng.reinf.bottom} = "OK"$

*note: If check is " OK ," top transverse reinforcing area provided meets SDG 4.2.4.B requirement.  
If check is " NG" , provide additional reinforcing to meet SDG 4.2.4.B requirement.*

Since the reinforcing area provided is more than the reinforcing area required in the overhang, no additional reinforcement must be added to meet SDG 4.2.4.B requirements.

## I. Summary of Reinforcement Provided and Detailing

### Primary reinforcement perpendicular to traffic



$No_{pr.slab} = 6$	Bar number of primary reinforcement (top and bottom)
$N_{f\_bar1.slab} = 2.4$	Number of bars per ft
$s_{f\_bar1.slab} = 5 \cdot in$	Spacing
$L_{d.neg.min} = 2.3 \text{ ft}$	Development length for negative moment region
$L_{d.pos.sl} = 2 \text{ ft}$	Development length for positive moment region
$L_{sp.neg} = 21 \cdot in$	Splice length for negative moment region
$L_{sp.pos} = 21 \cdot in$	Splice length for positive moment region



### Secondary reinforcement parallel to traffic



$No_{sec.slab} = 6$	Bar number of secondary (shrinkage) reinforcement (bottom only)
$S_{sec.des.slab} = 6 \cdot in$	Bar spacing in the top layer
$L_{d.neg.min} = 2.3 \text{ ft}$	Development length for negative moment region
$L_{d.pos.sl} = 2 \text{ ft}$	Development length for positive moment region
$L_{sp.neg} = 21 \cdot in$	Splice length for negative moment region
$L_{sp.pos} = 21 \cdot in$	Splice length for positive moment region

No secondary (shrinkage) reinforcement at the top layer



### Reinforcement layout



**APPENDIX C:**  
**UNIVERSITY OF MIAMI PEDESTRIAN BRIDGE:**  
**DRAWINGS AND DECK DESIGN CALCULATIONS**









PROJECT NO. 1000-1-100-100 CONTRACT NO. 1000-1-100-100				
SHEET NO. 1000-1-100-100				
DATE: 10/10/00				
DRAWN BY: J. J. J.				
CHECKED BY: J. J. J.				
APPROVED BY: J. J. J.				
BRIDGE PLANS AND DETAILS				
<b>S2.1</b>				

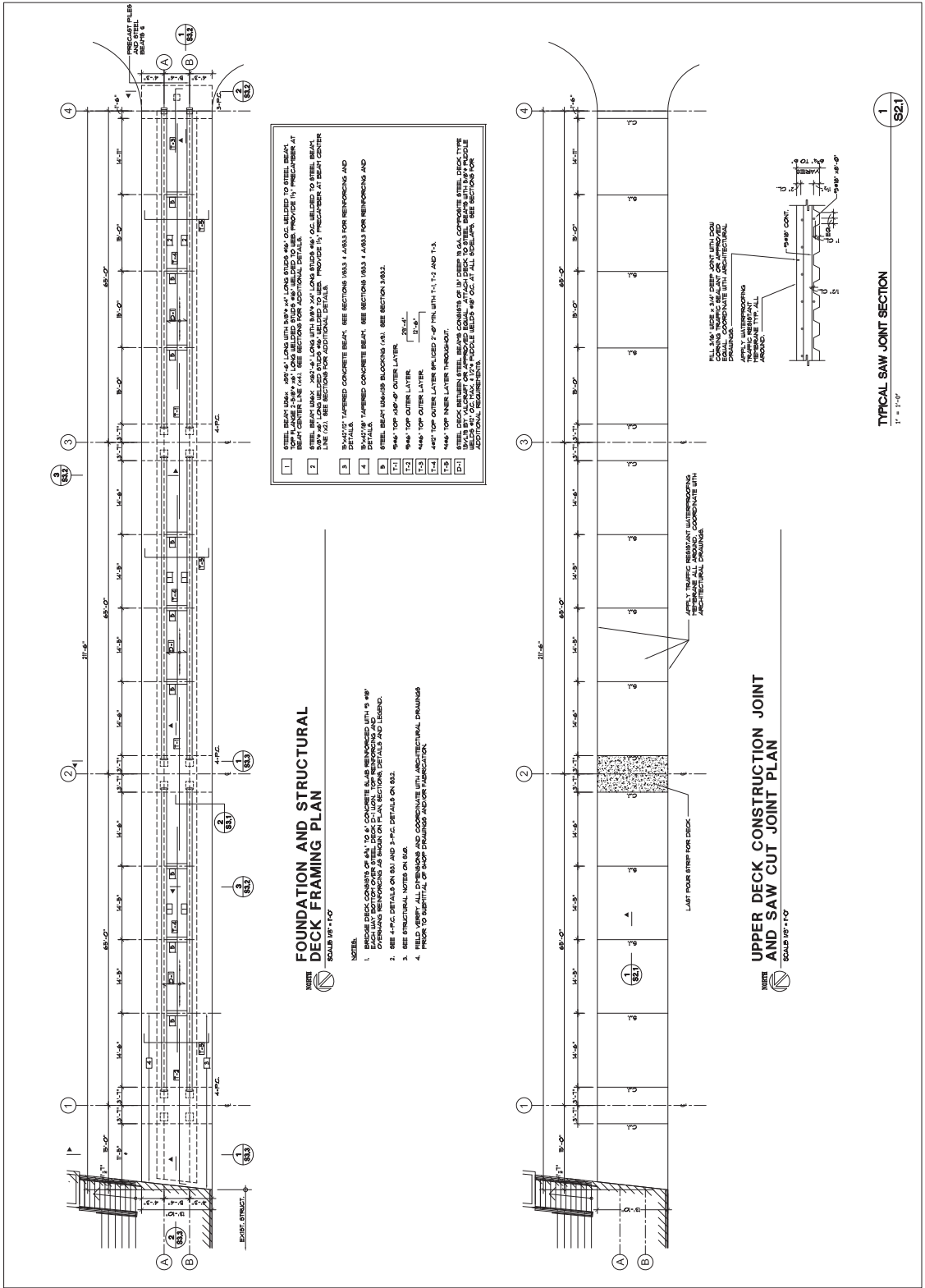



DATE: 11/15/10 DRAWN BY: J. J. HARRIS CHECKED BY: J. J. HARRIS DESIGNED BY: J. J. HARRIS PROJECT NO.: 100-1-110-100	SHEET NO.: 33.3 BRIDGE SECTIONS AND DETAILS SCALE: AS SHOWN
---	---

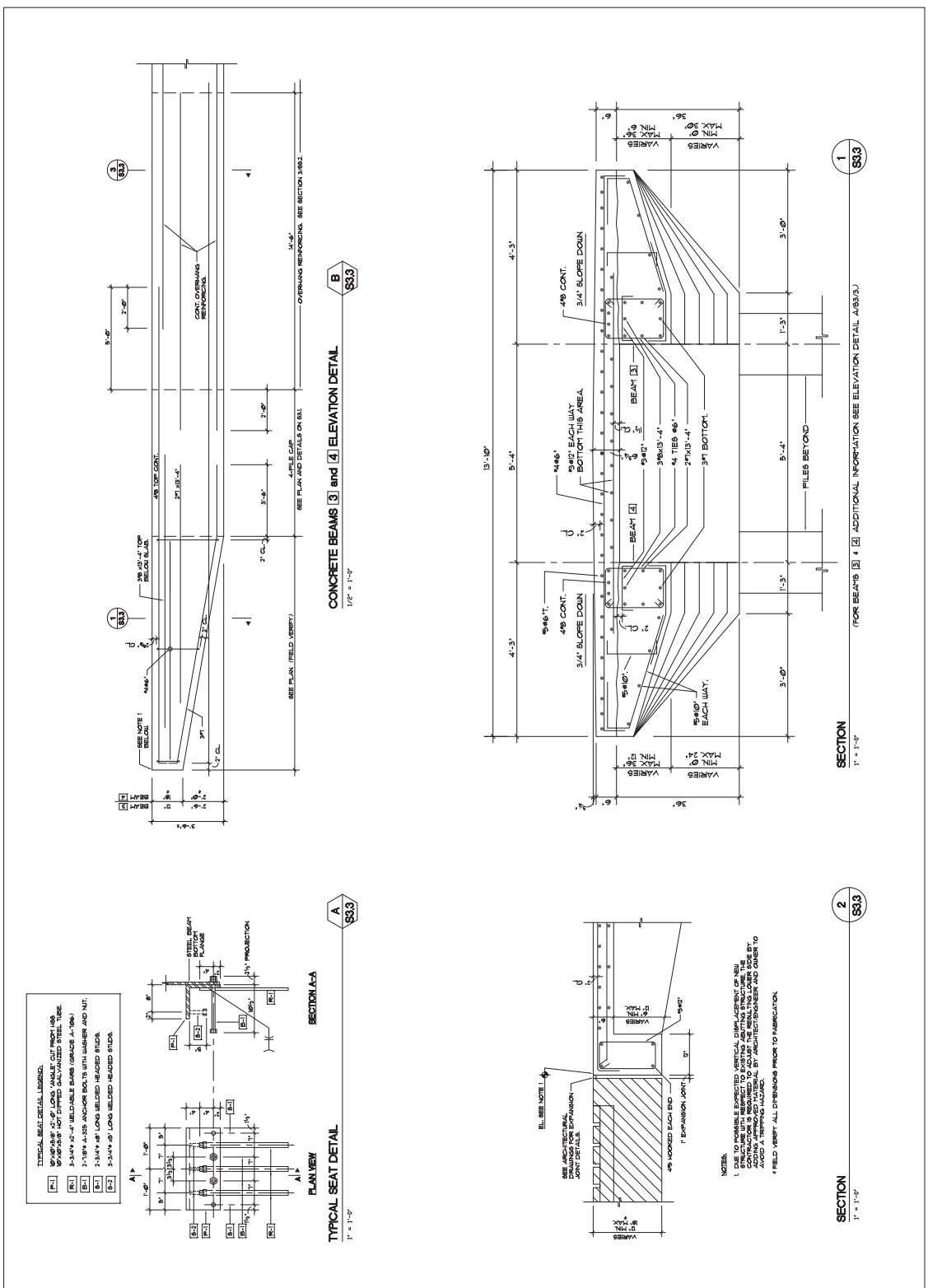

- TYPICAL BEAM DETAIL LEGEND:**
- (R1) 5/8" x 3/8" x 1/2" LONG ANGLE, CUT FRONT END
  - (R2) 5/8" x 3/8" x 1/2" LONG ANGLE, CUT FRONT END
  - (R3) 3/4" x 3/4" x 1/2" WELDABLE BEAMS (GRADE A-160)
  - (R4) 2" x 4" x 1/2" WELDABLE BEAMS (GRADE A-160)
  - (R5) 2" x 4" x 1/2" WELDABLE BEAMS (GRADE A-160)
  - (R6) 2" x 4" x 1/2" WELDABLE BEAMS (GRADE A-160)
  - (R7) 2" x 4" x 1/2" WELDABLE BEAMS (GRADE A-160)
  - (R8) 2" x 4" x 1/2" WELDABLE BEAMS (GRADE A-160)
  - (R9) 2" x 4" x 1/2" WELDABLE BEAMS (GRADE A-160)
  - (R10) 2" x 4" x 1/2" WELDABLE BEAMS (GRADE A-160)
  - (R11) 2" x 4" x 1/2" WELDABLE BEAMS (GRADE A-160)
  - (R12) 2" x 4" x 1/2" WELDABLE BEAMS (GRADE A-160)
  - (R13) 2" x 4" x 1/2" WELDABLE BEAMS (GRADE A-160)
  - (R14) 2" x 4" x 1/2" WELDABLE BEAMS (GRADE A-160)
  - (R15) 2" x 4" x 1/2" WELDABLE BEAMS (GRADE A-160)
  - (R16) 2" x 4" x 1/2" WELDABLE BEAMS (GRADE A-160)
  - (R17) 2" x 4" x 1/2" WELDABLE BEAMS (GRADE A-160)
  - (R18) 2" x 4" x 1/2" WELDABLE BEAMS (GRADE A-160)
  - (R19) 2" x 4" x 1/2" WELDABLE BEAMS (GRADE A-160)
  - (R20) 2" x 4" x 1/2" WELDABLE BEAMS (GRADE A-160)
  - (R21) 2" x 4" x 1/2" WELDABLE BEAMS (GRADE A-160)
  - (R22) 2" x 4" x 1/2" WELDABLE BEAMS (GRADE A-160)
  - (R23) 2" x 4" x 1/2" WELDABLE BEAMS (GRADE A-160)
  - (R24) 2" x 4" x 1/2" WELDABLE BEAMS (GRADE A-160)
  - (R25) 2" x 4" x 1/2" WELDABLE BEAMS (GRADE A-160)
  - (R26) 2" x 4" x 1/2" WELDABLE BEAMS (GRADE A-160)
  - (R27) 2" x 4" x 1/2" WELDABLE BEAMS (GRADE A-160)
  - (R28) 2" x 4" x 1/2" WELDABLE BEAMS (GRADE A-160)
  - (R29) 2" x 4" x 1/2" WELDABLE BEAMS (GRADE A-160)
  - (R30) 2" x 4" x 1/2" WELDABLE BEAMS (GRADE A-160)
  - (R31) 2" x 4" x 1/2" WELDABLE BEAMS (GRADE A-160)
  - (R32) 2" x 4" x 1/2" WELDABLE BEAMS (GRADE A-160)
  - (R33) 2" x 4" x 1/2" WELDABLE BEAMS (GRADE A-160)
  - (R34) 2" x 4" x 1/2" WELDABLE BEAMS (GRADE A-160)
  - (R35) 2" x 4" x 1/2" WELDABLE BEAMS (GRADE A-160)
  - (R36) 2" x 4" x 1/2" WELDABLE BEAMS (GRADE A-160)
  - (R37) 2" x 4" x 1/2" WELDABLE BEAMS (GRADE A-160)
  - (R38) 2" x 4" x 1/2" WELDABLE BEAMS (GRADE A-160)
  - (R39) 2" x 4" x 1/2" WELDABLE BEAMS (GRADE A-160)
  - (R40) 2" x 4" x 1/2" WELDABLE BEAMS (GRADE A-160)
  - (R41) 2" x 4" x 1/2" WELDABLE BEAMS (GRADE A-160)
  - (R42) 2" x 4" x 1/2" WELDABLE BEAMS (GRADE A-160)
  - (R43) 2" x 4" x 1/2" WELDABLE BEAMS (GRADE A-160)
  - (R44) 2" x 4" x 1/2" WELDABLE BEAMS (GRADE A-160)
  - (R45) 2" x 4" x 1/2" WELDABLE BEAMS (GRADE A-160)
  - (R46) 2" x 4" x 1/2" WELDABLE BEAMS (GRADE A-160)
  - (R47) 2" x 4" x 1/2" WELDABLE BEAMS (GRADE A-160)
  - (R48) 2" x 4" x 1/2" WELDABLE BEAMS (GRADE A-160)
  - (R49) 2" x 4" x 1/2" WELDABLE BEAMS (GRADE A-160)
  - (R50) 2" x 4" x 1/2" WELDABLE BEAMS (GRADE A-160)
  - (R51) 2" x 4" x 1/2" WELDABLE BEAMS (GRADE A-160)
  - (R52) 2" x 4" x 1/2" WELDABLE BEAMS (GRADE A-160)
  - (R53) 2" x 4" x 1/2" WELDABLE BEAMS (GRADE A-160)
  - (R54) 2" x 4" x 1/2" WELDABLE BEAMS (GRADE A-160)
  - (R55) 2" x 4" x 1/2" WELDABLE BEAMS (GRADE A-160)
  - (R56) 2" x 4" x 1/2" WELDABLE BEAMS (GRADE A-160)
  - (R57) 2" x 4" x 1/2" WELDABLE BEAMS (GRADE A-160)
  - (R58) 2" x 4" x 1/2" WELDABLE BEAMS (GRADE A-160)
  - (R59) 2" x 4" x 1/2" WELDABLE BEAMS (GRADE A-160)
  - (R60) 2" x 4" x 1/2" WELDABLE BEAMS (GRADE A-160)
  - (R61) 2" x 4" x 1/2" WELDABLE BEAMS (GRADE A-160)
  - (R62) 2" x 4" x 1/2" WELDABLE BEAMS (GRADE A-160)
  - (R63) 2" x 4" x 1/2" WELDABLE BEAMS (GRADE A-160)
  - (R64) 2" x 4" x 1/2" WELDABLE BEAMS (GRADE A-160)
  - (R65) 2" x 4" x 1/2" WELDABLE BEAMS (GRADE A-160)
  - (R66) 2" x 4" x 1/2" WELDABLE BEAMS (GRADE A-160)
  - (R67) 2" x 4" x 1/2" WELDABLE BEAMS (GRADE A-160)
  - (R68) 2" x 4" x 1/2" WELDABLE BEAMS (GRADE A-160)
  - (R69) 2" x 4" x 1/2" WELDABLE BEAMS (GRADE A-160)
  - (R70) 2" x 4" x 1/2" WELDABLE BEAMS (GRADE A-160)
  - (R71) 2" x 4" x 1/2" WELDABLE BEAMS (GRADE A-160)
  - (R72) 2" x 4" x 1/2" WELDABLE BEAMS (GRADE A-160)
  - (R73) 2" x 4" x 1/2" WELDABLE BEAMS (GRADE A-160)
  - (R74) 2" x 4" x 1/2" WELDABLE BEAMS (GRADE A-160)
  - (R75) 2" x 4" x 1/2" WELDABLE BEAMS (GRADE A-160)
  - (R76) 2" x 4" x 1/2" WELDABLE BEAMS (GRADE A-160)
  - (R77) 2" x 4" x 1/2" WELDABLE BEAMS (GRADE A-160)
  - (R78) 2" x 4" x 1/2" WELDABLE BEAMS (GRADE A-160)
  - (R79) 2" x 4" x 1/2" WELDABLE BEAMS (GRADE A-160)
  - (R80) 2" x 4" x 1/2" WELDABLE BEAMS (GRADE A-160)
  - (R81) 2" x 4" x 1/2" WELDABLE BEAMS (GRADE A-160)
  - (R82) 2" x 4" x 1/2" WELDABLE BEAMS (GRADE A-160)
  - (R83) 2" x 4" x 1/2" WELDABLE BEAMS (GRADE A-160)
  - (R84) 2" x 4" x 1/2" WELDABLE BEAMS (GRADE A-160)
  - (R85) 2" x 4" x 1/2" WELDABLE BEAMS (GRADE A-160)
  - (R86) 2" x 4" x 1/2" WELDABLE BEAMS (GRADE A-160)
  - (R87) 2" x 4" x 1/2" WELDABLE BEAMS (GRADE A-160)
  - (R88) 2" x 4" x 1/2" WELDABLE BEAMS (GRADE A-160)
  - (R89) 2" x 4" x 1/2" WELDABLE BEAMS (GRADE A-160)
  - (R90) 2" x 4" x 1/2" WELDABLE BEAMS (GRADE A-160)
  - (R91) 2" x 4" x 1/2" WELDABLE BEAMS (GRADE A-160)
  - (R92) 2" x 4" x 1/2" WELDABLE BEAMS (GRADE A-160)
  - (R93) 2" x 4" x 1/2" WELDABLE BEAMS (GRADE A-160)
  - (R94) 2" x 4" x 1/2" WELDABLE BEAMS (GRADE A-160)
  - (R95) 2" x 4" x 1/2" WELDABLE BEAMS (GRADE A-160)
  - (R96) 2" x 4" x 1/2" WELDABLE BEAMS (GRADE A-160)
  - (R97) 2" x 4" x 1/2" WELDABLE BEAMS (GRADE A-160)
  - (R98) 2" x 4" x 1/2" WELDABLE BEAMS (GRADE A-160)
  - (R99) 2" x 4" x 1/2" WELDABLE BEAMS (GRADE A-160)
  - (R100) 2" x 4" x 1/2" WELDABLE BEAMS (GRADE A-160)

**NOTES:**

1. DUE TO UNUSUAL VERTICAL DIMENSIONS OF NEW CONTRACTOR'S BEAMS, THE CONTRACTOR IS REQUIRED TO OBTAIN THE FINAL LOWER SIDE BY THE ARCHITECT/ENGINEER AND CORRECT TO AVOID A TRIPPING HAZARD.
2. FIELD VERIFY ALL DIMENSIONS PRIOR TO FABRICATION.

1  
S3.3

2  
S3.3

(FOR BEAMS 3 & 4) ADDITIONAL INFORMATION SEE ELEVATION DETAIL A/83.3

**UNIVERSITY OF MIAMI****Civil, Architectural and Environmental Engineering****PROJECT: University of Miami pedestrian bridge****SUBJECT: Deck Design****FPID:****DESIGNED BY:****CHECKED BY:****DATE:**

---

**Description**

This section provides the design for the GFRP RC superstructure deck .

**Contents**

- A. Design loads**
- B. Design of Primary Reinforcement**
  - B1. Input variables**
  - B2. Select Primary Reinforcement and Limits**
  - B3. Negative Moment Region - Flexural Strength at Support**
  - B4. Development Length at Support**
  - B5. Positive Moment Region - Flexural Strength at Middle Span**
  - B6. Development Length at Middle Span**
  - B7. Reinforcement Splices**
- C. Shear Verification**
- D. Crack Width Verification (not required)**
  - D1. Support**
  - D2. Middle Span**
- E. Deflection Verification (not required)**
- F. Summary of Provided Reinforcement**

## A. Design loads

$$L_{\text{span}} := 5.33\text{ft} \quad \text{Span}$$

Maximum positive moment (consider redistribution)

$$\text{Service} \quad M_{\text{pos}} := 0.432\text{kip}\cdot\text{ft}$$

$$\text{Strength} \quad M_{\text{r, pos}} := 0.776\text{kip}\cdot\text{ft}$$

$$\text{Live Load Only} \quad M_{\text{sPos}} := 0.234\text{kip}\cdot\text{ft}$$

Maximum negative moment (no redistribution)

$$\text{Service} \quad M_{\text{neg}} := 0.432\text{kip}\cdot\text{ft}$$

$$\text{Strength} \quad M_{\text{r, neg}} := 0.776\text{kip}\cdot\text{ft}$$

$$\text{Live Load Only} \quad M_{\text{sNeg}} := 0.234\text{kip}\cdot\text{ft}$$

Maximum shear (no redistribution)

$$\omega_{\text{u}} := 12 \cdot \frac{M_{\text{r, neg}}}{L_{\text{span}}^2} = 0.328 \text{ klf} \quad \text{ultimate load}$$

$$\text{Strength} \quad V_{\text{u}} := \omega_{\text{u}} \cdot \frac{L_{\text{span}}}{2} = 0.87 \text{ kip} \quad \text{shear force}$$

## B. Design of Primary Reinforcement

### B1. Input variables



$t_{\text{slab}} := 6\text{in}$	Deck thickness
$c_{\text{c.top}} := 2.65\text{in}$	Top Concrete clear cover
$c_{\text{c.bottom}} := 2\text{in}$	Bottom concrete cover
$N_{\text{top}} := 4$	Top reinforcement bar number.
$N_{\text{bottom}} := 3$	Bottom reinforcement bar number.
$\text{diam}_{N_{\text{top}}} := 0.5\text{in}$	Diameter of top GFRP reinforcement
$\text{diam}_{N_{\text{bottom}}} := 0.375\text{in}$	Diameter of bottom GFRP reinforcement
$\text{area}_{N_{\text{top}}} := 0.196\text{in}^2$	Area of deck primary GFRP reinforcement
$\text{area}_{N_{\text{bottom}}} := 0.11\text{in}^2$	Area of deck primary GFRP reinforcement
$E_f := 7000\text{ksi}$	Modulus of elasticity of deck primary GFRP reinforcement
$f_{fu} := 120\text{ksi}$	Tensile strength of deck primary reinforcement for product certification as reported by GFRP manufacturer [AASHTO GFRP 2009, 2.6.1.2]
$f_{fd} := (f_{fu} \cdot 0.7) = 84 \cdot \text{ksi}$	Design strength of deck primary reinforcement considering reduction for service environment [AASHTO GFRP 2009, 2.6.1.2-1]
$\epsilon_{fu} := 0.018$	GFRP ultimate strain
$\epsilon_{fd} := 0.018 \cdot 0.7 = 0.013$	GFRP design strain
$\epsilon_{cu} := 0.003$	Concrete ultimate strain
$f'_{\text{c.super}} := 5000\text{psi}$	Concrete compressive strength
$f_{\text{r.super}} := 7.5 \sqrt{f'_{\text{c.super}} \cdot \text{psi}} = 530.3 \cdot \text{psi}$	Concrete tensile strength
$\beta_{1.\text{super}} := \begin{cases} 0.85 & \text{if } f'_{\text{c.super}} = 4000\text{psi} \\ 1.05 - 0.05 \cdot \frac{f'_{\text{c.super}}}{1000\text{psi}} & \text{if } 4000\text{psi} < f'_{\text{c.super}} < 8000\text{psi} \\ 0.65 & \text{otherwise} \end{cases} = 0.8$	

$$E_{c.super} := 0.9 \cdot 1820 \cdot \sqrt{f_{c.super} \cdot \text{ksi}} = 3662.7 \cdot \text{ksi}$$

Concrete modulus of elasticity



## B2. Select primary reinforcement and limits



### Preliminary GFRP reinforcement

The failure mode depends on the amount of FRP reinforcement. If  $\rho_f$  is larger than the balanced reinforcement ratio,  $\rho_{fb}$ , then concrete crushing is the failure mode. If  $\rho_f$  is smaller than the balanced reinforcement ratio,  $\rho_{fb}$ , then GFRP rupture is the failure mode.

[AASHTO GFRP 2009, 2.7.4.2-2]

$$\rho_{fb1.slab} := 0.85 \beta_{1.super} \cdot \frac{f_{c.super}}{f_{fd}} \cdot \frac{E_f \cdot \epsilon_{cu}}{E_f \cdot \epsilon_{cu} + f_{fd}} = 0.0081$$

The effective reinforcement depth is:

$$d_{f1.neg} := t_{slab} - c_{c.top} - \frac{\text{diam}_{No_{top}}}{2} = 3.1 \cdot \text{in}$$

$$d_{f1.pos} := t_{slab} - c_{c.bottom} - \frac{\text{diam}_{No_{bottom}}}{2} = 3.81 \cdot \text{in}$$

This reinforcement ratio corresponds to an area of:

$$A_{f\_req1.top} := \rho_{fb1.slab} \cdot 1 \text{ft} \cdot d_{f1.neg} = 0.3 \cdot \text{in}^2 \quad \text{per foot width}$$

$$A_{f\_req1.bottom} := \rho_{fb1.slab} \cdot 1 \text{ft} \cdot d_{f1.pos} = 0.37 \cdot \text{in}^2 \quad \text{per foot width}$$

The corresponding number of GFRP bars is:

$$N_{f\_req1.top} := \frac{A_{f\_req1.top}}{\text{area}_{No_{top}}} = 1.5 \qquad N_{f\_req1.bottom} := \frac{A_{f\_req1.bottom}}{\text{area}_{No_{bottom}}} = 3.4$$

The corresponding spacing is:

$$s_{f\_req1.top} := \frac{1 \text{ft}}{N_{f\_req1.top}} = 7.8 \cdot \text{in} \qquad s_{f\_req1.bottom} := \frac{1 \text{ft}}{N_{f\_req1.bottom}} = 3.6 \cdot \text{in}$$

The number of GFRP bars is:

$$N_{f\_bar1.top} := 2 \qquad N_{f\_bar1.bottom} := 1$$

Therefore, the following bar spacing is selected:

$$s_{f\_bar1.top} := \frac{1\text{ft}}{N_{f\_bar1.top}} = 6\cdot\text{in} \quad s_{f\_bar1.bottom} := \frac{1\text{ft}}{N_{f\_bar1.bottom}} = 12\cdot\text{in}$$

$$\text{Failure\_neg} := \begin{cases} \text{"CONCRETE CRUSHING"} & \text{if } s_{f\_req1.top} \geq s_{f\_bar1.top} \\ \text{"FRP RUPTURE"} & \text{otherwise} \end{cases} = \text{"CONCRETE CRUSHING"}$$

$$\text{Failure\_pos} := \begin{cases} \text{"CONCRETE CRUSHING"} & \text{if } s_{f\_req1.bottom} \geq s_{f\_bar1.bottom} \\ \text{"FRP RUPTURE"} & \text{otherwise} \end{cases} = \text{"FRP RUPTURE"}$$

The minimum required clear bar spacing is:

$$s_{f\_min1.top} := \max(1.5\cdot\text{in}, 1.5 \text{ diam}_{No_{top}}) = 1.5\cdot\text{in} \quad s_{f\_min1.bottom} := \max(1.5\cdot\text{in}, 1.5 \text{ diam}_{No_{bottom}}) = 1.5\cdot\text{in}$$

$$\text{The bar clear spacing is:} \quad s_{f\_bar1.top} - \text{diam}_{No_{top}} = 5.5\cdot\text{in} \quad s_{f\_bar1.bottom} - \text{diam}_{No_{bottom}} = 11.6\cdot\text{in}$$

$$\text{Check\_BarSpacing\_top} := \begin{cases} \text{"VERIFIED"} & \text{if } s_{f\_bar1.top} - \text{diam}_{No_{top}} \geq s_{f\_min1.top} \\ \text{"TOO MANY BARS"} & \text{otherwise} \end{cases}$$

$$\text{Check\_BarSpacing\_bottom} := \begin{cases} \text{"VERIFIED"} & \text{if } s_{f\_bar1.bottom} - \text{diam}_{No_{bottom}} \geq s_{f\_min1.bottom} \\ \text{"TOO MANY BARS"} & \text{otherwise} \end{cases}$$

Check\_BarSpacing\_top = "VERIFIED"

Check\_BarSpacing\_bottom = "VERIFIED"

The area of FRP reinforcement is:

$$A_{f1.neg} := N_{f\_bar1.top} \cdot \text{area}_{No_{top}} = 0.39\cdot\text{in}^2 \quad A_{f1.pos} := N_{f\_bar1.bottom} \cdot \text{area}_{No_{bottom}} = 0.11\cdot\text{in}^2$$

The FRP reinforcement ratio is:

$$\rho_{f1.neg} := \frac{A_{f1.neg}}{1\text{ft} \cdot d_{f1.neg}} = 0.0105 \quad \rho_{f1.pos} := \frac{A_{f1.pos}}{1\text{ft} \cdot d_{f1.pos}} = 0.0024$$

#### Limit for Reinforcement-Minimum Reinforcement

[AASHTO GFRP 2009, 2.9.3.3-1]

$$A_{f.min.slab} := \max(0.33\text{ksi}, 0.16 \cdot \sqrt{f_{c.super}\text{ksi}}) \cdot \frac{1\text{ft} \cdot d_{f1.pos}}{f_{fd}} = 0.2\cdot\text{in}^2$$

$$\text{Check\_FlexureMinReinforcement} := \begin{cases} \text{"VERIFIED"} & \text{if } A_{f1.neg} \geq A_{f.min.slab} \wedge A_{f1.pos} \geq A_{f.min.slab} \\ \text{"NOT VERIFIED"} & \text{otherwise} \end{cases}$$

Check\_FlexureMinReinforcement = "VERIFIED"

The slab using GFRP is chosen to be over-reinforced, which means that failure of the component is initiated by crushing of the concrete. The strength reduction factor  $\phi_{f\_bar1.slab}$  is:

[AASHTO GFRP 2009, 2.9.2.1]

$$\phi_{f\_bar1.neg} := \begin{cases} 0.55 & \text{if } \rho_{f1.neg} \leq \rho_{fb1.slab} \\ 0.3 + 0.25 \cdot \frac{\rho_{f1.neg}}{\rho_{fb1.slab}} & \text{if } \rho_{fb1.slab} \leq \rho_{f1.neg} \leq 1.4 \cdot \rho_{fb1.slab} \\ 0.65 & \text{if } \rho_{f1.neg} \geq 1.4 \cdot \rho_{fb1.slab} \end{cases} = 0.63$$

$$\phi_{f\_bar1.pos} := \begin{cases} 0.55 & \text{if } \rho_{f1.pos} \leq \rho_{fb1.slab} \\ 0.3 + 0.25 \cdot \frac{\rho_{f1.neg}}{\rho_{fb1.slab}} & \text{if } \rho_{fb1.slab} \leq \rho_{f1.pos} \leq 1.4 \cdot \rho_{fb1.slab} \\ 0.65 & \text{if } \rho_{f1.pos} \geq 1.4 \cdot \rho_{fb1.slab} \end{cases} = 0.55$$



### B3. Negative moment region - flexural strength at support



$N_{o\_top} = 4$	Deck primary reinforcement bar number.
$diam_{N_{o\_top}} = 0.5 \cdot \text{in}$	Diameter of deck primary GFRP reinforcement
$area_{N_{o\_top}} = 0.196 \cdot \text{in}^2$	Area of deck primary GFRP reinforcement
$N_{f\_bar1.top} = 2$	Number of GFRP bars per foot width for negative moment
$A_{f1.neg} = 0.392 \cdot \text{in}^2$	Area of GFRP bars per foot width for negative moment
$M_{r.neg} = 0.776 \cdot \text{kip} \cdot \text{ft}$	Maximum negative moment demand
$f_{fd} = 84 \cdot \text{ksi}$	Design strength of deck primary reinforcement considering reduction for service environment

The maximum tensile stress in the GFRP is computed:

[AASHTO GFRP 2009, 2.9.3.1-1]

$$f_{f1.neg} := \begin{cases} \sqrt{\frac{[(E_f \cdot \epsilon_{cu})^2]}{4} + \frac{0.85 \beta_{1.super} \cdot f_{c.super}}{\rho_{f1.neg}} E_f \cdot \epsilon_{cu} - 0.5(E_f \cdot \epsilon_{cu})} & \text{if } \rho_{f1.neg} \geq \rho_{fb1.slab} \\ f_{fu} & \text{otherwise} \end{cases}$$

$$f_{fl.neg} = 72.5 \cdot \text{ksi} \quad \text{effective stress}$$

$$f_{fd} = 84 \cdot \text{ksi} \quad \text{design stress}$$

The stress-block depth is computed as per Eq.2.9.3.2.2-2 or Eq.2.9.3.2.2-4 whether  $\rho_f > \rho_{fb}$  or  $\rho_f < \rho_{fb}$ , respectively.

$$a_{fl.neg} := \frac{A_{fl.neg} \cdot f_{fl.neg}}{0.85 \cdot f_{c.super} \cdot 1 \text{ft}} = 0.56 \cdot \text{in} \quad [\text{AASHTO GFRP 2009, 2.9.3.2.2-2}]$$

Neutral axis depth  $c_b$  at balanced strain conditions:

$$c_{b1.neg} := \left( \frac{\epsilon_{cu}}{\epsilon_{cu} + \epsilon_{fu}} \right) \cdot d_{fl.neg} = 0.4 \cdot \text{in} \quad [\text{AASHTO GFRP 2009, 2.9.3.2.2-4}]$$

The nominal moment capacity is: [AASHTO GFRP 2009, 2.9.3.2.2-1, 2.9.3.2.2-3]

$$M_{n\text{AASHTO}_1.neg} := \begin{cases} A_{fl.neg} \cdot f_{fl.neg} \cdot \left( d_{fl.neg} - \frac{a_{fl.neg}}{2} \right) & \text{if } \rho_{fl.neg} \geq \rho_{fb1.slabb} \\ A_{fl.neg} \cdot f_{fl.neg} \cdot \left( d_{fl.neg} - \frac{\beta_{1.super} \cdot c_{b1.neg}}{2} \right) & \text{otherwise} \end{cases}$$

$$M_{n\text{AASHTO}_1.neg} = 6.7 \cdot \text{kip} \cdot \text{ft}$$



Recall the strength reduction factor for slab:

[AASHTO GFRP 2009, 2.12.1.2.1]

$$\phi_{f\_bar1.neg} = 0.63$$

The design flexural strength is computed as:

$$\phi_{f\_bar1.neg} \cdot M_{n\text{AASHTO}_1.neg} = 4 \cdot \text{kip} \cdot \text{ft}$$

$$\text{Recall } M_{r.neg} = 0.776 \cdot \text{kip} \cdot \text{ft}$$

$$\text{Check\_SlabFlexureAASHTO}_1 := \begin{cases} \text{"VERIFIED"} & \text{if } \phi_{f\_bar1.neg} \cdot M_{n\text{AASHTO}_1.neg} \geq M_{r.neg} \\ \text{"NOT VERIFIED"} & \text{otherwise} \end{cases}$$

Check\_SlabFlexureAASHTO\_1 = "VERIFIED"



#### B4. Development length at support



#### B5. Positive moment region - flexural strength at middle span





$N_{o\_bottom} = 3$	Deck primary reinforcement bar number.
$diam_{N_{o\_bottom}} = 0.38 \cdot \text{in}$	Diameter of deck primary GFRP reinforcement
$area_{N_{o\_bottom}} = 0.11 \cdot \text{in}^2$	Area of deck primary GFRP reinforcement
$N_{f\_bar1.bottom} = 1$	Number of GFRP bars per foot width for positive moment
$A_{f1.pos} = 0.11 \text{ in}^2$	Area of GFRP bars per foot width for positive moment
$d_{f1.pos} = 3.812 \text{ in}$	The effective reinforcement depth
$s_{f\_bar1.bottom} = 12 \text{ in}$	The reinforcing spacing
$M_{r.pos} = 0.776 \cdot \text{kip} \cdot \text{ft}$	Maximum positive moment demand

GFRP reinforcement ratio is:

$$\rho_{f1.pos} = 0.002$$

The balanced reinforcement ratio,  $\rho_{fb}$  is

[AASHTO GFRP 2009, 2.7.4.2-2]

$$\rho_{fb1.pos} := 0.85\beta_{1.super} \cdot \frac{f_{c.super}}{f_{fd}} \cdot \frac{E_f \cdot \epsilon_{cu}}{E_f \cdot \epsilon_{cu} + f_{fd}} = 0.008$$

The maximum tensile stress in the GFRP is:

[AASHTO GFRP 2009, 2.9.3.1-1]

$$f_{f1.pos} := \begin{cases} \sqrt{\frac{(E_f \cdot \epsilon_{cu})^2}{4} + \frac{0.85\beta_{1.super} \cdot f_{c.super}}{\rho_{f1.pos}} E_f \cdot \epsilon_{cu}} - 0.5 E_f \cdot \epsilon_{cu} & \text{if } \rho_{f1.pos} \geq \rho_{fb1.pos} \\ f_{fd} & \text{otherwise} \end{cases}$$

$$f_{f1.pos} = 84 \cdot \text{ksi}$$

The stress-block depth is computed as per Eq.2.9.3.2.2-2 or Eq.2.9.3.2.2-4 whether  $\rho_f > \rho_{fb}$  or  $\rho_f < \rho_{fb}$ , respectively.

$$a_{f1.pos} := \frac{A_{f1.pos} \cdot f_{f1.pos}}{0.85 \cdot f_{c.super} \cdot 1 \text{ ft}} = 0.18 \cdot \text{in} \quad [\text{AASHTO GFRP 2009, 2.9.3.2.2-2}]$$

Neutral axis depth  $c_b$  at balanced strain conditions:

$$c_{b1.pos} := \left( \frac{\epsilon_{cu}}{\epsilon_{cu} + \epsilon_{fd}} \right) \cdot d_{f1.pos} = 0.7 \cdot \text{in} \quad [\text{AASHTO GFRP 2009, 2.9.3.2.2-4}]$$

The nominal moment capacity is: [AASHTO GFRP 2009, 2.9.3.2.2-1, 2.9.3.2.2-3]

$$M_{n\text{AASHTO}_1.pos} := \begin{cases} A_{f1.pos} \cdot f_{f1.pos} \cdot \left( d_{f1.pos} - \frac{a_{f1.pos}}{2} \right) & \text{if } \rho_{f1.pos} \geq \rho_{fb1.pos} \\ A_{f1.pos} \cdot f_{f1.pos} \cdot \left( d_{f1.pos} - \frac{\beta_{1.super} \cdot c_{b1.pos}}{2} \right) & \text{otherwise} \end{cases}$$

$$M_{n\text{AASHTO}_1.pos} = 2.7 \cdot \text{kip} \cdot \text{ft}$$



The strength reduction factor is computed as follows:

[AASHTO GFRP 2009, 2.7.4.2-1]

$$\phi_{f\_bar1.pos} = 0.55$$

The design flexural strength, equation, is computed as:

$$\phi_{f\_bar1.pos} \cdot M_{n\text{AASHTO}_1.pos} = 1 \cdot \text{kip} \cdot \text{ft}$$

Recall  $M_{r.pos} = 0.776 \cdot \text{kip} \cdot \text{ft}$

$$\text{Check\_SlabFlexureAASHTO}_2 := \begin{cases} \text{"VERIFIED"} & \text{if } \phi_{f\_bar1.pos} \cdot M_{n\text{AASHTO}_1.pos} \geq M_{r.pos} \\ \text{"NOT VERIFIED"} & \text{otherwise} \end{cases}$$

Check\_SlabFlexureAASHTO\_2 = "VERIFIED"



## B6. Development length at middle span



**B7. Reinforcement Splices** not necessary having a short span



## C. Shear Verification



The nominal shear resistance provide by concrete,  $V_c$

$$c_{1.neg} := \frac{a_{f1.neg}}{\beta_{1.super}} = 0.7 \cdot \text{in} \quad \text{neutral axis depth at support}$$

$$c_{1.pos} := \frac{a_{f1.pos}}{\beta_{1.super}} = 0.2 \cdot \text{in} \quad \text{neutral axis depth at middle span}$$

$$V_{c1.slab} := 0.16 \sqrt{f_{c.super} \cdot \text{ksi} \cdot 1 \text{ ft} \cdot c_{1.neg}} = 3 \cdot \text{kip} \quad [\text{AASHTO GFRP 2009, 2.7.4.2}]$$

Resistance factor  $\phi_v$  for shear is 0.75 [AASHTO GFRP 2009, 2.7.4.2]

$$V_r := 0.75 \cdot V_{c1.slab} = 2.2 \text{ kip} \quad \text{factored shear strength}$$

$$V_u = 0.9 \text{ kip} \quad \text{ultimate shear force}$$

Check\_shear :=  $\begin{cases} \text{"VERIFIED"} & \text{if } V_r \geq V_u \\ \text{"NOT VERIFIED"} & \text{otherwise} \end{cases}$

Check\_shear = "VERIFIED"



## D. Crack Width Verification

### D1. Support



### D3. Middle Span



## E. Deflection Verification

### Preliminary Calculations



#### Cracked Moment of Inertia



#### Effective Moment of Inertia



#### Maximum Deflection



## F. Summary of Reinforcement Provided and Detailing

### Primary reinforcement perpendicular to pedestrian traffic



$No_{top} = 4$  Bar number of top primary reinforcement

$s_{f\_bar1.top} = 6\text{-in}$  Top spacing

$c_{c.top} = 2.7\text{ in}$  Top cover





$No_{bottom} = 3$  Bar number of bottom primary reinforcement

$s_{f\_bar1.top} = 6\text{-in}$  Bottom spacing

$c_{c.bottom} = 2\text{ in}$  Bottom cover

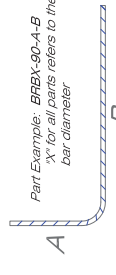
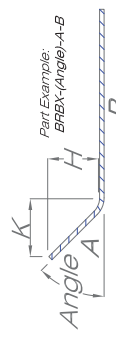
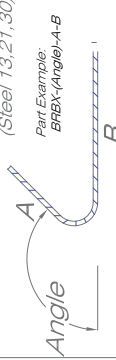
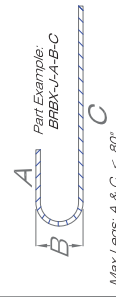
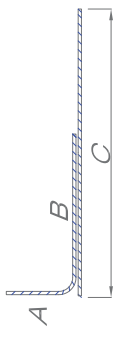
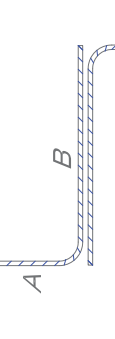
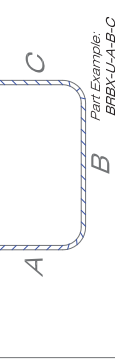
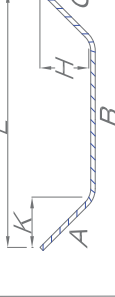
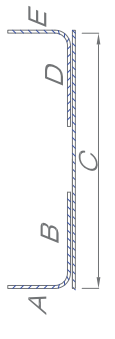
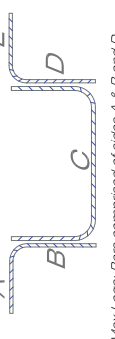
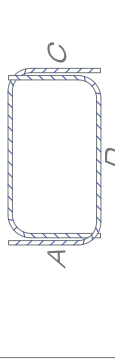

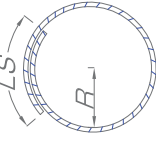
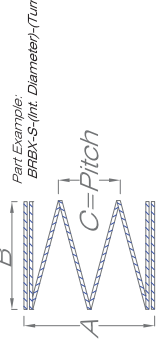
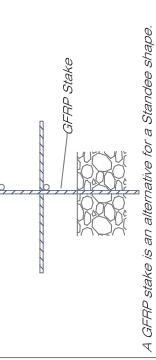
**APPENDIX D:**  
**STANDARD GFRP BAR BENDS**

<b>GFRP Bar Bends (Bar Sizes #2 - #8) (8-6-13)</b>			
<p><b>G1-90 Deg Bent (Steel 2, 17)</b></p>  <p>Part Example: BRBX-90-A-B X: For all parts refers to the imperial bar diameter.</p> <p>Max Legs: A ≤ 80"; B may be up to 80" If A ≤ 50"; B may be up to 90" If A ≤ 30"; B may be up to 105"</p>	<p><b>G2-&gt;90 Deg Bent (Steel 3)</b></p>  <p>Part Example: BRBX-(Angle)-A-B</p> <p>Max Total Linear Length: If Angle between 25 &amp; 25 Degrees: 110" If Angle between 25 &amp; 45 Degrees: 115" If Angle between 45 &amp; 65 Degrees: 120" If Angle between 65 &amp; 85 Degrees: 130"</p>	<p><b>G3-&lt;90 Deg Bent (Steel 13, 21, 30)</b></p>  <p>Part Example: BRBX-(Angle)-A-B</p> <p>Max Total Linear Length: If Angle between 05 &amp; 115 Degrees: 130" If Angle between 115 &amp; 135 Degrees: 120" If Angle between 135 &amp; 155 Degrees: 115" If Angle between 155 &amp; 175 Degrees: 110"</p>	<p><b>G4-Hooked Bar (Steel 1)</b></p>  <p>Part Example: BRBX-J-A-B-C</p> <p>Max Legs: A &amp; C ≤ 80" B: 3" for #2 Bar 4.5" for #3 through #6 bar 6" for #7 &amp; #8 bar</p> <p>Note: A 90 Deg bend with a 1/2 bar diameter tail is equally effective and more economical.</p>
<p><b>G5-Long Leg Bent (Steel 2, 17)</b></p>  <p>Max Legs: Bar comprised of sides A &amp; B can be shapes G1, G2, or G3 Straight bar (C) can be produced up to 60 ft long. Bars sold individually.</p>	<p><b>G6-Z Bar or Similar (Steel 8, 18, 19, 20, 24, 29)</b></p>  <p>Max Legs: Both bars can be shapes G1, G2, or G3 Bars sold individually.</p>	<p><b>G7-U/C Shape Bar (Steel 2/17)</b></p>  <p>Part Example: BRBX-U-A-B-C</p> <p>Max Legs: For B &lt; 40", A&amp;C can be up to 45" each For 40" &lt; B &lt; 80", A&amp;C can be up to 40" each For 80" &lt; B &lt; 96", A&amp;C can be up to 20" each</p>	<p><b>G8-Open U (Steel 3d, 4c, 14ab, 22b)</b></p>  <p>Part Example: BRBX-U"-A-B-C</p> <p>Max Part Lengths: L can be up to 80" H can be up to 45"</p>
<p><b>G9-Long Leg U (Steel 2/17)</b></p>  <p>Max Legs: Bars comprised of sides A &amp; B and D &amp; E can be shapes G1, G2, or G3 Straight bar (C) can be produced to length Bars sold individually.</p>	<p><b>G10-Gull Wing (Steel 3, 4, 7, 22, 23)</b></p>  <p>Max Legs: Bars comprised of sides A &amp; B and D &amp; E can be shapes G1, G2, or G3 Bar comprised of sides B, C, &amp; D can be shapes G7 or G8 Bars sold individually.</p>	<p><b>G11-Closed Stirrup (Steel s3, T1, T2)</b></p>  <p>Max Legs: Both individual bars conform to shape G7 Bars sold individually.</p>	<p><b>G12-Large Radius (Steel 9)</b></p> 
<p><b>G13-Hoop (Steel T3)</b></p>  <p>Max Size: 6" ≤ R ≤ 48"</p> <p>Part Example: BRBX-H-(Int. Diameter)-(LS)</p>	<p><b>G14-Spiral (Steel SP1)</b></p>  <p>Part Example: BRBX-S-(Int. Diameter)-(Turns)</p> <p>Max Size: B conforms to shape G13 Number of turns can be up to 80</p>	<p><b>G15-Stake (Steel 25, 26 alternative)</b></p>  <p>A GFRP stake is an alternative for a Standee shape. While a standee is possible, a GFRP stake is a much more economical solution and is preferred. Bar can be directly embedded into the ground and will not corrode.</p>	<p><b>G15-Stake (Steel 25, 26 alternative)</b></p> 

APPENDIX E:

STATE OF THE ART: GFRP RC RAILINGS AND BARRIERS

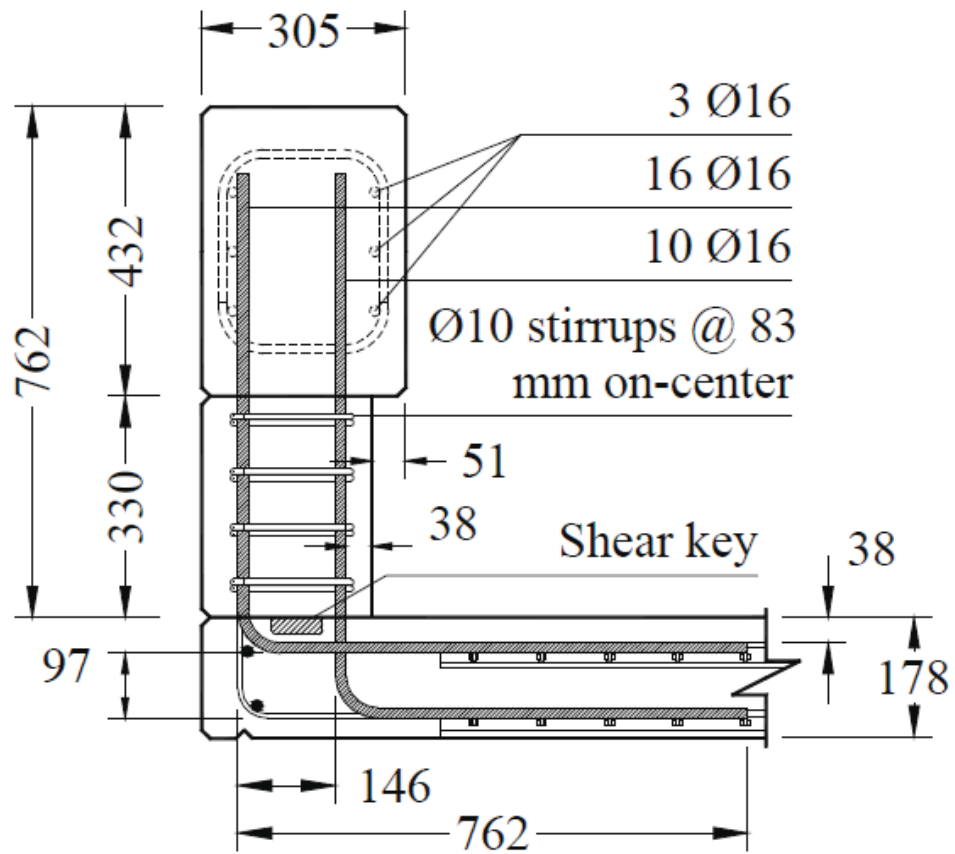

E.1 - Open-post railings. Bridge 14802301 in Greene County, Missouri, USA, 2007

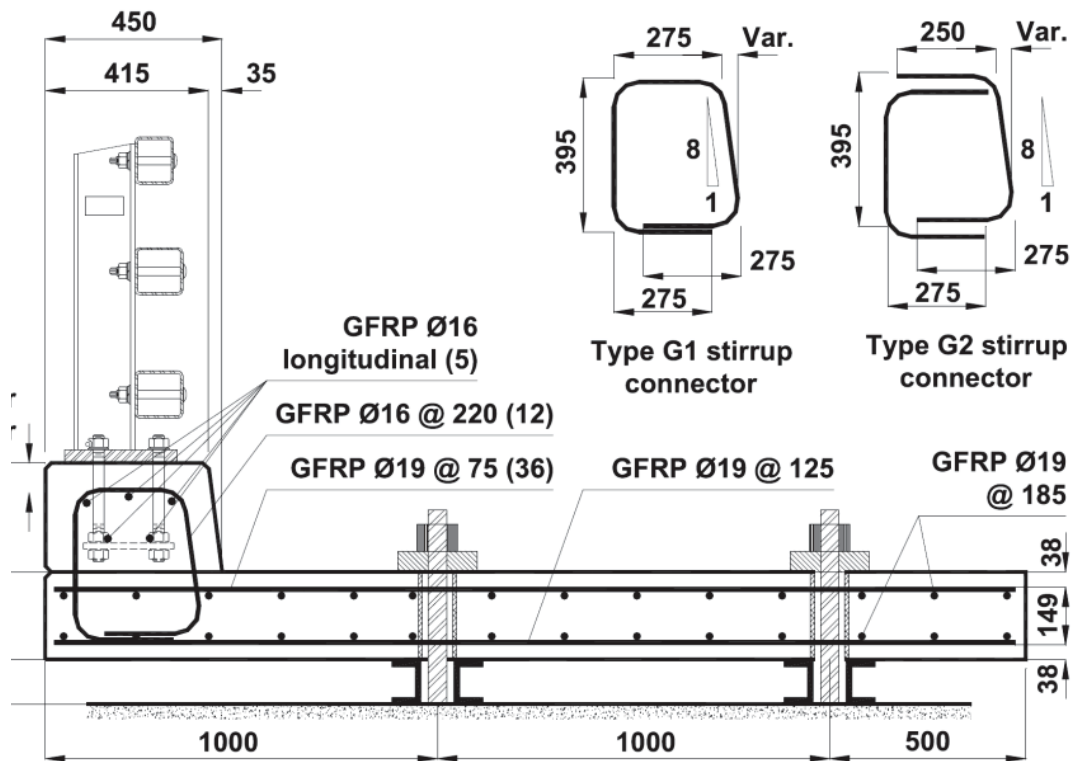

E.2 - Steel post-and-beam barrier with reinforced GFRP curb prototype, 2013



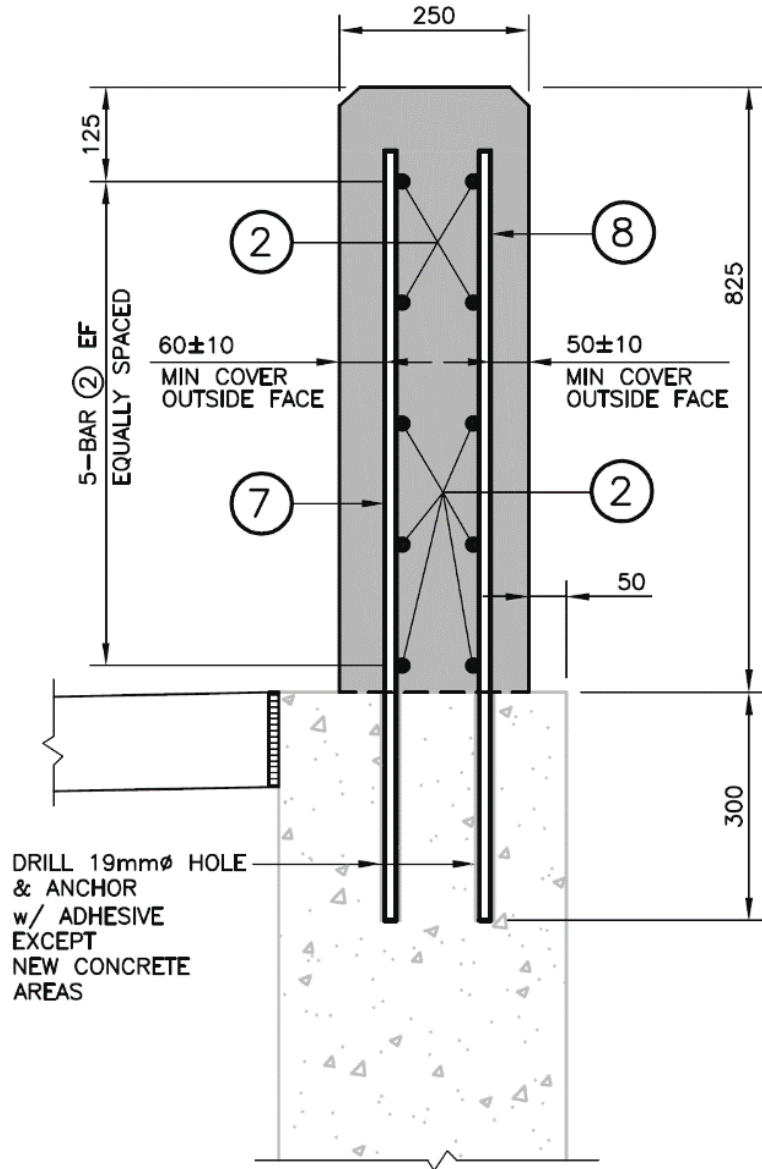

E.3 - Vertical face parapet. John Street CNR Overhead Bridge, Ontario, 2012

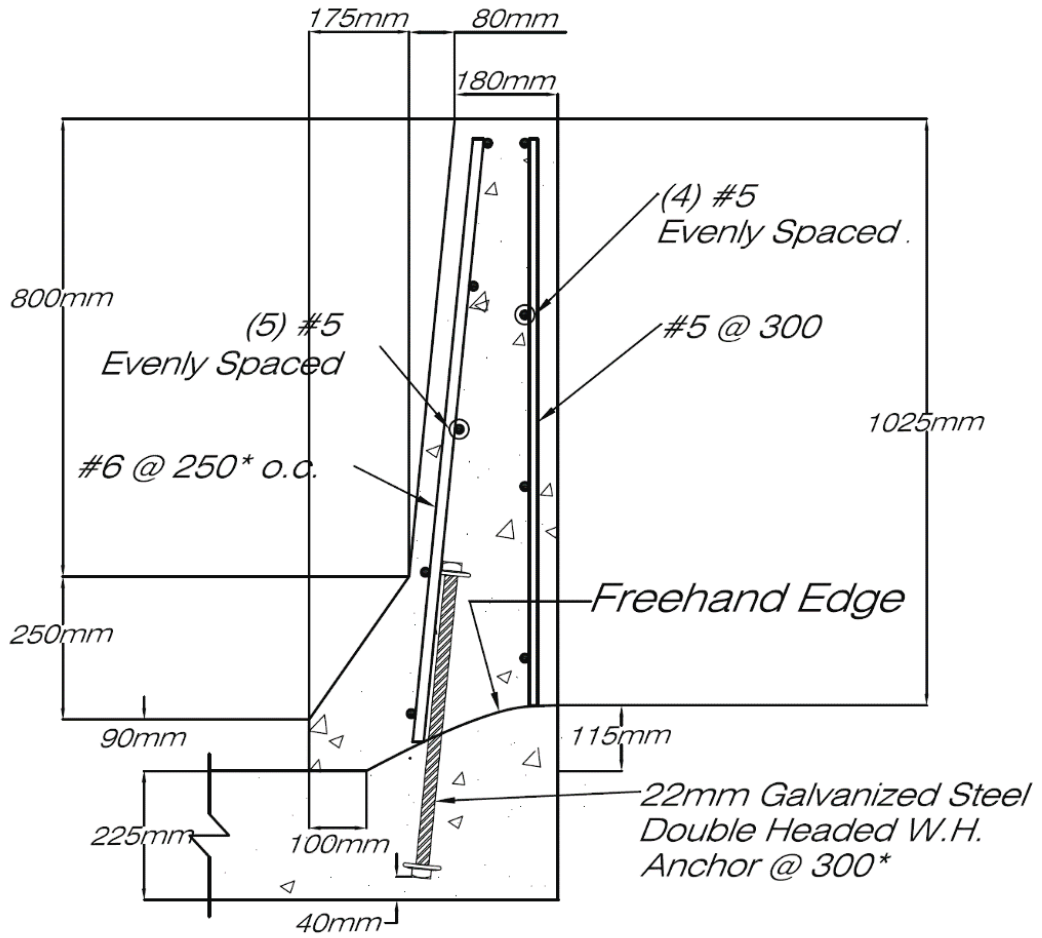

E.4 - Safety shaped parapet with straight bars. Clark's Mill Bridge, Prince County, Canada, 2007

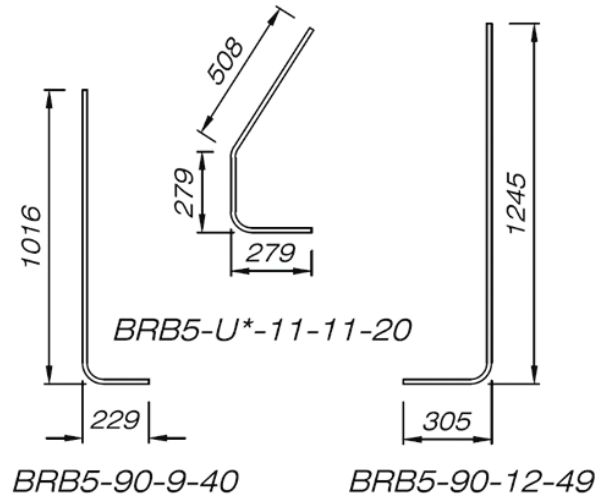
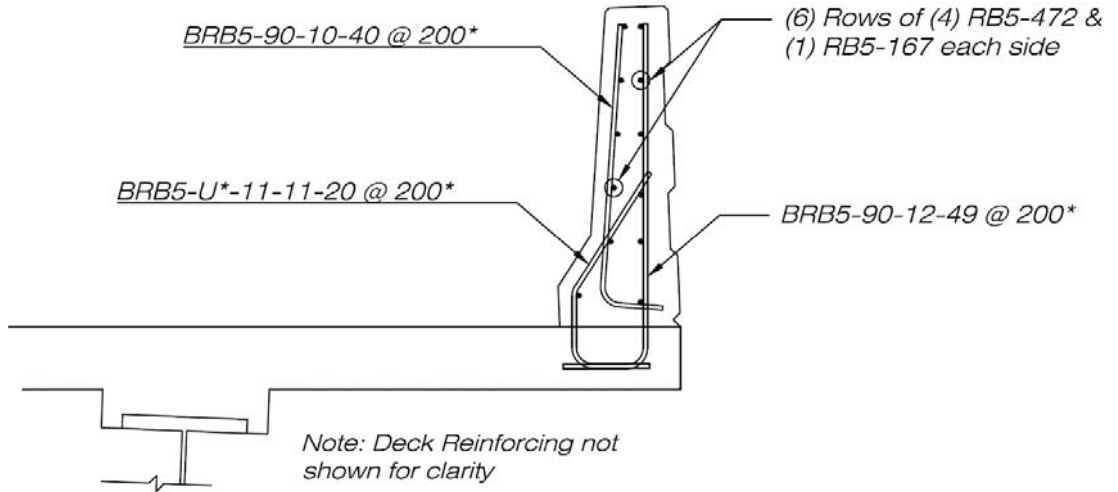

E.5 - Safety shaped parapets with bent bars, Ross Corner Bridge traffic Barriers, 2011.

SECTION THRU NEW JERSEY SHAPE RAILING (FDDT 2014)  
 TL-3 AND TL-4 (SHEAR REINFORCEMENT REQUIRED)

ALL THE REINFORCEMENT DIMENSIONS VARY ACCORDING TO DESIGN REQUIREMENTS.

NET TO SCALE  
 UNITS IN INCHES G IN = 25.4 MM

FDDT LRFD #2A DESIGN EXAMPLE  
 UNIVERSITY OF MIAMI  
 CBRAL GABLES

ANTONIO NANNI, PROFESSOR AND CHAIR  
 VALENTINO RINALDI, MS  
 GUILLELMO CLUARE, PHD CANDIDATE

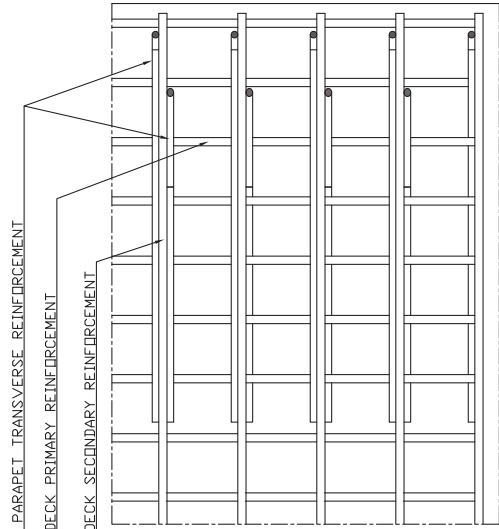
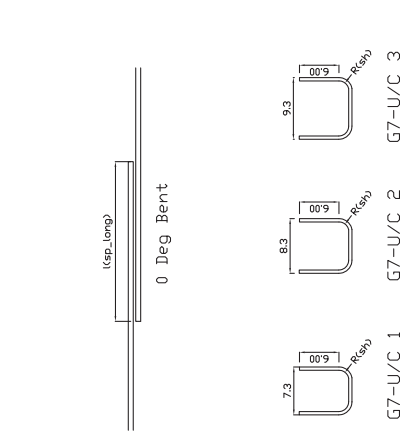
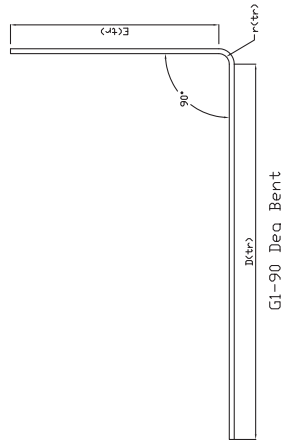
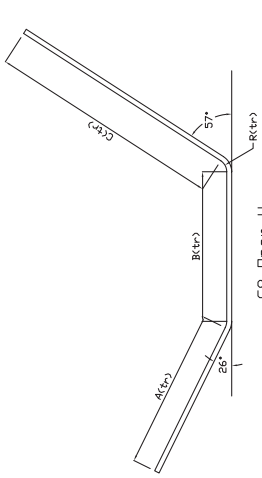
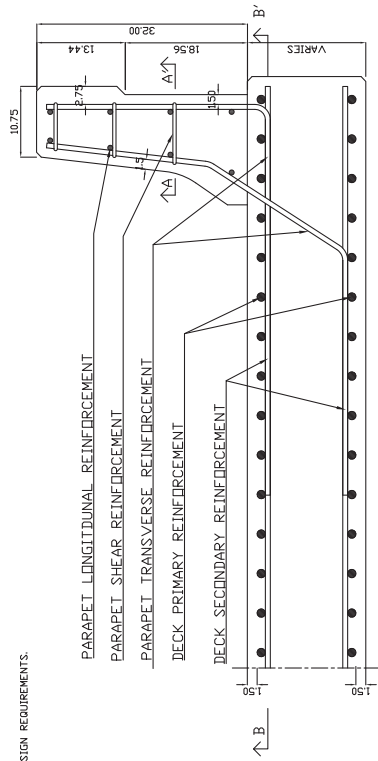

SECTION B - B'

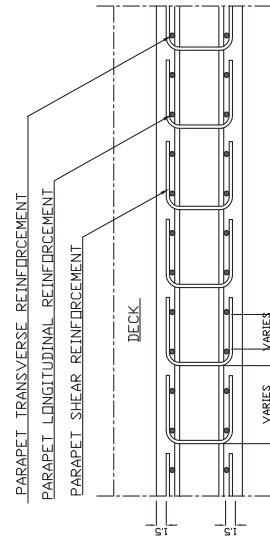

SECTION A - A'

## VITA

Valentino Rinaldi was born in Rieti, Italy on April 14, 1990. Valentino received his primary and secondary education in Rieti. In 2009 he entered La Sapienza, University of Rome (Italy), where he received his Bachelor of Science in Architectural engineering, with honors in January, 2013. In the academic year 2013-14 he attended the International Master course of Civil Engineering, at the University of Bologna. In 2014-2015 he was enrolled in the Dual Degree Program with the University of Miami, where he attended the second year of Master. In August, 2015, he received his Master in Civil Engineering from the University of Miami.

*Permanent address: Via Borgo Provaroni 110, 02018 Poggio Bustone (RI), Italy*