

2010-01-15

A Transdiagnostic Model of Suicidal Ideation and Suicide Attempts

Lori Rachel Eisner

University of Miami, leisner@partners.org

Follow this and additional works at: https://scholarlyrepository.miami.edu/oa_dissertations

Recommended Citation

Eisner, Lori Rachel, "A Transdiagnostic Model of Suicidal Ideation and Suicide Attempts" (2010). *Open Access Dissertations*. 358.
https://scholarlyrepository.miami.edu/oa_dissertations/358

This Open access is brought to you for free and open access by the Electronic Theses and Dissertations at Scholarly Repository. It has been accepted for inclusion in Open Access Dissertations by an authorized administrator of Scholarly Repository. For more information, please contact repository.library@miami.edu.

UNIVERSITY OF MIAMI

A TRANSDIAGNOSTIC MODEL OF SUICIDAL IDEATION
AND SUICIDE ATTEMPTS

By

Lori R. Eisner

A DISSERTATION

Submitted to the Faculty
of the University of Miami
in partial fulfillment of the requirements for
the degree of Doctor of Philosophy

Coral Gables, Florida

May 2010

©2010
Lori R. Eisner
All Rights Reserved

UNIVERSITY OF MIAMI

A dissertation submitted in partial fulfillment of
the requirements for the degree of
Doctor of Philosophy

A TRANSDIAGNOSTIC MODEL OF SUICIDAL IDEATION
AND SUICIDE ATTEMPTS

Lori R. Eisner

Approved:

Charles S. Carver, Ph.D.
Distinguished Professor of Psychology

Terri A. Scandura, Ph.D.
Dean of the Graduate School

Jutta Joormann, Ph.D.
Associate Professor of Psychology

Maria Llabre, Ph.D.
Professor of Psychology

Matthias Siemer, Ph.D.
Assistant Professor of Psychology

Krysia Mossakowski, Ph.D.
Assistant Professor of Sociology

Sheri L. Johnson, Ph.D.
Adjunct Professor of Psychology

EISNER, LORI R.

(Ph.D., Psychology)

A Transdiagnostic Model of Suicidal Ideation
and Suicide Attempts

(May 2010)

Abstract of a dissertation at the University of Miami.

Dissertation supervised by Professor Sheri L. Johnson.

No. of pages in text. (106)

Suicide is one of the most tragic issues in mental health. Suicide has traditionally been studied as an outcome of specific psychiatric disorders. The goal of this study was to consider whether there might be underlying dimensions across psychiatric disorders that are related to suicidality. This study proposed a transdiagnostic model of suicidality. Psychiatric symptoms were hypothesized to load onto three factors: Negative Mood, Impulsivity, and Arousal. Factors were then examined as predictors of suicidal ideation and suicide attempts. Data were drawn from the National Comorbidity Survey-Replication Study (NCS-R). Structured interviews were conducted in two parts using the Composite International Diagnostic Interview (CIDI). All survey respondents ($N = 9,282$) were administered the core diagnostic assessment. Those who met criteria for a psychiatric disorder, met subthreshold lifetime criteria and sought treatment at some time in their life, or ever in their life made a plan to commit or attempt suicide were administered Part II of the interview and are the sample of interest in this study ($N = 5,692$). The sample was representative of non-institutionalized civilian adults ages 18 or older whose primary language was English. Factor analyses revealed three modified factors: a Negative Mood/Emotional Arousal factor, a Negative Thinking factor, and a Recurrent Substance Use factor. Negative Mood/Emotional Arousal was a strong

predictor of suicidal ideation. Suicidal ideation mediated the relationship between Negative Mood/Emotional Arousal and suicide attempts, controlling for Negative Thinking. Negative Thinking, Recurrent Substance Use, and suicidal ideation predicted suicide attempts. When number of suicide attempts was examined as the dependent variable, the model did not fit the data, suggesting that these factors were not as helpful in predicting highly recurrent suicide attempts. Recurrent Substance Use moderated the relationship between Negative Mood/Emotional Arousal and suicide attempts, demonstrating that, as negative mood increases, people with high levels of recurrent substance use are more likely to make a suicide attempt compared to people with mean or low levels of recurrent substance use. In sum, results of this study support two distinct pathways to making a suicide attempt: a direct relationship between negative thinking and suicide attempts, as well as an interaction between negative mood/emotional arousal and recurrent substance use. Several limitations including issues of sampling, the cross-sectional nature of the data, self-report bias, and the structure of the CIDI instrument, were taken into account in interpreting the results. Clinical implications and future directions for research are discussed.

ACKNOWLEDGEMENTS

I would like to express my deepest gratitude to my mentor, Sheri Johnson, Ph.D. For the past five years she has encouraged me to ask important questions, cultivated my research ideas, and guided me in seeking and understanding the answers. This dissertation exemplifies my growth and development as a scholar under her mentorship.

I am grateful to the members of my dissertation committee for their insight and feedback. A special thank you to Charles Carver, Ph.D., for graciously serving as chairperson and to Maria Llabre, Ph.D., for her enthusiasm and statistical support.

I also would like to thank the NIMH Collaborative Psychiatric Epidemiology Surveys Initiative for collecting and compiling a valuable and rich dataset.

This dissertation is the culmination of my five years of graduate study in the Department of Psychology at the University of Miami. I am thankful for the department's investment in me and contribution to the strong foundation upon which I will continue to develop my career and self.

None of this, of course, would have been possible without my parents' unconditional love, my brother's competitive spirit, and my husband's unwavering faith in me.

TABLE OF CONTENTS

	Page
LIST OF TABLES	vi
LIST OF FIGURES	vii
Chapter	
1 INTRODUCTION	1
Prevalence of Completed Suicide, Attempted Suicide, and Suicidal Ideation.....	1
Risk Factors	1
A Transdiagnostic Model.....	4
Negative Mood.....	7
Impulsivity	15
Arousal.....	21
Statement of Problem.....	24
Hypotheses.....	26
2 METHOD	28
Overview of National Comorbidity Survey Replication Methods	28
Interviewers.....	28
Sample.....	29
Measures	31
Overview of Statistical Analyses	33
Missing Data	35
3 RESULTS	38
Negative Mood Confirmatory Factor Analysis.....	38
Impulsivity Confirmatory Factor Analysis	39
Arousal Confirmatory Factor Analysis.....	40
Combined Model	41
Structural Equation Modeling.....	42
Comparison of Negative Thinking with Hopelessness.....	45
Moderation Analyses	46
4 DISCUSSION	48
Limitations	49
Latent Variables	52
Predictors of Suicidal Ideation.....	57
Predictors of Suicide Attempts	57
Future Directions	60
Clinical Implications.....	61

REFERENCES.....	64
TABLES.....	82
FIGURES.....	94

LIST OF TABLES

	Page
Table 1 Prevalence of 12-Month Mental Disorders Among Respondents with 12-Month Suicidal Ideation and Attempts	82
Table 2 Odds Ratios for Lifetime DSM-III and 12-Month DSM-IV Disorders with Lifetime and 12-Month Suicidal Ideation and Attempts	84
Table 3 Summary of Composite Variables and Missing Data.....	86
Table 4 Correlations and Partial Correlations of Factor Scores with Suicidal Ideation and Suicide Attempt.....	92
Table 5 Moderation of Negative Mood/Emotional Arousal as a Predictor of Suicide Attempts by Recurrent Substance Use.....	93

LIST OF FIGURES

	Page
Figure 1 Hypothesized measurement model of Negative Mood, Impulsivity, and Arousal.....	95
Figure 2 Proposed mediation model	96
Figure 3 Proposed full structural equation model relating Negative Mood, Impulsivity, and Arousal to Suicidal Ideation and Suicide Attempts	97
Figure 4 Measurement model for Negative Mood and Negative Thinking.....	98
Figure 5 Measurement model for Recurrent Substance Use	99
Figure 6 Measurement model for Negative Emotional Arousal.....	100
Figure 7 Measurement model for Negative Mood/Emotional Arousal and Negative Thinking.....	101
Figure 8 Measurement model for Negative Mood/Emotional Arousal, Negative Thinking, and Recurrent Substance Use	102
Figure 9 Structural equation model examining Negative Mood/Emotional Arousal and Negative Thinking as predictors of Suicidal Ideation	103
Figure 10 Structural equation model examining Negative Mood/Emotional Arousal and Negative Thinking as predictors of Suicide Attempts	104
Figure 11 Structural equation model demonstrating mediation by Suicidal Ideation .	105
Figure 12 Full Structural Equation Model.....	106

Chapter 1: Introduction

Prevalence of Completed Suicide, Attempted Suicide, and Suicidal Ideation

Completed suicide, suicide attempts, and suicidal ideation are all too prevalent. Suicide was the eleventh leading cause of death among Americans, accounting for 1.3% of all deaths in the United States in 2005 (Center for Disease Control, 2008). The rate of completed suicide has been estimated at 11 deaths per 100,000 people, totaling more than 32,000 deaths each year in the United States. For every completed suicide, about 25 attempts are made (Holmes & Holmes, 2005), with 2-5% of people attempting suicides during their lifetime (Kessler, Borges, & Walters, 1999; Moscicki, 2001). As a result, suicide-related injury is common, and approximately 425,000 people each year are treated in emergency rooms following a suicide attempt. Many more people think about suicide during their lifetime, with estimates as high as 14% (Kessler et al., 1999). Given the prevalence of suicidality, much research has been devoted to identifying who is at risk for making a suicide attempt.

Risk factors

Several factors have been identified as important risk factors for suicidality. It is well established that certain demographic characteristics are risk factors for completed suicide, specifically older age, male gender, lower socioeconomic status, and a single, divorced, separated, or widowed marital status (Holmes & Holmes, 2005; Moscicki, 1997). A history of suicide attempts is one of the strongest risk factors for completed suicide (Moscicki, 1997). In contrast to completed suicide, suicide attempts are predicted by female gender regardless of race or ethnicity (Moscicki, 1994) and having a previous history of suicide attempts (Borges et al., 2006; Borges, Angst, Nock, Ruscio, & Kessler,

2008; Oquendo, Lizardi, Greenwald, Weissman, & Mann, 2004). Although sociodemographic variables and history of suicidal behaviors have been identified as key risk variables, they explain only a small percentage of variance, and therefore do not provide enough information to meaningfully determine who is likely to experience suicidal ideation, attempts, or death.

Beyond demographic risk factors and a history of suicide-related behaviors, psychiatric disorders are commonly present among people who think about, attempt, and complete suicide (Harris & Barraclough, 1997; Joiner, Brown, & Wingate, 2005; Kessler et al., 1999) (Table 1). In the National Comorbidity Survey and its replication study, at least 80% of ideators and 88% of attempters met criteria for a DSM disorder within the past 12 months (Kessler, Berglund, Borges, Nock, & Wang, 2005). Studies of specific psychiatric disorders suggest that mood, personality, and substance use disorders are particularly associated with higher rates of suicide. In an epidemiological sample 61% of people with suicidal ideation were diagnosed with an anxiety disorder, 61% of people with suicidal ideation were diagnosed with a mood disorder, and 20% of people with suicidal ideation were diagnosed with a substance use disorder in the last 12 months (Kessler, Berglund et al., 2005). Among people who attempted suicide within the last 12 months, 70% were diagnosed with an anxiety disorder, 70% were diagnosed with a mood disorder, and 26% were diagnosed with a substance use disorder. Psychiatric diagnoses have been shown to increase the odds of lifetime and 12-month suicide attempts (Kessler et al., 1999; Kessler, Chiu, Demler, & Walters, 2005) (Table 2). Overall, it is evident that suicidal ideation and attempts occur across a wide range of psychopathology and that psychiatric disorders are risk factors for suicidal ideation and attempts.

People with one psychiatric diagnosis frequently meet criteria for one or more comorbid psychiatric diagnosis. Rates of comorbidity have been estimated as high as 72%, and comorbidity is largely attributed to Axis I disorders (56%) (Suominen, Henriksson, Suokas, & Isometsa, 1996). Comorbidity has been shown to increase risk for suicidal ideation and attempts. Several studies have shown a dose-response relationship between the number of comorbid disorders and odds of suicidal ideation, with a particularly dramatic increase in the risk of ideation among those with three or more disorders compared to fewer disorders (Kessler et al., 1999). Comorbidity has also been identified as a significant predictor over and above the effects of individual disorders among people who attempt suicide. Like ideation, the total number of comorbid disorders is related to the odds of a suicide attempt (Kessler et al., 1999). In particular, comorbid mood and substance use disorders increase the likelihood of attempted suicide (Beautrais, Joyce, Mulder, & Fergusson, 1996; Kessler et al., 1999; Moscicki, 1994). Especially lethal combinations occur when substance use disorders and personality disorders are comorbid with a mood disorder (Moscicki, 1997).

Taken together, the prevalence rates of mental illness among people with suicidal ideation and attempts, the odds of suicidal ideation and attempts given a specific psychiatric disorder, and the impact of comorbidity on suicide risk all suggest the need for a model of suicide that spans across psychiatric disorders. A transdiagnostic model of suicidal ideation and attempts will take into consideration contributions from each psychiatric disorder that may be predictive of suicidality. Looking at more than one diagnostic group has the advantages of identifying common risk factors and is essential in constructing a model of suicidal behavior (Mann, Wateraux, Haas, & Malone, 1999).

A Transdiagnostic Model

Across diagnoses, it is possible that elevated risk for suicide can be attributed to a few key constructs. Mann and colleagues (1999) proposed a model of suicide across diagnoses. They found that depression, hopelessness, and suicidal ideation were greater among suicide attempters and an impulsive-aggressive trait characterized individuals at risk for suicide attempt regardless of psychiatric diagnosis. In a recent review, Joiner and his colleagues (2005) identified two similar categories of risk for suicide. Citing both neurobiological and psychological evidence, they proposed that researchers should be examining the propensity for psychological pain, as seen in mood disorders, and dysregulated impulse control. There is substantial evidence that mood disorders are most often associated with suicidality, and major depression appears to account for the relationship to suicidality within affective disorders and as a comorbid disorder. Impulsivity, on the other hand, may explain the relationship between suicidality and both substance use disorders and cluster B personality disorders. Although there is preliminary evidence from psychological and neurobiological studies, these mechanisms are still poorly understood, and this model has yet to be tested empirically.

Both models present evidence for two underlying factors that may be predictive of suicide. This study will present evidence for three potential common factors across different diagnoses: negative mood similar to Joiner's "propensity for psychological pain" factor, impulsivity, and arousal. The negative mood factor is drawn from the literature on depression and suicidality. Depression alone has been consistently found to relate to suicidal ideation and attempts, and when it is comorbid with other disorders, often accounts for the relationship between those disorders and suicidality. Impulsivity

has been proposed as a mechanism that may explain the association between suicidal behavior and bipolar disorder, substance use disorders and personality disorders, such as borderline personality disorder and antisocial personality disorder (Joiner et al., 2005). In addition to depressed mood and impulsivity dimensions, this study proposes that there is a third variable related to suicidal behavior: arousal. Arousal may be driven by mixed states or anxiety disorders, in particular PTSD.

Beyond the addition of an arousal component this study is unique in that the three components of this model will be constructed using psychiatric symptoms instead of psychiatric diagnoses. Using psychiatric symptoms rather than clinical diagnoses has many advantages. Despite the fact that most disorders are related to elevated suicide risk, most people with a psychiatric disorder do not think about, attempt, or complete suicide (Moscicki, 1994). This may be in part due to the significant heterogeneity of symptom presentations. That is, two people who meet criteria for a given psychiatric diagnoses may experience different symptoms of that disorder. It is possible that a few key psychiatric symptoms are responsible for the elevated risk for suicidal ideation and attempts seen in people with psychiatric disorders. Clinical diagnoses also fail to capture a substantial portion of people who think about and attempt suicide who do not meet criteria for a psychiatric diagnosis, 20% and 12% respectively in the last 12 months (Kessler, Chiu et al., 2005). A possible explanation is that these people were experiencing subthreshold symptoms of one or more psychiatric disorders. This raises an interesting paradox: people with and without psychiatric diagnoses are engaging in suicidal behaviors. A symptom-based approach to determining common factors would capture

potential commonalities among people with and without psychiatric diagnoses who think about or attempt suicide.

In sum, a transdiagnostic model will examine common predictors of suicidal ideation and attempts across various psychiatric disorders, taking into account the elevated suicide risk in almost all disorders and the high rates of comorbidity among disorders. The predictors will be generated using a symptom-based approach. A symptom-based approach has the advantages of addressing different symptom profiles for the same disorder, avoiding the assessment of overlapping criteria from different diagnostic categories, and capturing people who fall below the threshold for clinical diagnosis (Widiger & Samuel, 2005).

The evidence reviewed below will span across psychiatric disorders to build support for the relationship of the three predictors of negative mood, impulsivity, and arousal with suicidality. In doing so, I will distinguish between risk factors involved in ideation and attempts. That is, I will review evidence that negative mood symptoms predict both ideation and attempts but that impulsivity and arousal specifically increase the risk of attempts once a person is experiencing ideation. To build evidence for negative mood, the relationship of major depressive disorder (as a pure diagnosis and as a comorbid condition) with both suicidal ideation and attempts will be examined. Then, two facets of the impulsivity literature will be described—links between impulsivity and suicide attempts, and impulsivity as a mediator of specific psychiatric disorders and suicide attempts. Then, the role of arousal, characterized by agitated or mixed depression and anxious arousal, in suicide attempts will be presented. One note is worth making, which is that because of the diagnostic specific nature of research, evidence for these

three dimensions will be reviewed across many studies to demonstrate that similar themes emerge repeatedly within each diagnostic category studied.

Negative mood

Researchers have emphasized depression and hopelessness as the major factors associated with suicide (Baumeister, 1990). Thus, support for a negative mood factor is derived from the relationship of major depressive disorder (MDD), major depressive episodes (MDE), and hopelessness with both suicidal ideation and attempts. The literature reviewed below will provide evidence for the strong relationship between MDD, hopelessness, and suicidal ideation and attempts and will also demonstrate how MDD as a comorbid disorder often accounts for the relationships of other psychiatric disorders with suicidal ideation and attempts.

Major depressive disorder. Major depressive disorder (MDD), the most common psychiatric disorder with lifetime prevalence estimates of 16%, shows the strongest associations with suicidal ideation and attempts (Kessler et al., 2005). This is not surprising given that the formal diagnostic criteria for MDD include presence of suicidality. Among people with suicidal ideation in the last 12 months, current MDD was the disorder most frequently diagnosed at a rate of 40% (Kessler et al., 2005). Having a diagnosis of MDD elevates risk for ideation. Specifically, people with a lifetime diagnosis of MDD were 10 times more likely to think about suicide in their lifetime (Kessler et al., 1999).

Beyond ideation, there is also ample evidence that MDD is related to suicide attempts. It has been estimated that 40% of suicide attempters meet diagnostic criteria for current MDD (Kessler et al., 2005) and people with MDD are at much greater risk for a

suicide attempt compared to people with no disorder (Kessler et al., 1999). The rates of suicide attempts among people with MDD are similar across ethnicities with the exception of Puerto Ricans who show elevated rates of suicide attempts (Oquendo et al., 2004). Overall, MDD is highly related to both suicidal ideation and attempts.

Major depressive episode. A major depressive episode (MDE) appears to account for some of the high rates of suicide observed among other affective disorders. Within bipolar disorder, depression is one of the driving forces for suicidality (Johnson, McMurrich, & Yates, 2005). Rates of suicide attempts are highest among those with bipolar II disorder (Dunner, Gershon, & Goodwin, 1976), most likely because a MDE is required for a diagnoses of bipolar II but not for bipolar I disorder. In sum, it appears that a MDE elevates risk for suicidal ideation and behavior in bipolar disorder.

Comorbidity with Major Depressive Disorder. MDD is frequently comorbid with other psychiatric diagnoses, including anxiety disorders, psychotic disorders, and alcohol and substance use disorders. When MDD is comorbid with other disorders, it appears to explain much of the elevation in suicidality observed within these disorders.

In clinical and epidemiological studies, anxiety disorders are positively associated with suicidal ideation and attempts, and there is a growing body of evidence that this association is due to comorbidity with other disorders, specifically major depression (Sareen, Cox et al., 2005). Panic disorder (PD) has received the most attention following results from initial epidemiological studies that suggested that people with PD were at greater risk for suicide attempts than people with other psychiatric disorders, with 20% of people with lifetime PD reporting suicide attempts (Weissman, Klerman, Markowitz, & Ouellette, 1989). Even though PD appeared to be so clearly been tied to suicidality,

much of this link appears to be explained by comorbid depression. Most notably, the risk for suicide attempts in uncomplicated PD has been estimated at 0% (Beck, Steer, Sanderson, & Skeie, 1991; Vickers & McNally, 2004) to 3% (Johnson, Weissman, & Klerman, 1990). Indeed, comparable findings regarding the role of depression in explaining the elevated rates of suicidal ideation and attempts in PD have been documented across sampling strategies, including community samples (Hornig & McNally, 1995; Johnson et al., 1990), outpatient clinical samples (Cox, Dorenfeld, Swinson, & Norton, 1994; Diaconu & Turecki, 2007; Lepine, Chignon, & Teherani, 1993; Mannuzza, Aronowitz, Chapman, & Klein, 1992; Rudd, Dahm, & Rajab, 1993; Warshaw, Massion, Peterson, & Pratt, 1995), and inpatient samples (Placidi et al., 2000). In sum, elevations in suicidality among people with PD appear to be explained by comorbid depression (Diaconu & Turecki, 2007).

Like PD, posttraumatic stress disorder (PTSD) is highly comorbid with MDD, and it has been documented that depression increases the risk of suicidal behavior within PTSD (Oquendo et al., 2005). Studies have shown that the two disorders interact to increase suicidal ideation and behavior (Freeman & Moore, 2000; Marshall et al., 2001; Oquendo et al., 2003). Research has also shown that affective disorders and borderline personality disorder (a personality disorder characterized by high levels of depressed mood) account for the relationship between PTSD and suicidality (Hornig & McNally, 1995; Oquendo et al., 2005; Yen et al., 2004). There is some literature to suggest that PTSD exerts direct effects on suicidality even when depression is not present (Sareen, Houlahan, Cox, & Asmundson, 2005; Sareen, Cox, Stein, Afifi, Fleet, & Asmundson,

2007). Taken together, there is some support for the role of comorbid MDD in the relationship between PTSD and suicidality.

Although not as extensive as the literatures on panic disorder and PTSD, there is growing evidence for role of depression in the relationship between suicidality and other anxiety disorders. In the NCS and its replication study (NCS-R), people with social phobia and simple phobia showed elevated rates of suicidal ideation and attempts, and persons with generalized anxiety disorder demonstrated modestly elevated rates of suicidality (Kessler et al., 2005). These disorders did not show significant associations with suicidal ideation or attempts after controlling for demographics and other disorders including mood disorders (Cox, Enns, & Clara, 2004; Sareen et al., 2005). Although more research on these disorders is needed, these preliminary results suggest that comorbid depression plays some role in the relationship between these disorders and suicidality.

Comorbid depression occurs in almost half of individuals with schizophrenia (Goh, Salmons, & Whittington, 1989), and as with the disorders above, depression is a risk factor for suicidality among patients with schizophrenia and schizoaffective disorder (Cohen, Lavelle, Rich, & Bromet, 1994; Goh et al., 1989; Harkavy-Friedman et al., 1999; Harkavy-Friedman, Nelson, Venarde, & Mann, 2004; Warman, Forman, Henriques, Brown, & Beck, 2004). Rates of concurrent depression have been estimated at 53-70% in suicide attempters with schizophrenia or schizoaffective disorder compared to 25-38% in non-attempters (Cohen, Leonard, Farberow, & Shneidman, 1964; Roy, 1982). Not only do patients with schizophrenia demonstrated clinically significant depressive symptoms immediately before a suicide attempt, but they also often describe depression as the

reason for the attempt (Altamura, Bassetti, Bignotti, Pioli, & Mundo, 2003; Harkavy-Friedman et al., 1999; Meltzer, Anand, & Alphas, 2000). In addition to concurrent depression, lifetime MDD in people with schizophrenia has been found to differentiate people with and without suicide attempts in both outpatient and inpatient settings (Altamura et al., 2003; Cohen et al., 1994; Gupta, Black, Arndt, Hubbard, & Andreasen, 1998). Overall, there are several studies that indicate a strong role of depression in explaining the relationship between suicidality and schizophrenia.

Depression has also been examined as a link between alcohol use disorders and suicidal ideation and attempts. Among people with treated or untreated alcohol use disorders, suicidal ideation was associated with higher rates of depression and mood disorders (Conner, Li, Meldrum, Duberstein, & Conwell, 2003; Driessen et al., 1998; McCloud, Barnaby, Omu, Drummond, & Aboud, 2004). Across both genders, suicidality increased among males and females with alcohol abuse or dependence for every additionally endorsed criterion of depression (Cottler, Campbell, Krishna, Cunningham-Williams, & Abdullah, 2005). Beyond ideation, MDD also increases risk for suicide attempts among those with alcohol use disorders (Biro, Selakovic-Bursic, & Kapamadzija, 1991; Roy, DeJong, Lamparski, & Adinoff, 1991). The presence of lifetime MDD appears to be more important than when the depression occurs. Depressive illness may pre-date alcohol abuse or can sometimes be identified as independent of the alcohol abuse; major depression prior to dependence, during abstinence, and during substance use predicted the occurrence of any suicide attempts among people in inpatient and outpatient treatment (Aharonovich, Liu, Nunes, & Hasin, 2002). It appears that the relationship with suicide attempts is stronger when the depression is independent of the

substance use disorder rather the result of the substance use disorder (Schuckit, Tipp, Bergman, & Reich, 1997). In sum, there is substantial evidence that MDD increases the risk for suicidal ideation and behavior among those with alcohol use disorders.

Similar to the pattern seen among people with alcohol use disorders, comorbid MDD plays a role in the relationship between illicit substance use and suicidality. Suicide has been identified as the leading cause of death among illicit drug users (Harris & Barraclough, 1997; Maloney, Degenhardt, Darke, Mattick, & Nelson, 2007). Many people with a substance use disorder who attempted suicide reported experiencing symptoms of comorbid depression including current depressed mood and hopelessness (Johnsson & Fridell, 1997).

Findings regarding depression appear to generalize when researchers study specific drugs of abuse. For example, a comorbid mood disorder has been shown to elevate the risk of suicide attempts among people who meet diagnostic criteria for marijuana abuse or dependence (Beautrais, Joyce, & Mulder, 1999). Among people with cocaine and opiate dependence, suicide attempters compared to non-attempters were more likely to have experienced lifetime episodes of MDD and to have received antidepressant treatment (Roy, 2001; Roy, 2002; Roy, 2003). MDD has also been cited as a risk factor for suicide attempt in heroin users, with a quarter to a third meeting criteria for lifetime major depression (Darke & Ross, 1997; Darke et al., 2007; Dinwiddie, Reich, & Cloninger, 1992). High levels of antidepressants present in drug overdose suicides by heroin users may be reflective of high rates of underlying depression (Darke & Ross, 2002). In sum, MDD appears to elevate the risk for suicidal ideation and attempts among people across different classes of substance use disorders.

Across anxiety disorders, psychotic disorders, and substance use disorders, there is ample evidence that comorbid MDD plays an important role in the relationships between other psychiatric disorders and suicidality. Beyond MDD, hopelessness has been found to be an important predictor of suicidal ideation and attempts, and should be included in the negative mood factor.

Hopelessness. Although not a diagnostic criterion of depression, hopelessness, defined as “negative expectations about the future,” (Beck, Weissman, Lester, & Trexler, 1974; p. 864) is frequently studied independently of diagnosis as a predictor of suicidality. Hopelessness has been shown to be predictive of ideation (Beck, Steer, Beck, & Newman, 1993; Petrie & Chamberlain, 1983; Steer, Kumar, & Beck, 1993), attempts (Beck, Kovacs, & Weissman, 1975; Dyer & Kreitman, 1984; Minkoff, Bergman, Beck, & Beck, 1973; Petrie & Chamberlain, 1983), and completed suicide (Beck, Steer, Kovacs, & Garrison, 1985; Beck, Brown, & Steer, 1989; Fawcett, Scheftner, Clark, & Hedeker, 1987; Kovacs, Beck, & Weissman, 1975).

Hopelessness appears to account for unique variance in suicidality after above and beyond depression. For example, several studies have shown that hopelessness was a significant predictor of suicidal ideation, after controlling for depression (Beck et al., 1993; Shahar, Bareket, Rudd, & Joiner, 2006), and after controlling for other known risk factors including demographics, age, and history of suicide attempts (Brezo, Paris, & Turecki, 2006). Hopelessness has demonstrated strong synchronous but not longitudinal associations with depression and suicidal ideation, suggesting that hopelessness, depression, and suicidal ideation may be part of a single syndrome (Beck et al., 1993; Shahar et al., 2006). Others have shown that hopelessness was a mediator of the

relationship between depression and suicidal ideation (Beck et al., 1975; Cole, 1988; Minkoff et al., 1973; Wetzel, Margulies, Davis, & Karam, 1980).

Among people who attempt suicide, hopelessness (see Brezo et al., 2006 for a review) may play a role at both the state and trait level as it is elevated before, during, and after episodes of depression (Mann et al., 1999). The stability of hopelessness during psychiatric treatment and after remission may be a greater a risk factor for suicide attempt than hopelessness itself (Dahlsgaard, Beck, & Brown, 1998; Young et al., 1996).

Hopelessness is also associated with suicidality in other disorders besides depression. In bipolar disorder, suicide risk was associated with expressed hopelessness among inpatient (Hawton, Sutton, Haw, Sinclair, & Harriss, 2005) and outpatient samples (Johnson et al., 2005). In people with psychosis, hopelessness has been found to be associated with suicide attempts (Beck et al., 1985; Drake & Cotton, 1986), and indeed, appeared more predictive than general depressive symptoms (Cohen et al., 1994; Drake, Gates, Whitaker, & Cotton, 1985). Among people with substance use disorders, hopelessness was risk factor for suicidal behavior even after controlling for major depressive or substance use disorder (Wen Hung, Gallo, & Eaton, 2004). Hopelessness may be one of the key symptoms of the negative mood factor that may be common across diagnostic categories.

In sum, MDD is highly associated with suicidal ideation and suicide attempts. In addition, MDE in other affective disorders, comorbid MDD, and hopelessness appear to play a strong role in the relationship between other psychiatric disorders and suicidal ideation. Taken together, symptoms of major depressive disorder and hopelessness will be selected for the negative mood factor. Theoretical, clinical, and epidemiological

studies suggest that depression or hopelessness, defined in this study as negative mood, can interact with impulsivity to increase risk for suicide (Swann, Steinberg, Lijffijt, & Moeller, 2008).

Impulsivity

Impulsivity has been defined as “a predisposition toward rapid, unplanned reactions to internal or external stimuli without regard to the negative consequences of these reactions to themselves or others” (Moeller, Barratt, Dougherty, Schmitz, & Swann, 2001; p. 1784). Studies estimate that approximately 50% of suicides and nonfatal violent attempts are considered impulsive (Simon et al., 2001). In fact, the urge to attempt suicide may be characterized as a fleeting feeling. Some evidence for this fleeting nature stems from anecdotal reports. For example, in Britain, there was a significant drop in suicide rates after the British government phased out coal gas in favor of natural gas in ovens. Because natural gas releases almost no carbon monoxide, kitchen ovens were no longer lethal tools for suicide. With removal of this widely accessible method, the possibility of death by “sticking one’s head in the oven” dropped, and accordingly, suicide rates dropped substantially (Anderson, 2008). Similar declines in suicide rates were seen in Northwest Washington after railings were raised on a notorious “suicide bridge.” Originally, this bridge had barriers that were waist-high, and was located within a mile of another bridge of equal height with barriers that were chest-high. People believed that if the barriers were raised on the “suicide bridge,” people would simply drive over to the other bridge. They were surprised to find that this was not the case. It appeared that if even a little more effort or time is required to think about suicide, the impulsive action is less likely to occur.

It has been hypothesized that a propensity for suicidal ideation and for impulsive behaviors may explain why people are prone to make attempts (Brezo et al., 2006; Mann et al., 1999). Impulsivity is a characteristic of people who attempt suicide and several psychiatric disorders including substance use, mania, borderline and antisocial personality disorders (Moeller et al., 2001). Trait impulsivity has been positively associated with attempt history across psychiatric disorders (see Brezo et al., 2006). Taken together, impulsivity may be an important link between psychiatric disorders and suicidal behavior. The literature reviewed below will examine impulsivity as a characteristic of suicide attempters, as a characteristic of psychiatric disorders, and as a potential explanation for relationships between specific psychiatric disorders and elevated risk for suicide attempts.

Impulsivity and suicide attempters. People with more impulsive traits have been found to be at greater risk of suicidal behavior (Horesh, Gothelf, Ofek, Weizman, & Apter, 1999; Plutchik & Van Praag, 1989). Impulsivity has been found to differentiate past attempters from those with no history of previous attempt and suicidal from non-suicidal inpatients with the same psychiatric diagnosis (Corruble, Damy, & Guelfi, 1999; Horesh et al., 1997). This link between impulsivity and suicidality appears to generalize across diverse psychiatric diagnoses (Brezo et al., 2006; Mann et al., 1999). As a characteristic of suicide attempters, impulsivity may help explain the relationship between suicidal behavior and psychiatric disorders such as substance use, mania, and personality disorders. The evidence reviewed below will demonstrate that substance use disorders, bipolar disorder, and borderline and antisocial personality disorders are

characterized by elevated impulsivity, and that impulsivity may explain the relationship of these disorders with suicide attempts.

Substance use disorders. Impulsivity is a correlate of substance use disorders (Moeller et al., 2001). Impulsivity in childhood, as defined by the presence of childhood impulse control disorders, is a risk factor for the development of substance abuse (Disney, Elkins, McGue, & Iacono, 1999; Young, Mikulich, Goodwin, & Hardy, 1995). Questionnaire and laboratory studies have found elevated impulsivity in substance-dependent people compared to healthy controls (Allen et al., 2005; Kirby, Petry, & Bickel, 1999; Madden, Petry, Badger, & Bickel, 1997; Moss, Yao, & Panzak, 1990; Patton, Stanford, & Barratt, 1995). People who use multiple substances appear to be more impulsive than those who are dependent on single substances (Logue, 1995).

When intoxicated with substances, people tend to experience short-term increases in impulsivity (Moeller et al., 2001). Impulsivity, however, remained elevated among substance-using participants after controlling for current substance use, suggesting that there is a trait component to impulsivity (Tcheremissine, Lane, Cherek, & Pietras, 2003). Taken together, evidence supports that impulsivity increases the risk for substance use-related disorders, and that during periods of intoxication, underlying problems of impulsivity are magnified.

It has been shown that comorbid substance use disorders elevate the risk for suicide attempt among people with anxiety disorders, psychotic disorders (Dervaux et al., 2001; Gut-Fayand et al., 2001), panic disorder (Friedman, Jones, Chernen, & Barlow, 1992; Friedman, Smith, & Fogel, 1999), bipolar disorder (Swann, Dougherty, Pazzaglia, Pham, & Moeller, 2004), and borderline personality disorder (Yen et al., 2004). That is,

in the context of other disorders, many that involve depressed mood, substance abuse disorders seem to increase the risk for suicidality and impulsivity may be a key ingredient (Dougherty, Mathias, Marsh, Moeller, & Swann, 2004; Putnins, 1995). Taken together, substance use disorders are characterized by impulsivity, and this may be an underlying mechanism that leads to elevated suicide risk in people with a primary or secondary substance use disorder.

Bipolar Disorder. The odds of attempting suicide are much greater among people with bipolar disorder than among those with unipolar depression (Kessler et al., 1999), suggesting that there is an additional and distinct mechanism that drives suicidality in addition to depressive symptoms. One candidate would be impulsivity.

Impulsivity is one of the symptoms listed in the diagnostic criteria for mania (Swann, Janicak et al., 2001). Elevations in impulsivity have been documented among patients with bipolar disorder using both questionnaires and laboratory paradigms. People with bipolar disorder compared to healthy controls demonstrated higher impulsivity, as measured by the Barratt Impulsiveness scale (BIS) across manic, depressed and euthymic mood states (Peluso et al., 2007; Swann, Anderson, Dougherty, & Moeller, 2001). Overall, impulsivity appears to be associated with bipolar disorder both between and during periods of manic symptoms.

Direct research on whether impulsivity relates to suicidality in bipolar disorder has yielded mixed results. In samples recruited by clinician referral or advertisements, Swann and colleagues (2004, 2005) found that people with bipolar disorder who had a history of suicide attempts were more impulsive on a laboratory task compared to those without a history of suicide attempts independent of mood state. Impulsivity levels were

correlated with the severity of suicide attempts. In contrast to these findings, impulsivity was not related to suicide attempt status within a sample of persons hospitalized with bipolar disorder (Michaelis et al., 2004; Oquendo et al., 2000). It is possible that already elevated levels of impulsivity intrinsic to the disorder may have obscured the relationship between impulsivity and suicide attempts within a more severely ill sample (Oquendo et al., 2000).

Borderline Personality Disorder (BPD). Personality disorders have been diagnosed in as many as 77% of suicide attempters (Suominen, Isometsa, Henriksson, Ostamo, & Lonnqvist, 2000). Comorbid MDD and BPD are associated with more suicidal behavior than MDD alone even with comparable severity of depression, suggesting that there is a mechanism involved in BPD that may be an additional risk factor for suicidal behavior above and beyond depressed mood (Malone, Haas, Sweeney, & Mann, 1995; Soloff, Lynch, & Kelly, 2002). As above, impulsivity is conceptualized as one mediator of the link between personality disorders and suicidality.

Impulsivity is a diagnostic criterion for BPD. Not surprisingly, BPD is associated with higher scores on trait and laboratory measures of impulsivity compared to scores observed among healthy or psychiatric controls (see Critchfield, Levy, & Clarkin, 2004; Dougherty, Bjork, Huckabee, Moeller, & Swann, 1999). Other evidence in support of the role of impulsivity in BPD comes from factor analysis and outcome studies. Factor analyses of symptoms have identified impulsivity as a distinct factor separate from identity disturbance and affective instability (Rusch, Guastello, & Mason, 1992). Impulsivity also consistently predicts outcome among people with BPD (Links, Heslegrave, & van Reekum, 1999). Several studies have found a relationship between

suicidality and impulsivity in patients BPD (Moeller et al., 2001). Within BPD, impulsivity is related to presence of at least one suicide attempt (Soloff, Lis, Kelly, Cornelius, & Ulrich, 1994), a higher number of previous suicide attempts, and a greater risk of future attempts even after controlling for the severity of the BPD symptoms (Brodsky, Malone, Ellis, Dulit, & Mann, 1997).

Antisocial Personality Disorder (ASPD). Although impulsivity is a criterion for the diagnosis of ASPD, not all people with ASPD manifest impulsive behaviors. Biological studies have shown, however, that those people with ASPD who do have a pattern of impulsive acts, in particular impulsive-aggressive acts, are distinct from those without a pattern of impulsivity (Moeller et al., 2001). Questionnaire and laboratory data across clinical and non-clinical samples provide substantial evidence for the role of impulsivity among some people diagnosed with ASPD.

There is limited research on the relationship between ASPD and suicidality. Suicide attempts and completions are serious problems in adult and juvenile offender populations and a handful of studies have identified ASPD and criminal behavior as predictors of suicide attempts (Alessi, McManus, Brickman, & Grapentine, 1984; Garvey & Spoden, 1980; Jenkins et al., 2005; Kempton & Forehand, 1992). Impulsivity appears to play a role in the relationship between ASPD and suicide attempts. The impulsive, antisocial behavioral features accounted for the relationship to suicidal indices, and the affective and interpersonal deficits (callousness, shallow affect, remorselessness) were unrelated or negatively related to suicidal behavior (Verona, Patrick, & Joiner, 2001; Verona, Hicks, & Patrick, 2005).

Taken together, substance use disorders, mania, borderline personality disorder and antisocial personality disorder are all characterized by high impulsivity. Impulsivity appears to explain some variance in the relationship between these disorders and suicidality. Overall, impulsivity is an important dimension that can be captured in by examining the symptoms of impulsivity outlined in the criteria of these disorders. Identifying key symptoms of impulsivity related to suicide attempts will be an important step in determining who is at risk for a suicide attempt.

Arousal

In addition to impulsivity, an arousal factor may be related to risk for suicide attempts. This may be characterized by arousal experienced during a mixed state or arousal due to anxiety, in particular PTSD. The literature reviewed below will examine the relationship between agitation and suicide attempts within mood and anxiety disorders.

Mixed states. Mixed states are defined by overlapping symptoms of depression and mania and encompass dysphoric mania, agitated depression, and mixed episodes. Agitated depression is a MDE with agitation symptoms (Koukopoulos & Koukopoulos, 1999; Maj, Pirozzi, Magliano, & Bartoli, 2003). Psychomotor agitation during a MDE has been reported in 20-35% of outpatients with mood disorders and as many as 70% of inpatients (Akiskal & Benazzi, 2005b; Schatzberg & DeBattista, 1999). Two related syndromes are defined within bipolar disorder. In mixed episodes, the criteria for both a major depressive episode and a manic episode are met nearly every day for a week. Dysphoric mania is defined by manic episodes with at least mild depressive symptoms, but depressive symptoms do not have to meet the full criteria for MDE. Given that mixed

episodes are relatively rare, much of the literature focuses on agitated and mixed depression.

Agitation is correlated with suicidality in cluster analyses of depression symptoms in clinical and community samples (Kendler, 1996; Korszun et al., 2004; Olgiati, Serretti, & Colombo, 2006; Sullivan, Kessler, & Kendler, 1998; Sullivan, Prescott, & Kendler, 2002). In a unipolar sample, psychomotor activation and racing thoughts during a major depressive episode predicted suicidal ideation (Akiskal, Benazzi, Berugi, & Rihmer, 2005). Studies have demonstrated that among suicide attempters with depression, most experienced agitation symptoms (Balazs et al., 2006).

Among people with bipolar I disorder, those with mixed depression, and specifically the symptoms of psychomotor agitation, racing thoughts, and flight of ideas during depression, showed elevated levels of suicidal ideation compared to those who do not experience these symptoms (Maj et al., 2003; Perugi, Akiskal, Micheli, Toni, & Madaro, 2001). Similarly, intra-episode hypomanic symptoms, specifically psychomotor agitation and racing thoughts, were significantly associated with suicidality in a sample of people with bipolar II disorder (Akiskal & Benazzi, 2005a). When the depression and mania overlap during a mixed episode, the risk for suicidal behavior tends to be the highest compared to depressed or hypomanic/manic episodes (Valtonen et al., 2007).

These findings are in concordance with growing support for a relationship between antidepressants and increased suicidality during the first two weeks, as antidepressant medications may trigger either an agitated depression or intra-episode hypomanic symptoms (Akiskal & Benazzi, 2005b). Taken together, there is compelling evidence for a component of arousal that is comprised in part of symptoms of hypomania

including psychomotor agitation, increased talkativeness, flight of ideas/racing thoughts, distractibility, decreased need for sleep, and irritability. These symptoms hypothetically should relate to a factor of arousal.

Anxious arousal. Symptoms of anxiety may also indicate an increase in arousal, in particular those associated with PTSD. These arousal symptoms may explain the independent association between PTSD and suicidality. Despite some debate, evidence supports an independent relationship between PTSD and suicide attempts in clinical and epidemiological studies (Oquendo et al., 2003; Oquendo et al., 2005; Sareen et al., 2005; Sareen, Houlahan et al., 2007). After controlling for major depression and other disorders, PTSD was predictive of both suicidal ideation and attempts (Marshall et al., 2001; Sareen, Houlahan et al., 2007). In a large epidemiological sample, PTSD was the only anxiety disorder independently associated with suicidal ideation and attempts, and the association remained strong after controlling for comorbid disorders (Sareen, Houlahan et al., 2005). This suggests that there may be another mechanism of PTSD above and beyond its overlap with depressed mood that is related to suicidality. One possibility is that the arousal symptoms associated with PTSD play a role in why this disorder maintains an independent association with suicidality above and beyond what is accounted for by a comorbid major depressive disorder. Specifically, symptoms such as difficulty sleeping, irritability or anger outbursts, difficulty concentrating, hypervigilance, and an exaggerated startle response, may explain the independent association between PTSD and suicidality.

Statement of Problem

Traditionally, researchers have studied predictors of suicide within a specific disorder. This disorder-specific approach has documented elevated rates of suicidality across psychiatric disorders and even more so for people with more than one disorder. The focus on suicidality within a series of specific disorders leads to a segmented approach that fails to consider risk factors that are common across disorders. This approach also does not address the subset of the population with no diagnosed psychiatric disorder that is also making suicide attempts.

The goal of this study is to move away from using diagnostic categories as predictors of suicidality and to test a model of three underlying common factors across disorders as predictors of suicidal ideation and attempts: negative mood, impulsivity, and arousal. Major theories have focused on the role of depression and impulsivity (Joiner et al., 2005; Mann et al., 1999). The diagnostic empirical literature is consistent with the idea that depressed mood, impulsivity, and arousal may each be involved. Nonetheless, it is important to acknowledge that there is relatively little direct empirical evidence to test this model across diagnoses. Indeed, it is the absence of literature that inspires this dissertation.

The factors were generated from symptoms of psychiatric diagnoses. Using symptoms has the advantage of capturing people who may have subthreshold diagnoses and teasing apart the noise in psychiatric diagnoses attributable to the heterogeneity of symptom presentations and comorbid diagnoses. The current study tested this novel approach in the National Comorbidity Survey-Replication study (NCS-R), a large-scale representative community sample of adults. The model may help clinicians and

researchers identify people at risk for suicidality more parsimoniously than a diagnostic assessment of each psychiatric disorder.

As a first step, I examined whether symptoms of DSM-IV disorders load onto three proposed factors: negative mood, impulsivity, and arousal. Symptoms were derived from the following diagnoses in the NCS-R dataset: depression, mania, irritable depression, dysthymia, panic disorder, generalized anxiety disorder, posttraumatic stress disorder, alcohol abuse/dependence, substance abuse/dependence, intermittent explosive disorder and symptoms from the personality disorders screener. These disorders were chosen because of their predictive power for suicidality, reviewed above. Symptoms were selected and categorized as negative mood, impulsivity, or arousal based on previous research and face validity (see Figure 1). For example, factor analyses of mania reveal a psychomotor acceleration factor consisting of racing thoughts, pressured speech and motor activity, suggesting that these variables would be likely to load on an arousal factor. The fit of the chosen symptoms with these three factors was empirically assessed using confirmatory factor analysis.

The second goal of this study was to determine if the three proposed factors were predictive of suicidal ideation and attempts. Drawing from previous research, it was hypothesized that negative mood would be highly associated with lifetime levels of suicidal ideation, and impulsivity and arousal would moderate the relationship between negative mood and suicide attempts. The model also assessed whether suicidal ideation mediated the relationship between negative mood and suicide attempts.

Hypotheses

Hypothesis 1. The first aim of the current study was to determine if psychiatric symptoms of key syndromes related to suicidality load onto three proposed factors: Negative Mood, Impulsivity, and Arousal. More specifically, it was expected that the following psychiatric symptoms would load onto each of the three factors (see Figure 1):

- 1) Negative mood: depressed/sad mood, anhedonia, lack of reactivity to pleasurable stimuli, low self-esteem, hopelessness, guilt, worry, feel empty inside.
- 2) Impulsivity: excessive involvement in pleasurable activities that have a high potential for painful consequences, substance taken in larger amounts or over longer period than intended, persistent desire or unsuccessful efforts to cut down or control use, continued use despite recurrent physical or psychological problems likely to be caused or exacerbated by the substance, recurrent use resulting in failure to fulfill major role obligations, using in situations in which it is physically hazardous, continued substance use despite persistent or recurrent social or interpersonal problems caused or exacerbated by the effects of the substance, several discrete episodes of failure to resist aggressive impulses that result in serious assaultive acts or destruction of property, give into urges.
- 3) Arousal: irritability/anger outbursts, insomnia or sleep disturbance, psychomotor agitation, increased talkativeness, flight of ideas, distractibility, panic attacks, feeling keyed up or on edge, hypervigilance, and exaggerated startle response.

Hypothesis 2. It was hypothesized that symptoms of Negative Mood would be related to suicidal ideation. Furthermore, because ideation tends to precede a suicide attempt, it was hypothesized that the relationship between Negative Mood and suicide attempts would be mediated by suicidal ideation (Figure 2).

Hypothesis 3. Impulsivity will moderate the relationship between negative mood and suicide attempts.

Hypothesis 4. Arousal will moderate the relationship between negative mood and suicide attempts.

Hypothesis 5. The fifth aim of this study was to determine how well negative mood, impulsivity, and arousal predict suicidal ideation and attempts (Figure 2).

Chapter 2: Method

Overview of National Comorbidity Survey Replication Methods (Kessler et al., 2004)

Data for this study were drawn from the National Comorbidity Survey Replication (NCS-R), a nationally representative mental health survey designed to assess prevalence and correlates of psychiatric disorders. The survey was approved by the Human Subjects Committees at Harvard Medical School and the University of Michigan. Consistent with the original study, consent was obtained verbally rather than written (Kessler, 1994). Interviews were conducted from February 2001 through December 2003 (Kessler & Merikangas, 2004). All respondents ($N = 9,282$) were administered the core diagnostic assessment (Part I). Those who met criteria for a disorder, met subthreshold lifetime criteria and sought treatment at some time in their life, or ever in their life made a plan to commit or attempt suicide were administered Part II of the interview. A probability sample of people who met subthreshold criteria for any Part I disorder, ever sought treatment for an emotional or substance problem, ever had suicidal ideation, or used any psychotropic medication was selected to receive Part II, as were an additional 25% of all other respondents. Part II included assessment of additional disorders and correlates. The total number of participants that received both Part I and Part II of the survey was 5,692. Participants were paid \$50 for completing the survey.

Interviewers

Field interviewers participated in two days of generalized training, followed by a seven day study specific training and were required to pass a NCS-R certification test. Interviewers were compensated using an hourly rate to discourage focusing solely on easy-to-recruit respondents.

Sample

Sample households were centrally selected and standardized methods were used to randomly recruit a member of the household. The sample was representative of non-institutionalized civilian adults ages 18 or older whose primary language was English. Selecting the sample involved four stages. In the first stage of sampling 62 primary representative sampling units (PSUs) were selected, each of which consisted of all counties in a metropolitan statistical area as defined by the US Census Bureau or individual counties. Sixteen of the 62 PSUs were ‘self-representing’ due to their size including: New York City, Los Angeles, Chicago, Philadelphia, Detroit, San Francisco, Washington DC, Dallas/Fort Worth, Houston, Boston, Nassau-Suffolk, NY, St. Louis, Pittsburgh, Baltimore, Minneapolis, and Atlanta. The three largest self-representing PSUs (New York, Los Angeles, and Chicago) were divided into 4 pseudo-PSUs and the remaining 13 PSUs were divided into two pseudo-PSUs. The other 46 PSUs were ‘non-self-representing,’ representative of smaller areas in the country. Thus there were a total of 84 PSUs and pseudo-PSUs, referred to going forward as PSUs.

In the second stage, each PSU was divided into segments of 50 to 100 housing units. A probability sample of 12 segments was chosen from non-self-representing PSUs. More segments were selected from the larger metropolitan areas. The final sample consisted of 1001 segments. Each segment was then visited by an interviewer who recorded all the housing units or updated the list generated during the baseline NCS. A random sample of housing units was then selected. Each housing unit had an equal chance of being selected. All residents in each housing unit were identified, and a probability procedure selected the household member that would serve as the respondent.

Students with a permanent home address were included in housing unit listings. The study achieved a response rate of 70.9% for complete interviews for a total of 9,282 respondents. These 9,282 interviews are treated as the achieved sample and exclude additional brief interviews that took place with respondents that refused to complete the full interview.

There are five weights that have been applied to the data. The locked building subsampling weight accounted for apartment buildings that were inaccessible. A within-household probability of selection weight adjusted for the probability that the selection of respondents in the housing units varied inversely with the number of people in the housing unit. A non-response adjustment weight adjusted for the fact that non-respondents differed from respondents. A post-stratification weight adjusted for the joint distribution of several socio-demographic variables, specifically age, sex, race-ethnicity, education, marital status, region, and urbanicity. An additional fifth weight accounted for the way Part II respondents were selected (see above). The joint product of all five weights was used to analyze the sample that completed Part II of the survey ($n = 5,692$).

The respondents that participated in Part II were of interest to this study. Respondents were 58% female, 74% Non-Hispanic White and 12% Non-Hispanic Black. Fifty-five percent of the sample was educated beyond 12 years of high school, 57% were married, and 60% were employed. The sample was fairly evenly distributed across age groups and regions of the country. Thirty-seven percent ($n = 2,107$) endorsed suicidal ideation at some point in their lifetime, and 8% ($n = 468$) endorsed making a suicide attempt. Sixty percent of people who attempted suicide endorsed making a single suicide attempt. The mean number of suicide attempts was 2.1 ($SD = 2.75$).

Measures

The Composite International Diagnostic Interview (CIDI), developed by the World Health Organization (WHO) is a fully structured interview designed for use in epidemiological and cross-cultural studies as well as clinics and research (Kessler & Ustun, 2004; Kessler, Abelson et al., 2004); www.hcp.med.harvard.edu/wmhcid). The CIDI is an expansion of the Diagnostic Interview Schedule (DIS). The WHO modified the CIDI for use in the NCS-R to include not only DSM criteria but also those of the International Classification of Disease (ICD) (Kessler & Ustun, 2004). The CIDI has been translated, field-tested, and used in epidemiological surveys in many different countries (Wittchen, 1994). The interview has been highly standardized to reduce variance due to questions asked, symptom information provided by respondents, time criteria to evaluate clinical relevance, and interpretation of information and diagnostic criteria (Wittchen, 1994).

The CIDI is designed to capture a broad range of information. It contains 22 diagnostic sections to assess mood, anxiety, substance use, and childhood disorders as well as impulse control disorders, psychoses, eating disorders, and to screen for personality disorders. The CIDI underwent significant modifications to gather more information regarding subthreshold psychopathology. Four separate sections assess suicidality (described below), 30-day functioning, 30-day psychological distress, and physical comorbidity. The CIDI also addresses the severity of mental disorders, burden, treatment and services. Length of administration is approximately 2 hours, but varied widely depending on the level of psychopathology an individual endorsed. Interviewers used a computer assisted version for administration.

The interview was administered in two parts. Part I contained core diagnostic assessments including major depressive disorder, dysthymia, bipolar I disorder, bipolar II disorder, panic disorder, specific phobia, agoraphobia, generalized anxiety disorder, social phobia, alcohol abuse/dependence, and intermittent explosive disorder. For those respondents who had no lifetime history of disorder, the interview was terminated after Part I. Respondent selection for Part II is noted above. Part II assessed for drug abuse/dependence, attention-deficit/hyperactivity disorder, oppositional defiant disorder, conduct disorder, separation anxiety disorder, nicotine dependence, posttraumatic stress disorder, obsessive-compulsive disorder, eating disorders, premenstrual dysphoria disorder, non-affective psychosis, pathological gambling, neurasthenia, and screened for personality disorders.

Suicidality was assessed by asking respondents if they have ever seriously thought about committing suicide, ever made a plan for committing suicide, or ever attempted suicide. They were also asked about the age of onset and the recency of the experience. Lethality was assessed in those who reported a suicide attempt in the last 12 months. Suicide attempts were classified by endorsing (1) I made a serious attempt to kill myself and it was only luck that I did not succeed or (2) I tried to kill myself, but I knew the method was not foolproof. Respondents who endorsed that their attempt was a cry for help and they did not want to die were considered to have made a suicide gesture (Borges et al., 2006). Past attempts were not assessed for self-reported intent to die.

Version 3.0 of the CIDI was used in the NCS-R study. A clinical reappraisal study was conducted on the CIDI 3.0 (Haro et al., 2006). A probability subsample of 325 respondents was chosen, oversampling respondents who met lifetime criteria for DSM-IV

disorders. The respondents were interviewed over the phone using the Structured Clinical Interview for DSM-IV (SCID-IV; First, Spitzer, Williams, & Gibbon, 1997). SCID interviewers were unblinded to the diagnostic stem questions endorsed on the CIDI 3.0 to account for respondent inconsistency across time and a documented tendency to endorse fewer stem questions in follow-up interviewers (Kessler et al., 1998). Comparisons were made for panic disorder, phobias, PTSD, major depression, bipolar disorder, and alcohol or drug abuse with or without dependence. Differences in lifetime prevalence were significantly higher for the SCID-IV for all disorders with the exception of panic disorder, specific phobia, bipolar I and II disorders. Concordance for lifetime prevalence diagnoses were moderate (AUC ranging from 0.7 to 0.8) for panic disorder, any phobia, any anxiety disorder, major depression, alcohol dependence, drug abuse, and any disorder, substantial for alcohol abuse and agoraphobia (AUC ranging from 0.8-0.9), high (AUC greater than or equal to 0.9) for bipolar disorder, and fair for specific phobia, social phobia, PTSD, and drug dependence (AUC ranging from 0.6-0.7). Most CIDI 3.0 cases were confirmed by the SCID. The authors of the study concluded that CIDI 3.0 diagnostic thresholds for lifetime prevalence of DSM-IV disorders were more conservative compared to the SCID (Haro et al., 2006). Overall, the CIDI appears to be a reliable tool for determining the frequency of symptoms and distributions of mental disorders.

Overview of Statistical Analyses

All analyses were completed using Mplus version 4.2 (Muthén & Muthén, 1998-2007) and SPSS version 16.0. Before conducting analyses of hypotheses, frequency distributions for all categorical variables were examined. Analyses proceeded in four

steps and were conducted taking into account the sampling design of the study. First, using factor analysis techniques, each hypothesized factor was tested individually to see if a one-factor solution best fit the data. Rejection of a single factor model suggests that a more complex model might better fit the data. Next, a confirmatory factor analysis was conducted for all factors to determine their relationship to one another. Then, structural equation modeling was used to examine the factors as predictors of suicidal ideation and suicide attempts. Where possible, the factors were then compared to traditional predictors of suicide attempts to determine whether they were stronger predictors. Finally, moderation of negative mood in the prediction of suicide attempts was examined using logistic regression in SPSS.

Model fit was determined using the following four tests: the χ^2 test of model fit (cut off = $p < .05$), the Weighted Root Mean Square Residual (WRMR; cut off < 1.0), the Root Mean Square Error of Approximation (RMSEA; cut off < .06), and the Bentler Comparative Fit Index (CFI; cut off > .95; Bollen, 1989; Muthén & Muthén, 1998-2007). The χ^2 test of model fit is a test of the hypothesis that the model has perfect fit in the population. Failure to reject the null hypothesis provides support for the model (Kline, 2005). When sample sizes are large, such as in the case of this sample, the value of the χ^2 might incorrectly lead to rejection of the model. To decrease the sensitivity to a large sample size, researchers will divide the value of the χ^2 by the degrees of freedom with values between 2.0 and 3.0 indicating reasonable fit (Kline, 2005). The Weighted Root Mean Square Residual is employed when data is categorical and is an adjusted difference between observed and predicted covariances (Finney & DiStefano, 2006). The Root Mean Square Error of Approximation (RMSEA) approximates a non-central chi-square

square distribution, and assumes that fit of the model in the population is not perfect. Higher RMSEA values indicate worse model fit (Kline, 2005). The Comparative Fit Index assesses the proposed model against a baseline or null model in which the population covariances of observed variables are zero (Kline, 2005). These indexes reflect the current recommendations about what to report in written summaries of analyses (Kline, 2005).

When conducting confirmatory modeling, it is often necessary to make modifications to the hypothesized model. To avoid spurious relationships that are unique to a given sample, these modifications should be kept to a minimum and should be theoretically justifiable. Modifications to the model were made if they significantly improved model fit. Improvement was defined as a change in χ^2 of 3.84 per degree of freedom (i.e., $p < .05$) (Kline, 2005). When items were removed from a factor because of weak loadings, analyses were conducted to see whether they cohered into a separate factor. If no separate factor was identified or if the identified factor was not a predictor in subsequent models, the indicators were removed from the model.

Missing Data

All participants were asked the CIDI screening questions. The screening questions serve as entry criteria into diagnostic modules for depression, mania, irritable depression, generalized anxiety disorder, substance use disorders, specific phobia, social phobia, and agoraphobia. The structure of the CIDI is such that when a participant responds 'no' to a screening question, the subsequent questions regarding that diagnosis are not asked. Thus, there is a significant amount of systematically missing data. The large amounts of missing data make it difficult to implement the proposed model using individual items as

indicators. Several steps were taken to address the missing data. When available, screener questions were included in statistical models, as these were asked of all participants and unlikely to have substantial amounts of missing data. For other items, such as sad or depressed mood, composite variables were created that summarized across all variables in the dataset that covered depressed mood. For these summaries, a person was coded as having a symptom variable if they positively endorsed any of the relevant items in the dataset (see Table 3). Such multiple items were available to assess *panic attacks, psychomotor activation, irritability, insomnia, racing thoughts, talkativeness, distractibility, feeling keyed up or on edge, sad mood, anhedonia, worry, low self-esteem, feeling worthless or guilty, excessive involvement in pleasurable activities that have a high potential for painful consequences, substance taken in larger amounts or over longer period than intended, persistent desire or unsuccessful efforts to cut down or control use, continued use despite recurrent physical or psychological problems likely to be caused or exacerbated by the substance, recurrent use resulting in failure to fulfill major role obligations, using in situations in which it is physically hazardous, continued substance use despite persistent or recurrent social or interpersonal problems caused or exacerbated by the effects of the substance, and give into urges*. For the alcohol use section, if participants did not endorse alcohol use that caused social, occupational, or functional impairment, and drank less than an average of 4 drinks during their period of heaviest drinking, the subsequent symptom questions regarding alcohol and substance use problems were coded as 0, rather than as missing data, as it is highly unlikely that participants would endorse other symptoms of alcohol or substance abuse or dependence. Composite variables and missing data are summarized in Table 3.

Analyses were conducted using full information maximum likelihood (FIML), as implemented in Mplus. In FIML, parameters and standard errors are estimated using all available data assuming data are missing at random (MAR) (Enders, 2006). This assumption implies missingness may be predicted from other variables available for analysis. Cases are included, then, even if data is missing for a given variable. The sample size for all analyses was 5,692.

Chapter 3: Results

Negative Mood Confirmatory Factor Analysis

The proposed indicators of a Negative Mood factor included the following symptoms: *sad mood*, *anhedonia*, *worry*, *hopelessness*, *low self-esteem*, *worthless/guilt*, and *emptiness*. A one-factor solution was tested and did not fit the data. Results also revealed that the *sad mood* variable demonstrated a linear dependency with *low self-esteem*, *worthlessness/guilt*, and *hopelessness*. *Sad mood* was thus removed from the analyses, given its linear relationship with several other indicators. A confirmatory factor analysis was conducted with the following symptoms as indicators: *anhedonia*, *worry*, *hopelessness*, *low self-esteem*, *worthless/guilt*, and *emptiness*. This model did not provide a good fit for the data ($\chi^2(6) = 462.706, p < .01$; CFI = .75, RMSEA = .12, WRMR = 5.34). Results suggested that little variance in the symptoms of *low self-esteem*, *worthlessness/guilt*, and *hopelessness* was being explained by the current factor. The model was modified to include two latent variables: a Negative Mood latent variable with *anhedonia*, *worry*, and *emptiness* as indicators and a Negative Thinking variable with *low self-esteem*, *worthlessness/guilt*, and *hopelessness* as indicators. Model fit improved significantly ($\chi^2(5) = 39.71, p < .01$; CFI = .98, RMSEA = .04, WRMR = 1.57). The latent variables were significantly correlated ($r = .20$). Modification indices suggested improvement in model fit could be obtained by loading *emptiness* and *anhedonia* onto both the Negative Mood and Negative Thinking latent variables. *Anhedonia* demonstrated a negative relationship with Negative Thinking and maintained a strong positive association with the Negative Mood. This model demonstrated excellent fit (χ^2

(5) = 3.69, $p = .59$; CFI = 1.00, RMSEA = .00, WRMR = .38). The final model for Negative Mood and Negative Thinking is shown in Figure 4.

Impulsivity Confirmatory Factor Analysis

The proposed indicators of the Impulsivity factor were the following symptoms: *excessive involvement in pleasurable activities that have a high potential for painful consequences, substance taken in larger amounts or over longer period than intended, persistent desire or unsuccessful efforts to cut down or control use, continued alcohol or substance use despite recurrent physical or psychological problems likely to be caused or exacerbated by the substance, recurrent alcohol or substance use resulting in failure to fulfill major role obligations, using alcohol or substances in situations in which it is physically hazardous, continued substance use despite persistent or recurrent social or interpersonal problems caused or exacerbated by the effects of the substance, several discrete episodes of failure to resist aggressive impulses that result in serious assaultive acts or destruction of property, and gives into urges*. The model did not fit the data ($\chi^2 (8) = 125.04, p < .01$; CFI = .99, RMSEA = .05, WRMR = 2.13), although the CFI and RMSEA indices were acceptable. Little of the variance in *excessive involvement in pleasurable activities that have a high potential for painful consequences* ($R^2 = .34$), *several discrete episodes of failing to resist aggressive impulses that result in serious assaultive acts or destruction of property* ($R^2 = .27$), *gives into urges* ($R^2 = .45$), and *substance taken in larger amounts or over longer period than intended* ($R^2 = .61$) was explained by the impulsivity factor. Removing these indicators from the model resulted in adequate model fit ($\chi^2 (4) = 19.01, p = .0008$; CFI = 1.00, RMSEA = .03, WRMR = 1.05). An examination of the residuals revealed that a large residual covariance between

persistent desire or unsuccessful efforts to cut down or control use and continued alcohol or substance use despite recurrent physical or psychological problems likely to be caused or exacerbated by the substance. The errors of these indicators were correlated, and this resulted in excellent model fit ($\chi^2 (3) = 8.62, p = .03$; CFI = 1.00, RMSEA = .02, WRMR = .69). The final factor, renamed Recurrent Substance Use, is depicted in Figure 5. The symptoms that were systematically removed from the model did not cohere into a separate factor.

Arousal Confirmatory Factor Analysis

The proposed indicators of Arousal included the following symptoms: *panic attack, psychomotor activation, irritability or anger, insomnia, racing thoughts, talkative, distractible, feeling keyed up or on edge, hypervigilant, and exaggerated startle response.* Three indicators (*keyed up, hypervigilant, and exaggerated startle response*) had to be removed from the analyses as they did not meet the minimum covariance coverage requirement in Mplus (10%) due to the amount of missing data (Table 3). Confirmatory factor analyses using the remaining indicators revealed that the model did not fit the data ($\chi^2 (8) = 167.79, p < .01$; CFI = .87, RMSEA = .06, WRMR = 3.20). Little of the variance in the *talkativeness* ($R^2 = .008$), *insomnia* ($R^2 = .03$), and *distractible* ($R^2 = .08$) indicators was explained by the Arousal factor. Removing these indicators one at a time respectively from the model resulted in good model fit ($\chi^2 (2) = 2.13, p = .34$; CFI = 1.00, RMSEA = .003, WRMR = 0.43). The remaining model (*panic attacks, psychomotor activation, irritability/anger, and racing thoughts*) was renamed Negative Emotional Arousal. The indicators that were removed (*talkativeness, insomnia, and distractible*) did cohere into a separate factor (Non-Emotional Arousal), and the model fit the data. This

separate factor was highly correlated with the Negative Emotional Arousal factor and did not predict any outcomes in subsequent structural equation modeling. Thus it was decided to maintain the Negative Emotional Arousal factor with *panic attack*, *psychomotor activation*, *irritability or anger*, and *racing thoughts*, as indicators (Figure 6).

Combined Model

The four factors of Negative Mood, Negative Thinking, Recurrent Substance Use, and Negative Emotional Arousal were then tested simultaneously. This model did not fit the data ($\chi^2 (14) = 75.34, p < .01$; CFI = .99, RMSEA = .03, WRMR = 1.54). Negative Mood was highly correlated with Negative Emotional Arousal ($r = .94$). A nested model was tested constraining the covariance between the two factors. The difference between the two models was not significant ($\chi^2 (1) = .004, p = .95$). The lack of difference indicates that the more constrained model was not different from the less constrained model and that Negative Mood and Negative Emotional Arousal should be combined into a single factor in order to make the model more parsimonious.

Because of the overlap between Negative Mood and Negative Emotional Arousal, the coherence of depressive items was reconsidered including arousal items. A single solution factor analysis was conducted with all of the original Negative Mood indicators and the Negative Emotional Arousal indicators. This model did not fit the data ($\chi^2 (12) = 298.10, p < .01$; CFI = .91, RMSEA = .07, WRMR = 3.68), and explained little variance in the symptoms of *low self-esteem*, *worthlessness/guilt*, *hopelessness*, and *racing thoughts*. These variables were removed and a Negative Thinking factor was recreated, along with a Negative Mood/Emotional Arousal factor. The model fit indices

demonstrated an improvement in model fit, ($\chi^2 (12) = 97.51, p < .01$; CFI = .97, RMSEA = .04, WRMR = 2.03). The CFI and RMSEA indices were adequate. Negative Mood/Emotional Arousal and Negative Thinking were correlated at $r = .29$. Modification indices [at each step] suggested that substantial decreases in chi-square could be achieved by loading *anhedonia*, *racing thoughts*, and *emptiness* onto Negative Mood/Emotional Arousal and Negative Thinking variables. Modification indices also suggested residual covariances remained substantial for *psychomotor activation* with *low self-esteem*, *irritable or angry* with *psychomotor activation*, and *racing thoughts* with *anhedonia*. Correlating errors between these indicators resulted in excellent model fit ($\chi^2 (11) = 22.98, p = .02$; CFI = .99, RMSEA = .01, WRMR = .91). The final Negative Mood/Emotional Arousal and Negative Thinking factors are illustrated in Figure 7.

Recurrent Substance Use was then incorporated into the model. The model did not fit the data, although the CFI and RMSEA indices were adequate ($\chi^2 (14) = 56.94, p < .01$; CFI = .99, RMSEA = .02, WRMR = 1.33). Modification indices suggested that a significant improvement in chi-square could be obtained by loading *worry* on Recurrent Substance Use and *continued use despite recurrent physical or psychological problems* onto Negative Mood/Emotional Arousal. Fit indices improved and were adequate ($\chi^2 (13) = 30.59, p = .004$; CFI = .99, RMSEA = .02, WRMR = .99). The final CFA model is illustrated in Figure 8.

Structural Equation Modeling

It was initially hypothesized that Negative Mood would predict suicidal ideation; Bivariate and partial correlations of factor scores with Suicidal Ideation were examined prior to structural equation modeling. Bivariate correlations demonstrated significant

relationships of Suicidal Ideation with Negative Mood/Emotional Arousal ($r = .45, p < .001$) and with Negative Thinking ($r = .19, p < .001$). Negative Mood/Emotional Arousal remained significantly associated with Suicidal Ideation, after controlling for Negative Thinking ($r = .43, p < .001$). After controlling for Negative Mood/Emotional Arousal, Negative Thinking and Suicidal Ideation were no longer strongly related ($r = -.03, p = .02$) (Table 4).

Using structural equation modeling techniques, Suicidal Ideation was regressed on both Negative Mood/Emotional Arousal and Negative Thinking. The initial model did not fit the data ($\chi^2 (12) = 40.05, p = .0001$; CFI = .99, RMSEA = .02, WRMR = 1.15). Modifications were made to the model that included correlating the errors of *irritable* with *worthlessness/guilt*, *racing thoughts* with *PMA*, and *ideation* with *low self-esteem*. This resulted in an improvement in model fit and adequate fit indices ($\chi^2 (11) = 26.07, p = .006$; CFI = .99, RMSEA = .02, WRMR = .92). Negative Mood/Emotional Arousal was a strong positive predictor of Suicidal Ideation controlling for Negative Thinking ($\beta = .79, z = 38.26, p < .01$). Negative Thinking was not a significant predictor of Suicidal Ideation after controlling for Negative Mood/Emotional Arousal ($\beta = -.03, z = -1.15, p > .01$) (see Figure 9).

Correlations of Suicide Attempts with Negative Mood/Emotional Arousal and Negative Thinking were conducted. Suicide Attempts were significantly correlated with Negative Mood/Emotional Arousal ($r = .24, p < .001$) and with Negative Thinking ($r = .23, p < .001$). Negative Mood/Emotional Arousal remained significantly associated with Suicide Attempts, after controlling for Negative Thinking ($r = .16, p < .001$). After controlling for Negative Mood/Emotional Arousal, Negative Thinking and Suicide

Attempts were also significantly correlated ($r = .13, p < .001$) (Table 4). Next, the steps outlined by Baron and Kenny (Baron & Kenny, 1986) were followed to test whether Suicidal Ideation mediated the relationship between Negative Mood/Emotional Arousal and Suicide Attempts, controlling for Negative Thinking. Analyses proceeded in two additional steps. First, Suicide Attempts was regressed on Negative Mood/Emotional Arousal and Negative Thinking. The total effects of Negative Mood/Emotional Arousal and Negative Thinking on Suicide Attempts without Suicidal Ideation in the model were both significant ($\beta_{\text{Negative Mood}} = .51, z = 16.16, p < .01; \beta_{\text{Negative Thinking}} = .32, z = 7.04, p < .01$) (Figure 10). Model fit was excellent ($\chi^2(11) = 18.99, p = .06; CFI = .99, RMSEA = .01, WRMR = .82$).

In the second step, Suicide Attempts was regressed on Suicidal Ideation, Negative Mood/Emotional Arousal, and Negative Thinking. Model fit was excellent ($\chi^2(12) = 25.96, p = .01; CFI = .99, RMSEA = .02, WRMR = .89$). Suicide Attempts was positively predicted by Suicidal Ideation ($\beta = .53, z = 2.34, p < .01$) and Negative Thinking ($\beta = .36, z = 8.48, p < .01$). Negative Mood/Emotional Arousal remained a significant predictor of Suicidal Ideation ($\beta = .79, z = 37.73, p < .01$) and did not have a direct effect on Suicide Attempts ($\beta = .08, z = .44, p > .05$) (see Figure 11). That is, Negative Mood/Emotional Arousal exhibited an indirect effect on Suicide Attempts via Suicidal Ideation ($\beta = .42, z = 2.34, p < .05$), controlling for Negative Thinking. These results suggest that Suicidal Ideation mediates the relationship between Negative Mood/Emotional Arousal and Suicide Attempts and that Negative Thinking has a direct effect on Suicide Attempts.

Bivariate and partial correlations of Recurrent Substance Use with Suicidal Ideation and Suicide Attempts are displayed in Table 4. Recurrent Substance Use was

then included in the structural model prior to examining its moderating effects. This model is illustrated in Figure 12. Fit indices for the final model were adequate ($\chi^2(15) = 41.32, p = .0003$; CFI = .99, RMSEA = .02, WRMR = 1.03). When Recurrent Substance Use was included in the model, Negative Mood/Emotional Arousal remained a significant predictor of Suicidal Ideation ($\beta = .79, z = 26.72, p < .01$). Negative Thinking and Recurrent Substance Use did not predict Suicidal Ideation ($\beta = -.04, z = -1.44, p > .05$; $\beta = .009, z = .28, p > .05$). Negative Thinking ($\beta = .34, z = 7.71, p < .01$), Recurrent Substance Use ($\beta = .12, z = 2.68, p < .01$), and Suicidal Ideation ($\beta = .50, z = 2.21, p < .01$) were positive predictors of Suicide Attempts, all controlling for other variables in the model. Negative Mood/Emotional Arousal did not significantly predict Suicide Attempts ($\beta = .05, z = .28, p > .05$). Negative Mood/Emotional Arousal was significantly correlated with Negative Thinking ($r = .29$) and Recurrent Substance Use ($r = .55$), and Recurrent Substance Use was significantly correlated with Negative Thinking ($r = .20$).

The same model was examined using number of suicide attempts as a continuous outcome. The mean number of suicide attempts was 2.09 ($SD = 2.75$). This variable was also highly skewed ($skew = 4.98, SE = .11$) and leptokurtic ($kurtosis = 29.38, SE = .23$). The model did not fit the data ($\chi^2(15) = 118.76, p < .001$; CFI = .99, RMSEA = .04, WRMR = 1.77).

Comparison of Negative Thinking with Hopelessness

Correlation analyses were conducted to compare hopelessness, a traditionally studied predictor of suicide attempts, to the Negative Thinking factor identified in this study. The correlation between the hopelessness indicator and suicide attempts (Spearman's $\rho = .19$) was compared to the correlation between the Negative Thinking

factor score and suicide attempts ($r = .23$) (Cohen & Cohen, 1983). The difference between these correlations was significant ($p = .05$), suggesting a stronger relationship between the factor and suicide attempts than between hopelessness alone and suicide attempts.

Moderation Analyses

To examine whether Recurrent Substance Use moderated the relationships of Negative Mood/Emotional Arousal and Negative Thinking with Suicide Attempts, parallel logistic regression analyses were conducted. Logistic regression analyses were conducted in SPSS because Mplus could not support the moderation analyses within a complex sample design. Factor scores of Negative Mood/Emotional Arousal, Negative Thinking, and Recurrent Substance Use were centered. In the first analysis, the dependent variable, Suicide Attempts, was regressed on Negative Mood/Emotional Arousal, Recurrent Substance Use, and the interaction between the Negative Mood/Emotional Arousal and Recurrent Substance Use. Negative Mood/Emotional Arousal and Recurrent Substance Use were both significantly related to Suicide Attempts ($\beta_{\text{Negative Mood/Emotional Arousal}} = 1.04$, Wald (1) = 96.87, $p < .001$; $\beta_{\text{Impulsivity}} = .26$, Wald = 4.94, $p = .03$). The interaction term was significant ($\beta = .23$, Wald (1) = 5.08, $p = .02$). Post-hoc analyses examined the relationship between Negative Mood/Emotional Arousal and Suicide Attempts at mean levels of Recurrent Substance Use, and at one standard deviation above and below the mean of Recurrent Substance Use. Results are shown in Table 5. For every one standard deviation increase in Negative Mood/Emotional Arousal, people who are high on Recurrent Substance Use have higher odds of making a suicide attempt (OR = 3.30) compared to people with mean (OR = 2.84) or low levels (OR = 2.4) of Recurrent

Substance Use. Taken together, Negative Mood/Emotional Arousal is a stronger predictor of Suicide Attempts among people with high levels of Recurrent Substance Use.

A parallel model was examined for Negative Thinking. The dependent variable, Suicide Attempts, was regressed on Negative Thinking, Recurrent Substance Use and their interaction. The main effects of Negative Thinking and Recurrent Substance Use were both significant ($\beta_{\text{Negative Thinking}} = 1.32$, Wald (1) = 85.13, $p < .001$; $\beta_{\text{Recurrent Substance Use}} = .64$, Wald (1) = 52.49, $p < .001$). The interaction term did not significantly predict Suicide Attempts ($\beta = .35$, Wald (1) = 2.09, $p = .15$). No further analyses were conducted. Taken together these results demonstrate that Recurrent Substance Use moderates the relationship between Negative Mood/Emotional Arousal and Suicide Attempts, and does not moderate the relationship between Negative Thinking and Suicide Attempts.

Chapter 4: Discussion

The goal of this study was to understand key symptoms that predicted suicidal ideation and suicide attempts. This study was unique in taking a transdiagnostic approach to this issue. That is, potential predictors were not defined by specific psychiatric diagnoses, but rather, by psychiatric symptoms to understand the driving forces for suicide attempts across a wide spectrum of psychiatric disorders. Whereas other people have examined suicidality within epidemiological samples, they tend to focus on the predictive value of diagnostic status (Kessler et al., 1999; Kessler et al., 2005). Those studies have found that almost all disorders elevate suicide risk, that psychiatric comorbidity increases that risk, and that there is a substantial amount of people without psychiatric diagnoses that make suicide attempts. A significant goal of this study is to look at symptom dimensions that may be common across people with multiple psychiatric diagnoses as well as among people without psychiatric diagnoses. The theoretical model was derived from symptoms, which addresses the possibility that different symptom profiles for the same disorder might relate differentially to suicidality and accounts for overlapping symptoms from different diagnostic categories. A second important goal of this study was to use a dimensional approach to include those individuals in the NCS-R sample who did not meet criteria for a psychiatric diagnosis but did make a suicide attempt. Using a symptom-based approach with epidemiological data allows for predictors of suicide attempts to generalize beyond psychiatric diagnoses and to be applied to the general population.

More specifically, psychiatric symptoms were tested as indicators of latent variables using factor analyses. Three factors (Negative Mood, Impulsivity, and Arousal)

were conceptualized based on previous research on suicide conducted within specific diagnostic domains (Hypothesis 1). Negative Mood was hypothesized to predict Suicidal Ideation, and Suicidal Ideation was hypothesized to mediate the relationship between Negative Mood and Suicide Attempts (Hypothesis 2). Impulsivity and Arousal were hypothesized to moderate the relationship between Negative Mood and Suicide Attempts (Hypotheses 3 and 4).

Before examining the results, I will address the limitations and strengths of this study. Against that backdrop, I will discuss the symptom dimensions that were identified. Next, I will focus on a model of how these latent variables correlated with suicidal ideation and attempts. Finally, I will explore how these findings relate to and expand upon the current suicidality literature, and I will propose directions for future research.

Limitations

Several limitations must be noted related to the design of the NCS-R study which served as the source of data for this investigation. The final study sample was influenced by an imperfect response rate and the exclusion of people who completed suicide, influencing external validity and generalizability. In considering this methodology it is important to note as is typical in epidemiological studies, the original goal was to identify representative households and to recruit a participant from each of those households. Although the investigators achieved a remarkable 70.9% response rate, a certain level of inference is involved in considering the effects of those 29.1% that could not be reached to be enrolled in the study (Kessler et al., 2004). Every attempt has been made to control for this issue through the inclusion of five different weights. As noted above, the data were weighted to account for inaccessible addresses, the selection of respondents within a

housing unit, study refusals, sociodemographic variables, and presence of mental health issues indicated by enrollment in Part II of the study. In the end, we do not really know if people in those households that did not participate were more psychiatrically ill or more suicidal. We are assuming that the relationships found here would generalize to those people who were not enrolled. The exclusion of people who committed suicide also does not allow us to draw conclusions about people who complete suicide (Nock & Kessler, 2006).

Another issue of study design is the cross-sectional nature of the NCS-R data, which limits interpretability. It is difficult to know temporally when psychiatric symptoms and suicide attempts occur. It is possible that symptoms of negative mood and negative thoughts arise in the aftermath of a failed suicide attempt.

The requirement for participants to self-report on psychiatric symptoms and suicidality may have introduced biases into the data. The NCS-R relied on retrospective self-report. The current mood state and symptoms of participants might induce biases in the recall of symptoms (Nock & Kessler, 2006). In addition, suicide-related behaviors are likely to be underreported because of stigma, and stigma may vary across sociodemographic groups (Kessler, Berglund et al., 2005).

Another limitation of this study is the structure of the sole instrument used to gather data in this study. The CIDI relies extensively on screening questions, which has two important implications. The first is that this structure resulted in systematically missing data for many of the symptoms in the model (Table 3). Mplus uses a special maximum likelihood estimation method for datasets in which some observations are missing at random, as they are in this case. For most variables, however, missing data

could be significantly minimized by creating composite variables of similar symptoms queried within different modules. Nonetheless, three items that had to be removed from the analyses, specifically from the Arousal latent variable, because too few people endorsed screening questions for PTSD and responded to questions about those symptoms. Second, the structure of the CIDI interview also influenced the nature of what was testable. In an ideal study, all symptom questions would be asked of all participants; however, this is almost never done in studies that rely on diagnostic interviews due to the sheer number of symptoms to be covered. To deal with methodological weaknesses, the CIDI screening questions are administered near the beginning of the interview, rather than at the beginning of each diagnostic module, to facilitate active memory search across the lifetime and to prevent under-endorsement of screening questions to avoid further questioning (Kessler & Ustun, 2004). This structure of the interview has been shown to be more sensitive to identifying true cases.

Lastly, the suicidality variables were limited in this study by the questions on the CIDI. The dependent variables, Suicidal Ideation and Suicide Attempts, were dichotomous variables. In addition, no additional information about intent was gathered about suicide attempts outside of the last 12 months, making it difficult to distinguish between true suicide attempts and suicide gestures. Taken together, these results are limited to people who were available to enroll in a study, endorsed at least some level of psychopathology to be interviewed on key disorders, believed that they had made a suicide attempt, and who had not committed suicide.

Notwithstanding the limitations, the data for this study were drawn from a large epidemiological community-based sample, allowing for more generalizability of the

results to the population of the United States than a clinical sample. Clinical samples have often been criticized for higher rates of comorbidity, more severe presentations of disorders (Regier et al., 1990), and reliance on people seeking treatment for a given disorder. Treatment seeking for mental health is highly variable depending on diagnosis, with a large number of people never seeking help for disorders (Wang, Berglund et al., 2005). Data from the NCS-R study demonstrated that most people (59%) with a psychiatric disorder in the last 12 months did not receive treatment for their disorder (Wang, Lane et al., 2005). Given the low rates of mental health service use, community samples provide a significant advantage over clinical samples in capturing a more generalizable sample of individuals with mental health problems.

Latent Variables

Each of the single factors analyzed (Negative Mood, Impulsivity, and Arousal) suggested the need for refinements to hypothesized symptom dimensions. That is, the original factors proposed were not supported by the data. The Negative Mood factor was better accounted for by two distinct factors, an emotion factor and a cognitive factor. Impulsivity was defined strictly by the symptoms of substance use disorders. Arousal was better explained by two factors, a negative emotional arousal factor and a non-emotional arousal factor. Negative Emotional Arousal was not independent from Negative Mood, and these two factors were subsequently combined. I begin by reviewing methodological issues that influenced the ability to develop these factors, as these issues influence the interpretation of the findings.

In this study, the originally proposed Negative Mood factor was better characterized by two distinct factors: a Negative Mood factor characterized by *worry*,

anhedonia, and *emptiness*, and a Negative Thinking factor defined by *low self-esteem*, *worthlessness/guilt*, and *hopelessness*. The emergence of two distinct factors was not an artifact of missing data. Although these results did not support initially proposed factors, they are intriguing and consistent with cognitive research on depression. Beck's theory posits that a cognitive style consisting of negative self-schemata revolving around themes of inadequacy, failure, loss, and worthlessness confers vulnerability or risk for developing episodes of depression and contributes to the severity and persistence of depression (Abramson, Metalsky, & Alloy, 1989; Beck, 1987; Teasdale, 1983; Teasdale, 1985). Consistent with Beck, Teasdale proposed a theory of differential activation to explain cognitive vulnerability to depression. Specifically, the degree of activation, and content of, negative thinking patterns that are accessed during the depressed state will determine whether the depression becomes more severe or persistent (Lau, Segal, & Williams, 2004). Research has demonstrated that those persons with a history of depressive episodes show more negative thinking during a dysphoric mood than normal controls, concluding that dysphoric moods are qualitatively different in those who show a cognitive vulnerability to depression (Teasdale, Lloyd, & Hutton, 1998). Moreover, negative cognitions have been shown to influence the maintenance and exacerbation of negative mood states (Teasdale, 1985). There is new research to suggest that this model is applicable to specific thinking patterns of hopelessness and suicidal ideation. That is, an early association between depressed mood and hopelessness/suicidal ideation leads to activation of these specific thinking patterns during future depressed moods (Joiner 2002, Joiner & Rudd, 2002). Taken together, differential activation of negative thinking,

including hopelessness and suicidal ideation, may be an essential distinguishing feature in a model of suicide.

Although previous research has shown that impulsivity is a characteristic of several psychiatric disorders including substance use, mania, impulse control disorders and personality disorders, this study did not support an impulsivity factor that encompassed symptoms from all of these disorders. Rather, impulsivity was best characterized by symptoms derived from the substance use modules. This may be due to the low base rates of mania and impulse control disorders in the NCS-R. In addition, personality disorders were assessed a screening questionnaire from the International Personality Disorder Examination. The screening questions are not designed to generate a clinical diagnosis, and therefore may not be as thorough as questions in other modules (Lenzenweger, Lane, Loranger, & Kessler, 2007). Beyond study-related limitations, however, research has demonstrated that impulsivity is a multi-faceted construct, and it is possible that these disorders may be characterized by different types of impulsivity. In one study, impulsivity was defined by two separate factors: negative emotional impulsivity and positive emotional impulsivity, and each facet of impulsivity differentially predicted major depressive disorder, risk for mania, risk for borderline personality disorder, and alcohol use disorders (Nam, Eisner, Johnson, & Carver, 2009). Thus, symptoms of impulsivity across different disorders may not represent a single impulsivity factor. In sum, it is important to note that the Recurrent Substance Use factor in this study does not account for impulsivity that may be present in other disorders.

Parallel to the difficulties highlighted above with measurement of impulsivity-related symptoms, some of the symptoms of arousal were drawn from the PTSD module

which was administered to only 10% of the sample. Three symptoms had to be removed from the analyses because they did not meet the minimum coverage requirement, and missing data patterns for other symptoms may have affected their coherence with other symptoms of arousal. Mplus can include a variable in a model as long as 10% of the sample has valid data on that variable. As such, the arousal symptoms under study were limited to *panic attacks*, *psychomotor activation*, *irritability/anger*, *insomnia*, *racing thoughts*, *talkativeness*, and *distractibility/difficulty concentrating*. An Arousal factor with indicators of *panic attacks*, *psychomotor activation*, *irritability or anger*, and *racing thoughts* demonstrated the best model fit. One possible explanation for a lack of coherence of *insomnia*, *talkativeness*, and *distractibility* with the other indicators may be related to the quantity of missing data for these indicators. These variables did, however, cohere with one another and were highly correlated with the Negative Emotional Arousal factor. Another plausible explanation is that these three arousal symptoms represent a Non-Emotional Arousal factor, which is distinct from the Negative Emotional Arousal factor characterized by negative emotionally charged panic attacks, PMA, and anger. This underlying negative emotional arousal may also account for the weak loadings of the *racing thoughts* indicator, a more neutral indicator, which was maintained in the model based on previous research findings. When incorporated into structural equation models, the Non-Emotional Arousal factor did not predict suicidal ideation or suicide attempts, and was ultimately removed from analyses in order to identify the most informative and parsimonious model of suicidality. Taken together, it appears that symptoms of negative emotional arousal may be more useful than non-emotional symptoms of arousal in predicting suicidal ideation and suicide attempts. Hence the

initial hypothesis concerning arousal as a factor distinct from negative mood in predicting suicidality was not supported.

When all three factors were examined together using confirmatory factor analysis techniques, the Negative Mood and Negative Emotional Arousal factors were highly correlated, and an examination of nested models suggested that these factors should be combined. Thus, the originally proposed Arousal factor was not supported. Despite the lack of support for the original hypothesis, the Negative Mood/Emotional Arousal factor parallels dimensions identified within other research on the structure of psychopathology. Krueger and colleagues describe a higher order internalizing factor that encompasses symptoms of depression, anxious worry, anxious arousal, neurasthenia, somatization, and hypochondriasis (Krueger, Chentsova-Dutton, Markon, Goldberg, & Ormel, 2003). The Negative Mood/Emotional Arousal factor from this study resembles this internalizing factor, with symptoms of depression, anxious worry, and anxious arousal as indicators. Symptoms of neurasthenia, somatization, and hypochondriasis were not examined in this study, as the symptoms studied were chosen specifically because they were hypothesized to relate to suicidality.

In sum, analyses of symptom dimensions yielded three factors: Negative Mood/Emotional Arousal, Negative Thinking, and Recurrent Substance Use. These three factors were moderately correlated with one another. Despite the fact that a core goal of this study was to create a transdiagnostic model, none of these factors are truly transdiagnostic. Negative Mood/Emotional Arousal and Negative Thinking include items from major depressive and anxiety disorders. The indicators of Recurrent Substance Use were drawn solely from the substance abuse modules. Nonetheless, the measurement

model captures symptom dimensions across a range of severity, and this may be more coherent than symptom counts for different disorders. This measurement model was the basis for subsequent structural equation modeling.

Predictors of Suicidal Ideation

It was hypothesized that Negative Mood would predict Suicidal Ideation (Hypothesis 2), and this was confirmed. Negative Mood/Emotional Arousal was a strong predictor of Suicidal Ideation, even after controlling for Negative Thinking. Negative Thinking, although correlated with Suicidal Ideation, did not predict Suicidal Ideation, after controlling for Negative Mood/Emotional Arousal. In this study, Negative Mood/Emotional Arousal, characterized by anhedonia, anger/irritability, and anxiety, was common among people who thought about suicide.

Predictors of Suicide Attempts

The direct effects of Negative Mood/Emotional Arousal, Suicidal Ideation, Negative Thinking, and Recurrent Substance Use on Suicide Attempts were examined. It was hypothesized (Hypothesis 2) that Suicidal Ideation would mediate the relationship between Negative Mood/Emotional Arousal and Suicide Attempts. This hypothesis was supported by the data, although mediation could not be tested using structural equation modeling. Negative Mood/Emotional Arousal, controlling for Negative Thinking, was a significant predictor of Suicide Attempts when Suicidal Ideation was not included in the model; however, when Suicidal Ideation was introduced, the relationship between Negative Mood/Emotional Arousal and Suicide Attempts was no longer significant. That is, Negative Mood/Emotional Arousal exhibited an indirect effect on Suicide Attempts via Suicidal Ideation. When all predictors were included in the model, Negative

Mood/Emotional Arousal was the only significant predictor of Suicidal Ideation. Suicidal Ideation, Negative Thinking and Recurrent Substance Use were significant predictors of Suicide Attempts. Taken together, Suicidal Ideation, Negative Thinking, and Recurrent Substance Use were direct predictors of Suicide Attempts (Hypothesis 5). The influence of Negative Mood/Emotional Arousal on Suicide Attempts was better accounted for by the presence of Suicidal Ideation.

When Suicide Attempts was entered into the model as a continuous variable, the model did not fit the data. This finding suggests that the three dimensions were predictive of whether someone will make a suicide attempt, but were not adequate in predicting the number of suicide attempts. This may be due to the fact the number of attempts was highly skewed. People who are making an extremely high number of suicide attempts may be engaging in parasuicidal behavior, whereby they lack the intent to die from their self-injurious behavior. Research has shown that it is important to differentiate between people who self-injure with and without intent to die, as those with intent sustain more medically serious injuries and are more likely to complete suicide (Brown, Henriques, Sosdjan, & Beck, 2004; Harriss, Hawton, & Zahl, 2005 as cited in Nock & Kessler, 2006).

Hypothesis 3 stated that Impulsivity would moderate the relationship between Negative Mood/Emotional Arousal and Suicide Attempts. Consistent with this hypothesis, the interaction between the modified impulsivity factor, Recurrent Substance Use, and Negative Mood/Emotional Arousal was a significant predictor of suicide attempts. That is, as negative mood increases, a person with high levels of recurrent substance use is at the greatest risk for making a suicide attempt. The same analyses were

executed examining the interaction between Negative Thinking and Recurrent Substance Use as a predictor of suicide attempts. The interaction was not significant. That is, Negative Thinking and Recurrent Substance Use demonstrated independent, direct relationships with Suicide Attempts.

These results provide evidence for two distinct pathways that lead to a suicide attempt. First, results demonstrated a direct relationship between Negative Thinking and Suicide Attempts. This is consistent with cognitive theories on suicidality. Beck theorized that suicidal behavior was the result of negative cognitive distortions and hopelessness, although hopelessness has emerged as the central variable that is consistently related to suicidality (Brown, Jeglic, Henriques, & Beck, 2006). Across several studies, hopelessness has been associated with suicide attempts in depression and other disorders including bipolar disorder, psychotic disorders, and substance use disorders. This study suggests, though, that cognitive factors in suicide attempts go beyond hopelessness to include low self-esteem and worthlessness or guilt. This is consistent with other research in both community and clinical samples that have found lower self-esteem among suicide attempters compared to people who did not attempt suicide (Angst, Degonda, & Ernst, 1992; Palmer, 2004). Similar findings demonstrate that negative thinking about the self and future, including low self-esteem and hopelessness, dominate the depressive symptom profile in child and adolescent suicide attempters and predict future suicide attempts independent of depression (Lewinsohn, Clarke, Seeley, & Rohde, 1994; Nruham, Larsson, & Sund, 2008). Taken together, the relationship between negative thinking and suicide attempts provides additional support for a cognitive theory of

suicidality, and evidence that low self-esteem and worthlessness may be more useful than just hopelessness alone in explaining suicide attempts.

The interaction between Negative Mood/Emotional Arousal and Recurrent Substance Use is the second pathway that predicted suicide attempts. This is consistent with research showing an association between comorbid mood and substance use disorders and suicidal behavior. It is well documented that major depressive disorder and alcoholism are the two most common diagnoses among suicide attempters (Fawcett, Clark, & Busch, 1993; Henriksson, Aro, Marttunen, & Heikkinen, 1993; Petronis, Samuels, Moscicki, & Anthony, 1990; Rudd et al., 1993; Winokur & Black, 1987). Comorbid alcohol use disorders and major depression place people at even greater risk for a suicide attempt. Disproportionately higher levels of suicidality are seen in depressed alcoholics compared to nonalcoholic patients with major depression (Cornelius, Salloum, Mezzich, & Cornelius, 1995). Studies have also consistently shown that people with drug dependence who make a suicide attempt have more lifetime comorbidity with major depression and alcohol dependence (Johnsson & Fridell, 1997; Roy, 2001; Roy, 2003). Speculatively, the common thread in this interaction may be low serotonergic functioning, which has been implicated in the etiology of suicidality, excessive alcohol use, impulsivity, psychological disorders characterized by impulsivity, and depression (Carver, Johnson, & Joormann, 2008; Cornelius et al., 1995).

Future directions

Future research on symptom predictors of suicidal ideation and attempts should include multi-faceted assessment of all psychiatric symptoms of interest. Including self-report symptom checklists may allow for a more extensive assessment of symptoms,

resolving the issue related to missing data that occurs when people do not endorse the screening question for a given disorder. The instrument used in this study also assessed symptoms in a dichotomous (yes/no) format. Continuous response formats would provide richer information for constructing latent variables. In addition, laboratory paradigms could be used to assess different facets of impulsivity.

Study design must also be considered when conducting research on suicidality. It will be important to integrate symptom-based models with other social, psychological and biological variables (i.e., demographics, life satisfaction, aggression, serotonergic function, antidepressant treatment) that may influence the relationship with suicide outcomes. In particular, the model should be compared across genders given that distinct risk factors have been identified for suicide attempts for males and females. Longitudinal research is necessary to further understand the relationship between key psychiatric symptoms and suicidality. In addition, prospective studies are the only way to understand what symptoms predict completed suicide.

Clinical Implications

This study has important clinical implications for both the assessment and treatment of suicidality. Negative Thinking was highly associated with making a suicide attempt after controlling for symptoms of Negative Mood/Emotional Arousal and Recurrent Substance Use. Assessments of suicidality by clinicians across psychiatric disorders should extend beyond ideation, plan or intent to include an in-depth assessment of the client's negative thoughts. Clinicians must also assess for the presence of a comorbid substance use disorder, in particular among patients who present with depression.

With regards to treatment, cognitive-behavioral therapies (CBT) with an integrated problem-solving component have demonstrated positive results with reductions in suicidal ideation (Joiner, Rudd, & Rajab, in press; Liberman & Echman, 1981; Salkovkis, Atha & Storer, 1990), depression (Lerner & Club, 1990; Liberman & Echman, 1981), and hopelessness (Brown et al., 2005; Salkovskis, Atha, & Storer, 1990). In a randomized controlled trial of cognitive therapy (CT) for suicide attempters, those who received CT did not differ significantly from the control group on a clinician-rated assessment of depression at any follow-up time point; the CT group did, however, demonstrate lower levels of hopelessness at six-month follow-up and was 50% less likely to attempt suicide at follow-up. The differential impact of cognitive therapy on depression and hopelessness is intriguing given the differential relationship of Suicide Attempts with Negative Mood/Emotional Arousal and Negative Thinking. An essential aim of treatment interventions for suicide must be to reduce levels of hopelessness. This study also suggests that improving feelings of low self-esteem and worthlessness may also be useful targets for intervention beyond hopelessness.

In addition, dialectical behavior therapy (DBT), developed to treat impulsive parasuicidal behavior common among people with borderline personality disorder, has consistently demonstrated efficacy in reducing suicide attempts, emergency department utilization, and inpatient psychiatric treatment for suicidal ideation, compared to individuals engaged in non-behavioral therapy by experts (Linehan, Armstrong, Suarez, & Allmon, 1991; Linehan et al., 2006; Moeller et al., 2001). It will be important to identify the active ingredients of cognitive and dialectical behavior therapies that are most effective in reducing hopelessness, impulsivity, and suicidal behavior.

Lastly, successful public health interventions can also prevent suicide attempts by reducing access to means, thereby making it more difficult for a person to act impulsively. Some examples of public health interventions include removing gas ovens, constructing barriers at jumping sites, decreasing the toxicity of antidepressants, restricting the prescription and sale of barbiturates, requiring catalytic converters in motor vehicles to reduce carbon monoxide emissions, and enacting gun control laws (Mann et al., 2005). These prevention efforts have been linked to lower suicide rates by the given method, and no increase has been seen in the use of other methods. In this study, recurrent substance use was a key factor that predicted suicide attempts, in particular, as individuals had increasing negative mood symptoms. Two studies that have shown that restricting access to alcohol has led to a decline in the suicide rate in Iceland and the former Union of Soviet Socialist Republics (Lester, 1999; Wasserman & Varnik, 1998). These studies, together with the results of this study, suggest that reducing access to substances may be an important target for public health interventions related to suicide. Overall, reducing access to means results in fewer impulsive suicides and does not necessarily lead to an increase in the use of other methods.

In sum, future research on suicide interventions should focus on determining the ‘active ingredients’ from treatments that have successfully reduced suicidal behavior and substance use disorders. Researchers should aim to develop interventions for suicide that can target underlying risk factors for suicidality and that are brief and cost-effective enough to be widely disseminated.

References

- Abramson, L. Y., Metalsky, G. I., & Alloy, L. B. (1989). Hopelessness depression: A theory-based subtype of depression. *Psychological Review*, *96*(2), 358-372.
- Aharonovich, E., Liu, X., Nunes, E., & Hasin, D. S. (2002). Suicide attempts in substance abusers: Effects of major depression in relation to substance use disorders. *American Journal of Psychiatry*, *159*(9), 1600-1602.
- Akiskal, H. S., & Benazzi, F. (2005a). Optimizing the detection of bipolar II disorder in outpatient private practice: Toward a systematization of clinical diagnostic wisdom. *Journal of Clinical Psychiatry*, *66*, 914-921.
- Akiskal, H. S., & Benazzi, F. (2005b). Psychopathologic correlates of suicidal ideation in major depressive outpatients: Is it all due to unrecognized (bipolar) depressive mixed states? *Psychopathology*, *38*(5), 273-280.
- Akiskal, H. S., Benazzi, F., Berugi, G., & Rihmer, Z. (2005). Agitated "unipolar" depression re-conceptualized as a depressive mixed state: Implications for the antidepressant-suicide controversy. *Journal of Affective Disorders*, *85*(3), 245-258.
- Alessi, N. E., McManus, M., Brickman, A., & Grapentine, L. (1984). Suicidal behavior among serious juvenile offenders. *American Journal of Psychiatry*, *141*(2), 286-287.
- Allen, M. H., Chessick, C. A., Miklowitz, D. J., Goldberg, J. F., Wisniewski, S. R., Miyahara, S., et al. (2005). Contributors to suicidal ideation among bipolar patients with and without a history of suicide attempts. *Suicide and Life-Threatening Behavior*, *35*(6), 671-680.
- Altamura, A. C., Bassetti, R., Bignotti, S., Pioli, R., & Mundo, E. (2003). Clinical variables related to suicide attempts in schizophrenia patients: A retrospective study. *Schizophrenia Research*, *60*(1), 47-55.
- Anderson, S. (2008, July 6). The urge to end it. *New York Times*. Retrieved September 22, 2008, from <http://www.nytimes.com>.
- Angst, J., Degonda, M., & Ernst, C. (1992). The Zurich study: XV. Suicide attempts in a cohort from age 20 to 30. *European Archives of Psychiatry and Clinical Neuroscience*, *242*(2), 135-141.
- Balazs, J., Benazzi, F., Rihmer, Z., Rihmer, A., Akiskal, K. K., & Akiskal, H. S. (2006). The close link between suicide attempts and mixed (bipolar) depression: Implications for suicide prevention. *Journal of Affective Disorders*, *91*(2-3), 133-138.

- Baron, R. M., & Kenny, D. A. (1986). The moderator-mediator variable distinction in social psychological research: Conceptual, strategic, and statistical considerations. *Journal of Personality and Social Psychology, 51*(6), 1173-1182.
- Baumeister, Roy F. (1990). Suicide as escape from self. *Psychological Review, 97*(1), 90-113.
- Beautrais, A. L., Joyce, P. R., & Mulder, R. T. (1999). Cannabis abuse and serious suicide attempts. *Addiction, 94*(8), 1155-1164.
- Beautrais, A. L., Joyce, P. R., Mulder, R. T., & Fergusson, D. M. (1996). Prevalence and comorbidity of mental disorders in persons making serious suicide attempts: A case-control study. *American Journal of Psychiatry, 153*(8), 1009-1014.
- Beck, A. T. (1987). Cognitive models of depression. *Journal of Cognitive Psychotherapy, 1*(1), 5-37.
- Beck, A. T., Brown, G., & Steer, R. A. (1989). Prediction of eventual suicide in psychiatric inpatients by clinical ratings of hopelessness. *Journal of Consulting and Clinical Psychology, 57*(2), 309-310.
- Beck, A. T., Kovacs, M., & Weissman, A. (1975). Hopelessness and suicidal behavior: An overview. *JAMA: Journal of the American Medical Association, 234*(11), 1146-1149.
- Beck, A. T., Steer, R. A., Beck, J. S., & Newman, C. F. (1993). Hopelessness, depression, suicidal ideation, and clinical diagnosis of depression. *Suicide and Life-Threatening Behavior, 23*(2), 139-145.
- Beck, A. T., Steer, R. A., Kovacs, M., & Garrison, B. (1985). Hopelessness and eventual suicide: A 10-year prospective study of patients hospitalized with suicidal ideation. *American Journal of Psychiatry, 142*(5), 559-563.
- Beck, A. T., Steer, R. A., Sanderson, W. C., & Skeie, T. M. (1991). Panic disorder and suicidal ideation and behavior: Discrepant findings in psychiatric outpatients. *American Journal of Psychiatry, 148*(9), 1195-1199.
- Beck, A. T., Weissman, A., Lester, D., & Trexler, L. (1974). The measurement of pessimism: The hopelessness scale. *Journal of Consulting and Clinical Psychology, 42*(6), 861-865.
- Biro, M., Selakovic-Bursic, S., & Kapamadzija, B. (1991). The role of depressive disorder in the suicidal behavior of alcoholics. *Crisis: The Journal of Crisis Intervention and Suicide Prevention, 12*(1), 64-68.

- Bollen, K. A. (1989). *Structural equations with latent variables*. New York: John Wiley & Sons.
- Borges, G., Angst, J., Nock, M. K., Ruscio, A. M., & Kessler, R. C. (2008). Risk factors for the incidence and persistence of suicide-related outcomes: A 10-year follow-up study using the National Comorbidity Surveys. *Journal of Affective Disorders, 105*(1-3), 25-33.
- Borges, G., Angst, J., Nock, M. K., Ruscio, A. M., Walters, E. E., & Kessler, R. C. (2006). A risk index for 12-month suicide attempts in the National Comorbidity Survey Replication (NCS-R). *Psychological Medicine, 36*(12), 1747-1757.
- Brezo, J., Paris, J., & Turecki, G. (2006). Personality traits as correlates of suicidal ideation, suicide attempts, and suicide completions: A systematic review. *Acta Psychiatrica Scandinavica, 113*(3), 180-206.
- Brodsky, B. S., Malone, K. M., Ellis, S. P., Dulit, R. A., & Mann, J. J. (1997). Characteristics of borderline personality disorder associated with suicidal behavior. *American Journal of Psychiatry, 154*(12), 1715-1719.
- Brown, G. K., Have, T. T., Henriques, G. R., Xie, S. X., Hollander, J. E., & Beck, A. T. (2005). Cognitive therapy for the prevention of suicide attempts: A randomized controlled trial. *JAMA: Journal of the American Medical Association, 294*(5), 563-570.
- Brown, G. K., Henriques, G. R., Sosdjan, D., & Beck, A. T. (2004). Suicide intent and accurate expectations of lethality: Predictors of medical lethality of suicide attempts. *Journal of Consulting and Clinical Psychology, 72*(6), 1170-1174.
- Brown, G. K., Jeglic, E., Henriques, G. R., & Beck, A. T. (2006). Cognitive therapy, cognition, and suicidal behavior. In T. E. Ellis (Ed.), (pp. 53-74). Washington, DC: American Psychological Association.
- Carver, C. S., Johnson, S. L., & Joormann, J. (2008). Serotonergic function, two-mode models of self-regulation, and vulnerability to depression: What depression has in common with impulsive aggression. *Psychological Bulletin, 134*(6), 912-943.
- Center for Disease Control. (2008). Suicide. Retrieved September 23, 2008 from http://www.cdc.gov/ncipc/dvp/suicide/suicide_data_sheet.pdf.
- Cohen, S., Lavelle, J., Rich, C. L., & Bromet, E. (1994). Rates and correlates of suicide attempts in first-admission psychotic patients. *Acta Psychiatrica Scandinavica, 90*(3), 167-171.

- Cohen, S., Leonard, C. V., Farberow, N. L., & Shneidman, E. S. (1964). Tranquilizers and suicide in the schizophrenic patient. *Archives of General Psychiatry*, *11*(3), 312-321.
- Cole, D. A. (1988). Hopelessness, social desirability, depression, and parasuicide in two college student samples. *Journal of Consulting and Clinical Psychology*, *56*(1), 131-136.
- Conner, K. R., Li, Y., Meldrum, S., Duberstein, P. R., & Conwell, Y. (2003). The role of drinking in suicidal ideation: Analyses of project MATCH data. *Journal of Studies on Alcohol*, *64*, 402-408.
- Cornelius, J. R., Salloum, I. M., Mezzich, J., & Cornelius, M. D. (1995). Disproportionate suicidality in patients with comorbid major depression and alcoholism. *American Journal of Psychiatry*, *152*(3), 358-364.
- Corruble, E., Damy, C., & Guelfi, J. D. (1999). Impulsivity: A relevant dimension in depression regarding suicide attempts? *Journal of Affective Disorders*, *53*(3), 211-215.
- Cottler, L. B., Campbell, W., Krishna, V. A. S., Cunningham-Williams, R. M., & Abdullah, A. B. (2005). Predictors of high rates of suicidal ideation among drug users. *Journal of Nervous and Mental Disease*, *193*(7), 431-437.
- Cox, B. J., Dorenfeld, D. M., Swinson, R. P., & Norton, G. R. (1994). Suicidal ideation and suicide attempts in panic disorder and social phobia. *American Journal of Psychiatry*, *151*(6), 882-887.
- Cox, B. J., Enns, M. W., & Clara, I. P. (2004). Psychological dimensions associated with suicidal ideation and attempts in the national comorbidity survey. *Suicide and Life-Threatening Behavior*, *34*(3), 209-219.
- Critchfield, K. L., Levy, K. N., & Clarkin, J. F. (2004). The relationship between impulsivity, aggression, and impulsive-aggression in borderline personality disorder: An empirical analysis of self-report measures. *Journal of Personality Disorders*, *18*(6), 555-570.
- Dahlsgaard, K. K., Beck, A. T., & Brown, G. K. (1998). Inadequate response to therapy as a predictor of suicide. *Suicide and Life-Threatening Behavior*, *28*(2), 197-204.
- Darke, S., & Ross, J. (1997). Polydrug dependence and psychiatric comorbidity among heroin injections. *Drug and Alcohol Dependence*, *48*(2), 135-141.
- Darke, S., & Ross, J. (2002). Suicide among heroin users: Rates, risk factors and methods. *Addiction*, *97*(11), 1383-1394.

- Darke, S., Ross, J., Williamson, A., Mills, K. L., Havard, A., & Teesson, M. (2007). Patterns and correlates of attempted suicide by heroin users over a 3-year period: Findings from the Australian treatment outcome study. *Drug and Alcohol Dependence*, 87(2-3), 146-152.
- Dervaux, A., Bayle, F. J., Laqueille, X., Bourdel, M., Le Borgne, M., Olie, J., et al. (2001). Is substance abuse in schizophrenia related to impulsivity, sensation seeking, or anhedonia? *American Journal of Psychiatry*, 158(3), 492-494.
- Diaconu, G., & Turecki, G. (2007). Panic disorder and suicidality: Is comorbidity with depression the key? *Journal of Affective Disorders*, 104(1-3), 203-209.
- Dinwiddie, S. H., Reich, T., & Cloninger, C. R. (1992). Psychiatric comorbidity and suicidality among intravenous drug users. *Journal of Clinical Psychiatry*, 53(10), 364-369.
- Disney, E. R., Elkins, I. J., McGue, M., & Iacono, W. G. (1999). Effects of ADHD, conduct disorder, and gender of substance use and abuse in adolescence. *American Journal of Psychiatry*, 156(10), 1515-1521.
- Dougherty, D. M., Bjork, J. M., Huckabee, H. C. G., Moeller, F. G., & Swann, A. C. (1999). Laboratory measures of aggression and impulsivity in women with borderline personality disorder. *Psychiatry Research*, 85(3), 315-326.
- Dougherty, D. M., Mathias, C. W., Marsh, D. M., Moeller, F. G., & Swann, A. C. (2004). Suicidal behaviors and drug abuse: Impulsivity and its assessment. *Drug and Alcohol Dependence*, 76(Suppl7), S93-S105.
- Drake, R. E., & Cotton, P. G. (1986). Depression, hopelessness and suicide in chronic schizophrenia. *British Journal of Psychiatry*, 148, 554-559.
- Drake, R. E., Gates, C., Whitaker, A., & Cotton, P. G. (1985). Suicide among schizophrenics: A review. *Comprehensive Psychiatry*, 26(1), 90-100.
- Driessen, M., Veltrup, C., Weber, J., John, U., Wetterling, T., & Dilling, H. (1998). Psychiatric co-morbidity, suicidal behaviour and suicidal ideation in alcoholics seeking treatment. *Addiction*, 93(6), 889-894.
- Dunner, D. L., Gershon, E. S., & Goodwin, F. K. (1976). Heritable factors in the severity of affective illness. *Biological Psychiatry*, 11, 31-42.
- Dyer, J. A., & Kreitman, N. (1984). Hopelessness, depression and suicidal intent in parasuicide. *British Journal of Psychiatry*, 144, 127-133.

- Enders, C. K. (2006). Analyzing structural equation models with missing data. In G. R. Hancock, & R. O. Mueller (Eds.), *A second course in structural equation modeling* (pp. 315-344). Greenwich, CT: Information Age.
- Fawcett, J., Clark, D. C., & Busch, K. A. (1993). Assessing and treating the patient at risk for suicide. *Psychiatric Annals*, *23*(5), 244-255.
- Fawcett, J., Scheftner, W., Clark, D., & Hedeker, D. (1987). Clinical predictors of suicide in patients with major affective disorders: A controlled prospective study. *American Journal of Psychiatry*, *144*(1), 35-40.
- Finney, S. J., & DiStefano, C. (2006). Nonnormal and categorical data in structural equation models. In G. R. Hancock, & R. O. Mueller (Eds.), *A second course in structural equation modeling* (pp. 269-314). Greenwich, CT: Information Age.
- First, M. B., Spitzer, R. L., Williams, J. B. W., & Gibbon, M. (1997). *Structured clinical interview for DSM-IV (SCID)*. Washington DC: American Psychiatric Association.
- Freeman, T. W., & Moore, W. M. (2000). A comparison of chronic combat-related posttraumatic stress disorder (PTSD) patients with and without a history of suicide attempt. *Journal of Nervous and Mental Disease*, *188*(7), 460-463.
- Friedman, S., Jones, J. C., Chernen, L., & Barlow, D. H. (1992). Suicidal ideation and suicide attempts among patients with panic disorder: A survey of two outpatient clinics. *American Journal of Psychiatry*, *149*(5), 680-685.
- Friedman, S., Smith, L., & Fogel, D. (1999). Suicidality in panic disorder: A comparison with schizophrenic, depressed, and other anxiety disorder outpatients. *Journal of Anxiety Disorders*, *13*(5), 447-461.
- Garvey, M. J., & Spoden, F. (1980). Suicide attempts in antisocial personality disorder. *Comprehensive Psychiatry*, *21*(2), 146-149.
- Goh, S. E., Salmons, P. H., & Whittington, R. M. (1989). Hospital suicides: Are there preventable factors? Profile of the psychiatric hospital suicide. *British Journal of Psychiatry*, *154*, 247-249.
- Gupta, S., Black, D. W., Arndt, S., Hubbard, W. C., & Andreasen, N. C. (1998). Factors associated with suicide attempts among patients with schizophrenia. *Psychiatric Services*, *49*(10), 1353-1355.
- Gut-Fayand, A., Dervaux, A., Olie, J., Loo, H., Poirier, M., & Krebs, M. (2001). Substance abuse and suicidality in schizophrenia: A common risk factor linked to impulsivity. *Psychiatry Research*, *102*(1), 65-72.

- Harkavy-Friedman, J. M., Nelson, E. A., Venarde, D. F., & Mann, J. J. (2004). Suicidal behavior in schizophrenia and schizoaffective disorder: Examining the role of depression. *Suicide and Life-Threatening Behavior, 34*(1), 66-76.
- Harkavy-Friedman, J. M., Restifo, K., Malaspina, D., Kaufmann, C. A., Amador, X. F., Yale, S. A., et al. (1999). Suicidal behavior in schizophrenia: Characteristics of individuals who had and had not attempted suicide. *American Journal of Psychiatry, 156*(8), 1276-1278.
- Haro, J. M., Arbabzadeh-Bouchez, S., Brugha, T. S., Girolamo, G., Guyer, M. E., Jin, R., et al. (2006). Concordance of the composite international diagnostic interview version 3.0 (CIDI 3.0) with standardized clinical assessments in the WHO world mental health surveys. *International Journal of Methods in Psychiatric Research, 15*(4), 167-180.
- Harris, E. C., & Barraclough, B. (1997). Suicide as an outcome for mental disorders: A meta-analysis. *British Journal of Psychiatry, 170*(3), 205-228.
- Harriss, L., Hawton, K., & Zahl, D. (2005). Value of measuring suicidal intent in the assesment of people attenidng hospital following self-poisoning or self-injury. *British Journal of Psychiatry, 186*, 60-66.
- Hawton, K., Sutton, L., Haw, C., Sinclair, J., & Harriss, L. (2005). Suicide and attempted suicide in bipolar disorder: A systematic review of risk factors. *Journal of Clinical Psychiatry, 66*(6), 693-704.
- Henriksson, M. M., Aro, H. M., Marttunen, M. J., & Heikkinen, M. E. (1993). Mental disorders and comorbidity in suicide. *American Journal of Psychiatry, 150*(6), 935-940.
- Holmes, R. M., & Holmes, S. T. (2005). *Suicide: Theory, practice and investigation*. Thousand Oaks, CA: Sage Publications, Inc.
- Horesh, N., Gothelf, D., Ofek, H., Weizman, T., & Apter, A. (1999). Impulsivity as a correlate of suicidal behavior in adolescent psychiatric inpatients. *Crisis: The Journal of Crisis Intervention and Suicide Prevention, 20*(1), 8-14.
- Horesh, N., Rolnick, T., Iancut, I., Dannon, P., Lepkifker, E., Apter, A., et al. (1997). Anger, impulsivity and suicide risk. *Psychotherapy and Psychosomatics, 66*(2), 92-96.
- Hornig, C. D., & McNally, R. J. (1995). Panic disorder and suicide attempt: A reanalysis of data from the epidemiologic catchment area study. *British Journal of Psychiatry, 167*(1), 76-79.

- Jenkins, R., Bhugra, D., Meltzer, H., Singleton, N., Bebbington, P., Brugha, T., et al. (2005). Psychiatric and social aspects of suicidal behaviour in prisons. *Psychological Medicine*, 35(2), 257-269.
- Johnson, J., Weissman, M. M., & Klerman, G. L. (1990). Panic disorder, comorbidity, and suicide attempts. *Archives of General Psychiatry*, 47(9), 805-808.
- Johnson, S. L., McMurrich, S., & Yates, M. (2005). Suicidality in bipolar I disorder. *Suicide and Life-Threatening Behavior*, 35(6), 681-689.
- Johnsson, E., & Fridell, M. (1997). Suicide attempts in a cohort of drug abusers: A 5-year follow-up study. *Acta Psychiatrica Scandinavica*, 96(5), 362-366.
- Joiner, T. E. (2002). The trajectory of suicidal behavior over time. *Suicide and Life-Threatening Behavior*, 32, 33-41.
- Joiner, T. E. J., Brown, J. S., & Wingate, L. R. (2005). The psychology and neurobiology of suicidal behavior. *Annual Review of Psychology*, 56, 287-314.
- Joiner, T. E., & Rudd, M. D. (2000) Intensity and duration of suicidal crises vary as a function of previous suicide attempts and negative life events. *Journal of Consulting and Clinical Psychology*, 68, 909-916.
- Joiner, T., Rudd, M., & Rajab, M. (in press). An intriguing interaction between comorbid diagnostic status and treatment type in predicting treatment response among suicidal young adults. *American Journal of Psychiatry*.
- Kempton, T., & Forehand, R. L. (1992). Suicide attempts among juvenile delinquents: The contribution of mental health factors. *Behaviour Research and Therapy*, 30(5), 537-541.
- Kendler, K. S. (1996). Major depression and generalised anxiety disorder same genes, (partly) different environments--revisited. *British Journal of Psychiatry*, 168(Suppl 30), 68-75.
- Kessler, R. C. (1994). The National Comorbidity Survey of the United States. *International Review of Psychiatry*, 6(4), 365-376.
- Kessler, R. C., Abelson, J., Demler, O., Escobar, J. I., Gibbon, M., Guyer, M. E., et al. (2004). Clinical calibration of DSM-IV diagnoses in the world mental health (WMH) version of the World Health Organization (WHO) composite international diagnostic interview (WMH-CIDI). *International Journal of Methods in Psychiatric Research*, 13(2), 122-139.

- Kessler, R. C., Berglund, P., Borges, G., Nock, M., & Wang, P. S. (2005). Trends in suicide ideation, plans, gestures, and attempts in the United States, 1990-1992 to 2001-2003. *JAMA: Journal of the American Medical Association*, *293*(20), 2487-2495.
- Kessler, R. C., Berglund, P., Chiu, W. T., Demler, O., Heeringa, S., Hiripi, E., et al. (2004). The US National Comorbidity Survey Replication (NCS-R): Design and field procedures. *International Journal of Methods in Psychiatric Research*, *13*(2), 69-92.
- Kessler, R. C., Borges, G., & Walters, E. E. (1999). Prevalence of and risk factors for lifetime suicide attempts in the National Comorbidity Survey. *Archives of General Psychiatry*, *56*(7), 617-626.
- Kessler, R. C., Chiu, W. T., Demler, O., & Walters, E. E. (2005). Prevalence, severity, and comorbidity of 12-month DSM-IV disorders in the National Comorbidity Survey Replication. *Archives of General Psychiatry*, *62*(6), 617-627.
- Kessler, R. C., & Merikangas, K. R. (2004). The National Comorbidity Survey Replication (NCS-R): Background and aims. *International Journal of Methods in Psychiatric Research*, *13*(2), 60-68.
- Kessler, R. C., & Ustun, T. B. (2004). The world mental health (WMH) survey initiative version of the World Health Organization (WHO) composite international diagnostic interview (CIDI). *International Journal of Methods in Psychiatric Research*, *13*(2), 93-121.
- Kessler, R. C., Wittchen, H. U., Abelson, J. M., McGonagle, K. A., Schwarz, N., Kendler, K. S., et al. (1998). Methodological studies of the composite international diagnostic interview (CIDI) in the US National Comorbidity Survey. *International Journal of Methods in Psychiatry Research*, *7*, 33-55.
- Kirby, K. N., Petry, N. M., & Bickel, W. K. (1999). Heroin addicts have higher discount rates for delayed rewards than non-drug-using controls. *Journal of Experimental Psychology: General*, *128*(1), 78-87.
- Kline, R. B. (2005). *Principles and practice of structural equation modeling* (2nd ed.). New York: The Guilford Press.
- Korszun, A., Moskvina, V., Brewster, S., Craddock, N., Ferrero, F., Gill, M., et al. (2004). Familiality of symptom dimensions in depression. *Archives of General Psychiatry*, *61*(5), 468-474.
- Koukopoulos, A., & Koukopoulos, A. (1999). Agitated depression as a mixed state and the problem of melancholia. *Psychiatric Clinics of North America*, *22*(3), 547-564.

- Kovacs, M., Beck, A. T., & Weissman, A. (1975). Hopelessness: An indicator of suicidal risk. *Suicide*, 5, 98-103.
- Krueger, R. F., Chentsova-Dutton, Y. E., Markon, K. E., Goldberg, D., & Ormel, J. (2003). A cross-cultural study of the structure of comorbidity among common psychopathological syndromes in the general health care setting. *Journal of Abnormal Psychology*, 112(3), 437-447.
- Lau, M. A., Segal, Z. V., & Williams, M. G. (2004). Teasdale's differential activation hypothesis: implications for mechanisms of depressive relapse and suicidal behaviour. *Behaviour Research and Therapy*, 42, 1001-1017.
- Lenzenweger, M. F., Lane, M. C., Loranger, A. W., & Kessler, R. C. (2007). DSM-IV personality disorders in the National Comorbidity Survey Replication. *Biological Psychiatry*, 62(6), 553-564.
- Lepine, J. P., Chignon, J. M., & Teherani, M. (1993). Suicide attempts in patients with panic disorder. *Archives of General Psychiatry*, 50(2), 144-149.
- Lester, D. (1999). Effect of changing alcohol laws in Iceland on suicide rates. *Psychological Reports*, 84(2), 1158.
- Lewinsohn, P. M., Clarke, G. N., Seeley, J. R., & Rohde, P. (1994). Major depression in community adolescents: Age at onset, episode duration, and time to recurrence. *Journal of the American Academy of Child & Adolescent Psychiatry*, 33(6), 809-818.
- Lerner, M. S., & Clum, G. A. (1990). Treatment of suicide ideators: A problem-solving approach. *Behavior Therapy*, 21, 403-411.
- Liberman, R. P., & Eckman, T. (1981). Behavior therapy vs. insight-oriented therapy for repeated suicide attempters. *Archives of General Psychiatry*, 38, 1126-1130.
- Linehan, M. M., Armstrong, H. E., Suarez, A., & Allmon, D. (1991). Cognitive-behavioral treatment of chronically parasuicidal borderline patients. *Archives of General Psychiatry*, 48(12), 1060-1064.
- Linehan, M. M., Comtois, K. A., Murray, A. M., Brown, M. Z., Gallop, R. J., Heard, H. L., et al. (2006). Two-year randomized controlled trial and follow-up of dialectical behavior therapy vs therapy by experts for suicidal behaviors and borderline personality disorder. *Archives of General Psychiatry*, 63(7), 757-766.
- Links, P. S., Heslegrave, R., & van Reekum, R. (1999). Impulsivity: Core aspect of borderline personality disorder. *Journal of Personality Disorders*, 13(1), 1-9.
- Logue, A. W. (1995). *Self-control: Waiting for tomorrow for what you want today*. Englewood Cliffs, N.J.: Prentice-Hall.

- Madden, G. J., Petry, N. M., Badger, G. J., & Bickel, W. K. (1997). Impulsive and self-control choices in opioid-dependent patients and non-drug-using control patients: Drug and monetary rewards. *Experimental and Clinical Psychopharmacology*, *5*(3), 256-262.
- Maj, M., Pirozzi, R., Magliano, L., & Bartoli, L. (2003). Agitated depression in bipolar I disorder: Prevalence, phenomenology, and outcome. *American Journal of Psychiatry*, *160*(12), 2134-2140.
- Malone, K. M., Haas, G. L., Sweeney, J. A., & Mann, J. J. (1995). Major depression and the risk of attempted suicide. *Journal of Affective Disorders*, *34*(3), 173-185.
- Maloney, E., Degenhardt, L., Darke, S., Mattick, R. P., & Nelson, E. (2007). Suicidal behaviour and associated risk factors among opioid-dependent individuals: A case-control study. *Addiction*, *102*(12), 1933-1941.
- Mann, J. J., Apter, A., Bertolote, J., Beautrais, A. L., Currier, D., & Haas, A. (2005). Suicide prevention strategies: A systematic review. *Journal of the American Medical Association*, *294*(16), 2064-2074.
- Mann, J. J., Waternaux, C., Haas, G. L., & Malone, K. M. (1999). Toward a clinical model of suicidal behavior in psychiatric patients. *American Journal of Psychiatry*, *156*(2), 181-189.
- Mannuzza, S., Aronowitz, B., Chapman, T., & Klein, D. F. (1992). Panic disorder and suicide attempts. *Journal of Anxiety Disorders*, *6*(3), 261-274.
- Marshall, R. D., Olfson, M., Hellman, F., Blanco, C., Guardino, M., & Struening, E. L. (2001). Comorbidity, impairment, and suicidality in subthreshold PTSD. *American Journal of Psychiatry*, *158*(9), 1467-1473.
- McCloud, A., Barnaby, B., Omu, N., Drummond, C., & Aboud, A. (2004). Relationship between alcohol use disorders and suicidality in a psychiatric population: In-patient prevalence study. *British Journal of Psychiatry*, *184*(5), 439-445.
- Meltzer, H. Y., Anand, R., & Alphs, L. (2000). Reducing suicide risk in schizophrenia: Focus on the role of clozapine. *CNS Drugs*, *14*(5), 355-365.
- Michaelis, B. H., Goldberg, J. F., Davis, G. P., Singer, T. M., Garno, J. L., & Wenzel, S. J. (2004). Dimensions of impulsivity and aggression associated with suicide attempts among bipolar patients: A preliminary study. *Suicide and Life-Threatening Behavior*, *34*(2), 172-186.

- Minkoff, K., Bergman, E., Beck, A. T., & Beck, R. (1973). Hopelessness, depression, and attempted suicide. *American Journal of Psychiatry*, *130*(4), 455-459.
- Moeller, F. G., Barratt, E. S., Dougherty, D. M., Schmitz, J. M., & Swann, A. C. (2001). Psychiatric aspects of impulsivity. *American Journal of Psychiatry*, *158*(11), 1783-1793.
- Moscicki, E. K. (1994). Gender differences in completed and attempted suicides. *Annals of Epidemiology*, *4*, 152-158.
- Moscicki, E. K. (1997). Identification of suicide risk factors using epidemiologic studies. *Psychiatric Clinics of North America*, *20*(3), 499-517.
- Moscicki, E. K. (2001). Epidemiology of completed and attempted suicide: Toward a framework for prevention. *Clinical Neuroscience Research*, *1*, 310-323.
- Moss, H. B., Yao, J. K., & Panzak, G. L. (1990). Serotonergic responsivity and behavioral dimensions in antisocial personality disorder with substance abuse. *Biological Psychiatry*, *28*(4), 325-338.
- Muthén, L. K., & Muthén, B. O. (1998-2007). *Mplus user's guide* (4th ed.). Los Angeles, CA: Author.
- Nam, J., Eisner, L., Johnson, S. L., & Carver, C. S. (2009). *Using confirmatory factor analysis and structural equation modeling to understand facets of impulsivity and the relationship with psychopathology*. Manuscript in preparation.
- Nock, M. K., & Kessler, R. C. (2006). Prevalence of and risk factors for suicide attempts versus suicide gestures: Analysis of the National Comorbidity Survey. *Journal of Abnormal Psychology*, *115*(3), 616-623.
- Nrugham, L., Larsson, B., & Sund, A. M. (2008). Specific depressive symptoms and disorders as associates and predictors of suicidal acts across adolescence. *Journal of Affective Disorders*, *111*(1), 83-93.
- Olgiate, P., Serretti, A., & Colombo, C. (2006). Retrospective analysis of psychomotor agitation, hypomanic symptoms, and suicidal ideation in unipolar depression. *Depression and Anxiety*, *23*(7), 89-397.
- Oquendo, M., Brent, D. A., Birmaher, B., Greenhill, L., Kolko, D., Stanley, B., et al. (2005). Posttraumatic stress disorder comorbid with major depression: Factors mediating the association with suicidal behavior. *American Journal of Psychiatry*, *162*(3), 560-566.

- Oquendo, M. A., Friend, J. M., Halberstam, B., Brodsky, B. S., Burke, A. K., Grunebaum, M. F., et al. (2003). Association of comorbid posttraumatic stress disorder and major depression with greater risk for suicidal behavior. *American Journal of Psychiatry*, *160*(3), 580-582.
- Oquendo, M. A., Lizardi, D., Greenwald, S., Weissman, M. M., & Mann, J. J. (2004). Rates of lifetime suicide attempt and rates of lifetime major depression in different ethnic groups in the United States. *Acta Psychiatrica Scandinavica*, *110*(6), 446-451.
- Oquendo, M. A., Waternaux, C., Brodsky, B., Parsons, B., Haas, G. L., Malone, K. M., et al. (2000). Suicidal behavior in bipolar mood disorder: Clinical characteristics of attempters and nonattempters. *Journal of Affective Disorders*, *59*(2), 107-117.
- Palmer, C. J. J. (2004). Suicide attempt history, self-esteem, and suicide risk in a sample of 116 depressed voluntary inpatients. *Psychological Reports*, *95*(3), 1092-1094.
- Patton, J. H., Stanford, M. S., & Barratt, E. S. (1995). Factor structure of the Barratt Impulsiveness Scale. *Journal of Clinical Psychology*, *51*(6), 768-774.
- Peluso, M. A. M., Hatch, J. P., Glahn, D. C., Monkul, E. S., Sanches, M., Najt, P., et al. (2007). Trait impulsivity in patients with mood disorders. *Journal of Affective Disorders*, *100*(1-3), 227-231.
- Perugi, G., Akiskal, H. S., Micheli, C., Toni, C., & Madaro, D. (2001). Clinical characterization of depressive mixed state in bipolar-1 patients: Pisa-San Diego collaboration. *Journal of Affective Disorders*, *67*(1-3), 105-114.
- Petrie, K., & Chamberlain, K. (1983). Hopelessness and social desirability as moderator variables in predicting suicidal behavior. *Journal of Consulting and Clinical Psychology*, *51*(4), 485-487.
- Petronis, K. R., Samuels, J. F., Moscicki, E. K., & Anthony, J. C. (1990). An epidemiologic investigation of potential risk factors for suicide attempts. *Social Psychiatry and Psychiatric Epidemiology*, *25*(4), 193-199.
- Placidi, G. P. A., Oquendo, M. A., Malone, K. M., Brodsky, B., Ellis, S. P., & Mann, J. J. (2000). Anxiety in major depression: Relationship to suicide attempts. *American Journal of Psychiatry*, *157*(10), 1614-1618.
- Plutchik, R., & Van Praag, H. (1989). The measurement of suicidality, aggressivity and impulsivity. *Progress in Neuro-Psychopharmacology & Biological Psychiatry*, *13*(Suppl), S23-S34.
- Putnins, A. L. (1995). Recent drug use and suicidal behaviour among young offenders. *Drug and Alcohol Review*, *14*, 151-158.

- Regier, D. A., Farmer, M. E., Rae, D. S., Locke, B. Z., Keith, S. J., Judd, L. L., et al. (1990). Comorbidity of mental disorders with alcohol and other drug abuse: Results from the Epidemiologic Catchment Area (ECA) study. *Journal of the American Medical Association*, 264(19), 2511-2518.
- Roy, A. (1982). Risk factors for suicide in psychiatric patients. *Archives of General Psychiatry*, 39(9), 1089-1095.
- Roy, A. (2001). Characteristics of cocaine-dependent patients who attempt suicide. *American Journal of Psychiatry*, 158(8), 1215-1219.
- Roy, A. (2002). Characteristics of opiate dependent patients who attempt suicide. *Journal of Clinical Psychiatry*, 63(5), 403-407.
- Roy, A. (2003). Characteristics of drug addicts who attempt suicide. *Psychiatry Research*, 121(1), 99-103.
- Roy, A., DeJong, J., Lamparski, D., & Adinoff, B. (1991). Mental disorders among alcoholics: Relationship to age of onset and cerebrospinal fluid neuropeptides. *Archives of General Psychiatry*, 48(5), 423-427.
- Rudd, M. D., Dahm, P. F., & Rajab, M. H. (1993). Diagnostic comorbidity in persons with suicidal ideation and behavior. *American Journal of Psychiatry*, 150(6), 928-834.
- Rusch, K. M., Guastello, S. J., & Mason, P. T. (1992). Differentiating symptom clusters of borderline personality disorder. *Journal of Clinical Psychology*, 48(6), 730-738.
- Salkovskis, P. M., Atha, C., & Storer, D. (1990). Cognitive-behavioural problem solving in the treatment of patients who repeatedly attempt suicide: A controlled trial. *British Journal of Psychiatry*, 157, 871-876.
- Sareen, J., Cox, B. J., Afifi, T. O., de Graaf, R., Asmundson, G. J. G., ten Have, M., et al. (2005). Anxiety disorders and risk for suicidal ideation and suicide attempts: A population-based longitudinal study of adults. *Archives of General Psychiatry*, 62(11), 1249-1257.
- Sareen, J., Cox, B. J., Stein, M. B., Afifi, T. O., Fleet, C., & Asmundson, G. J. G. (2007). Physical and mental comorbidity, disability, and suicidal behavior associated with posttraumatic stress disorder in a large community sample. *Psychosomatic Medicine*, 69(3), 242-248.
- Sareen, J., Houlahan, T., Cox, B. J., & Asmundson, G. J. G. (2005). Anxiety disorders associated with suicidal ideation and suicide attempts in the National Comorbidity Survey. *Journal of Nervous and Mental Disease*, 193(7), 450-454.

- Schatzberg, A. F., & DeBattista, C. (1999). Phenomenology and treatment of agitation. *Journal of Clinical Psychiatry, 60*(Suppl 15), 17-20.
- Schuckit, M. A., Tipp, J. E., Bergman, M., & Reich, W. (1997). Comparison of induced and independent major depressive disorders in 2,945 alcoholics. *American Journal of Psychiatry, 154*(7), 948-957.
- Shahar, G., Bareket, L., Rudd, M. D., & Joiner, T. E. J. (2006). In severely suicidal young adults, hopelessness, depressive symptoms, and suicidal ideation constitute a single syndrome. *Psychological Medicine, 36*(7), 913-922.
- Simon, T. R., Swann, A. C., Powell, K. E., Potter, L. B., Kresnow, M., & O'Carroll, P. W. (2001). Characteristics of impulsive suicide attempts and attempters. *Suicide and Life-Threatening Behavior, 32*(Suppl), 49-59.
- Soloff, P. H., Lis, J. A., Kelly, T., Cornelius, J., & Ulrich, R. (1994). Risk factors for suicidal behavior in borderline personality disorder. *The American Journal of Psychiatry, 151*(9), 1316-1323.
- Soloff, P. H., Lynch, K. G., & Kelly, T. M. (2002). Childhood abuse as a risk factor for suicidal behavior in borderline personality disorder. *Journal of Personality Disorders, 16*(3), 201-214.
- Steer, R. A., Kumar, G., & Beck, A. T. (1993). Self-reported suicidal ideation in adolescent psychiatric inpatients. *Journal of Consulting and Clinical Psychology, 61*(6), 1096-1099.
- Sullivan, P. F., Kessler, R. C., & Kendler, K. S. (1998). Latent class analysis of lifetime depressive symptoms in the National Comorbidity Survey. *American Journal of Psychiatry, 155*(10), 1398-1406.
- Sullivan, P. F., Prescott, C. A., & Kendler, K. S. (2002). The subtypes of major depression in a twin registry. *Journal of Affective Disorders, 68*(2-3), 273-284.
- Suominen, K., Henriksson, M., Suokas, J., & Isometsa, E. (1996). Mental disorders and comorbidity in attempted suicide. *Acta Psychiatrica Scandinavica, 94*(4), 234-240.
- Suominen, K. H., Isometsa, E. T., Henriksson, M. M., Ostamo, A. I., & Lonnqvist, J. K. (2000). Suicide attempts and personality disorder. *Acta Psychiatrica Scandinavica, 102*(2), 118-125.
- Swann, A. C., Anderson, J. C., Dougherty, D. M., & Moeller, F. G. (2001). Measurement of inter-episode impulsivity in bipolar disorder. *Psychiatry Research, 101*(2), 195-197.

- Swann, A. C., Dougherty, D. M., Pazzaglia, P. J., Pham, M., & Moeller, F. G. (2004). Impulsivity: A link between bipolar disorder and substance abuse. *Bipolar Disorders*, 6(3), 204-212.
- Swann, A. C., Dougherty, D. M., Pazzaglia, P. J., Pham, M., Steinberg, J. L., & Moeller, F. G. (2005). Increased impulsivity associated with severity of suicide attempt history in patients with bipolar disorder. *American Journal of Psychiatry*, 162(9), 1680-1687.
- Swann, A. C., Janicak, P. L., Calabrese, J. R., Bowden, C. L., Dilsaver, S. C., Morris, D. D., et al. (2001). Structure of mania: Depressive, irritable, and psychotic clusters with different retrospectively-assessed course patterns of illness in randomized clinical trial participants. *Journal of Affective Disorders*, 67(1-3), 123-132.
- Swann, A. C., Steinberg, J. L., Lijffijt, M., & Moeller, F. G. (2008). Impulsivity: Differential relationship to depression and mania in bipolar disorder. *Journal of Affective Disorders*, 106(3), 241-248.
- Tcheremissine, O. V., Lane, S. D., Cherek, D. R., & Pietras, C. J. (2003). Impulsiveness and other personality dimensions in substance use disorders and conduct disorders. *Addictive Disorders & their Treatment*, 2(1), 1-7.
- Teasdale, J. D. (1983). Negative thinking in depression: Cause, effect, or reciprocal relationship. *Advances in Behaviour Research & Therapy*, 5(1), 3-25.
- Teasdale, J. D. (1985). Psychological treatments for depression: How do they work? *Behaviour Research and Therapy*, 23(2), 157-165.
- Teasdale, J. D., Lloyd, C., & Hutton, J. M. (1998). Depressive thinking and dysfunctional schematic mental models. *British Journal of Clinical Psychology*, 37(3), 247-257.
- Valtonen, H. M., Suominen, K., Mantere, O., Leppamaki, S., Arvilommi, P., & Isometsa, E. (2007). Suicidal behaviour during different phases of bipolar disorder. *Journal of Affective Disorders*, 97(1-3), 101-107.
- Verona, E., Hicks, B. M., & Patrick, C. J. (2005). Psychopathy and suicidality in female offenders: Mediating influences of personality and abuse. *Journal of Consulting and Clinical Psychology*, 73(6), 1065-1073.
- Verona, E., Patrick, C. J., & Joiner, T. E. (2001). Psychopathy, antisocial personality, and suicide risk. *Journal of Abnormal Psychology*, 110(3), 462-470.
- Vickers, K., & McNally, R. J. (2004). Panic disorder and suicide attempt in the National Comorbidity Survey. *Journal of Abnormal Psychology*, 113(4), 582-591.

- Wang, P. S., Berglund, P., Olfson, M., Pincus, H. A., Wells, K. B., & Kessler, R. C. (2005). Failure and delay in initial treatment contact after first onset of mental disorders in the National Comorbidity Survey Replication. *Archives of General Psychiatry*, *62*(6), 603-613.
- Wang, P. S., Lane, M., Olfson, M., Pincus, H. A., Wells, K. B., & Kessler, R. C. (2005). Twelve-month use of mental health services in the United States: Results from the National Comorbidity Survey Replication. *Archives of General Psychiatry*, *62*(6), 629-640.
- Warman, D. M., Forman, E. M., Henriques, G. R., Brown, G. K., & Beck, A. T. (2004). Suicidality and psychosis: Beyond depression and hopelessness. *Suicide and Life-Threatening Behavior*, *34*(1), 77-86.
- Warshaw, M. G., Massion, A. O., Peterson, L. G., & Pratt, L. A. (1995). Suicidal behavior in patients with panic disorder: Retrospective and prospective data. *Journal of Affective Disorders*, *34*(3), 235-247.
- Wasserman, D., & Varnik, A. (1998). Suicide-preventive effects of perestroika in the former USSR: The role of alcohol restriction. *Acta Psychiatrica Scandinavica*, *S394*, 1-4.
- Weissman, M. M., Klerman, G. L., Markowitz, J. S., & Ouellette, R. (1989). Suicidal ideation and suicide attempts in panic disorder and attacks. *New England Journal of Medicine*, *321*(18), 1209-1214.
- Wen Hung, K., Gallo, J. J., & Eaton, W. W. (2004). Hopelessness, depression, substance disorder, and suicidality: A 13-year community-based study. *Social Psychiatry and Psychiatric Epidemiology*, *39*(6), 497-501.
- Wetzel, R. D., Margulies, T., Davis, R., & Karam, E. (1980). Hopelessness, depression, and suicide intent. *Journal of Clinical Psychiatry*, *41*(5), 159-160.
- Widiger, T. A., & Samuel, D. B. (2005). Diagnostic categories or dimensions? A question for the Diagnostic and Statistical Manual of Mental Disorders--Fifth Edition. *Journal of Abnormal Psychology*, *114*(4), 494-504.
- Winokur, G., & Black, D. W. (1987). Psychiatric and medical diagnoses as risk factors for mortality in psychiatric patients: A case-control study. *American Journal of Psychiatry*, *144*(2), 208-211.
- Wittchen, H. (1994). Reliability and validity studies of the WHO-composite international diagnostic interview (CIDI): A critical review. *Journal of Psychiatric Research*, *28*(1), 57-84.

- Yen, S., Shea, M. T., Sanislow, C. A., Grilo, C. M., Skodol, A. E., Gunderson, J. G., et al. (2004). Borderline personality disorder criteria associated with prospectively observed suicidal behavior. *American Journal of Psychiatry*, *161*(7), 1296-1298.
- Young, M. A., Fogg, L. F., Scheftner, W., Fawcett, J., Akiskal, H., & Maser, J. (1996). Stable trait components of hopelessness: Baseline and sensitivity to depression. *Journal of Abnormal Psychology*, *105*(2), 155-165.
- Young, S. E., Mikulich, S. K., Goodwin, M. B., & Hardy, J. (1995). Treated delinquent boys' substance use: Onset, pattern, relationship to conduct and mood disorders. *Drug and Alcohol Dependence*, *37*(2), 149-162.

Table 1

Prevalence of 12-Month Mental Disorders Among Respondents with 12-Month Suicidal Ideation and Attempts (Kessler et al., 2005)

	NCS		NCS-R	
	Ideation <i>N</i> = 210	Attempt <i>N</i> = 37	Ideation <i>N</i> = 205	Attempt <i>N</i> = 47
Mood Disorders				
MDD	41.9(4.3)	34.7 (10.0)	38.9 (3.0)	38.9 (5.6)
Dysthymia	4.4 (1.4)	6.1 (3.3)	8.0 (1.9)	7.4 (3.5)
Bipolar disorder	10.6 (2.6)	18.8 (7.5)	22.1 (3.3)	31.0 (5.9)
Any Mood Disorder	55.0 (5.1)	54.6 (10.3)	61.0 (4.6)	69.9 (7.2)
Anxiety Disorders				
GAD	12.4 (2.8)	8.2 (4.2)	12.1 (2.9)	15.5 (5.5)
Agoraphobia	11.7 (3.1)	17.4 (8.7)	4.0 (1.3)	6.8 (3.9)
Simple phobia	25.7 (3.9)	33.7 (8.5)	28.1 (3.3)	42.2 (7.4)
Social phobia	24.4 (4.1)	27.8 (6.7)	33.7 (3.1)	41.5 (5.9)
Panic disorder	11.3 (3.3)	18.2 (7.2)	19.7 (3.1)	35.1 (7.3)
Posttraumatic stress disorder	29.0 (3.6)	21.6 (7.7)	20.1 (3.3)	30.0 (5.8)
Any anxiety disorder	62.8 (5.1)	70.9 (6.0)	60.6 (3.2)	70.4 (5.4)
Substance disorders				
Alcohol abuse	24.6 (4.2)	44.9 (9.9)	16.2 (3.0)	18.9 (7.6)
Alcohol dependence	18.6 (3.4)	40.4 (9.5)	10.3 (2.6)	13.9 (6.7)
Drug abuse	18.8 (4.2)	28.2 (12.2)	7.3 (2.0)	14.8 (6.2)
Drug dependence	16.8 (4.3)	21.2 (10.0)	4.8 (1.6)	8.9 (4.5)

Any SUD	30.3 (4.6)	49.5 (10.2)	19.4 (3.6)	26.1 (9.1)
<hr/>				
Other disorders				
Conduct disorder			3.0 (1.3)	7.8 (3.9)
<hr/>				
Any disorder	80.5 (4.3)	88.7 (5.8)	82.0 (3.0)	88.2 (4.7)
<hr/>				

Table 2

Odds ratios for lifetime DSM-III and 12-month DSM-IV disorders with lifetime and 12-month suicidal ideation and attempts (Kessler et al., 1999; Borges et al., 2006)

	NCS (Lifetime)		NCS-R (12-month)	
	Ideation	Attempt	Ideation	Attempt *among ideators
Mood Disorders				
MDD	9.6(7.5-12.3)†	11.0(7.1-20.3)†	8.7(6.6-11.4)†	0.8(0.3-2.0)
Dysthymia	7.7(5.9-10.1)†	7.8(4.6-13.5)†	6.2(3.5-11.2)†	1.1(0.2-7.1)
Mania	15.5 (8.9-26.8)†	29.7 (11.7-75.1)†	9.6(6.4-14.3)†	1.7 (0.4-7.0)
Any Mood DO	10.7 (8.4-13.5)†	12.9 (7.8-21.3)†	14.8(10.5-20.9)†	1.2(0.4-3.8)
Anxiety Disorders				
GAD	4.2 (3.1-5.9)†	5.6 (2.8-11.1)†	4.9 (2.9-8.1)†	4.5 (1.4-14.4)†
Agoraphobia	2.9 (2.2-3.9)†	2.8 (1.6-5.1)†	5.1 (2.3-11.6)†	1.5 (0.0-59.8)
Simple phobia	2.9 (2.3-3.6)†	3.1 (1.8-5.3)†	4.1 (3.0-5.5)†	1.1 (0.4-3.3)
Social phobia	2.2 (1.7-2.9)†	2.1 (1.3-3.6)†	6.6 (4.8-9.2)†	1.7 (0.5-6.1)
Panic disorder	3.9 (2.8-5.3)†	5.6 (2.9-10.7)†	8.5 (6.1-12.0)†	1.0 (0.3-3.3)
PTSD	5.1 (3.9-6.8)†	6.0 (3.4-10.7)†	6.4 (4.2-9.5)†	1.0 (0.2-4.3)
Any Anxiety DO	2.8 (2.2-3.5)†	3.2 (2.0-5.2)†	7.2 (5.4-9.6)†	1.0 (0.2-4.6)
Substance disorders				
Alcohol abuse	3.4 (2.7-4.3)†	4.8 (2.8-8.1)†	4.8 (3.0-7.7)†	0.9 (0.2-4.2)
Alcohol Dep	4.6 (3.5-6.1)†	6.5 (3.6-11.5)†	7.4(3.7-14.8)†	0.6 (0.1-4.8)
Drug abuse	4.9 (3.8-6.1)†	5.9 (3.4-10.2)†	4.1(2.1-8.0)†	2.9 (0.7-11.6)
Drug Dep	5.3 (4.1-6.9)†	5.8 (3.3-10.1)†	11.2 (4.5-27.9)†	7.4 (2.0-27.5)†

Any SUD	3.9 (3.1-4.9)†	5.8 (3.5-9.7)†	5.1(3.2--8.2)†	0.9 (0.3-3.3)
Other disorders				
Conduct disorder	3.2 (2.6-3.9)†	4.2 (2.5-6.9)†	2.8 (1.1-7.2)†	7.3 (1.4-37.2)†
Adult antisocial behavior	4.2 (3.2-5.6)†	5.7 (3.1-10.3)†	Not reported	Not reported
Antisocial personality disorder	4.6 (3.2-6.5)†	5.7 (2.9-11.2)†	Not reported	Not reported
Nonaffective psychosis	4.2 (2.7-6.7)†	5.7 (2.6-12.4)†	Not reported	Not reported

Dep = Dependence; DO = Disorder; MDD = Major Depressive Disorder; PTSD

Posttraumatic Stress Disorder; SUD = Substance Use Disorder

† $p < .05$

Table 3

Summary of Composite Variables and Missing Data

Indicator	Variable Label	Factor*	Yes %	Yes	No %	No	Missing %	Missing	Total		Total		Total	
									Yes %	Yes	No %	No	Yes %	Yes
Panic attack	Fear or panic attack leaving frightened/anxious/uneasy	AR	3277 57.57%	2415 42.43%	0 0.00%	3672 64.51%	2020 35.49%	0 0.00%						
	Attack leads to phys symptoms/loss control/dire outcome	AR	346 6.08%	2069 36.35%	3277 57.57%									
	4 or more symptoms of Panic Attack that peak within 10 minutes	AR	2171 38.14%	3521 61.86%	0 0.00%									
	Severe dep episode-sudden attacks of intense fear or panic	AR	829 14.56%	1350 23.72%	3513 61.72%									
Psychomotor activation	Energetic/restless/talkative/unusual behavior period	AR	1245 21.87%	4444 78.07%	3 0.05%	1619 28.44%	4073 71.56%	0 0.00%						
	Irritable episode-so restless, couldn't sit still or paced	AR	582 10.22%	550 9.66%	4560 80.11%									
	In worst episode-lot more energy nearly every day	AR	60 1.05%	271 4.76%	5361 94.18%									
	In worst episode-nerv/jittery so can't sit still or pace	AR	113 1.99%	217 3.81%	5362 94.20%									
	Severe dep episode-more energy than usual most days	AR	94 1.65%	237 4.16%	5361 94.18%									
	Severe dep episode-so restless couldn't sit still or paced	AR	303 5.32%	713 12.53%	4676 82.15%									
	Worst episode in past year-physical arousal	AR	123 2.16%	101 1.77%	5468 96.06%									
	Irritable/grumpy/bad mood for several day period	AR	2593 45.56%	3098 54.43%	1 0.02%	3486 61.24%	2206 38.76%	0 0.00%						
	Irritation led to shout/argue/hit for several day period	AR	1018 17.88%	1575 27.67%	3099 54.44%									
	Worst episode in past year-irritable	AR	139 2.44%	85 1.49%	5468 96.06%									
Severe dep episode-felt irritable/grouchy/moody most days	AR	1335 23.45%	846 14.86%	3511 61.68%										
Period of being irritable + other problems for most of 2 weeks	AR	220 3.87%	634 11.14%	4838 85.00%										
Anger attacks occurred without good reason	AR	630 11.07%	1235 21.70%	3827 67.23%										

*NM = Negative Mood; AR = Arousal; IMP = Impulsivity

Indicator	Variable Label	Factor*	Yes	Yes %	No	No %	Missing	Miss %	Total		Total		Total	
									Yes	Yes %	No	No %	Miss	Miss %
Irritable / Anger (cont'd)	Anger occur in situations most people wouldn't have attack	AR	268	4.71%	943	16.57%	4481	78.72%						
	Lot more angry than most during attack	AR	365	6.41%	577	10.14%	4750	83.45%						
	Unavoidable impulse to blow-up before attack	AR	726	12.75%	534	9.38%	4432	77.86%						
	Anger out of control during typical attack	AR	845	14.85%	415	7.29%	4432	77.86%						
	Have tantrums/angry outbursts	AR	1438	25.26%	4248	74.63%	6	0.11%						
	Irritable during most affected time after worst event	AR	431	7.57%	323	5.67%	4938	86.75%						
	More irritable during most affected time after random event	AR	299	5.25%	265	4.66%	5128	90.09%						
Insomnia	Severe dep episode-trouble sleeping most nights	AR	1620	28.46%	540	9.49%	3532	62.05%	2262	39.74%	615	10.80%	2815	49.46%
	Severe dep episode-slept much less but not tired	AR	897	15.76%	918	16.13%	3877	68.11%						
	Worst episode in past year-quantity of sleep	AR	86	1.51%	137	2.41%	5469	96.08%						
	Irritable episode-sleep less than usual but not tired	AR	700	12.30%	426	7.48%	4566	80.22%						
	Trouble sleeping during most affected time after worst event	AR	616	10.82%	144	2.53%	4932	86.65%						
	Severe dep episode-jumping or racing thoughts hard to track	AR	344	6.04%	559	9.82%	4789	84.14%	1054	18.52%	806	14.16%	3832	67.32%
Racing thoughts	Irritable episode-thoughts jumping/racing unable to keep track	AR	776	13.63%	355	6.24%	4561	80.13%						
	Worst episode in past year-racing thoughts/disorg thinking	AR	134	2.35%	89	1.56%	5469	96.08%						
	Irritable episode-thoughts jumping/racing unable to keep track	AR	134	2.35%	89	1.56%	5469	96.08%						
Talkative	Worst episode in past year-talkative	AR	119	2.09%	105	1.84%	5468	96.06%	893	15.69%	239	4.20%	4560	80.11%
	Irritable episode-more int in sex than usual/diff partners	AR	247	4.34%	873	15.34%	4572	80.32%						
	Irritable episode-overly friendly with people	AR	524	9.21%	606	10.65%	4562	80.15%						

*NM = Negative Mood; AR = Arousal; IMP = Impulsivity

Indicator	Variable Label	Factor*	Yes	Yes %	No	No %	Missing	Miss %	Total Yes	Total Yes %	Total No	Total No %	Total Miss	Total Miss %
Talkative (cont'd)	Irritable episode-overly friendly with people	AR	524	9.21%	606	10.65%	4562	80.15%						
	Irritable episode-inappropriate behavior	AR	498	8.75%	634	11.14%	4560	80.11%						
	Irritable episode-talked more than usual	AR	632	11.10%	500	8.78%	4560	80.11%						
Distractible	Irritable episode-constantly change plans/activities	AR	570	10.01%	554	9.73%	4568	80.25%	1546	27.16%	543	9.54%	3603	63.30%
	Episode hard keep mind things	AR	669	11.75%	460	8.08%	4563	80.17%						
	In worst episode-trouble concentrating nearly every day	AR	229	4.02%	102	1.79%	5361	94.18%						
	Trouble concentrate during most affect time after worst event	AR	563	9.89%	200	3.51%	4929	86.60%						
Keyed up / On edge	Trouble concentrate during most affected time after rand evnt	AR	402	7.06%	165	2.90%	5125	90.04%						
	More alert during most affected time after worst event	AR	546	9.59%	223	3.92%	4923	86.49%	619	10.87%	152	2.67%	4921	86.45%
	Jumpy during most affected time after worst event	AR	499	8.77%	269	4.73%	4924	86.51%						
Hypervigilant	More alert/watchful during most affected time after rand evnt	AR	354	6.22%	215	3.78%	5123	90.00%						
	Jumpy during most affected time after random event	AR	314	5.52%	256	4.50%	5122	89.99%						
Sad mood	Sad/empty/depressed for several day period	NM	3576	62.83%	2115	37.16%	1	0.02%	4218	74.10%	1474	25.90%	0	0.00%
	Discouraged about life for several day period	NM	3723	65.41%	1969	34.59%	0	0.00%						
	Sad/depr episode - discouraged about life	NM	3182	55.90%	391	6.87%	2119	37.23%						
Sad episode several days almost every month for a year	Sadness episode lasted all day for 2+- wks	NM	2353	41.34%	1814	31.87%	1525	26.79%						
	Sad episode several days almost every month for a year	NM	289	5.08%	923	16.22%	4480	78.71%						

*NM = Negative Mood; AR = Arousal; IMP = Impulsivity

Indicator	Variable Label	Factor*	Yes	Yes %	No	No %	Missing	Miss %	Total Yes	Total Yes %	Total No	Total No %	Total Miss	Total Miss %
Sad Mood (cont'd)	Severe dep episode-felt depressed most days	NM	2075	36.45%	136	2.39%	3481	61.16%	3428	60.22%	2263	39.76%	1	0.02%
	Severe dep episode-nothing could cheer you most days	NM	1369	24.05%	705	12.39%	3618	63.56%						
	Sev dep episode-discounted about things in life most days	NM	1950	34.26%	262	4.60%	3480	61.14%						
	Severe dep episode-cried often	NM	1525	26.79%	658	11.56%	3509	61.65%						
	In worst ep-feel discouraged about how things going in life	NM	269	4.73%	60	1.05%	5363	94.22%						
	Lost interest in enjoyable things for several day period	NM	2890	50.77%	2796	49.12%	6	0.11%	3428	60.22%	2263	39.76%	1	0.02%
Anhedonia	Sad/depr episode - lost interest in enjoyable things	NM	2439	42.85%	736	12.93%	2517	44.22%						
	Sad/depr episode - lost interest in enjoyable things	NM	130	2.28%	263	4.62%	5299	93.10%						
	Discouraged about life episode - lost int in enjoy things	NM	244	4.29%	352	6.18%	5096	89.53%						
	Lost int in enjoy things episode - felt most of time 2+ wks	NM	54	0.95%	92	1.62%	5546	97.43%						
	Severe dep episode-lost int in things you used to think fun	NM	1713	30.09%	500	8.78%	3479	61.12%						
	Sev dep episode-nothing fun though good things happening	NM	1529	26.86%	679	11.93%	3484	61.21%						
	In worst episode-lose ability take pleasure in good happenings	NM	205	3.60%	124	2.18%	5363	94.22%						
	Worried more than others about same problems	NM	3154	55.41%	2505	44.01%	33	0.58%	3868	67.96%	1824	32.04%	0	0.00%
	More nervous/anxious than most with same problems	NM	278	4.88%	2227	39.13%	3187	55.99%						
	Anxious/worried most days for one month or more	NM	276	4.85%	1983	34.84%	3433	60.31%						
Hopeless	Severe dep episode-felt nervous or anxious most days	NM	1437	25.25%	744	13.07%	3511	61.68%						
	Severe dep episode-felt hopeless about future most days	NM	1359	23.88%	584	10.26%	3749	65.86%						
	Severe dep episode-lost self confidence	NM	1707	29.99%	465	8.17%	3520	61.84%	1772	31.13%	412	7.24%	3508	61.63%
Low self-esteem	Severe dep episode-felt not as good as others most days	NM	1347	23.66%	829	14.56%	3516	61.77%						

*NM = Negative Mood; AR = Arousal; IMP = Impulsivity

Indicator	Variable Label	Factor**	Yes	Yes %	No	No %	Missing	Miss %	Total Yes	Total Yes %	Total No	Total No %	Total Miss	Total Miss %
Worthless/ Severe dep episode-worthless feeling most days		NM	940	16.51%	404	7.10%	4348	76.39%	1434	25.19%	748	13.14%	3510	61.67%
Guilt Severe dep episode-felt guilty most days		NM	1159	20.36%	1017	17.87%	3516	61.77%						
Emptiness Often feel empty inside		NM	1354	23.79%	4331	76.09%	7	0.12%						
Inability to resist Anger attack leading to breaking item of some value		IMP	1808	31.76%	3883	68.22%	1	0.02%	3219	56.55%	2473	43.45%	0	0.00%
aggressive impulses Anger attack leading to hitting/attempt hitting person		IMP	1824	32.04%	3864	67.88%	4	0.07%						
Anger attack leading to threat of harm to person		IMP	884	15.53%	2983	52.41%	1825	32.06%						
Get so angry, I sometimes break/smash things		IMP	874	15.35%	4818	84.65%	0	0.00%						
Irritable episode-involved in foolish investments/money making		IMP	131	2.30%	1001	17.59%	4560	80.11%	1320	23.19%	4367	76.72%	5	0.09%
Excessive involvement in pleasurable activities Irritable episode-financial trouble due to spending too much		IMP	412	7.24%	719	12.63%	4561	80.13%						
Irritable episode-seeking pleasure doing risky things		IMP	447	7.85%	684	12.02%	4561	80.13%						
Take chances/do reckless things		IMP	950	16.69%	4736	83.20%	6	0.11%						
Gives into urges Giving into urges gets me in trouble		IMP	2472	43.43%	3210	56.39%	10	0.18%	2636	46.31%	3056	53.69%		
Ever had irresistible urge to drink		IMP	394	6.92%	4507	79.18%	791	13.90%						
Ever had irresistible urge to use drug		IMP	352	6.18%	4781	84.00%	559	9.82%						
Use larger amounts or longer period of time Ever drank more often than intended		IMP	105	1.84%	4077	71.63%	1510	26.53%	148	2.60%	4920	86.44%	624	10.96%
Used drugs when had no intention to		IMP	437	7.68%	4696	82.50%	559	9.82%						
Ever used drugs more than intended		IMP	55	0.97%	4641	81.54%	996	17.50%						
Cut down unsuccessful Ever unable to stop/cut down drinking when tried		IMP	431	7.57%	4472	78.57%	789	13.86%	516	9.07%	5119	89.93%	57	1.00%
Ever tried stop/cut down on drugs and not able		IMP	162	2.85%	4610	80.99%	920	16.16%						

*NM = Negative Mood; AR = Arousal; IMP = Impulsivity

Indicator	Variable Label	Factor*	Yes	Yes%	No	No%	Missing	Miss %	Total Yes	Total Yes %	Total No	Total No %	Total Miss	Total Miss %
Psychological or physical problem	Ever cont'd drinking though it caused phys or emo problems	IMP	415	7.29%	4485	78.79%	792	13.91%	545	9.57%	5117	89.90%	30	0.53%
	Ever cont'd drug use though it caused phys or emo problems	IMP	265	4.66%	4868	85.52%	559	9.82%						
Failure to fulfill role obligations	Alcohol/drugs interfered with responsibilities	IMP	81	1.42%	4417	77.60%	1194	20.98%	751	13.19%	4911	86.28%	30	0.53%
	Drinking ever interfered w/ work/school/job/home	IMP	582	10.22%	1887	33.15%	3223	56.62%						
Use in hazardous situations	Drug use frequently interfered with job/home/school	IMP	364	6.39%	5105	89.69%	223	3.92%						
	Ever jeopardized safety due to drinking	IMP	894	15.71%	1577	27.71%	3221	56.59%	1012	17.78%	4651	81.71%	29	0.51%
Social problems	Jeopardized safety due to drugs	IMP	546	9.59%	4924	86.51%	222	3.90%						
	Alcohol/drug use caused problems/argue with others	IMP	77	1.35%	4499	79.04%	1116	19.61%	874	15.35%	4790	84.15%	28	0.49%
	Drinking problem cause family/friend argue/probs	IMP	727	12.77%	1741	30.59%	3224	56.64%						
	Continue drinking though caused problem w/ people	IMP	648	11.38%	1381	24.26%	3663	64.35%						
Continued drug use regardless of problems w/ family/friends	Drug use caused problems/argue with family and friends	IMP	394	6.92%	5077	89.20%	221	3.88%						
	Continued drug use regardless of problems w/ family/friends	IMP	347	6.10%	4461	78.37%	884	15.53%						

*NIM = Negative Mood; AR = Arousal; IMP = Impulsivity

Table 4

Correlations and Partial Correlations of Factor Scores with Suicidal Ideation and Suicide Attempt

Factor Score	Suicidal Ideation				Suicide Attempt			
	SI	Control for NM/EA	Control for RSU	Control for all factors	Control for NM/EA	Control for RSU	Control for all factors	Control for all factors
Negative Mood/Emotional Arousal (NM/EA)	.46**	-----	.43**	.34**	.24**	-----	.16**	.08**
Negative Thinking (NT)	.19**	-.03*	-----	.08**	.23**	.13**	-----	.13**
Recurrent Substance Use (RSU)	.33**	.001	.28**	-----	.22**	.07**	.15**	.06**

Table 5

Negative Mood/Emotional Arousal as a Predictor of Suicide Attempts at Low, Mean, and High Levels of Recurrent Substance Use

Impulsivity	β	SE	Wald	df	<i>P</i>	OR	CI
Low	.89	.13	44.77	1	<.001	2.44	1.88 – 3.17
Mean	1.04	.11	96.87	1	<.001	2.84	2.31 – 3.49
High	1.19	.12	103.97	1	<.001	3.30	2.62 – 4.15

Figure Captions

- Figure 1.* Hypothesized measurement model of Negative Mood, Impulsivity, and Arousal.
- Figure 2.* Proposed mediation model. Suicidal Ideation will mediate the relationship between Negative Mood and Suicide Attempts.
- Figure 3.* Proposed full structural equation model relating Negative Mood, Impulsivity, and Arousal to Suicidal Ideation and Suicide Attempts. Impulsivity and Arousal will moderate the relationship between Negative Mood and Suicide Attempts.
- Figure 4.* Measurement model for Negative Mood and Negative Thinking.
- Figure 5.* Measurement model for Recurrent Substance Use.
- Figure 6.* Measurement model for Negative Emotional Arousal.
- Figure 7.* Measurement model for Negative Mood/Emotional Arousal and Negative Thinking.
- Figure 8.* Measurement model for Negative Mood/Emotional Arousal, Negative Thinking, and Recurrent Substance Use.
- Figure 9.* Structural equation model examining Negative Mood/Emotional Arousal and Negative Thinking as predictors of Suicidal Ideation.
- Figure 10.* Structural equation model examining Negative Mood/Emotional Arousal and Negative Thinking as predictors of Suicide Attempts.
- Figure 11.* Structural equation model demonstrating mediation of the relationship between Negative Mood/Emotional Arousal and Suicide Attempts by Suicidal Ideation, controlling for Negative Thinking.
- Figure 12.* Structural equation model showing the relationships among Negative Mood/Emotional Arousal, Negative Thinking, Recurrent Substance Use, Suicidal Ideation and Suicide Attempts.

Figure 1

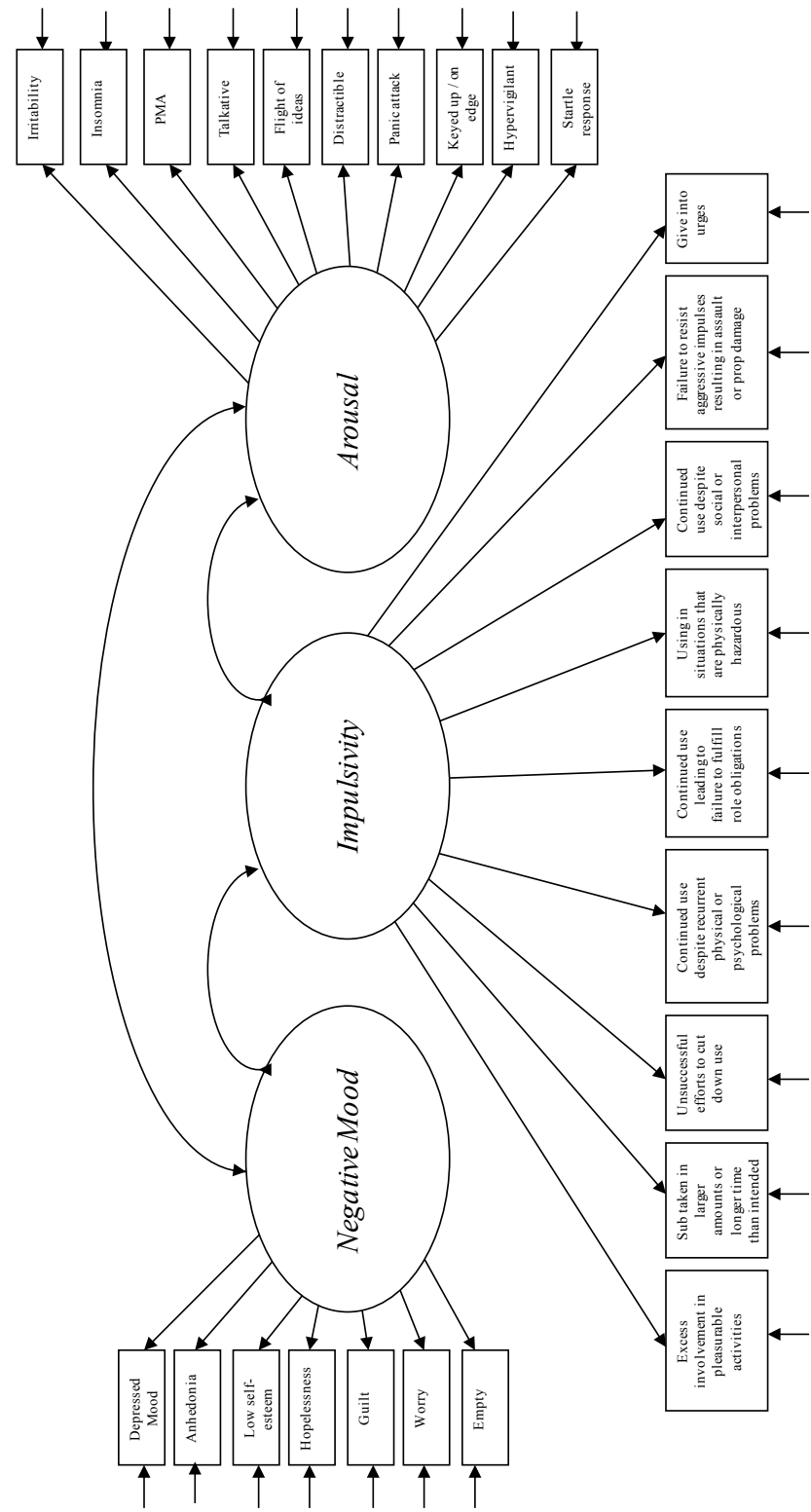

Figure 2

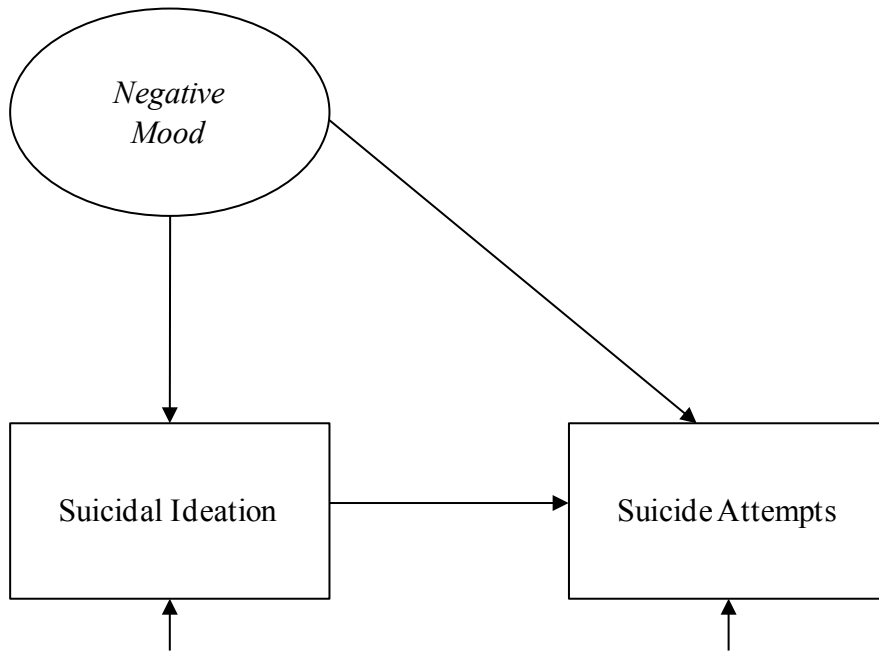

Figure 3

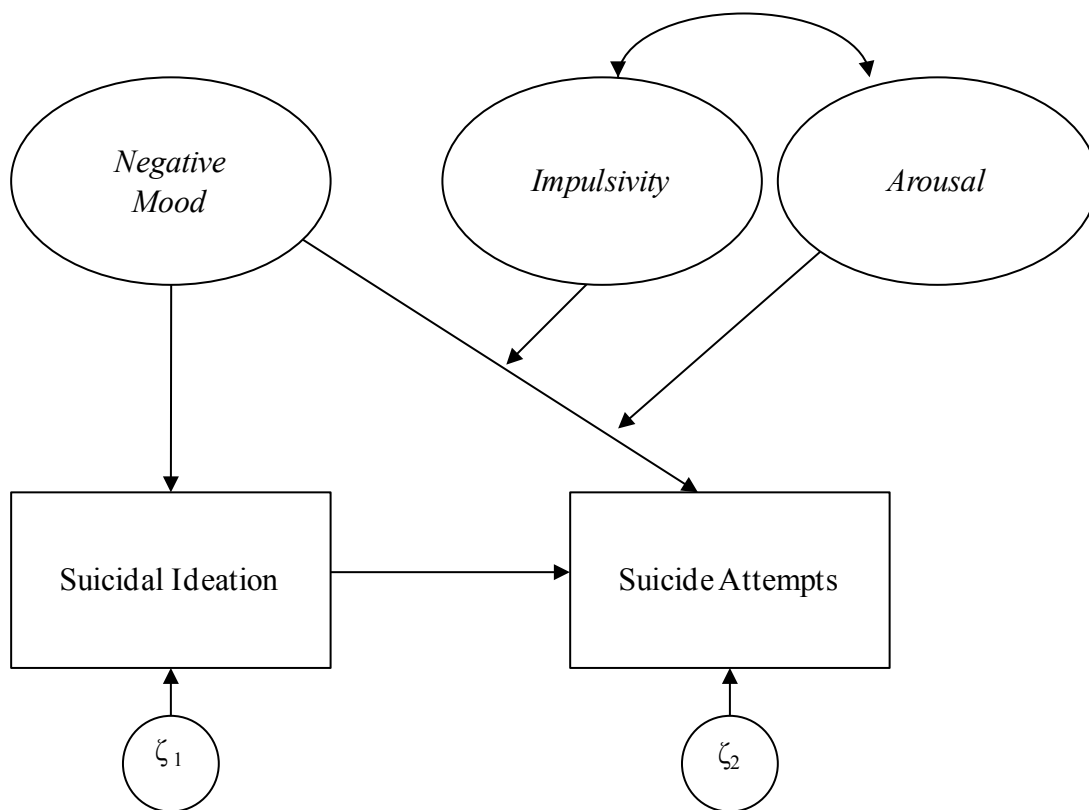
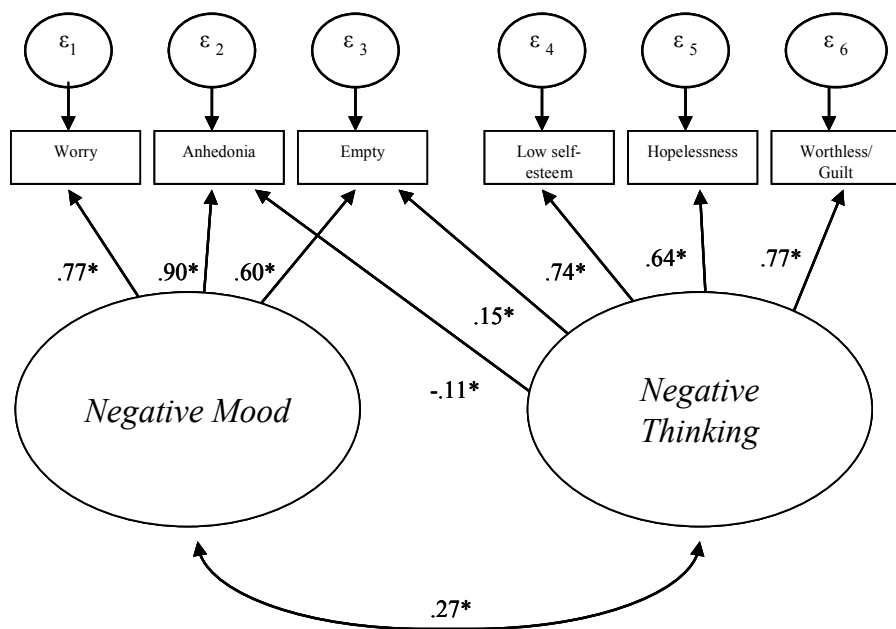

Figure 4



$\chi^2(5) = 3.69, p = .59$
CFI = 1.00
RMSEA = .00
WRMR = .38

Figure 5

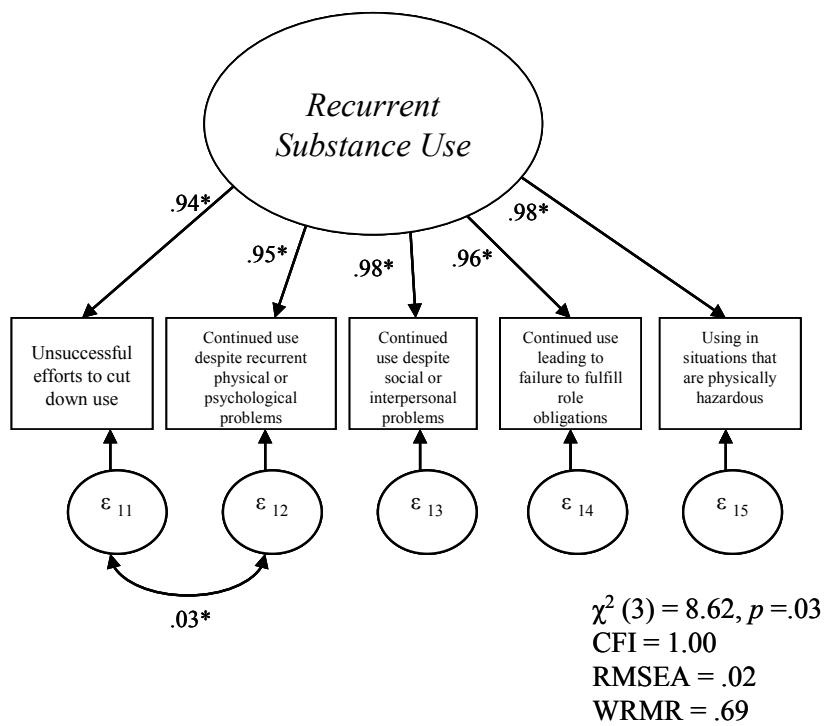
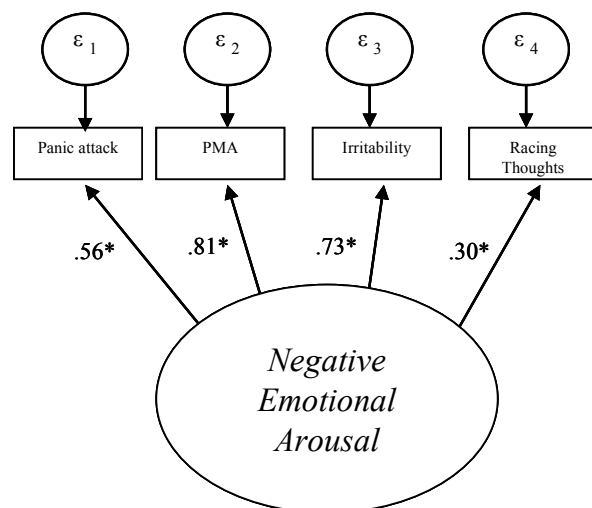

Figure 6



$\chi^2 (2) = 2.13, p = .34$
CFI = 1.00
RMSEA = .003
WRMR = 0.43

Figure 7

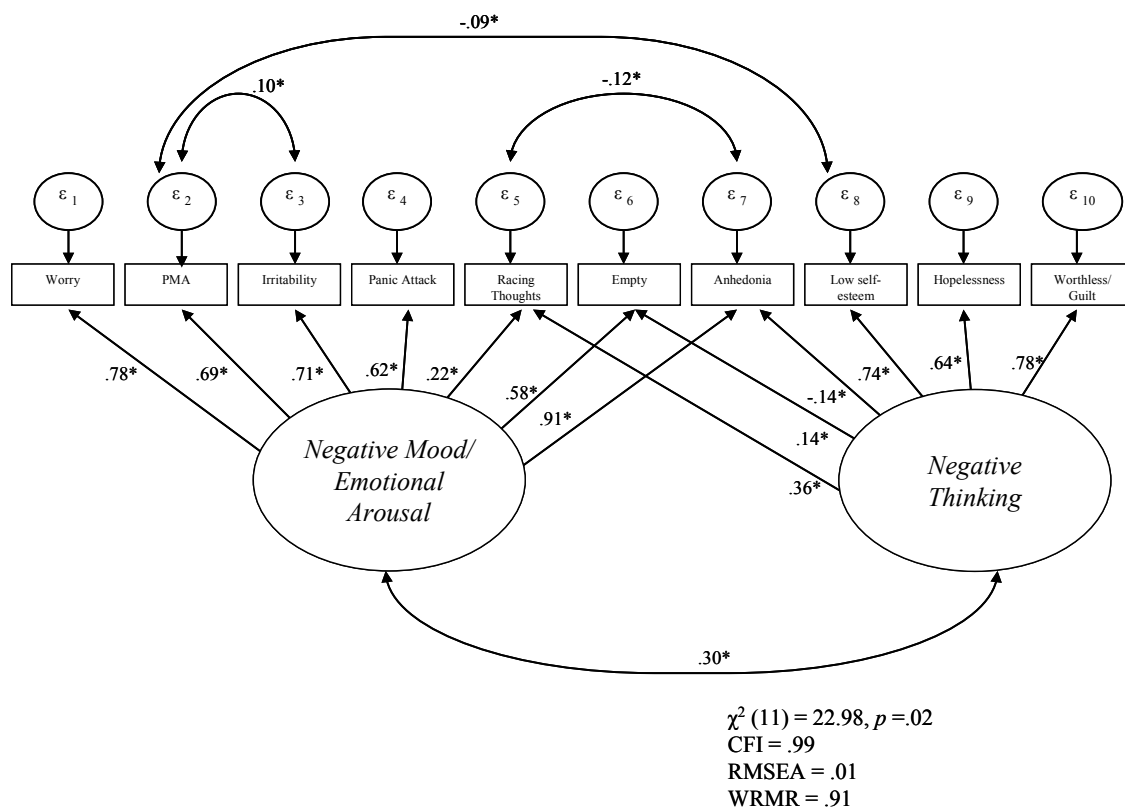

Figure 8

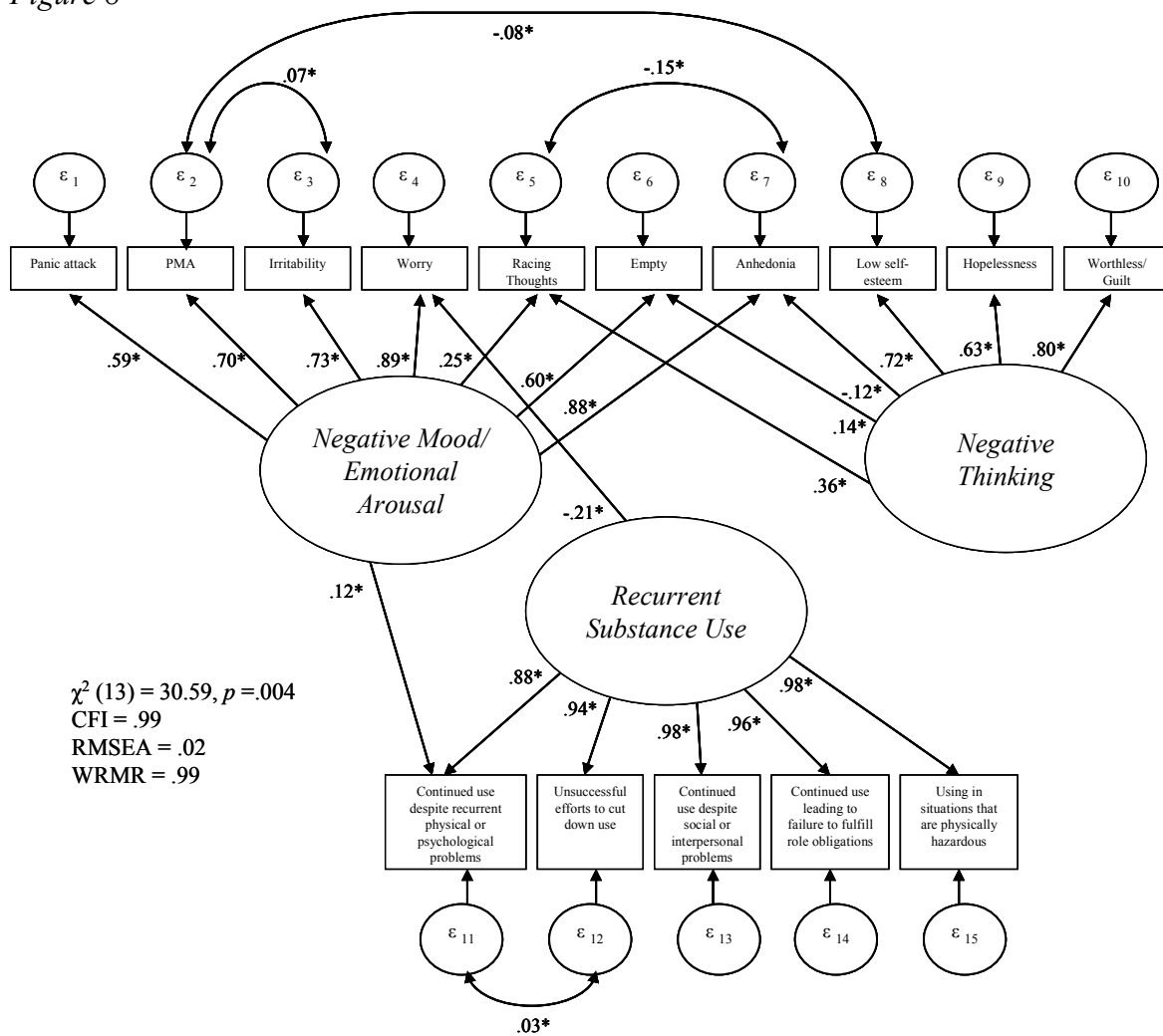
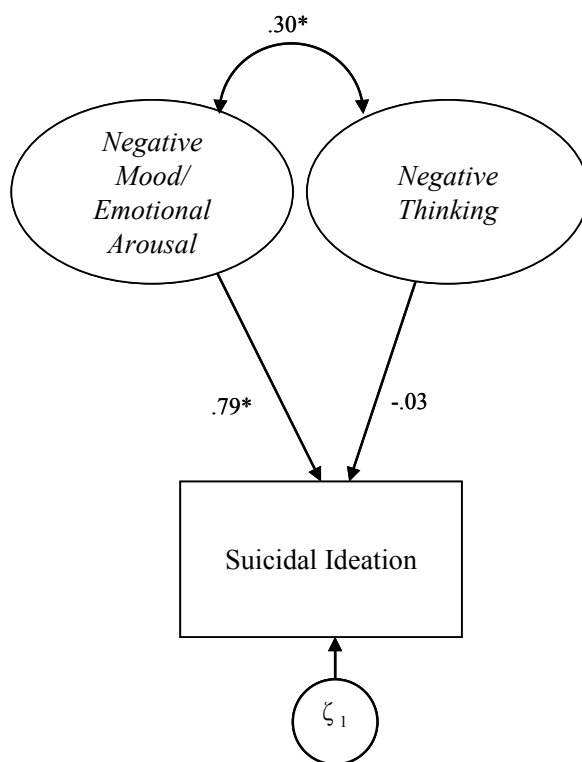

Figure 9



$\chi^2 (11) = 26.07, p = .006$
CFI = .99
RMSEA = .02
WRMR = .92

Figure 10

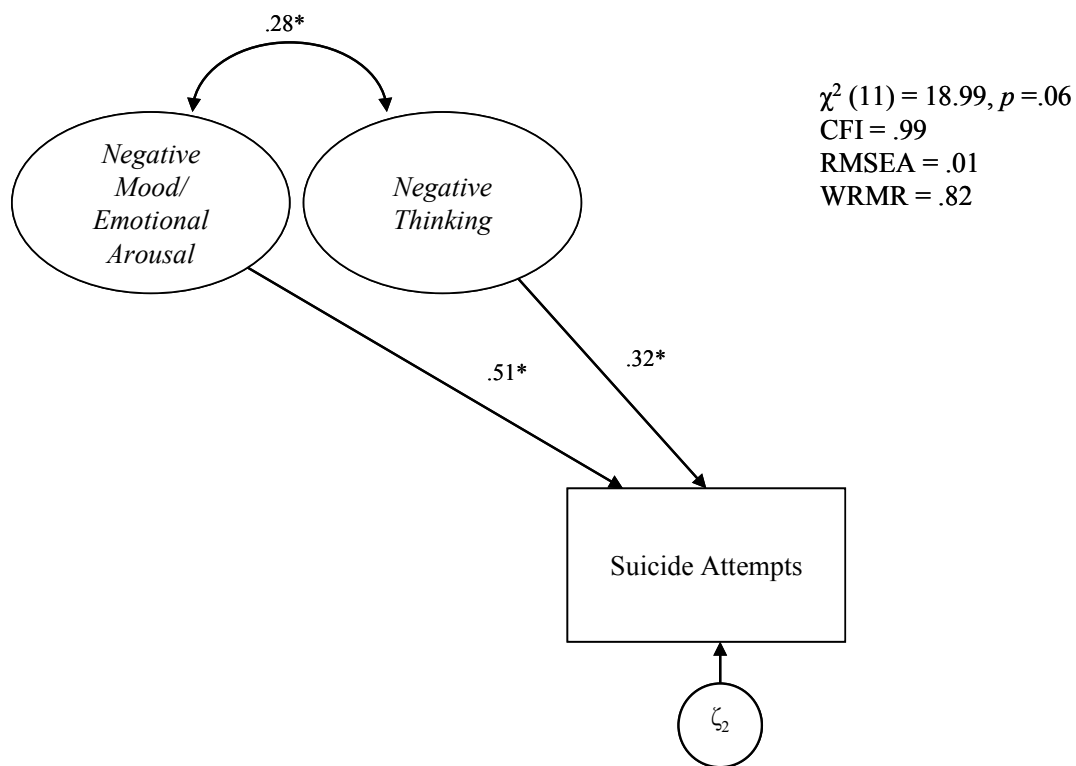

Figure 11

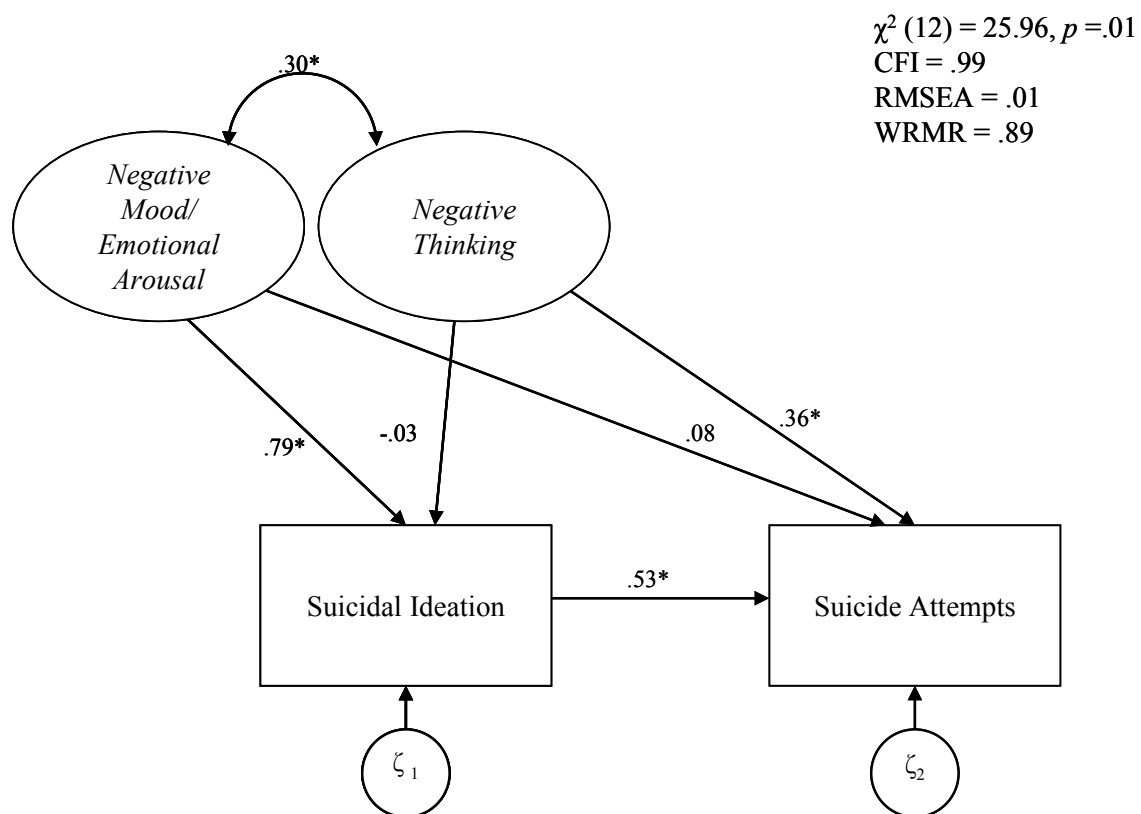

Figure 12

