

**PURDUE UNIVERSITY
GRADUATE SCHOOL
Thesis/Dissertation Acceptance**

This is to certify that the thesis/dissertation prepared

By Arash Edalatnoor

Entitled

ENERGY OPTIMIZATION OF AIR HANDLING UNIT USING CO2 DATA AND COIL PERFORMANCE

For the degree of Master of Science in Mechanical Engineering

Is approved by the final examining committee:

Jie Chen

Chair

Ali Razban

Co-chair

David Goodman

Co-chair

To the best of my knowledge and as understood by the student in the Thesis/Dissertation Agreement, Publication Delay, and Certification Disclaimer (Graduate School Form 32), this thesis/dissertation adheres to the provisions of Purdue University's "Policy of Integrity in Research" and the use of copyright material.

Approved by Major Professor(s): Ali Razban and Jie Chen

Approved by: Sohel Anwar

Head of the Departmental Graduate Program

02 / 25 / 2016

Date

ENERGY OPTIMIZATION OF AIR HANDLING UNIT USING CO_2 DATA AND
COIL PERFORMANCE

A Thesis

Submitted to the Faculty

of

Purdue University

by

Arash Edalatnoor

In Partial Fulfillment of the

Requirements for the Degree

of

Master of Science in Mechanical Engineering

May 2016

Purdue University

Indianapolis, Indiana

I would like to dedicate this thesis to my parents and my brother Amin for their
always love and support.

ACKNOWLEDGMENTS

I would like to express my sincere gratitude to my thesis advisor, Dr. Jie Chen, for the continuous support of my Masters study and research that helped me to get an incredibly valuable and professional experience in order to achieve a career growth within the field of mechanical and energy engineering.

I would like to also acknowledge my co- advisor, Dr. Ali Razban, for helping me to find useful resources for the study and providing leading instructional discussions without which this work could not be accomplished.

Also, I would like to thank Dr. David Goodman as my advisory committee for his help, mentorship, and friendship during my master studies and work on the thesis. Dr. Goodman provided a lot of great suggestions, guidance, and resources during my graduate studies and also the thesis research.

I would particularly like to thank on-campus personnel, Mr. Robert Meagher and Mr. Tom Pannington, for expressing interest in my thesis topic and sharing their valuable knowledge thorough my work on the research.

I also thank Anastasia Khudoyarova for not only providing support and friendship that I needed, but also helping me with the proofreading, editing, and technical writing portions of this thesis.

Last but not least I would like to thank all industrial assessment center members and engineers, specially my good friend Amin Amini, for their help and collaboration along this challenging research work.

TABLE OF CONTENTS

	Page
LIST OF TABLES	vii
LIST OF FIGURES	viii
ABBREVIATIONS	xi
ABSTRACT	xii
1 INTRODUCTION	1
1.1 Problem Statement	1
1.2 Previous Work	2
1.2.1 Modeling Approaches	2
1.2.2 Modeling Approaches with Energy Efficiency Focus	4
1.2.3 Air Handling Units Simulation Tools	6
1.2.4 Control Strategies	10
1.3 Objectives	11
1.4 Thesis Information Order	12
2 MODELING AND METHODS	14
2.1 Goal and Targets	14
2.2 What is Air Handling Unit?	16
2.2.1 Air Handling Unit Components	19
2.2.2 AHU Energy Usage	21
2.3 Modeling and Parameter Selection	21
2.3.1 Dry/Wet Coil Method	24
2.3.2 Enthalpy Based Effectiveness	27
2.4 Demand Control Ventilation CO_2 Based	28
2.5 Design of Experiment	29
2.6 Statistical Analysis	29

	Page
2.6.1	Moving Average Method 30
2.6.2	Model Deviations 34
3	SENSORS AND DATA COLLECTION 35
3.1	Experiment Goals 35
3.2	Test Facility 35
3.3	Floor Layout 35
3.4	Current AHU Design Specifications 36
3.5	VAV Terminal Unit Specifications 36
3.6	Building Automation System 36
3.6.1	AHU List of System Inputs 39
3.6.2	Sensor Types 40
3.6.3	Sensor Locations 40
3.7	Wireless Data Receiver 41
3.8	MODBUS Network Connection 45
3.9	AHU Sequence of Operation 47
4	THERMODYNAMIC AND MATHEMATICAL MODELING 50
4.1	Number of Transferred Units 51
4.2	Chilled Water Model 53
4.3	Internal Flow Model 55
4.4	Fouling and Conduction Resistance Model 56
4.5	Heat Exchanger Model 57
4.6	Cooling Coil Model 58
4.7	Pre-heat Coil Model 59
4.8	Coil Performance Model 59
4.8.1	Dry Coil Model 60
4.8.2	Wet Coil Model 60
4.8.3	Enthalpy Based Effectiveness 62
5	POWER OUTPUT CONTROLLER 65

	Page
5.1 Fuzzy Logic Controller	65
5.2 Membership Functions	66
5.3 Simulink Control Blocks	67
6 MODELLING RESULTS AND VALIDATIONS	69
6.1 AHU Model Validation	69
6.1.1 Dry Wet Coil Model Validation	70
6.1.2 Enthalpy Based Effectiveness Model Validation	73
6.1.3 Heat Transfer Comparison Validation	75
6.2 Sensor Faults and Accuracy Research	79
6.3 Ventilation Energy Model Validation	84
6.3.1 Fan Discrete ON/OFF Output Method	87
6.4 Fan Continues Output (Controller) Method	89
7 CONTROL STRATEGY OPTIMIZATION RESULTS	95
7.1 Discrete Fan Output Energy Reductions (ON/OFF)	95
7.2 Continuous Fan Output Energy Reductions (Fuzzy Logic)	96
7.3 Potential Energy Savings	98
8 CONCLUSIONS AND RECOMMENDATIONS	101
8.1 Conclusion for Air Handling Unit Modeling	101
8.2 Conclusion for Fan Power Controller	102
8.3 Recommendations for Future	102
8.3.1 Control Implementations	102
8.3.2 Powerful and Faster Wireless Communication System	102
LIST OF REFERENCES	103

LIST OF TABLES

Table	Page
3.1 AHU Design Specifications	37
3.2 VAV terminal unit specifications	38
3.3 AHU I/O List	43
3.4 Sensor types	44
6.1 Description of data sets	70
6.2 Error difference between two models	79
6.3 Normal CO_2 levels	85
6.4 CO_2 data collection	85
6.5 Input membership actions	91
6.6 Input membership actions	92
7.1 Energy reduction data collection	99
7.2 Energy reduction comparison ON/OFF and fuzzy logic controller . . .	100

LIST OF FIGURES

Figure	Page
1.1 Building energy usage in US [1]	1
1.2 Different modeling approaches [7]	4
1.3 Air handling unit, mixing box air flow simulation example. (Courtesy of Comsol CFD)	8
1.4 Energy plus simulation chart (Chart from NREL EnergyPlus)	9
1.5 Modeling and simulation flow chart	10
2.1 Methodology flowchart	16
2.2 Typical air handling unit system [27]	17
2.3 AHU coil units	18
2.4 AHU schematic diagram	19
2.5 Single duct VAV box (Courtesy of Johnson Control, Inc)	20
2.6 Dual duct VAV box (Courtesy of Johnson Control, Inc)	21
2.7 Typical centrifugal fan	22
2.8 Modeling focus in AHU	22
2.9 Heating and cooling coils Input/Outputs heat exchanger in AHU	23
2.10 Condensation on the coils [28]	24
2.11 Psychometric chart (Carrier)	25
2.12 Dry and wet coil method dehumidification process [28]	26
2.13 Actual air heat exchange process [28]	27
2.14 Enthalpy based effectiveness air heat exchange process [28]	28
2.15 Moving average method	30
2.16 Actual modeling results	32
2.17 Modeling results using moving average method	33
3.1 Facility floor layout	36

Figure	Page
3.2 Example of current building network (Wikipedia)	39
3.3 Sensor locations of the AHU (Metasys Johnson Conrtol)	40
3.4 CO ₂ sensor and FFD in hallway.	41
3.5 CO ₂ sensor and FFD in lab ET010.	42
3.6 CO ₂ sensor and FFD in lab ET019.	45
3.7 MODBUS network	46
3.8 PAN coordinator	46
3.9 Example of sensors attached to FFD	47
3.10 AHU flow diagram (Provided by Johnson Control)	49
4.1 Main energy consumers	51
4.2 Counter flow heat exchanger example no mass transfer [33]	53
4.3 Flow chart for identification model inputs and outputs.	54
4.4 Internal flow model Input/Outputs	56
4.5 Compact heat exchanger model Input/Outputs	58
4.6 Enthalpy based effectiveness air path assumption [33]	63
5.1 Current fuzzy logic controller	66
5.2 Fuzzy logic membership functions	67
5.3 Example of Simulink blocks	68
6.1 Dry wet coil method heat exchange comparison	71
6.2 Inlet air relative humidity	72
6.3 Enthalpy based effectiveness method comparison	74
6.4 Correlation between the trends for sub models (heat exchanger)	75
6.5 Correlation between heat exchange values and model comparison	76
6.6 Error between two models	77
6.7 Inlet air humidity	78
6.8 Comparison of two models in various relative humidity and inlet temper- ature values [33]	79
6.9 Outside air temperature sensor data	80

Figure	Page
6.10 Outside air temperature Indianapolis airport data [38]	81
6.11 Outside CFM sensor	83
6.12 Air ventilation inside building [39]	84
6.13 CO_2 values for the week of data collection in the test building	86
6.14 CO_2 histogram for ppm values during week of data.	87
6.15 Fan model for corresponding comfort air levels	89
6.16 Fuzzy logic controller input membership functions	90
6.17 Fuzzy logic controller output membership functions	91
6.18 Rule view for fuzzy interface system 448ppm ex (Simulink)	92
6.19 Rule view for fuzzy interface system 602ppm ex (Simulink)	93
6.20 Rule view for fuzzy interface system 843ppm ex (Simulink)	93
6.21 Fuzzy logic controller continuous correlation between Inputs/Outputs .	94
7.1 On/Off method modeling	96
7.2 Simulink scope input CO2 data (Simulink)	97
7.3 Simulink scope output power (Simulink)	98
7.4 Two controlling methods comparison	99

ABBREVIATIONS

V	Voltage
I	Current
R	Resistance
Q	Heat transfer rate
\dot{x}	Mass flow rate of a fluid
C_p	Specific heat
T	Temperature
ρ	Density
C	Flow rate
β	Fan % speed
α	Max coil capacity flow rate
\dot{q}	Theoretical flow rate through the coil
h	Specific enthalpy
ω	Relative humidity
P	Final parameter
T_x	Initial twelve bit number

ABSTRACT

Edalatnoor, Arash. M.S.M.E., Purdue University, May 2016. Energy Optimization of Air Handling Unit Using CO_2 Data and Coil Performance. Major Professors: Ali Razban and Jie Chen.

Air handling unit systems are the series of mechanical systems that regulate and circulate the air through the ducts inside the buildings. In a commercial setting, air handling units accounted for more than 50% of the total energy cost of the building in 2013. To make the system more energy efficient and reduce amount of CO_2 gases and energy waste, it is very important for building energy management systems to have an accurate model to help predict and optimize the energy usage and eliminate the energy waste. In this work, two models are described to focus on the energy usage for heating/cooling coils as well as fans for the air handling unit. Enthalpy based effectiveness and Dry Wet coil methods were identified and compared for the system performance. Two different types of control systems were modeled for this research and the results are shown based on occupancy reflected by the collected CO_2 data. Discrete On/Off and fuzzy logic controller techniques were simulated using Simulink Matlab software and compared based on energy reduction and system performance. Air handling unit located in the basement of one campus building is used for the test case of this study. The data for model inputs is collected wirelessly from the building using fully function device (FFD) and pan coordinator to send/receive the data wirelessly. The air handling unit modeling also is done using Engineering Equation Solver EES Software for the coils and AHU subsystems. Current building management system Metasys software was used to get additional data as model inputs. Moving Average technique was utilized to make the model results more readable and less noisy. Simulation results show that in humid regions

where there is more than 45% of relative humidity, the dry wet coil method is the effective way to provide more accurate details of the heat transfer and energy usage of the air handling unit comparing to the other method enthalpy based effectiveness. Also fuzzy logic controller results show that 62% of the current return fan energy can be reduced weekly using this method without sacrificing the occupant comfort level comparing to the ON/OFF method. Air quality can be optimized inside the building using fuzzy logic controller. At the same time system performance can be increased by taking the appropriate steps to prevent the loss of static pressure in the ducts. The implementation of the method developed in this study will improve the energy efficiency of the AHU.

1. INTRODUCTION

1.1 Problem Statement

Nowadays, engineers are focusing on preserving the environment by performing advanced research and experiments in the field of energy efficiency. Researches have shown buildings consume around 41% of total energy and 73% of electricity portion of energy generated in the US. [1] (Figure 1.1 shows the overall energy usage by buildings in the US also the amount HVAC energy usage for buildings). On the other hand energy efficient and smart buildings seem to be the future of architectural designs. Many researches have been done to find and achieve a tradeoff level between overall energy consumptions and also occupant comfort level in buildings. [2] Lack of accuracy in number of occupants prediction and energy models have caused a large amount of energy waste in the buildings. Indoor air temperature, air quality, and indoor illumination are three main factors considered as comfortable level in the buildings. [2, 3]

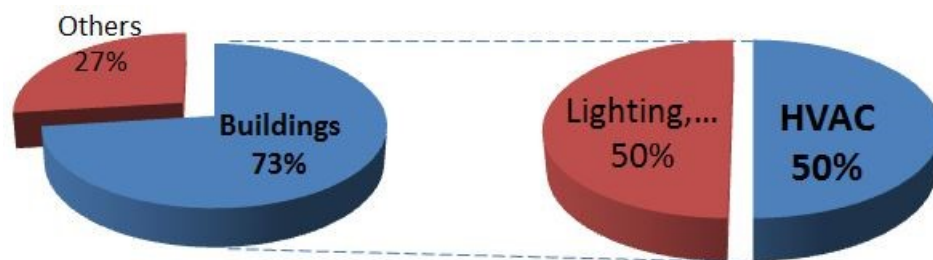

Fig. 1.1. Building energy usage in US [1]

Considering overall amount of energy usage by buildings and also the importance of comfortable air level in buildings for occupants, it is very important to come up

with a best design and modelling in air handling units (AHU) for the buildings. In order to improve the performance of Air Handling Units, an accurate model should be built that can predict the energy usage of the building at the same time provide a good system performance for AHU. This thesis is intended to develop such models for improving energy efficiency of AHU through simulations.

1.2 Previous Work

1.2.1 Modeling Approaches

Many studies have been done on the modeling and performance of AHU in the past. The vast majority of buildings have been using on-board sensors and software to monitor the general building performance. For example, they collect small amount of data and conduct a basic analysis on system performance over a period of time. Most of these models have assumptions based on first and second law of thermodynamics. These models often can be a very useful and quick solution to efficiency but they are not necessarily optimal design for the building AHU system. The majority of the models is not comprehensive and only provides quick solutions for each part of the system, which in overall may not improve the system performance much. [4]

There have been also different approaches in order to get the model behaviors for different HVAC components. One of the methods for example is focused on mathematical modeling of components. This method uses a different order polynomial results and representations to get the best fit and minimum modeling error for each component. Modeling in these cases is mostly based on system inputs and outputs without focusing on meaning of the system. When the data is taken from the outside of the fitted data range, it can lead to an inaccurate results. [5] Another method uses a complete mechanistic model of the system, which makes it very hard to adopt the model to different systems and buildings. Also, this detailed information is not always easy to find within the system components. There have been other researches of semi-mechanistic modeling technique, which ended up with better results on small

air conditioning systems. However, these models were not able to adopt easily to more complex systems, such as whole air handling units. [5] Also, many different control techniques have been used in different researches, such as Model Predictive Control, Evolutionary Algorithm, Evolutionary Programming, and PID controllers. These control were mostly used to regulate the temperature inside the house and keep the temperature below/above the user limits. [6, 7] However, most of these models do not completely cover all climate conditions and do not provide a general solution for bigger buildings. Therefore, the listed models can only be adopted to specific systems and are not robust enough to improve performance on different systems.

On making accurate models, other researchers used data driven approach, white box (knowing details) and also combination of non-physical and physical methods. In general, data driven approach uses the data which was collected in different conditions and then again as mentioned in [5] it uses statistical methods, such as linear regression and best data fit to find the rules and relationship for the air handling unit. These models are quick and simple approach, but not necessarily an accurate one. Because once the data falls out of the fitted line then results can be completely inaccurate. Also this approach is known as fault detection method that uses the input and output of the system. It calculates the error of the system and uses it to make the model more accurate and robust. [6]

Also, white box model has the details of mechanical system that is called Fully Mechanistic Modeling. This method of modeling makes it very hard to measure and find all the system parameters. Most of the time this parameters are not available and on the other hand it is very hard to adapt them with any new system or air-handling units. Also this method of the system modeling is an opposite what was explained in black box modeling, since black box modeling is only based on the details of mechanical system. Governing equations and systems behavior have been investigated using white box method and are described in different research materials. Figure 1.2 shows three general modeling approaches. [7]

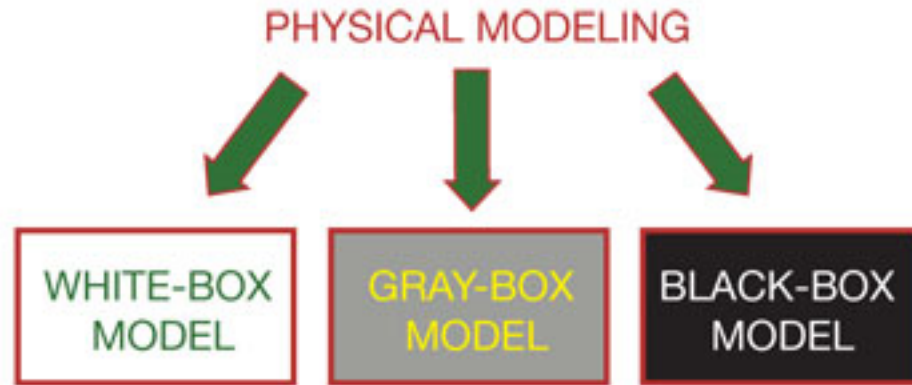

Fig. 1.2. Different modeling approaches [7]

Grey box is also called semi-mechanistic model. This method uses some details of the mechanical model and governing equations. Using these equations and inputs for the model this method calculates the output of the system. This method can conclude more robust results since it can adapt easier to different scenarios. The measurements can always be used as a feedback for the system and make the model more accurate or more compatible with different conditions. Many researches have been done using this method and validating the prediction of the model. Many HVAC systems have been using this method to predict their systems behavior. This method has advantages over white box and black box modeling mostly because of robustness and compatibility with different conditions. Also next section will focus more on previous work which have been done to make AHU more energy efficient. [8]

1.2.2 Modeling Approaches with Energy Efficiency Focus

In general, researches about energy performance in buildings started in the 1970s. With the rise of prices in oil and gas industries many nations started to look for new ways in using energy sources. Many energy protocols and regulations come in to place from government, which mainly focuses on energy efficiency and energy performance.

Many of these regulations have limitations of trustworthy benchmarking data since they do not provide detailed energy cost calculations. For example, ASHRAE in 2007 started to release standardized procedures for energy efficiency. These methods usually provide measuring and comparing solutions rather than detailed information since mentioned modeling only uses set of rules comparing to the controlling models/software models. [9]

There were other studies in energy efficiency areas that are more involved with changing the building or system settings. For example, resetting or changing the static pressure set points in the building, which can end up to 5% energy savings [10]. Also, other strategies are focusing on the peak and off-peak hours to rest the chilled water temperature in off peak hours to reduce the cost of chilled water (Gidwani 1984). Studies such as replacing valves and variable speed drives will reduce the cost of equipment retrofits, have been done to perform more energy efficiency actions. Most of these studies only show specific ways of savings that can be implemented in unique cases. [10]

Study from Elleson (1933) was focusing on the cost of different subsystems in air handling units. This research is mainly comparing different designs on terminal units. Parallel and series terminal units have some advantages over each other. Parallel terminal units use less energy since there would be less fan energy required to run through the ducts comparing to series terminal units. In fact, Elleson result shows that parallel terminal units can save from 24% to 47% on fan energy consumption (because of less fan energy usage as stated before). This study can only be used for the seasonal solutions and it is mostly energy saving for the cold air. [11]

In the other research from 1986 done by Leslie and Mazzucchi, who argues two major approaches for better energy performance analysis in buildings. These two methods are forward and inverse modeling. Forward modeling is about predicting the behavior of the system using simulation tools on hourly, monthly, or yearly basis. Inverse modeling is mostly collecting the data history of the building and try to match them together at every time of the year. Inverse models are quick and effective

solutions, it also leads to better savings. Inverse model method was used in studies, such as Claridge et al. 1992, Haberl et al. 1998. In other words combined invers and forward modeling can be considered as grey box model as it was discussed earlier. [9]

Mentioned techniques and strategies may be able to improve the functionality of the whole air handling unit system. In many cases such techniques are specific to seasonal and partial solutions. Also some of these techniques are system specific and they are not robust enough to be easily adapted to other air handling units or in other buildings. More importantly, majority of the previously described works do not target the energy modeling based on the overall energy cost in buildings. This issue would be resolved in this study. This work would include modeling and analysis of AHU focusing on energy consumption in whole air handling unit. Based on energy consumption of most energy consuming subsystems, there would be more sufficient information to provide for users and show the consequences of their actions on total energy cost in the building.

1.2.3 Air Handling Units Simulation Tools

Nowadays, using computers and variety of available tools makes it easier for engineers to come up with more accurate designs and models for complex systems. Air handling units and HVAC systems have been under such attention that many companies started building automation tools. Commercial companies and also governmental agencies have presented different simulation tools on the market. One of the very common tools is DOE-2, which is free to use and many researches have used it in the past. This tool was developed by “JJH associates” and “Lawrence Berkeley National Laboratory” (LBNL). Also, this work was sponsored by US department of energy (DOE). Another tool is called eQUEST that comes from the same publishers and it is also free. eQuest has more friendly interface and is primarily used for buildings energy usage. The tool does not require a lot of training for an engineer but at the same time provides a high level output and results of modeling and energy

usage in general [12]. eQuest has mostly the details of system design while DOE-2 focuses on cost functions and simple outputs/inputs from the system. Same kind of analysis also can be done with other software, such as Trane. However, Tranes most focus is on HVAC in details but not the whole air handling unit. This software also helps engineers to compare building standards with major energy efficient certificates. Trane can calculate ventilation, air quality, and many other standards of the existing building with major standard organization such as American Society of Heating Refrigeration and Air Conditioning (ASHRAE) or LEED certifications from US Green Building Council. Figure 1.3 shows an example of simulation tool for AHU and air flow inside the duct and AHU mixing box. [13–15]

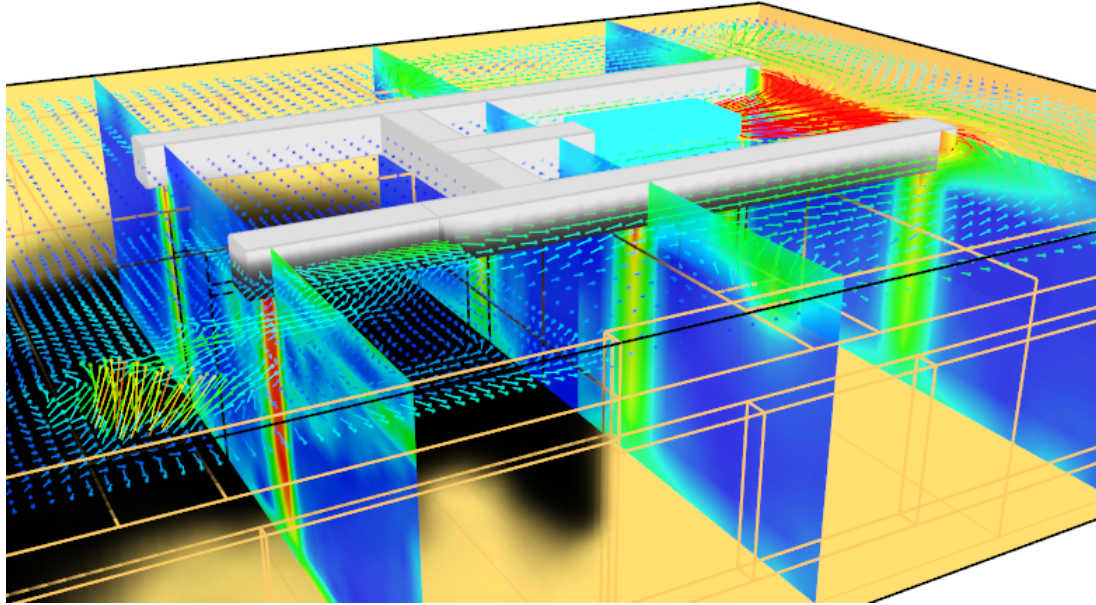

Fig. 1.3. Air handling unit, mixing box air flow simulation example.
(Courtesy of Comsol CFD)

Energyplus software is also one of highly used simulations tools for buildings. This software can be used by engineers, architects, and researchers for all air handling units. These mentioned software are highly dependent on building inputs, but neither of them have deeply focused on thermodynamic functionalities. Figure 1.4 from national renewable energy laboratory shows a software chart for device simulations, such as air handling unit.

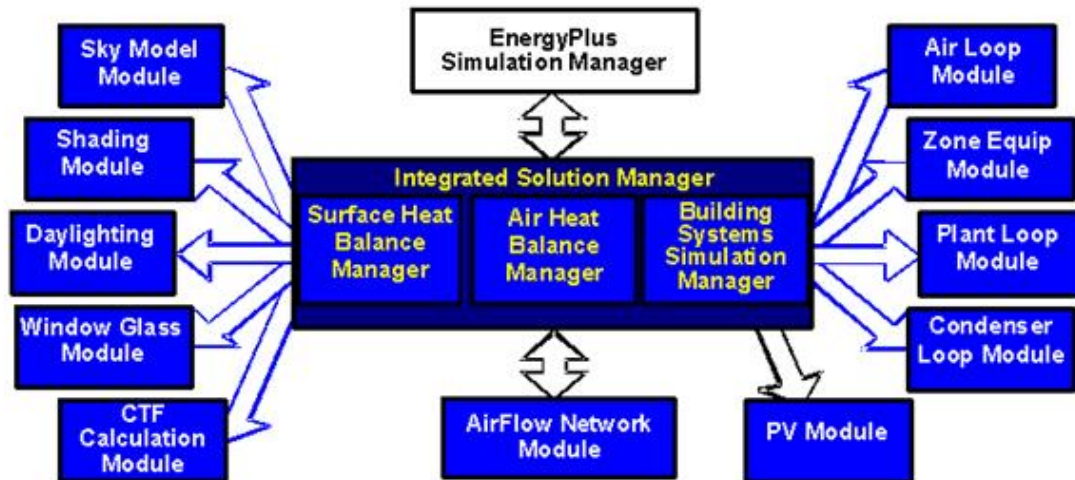

Fig. 1.4. Energy plus simulation chart (Chart from NREL EnergyPlus)

There are other coding and programming software like Matlab that can come very handy while using energy calculations for buildings. Engineering Equation Solver (EES) is another programming language which focuses on high level thermodynamic equations. One of the advances of this software that it has included all the thermodynamics libraries within the software, so it can automatically relate the characteristics of different parameters to their thermodynamics values. EES also generates plots and does check units. It has functionality of making Macro programming, therefore one can write all logic equations and use macro programming to run the whole code simultaneously calling for thermodynamic properties. [16]

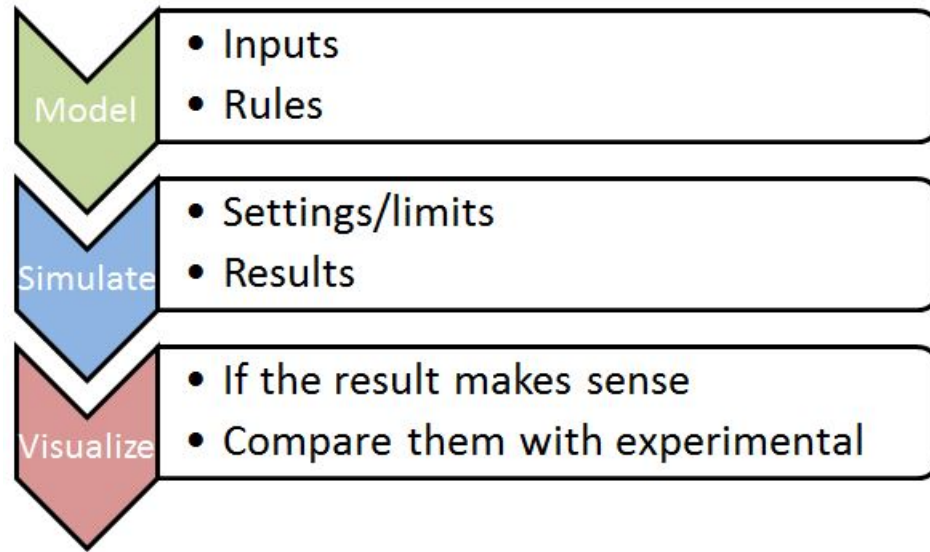

Fig. 1.5. Modeling and simulation flow chart

Figure 1.5 above shows the logic sequence of using simulation tools. The input of simulation tool like EEs can be a building air handling unit model. Using inputs and governing questions, this tool will provide us a visualization of the model. [17]

1.2.4 Control Strategies

There are different approaches in controlling the air handling unit systems. Different researches were performed on resetting sensor settings such as variable air volume boxes and discharge air temperatures. Dynamic modeling of air handling unit systems, which has been described in the following reference [18, 19] uses orientated modeling platform, named as Modelica-based. This model based only uses input and output of the system so it does not consider what is inside the modeling system. The optimization is done based on eliminating the error between input/output. Also, various type of controllers have been used the air handling units, such as proportional-integral-derivative (PID) loop feedback mechanism. PID controller has been used

mostly in black box models which uses only input and output of the system. Using constant gains in PID controller the model can predict the error of the system and finally updates system parameters such as supply temperature, fan speed and etc. Disadvantage of PID controllers is that the design parameters are constant and they cannot be adapted by every systems. It is good to use this type of control for subsystems of Air Handling Units but not as overall system modeling. Working with multiple input-outputs and more complicated systems make the PID controller very difficult to program. [20,21]

Most of air handling units work is based on different number of sequences. These sequences and controls can be adjusted by threshold for certain values. There are many sensors that send data to these controls. These sensors get tripped based on pre-defined threshold. Decoupling methods have been described in the following Ref [22]. Generally there are two types of static and dynamic decoupling controls. For example, static decouplers have constants and steady state process but since these values are fixed the control performance will not be satisfactory. In opposite way dynamic decouplers need more details in modeling but at the same time the output for these systems are more accurate and trustworthy. [23–25]

1.3 Objectives

The goal of this thesis is to make the air handling unit more efficient without scarificing the comfort level. If there is unnecessary energy waste in the system they would be addressed and removed while keeping the same or more advanced system performance. Achieving this goal and finding the unnecessary waste in the system would be accomplished by system software modeling and validation.

Making the correct modeling is performed by thermodynamic law, mathematical and logical equations. Meanwhile, there are statistical techniques applied to get rid of outliers and make the model more representable. Later in this study, different models

will be implemented on air handling unit. Data will be collected through the sensors in the building in order to interpret the model.

Simulation tools such as Matlab, Simulink, and Engineering Equation Solver have been used to make the model more accurate and validate it with existing experimental data. Coil performance has been analyzed and statistical analysis has been used to make the thermodynamic and mathematical models more compatible. Based on the experimental data, different models would be validated and different energy reductions and control strategies would be recommended. Two different coil performance modeling have been introduced and validated. Methods of energy reduction have been introduced using CO_2 data measurement and automation of demand ventilation for air handling unit. Fuzzy logic controller has been made to show the energy reduction of mechanical system and system performance improvement.

In the end, validated models have been compared in terms of total energy consumption, occupant comfort level, and system performance. Performance data will be followed by conclusions and discussions in the final section of this study.

1.4 Thesis Information Order

In the next chapter there will be information of modeling types which have been used in this work, the rationale for why these methods were chosen, also general information of air handling units, components and controls. There would be two different models explained along with the demand control validation method for energy savings on the air handling unit. Chapter 3 has included information on data collection, the type of sensors have been used, and where they were installed. The information on the test facility used was presented, which included associated specifications, location and etc. The important areas are the current configuration of air handling unit and automation system. The information regarding wireless receiver for sensors data and Modbus network in general will be explained afterwards.

Chapter 4 will include details of thermodynamic and mathematical modeling of air handling unit. Each individual part of air handling unit box will be explained in terms of thermodynamic equations. In this research specific type of controller has been used that will be explained in Chapter 5 and software associated with this modeling. Chapter 6 will present information about the results and validations of thermodynamic model for each individual method and part of air handling unit. There were different statistical methods, which have been used in this research, they are explained in Chapter 7. Results and comparison from the control is included in Chapter 8 and final conclusions and recommendation will be covered in Chapter 9.

2. MODELING AND METHODS

2.1 Goal and Targets

The ultimate goal of this thesis is to make the air handling unit more energy efficient and increase the system performance in terms of total energy consumption without sacrificing the occupant comfort level. This work has been done by using one of school campus buildings and implementing different sensors. These sensors are connected to a wireless network through the school network to ease the process of recording the data and using sensors as the inputs to the system/model. The wireless system also allows controlling the buildings energy usage from offsite locations using the sensor data information passed to the software model. Sensors location has been researched to get the ultimate data recording. Also the wireless devices have been researched so that it proves its good connectivity and accuracy during data transmission. Software coding has been done for data collection and software connections to the main server. CO_2 sensors also were placed to get the amount of air quality and required ventilation for the building.

There were different software used in this research for data collection and modeling purposes. Filezilla has been used to collect the data from sensors to the server. Metasys software from Johnson Control was used to visualize and temporary store the data. Matlab software has been used to make the mathematical and logical sequences for the data. Matlab Simulink was used to make the CO_2 simulations and power output controllers. Also Engineering Equation Solver (EES) has been used to make the thermodynamic model of air handling units. EES software was chosen mostly because of available built in thermodynamic charts and functions libraries within the software. The professional version 9 of EES was acquired for the research work within the school. There are multiple advantages for using EES system. This software

automatically re-orders the equations to get the fastest solution. There are over 1200 substances and built-in functions for different materials and thermodynamic properties. Another advantage of ESS software is Macro commands, which allows the user to write scripts. These scripts allow loops and other different functions, logics. Different software can be called through macro commands for example Excel file in order to modify and store the test results. [26]

Using software and making models for the system, results were compared to experimental data. Also different thermodynamic models were compared and discussed through this work. Data validation has been done by working on real time data from the system and Metasys software. Most important part of this work was working on data validation and tuning in the data to make the most accurate model. Errors between models have been discussed to get the accurate data validation.

Statistical analysis have been made to make the data more readable and useful for comparison, such as moving average method to low pass filter the data for avoiding sensors spikes and deviations between different models have been analyzed. In the end, CO_2 data was analyzed and a controller has been introduced to reduce the unnecessary energy consumption of the air handling unit. Figure 2.1 in explains the overall sequence of modeling and methods to perform energy savings strategies.

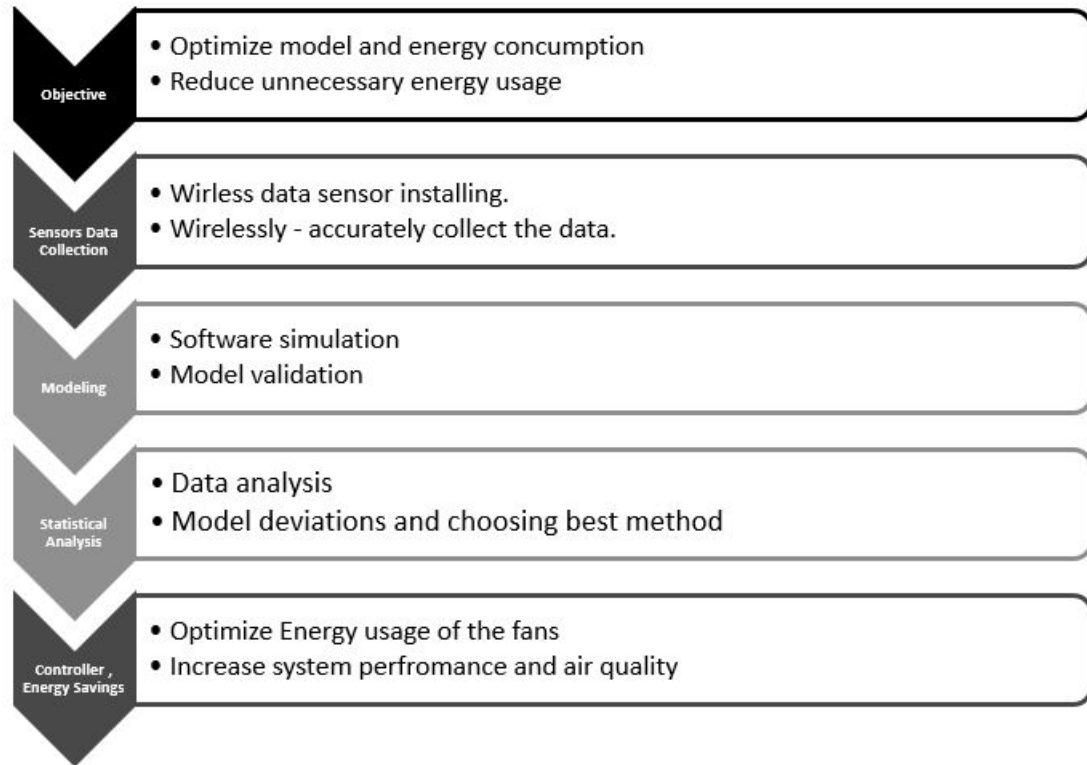

Fig. 2.1. Methodology flowchart

2.2 What is Air Handling Unit?

Air handling unit systems are the series of mechanical systems in order to regulate and circulate the air through the ducts inside the buildings. Air handling units include equipment such as fans, filters, dampers, different sensors, and coil that are inside the heating ventilation and air conditioning system (HVAC). Air handling units always have a main unit, which can be placed on roof of the building or inside the mechanical rooms for bigger buildings. Figure 2.2 shows a typical air handling unit system in medium size building, where yellow parts represent different components of air handling unit for this particular building.



Fig. 2.2. Typical air handling unit system [27]

In a typical air handling unit system there is a boiler for providing steam for heating purposes and also chilling water system for providing chilled water for cooling. In this research the facility is purchasing these two materials from the city. So in the test building the general system does not have boiler and chiller but these materials are being sent to the building from the city. Also the purpose of this thesis is more to focus on coil units and making an accurate model for it. Figure 2.3 shows a particular coil unit.

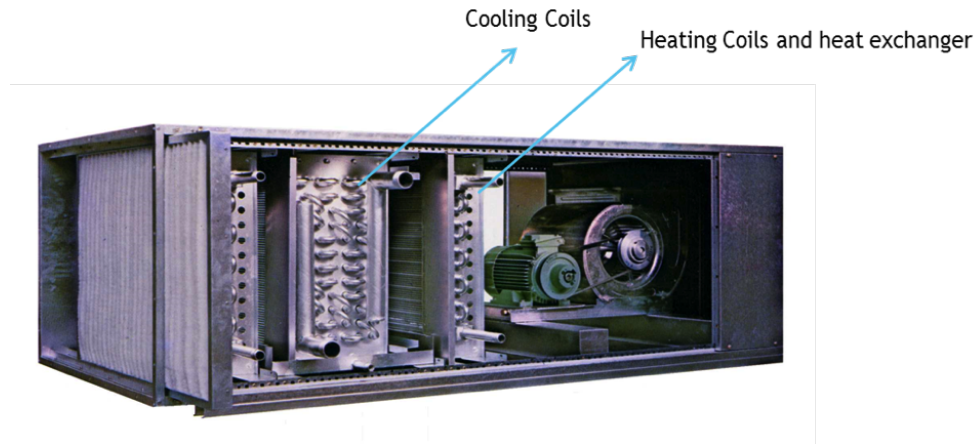

Fig. 2.3. AHU coil units

As its shown in Figure 2.3 cooling coil would pass chilled water and heating coil would pass steam so the air that is flowing can get certain amount of heat or removing heat. There are heat exchangers in which move air accordingly through the coils. From the very left in the Figure 2.3 the air flows in will get passed through the filter and enters in humidifiers. After that air hits the cooling and heating coils. On the right side there is a supply fan inside the unit which provides enough differential pressure in order to force the air through the unit.

Fresh outside air comes in to the system Figure 2.4 would enter the mixing box and pass through the coil units. Return air and Exhaust air are also shown in the figure. Dampers allow certain amount of return and outside air to get in though the system. Also there is a building automation system available to control all the commands and also monitor the data from the sensors inside the unit. In the following sections of this thesis there will be more information about the EMS or how energy management system works. Current energy management system from this air handling unit is Johnson control Metasys system.

2.2.1 Air Handling Unit Components

Current air handling unit includes parts shown in Figure 2.4. The simple picture of this air handling unit includes return fan, supply fan, dampers, heating, and cooling coil. At the end, supply air would be sent to variable air volume boxes where there are 36 VAV boxes existing in current test facility. Current VAV boxes as shown in Figure 2.5 which is a single duct variable air volume component.

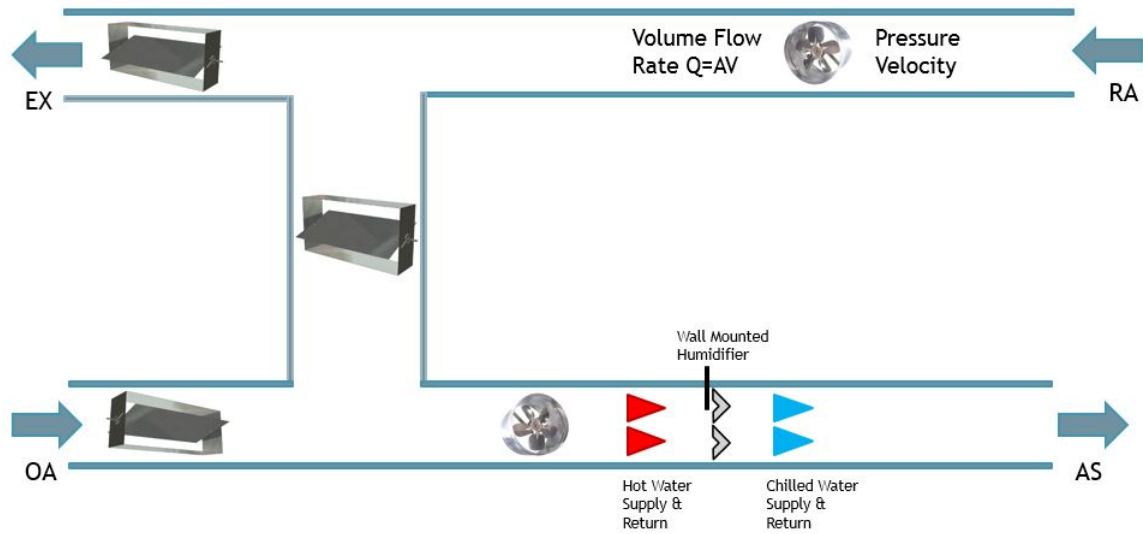

Fig. 2.4. AHU schematic diagram

Variable air volume boxes are part of air handling units that supply air flow with slightly variable air temperature to each zone. One of the advantages of using variable air volume boxes is that the control for each zone will be more precise, since each vav box has the ability to change the air temperature. There are different VAV box types available. Figure 2.5 shows a typical VAV box, which is also currently being used in this test building. This VAV box is referred as single duct VAV box.

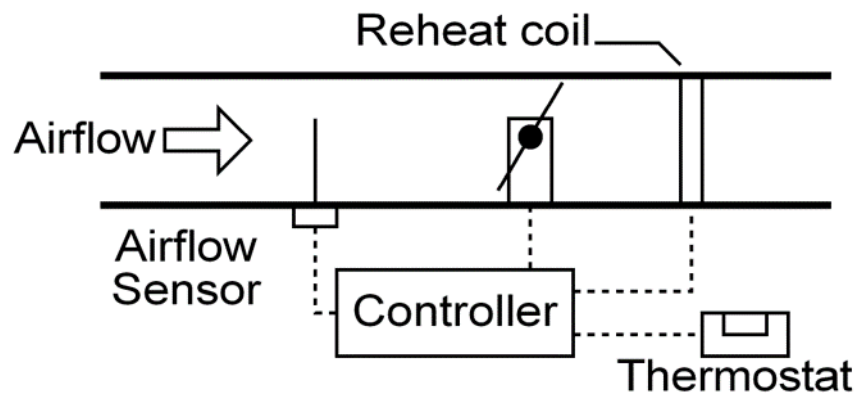

Fig. 2.5. Single duct VAV box (Courtesy of Johnson Control, Inc)

Figure 2.6 is showing other type of variable air volume box. The advantage of this VAV box is that the box has an extra fan that can provide more air to build enough fresh air for each zone.

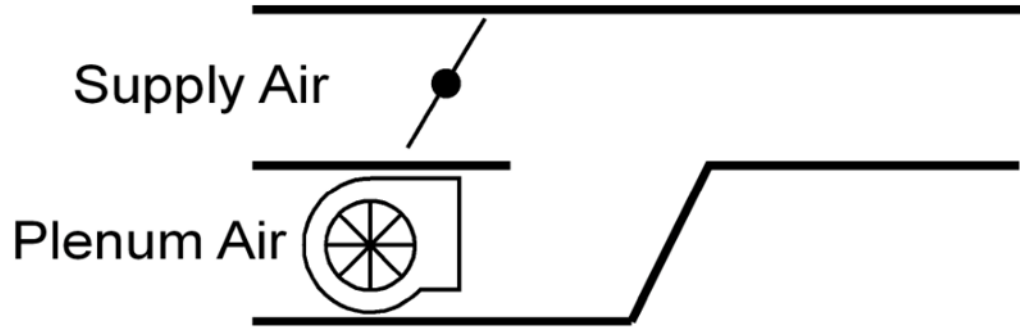

Fig. 2.6. Dual duct VAV box (Courtesy of Johnson Control, Inc)

2.2.2 AHU Energy Usage

This research mainly focuses on major energy usage components of air handling units. These parts, such as fans, use a lot of electricity power to keep the static pressure positive inside the ducts. Also heating and cooling coils are major energy consumers of AHU. This thesis provides detailed information on these parts and provides solutions on how to reduce energy usage and to peak best model for different conditions.

2.3 Modeling and Parameter Selection

Parameter selections in this work were mostly based on energy usage. Most of the energy in air handling units is being used by boiler and chillers. In our case the building is purchasing steam and chiller water from the city. Parameters also were selected based on how important is their role on energy consumption and occupant comfort level. One of the important subsystems that consumes a lot of energy and affects the CO_2 level, ventilation, and occupant comfort is the fan. Figure 2.7 shows a typical centrifugal fan which has been used in the air handling unit.

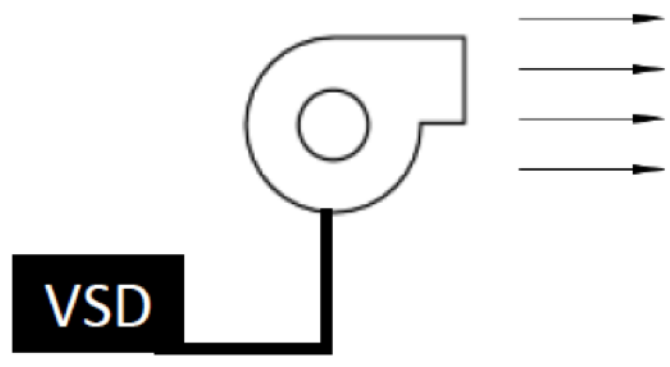

Fig. 2.7. Typical centrifugal fan

The inputs to this subsystem are air and electricity. Electricity is used as the energy to increase the static pressure and air flow inside the duct. Also VSD or variable speed drives are implemented in some of the fans in order to control the speed of the fan and air flow inside the duct. In the current air handling unit setup the supply fan has an active VSD.

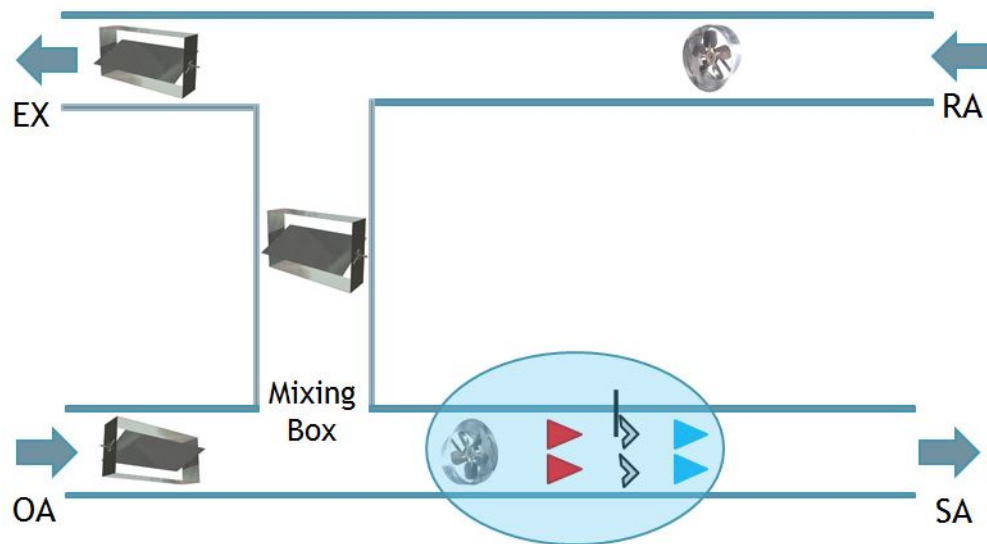

Fig. 2.8. Modeling focus in AHU

As it is shown on Figure 2.8 modeling in this thesis have been focused on the AHU unit, preheat, cooling coils, and the fan. Figure 2.9 also shows how the heat exchanger inside the air handling unit is setup. As it is shown on the figure the inputs to the system are obviously air from the duct, chilled water supply, and hot water or steam supply. The outputs of the heat exchanger are supply air, chilled water return, and hot water (steam) return.

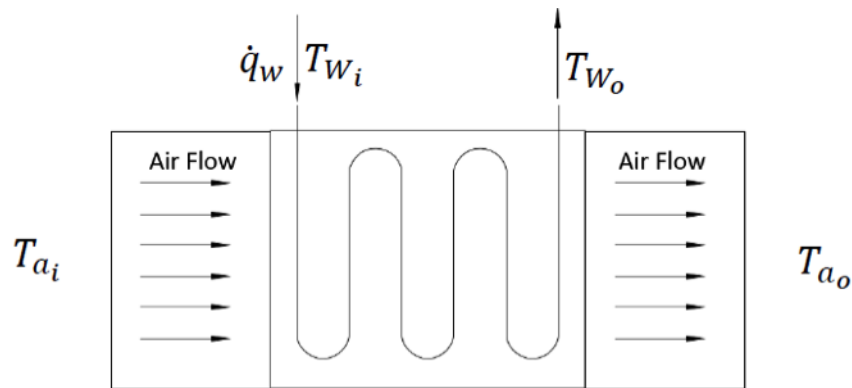

Fig. 2.9. Heating and cooling coils Input/Outputs heat exchanger in AHU

The more detailed information of system inputs/outputs is described on Figure 4.3 for AHU flow diagram. For better understanding on how these two are being used will help to make the usage more efficient and reduce the waste. On the other hand, fans use a lot of electricity/energy to keep the positive static pressure in the ducts. If fans are not working efficiently and are turned on without any reasons it will end up with a lot of energy waste. These items have been identified as most energy consumers inside the air handling unit. Both, model and results, will present how to avoid energy waste and make a better use of them later in this thesis.

2.3.1 Dry/Wet Coil Method

Cooling and heating coils are cross-flow heat exchangers in most common air handling units. In cross-flow heat exchangers heating and cooling is provided to the air from the steam and chilled water. Also dehumidification and humidification is done through these heat exchangers. For example, if the cold side and chilled water temperature is lower than the dew point of air, during the heat exchange water in the air starts to condensate. Therefore, there would be less moisture in the air.

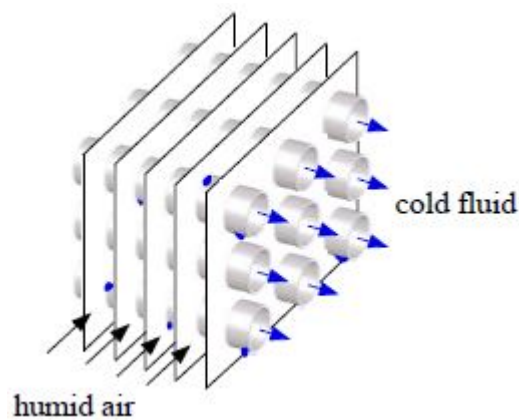

Fig. 2.10. Condensation on the coils [28]

To get the best results from the heat exchangers, it should have very thin layers and also large surface so it could exchange the maximum amount of heat. Most of the heat exchangers are made out of multiple tubes and rows versus finned coils in order to force the air between the cold and hot sides as shown on Figure 2.10.

As it was mentioned before in this research there were two methods discussed for air handling unit coils. The first method is called dry and wet method approach that basically divides the heat exchange between cold and hot to two different sections as dry and wet. Second method is also described based on Psychrometric chart and saturated line for air and water, which will be explained later. Psychrometric chart shows the physical and thermodynamic properties of gas-vapor mixtures (Figure 2.11).

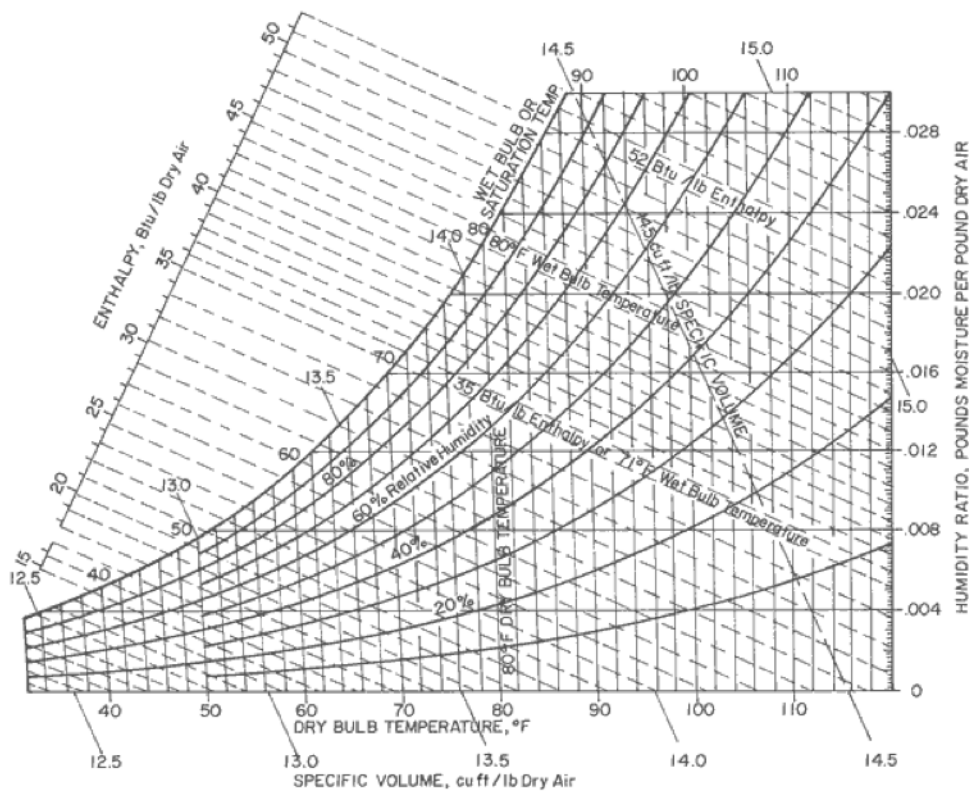

Fig. 2.11. Psychrometric chart (Carrier)

Dew points and saturation temperature are shown on figure above. Dew point is basically the temperature that water vapor reaches at the saturation level. From this point if heat is removed from air for it will condensate the amount of water in the air since it reached the saturation level. Also in this example the process of dry and wet coil methods can be shown on Psychrometric charts as well as in enthalpy based effectiveness method. In this specific example consider air enters the coil with temperature of 25 degrees Celsius and also leaves the coil with temperature of 7 degrees Celsius. If this condition happens in relative humidity of 42 percent then the path for dry and wet coil method can be shown below.

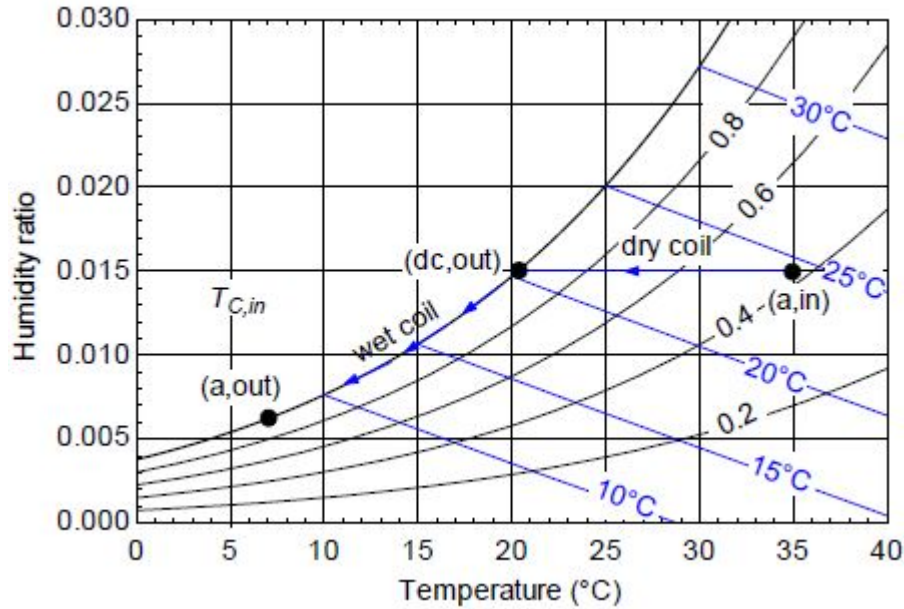

Fig. 2.12. Dry and wet coil method dehumidification process [28]

So, on Figure 2.12 as it is shown in dry coil part only the temperature of air reduces until it reaches the saturation line as it was discussed in psychrometric chart section. In the first part there won't be any dehumidification as in this method is assumed. Once the air gets to its dew point the dehumidification process starts and it will enter to the wet coil part. In first part during dry coil as its shown in Figure 2.12 the humidity ratio of air stays the same. As it enters the saturated line and wet coil part the dehumidification starts.

The wet coil analysis allows calculating two heat exchanger values for dry and wet coil approaches. The advantageous of this method is the amount of dehumidification can be specified in terms of heat exchange values. But also, when the air that enters in the coil does not have high humidity ratio, this method might not be accurate enough to calculate the dehumidification amount. This is the expected results and it will be more discussed in results and conclusions section.

2.3.2 Enthalpy Based Effectiveness

So in contrast with wet dry coil method enthalpy based on effectiveness assumes the coil is partially or fully wet, which means there is always dehumidification happening along the process. But in fact, the air that is closer to the fans and heat exchanger areas faces more heat transfer and dehumidification, but also some air may not touch the heat exchange areas and somehow skip it through the path.

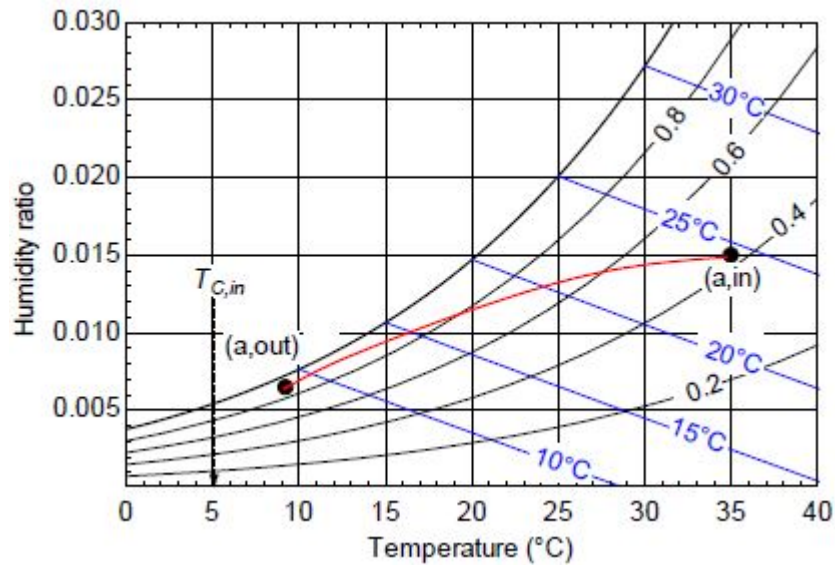

Fig. 2.13. Actual air heat exchange process [28]

Figure 2.13 shows in reality what would be the actual heat exchange process where there would be a smooth change of humidity ratio throughout the coils. But also in enthalpy based effectiveness its assumed that this heat exchange process if straight line of change in enthalpy values of the air so it does not consider the amount dehumidification and humidification as two separated regions.

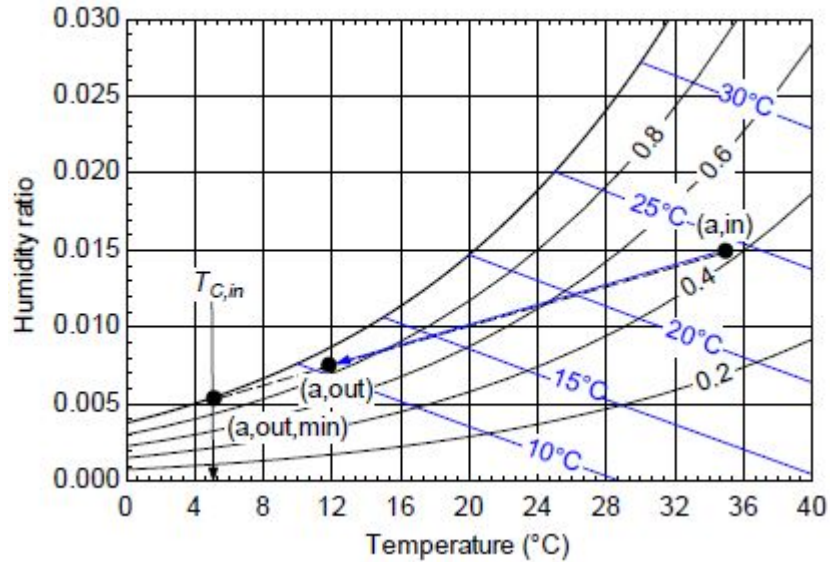

Fig. 2.14. Enthalpy based effectiveness air heat exchange process [28]

Figure above 2.14 shows how the enthalpy based effectiveness approach is based on air heat exchange process. Using energy balance equations the amount of total heat transfer and water vapor can be calculated.

2.4 Demand Control Ventilation CO_2 Based

Also another focus of this research is reducing energy consumption of the fans by calculations based on CO_2 . Since the indoor air quality is very dependent on the number of people inside the building and also more importantly is based on their activities. This method can give us accurate predictions of energy usage for the fans. Using this method we can also reduce energy waste by reducing unnecessary ventilation inside the building. Fresh air and good quality air is necessary inside the school buildings. So this research concentrates on calculating the required demand and power for the fans based on sensor data that have been mounted inside various locations in building to calculate CO_2 values.

2.5 Design of Experiment

Three main methods have been discussed to model the energy efficiency and energy consumption of the air handling unit subsystems in the building. This section explains what parameters and predictors have been used to validate the models. In the first two thermodynamic models the focus on the model validation was more on humidity ratio and inlet temperature as the main factors to compare the models. Inside the heat exchanger the main air properties that change significantly are temperature and humidity ratio, since humidification and temperature raise happens through the heating coil. This condition also applies in cooling coil where air reaches its saturated temperature and enters the de-humidification part. The purpose of this research is mostly focused on the energy cost aspect of modeling. So the result sections and models variation are discussed based on the amount of heat exchange in each model. Later on this heat exchange amount (or energy) can be transferred directly to cost depends on energy value in each region or city. The CO_2 modeling focus was mostly based on ppm values in the air for carbon dioxide. CO_2 numbers are the indicators of the amount of fresh air presented in the room, building or etc. So amount of ventilations needed in the building is calculated and compared based on different allowed CO_2 limits explained in Section 6.3 and specifically in Table 6.3.

2.6 Statistical Analysis

After working on models and getting results, it was decided to work on some data polishing. Not all the results were readable and reliable as (refer to figure actual modeling result), especially while working with all different units and different software. There is couple of different statistical analysis performed in this research, such as moving average method, histogram analysis, data deviation and comparison. Two major methods are explained below.

2.6.1 Moving Average Method

This analysis is basically a calculation in mathematics and physics used to show the general trend of the data sets. This method works based on the series of averages for different subgroups of the full main data sets. Moving average method is also a great tool on financial applications that allows users to see the trend change in the datasets. [29–31]

This research has used moving average method to smooth the data from the modeling and to get the trend of heat transfer calculations rather than just looking at the spikes and invalid single data points in the modeling.

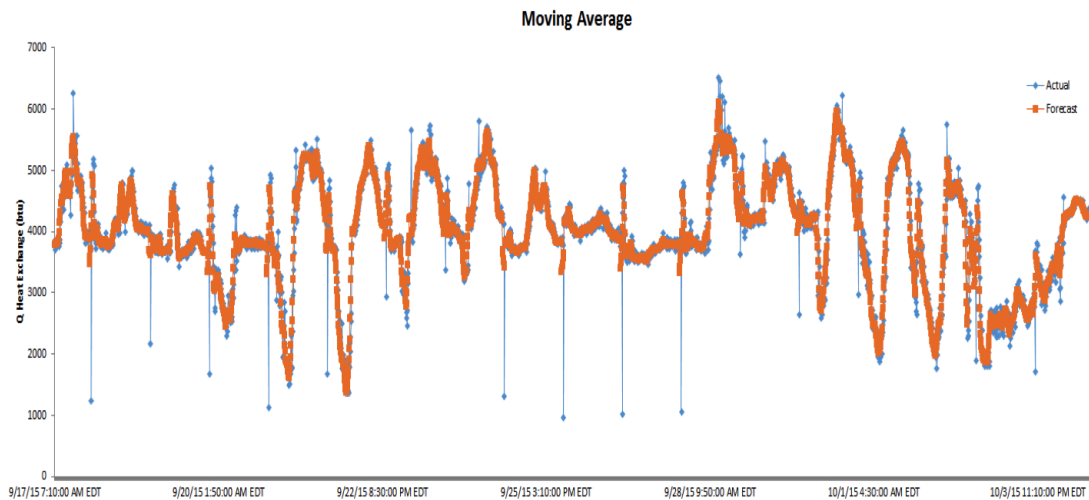

Fig. 2.15. Moving average method

For example, Figure 2.15 shows the difference between the actual datasets and forecast values for the data sets. In this case forecast data sets are consecutive average of 5 actual data points. In other words every 5 different data points were averaged and plotted as the forecast. In this way we can avoid extreme picks in the data set and as you can see the forecast shows more the actual trend of values. In this research this method was used to compare the trend of coil performance modeling on two

different methods. One is dry wet coil method and the other is enthalpy based effective. These two methods were compared with the actual experimental values using moving average method. Moving average method helped to focus more on the trend of modeling rather than details of spikes in this work. It was also useful for data comparison after performing moving average method since it smooths the data. Figure 2.16 shows the actual results from modeling. You can identify single invalid data points in this modeling that looks like spikes. By comparing Figures 2.16 and also 2.17 one can easily realize the advantages and improvements of using moving average method. Figure 2.16 includes a lot of data spikes and out of correct range data but Figure 2.17 provides smooth data graph and the overall trend.

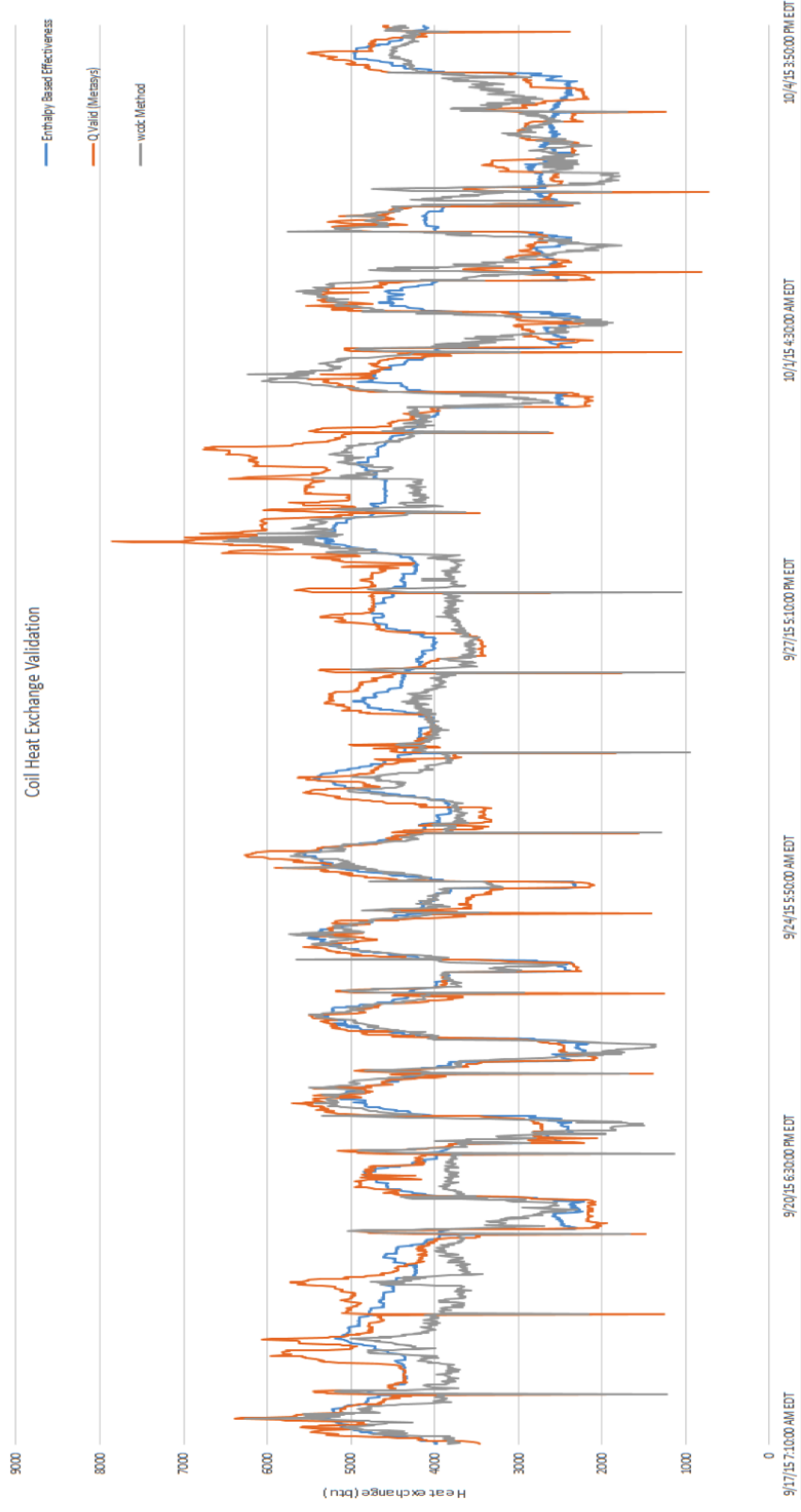

Fig. 2.16. Actual modeling results

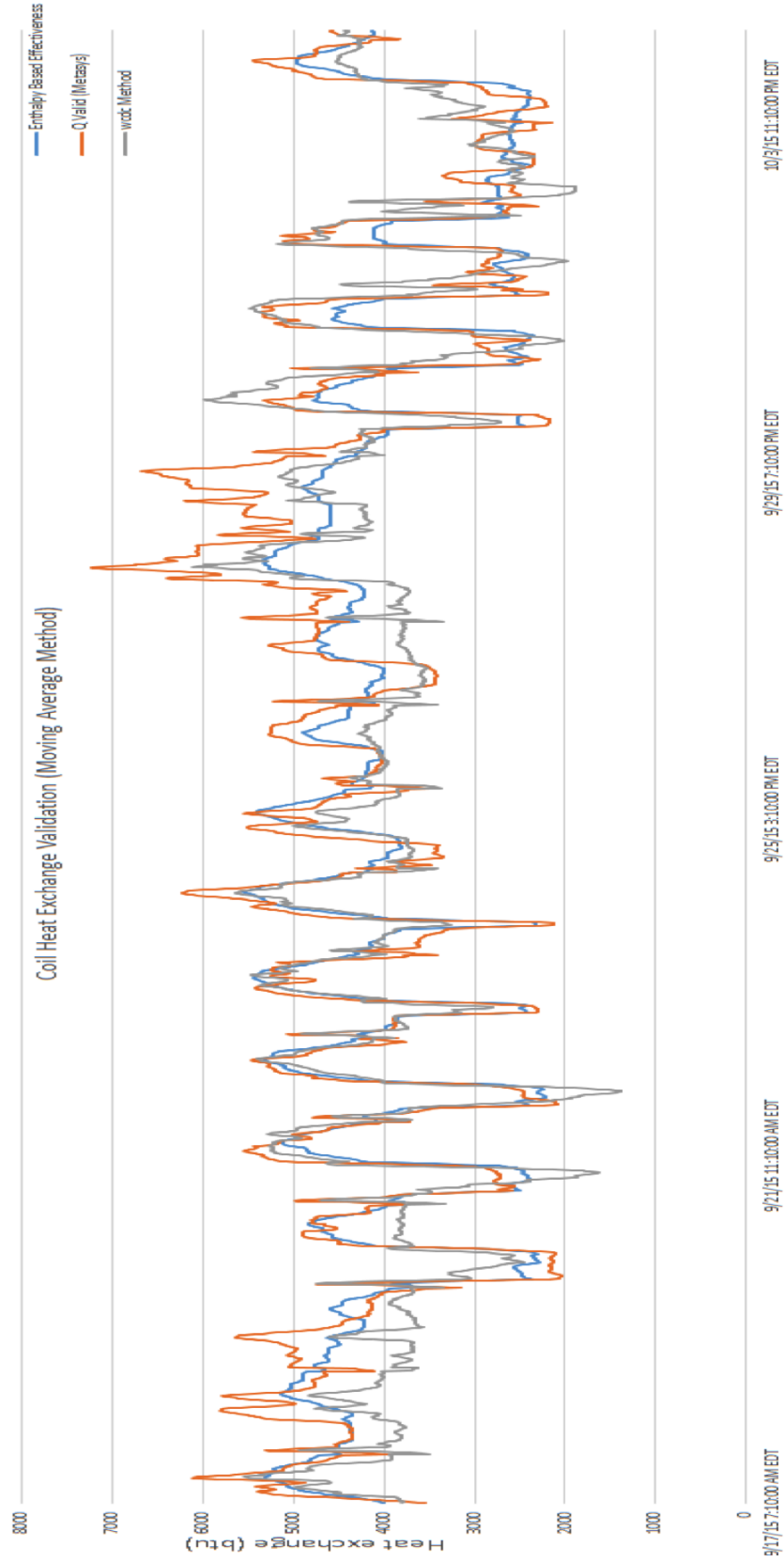

Fig. 2.17. Modeling results using moving average method

2.6.2 Model Deviations

Error was calculated between two models by using model deviations analysis. Deviation simply gives us the difference between two models. There are many tools that can help us performing this action for large datasets. The standard deviation tool in Excel gives an indication of how much data is spread out for each data set. Also, an error function can calculate quickly what are the differences and big gaps between each model. This research has used Excel software to compare multiple datasets and present the results as its shown in Figure 6.2.

$$\sigma = \sqrt{\frac{1}{N}[(x_1 - \mu)^2 + (x_2 - \mu)^2 + \dots + (x_N - \mu)^2]} \quad (2.1)$$

$$\frac{\textit{ApproximateValue} - \textit{ExactValue}}{\textit{ExactValue}} \times 100\% \quad (2.2)$$

3. SENSORS AND DATA COLLECTION

3.1 Experiment Goals

The goal of this chapter is to explain how general system is currently working. Later on how data was collected wirelessly and what type of data collection was needed within the scope of this research.

3.2 Test Facility

Currently, the test case for this research is the facility located in the Engineering/Technology (ET) building of the School of Engineering and Technology at IUPUI. Building has 31,957 square feet with 4 floors including basement and it was built in 1969. The current air handling unit is located in basement inside the mechanical room.

3.3 Floor Layout

Figure 3.1 shows the facility layout.

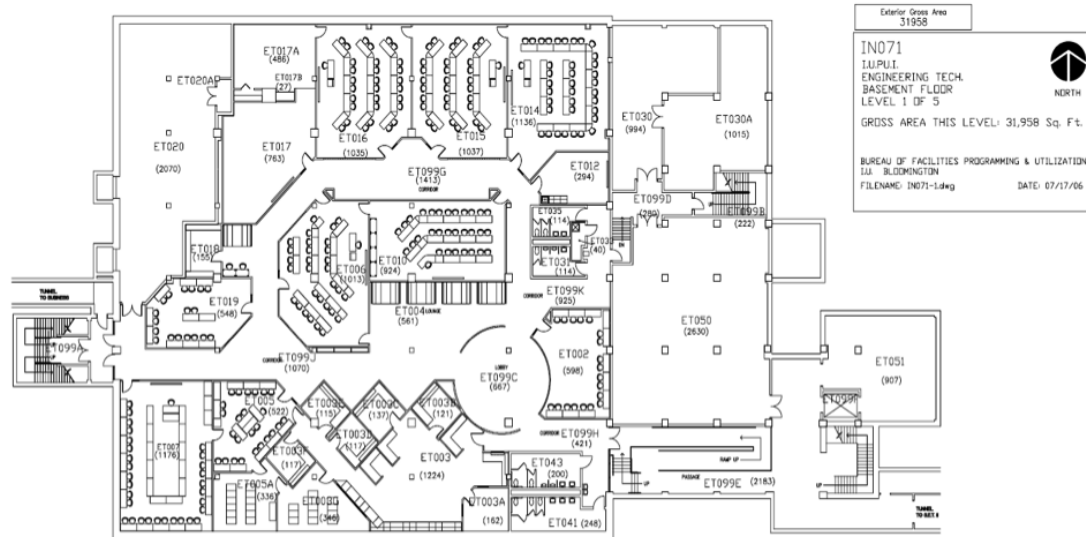

Fig. 3.1. Facility floor layout

3.4 Current AHU Design Specifications

Specific design parameters are listed in Table 3.1.

3.5 VAV Terminal Unit Specifications

Also specifications for all the design VAV boxes are included here in Table 3.2.

3.6 Building Automation System

ET building uses the automation system made by Johnson Control company. The software is called Metasys building management system. This software also has an online version through the Metasys Launcher application which can be reached and connected from anywhere using internet and specific IP settings. Metasys allows the

Table 3.1.
AHU Design Specifications

Components	Specifications
Preheat Coil	Surface Area: 40 sq. ft Rows:1 MBH (Mega BTU per hour):733
Cooling Coil	Surface Area: 40 sq. ft Rows:6 MBH (Mega BTU per hour):796
Supply Fan	Min OA CFM: 5000 Supply CFM: 17000 Horsepower:25 External Static Pressure:3 in. WC
Return Fan	Supply CFM: 17000 Horsepower:15 External Static Pressure:1.75 in. WC

user/users to view different system settings and sensor functioning with their current properties.

Metasys also has the functionality to work with field controller to perform some operator commands on the system. In the current research the access to the Metasys system was limited to only view certain data on Air handling unit coils and few more equipment, which was good enough within the scope of this work.

Table 3.2.
VAV terminal unit specifications

Terminal Units	Model no	D CFM	Min CFM	Max CFM	MBH	GPM	Rows	LAT
TB-01	DESV-10	1000	600	0.5	29.2	2.0	2	100
TB-02	DESV-10	1000	600	0.5	29.2	2.0	2	100
TB-03	DESV-10	1000	600	0.5	13.9	2.0	2	75
TB-04	DESV-10	1000	600	0.5	13.9	2.0	2	75
TB-05	DESV-10	1000	600	0.5	13.9	2.0	2	75
TB-06	DESV-05	300	300	0.5	6.5	1.0	2	75
TB-07	DESV-07	500	500	0.5	10.9	1.0	2	75
TB-08	DESV-07	500	500	0.5	10.9	1.0	1	75
TB-09	DESV-8	700	400	0.5	8.7	1.0	1	75
TB-10	DESV-07	500	500	0.5	10.9	1.0	1	100
TB-11	DESV-07	500	500	0.5	10.9	1.0	1	75
TB-12	DESV-07	500	500	0.5	10.9	1.0	1	75
TB-13	DESV-09	800	600	0.5	13.0	2.0	1	75
TB-14	DESV-09	700	600	0.5	10.9	1.0	1	75
TB-15	DESV-10	500	500	0.5	10.9	1.0	1	75
TB-16	DESV-07	500	500	0.5	10.9	1.0	1	75
TB-17	DESV-08	600	400	0.5	8.7	1.0	1	75
TB-18	DESV-08	600	400	0.5	8.7	1.0	1	75
TB-19	DESV-09	800	600	0.5	13.0	2.0	1	75
TB-20	DESV-10	500	500	0.5	10.9	1.0	1	75
TB-21	DESV-08	750	400	0.5	8.7	1.0	1	75
TB-22	DESV-08	750	400	0.5	8.7	1.0	1	75
TB-23	DESV-09	700	700	0.5	34.1	2.0	2	100
TB-24	DESV-10	925	700	0.5	34.1	2.0	2	100
TB-25	DESV-10	375	375	0.5	8.1	1.0	1	75

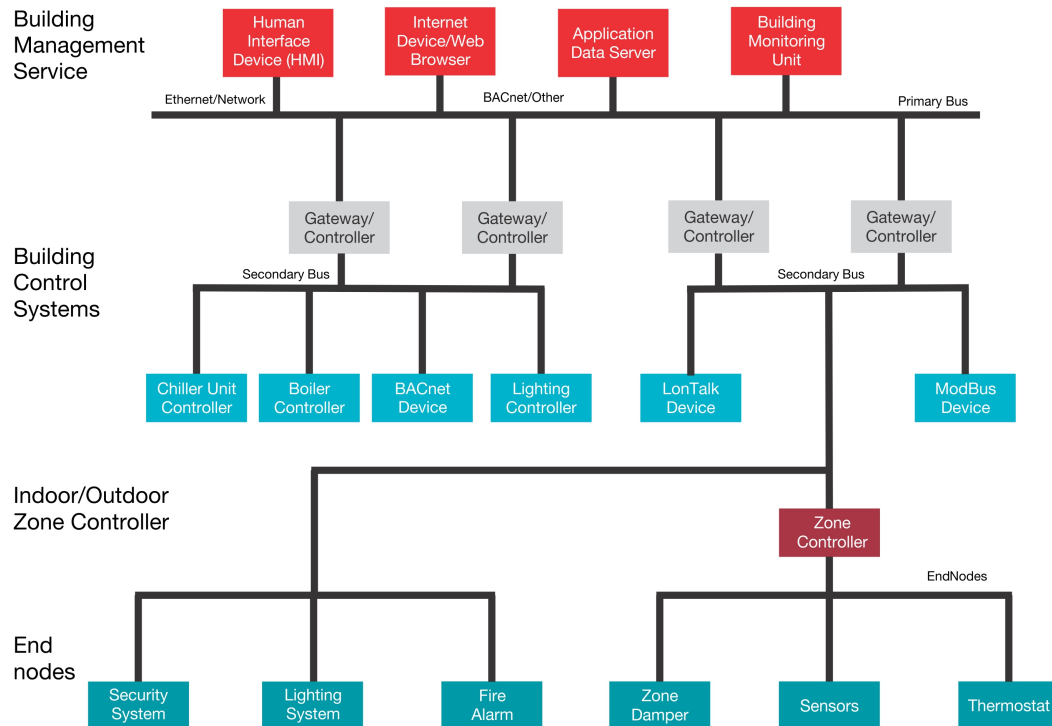

Fig. 3.2. Example of current building network (Wikipedia)

The architecture components and communication structure of Metasys are shown in Figure 3.2. Information from primary BUS can be sent and received through the system. Building management service has the functionality of changing all overall settings on the system but after that it would come down to building control system that would be Metasys software and simple commands for different units.

3.6.1 AHU List of System Inputs

Table 3.3 shows the inputs and outputs of the AHU that serves the ET basement. Some of the inputs and outputs are used for simulation.

3.6.2 Sensor Types

Averaging temperature sensors have been used to measure CHR-T, MA-T, PH-T and DA-T, they are available in Table 3.4.

3.6.3 Sensor Locations

Sensor locations are displayed in Figure 3.3 show the screenshot of the current system through the Metasys software. The figure also displays sensor locations and some roughly values of sensors.

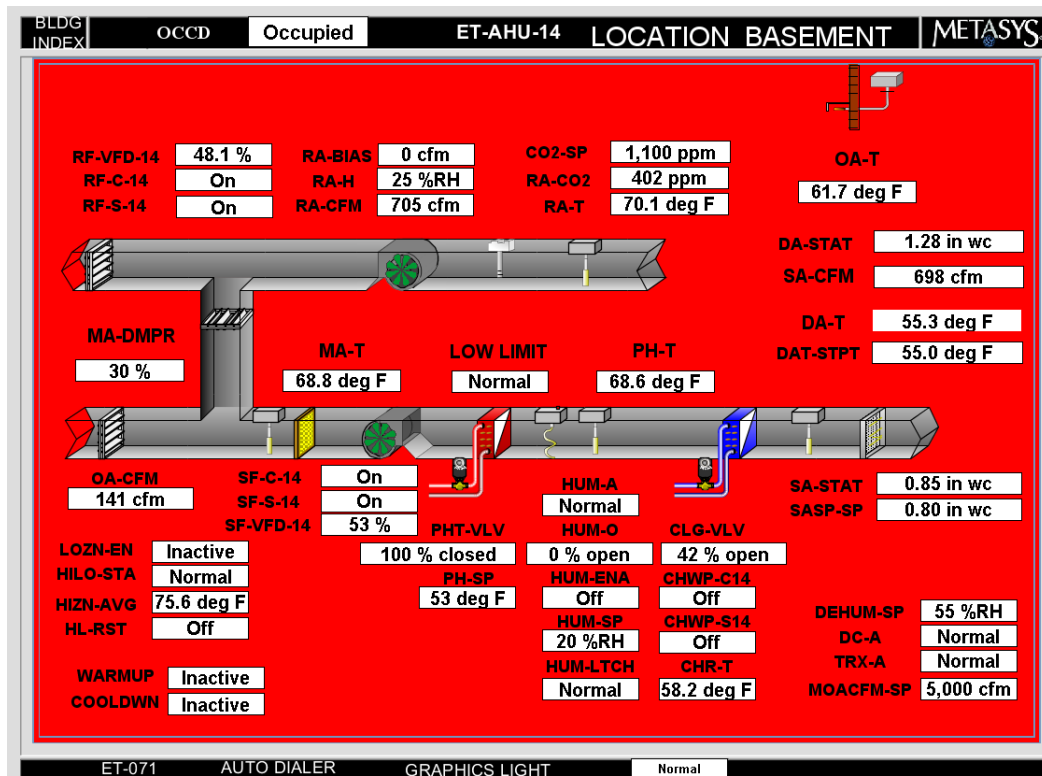

Fig. 3.3. Sensor locations of the AHU (Metasys Johnson Control)

3.7 Wireless Data Receiver

This research also has used wireless data system to collect CO_2 data in the basement. A fully functional device FFD was used to collect the information and connect to sensors using ZigBee network system. Also the CO_2 sensor is connected to this main communication network. The CO_2 sensors were looked within the range of breathing height from the floor about 48-72 inches. Also 24 inches far from the entrance of the rooms to make sure the data collections would be accurate on CO_2 levels.



Fig. 3.4. CO_2 sensor and FFD in hallway.

Figures 3.4, 3.5 and 3.6 show all locations that CO_2 sensors were installed. Locations installed are in hallways in the ET basement, class in ET019 and also in the lab ET010.

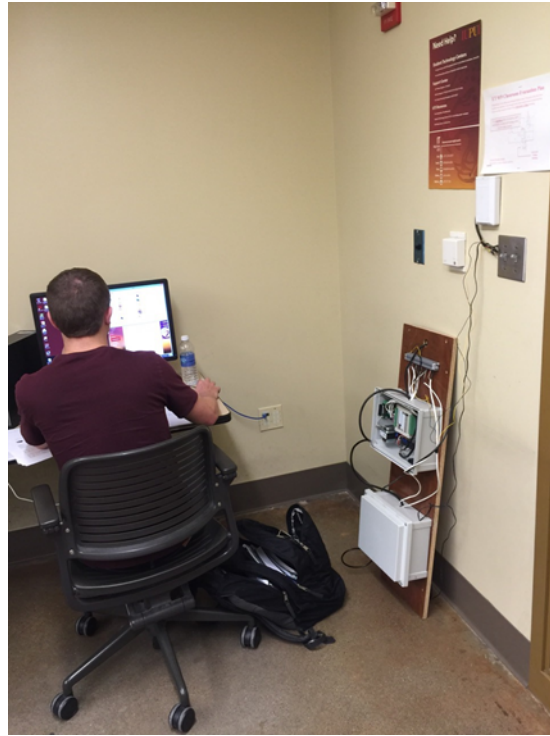

Fig. 3.5. CO_2 sensor and FFD in lab ET010.

Three locations were chosen based on most common places that students use during a regular day in the school. Locations of the sensor also were chosen based on manufacturing information listed on sensors manual.

Table 3.3.
AHU I/O List

Parameter type	Parameter	Description	Unit
Analog inputs	AI1 OA-CFM	Outside air flow	CFM
	AI2 MA-T	Mixed Air Temperature	F
	AI3 SA-CFM	Supply Air Flow	CFM
	AI4 PH-T	Preheat Air Temperature	F
	AI5 DA-T	Discharge Air Temperature	F
	AI6 DA-STAT	Discharge Air Static Pressure	In. H2O
	AI7 SA-STAT	Supply Air Static Pressure	In. H2O
	AI8 CHR-T	Chilled Water Return Temp	F
Analog outputs	AO1 SF-VFD	Supply Fan VFD	%
	AO2 RF-VFD	Return Fan VFD	%
	AO9 MA-DMPR	Mixed Air Damper	%
	AO10 PHT-VALVE	Preheat Valve	%
	AO11HUM-OUTPUT	Humidifier Output	
	AO12 CLG-VALVE	Cooling Coil Valve	
Digital inputs	DI1 SF-S	Supply Fan Status	NA
	DI2 RF-S	Return Fan Status	
	DI3 CHWP-S	Chilled Water Pump Status	
	DI4 HILO-STA	HI LO Static Status	
	DI5 LOWLIMIT	LOWLIMIT Status	
	DI6HUMALARM	Humidity Alarm	
	DI7DC ALARM	DC Power Supply Alarm	
	DI8 TRX-A	Transformer Alarm	
Digital inputs	DO3 SF-C	Supply Fan Command	NA
	DO4 RF-C	Return Fan Command	
	DO5HUMENABLE	Humidity Enable	
	DO6CHWP-C	Chilled Water Pump Command	

Table 3.4.
Sensor types

Sensor	Part no	Output signal	Range	Accuracy
CHR-T	TE-632AP-1	1k ohm	-50 to 220F	0.73F at 70F
RA-T/H	HMD60Y	4-20mA	0-100% RH	2% RH
MA-T	TE-6328P-1	1k ohm	-50 to 220F	1.08Fat 70F
PH-T	TE-6328P-1	1k ohm	-50 to 220F	1.08Fat 70F
DA-T	TE-6328P-1	1k ohm	-50 to 220F	1.08Fat 70F
DA-STAT	DPT241	4-20mA	0-10 in WC	0.5%



Fig. 3.6. CO_2 sensor and FFD in lab ET019.

3.8 MODBUS Network Connection

All information through the FFD is being sent to what is called PAN coordinator shown in Figure 3.8. Pan coordinator basically is a wireless router which collects all the information from the sensors.

MODBUS Network / Device Properties

Update

Unit	MAC Address	Type	Version	Status	Name	Set Name
3	00063F00000109E2	WC21S_01	0037	0000 (OK)	FFD small IAC room	<input type="text"/>

Registers	Value	Set	Format	Remark
300	0000 (OK)		Unsigned Hex	Status (OK or NoLink or LowBattery)
301	3300		Signed Decimal	Power Voltage (mV)
302	12	<input type="text"/>	Signed Decimal	Report Interval (Seconds)
303	-21		Signed Decimal	Temperature 1 (°F) or Value 1
304	69		Signed Decimal	Temperature 2 (°F) or Value 2

[Configure System](#)
[Configure Gateway](#)
[Configure MODBUS](#)

Fig. 3.7. MODBUS network

Figure 3.7 shows the MODBUS network which is built in for PAN coordinator. Multiple different FFD and RFDs can be connected to this MODBUS network. The IP address can only be access via school network.



Fig. 3.8. PAN coordinator

A configuration on the MODBUS network was already done in previous researches. The current work had an extra step to add CO2 sensors to FFD and attached to the system. Configuration of the MODBUS network is also available on Reference [32].

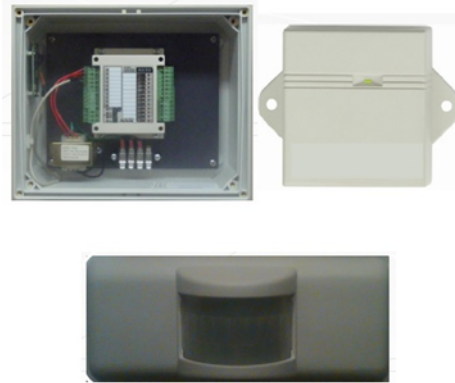

Fig. 3.9. Example of sensors attached to FFD

3.9 AHU Sequence of Operation

Sequence of operations is documented by Johnson Control and is available to the building staff. Paragraphs below are exactly what is/was listed in the air handling unit sequence of operation from AHU-1 (Drawing Number 050061-1.1) on Figure 3.10.

1. Air handling unit start/stop: The air handling unit should work continually and lowest temperature has been set to 60 degrees Fahrenheit.
2. Preheat valve: Once air handling unit stops working all outside dampers should be closed, also all valves would be closed. Pre heat valve stays at 50 degrees Fahrenheit.
3. Duct static pressure control: Duct static pressure is set on 1.75 in WC. Supply fan should also be set for the higher limit on 4.5 in WC and lower limit of 5 in WC.
4. Carbon dioxide control (demand control ventilation/DCV): Current CO2 level for the system has been set to between 600ppm and 1100ppm. The outside air damper is set to minimum of 10% all the time for minimum ventilation.
5. Economizer/mixed air damper control: Minimum of 5% the fan delivery flow rate has been set to mix the air between outside and indoor air.
6. Cooling coil control: Cooling coil temperatures are set to 55 till 60 degrees Fahrenheit from average of all highest zone temperatures. Also cooling recirculation

pump will start if the temperatures fall below 40 degrees Fahrenheit to avoid any freezing. Heating and cooling warm-up

7. Outside dampers: When temperature is below 45 degrees Fahrenheit all outside dampers will be closed. The outside only will be used in the building if the outdoor temperature is between 45 and 68 degrees Fahrenheit.

8. Cooling pull-down: In case of emergency, fire, freezing temperature, or smoke detection the air handling unit will be stopped automatically.

4. THERMODYNAMIC AND MATHEMATICAL MODELING

In this section the models and equations are presented. After attaching sensors and getting wireless information we used hourly data to run the model. There are several inputs to this model that are listed later on. Equations are all based on thermodynamic laws. Overall performance for the coils on air handling unit is modeled.

In this thesis the focus of the modeling is on cooling, heating coils, and heat exchanger as well as energy usage for the fans. Individual subsystems were programmed for this model with EES software. Most of the information for EES modeling was imported from the Metasys and air handling unit monitoring software as described in the previous chapter. Also coil information was taken from manufacturing data sheets for this specific air handling unit.

Chilled water and team pump were not included in this model since the building purchases these two for the whole campus so there is no chiller or boiler inside the house to make these two materials. Temperature data was taken from Indianapolis international airport location and website.

There are different scenarios assumed for each coil performance methods that are described in details in Chapter 5. Number of transfer units and log mean temperature difference also were used to tune the model and find the temperature relations for the heat exchangers. There are couple of EES library functions used for certain analysis such as fouling factors, conductance, and heat exchanger correlations that are described in each section, Figure 4.1 shows the main energy consumers in air handling unit.

Currently humidifier for this air-handling unit is not functioning but it is taking to account for the model. Current data sets were mostly for end of summer and beginning of fall where the weather conditions are moderate.

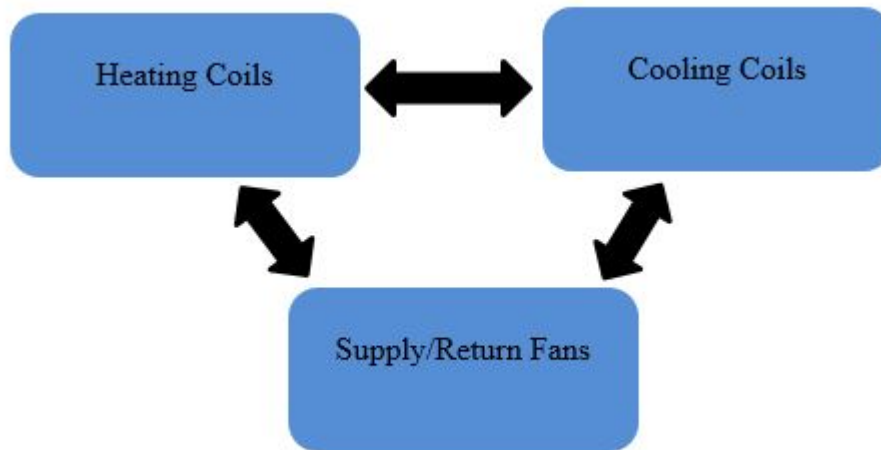

Fig. 4.1. Main energy consumers

Dehumidification occurs in cooling part of the model so the EES model focuses on cooling at the beginning since it has more inputs for the system equations. Later in the next section the model for the heating side also is presented.

4.1 Number of Transferred Units

Number of transfer unit method was used to model a counter-flow heat exchanger operation in this modeling. This method is mostly used in heat exchangers and especially in a condition that there is no insufficient information available. In most situations where the temperatures for inlet and outlet of heat exchangers are specified the log mean temperature difference is used. But when any of this information is not available the NTU method can be used. This method works based on the maximum possible heat transfer that can be achieved in heat exchangers, so in this method one fluid will face a maximum heat transfer.

In this case the inlet temperature for the hot and cold stream are compared and used to find the maximum heat transfer.

$$q_{max} = C_{min}(T_{h,i} - T_{c,i}) \quad (4.1)$$

The effectiveness is basically the ration between the actual heat and maximum heat transfer.

$$E = \frac{q}{q_{max}} \quad (4.2)$$

In this case the actual heat transfer equation is presented below

$$q_{max} = C_h(T_{h,i} - T_{c,o}) = C_c(T_{c,o} - T_{c,i}) \quad (4.3)$$

From maximum heat transfer and effectiveness equations, the actual heat transfer equation can be derived as below

$$q_{max} = EC_{min}(T_{h,i} - T_{c,i}) \quad (4.4)$$

$$E = f\left(NTU, \frac{C_{min}}{C_{max}}\right) \quad (4.5)$$

So, this general equation can be assigned for any heat exchanger. Calculating heat capacity ratios the Cr can be calculated and later will be used in the main NTU equation.

$$C_r = \frac{C_{min}}{C_{max}} \quad (4.6)$$

$$NTU = \frac{NTU}{C_{min}} \quad (4.7)$$

The overall heat transfer for the system can be written in this form, A is also the heat transfer area for the heat exchanger. Based on Cr the equations for parallel flow heat exchanger and counter-current flow heat exchanger can be derived.

$$E = \frac{1 - \exp[-NTU(1 - C_r)]}{1 - C_r \exp[-NTU(1 - C_r)]} \quad (4.8)$$

The equation above is calculating effectiveness and number of transfer units for counter current flow. Also when condensation occurs and during the substance phase change the C_r would be zero. So the general equation for number of transfer unit can be written as

$$E = 1 - \exp[-NTU] \quad (4.9)$$

Also an important factor for number of transfer units is how many shell and tubes are used in air handling units. [33]

4.2 Chilled Water Model

The first portion of chilled water modeling includes inputs of Metasys software from excel file. The inlet humidity ratio and dew point are calculated for the incoming air to unit. In case the entering water temperature would be less than air the water inside air would start to condensate. Humidity Ratio and Dewpoint for Air as :

$$\text{Air } H_2O, P = p_a, T = T_{a,in}, R = RH_{a,in} \quad (4.10)$$

$$\text{Air } H_2O, P = p_a, \omega = \omega_{a,in}, R = 1 \quad (4.11)$$

Equations above show example of different parameters and thermodynamic characteristics for material can be called using built in functions in EES code.

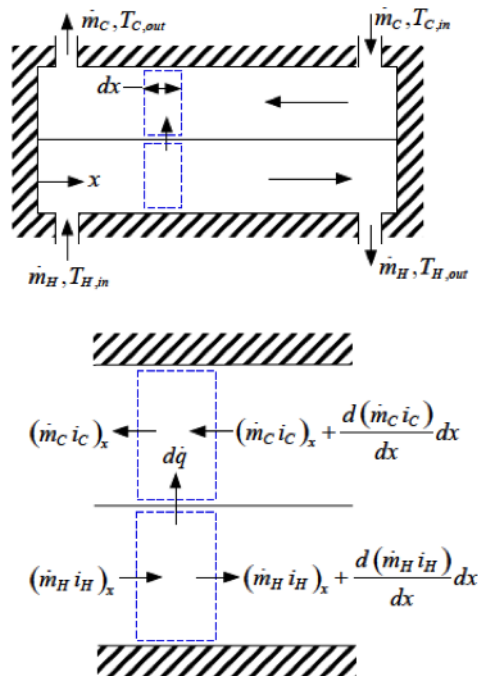

Fig. 4.2. Counter flow heat exchanger example no mass transfer [33]

Figure 4.3 also shows how the generic model in this software works and was set up. The majority of input values was imported from the sensors and building automation system. Then parameters and governing equations were made in the modeling equations. Output for the system was calculated based on the identification model.

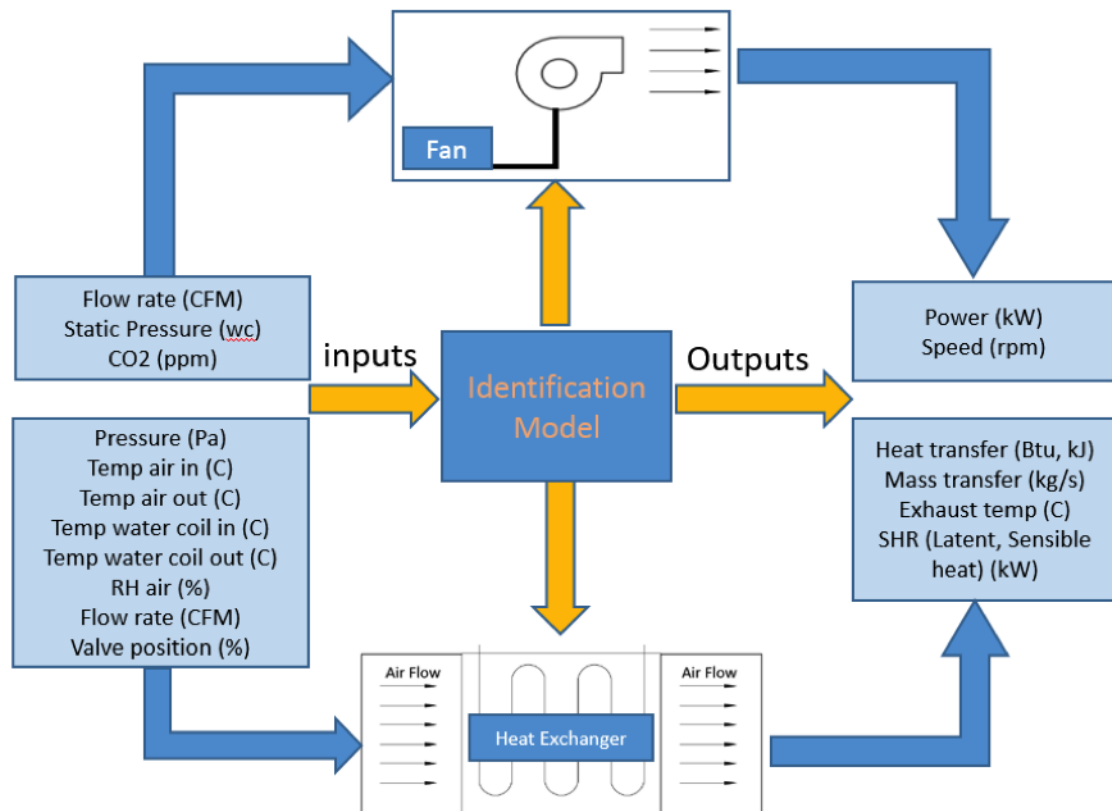

Fig. 4.3. Flow chart for identification model inputs and outputs.

As it was explained earlier the chiller model, it has multiple settings of equations for reading dew point and humidity ratios. Later on these information will be related and used to next sub modules.

Based on the sequence of air handling units there are three different scenarios for when the cooling and heating coils should be enabled. Using the input values

if temperature entering the air-handling unit is lower than 45 degrees Fahrenheit, the cooling coil will be locked out and only heating coil will perform. If the inlet temperature would be from 45 to 65 degrees Fahrenheit then economizer would come to work and not all the air-cooling coil would be enabled, instead outside air would be used to cool the air. Currently this damper positions and the amount of mixing air is being imported from the automation system. In case that the air temperature is above 65 degrees the cooling coil and dehumidification process would be fully functional.

In the next section there will be more information about how the internal flow through the tube would be modeled using EES software. The inner diameter of the tube can be calculated as below.

$$D = \frac{D_{out} - D_{in}}{2} \quad (4.12)$$

And also the total length for the tube would be modeled as:

$$L(tube) = N(t, row)N(t, col)Width \quad (4.13)$$

So heat transfer resistance for water and inner surface of tube can be computed using.

$$R_{in} = \frac{1}{\pi - D_{in}L_{tube}h_w} \quad (4.14)$$

4.3 Internal Flow Model

Internal flow for pipe models can be used through the built in functions and libraries inside the Engineering Equation Solver. The equation then can come as below:

$$PipeFlow = (Water, T_{avg}, p_w, m_{dot,w}, D_{in}, D_{tube}, D_{in}, h_{bar,w}, Nusselt_{bar,w}) \quad (4.15)$$

So in this line of code we are simply calling Pipe flow function based on the inputs that are given to the system. So the procedure fist calls unit functions and make sure the units are all matching. Then the pipe flow turbulent equations will be executed using below inputs:

$$Re, Pr, \frac{L}{D}, Roughness, Nusselt, friction \quad (4.16)$$

In the built-in functions there are multiple warnings set up in case the flow is not turbulent or the Reynolds value is less than 2300. Also the same applies for Prant, Nusselt number and the roughness values for the fluid. The procedure also takes to account multiple simple factors, such as pipe diameters, heat exchanger surface, number of fins and etc. Figure 4.4 shows the internal flow inputs for pipe flow function.

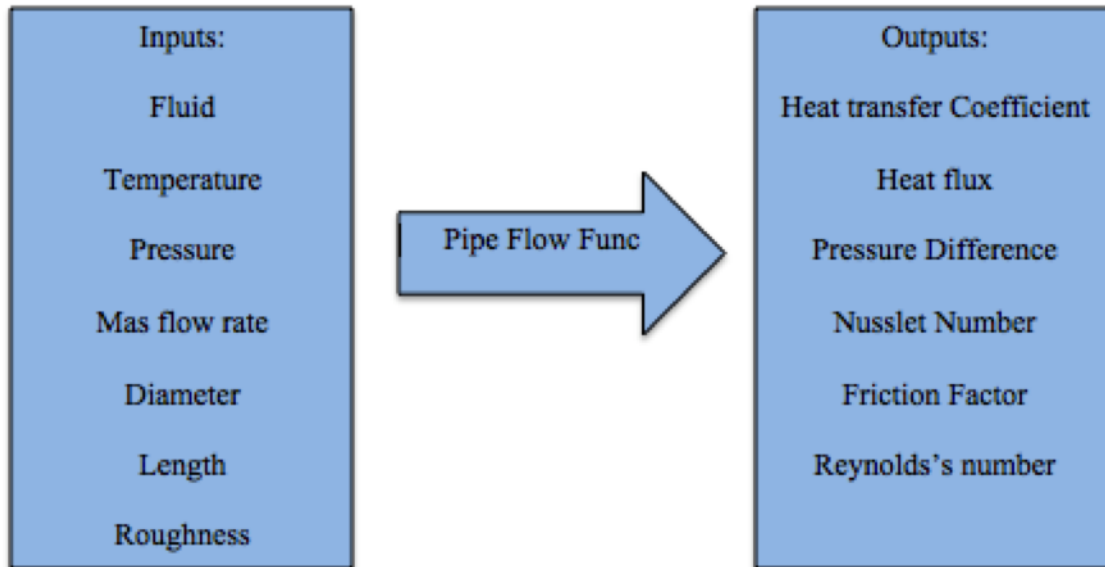

Fig. 4.4. Internal flow model Input/Outputs

4.4 Fouling and Conduction Resistance Model

As discussed in previous sections EES has great library of thermodynamics functions. One of the other factors/functions that can be calculated using the built-in function is fouling resistance. Fouling is basically the unwanted material, which cov-

ers the inside of the tube and reduces the performance of the system and conductance of the tubes. General equation of the fouling conductance can be written as:

$$R_{f,in} = \frac{R''_{f,in}}{\pi D_{in} L_{tube}} \quad (4.17)$$

R''_f is the fouling factor returned by this function and R_f is the constant fouling factor. Fouling would increase the resistance to the heat transfer between the fluid and surface of the pipe material. Fouling is dependent on different factors such as temperature, fluid type, surface material, and fluid velocity. [34–36] Also the conductivity of the pipe can be modeled as:

$$R_{cond} = \frac{\ln\left(\frac{D_{out}}{D_{in}}\right)}{2\pi k_m L_{tube}} \quad (4.18)$$

4.5 Heat Exchanger Model

After modeling the chilled water and corresponding resistances, using this information the heat exchanger model can be made. Like it was discussed in previous sections there are built-in functions in Engineering Equation Solver that help to solve complicated thermodynamic equations like these particular heat exchanger correlations:

$$HeatExchanger(TypeHX, m_{dot,a}, \omega \times HT_{avg}, P_a, h_{bar}) \quad (4.19)$$

This function uses the various dimensional parameters, which are applicable for specific finned tube geometry on heat exchangers. Most of the functions in EES at the beginning also they perform unit checks and there will be warnings generated if there are mismatches in the units. The inputs and outputs for these functions are listed in Figure 4.5.

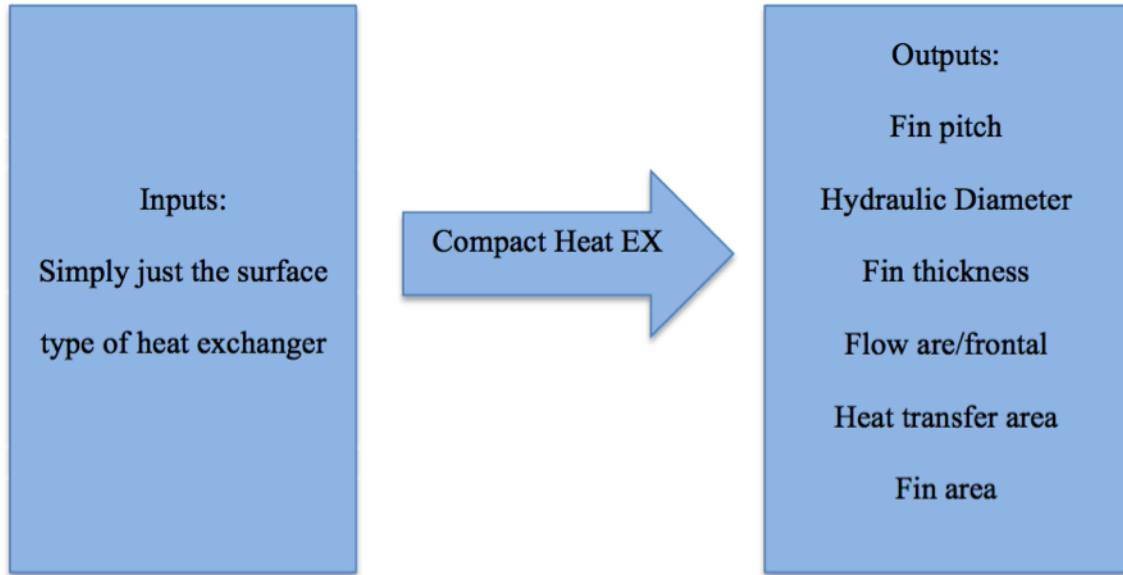

Fig. 4.5. Compact heat exchanger model Input/Outputs

Also the total surfaces for the fins and unfinned tubes can be model using equations below:

$$A_{s,fin,tot} = 2 \left(\frac{W}{p_{fin}} \right) \left(HL - N_{t,row} N_{t,col} \frac{\pi D_{out}^2}{4} \right) \quad (4.20)$$

$$A_{s,unfin} = \pi D_{out} L_{tube} \left(1 - \frac{th_{fin}}{p_{fin}} \right) \quad (4.21)$$

4.6 Cooling Coil Model

As discussed earlier this modeling approach uses two different methods to come up for the heat transfer values in cooling and heating coil. The details of each wet coil and dry coil will be discussed later in Section 4.8. The general approach for each model is mainly range limit or working condition assumptions on the heat exchanger parts then using thermodynamic energy balance equations to calculate heat transfer based on assumptions. Important factor in cooling coil model, as mentioned earlier,

is the dew point temperature values for air when condensation happens. Calculating heat capacity for each section of the coil and also air would complete general equation of heat transfer. Also discussed earlier effectiveness method and number of transfer units would allow us to estimate temperature and models more accurately:

$$\dot{q}_{dc,max} = \dot{C}_{dc,min} (T_{a,in} - T_{w,in}) \quad (4.22)$$

$$\epsilon_{dc,max} = \frac{Q_{dc}}{Q_{dc,max}} \quad (4.23)$$

4.7 Pre-heat Coil Model

Pre heat coil basically prevents cooling coil from freezing. The valve for pre heat coil opens when the temperature is below 50 degrees Fahrenheit to keep the coil from freezing. The modeling for heating and cooling coil is almost the same except the fact that there will not be any separation of wet dry coil and, in fact, the entire coil will be considered as dry.

This part of modeling also uses same energy balance and heat transfer equations used in cooling coil model. In the next section there would be detailed information of energy balance and heat transfer equations for each method.

4.8 Coil Performance Model

As mentioned earlier this research includes methods of calculating the performance for coils inside the air-handling unit. The advantages of this method is basically based on the mechanical inputs for each system and what's called semi-mechanical modeling. Consider knowing some mechanical information about the coils and using them as the input to the system. Later sensor information will be used to provide rest of thermodynamics characteristics for the equations.

4.8.1 Dry Coil Model

Dry wet coil method divides coil into two different regions: dry part and wet part. As it was explained in Figure 2.12 dry part is considered the starting point part until the saturated line or the dew point temperature. So the input temperature to dry coil is normal outside air temperature and also the output temperature of the coil is the dew point temperature.

$$T_{a,dc,out} = T_{dp} \quad (4.24)$$

Using the internal library of the EES we can also calculate the specific heat capacity of the moist air. On the other side we also determine the specific heat capacity for the water.

$$\dot{C}_{a,dc} = \dot{m}_a C_a'' \quad (4.25)$$

$$\dot{C}_w = \dot{m}_w C_w \quad (4.26)$$

Assuming that the cooling coil is large enough, so the temperature can reach the dew point. After that we can calculate the amount of heat transfer for dry coil.

$$\dot{q}_{dc} = \dot{C}_{dc}(T_{a,in} - T_{a,dc,out}) \quad (4.27)$$

Calculating minimum heat capacity

$$\dot{q}_{dc,max} = \dot{C}_{min,dc}(T_{a,in} - T_{w,in}) \quad (4.28)$$

At the end using effectiveness of the dry coil we can calculate the heat transfer for dry coil method.

$$\epsilon_{dc} = \frac{q_{dc}}{q_{dc,max}} \quad (4.29)$$

4.8.2 Wet Coil Model

In order to go through the analysis for wet coil, first we need to determine how much fraction of the heat exchanger was used as a dry coil so we can the rest of resistance and area as wet coil.

$$UA_{dc} = NTU_a \dot{q}_{min,dc} \quad (4.30)$$

Using number of transfer units method we can determine the conductance required in dry coil. For calculation of conductance we need to use the Heat exchanger function in the EES. As it was discussed in Chapter 2 there are two ways of analysis for Heat Exchangers. One is the number of transfer units and the other is log mean temperature difference. So in this scenario was decided to move on with NTU analysis since we are separating two parts in the heat exchanger and temperature values should be estimated.

There are two general forms that EES uses to calculate the heat exchanger analysis.

$$\epsilon = HX(\text{TypeHX}, Ntu, C_1, C_2, \text{Return}) \quad (4.31)$$

or

$$Ntu = HX(\text{TypeHX}, \epsilon, C_1, C_2, \text{Return}) \quad (4.32)$$

First function reruns epsilon value and second option returns number of transfer units.

The flow configuration is defined by different types of flows, which are listed:

'parallelflow' 'counterflow' 'crossflow both unmixed' 'crossflow one unmixed' C1 must be the unmixed fluid. 'shell and tube N' 'regenerator'

C1 and C2 are capacitance rate in above equations that in some cases we should be careful choosing them. In the most cases they do not matter which fluid is C1 or C2, but in a cross flow heat exchanger C1 should be the unmixed fluid. Mass flow rate (e.g., kg/s or lbm/hr) and fluid specific heat (e.g., J/kg-K or Btu/lbm-R) have the output of capacitance rate. Calculating conductance we can get the total resistance of the dry coil by the inverse of conductance.

$$R_{dc} = \frac{1}{UA_{dc}} \quad (4.33)$$

So at the end the total resistance of the water side is made up by fouling resistance, resistance to conduction through the tube and convection resistance to air side.

$$R_{dc} = \frac{R_{in} + R_{f,in} + R_{cond}}{F_{dc}} + \frac{1}{h_a A_{tot} F_{dc}} \quad (4.34)$$

F-dc would give us the fraction or percentage of heat exchanger used as the dry coil. So the rest of heat exchanger will be used as the wet coil.

$$F_{wc} = 1 - F_{dc} \quad (4.35)$$

4.8.3 Enthalpy Based Effectiveness

Enthalpy based effectiveness basically considers the coil as entirely wet based on the idea that not all the air will get into the same situation of dehumidification and condensation. Air that is passing closer to the fin and towards the center of the coil, will get more energy transfer with result of dehumidification. Also, some air can bypass the coil since they are not in the center of the coil. This method can actually explain that even though the mean air temperature is somewhat greater than dew point temperature but still condensation can occur (Figure 4.6).

In this case the effectiveness is based on the enthalpy and humidity ratio but not the temperature.

$$\epsilon = \frac{\omega_{a,in} - \omega_{a,out}}{\omega_{a,in} - \omega_{a,out,min}} \quad (4.36)$$

$$\epsilon = \frac{i''_{a,in} - i''_{a,out}}{i''_{a,in} - i''_{a,out,min}} \quad (4.37)$$

The enthalpy out and relative humidity can be calculated using these two equations. After using the energy balance equation we can find the heat transfer and mass balance for coil analysis.

Once we assume the entire coil is wet, we can calculate the heat capacity ratio in EES based on the equation below.

$$C''_{sat,a,ebe} = \frac{[i''_a(T_{a,in}, p, RH = 1) - i''_a(T_{a,out,ebe}, p, RH = 1)]}{(T_{a,in} - T_{a,out,ebe})} \quad (4.38)$$

Since it is assumed coils are entirely wet, relative humidity value is set to 1. Therefore, the capacitance rate of air can be modeled as:

$$\dot{C}_{a,ebe} = C''_{a,sat} \dot{m}_a \quad (4.39)$$

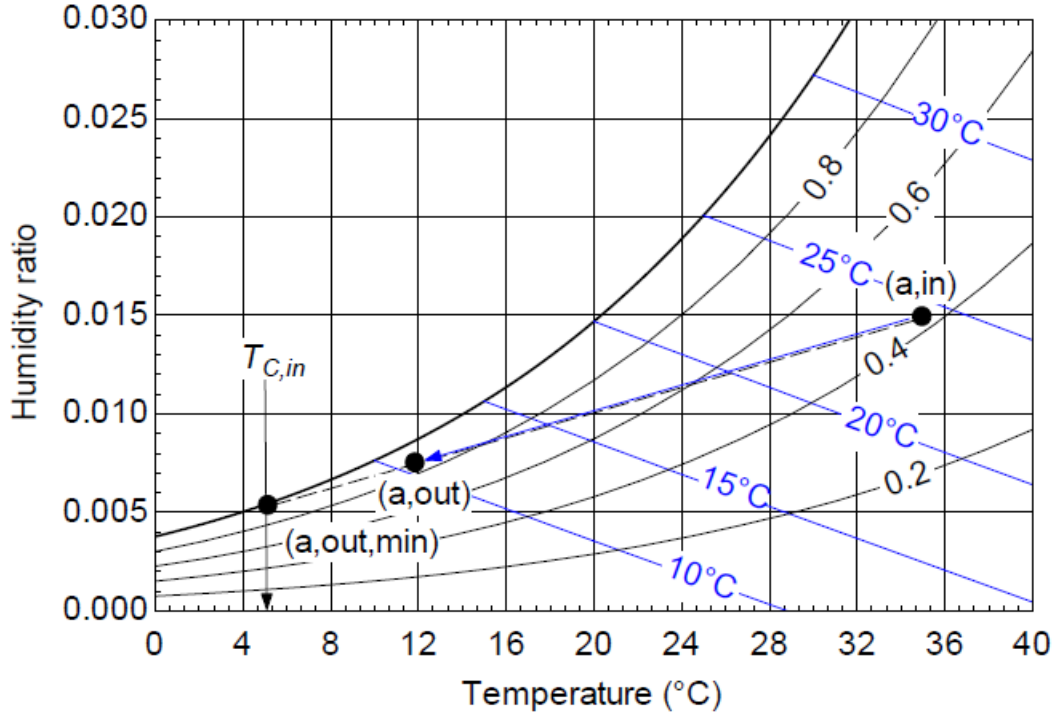

Fig. 4.6. Enthalpy based effectiveness air path assumption [33]

Once the total coil is wet, the thermal resistance can be calculated as.

$$R_{ebe} = R_{in} + R_{f,in} + R_{cond} + \frac{c''_a}{h_a c''_{a,sat,ebe} A_{tot}} \quad (4.40)$$

And therefore the conductance of the wet coil is the inverse of resistance:

$$UA_{ebe} = \frac{1}{R_{ebe}} \quad (4.41)$$

The number of units as it was explained before is calculated using equation below:

$$NTU_{ebe} = \frac{UA_{ebe}}{\dot{C}_{min,ebe}} \quad (4.42)$$

An the end Heat Exchanger function in EES is used model the heat exchanger in enthalpy based effectiveness method. Using also psychometric chart the outlet air enthalpy and relative humidity is calculated. The rate of heat transfer and also rate of condensation is thermodynamically modeled as:

$$\dot{q}_{ebe} = \dot{m}_a (i''_{a,in} - i''_{a,out,ebe}) \quad (4.43)$$

$$\dot{m}_{cond,ebe} = \dot{m}_a(\omega_{a,in} - \omega_{a,out,ebe}) \quad (4.44)$$

Values and results of these equations are discussed in Chapter 6. Both models give us amount of heat transfer and also amount of condensation, but since the origin of the models is different we are expecting close results, but slightly different as it is discussed in Chapter 6.

5. POWER OUTPUT CONTROLLER

Ventilation rates in buildings are mostly ruled by the organization standards and regulations. These rates can affect the whole energy usage of the air handling units. Many of current regulations are based on the zone and areas in different countries and continents rather than focusing on the actual healthy factors of the building [37].

After investigating in current test building it was found that the ventilation for the air handling unit is on all the time since there is no good way of measurement for the fresh air needed inside the building. The building will operate more efficient if different classrooms air ventilation can be optimized by implementing a real-time occupancy-based controller.

The idea of using this power output controller is to optimize the fan energy consumption in each room based on CO_2 levels and air ventilation needed to lower the CO_2 profile in the building. By this method, the waste energy of unnecessary ventilations can be reduced and eliminated. Also this assumption for air ventilation should be always valid since air quality is the main reason of ventilating the air inside the building. This occupancy level is linked to the CO_2 level that can be measured. This will be discussed in details later in Chapter 8.

5.1 Fuzzy Logic Controller

The term Fuzzy comes from the opposite meaning of true and false. This research has chosen this method to make a continues controller in order to estimate and model the output power for the fan, VAV or etc. This model can be general and be used by many other applications. In this research CO_2 values have been chosen to be the input to the system. Fuzzy logic controller consists of three sections: input, output,

and membership functions. Figure 5.1 shows the schematic of fuzzy logic controller used in this work.

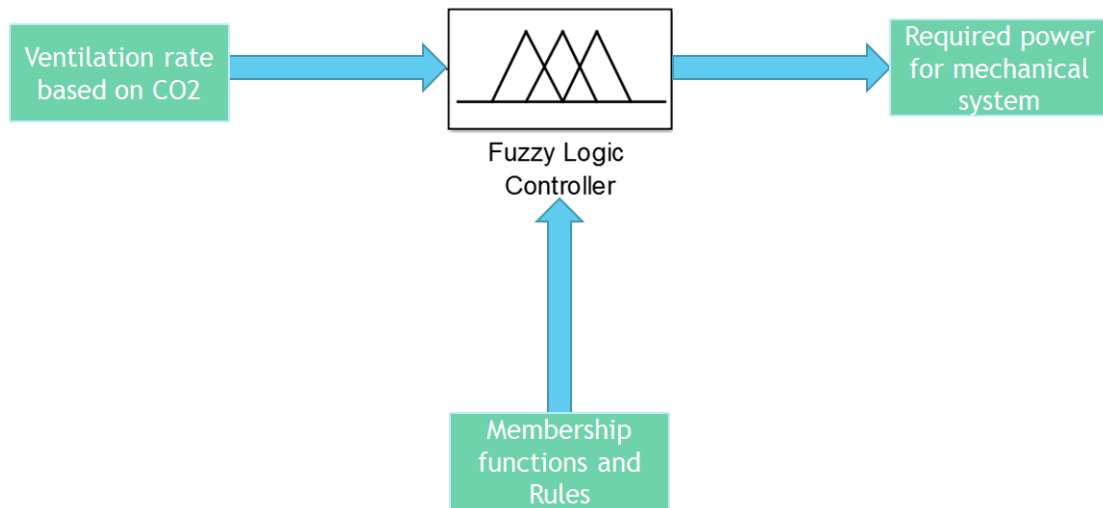

Fig. 5.1. Current fuzzy logic controller

The membership functions have been chosen based on the characteristics of the air handling unit and amount air quality needed in the building.

5.2 Membership Functions

Membership functions are set of rules that are determined based on the system characteristics. Figure 5.2 shows how three different regions cold, warm and hot are corresponding with temperature axis to define the rule of functions.

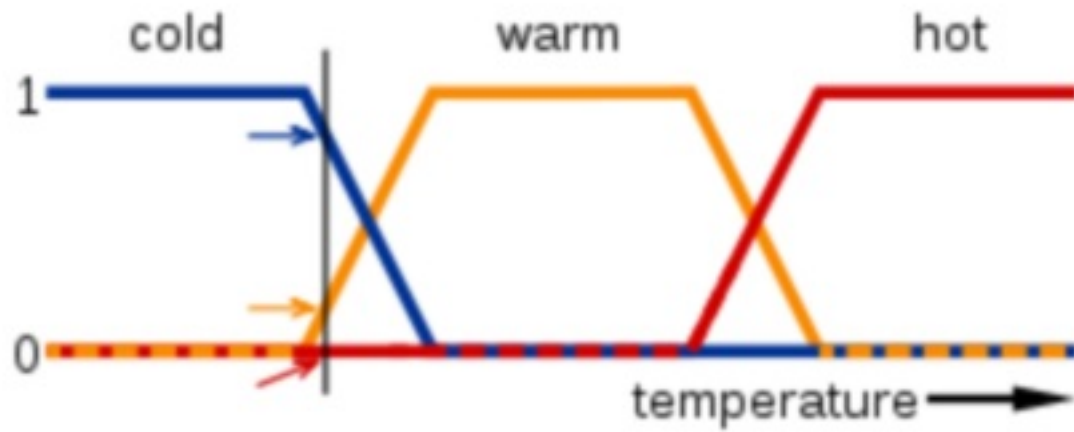

Fig. 5.2. Fuzzy logic membership functions

5.3 Simulink Control Blocks

Matlab Simulink software has been used to model the fuzzy logic controller and setting the membership functions rules. There is a Matlab script also has been written to work inside the fuzzy logic block diagram.

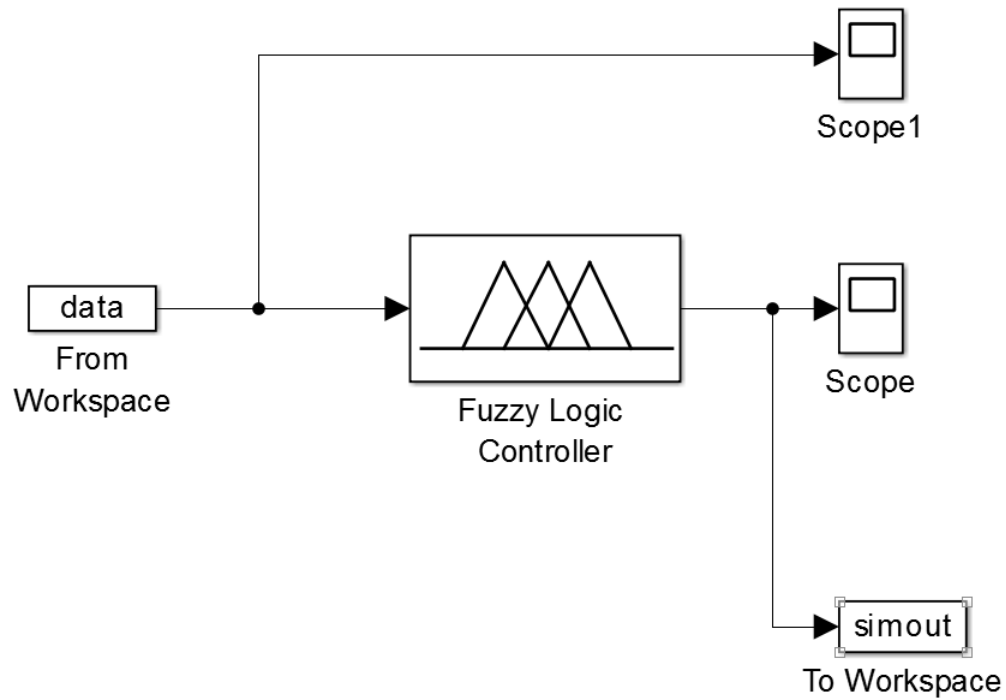

Fig. 5.3. Example of Simulink blocks

Data is generated from the script into the workspace. Multiple functions can be called from fuzzy logic controller as well as membership functions and rules defined for the system. Scopes for the system will allow us to view and plot the results real time. So, as long as the modeling is running we can visualize the output of the controller. More details and results of the controller output as well as energy reduction associated with using this type of controller will be discussed later on in Chapter 8.

6. MODELLING RESULTS AND VALIDATIONS

6.1 AHU Model Validation

Real-time data were collected during the analysis time as the inputs of the model. Some of these inputs are as follows: physical properties of the coils and air handling unit, volumetric flow rate of air, the static pressure for the duct, inlet air temperature, inlet air relative humidity, and inlet water temperature.

The heat exchange comparison and AHU modeling validations are explained later in this chapter. The validations in heat exchanger modeling parts were based on comparison of two different modeling results with experimental results of heat exchanger. Errors on heat exchanger were mainly compared based on inlet air relative humidity, since it was concluded that has the most effect heat exchange values variations. Also solutions and recommendations are provided when the modeling does not meet the accuracy requirements. CO_2 model validations were based on how the models meet the air quality requirements mainly comparing as ppm values (details in Section 6.3). Since the most important factor in ventilations needed in buildings is CO_2 ppm.

Pressure for chilled water was used as the average of campus building since there is no specific sensor for this test building. The data is valid since the usage for building is almost the same and chilling water is being purchased for the whole campus. Information for water flow rate also was collected. Table 6.1 shows different data sets were collected during the analysis. Data set number one shows building data collected for heat exchanger modeling as shown the same as model inputs in Figure 4.3. Data set number two shows data collection for CO_2 analysis the results of which will be discussed later. CO_2 data collections were test with 2 hours of dataset then data was collected for a whole week in order to get persistent weekly results and energy reduction information. In general for heat exchanger modeling was expected to re-

Table 6.1.
Description of data sets

Data Set	Data Collection Period	Sampling Time	No. of Samples
1	09/17/2015-10/03/2015 Building data for heat exchanger modeling	16 hours	2,831
2	09/29/2015 CO ₂ sets	2 hours	200

ceive more accurate results on enthalpy-based effectiveness. For CO_2 validation also fuzzy logic controller was expected to be more accurate and robust to the ventilation demand.

6.1.1 Dry Wet Coil Model Validation

Figure 6.1 shows a comparison between experimental values for the amount heat exchanged and the wet dry coil modeling. As it is shown in the graph there is a good consistency between model and experimental values. The submodel which was test here is the heat exchanger. There is also error associated with specific points and data set in the model that is discussed later in this paper. The main difference of this modeling and experimental values is that the modeling on heat exchanger makes two different scenarios for dry and wet region but experimental values are calculated based on the input and output of the heat exchanger. The model cannot predict overshoot when system starts. When there is an overshoot in experimental values it takes time for the model to pick up with the real values but at the end the trend for both data sets are almost the same.

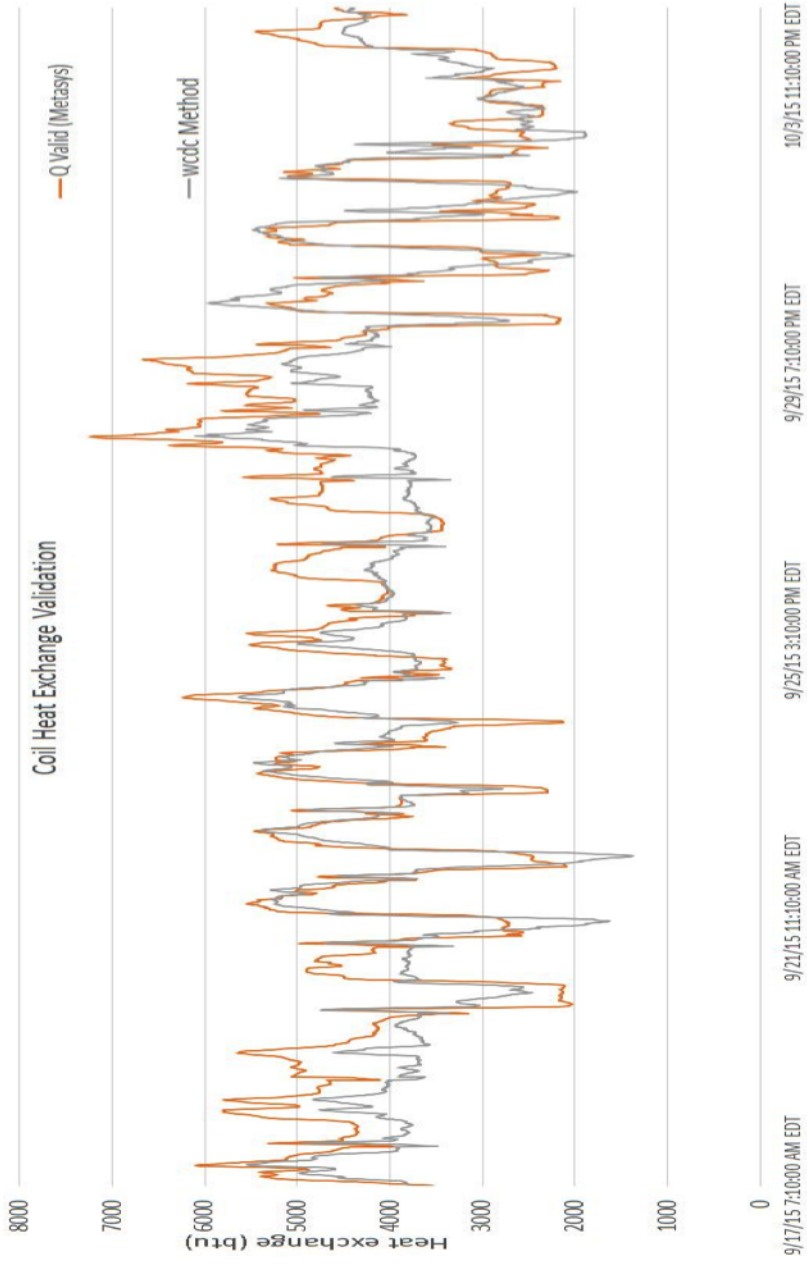

Fig. 6.1. Dry wet coil method heat exchange comparison

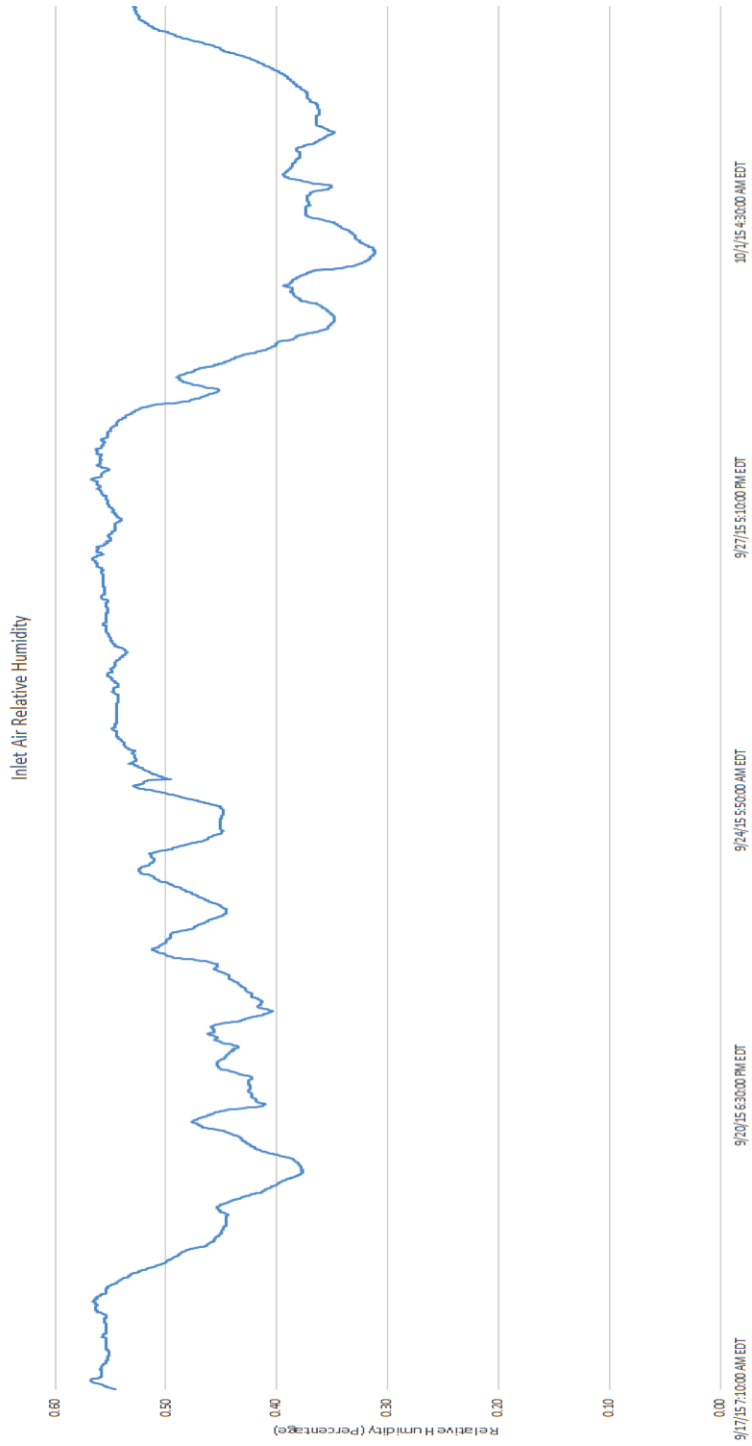

Fig. 6.2. Inlet air relative humidity

Figure 6.1 shows the comparison between wet dry coil model and experimental values in the coil heat exchanger. Figure 6.2 shows the relative air humidity during the analysis period. This figure shows how the wet coil dry coil analysis trend would change during the data analysis. Later this input data is used to explain the accuracy of each model. The modeling error and comparison in Figure 6.6 can be compared with inlet air relative humidity results from this section.

6.1.2 Enthalpy Based Effectiveness Model Validation

As it is shown in Figure 6.6 the comparison between enthalpy based effectiveness and also experimental values from Metasys software was calculated. The origin of experimental values equation and enthalpy based effectiveness is slightly closed since the enthalpy based effectiveness looks at the enthalpy values through energy balance. Experimental equations are based on input and output of building automation system but temperature wise.

As it was mentioned the enthalpy based effectiveness method is expected to have less error comparing it to experimental values. This also was discussed in Chapter 4. Generally, when there is a spike in experimental values it is harder for each model to get to spike value quickly but at the end the trends merge to the same values. Figure 6.3 shows less data variation and more actual data trend as it is shown in the most areas the trend matches between models. Later in next section the error between models are calculated and discussed in details, the trend in the model also was calculated using the moving average method calculation to make the data more smooth. Figure 6.3 also will be explained more in details in statistical analysis section.

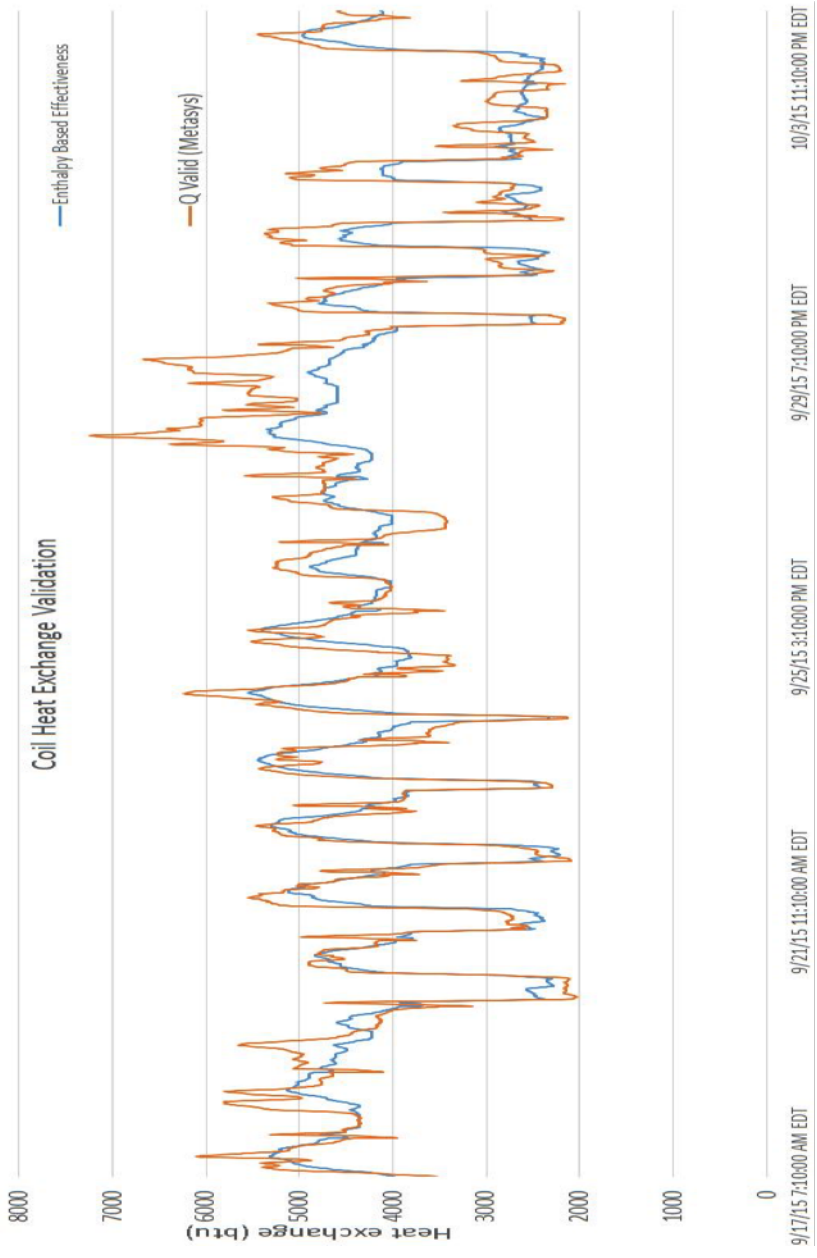

Fig. 6.3. Enthalpy based effectiveness method comparison

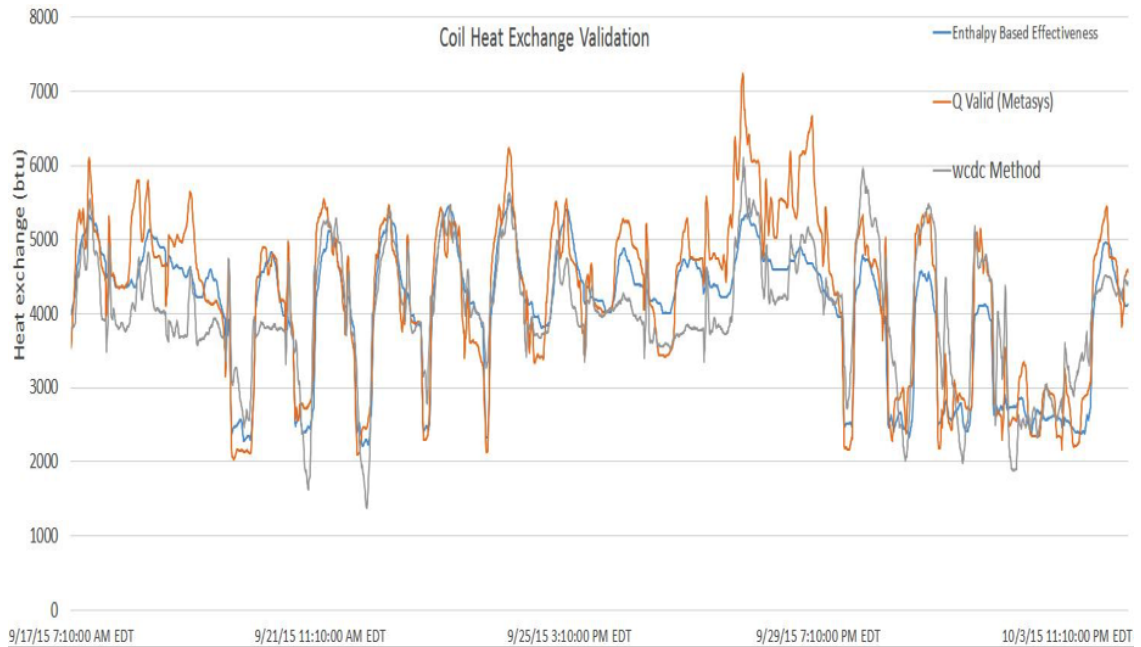

Fig. 6.4. Correlation between the trends for sub models (heat exchanger)

6.1.3 Heat Transfer Comparison Validation

Dry wet coil method and enthalpy based effectiveness both give us results that are close to the experimental values, but this section focuses more on the comparison for model results. Also the error for two methods was calculated and is explained in this section.

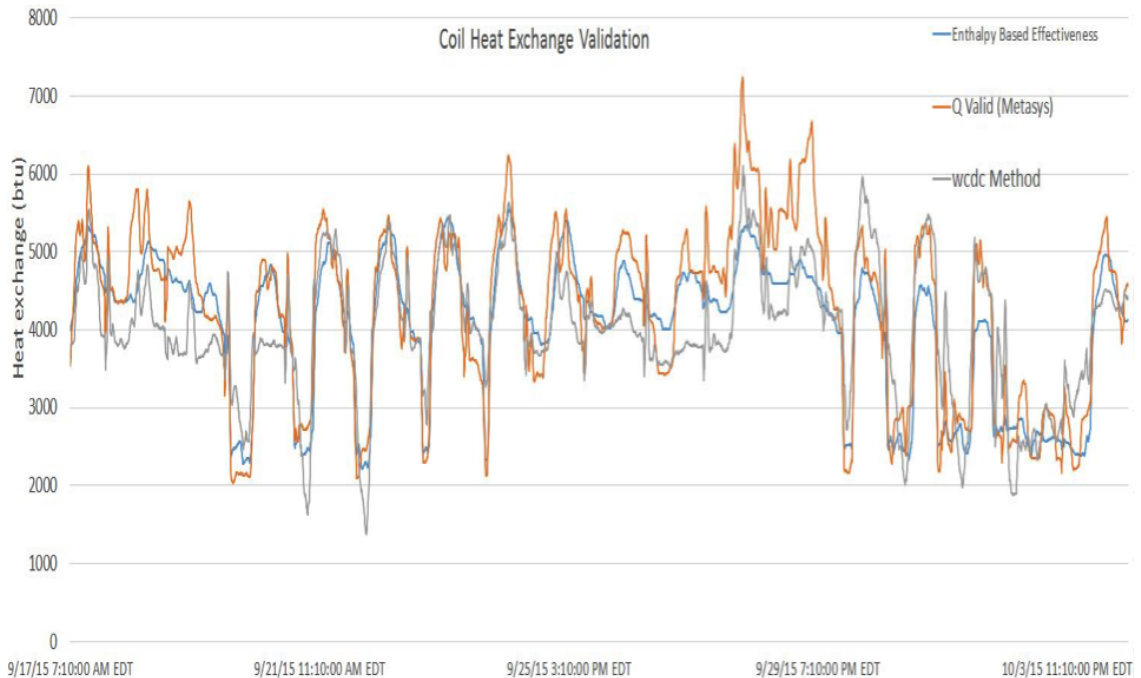

Fig. 6.5. Correlation between heat exchange values and model comparison

From Figure 6.4 it is obvious that two models have almost the same results as experimental values which are shown with orange color of called Q valid data. The error between two models also shows the difference of modeling and why there is a change between two models. Figure 6.6 shows the error between two models. Majority of the time this error values remain under 20%, but there are two highlighted areas showing that the consistency between two models is very low and unstable.

Most of the unreliability comes from wet dry coil method as this method is not suitable for the humidity values below fifty percent. In fact, in Figure 6.7 is shown whenever the two regions for relative humidity go below fifty percent. The dry coil method predicts the entire coil is dry. This assumption from wet dry coil method leads to more errors rather than enthalpy based effectiveness method.

Error Between "vdc vs enthalpy" Models

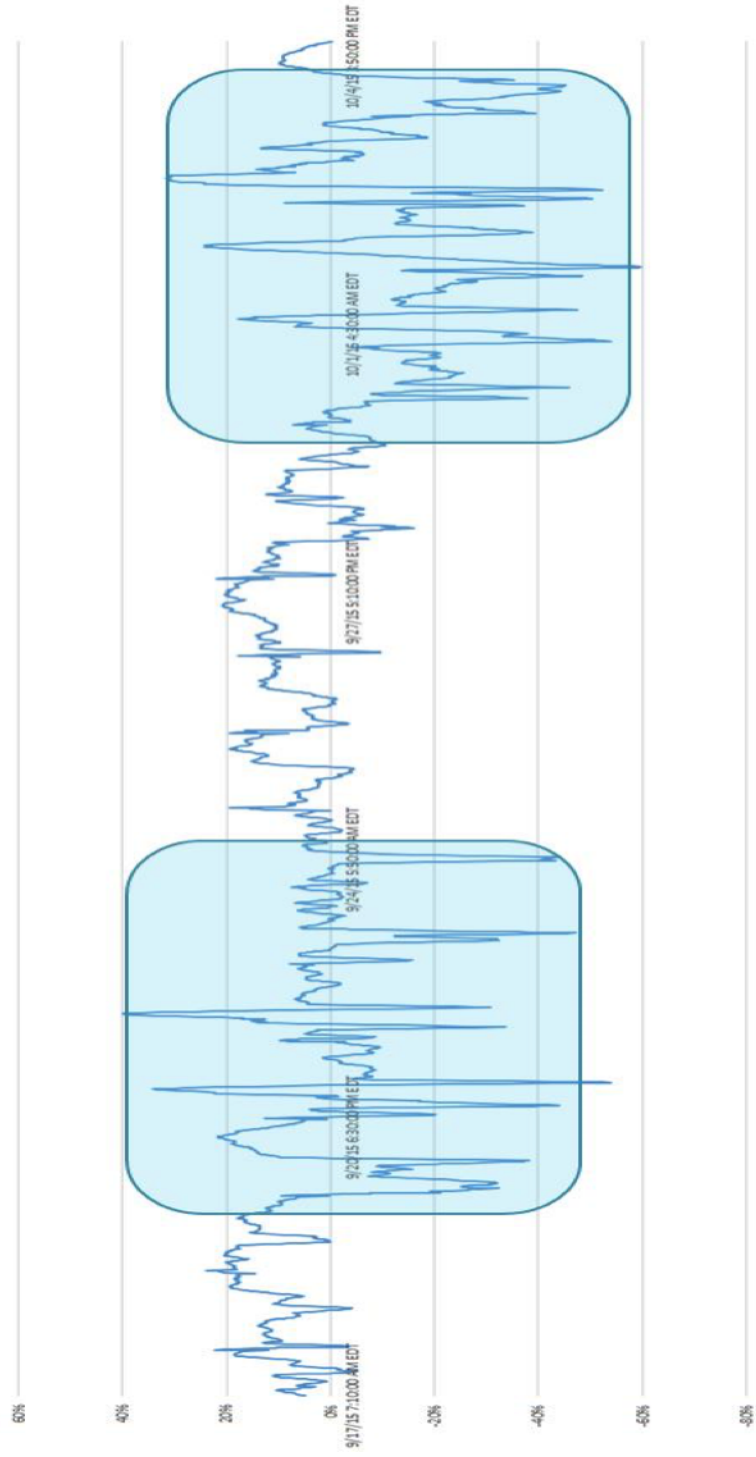

Fig. 6.6. Error between two models

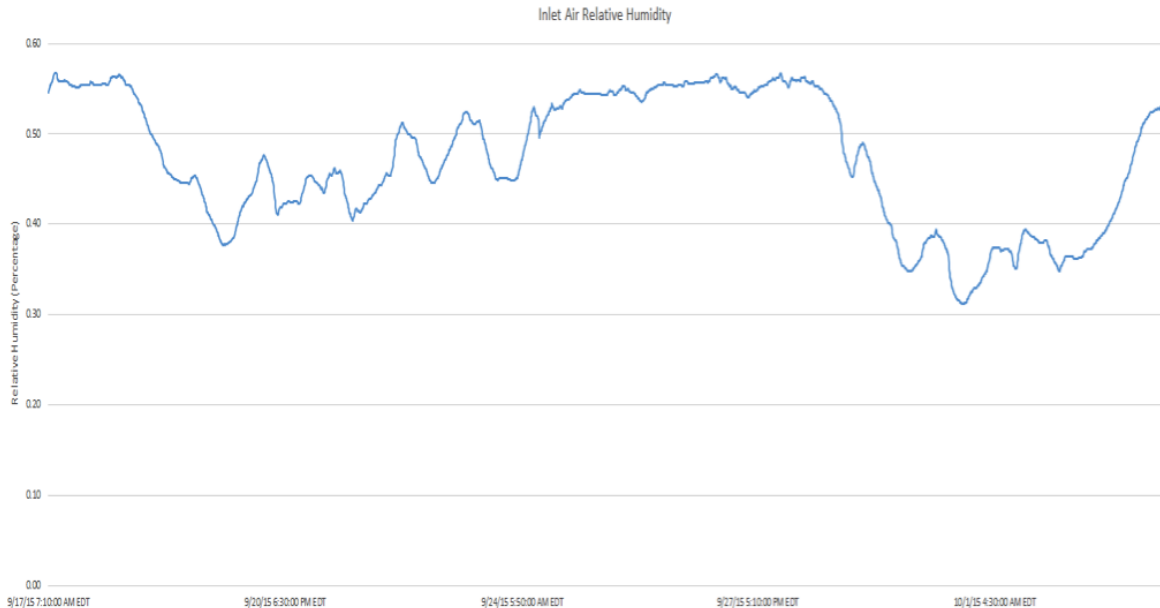

Fig. 6.7. Inlet air humidity

In fact [28] shows whenever we have less relative humidity through the coil there is more error between two models of dry wet coil and enthalpy based effectiveness. Also once we get to higher temperature, since there would be more heat transfer required these errors get to higher values.

Therefore, whenever we have higher values of relative humidity the wet dry coil method could be more valuable and useful since it will give us the details of information on separation dehumidification and reducing temperature. But enthalpy based effectiveness can give us more accurate results if the outside air is pretty dry already once it comes inside the air handling unit box. Table 6.2 includes information on results accuracy corresponding to each modeling. (errors less than 20% in modeling were marked as acceptable results)

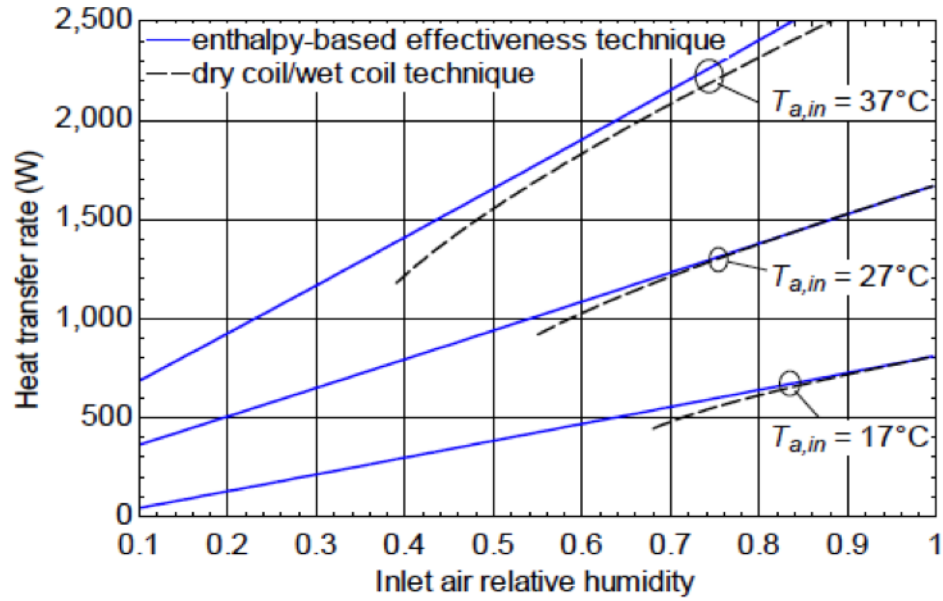

Fig. 6.8. Comparison of two models in various relative humidity and inlet temperature values [33]

Table 6.2.
Error difference between two models

Model	Humidity above 50%	Humidity below 50%
Dry Wet Coil Method	Acceptable results with details of dehumidification	Not accurate results for heat exchanger
Enthalpy based effectiveness	Acceptable results no details	Accurate results

6.2 Sensor Faults and Accuracy Research

Results and conclusions are made in this chapter based on the integrated model of heat exchanger sub model and also error comparisons discussions. There were different time periods for data collections as there were two different models discussed in this

research. Data for the modeling validations was basically from September 17 through October 4, 2015.

Almost a month of data was collected to validate each heat transfer model comparing to experimental values which were calculated through the Metasys software and building automation system. Sensor information also was collected and investigated though this time period to make sure there are valid results available for the models.

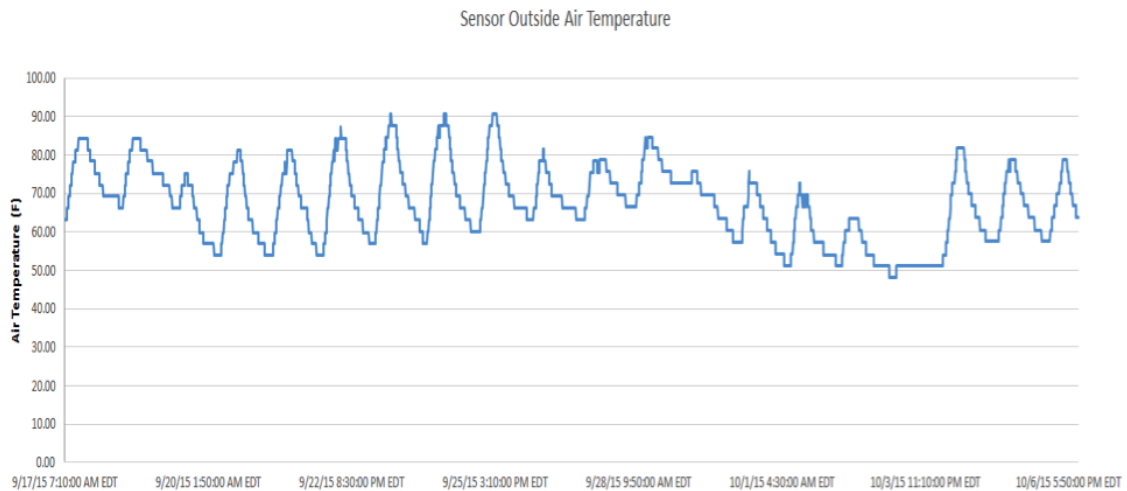

Fig. 6.9. Outside air temperature sensor data

Figure 6.9 shows the data for outside air temperature. Initially this information was gathered through September 17 and October 4, 2015 just to make sure data is valid from the sensors. Later on, as it is shown on the graph one day in October temperature data had a flat line. So the performance of the sensors was under investigation. Figure 6.10 shows investigation to see if the outside air temperature sensor was functioning right. As a matter of fact, the weather data on that day was abnormal from the

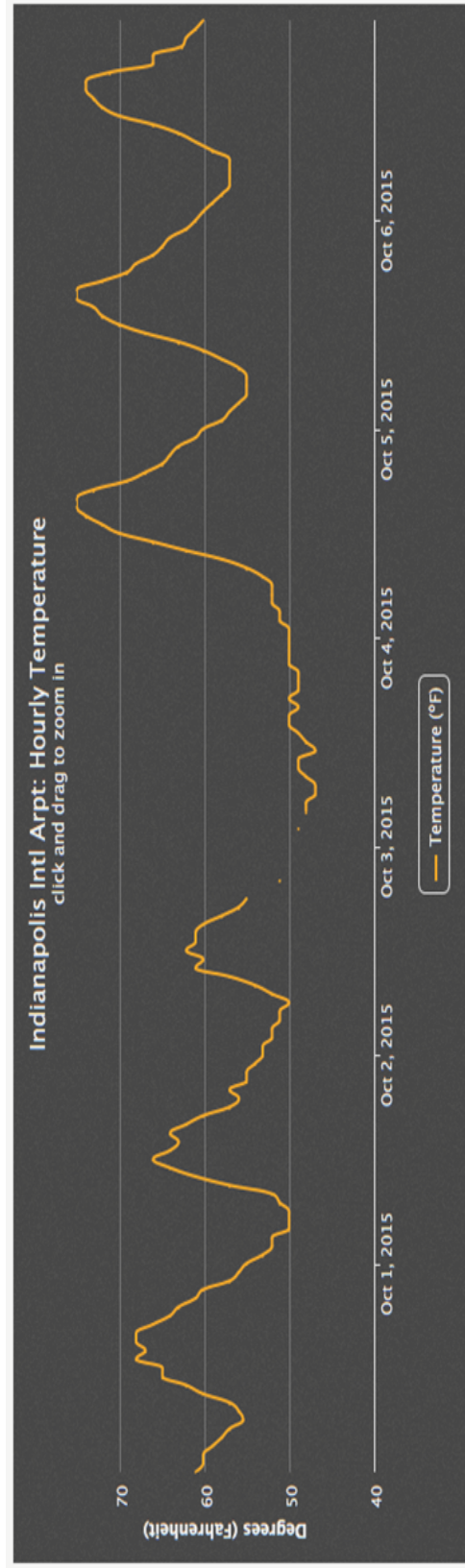

Fig. 6.10. Outside air temperature Indianapolis airport data [38]

reference Figure 6.10 [38]. So the result from out temperature sensors was trusted for the time period of data collection.

Later on, the air flow sensor was investigated to see the right functioning over the same amount of time: September 17 and October 4, 2015. But, as the Figure 6.3 shows there are couple of spikes in the data collection. This was researched and also discussed with building personnel to see why such error occurs for the sensors. In fact, sensors have auto reset and once a day the values from the sensor gets rest so there only one dataset everyday which gives us wrong values. Later on, this data fault was suggested to be removed from input data to the modeling. Moreover, in statistical analysis chapter discusses ways to smooth the data and make it more readable or valuable for model comparison.

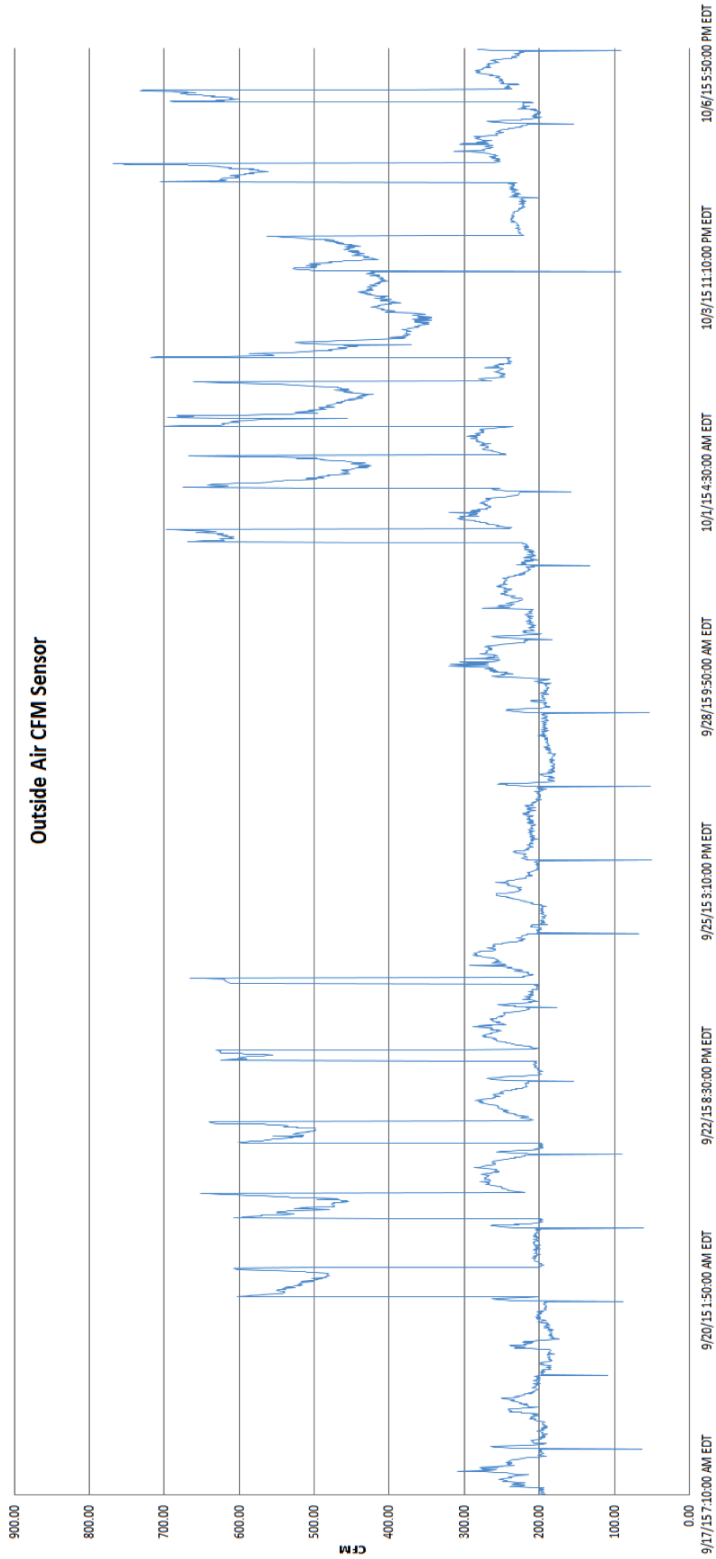

Fig. 6.11. Outside CFM sensor

6.3 Ventilation Energy Model Validation

There are many studies focused on air qualities inside buildings. Fresh air allows people to work more efficiently and stay healthy. Regarding the importance of air qualities in schools, studies show students spend on average of 12% of their time in schools more than any other buildings. Also other researches such as [37,39–43] have shown that many buildings have indoor air quality problems.

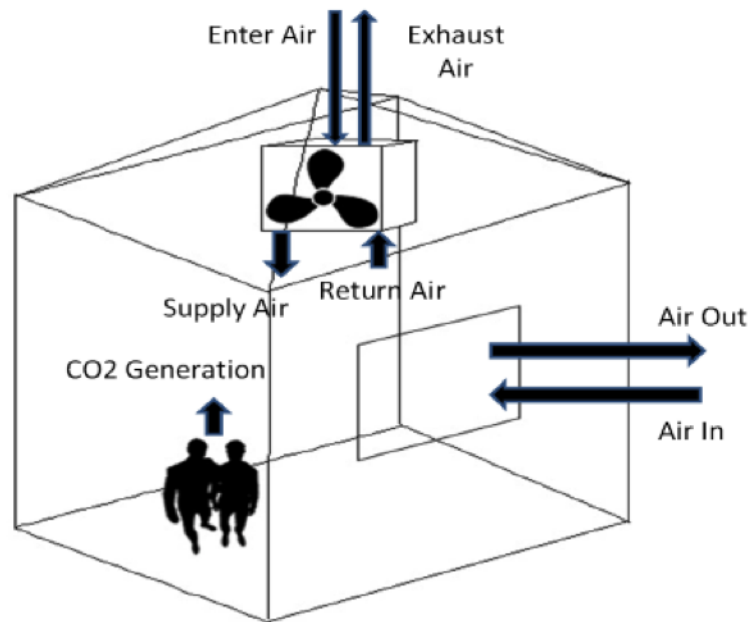

Fig. 6.12. Air ventilation inside building [39]

Such studies show the importance of having a good model for better air quality. Organizations such as American Society of Heating Refrigeration and Air Conditioning (ASHRAE) have defined a rules and limits for the CO_2 values inside the buildings. “ASHRAE 62.1” focuses on CO_2 levels that mentions typical outside air CO_2 level is around 380ppm. ASHRAE maximum target for indoor CO_2 value is at 650ppm. So this rule defines above 1,030ppm CO_2 is dangerous breathing condition that buildings

should avoid to reach to that level. Also other references have set values for CO_2 levels what is called as Normal CO_2 levels. Table 6.3 has listed CO_2 normal operating ranges. This research has used this CO_2 settings range in order to find a model for

Table 6.3.
Normal CO_2 levels

Condition	CO_2 Values
Normal Outdoor Level	350-450 ppm
Acceptable levels	Higher than 600 ppm
Complaints of stiffness and odors	600 to 1000 ppm
ASHRAE and OSHA standards	1000 ppm
General drowsiness	1000 to 2500 ppm
Adverse health effects expected	2500 to 5000 ppm
Maximum allowed concentration within 8 hours working period	5000 ppm

the fan inside current test building. Currently, this fan is running all the time since there is no way of measurement for how much fresh air is needed inside the building. Also the cost calculations have been done at the end of this research and impact of having a good model controller on energy savings. Figure 6.13 also shows the data was collected in the basement area for the whole week in October 2015.

Table 6.4.
 CO_2 data collection

Data Set	Time Period	Sampling Time	Number of Samples
CO_2	10/04/2015 to 10/11/2015	7 Days	1010

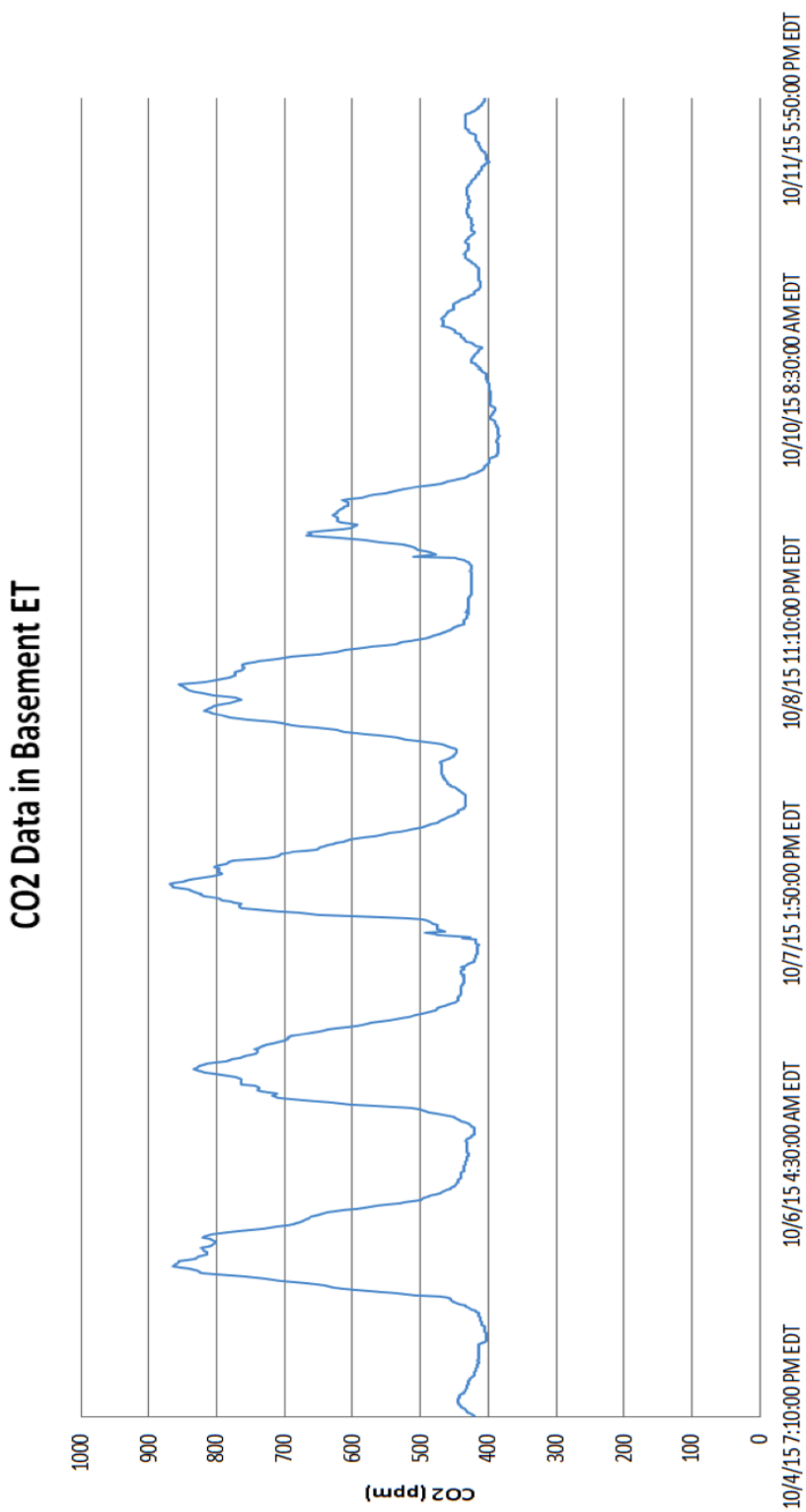

Fig. 6.13. CO₂ values for the week of data collection in the test building

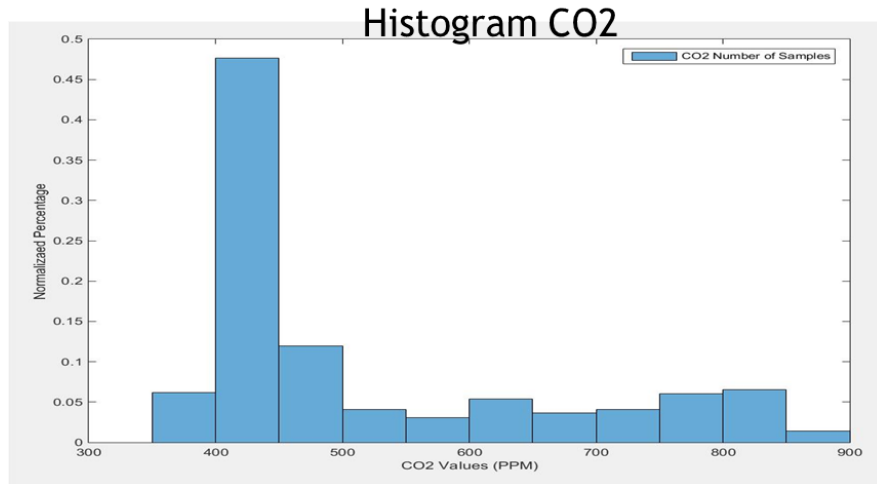

Fig. 6.14. CO_2 histogram for ppm values during week of data.

As it is shown in the graph above, the CO_2 values go up during weekdays almost for 5 peaks since specially this is the week of classes. As you can see the CO_2 values for these days are almost reaching to the limit that was set by ASHRAE standards. This tells us that more ventilation is required during this time of the week. Also, at the end of Figure 6.13 it is clearly seen that CO_2 values are pretty low and they are below 500 ppm. That's where no ventilation is required and energy savings can be made by using intelligent model and controller for this kind of building.

6.3.1 Fan Discrete ON/OFF Output Method

Closer look at the data in Figure 6.13 shows that most of the time the CO_2 values are not higher than limits in fact almost 50 percent of the time these values are below 500ppm. Figure 6.14 shows the histogram of CO_2 values , where the x-axis shows the ppm values and y-axis shows the normalized percentage number of samples. Blue bars are percentage values corresponding to CO_2 ppm.

A model has been made using Matlab codes to show when the fan should be on to reduce the CO_2 values and increase the ventilation. Thus, this model is working on Comfortable Air Level parameter.

$$ComfortAirLevel = 1 - \frac{(CO_2 - CO_2Desired)}{CO_2Desired} \quad (6.1)$$

Comfort air level consists of experimental CO_2 values, which is named as CO_2 in the model. Also CO_2 desired value that is set as a threshold for the air handling unit fans. Using this parameter a Matlab code and a for loop was designed to automatically read the CO_2 values from the sensors.

$$CO_2Values > CO_2Desired \quad (6.2)$$

$$CO_2Values < CO_2Desired \quad (6.3)$$

In a for Loop

$$ComfortAirLevel = 1 - \frac{(CO_2 - CO_2Desired)}{CO_2Desired} \quad (6.4)$$

For Calculating the fan power, the for loop calculates the comfort air level for each data set and also sets the fan power to the value 0 or 1, meaning that if air level is not 100% the value for fan power should be equal to fan running value. Also, if the comfort air level is at 100% the fan power should be equal to zero, meaning that fan should be off and ventilation is not needed.

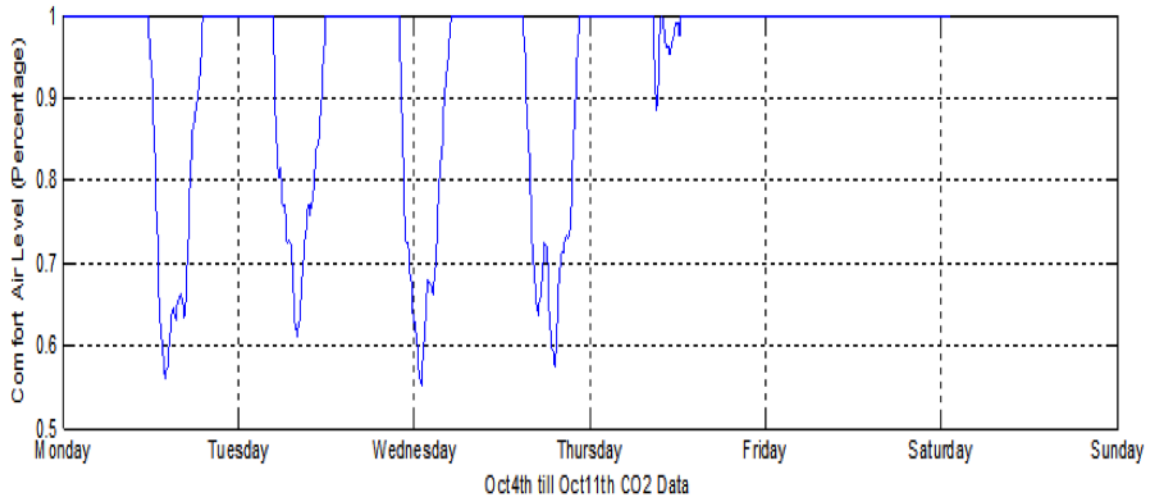

Fig. 6.15. Fan model for corresponding comfort air levels

Example presented in Figure 6.15 shows the percentage of air comfort level data during October 4 until October 11. This figure suggests that most of the time we have 100% comfort air level. Meaning that most of the time the CO_2 level inside the building is below our limit and threshold. In this example the CO_2 threshold was set at 600ppm.

6.4 Fan Continues Output (Controller) Method

Previous method or what is called ON/OFF method is a good modeling strategy that gives us control on the system and eventually energy savings on power outputs. But previous method also had few issues and problems. The ON/OFF method is a discrete controller, so overall ventilation performance and ventilation rate cannot be vary continuously. Also, the other problem is that in order to provide better air comfort level the discrete system will keep the fan most of the time running with higher cost of energy. So, the goal of this section is to control the system,

find a balance between air comfort quality and the power consumption. Intelligent controller was introduced in this section of research in order to provide better system performance and control. As it was discussed in Chapter 5, fuzzy logic controller consists of membership functions, which was defined for this specific AHU system and Figures 6.16 and 6.17 show how this membership functions are set for this fuzzy logic controller. Input membership functions are shown in Figure 6.16. There are 5 scenarios in this section explained for the outputs that are driven by inputs.

Moreover, Figure 6.17 shows the controller output actions and corresponding values for power output. This scenario is for the current fan, which has 4kW of power. There is a rule in the power output fan that always keeps the minimum power of 10% running. This action is required to make the flow inside the duct and have the minimum static pressure to keep in air handling unit.

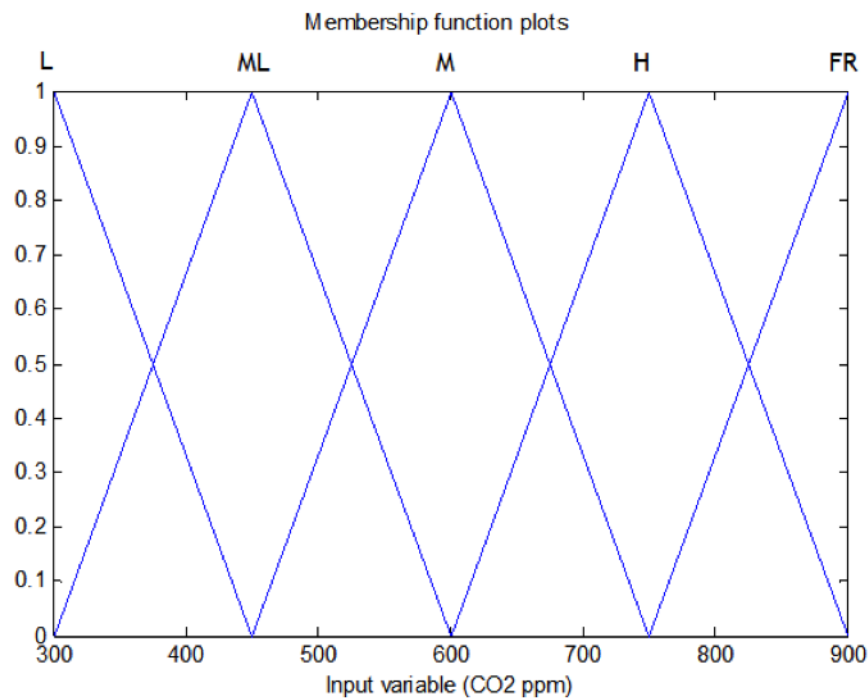

Fig. 6.16. Fuzzy logic controller input membership functions

Table 6.5.
Input membership actions

CO_2 (ppm)	Corresponding Action
300 - 450	Low
450 - 600	Medium Low
600 - 750	Medium
750 - 900	High
Greater or Equal than 900	Full Run

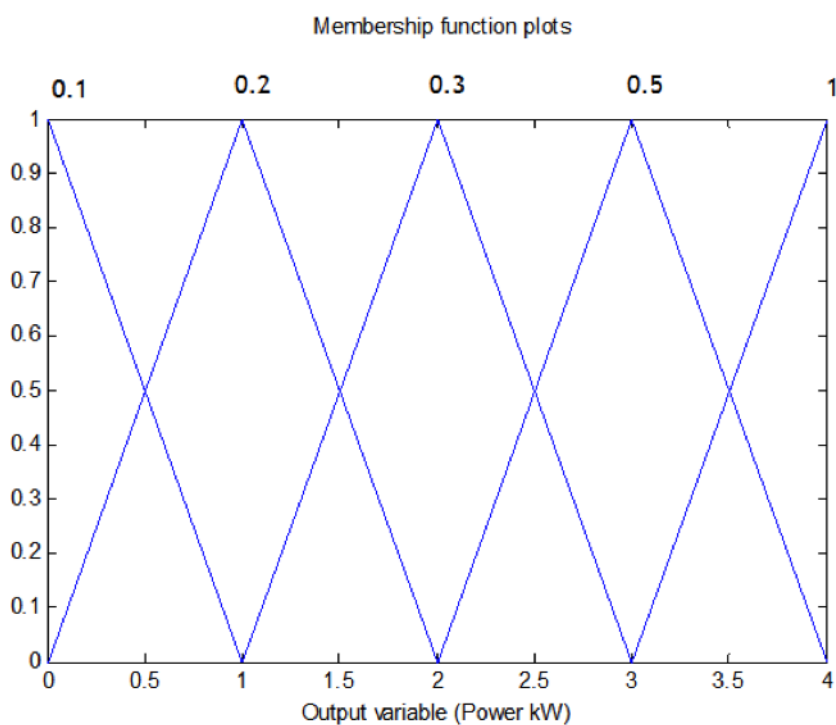

Fig. 6.17. Fuzzy logic controller output membership functions

Also the rule view for the fuzzy interface system is shown through Figures 18 to 22. Figure 6.18 shows how the input of 448 ppm will be translated in fuzzy logic controller

Table 6.6.
Input membership actions

Fan Output Power (kW)	Corresponding Running Percentage
0 - 1	%10
1 - 2	%20
2 - 3	%30
3 - 4	%50
Greater or Equal than 4	%100

to the output of 1kW. Figure 6.19 shows how the input of 602 ppm will be translated in fuzzy logic controller to the output of 2.02 kW. Figure 6.20 shows how the input of 843 ppm will be translated in fuzzy logic controller to the output of 3.2kW.

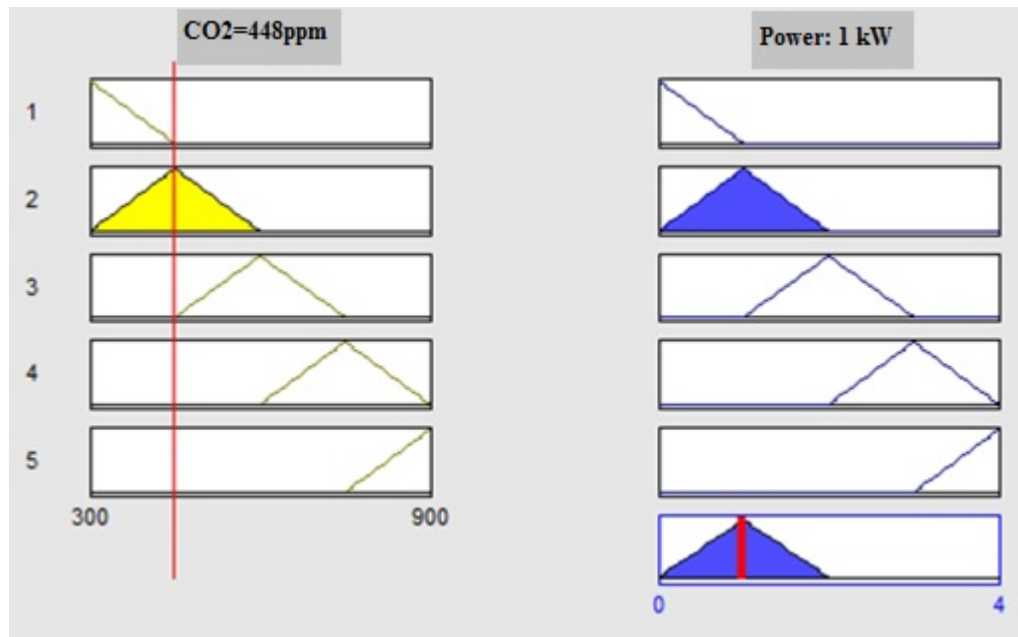

Fig. 6.18. Rule view for fuzzy interface system 448ppm ex (Simulink)

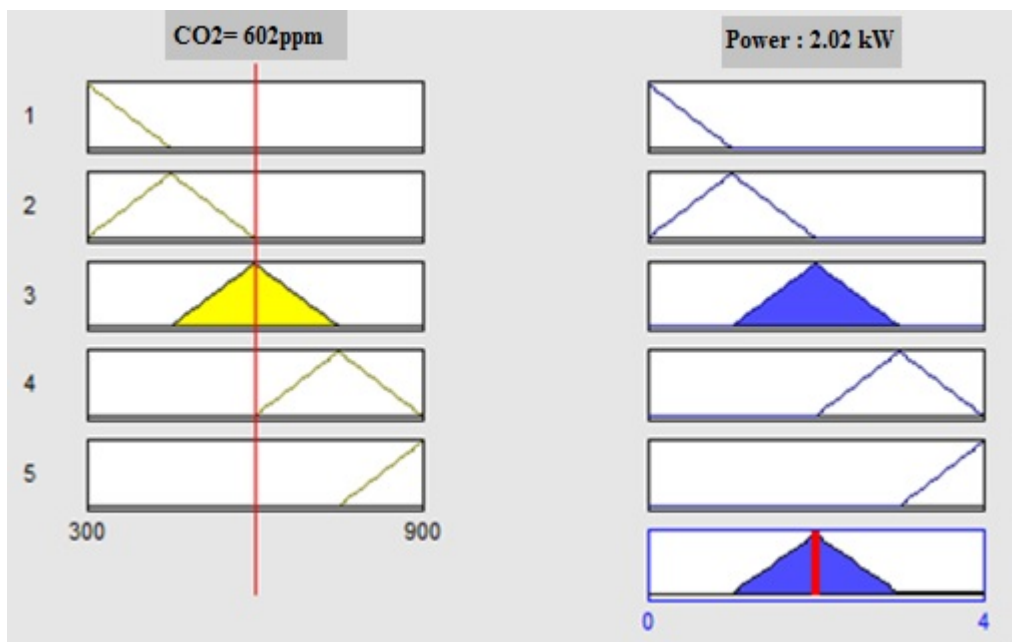

Fig. 6.19. Rule view for fuzzy interface system 602ppm ex (Simulink)

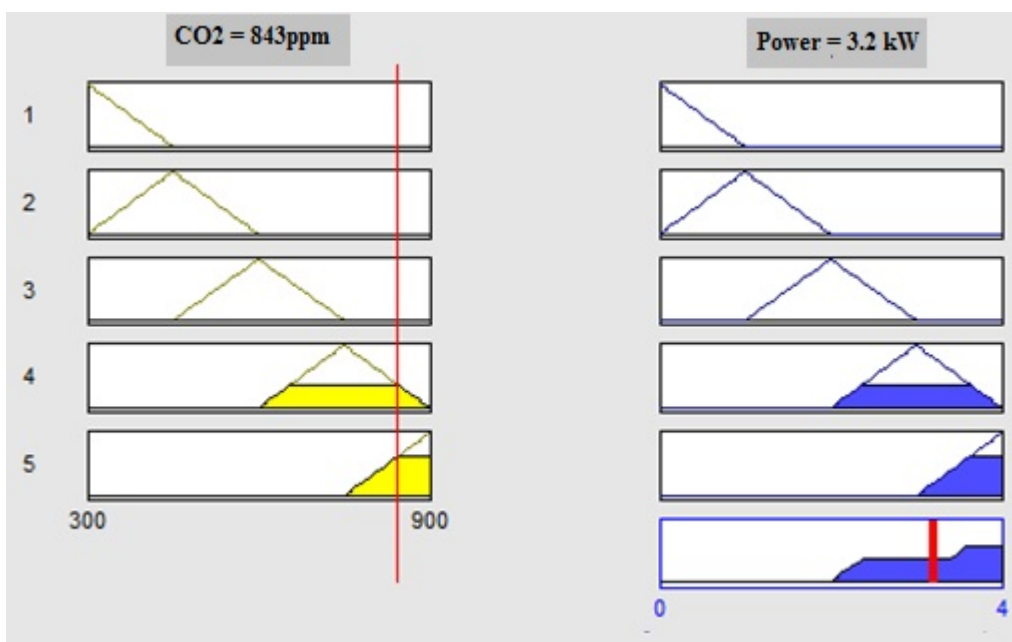

Fig. 6.20. Rule view for fuzzy interface system 843ppm ex (Simulink)

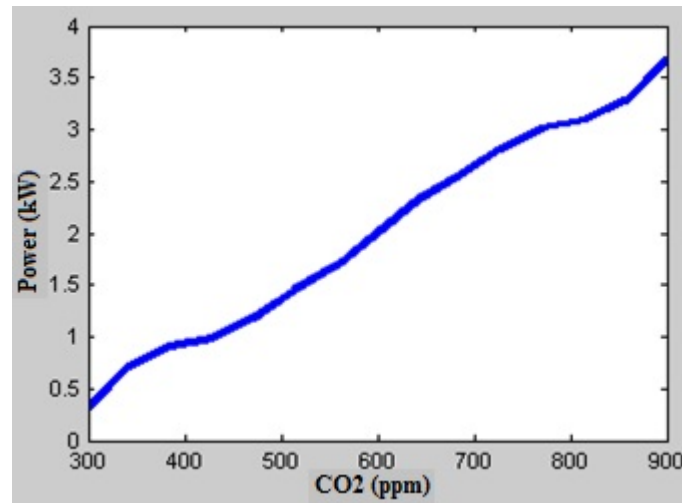

Fig. 6.21. Fuzzy logic controller continuous correlation between Inputs/Outputs

In the end, Figure 6.21 shows how fuzzy logic interface system translates the inputs as CO₂ ppm values to the output of air handling unit as a power output (kW) for the system. This method allows us to get better values and optimization on the power output instead of having a discrete ON/OFF values. Also finding the optimal point for the fan running is another advantage of running this type of controller.

7. CONTROL STRATEGY OPTIMIZATION RESULTS

In Chapter 6 two different methods were discussed for modelling of air handling unit power outputs. Each method has advantages and disadvantages, so this section is dedicated to show how the controls for the air handling unit were optimized.

7.1 Discrete Fan Output Energy Reductions (ON/OFF)

ON/OFF method was used to control the fan output instead of having it run all the time. As it was discussed in Chapter 6, this method is based on comfort air level, which is the top graph in Figure 7.1.

Figure 7.1 also shows the power output required to start the ventilation, when comfort air level is not at a good point. The power output in this section was measured based on the rule that whenever the comfort air level is below 100% the fan should be on and actually equal to 1; as soon as we have 100% comfort air level the fan can go off. This method has some disadvantages as it was discussed in Chapter 6. Better controls were needed to calculate this power, since minimum power required to keep the static pressure inside the duct positive. Also, gradual speed for increasing and decreasing the fan power is more logical, since it will reduce the cost of maintenance on the fan.

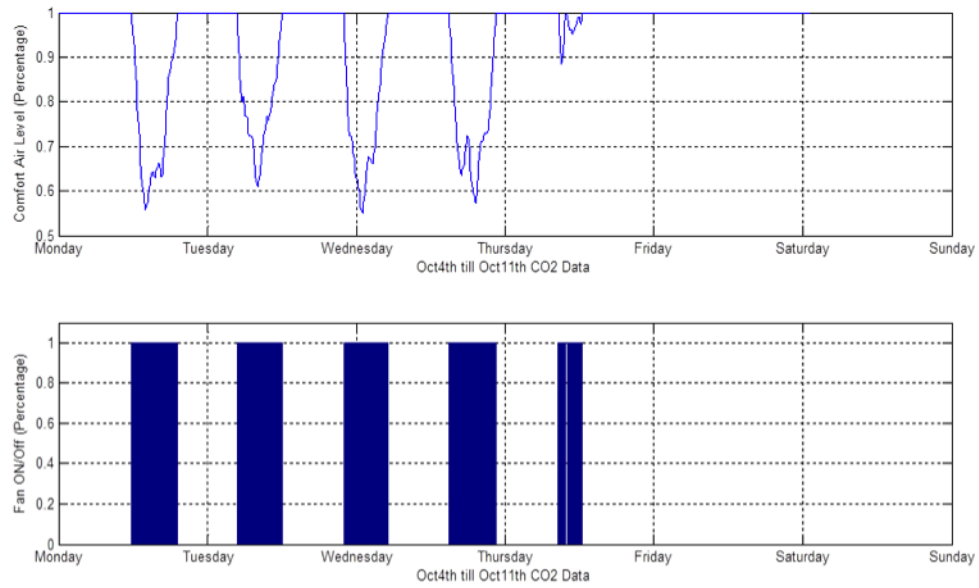

Fig. 7.1. On/Off method modeling

7.2 Continuous Fan Output Energy Reductions (Fuzzy Logic)

On the other side the output power was calculated using the continuous calculations and fuzzy logic controller to give the best performance to the system as well as energy reduction on the fan. Figure numbers 7.2 and 7.3 show the system performance using Simulink, Matlab, and fuzzy logic controller method.

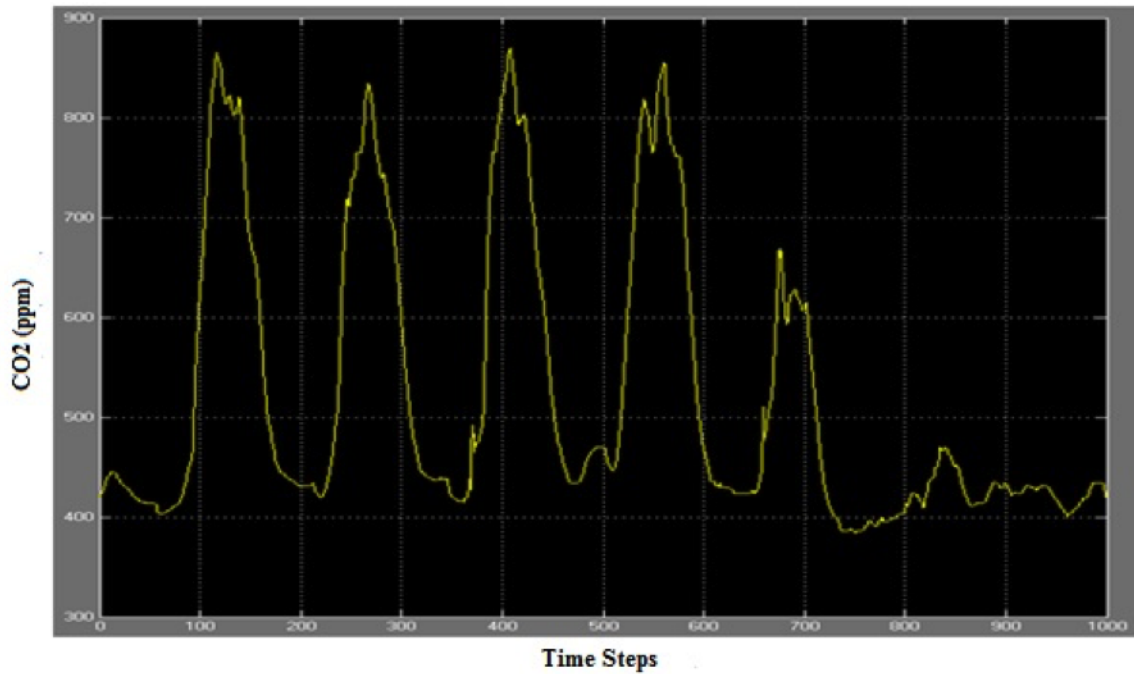

Fig. 7.2. Simulink scope input CO2 data (Simulink)

Figures 7.2 and 7.3 are scopes from Simulink tool. Figure 7.3 shows the power output of the system based on percentage (values from 0 to 1). As its shown, the output of the fuzzy logic controller for the current data set is more robust and optimized. The fan always keeps the minimum power running, so there is always flow in the duct and positive pressure. Also, this method is very responsive and fast to any change in CO_2 values. Comparing Figures 7.2 and 7.3 it can be seen that both Simulink scopes have the same trend meaning that controller completely follows the consistency of input data.

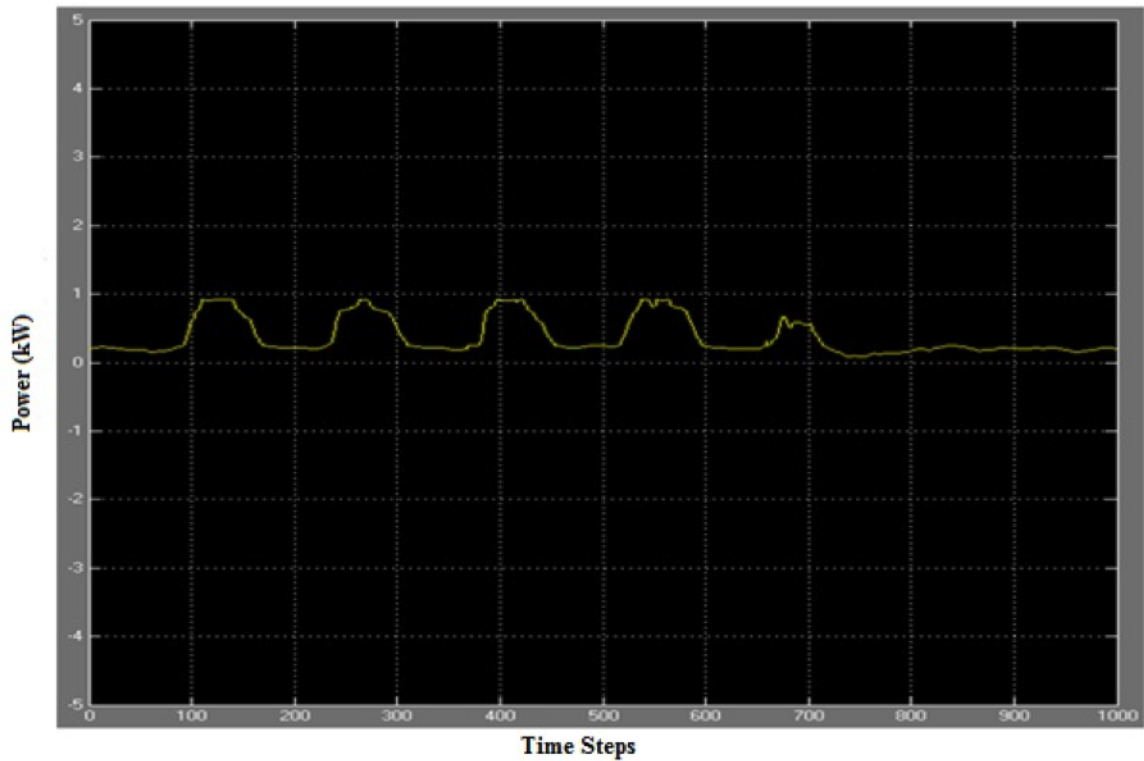

Fig. 7.3. Simulink scope output power (Simulink)

7.3 Potential Energy Savings

Energy savings in both methods have been analyzed. Comparisons have been shown in Figure 7.4. ON/OFF method has a blue color and fuzzy logic controller is shown with red. The fact that ON/OFF method will keep the fan off most of the time may be an advantage for the method, but in long term period it will be a problem for most of air handling units, since the pressure inside the duct would decrease significantly.

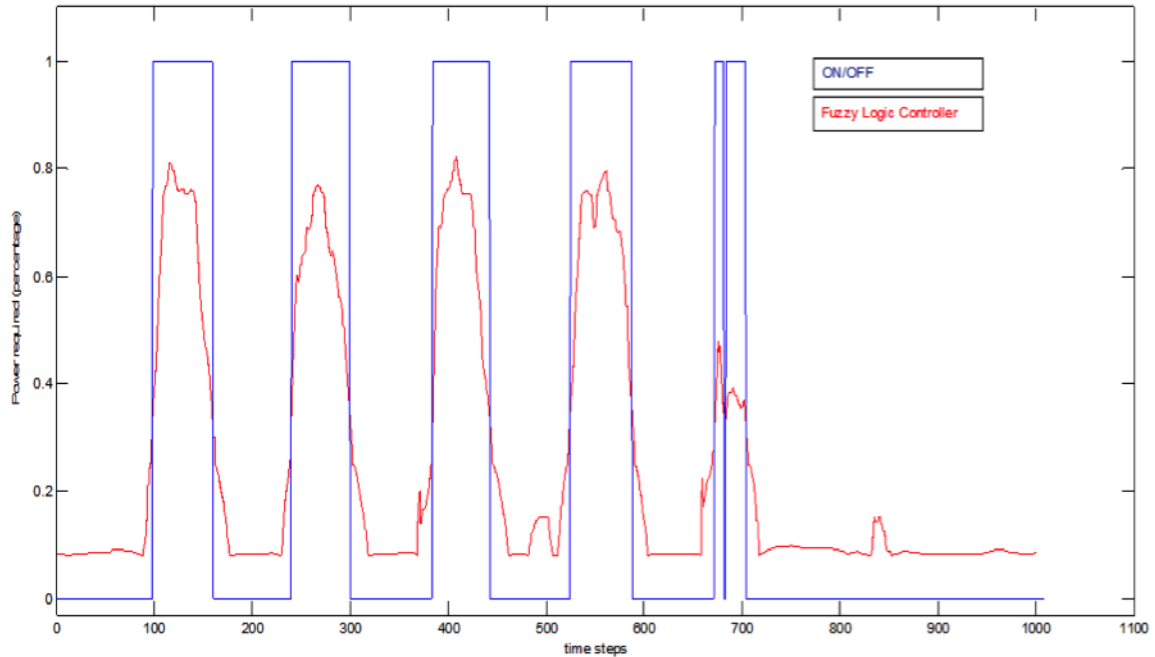

Fig. 7.4. Two controlling methods comparison

The savings were calculated corresponding to each method comparing with the current practice that is having the fan always running, which is the case in this building for ventilation purposes.

Table 7.1.
Energy reduction data collection

Data Set	Time Period	Sampling Time	Number of Samples
CO_2	10/04/2015 to 10/11/2015	7 Days	1010

Since the data was collected weekly, the baseline for the savings also set on a weekly basis. Table 8.2 demonstrates how much each method can save during week of October. Basically this percentage numbers in Table 8.2 are from comparing the

Table 7.2.
Energy reduction comparison ON/OFF and fuzzy logic controller

Simulation	ON/OFF method	Fuzzy Logic Controller
Power Reduction Percentage	72.94%	62.79%
Weekly Energy Reduction	490 kWh	422 kWh

total fan running time during the whole week. Table 8.2 in second row represents savings calculated by the energy reduction on the Fan. As it was mentioned before, the current power for the fan running in the air handling unit system is 4 kW. ON/OFF method has more savings; however, this method will bring more maintenance cost and reduce the life time of the fans. Also, air handling unit requires positive static pressure inside the duct. This condition can be met with fuzzy logic controller at all times. For other type of air handling units that have only one fan the ON/Off method can be more useful. If fuzzy logic method is used to simulate the power for VAV air boxes then ON/OFF method still has more advantages, but for bigger operations like air handling units based on this research the fuzzy logic method is preferred.

8. CONCLUSIONS AND RECOMMENDATIONS

8.1 Conclusion for Air Handling Unit Modeling

This thesis is mainly focused on energy efficiency and energy reduction in the buildings. The modeling was done to achieve better monitoring the energy usage and also control the building air handling unit subsystems efficiently. In air handling unit there were two models explained, defined, and modeled using thermodynamic equations and software modeling. Dry wet coil model and enthalpy effectiveness models were also validated comparing to experimental values from the units. Statistical analysis has been done to make the data smoother and more readable. After comparing two models it was concluded, enthalpy based on effectiveness provide less accurate results. Wet dry coil method is more complex analysis considering different regions on the coils but it gives more information on dehumidification and physical system parameters, this would help to estimate the system behavior in more detailed manner.

From the deviation analysis, the reason why two models in some regions have big gaps is mostly because when outside air is already dry, the wet dry coil method does not perform as accurately as enthalpy based effectiveness. So its recommended to use wet dry coil method in humid regions and enthalpy based effectiveness mostly in dry regions. Performance of dry/wet coil in general is higher in our test case. Considering current test case in this research dry wet coil method can be a better fit to show the system performance and more accurate simulations. This accurate modeling helps with energy reduction by estimating the system behavior. Also, fouling and resistance analysis can be an indicator of how our air handling unit performs in general through its lifetime or if any maintenance is needed.

8.2 Conclusion for Fan Power Controller

In the conclusion, CO_2 analysis and modeling have been done based on wireless data collection. There were two control methods/models described and compared for system power output. The fuzzy logic controller for air handling units has better control performance but less energy reductions. The ON/OFF method has more energy loss but less complicated system as it does not require complex control algorithms comparing to fuzzy logic method. The ON/OFF method would be more suitable for smaller applications, such as single fan HVAC units or VAV boxes inside the building. The fuzzy logic controller would give a better system performance on the whole air handling units. Fuzzy logic controller made energy reduction of 62% for the fan power on the current system, while ON/OFF method made 73% of energy reduction. But its proven for the purpose of this research based on the current condition of air handling unit the fuzzy logic controller is a better fit with better system performance.

8.3 Recommendations for Future

8.3.1 Control Implementations

Implementing the current strategy and controls on the air handling unit can be a huge milestone and improvement of current system performance. Based on analysis and theoretical data, the fuzzy logic controller would be a great energy optimization method.

8.3.2 Powerful and Faster Wireless Communication System

As it was discussed, current wireless system has a lot of limitations due to the outdated technology used during the research. There are many other products on the market for wireless communication that can enhance the speed of current project and ease the process of data collection.

LIST OF REFERENCES

LIST OF REFERENCES

- [1] DOE, “Energy efficiency trends in residential and commercial buildings,” *US Department of Energy*, 2010.
- [2] T. Yau, “On-line control strategy of fresh air to meet the requirement of iaq in office buildings,” *Proc. IEEE Conf. on Industrial Electronics and Applications*, Taiwan. June 2010.
- [3] G. Alex, “Estimating occupancy using indoor carbon dioxide concentrations only in an office building: a method and qualitative assessment,” *Energy and Environment Department, CSTB*.
- [4] E. George, “Advanced thermodynamic analyses of energy intensive building mechanical systems,” *RIT scholars Works*, 2006.
- [5] M. Reichler, “Modeling of rooftop packaged air conditioning equipment,” *University of Wisconsin-Madison*, 1999.
- [6] A. Abdul and F. Sharifi, “American society of heating refrigerating and air-conditioning engineers, 2009 ashrae handbook fundamentals (i-p edition),” *ASHRAE*, 2009.
- [7] A. Abdul, “Review of modeling methods for hvac systems,” *Applied Thermal Engineering*, pp. 507–519, 2014.
- [8] F. Haghigat, “A software framework for model predictive control with genopt,” *Elsevier*, vol. 42, pp. 1084–1092, January 2010.
- [9] H. Kim, “Methodology for rating a building’s overall performance based on the ashrae/cibse/usgbc performance measurement protocols for commercial buildings,” *Texas AM*, December 2012.
- [10] M. R. Bible, “Modeling building energy use and hvac efficiency improvements in extreme hot and humid regions,” *Texas AM*, October 2011.
- [11] P. Yin, “Modeling of ecm controlled series fan-powered vav terminal units,” *Texas AM*, October 2010.
- [12] DOE. Us department of energy - software developed and provided by usa doe [note: last accessed 18-feb-2016]. [Online]. Available: <http://www.doe2.com/>
- [13] C. HVAC. Hvac comissioning information, mixing box chapter [note: last accessed 18-feb-2016]. [Online]. Available: <http://www.commissioninghvac.org/files/dlib/mixingbox.pdf>

- [14] S. Genius. Software testing, compariosn among black box and white box tests [note: last accessed 18-feb-2016]. [Online]. Available: <http://www.softwaretestinggenius.com/photos/wbtut1.JPG>
- [15] T. Bourhan and M. Molhim, "Dynamic model of an hvac system for control analysis," *Energy 30*, vol. 10, pp. 1729–1745, 2005.
- [16] K. Fong, V. Hanby, and T. Chow, "Hvac system optimization for energy management by evolutionary programming," *Energy and Buildings*, vol. 38, pp. 220–231, 2006.
- [17] S. Workshop. Simulation tools for building more efficient environment [note: last accessed 18-feb-2016]. [Online]. Available: <http://sustainabilityworkshop.autodesk.com>
- [18] M. Tobias, M. Fischer, and V. Bazjanac, "Building energy performance simulation tools-a life-cycle and interoperable perspective," *Center for Integrated Facility Engineering (CIFE) Working Paper*, vol. 107, pp. 1–49, 2007.
- [19] L. Pengfei, "Recent advances in dynamic modeling of hvac equipment part 2: Modelica-based modeling," *HVAC Research*, vol. 20, no. 1, pp. 150–161, 2014.
- [20] T. Molhim and M. AlRousan, "Dynamic model of an hvac system for control analysis," *Energy 30*, vol. 1, pp. 1729–45, 2005.
- [21] Z. Michelsen and F. Bery, "Control design and dynamic simulation of an hmr pre-combustion power cycle based on economic measures," *Energy*, vol. 51, pp. 171–83, 2013.
- [22] R. Z. Homod, "Assessment regarding energy saving and decoupling for different ahu (air handling unit) and control strategies in the hot-humid climatic region of iraq," *Science Direct*, vol. 74, no. 1, pp. 762–774, January 2014.
- [23] P. Dormy and A. Guilines, "Guilines for the tuning and the valuation of decen-trazlied and decoupling controllers for process with recirculation," *ISA TRANS*, vol. 40, pp. 341–51, 2001.
- [24] T. Griffin and F. PJ, "Tuning of decentralized pi (pid) controllers for tito pro-cesses," *Control Eng Pract*, vol. 14, pp. 1069–80, 2006.
- [25] J. Li, "Modeling and optimization strategies of an air handling unit on campus," *Master thesis school of engineering and technology IUPUI*, May 2015.
- [26] E. E. Solver. Information on ees software [note: last accessed 18-feb-2016]. [Online]. Available: <http://www.fchart.com>
- [27] Energyfool. Savings and payback on energy efficient systmes [note: last accessed 18-feb-2016]. [Online]. Available: <http://www.energyfool.com>
- [28] G. Nellis and S. Klein, *Heat Transfer*. Cambridge, December 2008.
- [29] B. etal, "Hydrologic variability of the cosumnes river floodplain (," *San Francisco Estuary and Watershed Science*, vol. 4, no. 2, 2006.
- [30] Y. Chou, "Statistical analysis," *Holt International*, no. ISBN 0-03-089422-0 section 17.9, 1975.

- [31] A. Savitzky and M. Golay, "Smoothing and differentiation of data by simplified least squares procedures," *Analytical Chemistry*, vol. 36, no. 8, pp. 1627–39, 1964.
- [32] A. G. Khatib, "Using wireless monitoring systems to evaluate performance of an air handling unit in a commercial building and validating the mechanical model," *Master thesis school of engineering and technology IUPUI*, May 2014.
- [33] F. Incropera, *Fundamental of heat and mass transfer*. Wiley , New York.
- [34] W. Rohsenow, J. Hartnett, and Y. Cho, *Handbook of Heat Transfer*. McGraw-Hill Madison, 1998.
- [35] A. S. Kaka and H. Liu, *Heat Exchangers: Selection, Rating, and Thermal Design*. CRC. New York, 1998.
- [36] G. F. Nellis and S. A. Klein, *Heat Transfer*. Cambridge University Press, 2009, no. section 8.1.5.
- [37] O. Seppanen, W. Fisk, and M. Mendell, "Association of ventilation rates and co2 concentrations with health and other responses in commercial and institutional buildings," *Indoor Air* 9, pp. 226–252, 1999.
- [38] W. Source. Information on national weather [note: last accessed 18-feb-2016]. [Online]. Available: <http://weathersource.com>
- [39] EPA, "Indoor air quality tools for schools,iaq coordinator's guide, epa," *Washington, DC U.S. Environmental Protection Agency (EPA)*, no. 402-K-95-001, 1995.
- [40] D. Grimsrud, B. Bridges, and R. Schulte, "Continuous measurements of air quality parameters in schools," *Building Research and Information*, vol. 34, no. 5, pp. 447–458, 2006.
- [41] M. Mendell and G. Heath, "Do indoor pollutants and thermal conditions in schools influence student performance? a critical review of the literature, indoor air," *International Journal of Indoor Air Quality and Climate*, vol. 15, no. 1, pp. 27–52, 2005.
- [42] J. Daisey, W. Angell, and M. Apte, "Indoor air quality, ventilation and health symptoms in schools: an analysis of existing information, indoor air," *International Journal of Indoor Air Quality and Climate*, vol. 13, no. 1, pp. 53–64, 2003.
- [43] A. Synnefa, E. Polichronaki, and A. Delakou, "An experimental investigation of the indoor air quality in fifteen school buildings in athens, greece," *International Journal of Ventilation*, vol. 2, no. 3, pp. 185–202, 2004.