

12-2013

Developing Process Control Experiments for Undergraduate Chemical Engineering Laboratories

Chase M. Swaffar

University of Arkansas, Fayetteville

Follow this and additional works at: <http://scholarworks.uark.edu/etd>

 Part of the [Process Control and Systems Commons](#)

Recommended Citation

Swaffar, Chase M., "Developing Process Control Experiments for Undergraduate Chemical Engineering Laboratories" (2013). *Theses and Dissertations*. 1011.

<http://scholarworks.uark.edu/etd/1011>

This Thesis is brought to you for free and open access by ScholarWorks@UARK. It has been accepted for inclusion in Theses and Dissertations by an authorized administrator of ScholarWorks@UARK. For more information, please contact scholar@uark.edu, ccmiddle@uark.edu.

Developing Process Control Experiments for
Undergraduate Chemical Engineering Laboratories

Developing Process Control Experiments for Undergraduate Chemical Engineering Laboratories

A thesis submitted in partial fulfillment
of the requirements for the degree of
Master of Science in Chemical Engineering

by

Chase M. Swaffar
University of Arkansas
Bachelor of Science in Chemical Engineering, 2012

December 2013
University of Arkansas

This thesis is approved for recommendation to the Graduate Council.

Dr. Tom Spicer
Thesis Director

Dr. Ed Clausen
Committee Member

Dr. Roy McCann
Committee Member

ABSTRACT

It is the intent of this work to develop a process control apparatus and series of experiments that will help students visualize the PID (Proportional-Integral-Derivative) control of a process and enhance their understanding of the subject. The apparatus is a computer-controlled PID mixing system that responds quickly to set point changes and process disturbances which are directly observable. The system can easily be simulated with a transfer function model in Matlab's Simulink, so that the controller can be optimized for the desired system response. Four experiments can be conducted with this system including: exploration of system modeling and controller optimization in MatLab, set point tracking and disturbance rejection, the destabilizing effect of a time delay, and variable pairing in MIMO systems using the relative gain array (RGA). Several controller tuning methods are discussed, with both simulations and process performances reported and analyzed.

TABLE OF CONTENTS

I. INTRODUCTION	1
A. CALIBRATION	3
II. METHODS	5
A. MODELING	5
B. CONTROLLER SELECTION AND TUNING	8
III. DISCUSSION	12
A. SET POINT TRACKING AND DISTURBANCE REJECTION	12
B. DESTABILIZING EFFECTS OF TIME DELAY	15
C. MULTIVARIABLE CONTROL.....	17
IV. CONCLUSION.....	20
V. REFERENCES	21
APPENDIX A: EXPERIMENTAL PROCEDURE	22
APPENDIX B: LabView™ GUI.....	29
APPENDIX C: PARTS LIST	30
APPENDIX D: CALIBRATIONS	31

LIST OF TABLES

1) Material Balance Steady State Values	5
2) Theoretical Transfer Functions	6
3) PI Tuning-Parameters for Single Flask Control.....	9
4) PI Tuning-Parameters for Series Flask Control.....	10
5) Operating Conditions for Controlled/Manipulated Variable Pairing.....	18
6) Detailed Parts List.....	30

LIST OF FIGURES

1) The Apparatus	3
2) Spectrophotometer Linearity	4
3) Single-Flask Process Reaction Curve and FOPTD Model	7
4) Series-Flask Process Reaction Curve and FOPTD Model.....	7
5) Single-Flask Closed-Loop Model Responses to Input Disturbance and Step Set point Change for ITAE, Relay Auto-tuning, and Direct Synthesis Tuning Parameters	9
6) Series-Flask Closed-Loop Model Responses to Input Disturbance and Step Set point Change for ITAE, Relay Auto-tuning, and Direct Synthesis Tuning Parameters	11
7) Single-Flask Closed-Loop Process Responses to Step Set point Change for Relay Auto-tuning and Direct Synthesis Tuning Parameters	13
8) Single-Flask Closed-Loop Process Responses to Input Step Disturbance for Relay Auto-tuning and ITAE Tuning Parameters	13
9) Series-Flask Closed-Loop Process Responses to Step Set point Change for Relay Auto-tuning and Direct Synthesis Tuning Parameters	15
10) Series-Flask Closed-Loop Process Response to Step Input Disturbance for Relay Auto-tuning PID Parameters	15
11) Process Instability for 3 Flasks in Series Given a Step Set Point Change	17
12) ControlSoft Inc. Tuning Guidelines.....	17
13) Single-Flask Closed-Loop Process Responses to Step Set point Changes for Concentration and Flow Rate with Proper Variable Pairing	19
14) LabView™ VI GUI	29
15) High-Flow Mini Valve Calibration.....	31

16) Mini-Valve Calibration.....	31
17) Spectrophotometer Calibration for Methylene Blue at 640 nm.....	32
18) Flow Meter Calibration Data	33

I. INTRODUCTION

The typical chemical engineering undergraduate laboratory includes a broad assortment of experiments, but experiments that are focused on process control are often absent. It is the intent of this work to develop a process control apparatus and series of experiments that will help students visualize the PID (Proportional-Integral-Derivative) control of a process and enhance their understanding of the subject. The experimental equipment was developed to support four main experiments:

- 1) **System Modeling and Controller Optimization in MatLab:** Process reaction curves are generated so that approximate models can be derived to calculate initial controller settings using several methods. The simulated responses for the different tuning methods are then analyzed for the optimal method.
- 2) **Set Point Tracking and Disturbance Rejection:** Using the initial controller settings, set point tracking and disturbance rejection performance of the physical system are observed and quantified.
- 3) **The Destabilizing Effect of Time Delay:** The effect of added time delay on a tuned first-order system demonstrates how time delay can destabilize a system. The unstable (third-order) system is tuned using guidelines, and resulting controller settings are compared with settings from established techniques.
- 4) **Input/Output Variable Pairing using the 2 x 2 Relative Gain Array (RGA):** The effect of variable pairing and subsequent PID controller tuning is explored for a simple multi-input, multi-output (MIMO) system. Tuning and modeling for the stability of the MIMO system relies on the application of the Relative Gain Array (RGA) to pair control variables with their appropriate manipulated variables.

The apparatus is a computer-controlled PID mixing system that responds quickly to set point changes and process disturbances which are directly observable. The system can easily be simulated with a transfer function model in Matlab's Simulink, so that the controller can be optimized for the desired system response.

The experimental apparatus developed here (Figure 1) is based on a control experiment reported by Spencer (2009). Spencer's apparatus focused on acquiring impulse injection data and controller tuning via the Ziegler-Nichols method. The apparatus developed here was designed to meet the four objectives outlined above, and the process for the experiment mixes process water with a dye solution stream. To keep water quantities manageable and equipment costs reasonable, flow rates and valve/pump sizes are small.

A 20L polyethylene carboy (T-01) stores process water that is pumped via centrifugal pump (P-01) and controlled with an electronically actuated proportional valve (CV-01). A second flow of known dye concentration, stored in a separate carboy (T-02), is pumped via centrifugal pump (P-02) to a mixing tee with the water flow. Dye flow is also controlled via an electronically actuated proportional valve (CV-02). Depending on the experiment, the flow can be configured through either a single 290 mL Erlenmeyer flask (F-03) or a series of three 290 mL Erlenmeyer flasks (F-01, F-02, and F-03). Note that there is no provision for mixing within any of the flasks, and the flasks are piped so that the liquid volume in each flask is constant. Total flow through the process is measured via analog flow transmitter (FT-01). A spectrophotometer (CT-01) measures the dye concentration via transmission spectroscopy of the effluent water in a flow cuvette. It was found that city water had sufficient levels of impurities to warrant the use of a cartridge filter while filling the carboys to keep valves from fouling.

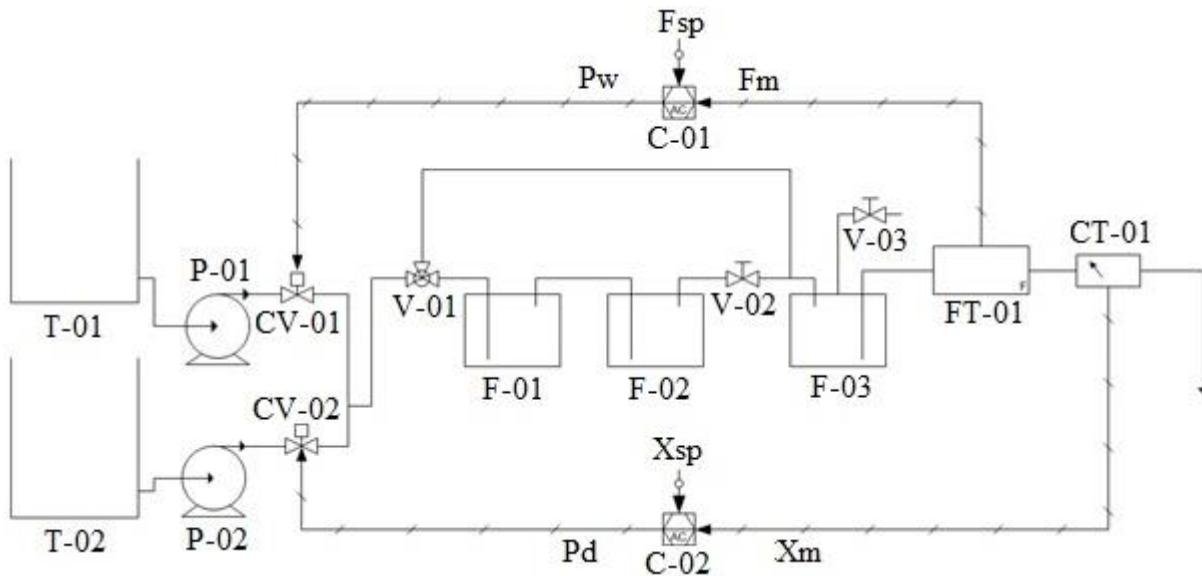

Figure 1. The experimental apparatus with controls configured to control total volumetric flow rate with process water flow rate and dye concentration with dye stream flow rate

The analog outputs of the spectrometer and flow transmitter are measured via the DAQ (Data Acquisition) module (NI USB- 6009) that is connected to a PC via USB interface. The analog data from the DAQ is read through National Instruments LabView™ VI (Virtual Instrument) software. Within LabView™, the real time initiation of PID control parameters, set-points, and process disturbances is easily performed. Dye concentration, total flow rate, and valve position are monitored and displayed in the LabView™ Graphic User Interface (GUI) (See Appendix B). Controller voltage output is transmitted through the DAQ module to current amplifier boards and ultimately to the dye and water controlling proportional valves.

A. CALIBRATION

The spectrophotometer must be first calibrated before any measurements are taken. The spectrophotometer should be allowed to warm up for at least 15 minutes before the calibration is performed. With only water flow through the cuvette, and the spectrophotometer set to 640 nm, the absorbance is set to zero. The spectrophotometer is now ready for use. The calibration curve for methylene-blue dye at 640 nm can be seen in Appendix D.

In addition to a digital display, the Unico 1100 Spectrophotometer's voltage output is linearly related to % transmittance, but unlike absorbance, % transmittance is not linearly correlated with concentration of dye. Fortunately, this non-linearity in measurement device output does not pose any problems within the set point range; where it is found to be essentially linear (Figure 2).

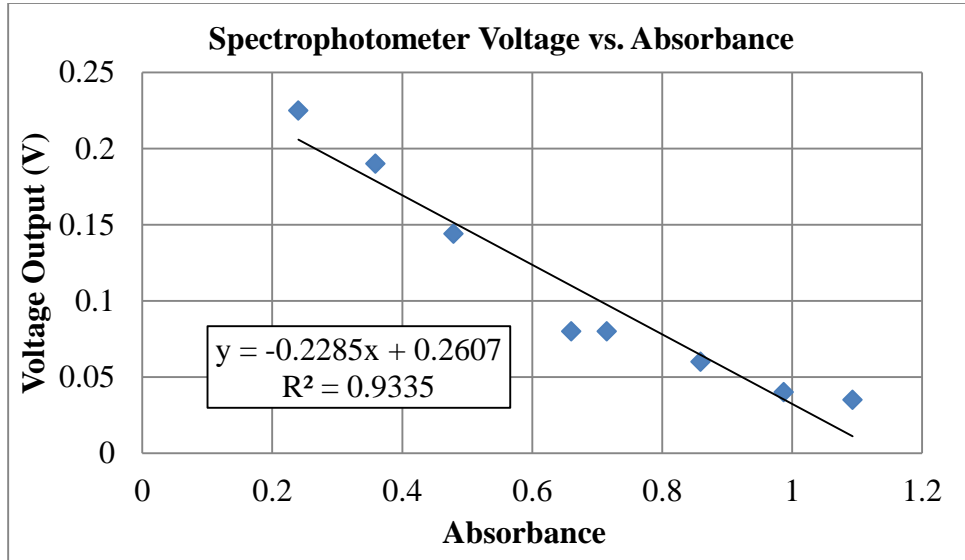

Figure 2. Spectrophotometer Linearity

The flow control valves and flow meter were also calibrated; the calibration curves can be seen in Appendix D. Recalibration of the control valves and flow transmitter should most likely be performed on an annual basis due to the possibility of fouling within the instruments.

II. METHODS

Control of the mixing process begins with modeling the system. Theoretical and empirical models are developed in the first section, and control settings based on the two modeling approaches are compared in the second section.

A. MODELING

The dynamics of the system are described mathematically from the material balance. With the material balance and knowledge of system specifications, theoretical models of the dynamic response can be generated prior to experimentation. The dye material balance for the single-flask system is given by Equation 1:

$$V_f \frac{dx}{dt} = F_D x_D - (F_D + F_W)x \quad (1)$$

Where V_f is the volume of the flask, x is the dye concentration in the flask, F_D is the flow rate of the dye containing stream, x_D is the concentration of the dye in the dye carboy, and F_W is the flow rate of water. Steady state values used in the derivation of the theoretical transfer functions are shown in Table 1. The volume of the flasks was obtained by weighing the amount of water required to fill the plugged flasks.

Table 1. Material Balance Steady State Values

Variable	Steady State Value
V_f	290 mL
x	2 mg/L
F_D	1.88 mL/s
x_D	20 mg/L
F_W	16.67 mL/s

Equation 1 can be applied to each flask. After linearizing, putting in deviation form, and taking the Laplace transform, the transfer functions shown in Table 2 are obtained. It should be noted that the theoretical transfer functions are only completely valid if the flasks are fully backmixed, which is not the case here.

Table 2. Theoretical Transfer Functions (time in seconds)

Flask	$\frac{x'(s)}{F_D'(s)}$	$\frac{x'(s)}{F_W'(s)}$
1	$\frac{0.97 \text{ (mg}\cdot\text{s/mL}\cdot\text{L)}}{15.6s+1}$	$\frac{-0.108 \text{ (mg}\cdot\text{s/mL}\cdot\text{L)}}{15.6s+1}$
2 and 3	$\frac{1}{15.6s+1}$	$\frac{1}{15.6s+1}$

Process reaction curves resulting from a step input can also be used to describe a system empirically. As discussed in many text books on the subject, process reaction curves are obtained by initiating a step change in the manipulated variable and plotting the output response (e.g., Seborg 2011). There are various graphical techniques that can be employed to fit a first or second-order model to the output response. Sundaresan and Krishnaswamy (1978) recommend a method which samples two times from the process reaction curve corresponding to the 35.3 and 85.3% response levels to calculate model parameters for a first order plus time delay (FOPTD) approximation. This method is typically preferred because it samples two data points from the process curve; whereas, other methods such as the tangent method presented by Seborg (2011) only uses a single point to estimate time constants. It is widely accepted that very few systems actually behave with first-order behavior due to process nonlinearities and unmeasured responses, even though this approximation is often useful.

Process reaction curves for both the single-flask and series-flask systems are shown in Figures 3 and 4, respectively. The empirical FOPTD model using process curve data and the theoretical FOPTD model responses are calculated and shown with the actual process responses in Figures 3 and 4. Both the theoretical and empirical response FOPTD models appropriately describe the behavior of the single-flask system and are suitable for simulating the process and

calculating tuning parameters. The accuracy of both modeling methods is expected since the single-flask system is an actual first-order process. However, the series-flask empirical FOPTD model deviates significantly from the actual process response due to its third-order dynamics. The series-flask empirical FOPTD model, although imperfect, is still useful for calculating initial controller settings. The third-order theoretical model for the series-flask system models the system extremely well as seen in Figure 4.

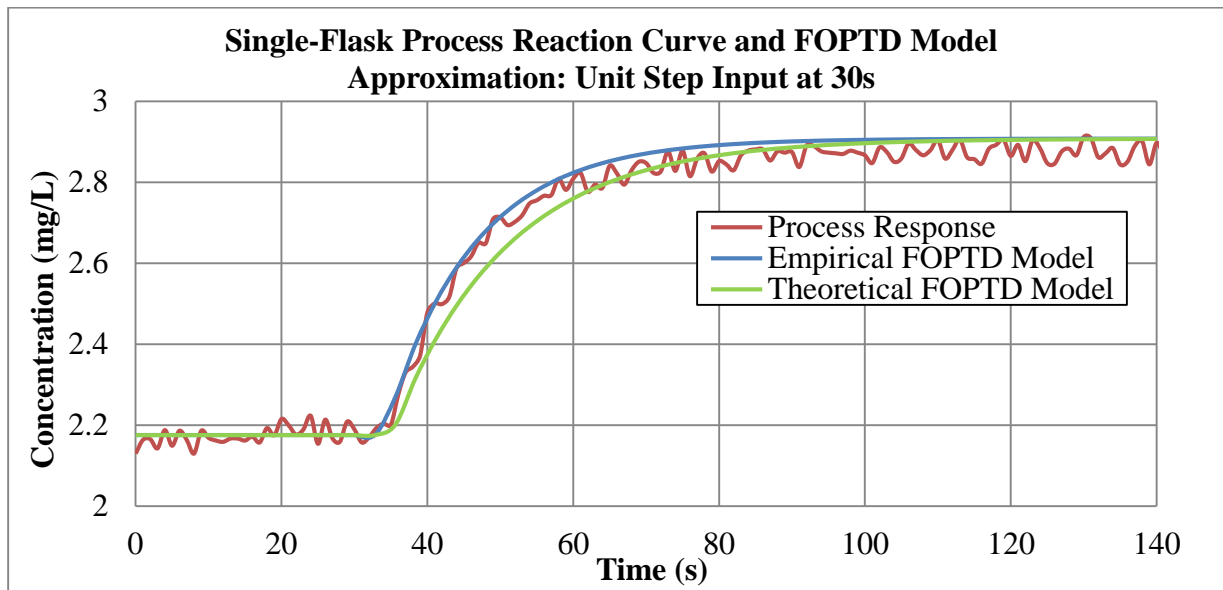

Figure 3. Single-Flask Process Response and FOPTD Models

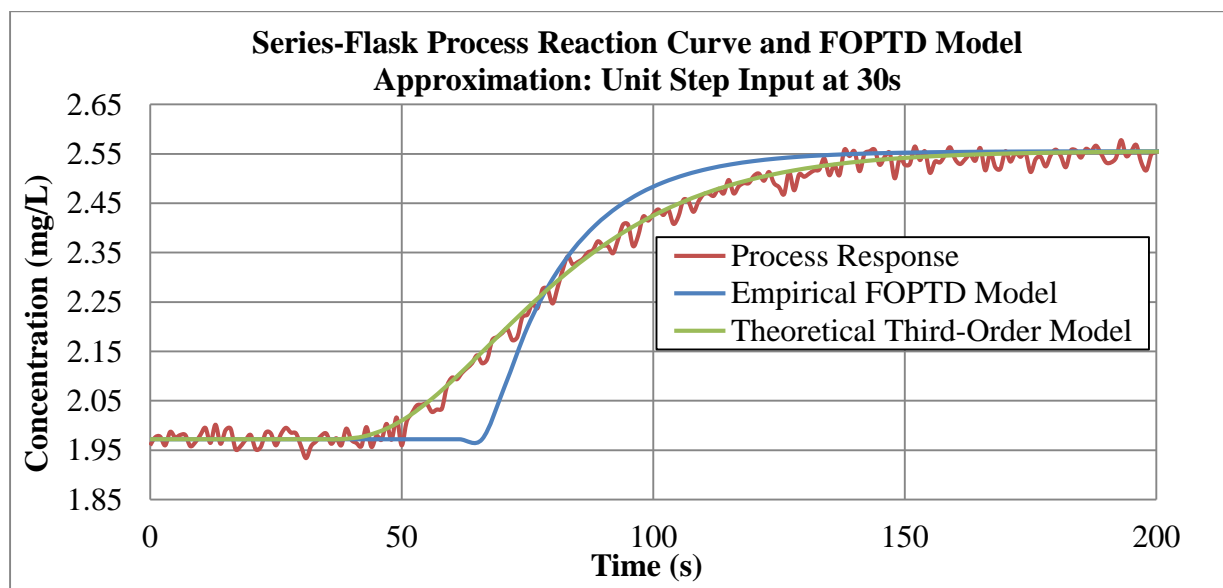

Figure 4. Series-Flask Process Response, FOPTD Model, and Third-Order Model

B. CONTROLLER SELECTION AND TUNING

With the empirical system models from the process reaction curves, the control loop is implemented in Simulink. Due to the fast response of the single-flask system, PI control is chosen to provide satisfactory performance, yet the series-flask system's slower response suggests that the addition of derivative action may improve performance over PI-only control.

The integral time-weighted absolute error (ITAE) calculation is a useful way to analyze controller performance because it provides a value for comparison that both penalizes persistent errors and overall control-response deviation; ITAE is calculated as follows:

$$\text{ITAE} = \int_0^{\infty} t|e(t)|dt \quad (2)$$

The ITAE performance index tuning method was developed to optimize the closed-loop response for a simple process by minimizing the ITAE (Smith and Corripio 1997); overshoot and response time are also values of interest when gauging controller performance and are included for comparison.

The relay-auto-tuning feature in Simulink tunes closed loop control systems based on desired performance criterion. Relay-auto-tuning uses step input changes of the manipulated variable and measures the controlled variable response to calculate controller settings based on the desired response time.

Although many approaches to choosing controller settings exist, the tuning methods used here include: ITAE performance index, relay-auto-tuning in Simulink, and direct synthesis (Chen and Seborg 2002).

The single-flask PI parameters for each method and their empirically modeled closed-loop responses to an input disturbance and step set point change can be seen in Table 3 and Figure 5, respectively. The modeled responses from Simulink suggest that all of the methods

provide satisfactory initial controller settings, but in this case, the ITAE performance index method is overly aggressive resulting in an unnecessarily large overshoot without considerably improving response time (or ITAE), and is thus not an appropriate method for this system. Conveniently, Simulink’s relay auto-tuning method directly calculates the predicted system response to input set point and disturbance steps so that the effect of controller settings are easily understood and analyzed.

Table 3. PI Tuning-Parameters for Single Flask Control

Tuning Method	Kc	Ti (min.)	Overshoot (%)	Response Time (s)	ITAE
ITAE	-25.57	0.269	11.40	35	21.04
Relay-Auto-tuning	-23.00	0.272	5.94	36	20.63
Direct Synthesis, $\tau_c=8$	-19.30	0.260	2.01	35	23.33

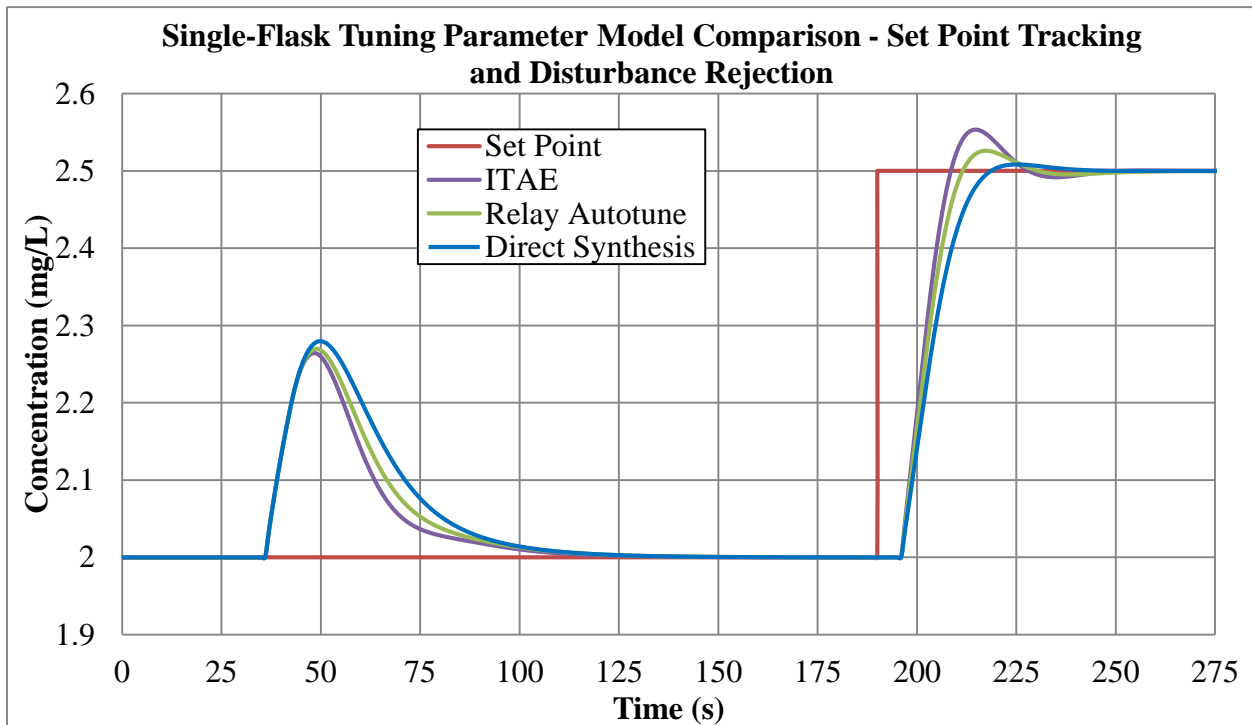

Figure 5. Single-Flask Closed-Loop Model Responses to Input Disturbance and Step Set point Change for ITAE, Relay-Auto-tuning, and Direct Synthesis Tuning Parameters

Utilizing the empirical FOPTD transfer function, the previously discussed tuning methods can now be effectively utilized on the third-order system. Due to the slower response of the series-flask system, the addition of derivative control is a consideration that may improve

controller performance. Interestingly, relay auto-tuning is the only method of the three discussed that calculates initial PID parameters whose simulation predicts an improved response time and ITAE value. The derived PI/PID controller parameters for the FOPTD approximation and their modeled closed-loop responses to a step set point change are shown in Table 4 and Figure 6, respectively. For the direct synthesis method, τ_c was chosen to minimize the overshoot and ITAE values. The PI controller parameters for the series-flask system are significantly more conservative than for the single-flask system. This “detuning” of the controller to more conservative parameters is to be expected with the addition of time delays from additional flasks. The modeled responses shown in Figure 6 indicate that relay auto-tuning is the best option for calculating initial PI and PID controller settings for the series-flask system due to the smallest overshoots, quickest response times, and smallest ITAE values.

Table 4. PI Tuning-Parameters for Series Flask Control

Tuning Method	Kc	Ti (min.)	Td (min.)	Overshoot (%)	Response Time (s)	ITAE
ITAE	-5.74	0.408	0	0	250	327.38
Relay-Auto-tuning - PI	-6.82	0.371	0	7.18	209	194.20
Direct Synthesis, $\tau_c = 20$	-5.35	0.254	0	10.1	248	264.81
Relay-Auto-tuning - PID	-30.93	0.694	0.151	7.56	138	48.38

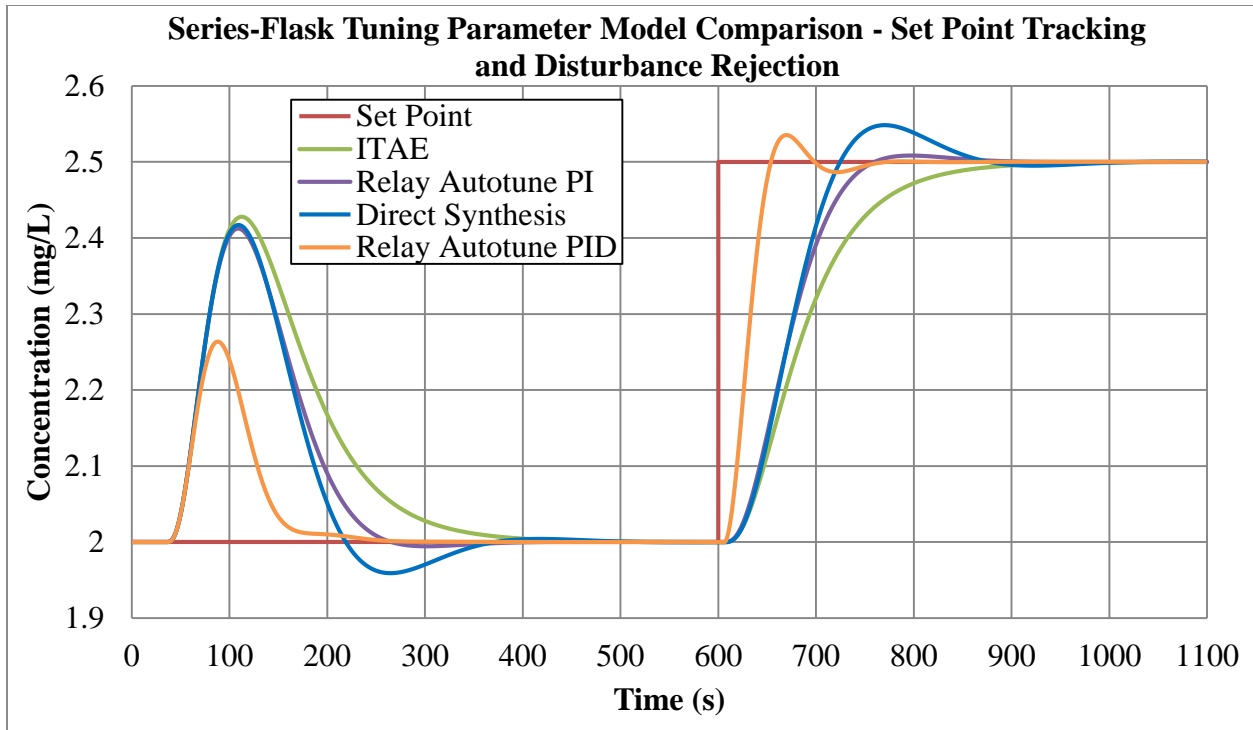

Figure 6. Series-Flask Closed-Loop Model Responses to Input Disturbance and Step Set point Change for ITAE, Relay-Auto-tuning, and Direct Synthesis Tuning Parameters

III. DISCUSSION

The mixing experiment was developed to emphasize three common aspects that are important to understanding process control. The first section explores set point tracking and disturbance rejection for the physical system, utilizing the controller settings previously derived. The second section exhibits the destabilizing effect of adding a time delay to measurement in the system. Simultaneous control of methylene blue concentration and total volumetric flow rate as well as methods to provide robust control of MIMO systems is discussed in the final section.

A. SET POINT TRACKING AND DISTURBANCE REJECTION

With the flow set to either a series or single-flask configuration via three-way valve, the water pump is started and metered to approximately 16.67 mL/s using the water-flow slider and reading the flow meter display on the LabView™ GUI developed for this experiment. With the water flow set, a step water-flow disturbance or concentration set point change can be initiated from the Single Loop System (SLS) GUI.

The desired set point and PID parameters can be varied at any point during the experiment by entering values into the appropriate dialog boxes in the SLS GUI. With the controller set to “Auto”, the SLS VI will sample the effluent flow concentration every second, implement the PID algorithm, and ultimately provide a control response. It is recommended that sampling times be between $1/10^{\text{th}}$ and $1/20^{\text{th}}$ of the dominant time constant for proper controller performance.

The modeled responses of the single-flask system suggested that the ITAE method provided the best disturbance rejection, yet the worst set point tracking of the three methods discussed as seen in Figure 5. Additionally, the simulations indicated that the relay auto-tuning method provided the best controller performance for both set point changes and disturbance rejection (Figure 5), and the physical process responses to set point change appropriately reflect

the performance predicted by the modeled system for both methods as shown in Figures 7 and 8.

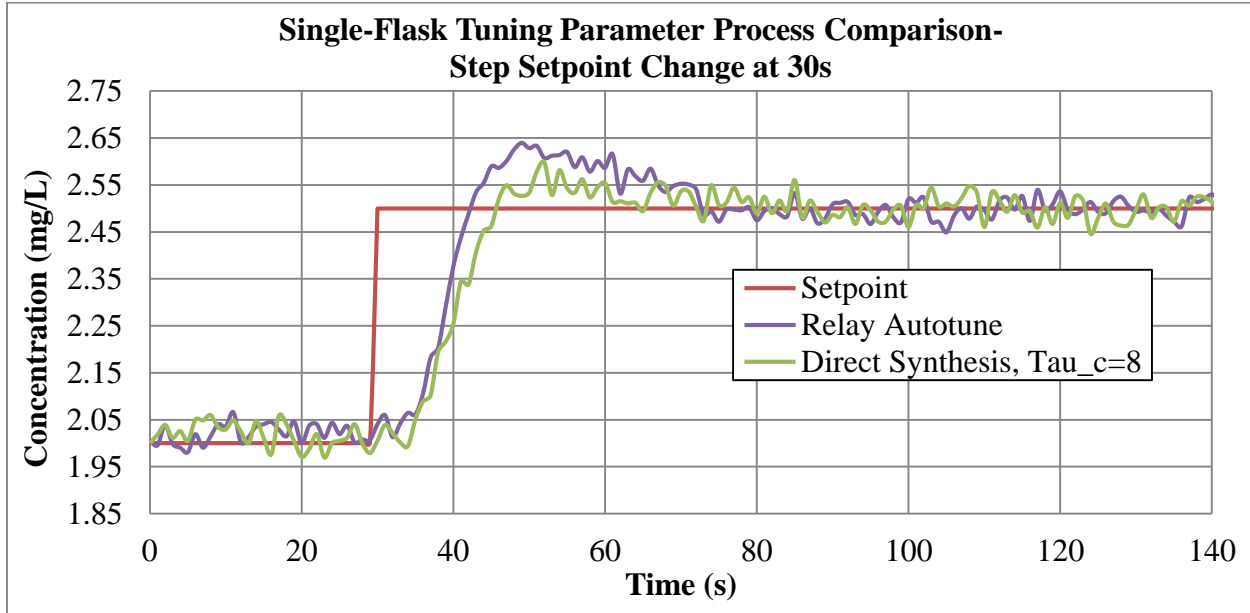

Figure 7. Single-Flask Closed-Loop Process Responses to Step Set point Change for Relay Auto-tuning and Direct Synthesis Tuning Parameters

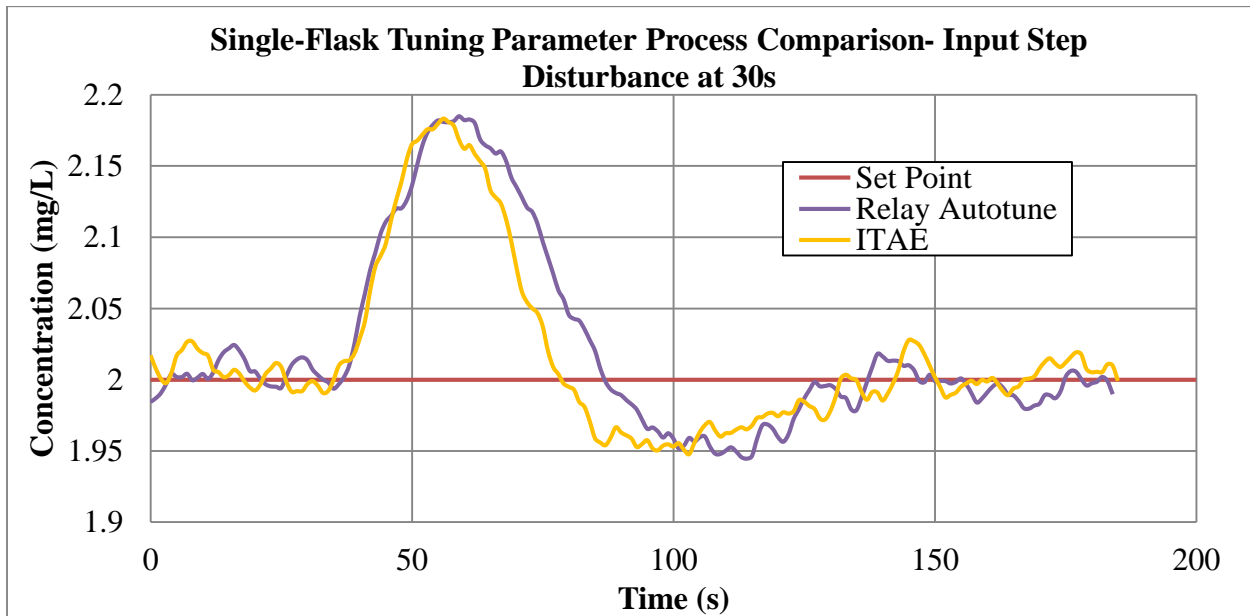

Figure 8. Single-Flask Closed-Loop Process Responses to Input Step Disturbance for Relay Auto-tuning and ITAE Tuning Parameters

For PI series-flask control, the relay auto-tuning method is simulated to have better set point response of the three methods discussed because both the ITAE performance criterion and direct synthesis methods are calculated using a faulty FOPTD approximation, while relay auto-

tuning considers the actual third-order dynamics of the system.

The simulations shown in Figure 6 indicate that relay auto-tuning PID is the best choice of the calculated tuning parameters for the series-flask system due to the having the quickest response time, without any added overshoot or oscillations, and the lowest ITAE value. The performance improvement using PID control compared to PI control is most substantial for disturbance rejection making PID control the only choice when handling disturbances.

Physical series-flask system responses to a set point change with both relay auto-tuning PI/PID and direct synthesis controller parameters are shown in Figure 9. Indeed, the relay auto-tuning PID control parameters result in the fastest response time, yet the overshoot is much larger than simulated. Depending on the type of process, controller settings resulting in a larger overshoot can be tolerated to obtain quicker response times. The criterion for controller performance varies amongst different applications, so choosing the “best” set of initial parameters is not always a definitive choice. Series-flask process response to an input disturbance of water flow for relay auto-tuning PID control parameters is also shown in Figure 10. Overall, the relay auto-tuning method is verified to provide the best set of initial controller settings for the series-flask control. If Simulink is not an available resource to compute controller settings, the direct synthesis method is a fair choice due to its low ITAE value and acceptable overshoot.

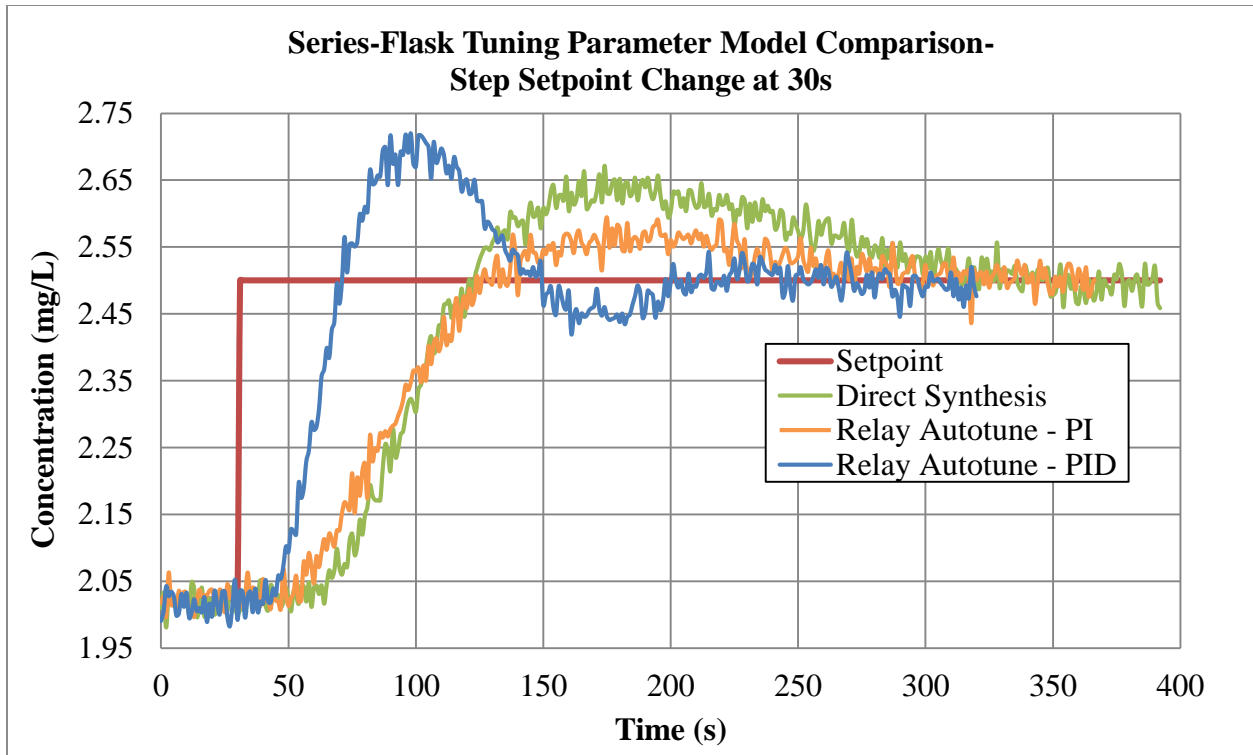

Figure 9. Series-Flask Closed-Loop Process Responses to Step Set point Change for Relay Auto-tuning and Direct Synthesis Tuning Parameters

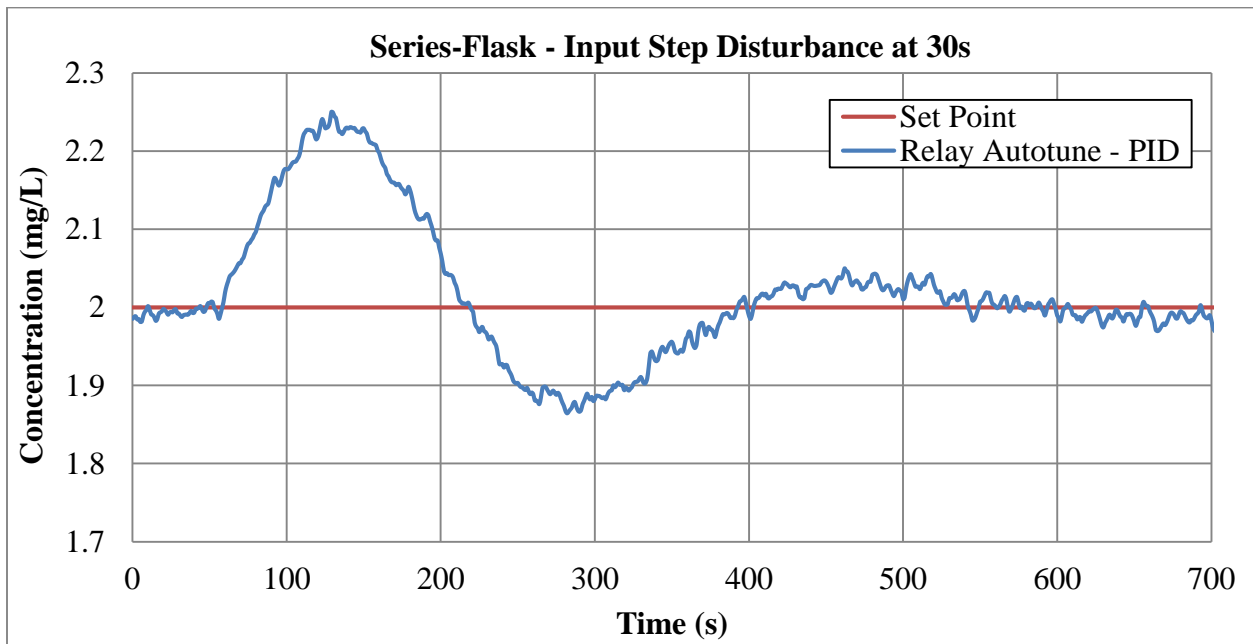

Figure 10. Series-Flask Closed-Loop Process Response to Step Input Disturbance for Relay Auto-tuning PID parameters

B. DESTABILIZING EFFECTS OF TIME DELAY

With the flow configuration set to a single-flask, the system is allowed to reach steady

state using the direct synthesis tuning parameters derived for the single-flask. With direct synthesis control parameters, the single-flask system has been shown to be stable under set point tracking (Figure 7). At steady state, the flow configuration is suddenly changed to all 3 flasks in series, but the control parameters are left unchanged. When subjected to a water flow disturbance, the process destabilizes quickly with an oscillatory behavior (Figure 11). This process instability is due to the added time delay from additional flasks on the measured concentration. To stabilize the series-flask system, control parameters are tuned using guidelines taken from the PID Loop Tuning Pocket Guide from ControlSoft Inc. (Figure 12). The guidelines from ControlSoft recommend reducing the proportional gain, K_c , by 50% and increasing the integral reset rate by 50% until sustained oscillations cease to propagate. Since the PID controller in LabView™ is in the parallel form, reducing the proportional gain by 50% also increases the integral reset rate by 50%. This reduction of proportional gain and integral reset rate was performed twice before the system was brought back to a stable operation (Figure 10), resulting in a change in K_c from -19.3 to -4.8. As expected, a K_c of -4.8 is similar to the proportional gains obtained using the previously discussed PI tuning methods for the series-flask system.

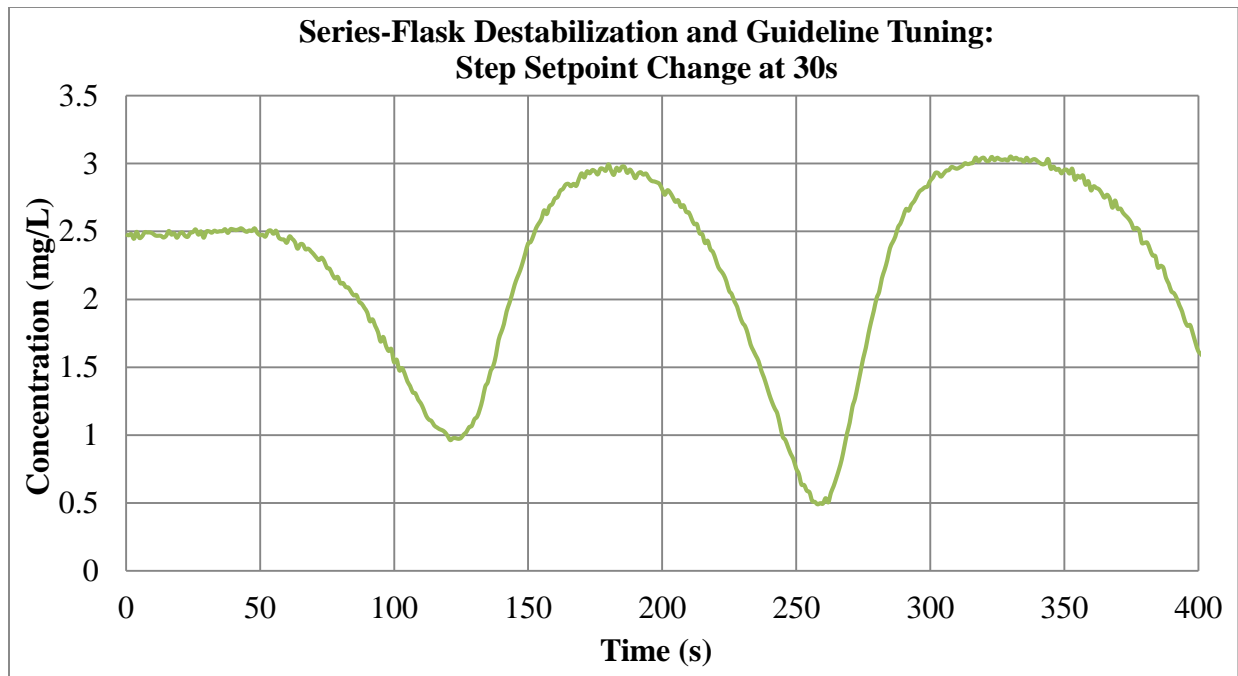

Figure 11. Process Instability for 3 Flasks in Series Given a Step Set Point Change

- Make a small change of setpoint (say 5%) or wait for a disturbance in the process. Then watch for process variable (PV) and control output (CO) responses.
- If no visible instantaneous change of CO upon the change of setpoint or no apparent overshoot (over damped), increase your proportional gain by 50%.
 - If the PV is unstable or has sustained oscillation, with overshoot greater than 25%, reduce Proportional Gain by 50% and reduce Integral Reset Rate by 50%.
 - If PV oscillation persists with tolerable overshoot, reduce Proportional Gain by 20% and reduce Integral Reset Rate by 50%.
 - If 3 or more consecutive peaks occur upon the change of setpoint, reduce Integral Reset Rate by 30% and increase Derivative Gain by 50%.
 - If PV stays fairly flat and below (or above) the setpoint for a long time, after change of setpoint or beginning of disturbance (long tail scenario), increase Integral Reset Rate by 100%.
- Repeat step 3 until the closed-loop response is satisfactory to you.

Figure 12. ControlSoft Inc. Tuning Guidelines

C. MULTI VARIABLE CONTROL

In many practical control problems, multiple variables are simultaneously measured and controlled. The proper pairing of manipulated and controlled variables is imperative to provide process stability. Control loop interactions can lead to destabilization of the process as well as make controller tuning much more difficult. In order to pair the manipulated variables (water and dye flow rates) with the proper controlled variables (overall flow rate and dye concentration) the Relative Gain Array (RGA) is used to quantify process interactions and predict the most

effective variable pairing(s) for stable closed-loop control.

Before a control scheme can be designed for a MIMO process, controlled/manipulated variable pairings must be determined. Using the previously derived process transfer functions, the RGA is constructed using established techniques (e.g., Bequette 2007). For the 2x2 case considered here, the relative gain, λ , between an input and output is the gain between this input/output (I/O) pair when all other loops are open compared with (divided by) the gain between the same I/O pair when all other loops are closed (Seborg 2011). For this system, λ is found to be $\frac{F_D}{F_D+F_W}$, with the form of the RGA expression shown in Equation 3.

$$\Lambda = \begin{matrix} & F_D & F_W \\ F & \begin{bmatrix} \lambda & 1-\lambda \\ 1-\lambda & \lambda \end{bmatrix} \\ x & \end{matrix} \quad (3)$$

For the base case considered here (Table 5 values), λ is 0.1, which recommends the pairing of set point dye concentration (x) with dye flow rate (F_D), and the total system throughput (F) with water flow rate (F_W). A λ of 0.1 also signifies that the loops do not interact severely and are both able to be controlled independently (Skogestad and Postlethwaite 2005). Note that if operating conditions are changed so that $\lambda > 0.5$, the recommended pairings would be reversed (so that outlet dye concentration is controlled with water flow rate and total flow rate is controlled with dye flow rate) as shown in Table 5.

Table 5. Operating Conditions for Controlled/Manipulated Variable Pairing

Variable	Dye Concentration/Dye Flow Rate Favored Pairing ($\lambda=0.1$)	Dye Concentration/Water Flow Rate Favored Pairing ($\lambda=0.9$)
F_W	16.67 mL/s	1.88 mL/s
x_D	20 mg/L	20 mg/L
F_D	1.88 mL/s	16.67
x	2 mg/L	18 mg/L
F	18.55 mL/s	18.55 mL/s

With appropriate variable pairings concluded, one of the previous tuning methods can be used to calculate initial controller settings for each of the individual loops alone without interactions. Using initial controller settings, the flow configuration is set to either a single flask

or all 3 flasks in series and the system is allowed to reach steady state near the desired operating ranges in manual mode. Both PID controllers are then switched to auto and the system is allowed to reach steady state at the defined concentration and flow rate set points in auto mode. Physical single-flask system responses to concentration and flow rate set point change with the proper variable pairing are shown in Figure 13. The direct synthesis controllers parameters calculated for each loop without interactions were used and result in adequate controller performance. This is expected due to the low extent of loop interactions.

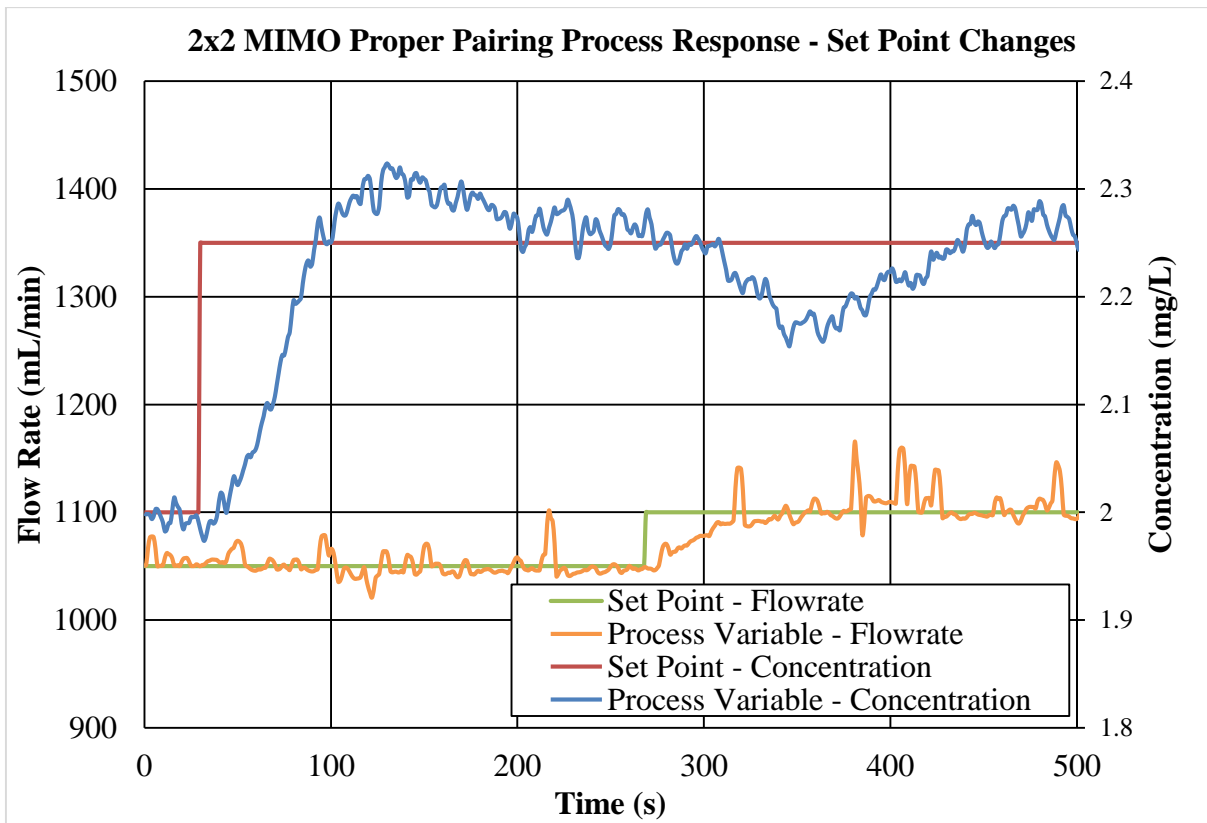

Figure 13. Single-Flask Closed-Loop Process Responses to Step Set point Changes for Concentration and Flow Rate with Proper Variable Pairing

If the loops have heavy interaction, the tuning parameters calculated for the independent loops may require modification for desired controller performances. The “detuning method” is used which detunes the control parameters by decreasing gains and increasing integral times; effectively making the controllers more conservative (Luyben 1986).

IV. CONCLUSION

Process control is an integral part of understanding how chemical process industries maintain quality control and optimal operation. With the increase of computing power at a lower cost, high-performance measurement and control systems have become an essential part of chemical plants (Seborg 2011).

With this process control apparatus, many important aspects of process control are explored and realized. Multiple experiments can be performed that emphasize the modeling of a system, tuning a controller with simulations, the destabilizing effects of time delay, the analysis of set-point tracking and disturbance rejection, and proper variable pairing via the RGA in a MIMO system.

REFERENCES

- Bequette, B. Wayne. "Process Control: Modeling, Design, and Simulation." Prentice Hall, New Jersey, 2007.
- Chen, D., and D.E. Seborg. "PI/PID Controller Design Based on Direct Synthesis and Disturbance Rejection." *Ind. Eng. Chem. Res.*, 41, 4807 (2002).
- Luyben, W. L., "Simple Method for Tuning SISO Controllers in Multi-Variable Systems." *IEC Process Des. Dev.*, 25, 654 (1986).
- Seborg, Dale E., Thomas F. Edgar, Duncan A. Mellichamp, and Francis J. Doyle, III. "Process Dynamics and Control." 3rd ed., Wiley, New York, 2011.
- Skogestad, S., and I. Postlethwaite. "Multivariable Feedback Control." 2nd ed., Wiley, New York, 2005.
- Smith, C. A., and A. B. Corripio. "Principles and Practice of Automatic Control." 2nd ed., John Wiley, New York, 1997.
- Spencer, Jordan L. "A Process Dynamics and Control Experiment for the Undergraduate Laboratory." *Chemical Engineering Education* 43.1 (2009): 23-28.
- Sundaresan, K. R., and R. R. Krishnaswamy. "Estimation of Time Delay, Time Constant Parameters in Time, Frequency, and Laplace Domains." *Can. J. Chemical Engineering.*, 56, 257 (1978).

APPENDIX A. EXPERIMENTAL PROCEDURE

RALPH E. MARTIN DEPARTMENT OF CHEMICAL ENGINEERING

UNIVERSITY OF ARKANSAS
FAYETTEVILLE, AR

CHEG 4332
CHEMICAL ENGINEERING LABORATORY III

PID CONTROL OF A FLOW SYSTEM

OBJECTIVE

Proper control loop tuning in chemical plants is imperative in maintaining quality and throughput. Tuning parameter estimation and control loop simulation is performed to provide robust initial settings before employing them in the physical plant. This experiment is designed to provide students with the experience of modeling a physical system, tuning a PID controller, and operating a feedback control system.

THEORETICAL DISCUSSION

The purpose of this experiment is to give students experience in modeling and operating a PID (Proportional-Integral-Derivative) control system. The flow control system used in this experiment is shown in Figure 1 below.

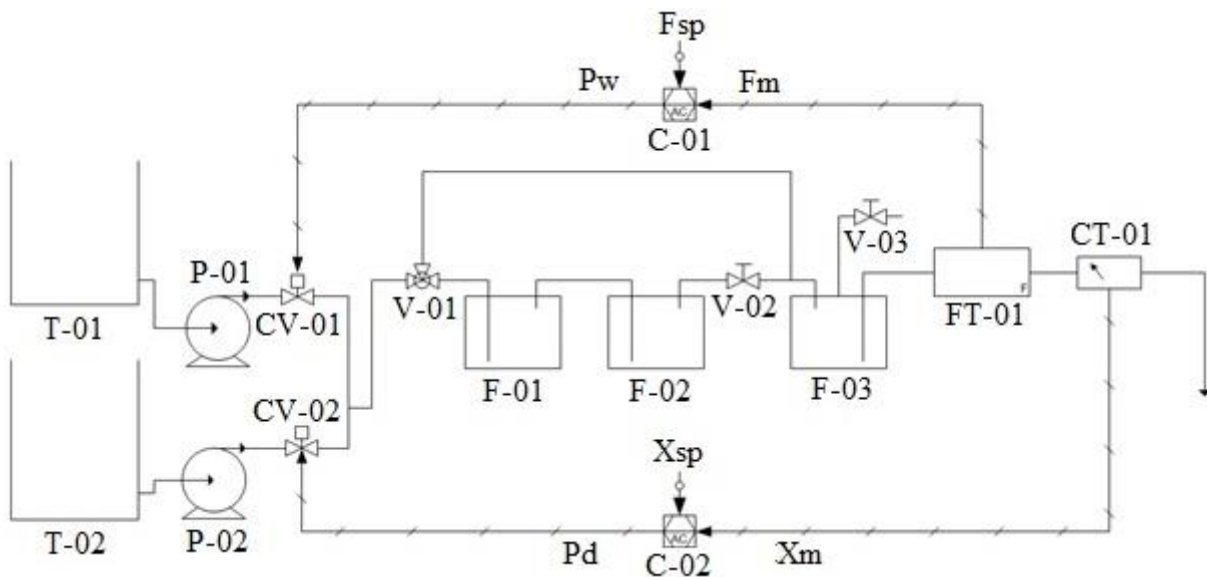

Figure 1. Experimental Apparatus

A 20L polyethylene carboy (T-01) stores process water that is pumped via centrifugal pump (P-01) and controlled with an electronically actuated proportional valve (CV-01). A second flow of known dye concentration, stored in a separate carboy (T-02), is pumped via centrifugal pump (P-02) to a mixing tee with the water flow. Dye flow is also controlled via an electronically actuated proportional valve (CV-02). Depending on the experiment, the flow can be configured through either a single 290 mL Erlenmeyer flask (F-03) or a series of three 290 mL Erlenmeyer flasks (F-01, F-02, and F-03). Note that there is no provision for mixing within any of the flasks, and the flasks are piped so that the liquid volume in each flask is constant. Total flow through the process is measured via analog flow transmitter (FT-01). A spectrophotometer (CT-01) measures the dye concentration via transmission spectroscopy of the effluent water in a flow cuvette.

The analog outputs of the spectrophotometer and flow transmitter are measured via the DAQ (Data Acquisition) module that is connected to a PC via USB interface. The analog data from the DAQ is read through National Instruments LabView™ VI (Virtual Instrument) software. Within LabView™, the real time initiation of PID control parameters, set-points, and process disturbances is easily performed. Dye concentration, total flow rate, and valve position are monitored and displayed in the LabView™ Graphic User Interface (GUI). Controller voltage output is transmitted through the DAQ module to current amplifier boards and ultimately to the dye and water controlling proportional valves.

Before entering the lab, students will be required to model the feedback control system in MatLab's Simulink. A transfer function characterizing the dynamics of the flow system is required in order to calculate initial controller settings and model controller behavior. Process reaction curves are often generated to provide insight on the dynamic behavior (and subsequent transfer function) of an open-loop control system. Transfer function models resulting from reaction curves typically provide a more accurate representation when compared to theoretical models because they account for all dynamic behavior within the physical system. The single-flask and series-flask process reaction curves for the flow system, given a unit step dye valve voltage change, is shown in Figures 2 and 3, respectively.

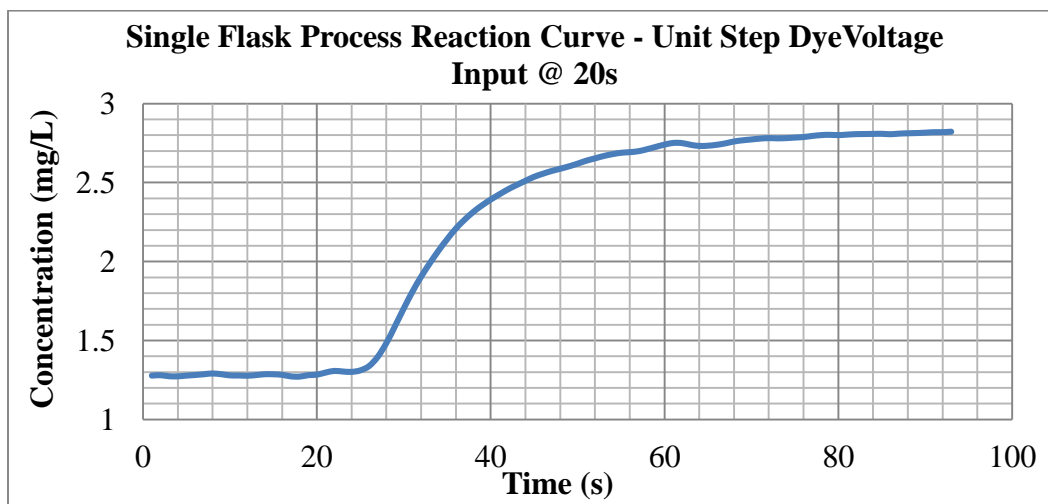

Figure 2. Single-Flask Process Reaction Curve

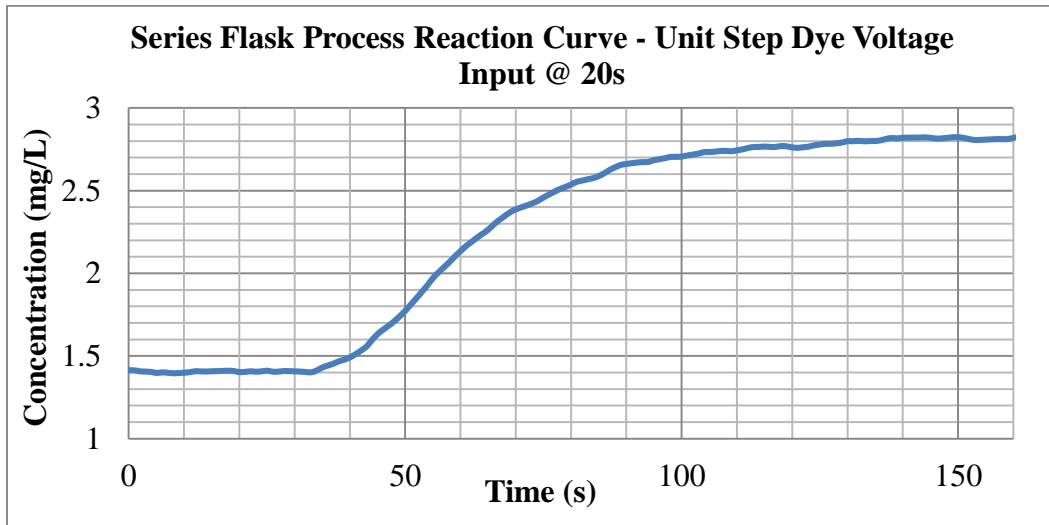

Figure 3. Series-Flask Process Reaction Curve

From the process reaction curve, the overall FOPTD (First Order Plus Time Delay) transfer function seen in Equation 1 can be approximated using the method proposed by Sundaresan and Krishnaswamy (1978) and shown below in Equations 3 and 4. The times t_1 and t_2 are when the system has reached 35.3 and 85.3% of the ultimate response, respectively.

$$G(s) = \frac{Ke^{-\theta s}}{\tau s + 1} \quad (1)$$

$$K = \frac{\Delta \text{Concentration } \left(\frac{\text{mg}}{\text{L}}\right)}{\Delta \text{Valve Voltage (V)}} \quad (2)$$

$$\theta = 1.3t_1 - 0.29t_2 \quad (3)$$

$$\tau = 0.67(t_2 - t_1) \quad (4)$$

The disturbance transfer function can be assumed to have the same θ and τ as the process transfer function, but with a gain, K , of -0.26 mg/L/V .

The effect of two additional flasks in series can be modeled by the addition of two first order transfer functions to the FOPTD transfer function for a single flask. However, in order to utilize the Direct Synthesis tuning equations for the series-flask configuration, the two additional first order transfer functions must be approximated as time delays. The time delay simplification for each additional flask is given by Equation 5 below:

$$e^{-\theta s} = \frac{1}{\theta s + 1} \quad (5)$$

Students should compare the FOPTD approximation derived from the series-flask process reaction curve to the simplified time delay FOPTD approximation and calculate initial controller settings using the best approximation.

Knowledge of the gain on the concentration transmitter (spectrophotometer) is required as well to model the feedback control system. The spectrophotometer gain should be obtained using the calibration curve in Figure 4. After obtaining the FOPTD transfer function approximation for the system, the relay autotuning feature of Simulink and the Direct Synthesis method are used to estimate initial PI tuning parameters. The PI tuning parameters using the Direct Synthesis method are given by:

$$K_c = \frac{1}{K} \frac{\tau}{\theta + \tau_c}, \quad \tau_I = \tau \quad (6)$$

Selection of τ_c should be chosen so that: $\tau > \tau_c > 0$. It will be left up to the students on the final selection of τ_c that results in optimal simulated controller performance. It should be noted that the PID controller in LabView™ is in ideal form and τ_I is in units of minutes.

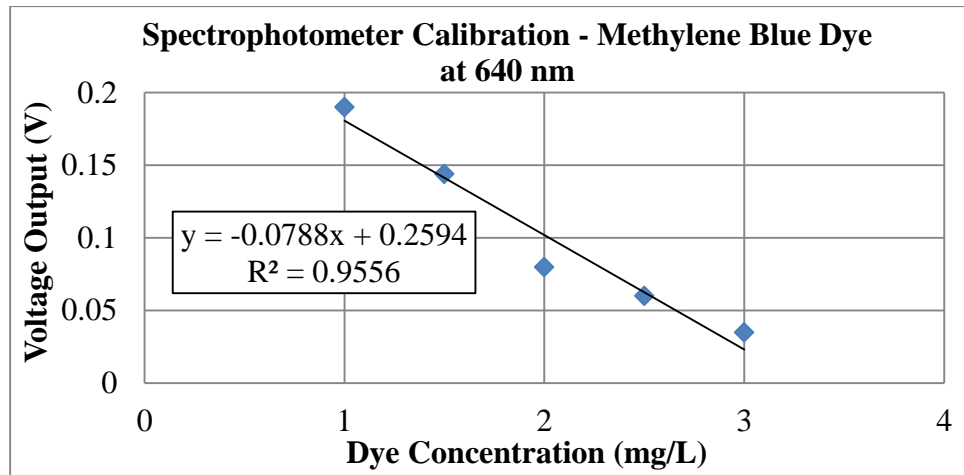

Figure 4. Spectrophotometer Calibration Curve

With the initial tuning parameters calculated and the closed-loop system modeled, the students are now ready to perform control experiments with the physical system.

MINIMUM REPORT REQUIREMENTS

Using the process reaction curves generated, determine the FOPTD transfer functions using the t_1 - t_2 method discussed above. Model the system in Simulink with the derived FOPTD transfer functions in order to obtain initial controller settings using Direct Synthesis and Relay Autotuning methods. Compare the tuning methods by simulating the process response to set point changes as well as disturbance rejection and propose a “best” set of controller settings for both the single-flask and series-flask configurations.

With the initial controller settings proposed, perform set point change and disturbance rejection experiments to obtain experimental data. After observing the systems initial performance, adjust controller parameters per the ControlSoft tuning guidelines seen in Figure 5 and perform the same set point change and disturbance rejection experiments. Prepare a memo report transmitting your data, commenting on the process responses and their deviation from

simulated responses, any issues encountered, what improvements could be made, etc. Report initial and final controller parameters and explain why the changes were made and their effect on controller performance.

PROCEDURE

Preparation

1. Plug in and turn on the Unico 1100 spectrophotometer and allow it to warm up for at least 15 minutes before any measurements are taken.
2. Set the spectrophotometer wavelength to 640 nm via the dial and the measurement type to absorbance mode.
3. Loosen the lids on both the dye and water carboys to allow for ventilation.
4. Set the flow configuration through either a single flask or through all 3 flasks in series using the 3-way valve.
5. If flasks are not already full of liquid, loosen the air-vent valve on the last flask to allow for any air bubbles to escape.
6. Connect the DAQ module to the computer via the white USB cable.
7. Turn on the computer and Startup the NI LabView™ program and open “PC-VI.vi”.
8. Make sure the control system is set to manual, and set the water flow voltage to 4.0 V.
9. Start the VI by pressing run, and then switch the water pump on.
10. Vent any air that accumulates in the final flask until it is completely full of liquid.
11. Allow only water to flow through the system and then press “Zero” on the spectrophotometer to set the absorbance to 0.00.
12. Stop the VI and switch the water pump off. The system is now ready to run an experiment.

Process Reaction Curve

1. Switch the controller to manual mode on the LabView™ VI.
2. Start the VI by pressing run, and then switch the water pump on.
3. Meter the water flow to ~1000 mL/min. by adjusting the water-valve voltage slider and observing the flow rate reading from the VI. (~4.0V)
4. Now switch the dye pump on and adjust the dye-valve voltage slider in 1 volt increments every 30 seconds until the desired concentration is achieved.
5. Once at steady-state, initiate a unit step voltage change on the dye-valve voltage slider and allow the system to reach the new steady-state.
6. Stop the VI by pressing “stop” and switch both of the pumps off.
7. Right click on the concentration waveform-chart from the VI and click export>export to excel in order to generate the process reaction curve.

Set Point Tracking and Disturbance Response

1. Input the initial controller settings derived from the system model and simulations into the LabView™ VI.

2. Input the desired set point value in mg/L (1-3 mg/L).
3. Switch the controller to manual mode.
4. Start the VI by pressing run, and then switch the water pump on.
5. Meter the water flow to ~1000 mL/min. by adjusting the water-valve voltage slider and observing the flow rate reading from the VI. (~4.0V)
6. Now switch the dye pump on and adjust the dye-valve voltage slider in 1 volt increments every 30 seconds until the concentration reading on the VI is near the desired set point.
7. Now switch the controller to auto.
8. Observe as the system reaches steady-state in closed-loop mode.
9. Once at steady-state, initiate a concentration set point change (+/- 0.5 mg/L) or input disturbance of water flow (+/- 25%) from the VI.
8. Monitor the response of the system as it reaches steady-state again.
9. Stop the VI by pressing “stop” and switch both of the pumps off.
10. Right click on any graph from the VI and click export>export to excel in order to analyze the data.

Make a small change of setpoint (say 5%) or wait for a disturbance in the process. Then watch for process variable (PV) and control output (CO) responses.

- If no visible instantaneous change of CO upon the change of setpoint or no apparent overshoot (over damped), increase your proportional gain by 50%.
- If the PV is unstable or has sustained oscillation, with overshoot greater than 25%, reduce Proportional Gain by 50% and reduce Integral Reset Rate by 50%.
- If PV oscillation persists with tolerable overshoot, reduce Proportional Gain by 20% and reduce Integral Reset Rate by 50%.
- If 3 or more consecutive peaks occur upon the change of setpoint, reduce Integral Reset Rate by 30% and increase Derivative Gain by 50%.
- If PV stays fairly flat and below (or above) the setpoint for a long time, after change of setpoint or beginning of disturbance (long tail scenario), increase Integral Reset Rate by 100%.

Repeat step 3 until the closed-loop response is satisfactory to you.

Figure 5. ControlSoft Inc. Tuning Guidelines

Destabilizing Effect of Time Delay

1. Input the initial controller settings derived from the single-flask system model and simulations into the LabView™ VI.
2. Input the desired set point value in mg/L.
3. Set the flow configuration to series-flask.
4. Switch the controller to manual mode.
5. Start the VI by pressing run, and then switch the water pump on.
6. Meter the water flow to ~1000 mL/min. by adjusting the water-valve voltage slider and observing the flow rate reading from the VI. (~4.2V)
7. Now switch the dye pump on and adjust the dye-valve voltage slider in 1 volt increments every 30 seconds until the concentration reading on the VI is near the desired set point.
8. With set point liquid in all three flasks, switch the controller to auto mode.

9. Initiate a concentration set point change (± 0.5 mg/L) or input disturbance of water flow ($\pm 25\%$) from the VI.
10. Monitor the response of the system as it oscillates out of stable control.
11. Stop the VI by pressing “stop” and switch both of the pumps off.
10. Tune the controller based on the ControlSoft tuning guidelines in Figure 5 and perform the same set point change or water flow disturbance until the system becomes robust.
11. Right click on any graph from the VI and click export>export to excel in order to analyze the data.

APPENDIX B: LabView™ VI GRAPHIC USER INTERFACE

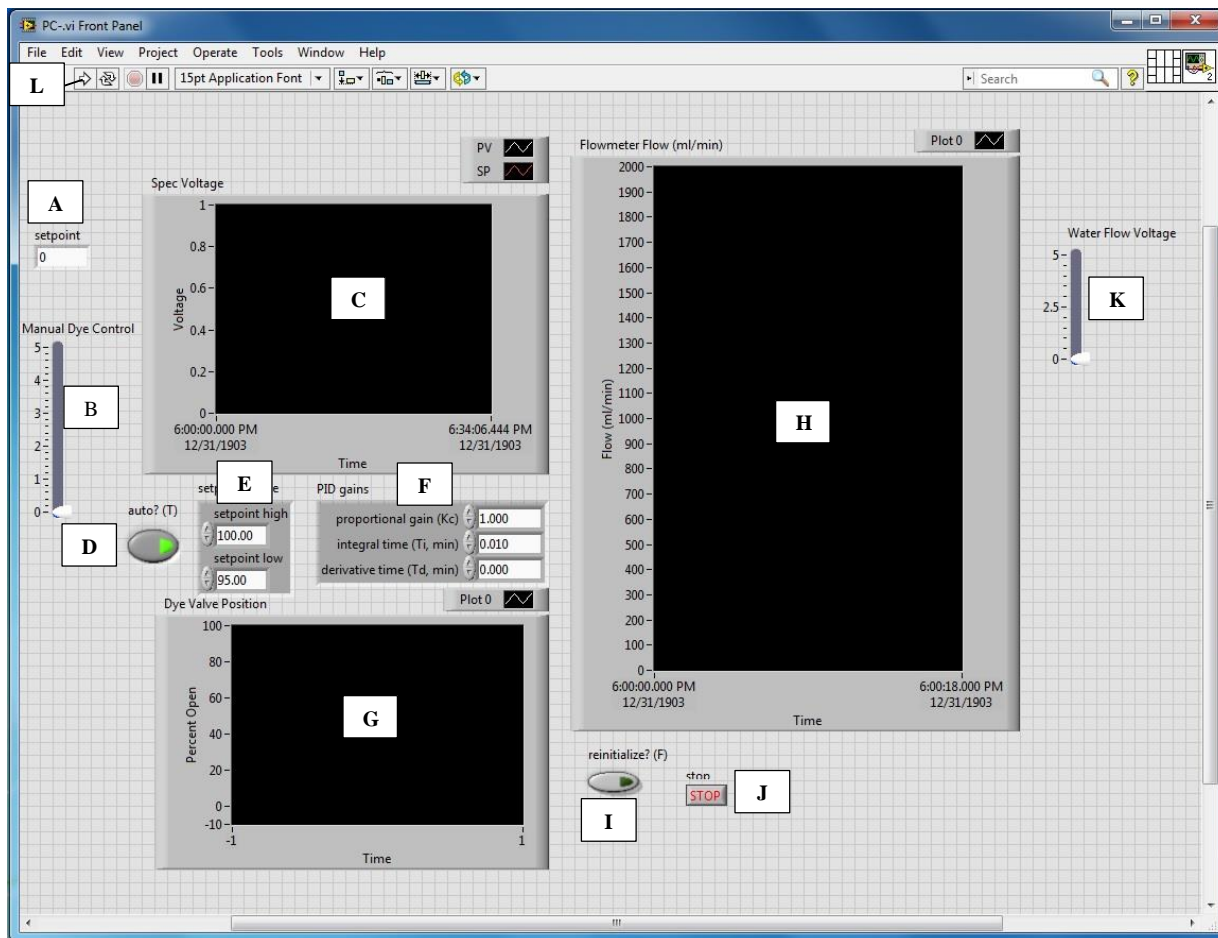

Figure 14. LabView™ VI GUI

- A. Desired Set point Input Dialog Box
- B. Manual Dye Valve Voltage Slider
- C. Process and Set point Variable Waveform Graph
- D. PI “Auto” Button to Toggle Closed Loop and Manual Control
- E. Set point Range Input Dialog Boxes (Minimum and Maximum Setpoint Requirements)
- F. PID Controller Parameter Input Dialog Boxes
- G. Dye Valve Position Waveform Graph (% Open)
- H. System Flow Rate Waveform Graph
- I. Reinitialization Button to Reset Integral and Derivative Error Values
- J. Stop Button
- K. Manual Water Valve Voltage Slider
- L. Start Button

APPENDIX C: PARTS LIST

Table 6. Detailed Parts List

Equipment	Description	Price
Tanks and Flasks		
T-01, T-02	20 liter Nalgene Polyethylene Carboy with Spigot Contains process water	\$177.00
F-01	290 mL Pyrex Erlenmeyer Flask	N/A
F-02	290 mL Pyrex Erlenmeyer Flask	N/A
F-03	290 mL Pyrex Erlenmeyer Flask	N/A
Manual Valves		
V-01	Swagelok Brass Three-Way Valve Model #: B-43XF4	\$95.99
V-02	Parker Compact 316 SS Ball Valve with Yor-Lok Fittings	\$88.76
V-03	Parker Compact 316 SS Ball Valve with Yor-Lok Fittings	\$88.76
Pumps		
P-01, P-02	Shurflo AC Magnetic Drive Centrifugal Pump Model #: 8020-503-250 45 psi internal bypass 1.4 gpm open flow	\$144.67
Transmitters		
FT-01	Flow Technologies Omniflo Turbine Flow Meter with Linear Link Model #: FTO-4NINWBLHC-1	\$1999.47
CT-01	Unico 1100 Spectrophotometer 110 V AC 20nm Bandpass	\$729.99
Control Elements		
CV-01	Kelly Pneumatics High Flow Mini Proportional Valve and Driver Board Model #: KPIH-TPW-20-90-50 50 psig working pressure 0-2900 mL/min. flow range 0-5 V analog input signal	\$223.60
CV-02	Kelly Pneumatics Mini Proportional Valve and Driver Board Model #: KPI-TPW-20-60-50 50 psig working pressure 0-450 mL/min. flow range 0-5 V analog input signal	\$166.60
C-01	Personal Computer (PC) with NI LabView™ Software and USB Connection	N/A

APPENDIX D: CALIBRATIONS

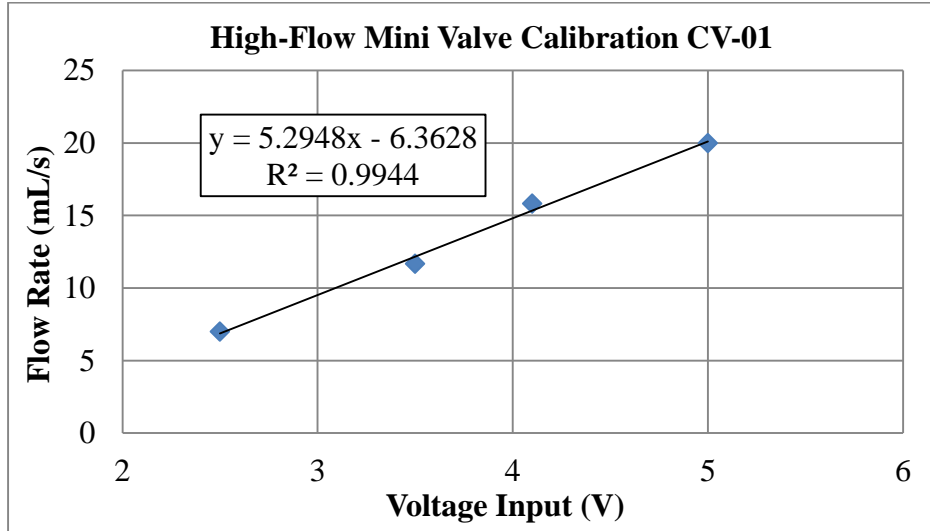

Figure. 15 High-Flow Mini Valve Calibration

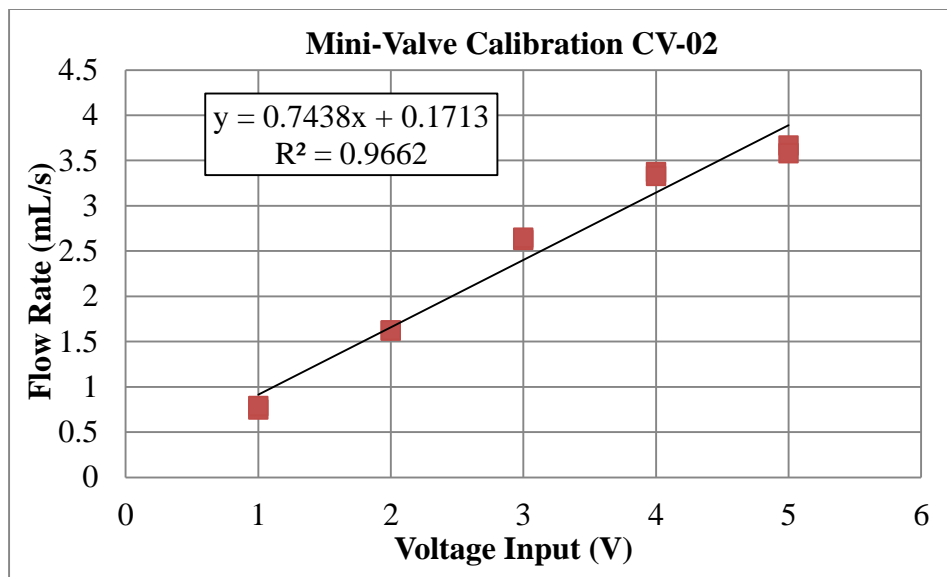

Figure. 16 Mini-Valve Calibration

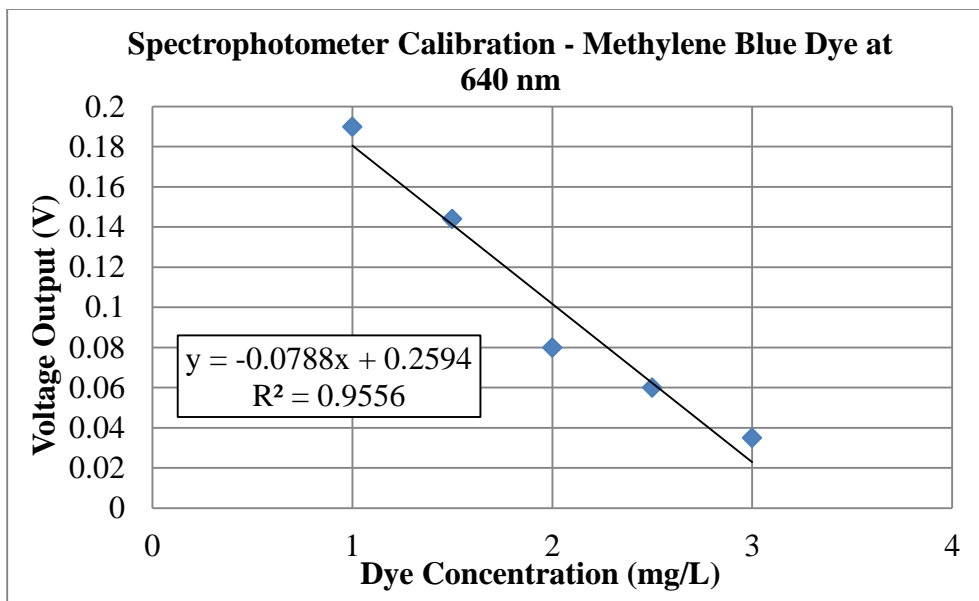

Figure 17. Spectrophotometer Calibration for Methylene Blue at 640 nm



8930 S. Beck Ave. Suite 107, Tempe, AZ 85284

Phone: (480) 240-3400

Fax: (480) 240-3401

Email: ftimarket@ftimeters.com

Website: www.ftimeters.com

DOWNLOAD DATASHEET - Linear Link

CUSTOMER INFORMATION

Customer Name: UNIVERSITY OF ARKANSAS
Job Number: 16524-02
P.O. Number: CC Chase Swaffer

ELECTRONICS INFORMATION

Electronic Model Number: LA-5-C-V2-9
Electronic Serial Number: 130211E20173
Electronic Tag Number: N/A
Electronic Calibration Date: 2/11/2013
Calibration Equipment Inventory: 51546 51746 51580 51261 51710
Technician: S. GARCIA

Approval: _____

FREQUENCY INPUT: Input Averaging: 6
FREQUENCY OUTPUT: Type: Volume Flow

Scaling: 0 Hz = 0, 2000 Hz = 2.000 lt/min

Linearized K-Factor: 60000.000 P/Liters

ANALOG OUTPUT: Type: Volume Flow

Scaling: 0 V = 0, 5 V = 2.000 lt/min

DATA UNITS

Volume: Liters

Mass: Pounds

Time: Minute

FLOW METER INFORMATION

Meter Model Number: FTO-4NINWBLHC-1
Meter Serial Number: 130201M19979
Meter Tag Number: N/A

COMPOSITE CURVE INFORMATION

Freq [Hz]	K-Factor [P/Liters]	Density [lb/lt]	Volume Rate [lt/min]	Mass Rate [lb/min]	Freq Out [Hz]	Analog Out [Volts]
503.959	14947.362	1.000	2.0229	2.0229	NaN	NaN
431.599	14940.282	1.000	1.7333	1.7333	1733.29	4.333
375.474	15165.517	1.000	1.4855	1.4855	1485.51	3.714
316.645	15133.146	1.000	1.2554	1.2554	1255.44	3.139
270.342	15009.211	1.000	1.0807	1.0807	1080.70	2.702
227.110	14841.319	1.000	0.9182	0.9182	918.16	2.295
190.923	14531.254	1.000	0.7883	0.7883	788.33	1.971
162.806	14409.998	1.000	0.6779	0.6779	677.89	1.695
135.636	14276.728	1.000	0.5700	0.5700	570.03	1.425
112.303	14191.779	1.000	0.4748	0.4748	474.80	1.187

This Download Datasheet provides a summary of the information programmed in the product.
Please refer to TM-100551 for additional information.

Figure 18. Flow Meter Calibration Data