

**PURDUE UNIVERSITY
GRADUATE SCHOOL
Thesis/Dissertation Acceptance**

This is to certify that the thesis/dissertation prepared

By Kavit Shah

Entitled

Secure Data Aggregation Protocol for Sensor Networks

For the degree of Master of Science in Electrical and Computer Engineering

Is approved by the final examining committee:

Dr. Brian King

Chair

Dr. Mohamed El-Sharkawy

Co-chair

Dr. Paul Salama

Co-chair

To the best of my knowledge and as understood by the student in the Thesis/Dissertation Agreement, Publication Delay, and Certification Disclaimer (Graduate School Form 32), this thesis/dissertation adheres to the provisions of Purdue University's "Policy of Integrity in Research" and the use of copyright material.

Approved by Major Professor(s): Dr. Brian King

Approved by: Dr. Brian King

Head of the Departmental Graduate Program

2/26/2014

Date

SECURE DATA AGGREGATION PROTOCOL FOR SENSOR NETWORKS

A Thesis

Submitted to the Faculty

of

Purdue University

by

Kavit Shah

In Partial Fulfillment of the

Requirements for the Degree

of

Master of Science in Electrical and Computer Engineering

May 2015

Purdue University

Indianapolis, Indiana

ACKNOWLEDGMENTS

I would like to express my special appreciation and thanks to my advisor Brian King who has been my teacher, guide and mentor during the entire thesis and Master's program. I am grateful to him for being a great role model for researcher and a mentor in my life. I would like to thank him for encouraging me to do thesis and allowing me to develop as a graduate student.

I would also like to thank the other members of my thesis committee: Paul Salama, Mohamed El-Sharkawy and Sangkook Lee for letting my defense be an enjoyable moment, and their brilliant comments and suggestions after the presentation.

I would also like to thank the entire academic staff of Electrical and Computer Engineering Department at Indiana University Purdue University - Indianapolis for being generous and helpful all the time.

Finally, I am thankful to my family for being patient and loving all the time. My family's financial and emotional support for me has been incredible. Their prayers for me was what sustained me thus far.

TABLE OF CONTENTS

	Page
LIST OF TABLES	vi
LIST OF FIGURES	vii
SYMBOLS	ix
ABBREVIATIONS	x
ABSTRACT	xi
1 INTRODUCTION	1
2 SENSOR NETWORKS BACKGROUND	4
2.1 Applications	4
2.2 Sensor Node Architecture	6
2.3 Energy Consumption	7
2.4 Resource Constraints	9
2.4.1 Physical Limitations	9
2.4.2 Hardware Limitations	9
2.4.3 Transmission Medium	10
2.4.4 Mobility	11
3 CRYPTOGRAPHY TOOLS	12
3.1 Symmetric Key Encryption	12
3.2 Asymmetric/Public Key Encryption	12
3.3 Hash Function	13
3.4 Message Authentication Codes	15
3.5 Digital Signatures	15
3.6 Summary	17
4 DATA AGGREGATION BACKGROUND	18
4.1 Data Aggregation	18

	Page
4.2 Bandwidth Analysis	21
4.3 Resilient And Non-Resilient Aggregate Functions	22
4.4 Security Issues	23
5 DATA AGGREGATION WITHOUT INTERNAL VERIFICATION	26
5.1 Network Assumptions	26
5.2 Attacker Model And Security Goal	27
5.3 The SUM Aggregate Algorithm of SHIA	28
5.4 Query Dissemination	28
5.5 Aggregate Commit	29
5.5.1 Aggregate Commit: Naive Approach	31
5.5.2 Aggregate Commit: SHIA's Approach	32
5.6 Result Checking	37
6 SYSTEM DESIGN	40
6.1 Introduction	40
6.2 System Design Specifications	45
7 DATA AGGREGATION WITH INTERNAL VERIFICATION	47
7.1 Data-Item	47
7.1.1 Signing and Verification of the Data-Item	49
7.1.2 Security Benefits	49
7.2 Commitment Payload	50
7.2.1 Security Benefits	51
7.3 Key Differences	52
7.3.1 Bandwidth	53
7.4 Two Ways of Forwarding Payload	53
8 OUR PROTOCOL	57
8.1 Query Dissemination	57
8.2 Commitment Tree Generation	57
8.3 Result Checking	64

	Page
8.3.1 Dissemination of Final Payload by the Base Station	64
8.3.2 Dissemination of Off-Path Values	64
8.3.3 Verification of Inclusion	68
8.3.4 Collection of Authentication codes	68
8.3.5 Verification of Authentication Codes	69
8.3.6 Detecting An Adversary	73
8.4 Analysis	75
9 CONCLUSION AND FUTURE WORK	78
LIST OF REFERENCES	79

LIST OF TABLES

Table	Page
2.1 System-on-Chip specifications for CC2538 from Texas Instruments implementing IEEE 802.15.4 standards	10
3.1 A comparison security primitives	17
4.1 Summary of Wagner's work	23
7.1 Digital Certificate	49
7.2 Data-Item Size	53
8.1 Totality of Signatures Transmitted	76
8.2 Totality of Certificates	77

LIST OF FIGURES

Figure	Page
2.1 Sensor Node Block Diagram	6
3.1 Two party communication using symmetric key encryption.	13
3.2 Two party communication using asymmetric key encryption.	14
3.3 Signing and verification of digital Signatures [25]	16
4.1 Routing River	18
4.2 Star Network	19
4.3 Palm Tree Network Topology	22
5.1 Network graph	29
5.2 Simplified Aggregation tree for network graph in Figure 5.1	30
5.3 Naive commitment tree for Figure 5.2.	33
5.4 A receives C_2 from C , (B_1, B_0) from B , D_0 from D and generates A_0 . The received commitment forest are indicated by dashed-line box.	34
5.5 First Merge: A_1 vertex created by A	35
5.6 Second Merge: A_2 vertex created by A	35
5.7 Third Merge: A_3 vertex created by A	36
5.8 Off-path values of node u are highlighted with bold outline.	38
7.1 Palm Shaped Aggregation Tree	51
7.2 Commitment Payload of Sensor Node C	51
7.3 Diamond Supply Chain.	54
8.1 Input node A has B_1 and C_1 in its forest. It aggregates these two trees and constructs A_2	59
8.2 Aggregation Tree.	59
8.3 Transformation from B 's forest to its payload. Each dashed-line box shows forest and solid-line box shows payload of the respective sensor node.	60
8.4 C 's forest aggregation creating its payload.	61

Figure	Page
8.5 A 's forest: A receives three payloads from C, B, D and constructs A_0 .	62
8.6 A 's forest: after first merge	62
8.7 A 's forest: after second merge	62
8.8 A 's payload : A sends this to the base station.	63
8.9 One Possible Commitment Tree	66
8.10 A Commitment Tree With All Unique Vertices	73

SYMBOLS

N Query nonce
 H Hash function

ABBREVIATIONS

ACK	Positive acknowledgment message
BER	Bit error rate
FSwRD	Forwarding signatures with resigning the data-items
FSwoRD	Forwarding signatures without resigning the data-items
MAC	Message authentication code
NACK	Negative acknowledgment message
SHA	Secure hash algorithm
SIA	Secure information aggregation
SHIA	Secure hierarchical in-network aggregation

ABSTRACT

Shah, Kavit. MSECE, Purdue University, May 2015. Secure Data Aggregation Protocol for Sensor Networks. Major Professor: Brian King.

We propose a secure in-network data aggregation protocol with internal verification, to gain increase in the lifespan of the network by preserving bandwidth. For doing secure internal distributed operations, we show an algorithm for securely computing the sum of sensor readings in the network. Our algorithm can be generalized to any random tree topology and can be applied to any combination of mathematical functions. In addition, we represent an efficient way of doing statistical analysis for the protocol. Furthermore, we propose a novel, distributed and interactive algorithm to trace down the adversary and remove it from the network. Finally, we do bandwidth analysis of the protocol and give the proof for the efficiency of the protocol.

1. INTRODUCTION

Mark Weiser of Xerox PARC [1] invented the term ubiquitous computing in 1988 today which is known as Internet of Things (IoT). It is the scenario in which computing is everywhere. It represents the scenario where devices that do not look like computers have computational power. For example, street lights, door locks, kitchen utensils and clothing have data processing power in them. The synergy between these devices make the network do meaningful work. A wireless infrastructure is essential for communications in such networks.

Kevin Ashton is a British technology pioneer who co-founded the Auto-ID Center at the Massachusetts Institute of Technology, which created a global standard system for RFID and other sensors. He is known for inventing the term Internet of Things (IoT) to describe a system where the Internet is connected to the physical world via ubiquitous sensors [3]. IoT means putting all kinds of devices on the Internet and gaining efficiency from it. For example, Uber is a company built around location awareness [4]. An Uber driver is a taxi driver with the real-time location awareness. An Uber passenger knows when the taxi will show up. It is about eliminating slack time and worry. It connects passengers, taxi drivers, smart phones and GPS in a way that it provides an efficient and flexible way of transportation. In addition to that, the Medical device manufacturers want medical instruments to report to analyze the data and report it to a nursing station in timely fashion. In such scenario, each device becomes a network node. It takes advantage of the services offered by other nodes in the network, instead of duplicating their work [2]. At the core of ubiquitous computing and IoT, are the sensors generating data and wireless network providing transmission medium for communications. Collectively, we refer these concepts as Sensor Networks which enable economically viable solutions to a variety of applications.

In sensor networks, the sensors collect raw data, and the data is processed by more powerful machines which converts the raw data into the information. Based on the derived information an important action is taken. The error at any stage in the process can create catastrophic situations. For example, speed sensor failure led to crash of Air France flight - Airbus A330-203 AF 447 on 1st June 2009. France's Bureau of Investigation and Analysis (BEA) released the Airbus final report [5]. According to an official report " the pilots could not reclaim control as the plane dropped out of the sky at a rate of 10,000 feet per minute. The flight's black boxes which were found intact at the bottom of the Atlantic in early May. Their analysis reveals the terrifying details of Air France flight 447's literal dropping out of the sky. The co-pilots encountered problem with the speed sensors four hours and 10 minutes into the flight. The flight was operated by autopilot when the pilot took a routine rest according to the schedule and ran out of the cockpit. They were knowingly headed into a turbulent and storm-ridden spot over the Atlantic, and the black boxes show the pilots attempted to maneuver around the storm slightly. For nearly a minute, as the speed sensors jumped, the pilot was not present in the cockpit. By the time the pilot returned, the plane had started to fall at 10,000 feet per minute while violently rolling from side to side. The plane's speed sensors never regained normal functionality. The plane began its three-and-a-half minute freefall and plunged into the Atlantic nose-up. This accident killed all 228 passengers in the flight. The findings coincide with investigators' earlier theory that the sensors, known as pitot tubes, malfunctioned, possibly because of ice at such a high altitude." The sensor failure error generated the bad data, resulting in the flight crash. The bad data can be generated by attacking the sensor network and generating false data purposefully by an adversary. In addition to, the small error in the system design could result in significant bad consequences. For example, the recent data breach attack on the company Anthem, revealed Social Security numbers and lots of private and secure details of approximately 80 million customers of the company. It is considers as one of the biggest data breach in the of medical customer data in the United States history [6].

In sensor networks, sensors are so blended into the physical world that they are hard to distinguish from the physical objects. The sensors may blend into the physical world so well that people will lose awareness of the computations happening behind the scenes. To hide complexity is good from the usability perspective but it is a major liability. This is a serious problem. Weiser [7] acknowledges: “If the computational system is invisible as well as extensive, it becomes hard to know what is controlling what, what is connected to what, where information is flowing, how it is being used, what is broken and what are the consequences of any given action?”. The networks where computing is invisible, and it is unclear who is responsible for what, detecting an adversary is a challenging task. We think that the detecting an adversary is necessary in sensor networks for countermeasures (a posteriori remedies). It is essential for the longevity of the sensor network. Hence, we focus on designing the protocol which helps detect an adversary in the sensor networks.

2. SENSOR NETWORKS BACKGROUND

Sensor networks are becoming ubiquitous in our day to day life. It is a scenario in which network and computers are extremely inexpensive objects and they are surrounded to real people all the time [2]. In this chapter, we introduce sensor networks and its applications, we define basic terminologies and then we discuss major barriers to achieve security in sensor networks.

2.1 Applications

In sensor networks, thousands of sensor nodes may interact with the physical world and collectively monitor an area, generating a large amount of data to be transmitted and reasoned about. With the recent advances in hardware technologies of sensors, we can use tiny and cheap sensor nodes to obtain significant amount of useful data about physical world. For example, we can use them to discover temperature, water quality, lightning condition, humidity and pressure levels. We can also use them to know certain characteristics of objects such as speed, direction, and size. These versatile types of sensors, allow us to use sensor network in a wide variety of scenarios. For example, sensor networks are used in military, environmental monitoring, health care, scientific data collection, emergency fire alarm systems, traffic monitoring, wildfire tracking, wildlife monitoring and many other applications.

Military Application Sensor networks can be used for enemy tracking, battlefield surveillance or target classification [9]. For example, *Palo Alto Research Center* tries to spot “interesting” vehicles (the vehicles marked specially) using nodes equipped with microphones or steerable cameras [10]. The goal is to synchronize the sensor network to sense the track of a moving object with minimum information loss about the track of a moving object.

Environmental Monitoring Sensor networks can be utilized to monitor a geographical location. For example, *Meteorology and Hydrology in Yosemite National Park* [11], a sensor network was deployed to monitor the water system across and within the Sierra Nevada. The goal was to collect the data and derive information on natural climate fluctuation caused due to global warming. It also provided information on the increasing needs of water consumers. Research of the water system in the Sierra Nevada is difficult, because of its geographical structure. Sensor networks can be very useful in such situations as they can operate with little or no human intervention.

Health Care Sensors can be used to monitor the patients around the clock. They can report various statistics to the doctors and nurses regarding patients health. Also, it can send reminders to them to take care of the patient periodically. The most important criteria for the such networks are security and reliability. Because based on the sensor readings, doctors decide what treatment or what medicine to prescribe to the patients. If those readings are modified by an adversary then the consequences might be lethal to the patients.

Sustainable Mobility Sensor networks can be used to build digitally connected and coordinated vehicles. With the driver less cars from companies like Google, autonomous vehicle systems seems the future of transportation. Autonomous vehicle systems [12] describes how various various technologies in addition to the sensor networks is used in making the sustainable mobility.

The applications of the sensor networks are enormous. The application platform of a sensor network determines the design of the sensor nodes, the network protocol and security architecture. As far as we know, there is no general architecture for such design. Therefore, developing a protocol for sensor networks can certainly be challenging.

2.2 Sensor Node Architecture

Sensor networks consists of an individual sensor node and the construction of each node depends on the application. The major components of the sensor nodes are shown in Figure 2.1 [15].

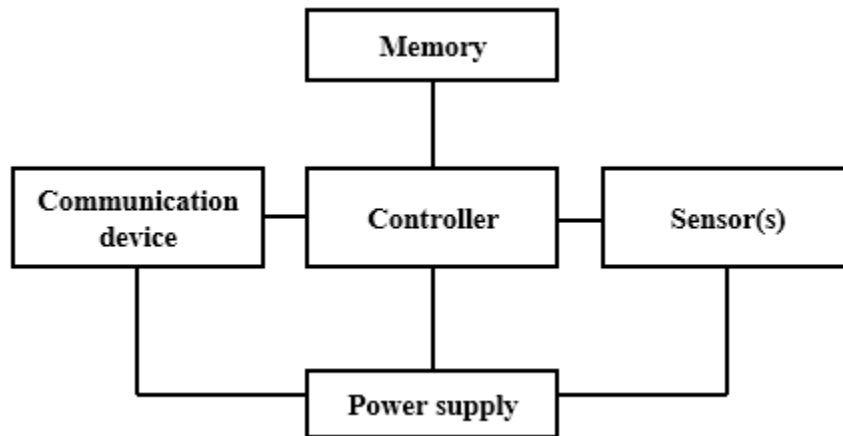

Fig. 2.1.: Sensor Node Block Diagram

Controller is the Central Processing Unit (CPU) of the node. It is responsible for collecting data from the sensors and processing it to deriving useful information from it. It also decides nodes for end to end communications and affects the actuator's behavior. It executes variety of algorithms, ranging from time-critical signal processing and communication protocols to application algorithms.

Communication Device is utilized for trans receiving data between end hosts at radio frequency. Radio Frequency(RF)-based communication is widely used in sensor networks. RF based communications does not require line of sight between sender and receiver. It also provides relatively long range communications capabilities and high data rates. It has an acceptable error rates at reasonable energy consumption. All these characteristics, best fits the requirements of many sensor network applications. The most important function for these devices are to convert a bit stream to radio waves and vice versa.

Sensors are the nodes generating raw data to be transmitted and analyzed by the network. *Passive sensors* can measure a physical quantity without affecting the environment at the point of deployment. For example, vibration, chemical sensors sensitive for given substances and smoke detectors. *Active sensors* actively probes the environment and generates raw information to be analyzed. For example, a radar sensor or some types of seismic sensors creates shock waves by small explosions into the sea to get the details about the earth. These are very specific explosions and requires quite special permissions to carry out such experiments.

Power Supply of Sensor Nodes is an important system component, too. Sensor nodes can be powered by using normal AA battery which stores about 2.2 - 2.5 Ah at 1.5 V. To increase the longevity of the nodes and wireless sensor networks we can use energy from a nodes environment “energy scavenging”. For example, *Photovoltaics* effect is used in the solar cells, can be applied to power supply module of the sensor nodes. *Temperature gradients* effect utilizing the differences in temperature can be converted to electrical energy and can be used to power sensor nodes.

The Memory Component is fairly straightforward. Random Access Memory (RAM) can be used to store sensor readings, and temporary data. The operating system code can be stored in Read-Only Memory (ROM). It is important to dimension RAM and ROM precisely, to reduce the manufacturing cost and power consumption.

2.3 Energy Consumption

The sensor network’s lifetime can be maximized by minimizing the power consumption of communication devices or trans receiver of the sensor nodes. The trans receiver is responsible for all the wireless communications between nodes. To estimate the power consumption, we have to consider the communication and compu-

tation power consumption. The trans receiver's energy dissipation depends on two main parameters [17]. The first is $E_{elec}(J/b)$, the energy dissipated to run the transmit or receive electronics. The second is $\varepsilon_{amp}(J/m^2b)$, the energy dissipated by the transmit power amplifier to achieve an acceptable signal to noise ratio E_b/N_o at the receiver. We assume the d^2 energy loss for transmission between sensor nodes since the distances between sensors are relatively short [18]. To transmit a k - bit packet at distance d , the energy dissipated is:

$$E_{tx}(k, d) = E_{elec} \cdot k + \varepsilon_{amp} \cdot k \cdot d^2 \quad (2.1)$$

and to receive the k - bit packet, the radio expends

$$E_{rx}(k) = E_{elec} \cdot k \quad (2.2)$$

For μAmp wireless sensor, $E_{elec} = 50nJ/b$ and $\varepsilon_{amp} = 100pJ/m^2b$.

Trans receiver can be put into different states to save energy [15]. It can be in either transmit or receive state and energy consumption of those states are describe above. It can be in Idle state where it is ready to receive packet but is not currently receiving anything. It can be in Sleep state where majority of the parts are switched off, and is not able to receive immediately. To sustain the sensor network for longer times all aspects of the sensor network should be efficient. For example, the networking algorithm for routing should be such that it minimizes the distance d between the nodes. The signal processing algorithm should be such that it process the networking packets with less computations. It is shown in [17] that by using Fast Fourier Transform (FFT) algorithm in the devices requires less communication between the sensor nodes. To minimize the energy dissipation, a processor should operate at the lowest possible voltage for a given clock frequency.

2.4 Resource Constraints

We introduce the parameters which should be taken into account while designing secure protocol for sensor networks. These parameters can constrain the protocol designer's choices within the protocol.

2.4.1 Physical Limitations

Sensor nodes are often used in open, hostile and unattended environments. They are vulnerable to physical attacks due to the lack of physical security available in their environment. It allows an adversary to gain the secret information from a compromised sensor node. An adversary can reprogram the sensor node with virus (malicious software). The compromised node then report an arbitrary false sensor readings to its parent node in the tree hierarchy, making the sensor readings unreliable and irrelevant. These attacks become more damaging when multiple adversaries succeeds in inserting false data into the network which may cause catastrophic consequences [19].

2.4.2 Hardware Limitations

As far as we know, one of the first hardware platform for developing sensor network application is MICA [20] developed by University of Berkeley. Another popular platform is Mote from Intel [21]. Due to lower manufacturing cost of sensor nodes, they have low speed processor, limited storage, a short range trans receiver. For example, the major specifications for the latest ZigBee chip supporting IEEE 802.15.4 standard, CC2538 from Texas Instruments are shown in Table 2.1. This chip can do most of the security algorithms but has really little amount of memory storage. It has limited output power which constraints its transmission range which forces us to use multi-hop routing in the network as one node can not communicate with the node outside of its transmission range. These hardware limitations can constrain protocol designer's choice of algorithms for applications.

Table 2.1.: System-on-Chip specifications for CC2538 from Texas Instruments implementing IEEE 802.15.4 standards

Device Type	Wireless Micro controller
Frequency	2.4GHz
Processor Integration	ARM Cortex-M3
Flash	Up to 512 KB
RAM	Up to 32 KB
Security	AES-128/256; SHA2; RSA
RX Current	20 (mA)
Output Power	7 (dBm)
Data Rate(Max)	250 kbps
Type of Battery	AAA; AA; Rechargeable(Li-ION)

2.4.3 Transmission Medium

In sensor networks, a group of sensor nodes (or processors) communicate over the radio (e.g., Blue-tooth, WLAN). Traditionally, wireless mediums have issues due to synchronization, hidden station and expose station terminal problems, distributed arbitration, directional antennas, bandwidth limitations, higher error rate, security, scalability etcetera. For example, wireless networks have approximately 10^6 times higher bit error rate (BER) than wired networks which causes frequent link loss and then path loss. Hence, making unstable routing in the network. Higher BER creates higher collision rate in the network, generating higher overhead of retransmission and lowering the channel utilization and the throughput of the network. This kind of transmission medium with constrained resources makes it challenging to design the reliable networking protocol as we have to consider all the possible retransmissions.

2.4.4 Mobility

As we know, sensor nodes communicate via radio and the availability of the transmission medium changes over time due to link failure, bandwidth limitations or change in network topology. Nodes may be mobile creating the instability of the network link, which require the reconfiguration and special protocol to redesign the network. The mobility issue makes difficult to do the routing in the network with the directional antennas in place. It also requires network to be agile enough to do the reconfiguration for the newer network topology. It impedes while doing the quality of service in the network.

All these parameters combined contributes to making strong assumptions on the network topology while designing the protocol for sensor networks.

3. CRYPTOGRAPHY TOOLS

The word cryptography means “secret writing”. It is the art and science of hiding the information from malicious or unauthorized parties. Cryptanalysis is the science of cracking cryptography schemes. Formally, the fundamental components of cryptography is a cryptosystem [22].

Definition 3.0.1 *A cryptosystem is a system consisting of 5-tuple $(\mathcal{E}, \mathcal{D}, \mathcal{M}, \mathcal{K}, \mathcal{C})$, where $\mathcal{E} : \mathcal{M} \times \mathcal{K} \rightarrow \mathcal{C}$ is the set of enciphering functions, and $\mathcal{D} : \mathcal{C} \times \mathcal{K} \rightarrow \mathcal{M}$ is the set of deciphering functions. \mathcal{M} is the set of plaintexts, \mathcal{K} is the set of keys, \mathcal{C} is the set of ciphertexts,*

3.1 Symmetric Key Encryption

An encryption scheme made with the sets of encryption set $\{E_e : e \in \mathcal{K}\}$ and decryption transformations $\{D_d : d \in \mathcal{K}\}$, where \mathcal{K} is the key space. The encryption scheme is said to be *symmetric-key* if for each associated encryption and decryption key pair (e, d) , it is computationally “easy” to determine d given e , and to determine e from d [23]. In many major symmetric-key schemes $e = d$. The communication protocol between two parties Alice and Bob, using symmetric key encryption scheme is shown in Figure 3.1. The major road block with symmetric key system is to find an optimal solution to agree upon for securely doing the exchange keys between two entities, which is known as *key-distribution problem* [23].

3.2 Asymmetric/Public Key Encryption

Consider an encryption scheme where $\{E_e : e \in \mathcal{K}\}$ is a set of encryption transformations, and $\{D_d : d \in \mathcal{K}\}$ be the set of corresponding decryption transformations,

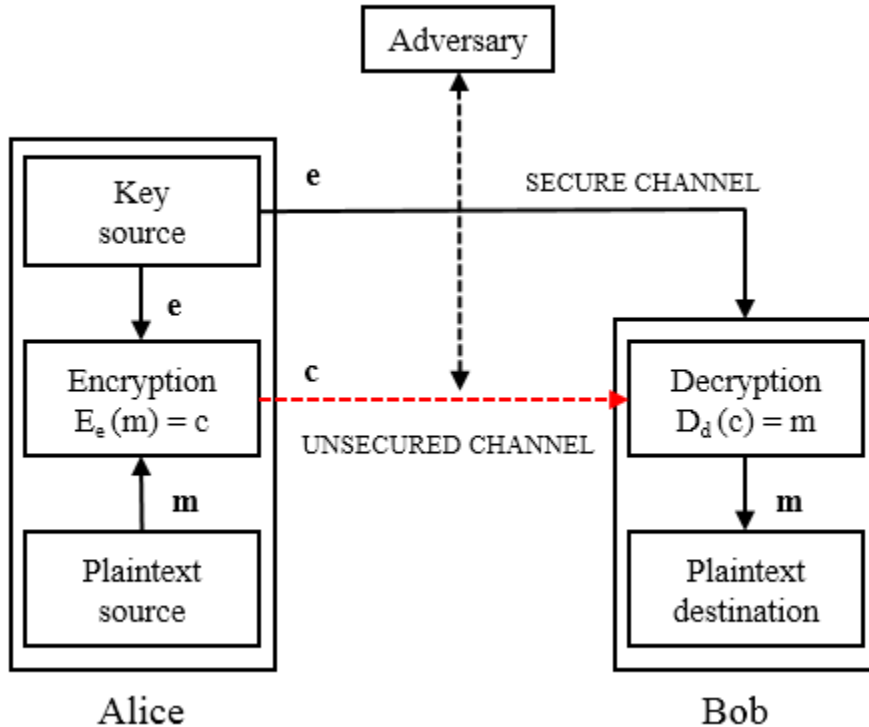

Fig. 3.1.: Two party communication using symmetric key encryption.

where \mathcal{K} is the key space. Any pair of related encryption-decryption transformations (E_e, D_d) and assuming that each pair has the property that knowing E_e it is computationally infeasible, given a random cipher text $c \in \mathcal{C}$, to find the message $m \in \mathcal{M}$ such that $E_e(m) = c$. It implies that given the encryption key e , it is impossible for an adversary to determine the related decryption key d . This is contrary to the symmetric key schemes in which e and d are the same [23]. The communication protocol between two parties Alice and Bob, using asymmetric key encryption scheme is shown in Figure 3.2.

3.3 Hash Function

A hash function takes a message as its input and outputs a fixed length message called hash code. The hash code represents a compact image of the message like a

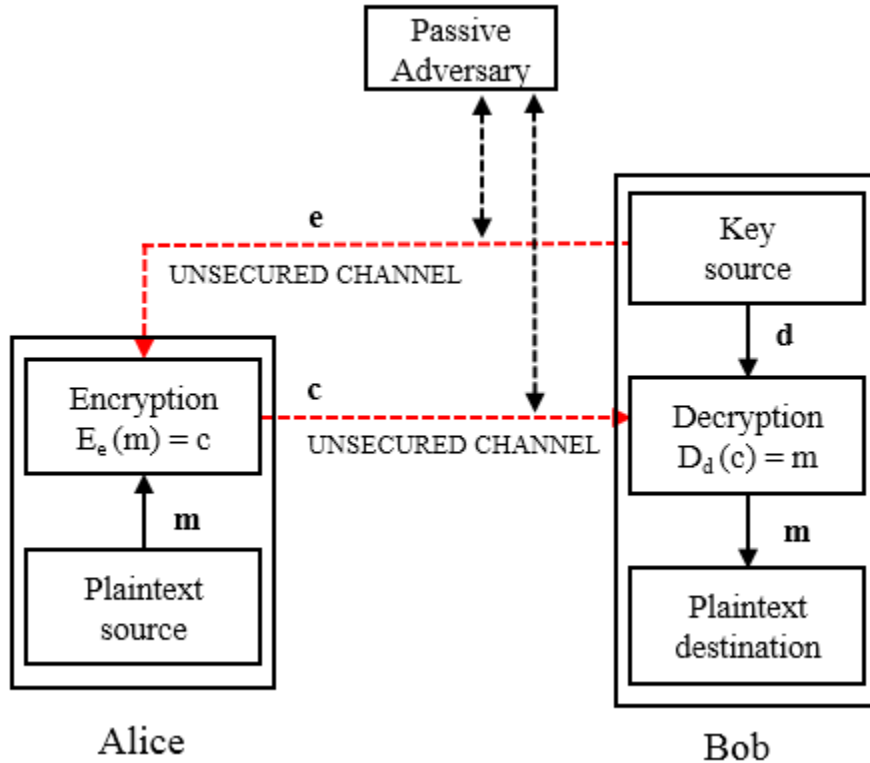

Fig. 3.2.: Two party communication using asymmetric key encryption.

digital fingerprint. Hash functions are essential mathematical tools to achieve data integrity. A hash function should have the security properties like Compression, Ease of computation, Preimage resistance, Collision resistance. Compression means a hash function converts an input of random finite bit length, to a fixed bit length n . Ease of computation means given the hash function and input, it is easy to compute the output. Preimage resistance means given the outputs, it is impossible to discover any input whose hashed output maps to the given output. Collision resistance means it is hard to construct two unique inputs which hashes to the same value. SHA-256, is a 256-bit hash and assures 128 bits of security against collision attacks [24]. For most of the applications 128 bits security is adequate.

3.4 Message Authentication Codes

A Message Authentication Code (MAC) is a group of hash functions parameterized by a secret key k , also known as keyed hash function (h_k). It should have the security properties like Ease of computation, Compression, Computation-resistance similar to the described for hash functions. If all these properties are not satisfied then a MAC algorithm can be attacked with MAC forgery.

3.5 Digital Signatures

A digital signature is a cryptographic scheme providing the security services of the authenticity, integrity and non-repudiation of a digital message. A valid digital signature provides a proof to a recipient that the message was created by an authentic sender, such that the sender cannot deny having created and sent the message. It also guarantees that the message was not altered during the transmission. A Digital Signature scheme consists of the following:

1. a plain text message space \mathcal{M} (set of strings over alphabets)
2. a signature space \mathcal{S} (set of possible signatures)
3. a signing key space \mathcal{K} (set of possible keys for signature generation) and a verification space \mathcal{K}' (a set of possible verification keys)
4. an efficient key generation algorithm $\text{Gen} : N \rightarrow \mathcal{K} \times \mathcal{K}'$
5. an efficient signing algorithm $\text{Sign} : \mathcal{M} \times \mathcal{K} \rightarrow \mathcal{S}$
6. an efficient verification algorithm $\text{Verify} : \mathcal{S} \times \mathcal{M} \rightarrow \{\text{true}, \text{false}\}$

For any secret key $s_k \in \mathcal{K}$ and any $m \in \mathcal{M}$, the message m is signed using key s_k as follows:

$$s = \text{Sign}_{s_k}(m) \tag{3.1}$$

For any s_k let p_k denote public key and for all $m \in \mathcal{M}$ and $s \in \mathcal{S}$, s as follows:

$$\text{Verify}_{p_k}(m, s) = \begin{cases} \text{true} & \text{with probability of 1} & \text{if } s = \text{Sign}_{s_k}(m) \\ \text{false} & \text{with overwhelming probability} & \text{if } s \neq \text{Sign}_{s_k}(m) \end{cases} \quad (3.2)$$

where the probability space is determined by the $\mathcal{M}, \mathcal{S}, \mathcal{K}, \mathcal{K}'$ and perhaps the signing and verification algorithms. The “overwhelming probability” for the signature scheme determines the probability that the scheme allows for a forgery. In Figure 3.3, we show the steps for signing and verifying the hashed message [25]. The message is hashed

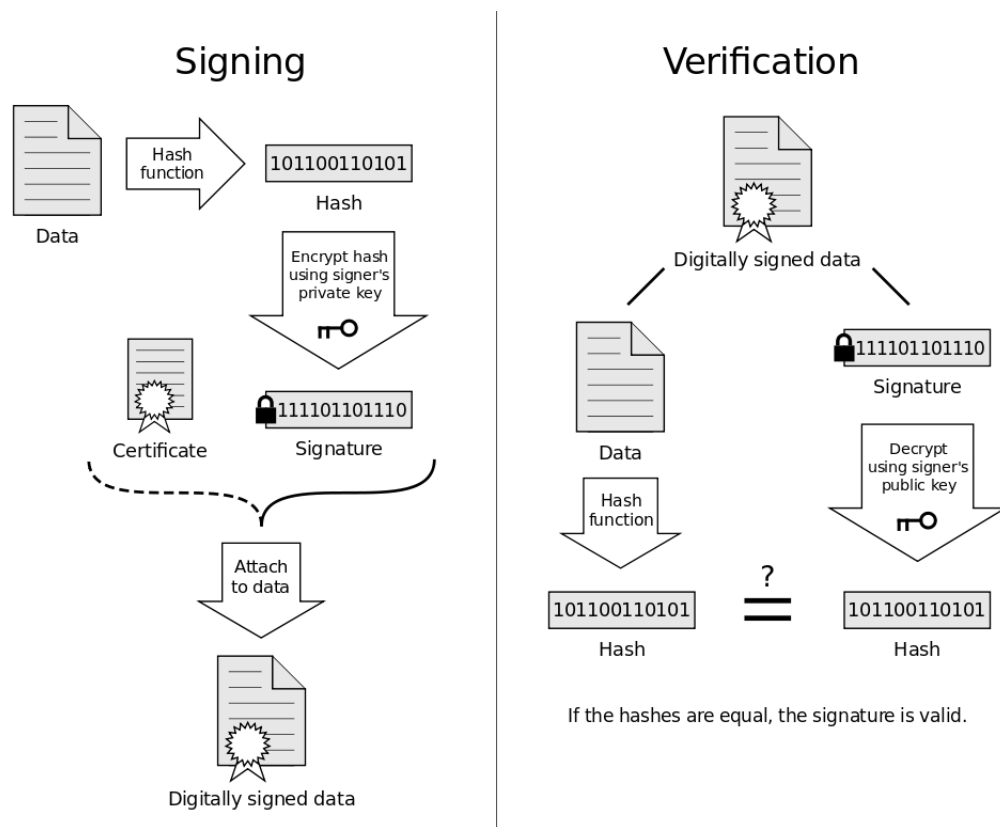

Fig. 3.3.: Signing and verification of digital Signatures [25]

before its being signed to reduce the message size. If the message is not hashed before signing then the signature can be longer than the message which is problematic for the longer messages.

In the Digital Signature scheme only the owner of the secret key can generate a valid signature. The digital signature is easily verified by other parties as long as they know the public key. The digital signature is not only tied to the signer but also to the message that is being signed. Digital signatures do not encrypt the message. However, if necessary, a signed message can be encrypted after it is signed.

3.6 Summary

Three different integrity-protection mechanisms HASH, MAC, Signature can be summarized in a matrix like Table 3.1 [2]. These primitives differ from the parties' capabilities of generating and verifying the code which depends on the application.

Table 3.1.: A comparison security primitives

	Who can generate it	Who can verify it
Hash	Everyone	Everyone
MAC	Holders of secret	Holders of secret
Signature	Holder of secret	Everyone

4. DATA AGGREGATION BACKGROUND

Data aggregation is an important primitive for wireless routing in sensor networks. The basic concept is to compress the data coming from different sources enroute eliminating redundancy, minimizing the number of transmissions and thus saving energy [26]. The necessary functionality of sensor networks is the ability to reply the queries initiated by the base station. For example, in Figure 4.1 [27] the base station who initiates the query to the sensor network might be at the end of the river. The sensor nodes may lie on both sides of the river and they have to response to the queries of the base station. The transceiver module in the sensor nodes has a limited transreceiving range. So, the sensor nodes cannot communicate to the base station in peer-to-peer fashion. The sensor nodes have to communicate via hop-by-hop to the base station. This resource constraint forces us to design distributed protocol for sensor networks.

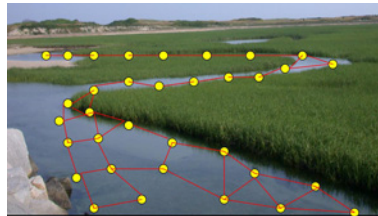

Fig. 4.1.: Routing River

4.1 Data Aggregation

The sensor nodes in the network often have limited resources, such as computational capability, memory storage, transmission capacity and the most important, battery power. The wireless data communications between nodes consume a large

portion of the total energy consumption. In-network data aggregation techniques allow the sensor nodes to aggregate the data before sending it to their parents. This technique reduces the wireless communication happening between the nodes and the overall energy consumption in the network. For instance, in-network data aggregation of the SUM function can be executed as follows. All the intermediate sensor nodes in the network, receives the sensor readings from all of their children. They aggregate all those readings by applying the summation function to those readings. A network, which has the star topology, shown in Figure 4.2. The root of the tree receives the

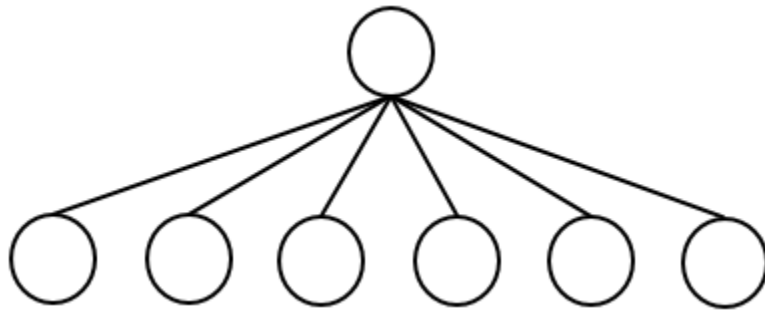

Fig. 4.2.: Star Network

following sensor readings $S_1(10), S_2(14), S_3(12), S_4(15), S_5(11), S_6(17)$. The root has its own reading of $S_0(15)$. The root node aggregates these seven readings and creates an aggregated result as follows:

$$S = \sum_{i=0}^6 S_i \quad (4.1)$$

Now, instead of sending all those sensor readings one at a time to its parent, it can send one aggregated sensor reading. In this example the aggregate function is summation, but it can be replaced with other statistical functions such as average, median, count etcetera with little or no modification.

According to [28], data aggregation can be defined as follows. Let's consider a sensor network with n sensors collecting data. The collected data will be transmitted to the base station using hop-by-hop communication. The base station aggregates the received data and creates useful information by analyzing it. This can be written

as $f(x_1, x_2, \dots, x_n)$ where x_1, x_2, \dots, x_n are the sensor readings. The function f is some mapping $f : \mathcal{D}_1 \times \mathcal{D}_2 \times \dots \times \mathcal{D}_n \rightarrow I$, where \mathcal{D}_i represents sensor i 's domain and I represents the set of all possible information. Thus the goal is to compute the information as follows:

$$y = f(x_1, x_2, \dots, x_n) \tag{4.2}$$

It is shown that the energy savings achieved by in-network data aggregation are significant [29]. The in-network data aggregation approach requires the sensor nodes to do more computations. But studies have shown that wireless communication of data transmission requires more energy than local computation of the data. In-network data aggregation is an efficient and a widely used approach for saving bandwidth by doing less wireless communications between sensor nodes and ultimately giving longer battery life to sensor nodes in the network.

We define the following terms to help us define the goals of in-network data aggregation.

Definition 4.1.1 [30] ***Payload** is the part of the transmitted data which is the fundamental purpose of the transmission, to the exclusion of information sent with it such as meta data solely to facilitate the delivery.*

Definition 4.1.2 *For a given node **Information rate** is the ratio of the number of sent payloads over the received payloads.*

The goal of the aggregation process is to achieve the lowest possible information-rate. In the following sections, we show that lowering information rate makes the intermediate sensor nodes (aggregator) more powerful. In addition to that, it makes aggregated payload more fragile and vulnerable to various security attacks. Hence, to provide security services to data aggregation protocol is very critical.

4.2 Bandwidth Analysis

Congestion is a widely used parameter while doing bandwidth analysis of networking applications. The congestion for any given node is defined as follows:

$$\text{Node congestion} = \text{Edge congestion} \cdot \text{Fanout} \quad (4.3)$$

Congestion is a useful factor while analyzing sensor network as it quantifies how fast the sensor nodes will use their battery power [31]. Some nodes in the sensor network have more congestion than the others, the highly congested nodes are the most important to the network connectivity. For example, the nodes closer to the base station are essential for the network connectivity. The failure of the highly congested nodes may cause the sensor network to fail even though most of the nodes in the network are alive. Hence, it is desirable to have a lower congestion on the highly congested nodes even though it costs more congestion within the overall sensor network. To distribute the congestion uniformly across the network, we can construct an aggregation protocol where each node transmits a single payload as Definition 4.1.1 to its parent in the aggregation tree. In this approach, the fanout (δ) depends on the given aggregation tree. For example, in the aggregation tree shown in Figure 4.2, with n nodes, organized in the star tree topology, we see the congestion is $O(n)$. For the network organized in the palm tree topology, as shown in Figure 4.3, the congestion is $\theta(1)$. This approach can create some highly congested nodes in the aggregation tree which is undesirable. In most of the real world applications, we cannot control δ as the aggregation tree is random. Hence, it is desirable to have uniform distribution of congestion across the aggregation tree.

Even though network topology can be random, in our observation, palm tree, star tree, binary tree are widely used network topologies to do the performance analysis. In the following chapters, we describe how to run our protocol for any random aggregation tree. In the end, we do bandwidth analysis of the protocol for star, palm and binary trees.

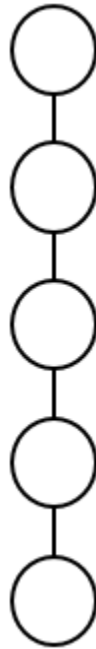

Fig. 4.3.: Palm Tree Network Topology

4.3 Resilient And Non-Resilient Aggregate Functions

Wagner [32] uses statistical estimation theory to quantify the effects of direct data injection on different aggregate functions.

Definition 4.3.1 [33] A **Direct Data Injection** attack occurs when an adversary modifies the data readings reported by the nodes under its direct control, under the constraint that only legal readings in $[0, r]$ are reported.

Definition 4.3.2 [32] An aggregation function f is (k, α) -resilient (with respect to a parameterized distribution $p(X_i|\theta)$) if $rms^*(f, k) \leq \alpha \cdot rms(f)$ for the estimator f .

The author's intuition is that the (k, α) -resilient functions are the ones that can be computed with integrity in the presence of up to k malicious nodes (for small values of α). According to this study which measures the effects of direct data injection on different aggregate functions, concludes that the aggregates truncated SUM and AVERAGE can be resilient under such attacks.

Table 4.1.: Summary of Wagner’s work

Aggregate(f)	Security Level
minimum	insecure
maximum	insecure
sum	insecure
average	insecure
count	acceptable
$[l, u]$ -truncated average	problematic
5% -trimmed average	better
median	much better

4.4 Security Issues

The aggregation schemes can be compared with compression schemes. “Lossless data compression” [34] produces a compressed file from which the original data can be recovered exactly. Facsimile uses lossless data compression. However, lossless data compression schemes are limited in the compression rates they can achieve. “Lossy data compression” [34] schemes produces a compressed file from which only an approximation to the original information can be recovered. Much higher compression ratios are possible. The aggregation scheme will be a *lossy data compression* because once the base station receives the final aggregated value it can not create the original sensor readings of the sensor nodes. It is very important that the base station has very high confidence in the received final aggregated value. For example, in Equation 4.2 Sensor II’s reading is changed from x_2 (the “true reading”) to x'_2 by an intermediate aggregator, then an aggregate node computes y' . It is very likely that $y' \neq y$ where y is the true information if the true reading was counted. The base station takes an action based on the received information y' . It could be dangerous to act using false data y' .

As we know, in-network data aggregation technique saves bandwidth by transmitting less payloads between sensor nodes thus increasing the lifetime of the network. Designing one such protocol for the sensor networks poses a numerous challenges due to resource limitations and inherent characteristics discussed in the previous chapter. Moreover, this technique empowers intermediate aggregate sensor nodes in the network by allowing them to control certain portion of the network. A malicious intermediate sensor node who does aggregation over all of its descendants payloads, needs to tamper with only one aggregated payload instead of tampering with all the payloads received from its descendants. Thus, a malicious intermediate sensor node needs to do less work to skew the final aggregated payload. An adversary controlling few sensor nodes in the network can cause the network to return unpredictable payloads, making an entire sensor network unreliable. Intermediate sensor nodes adversarial power is proportional to their number of descendants.

While applying the data-aggregation techniques the integrity of the sensor readings becomes more valuable. As one or few faulty sensor readings can deviate the final aggregated result. For example, National Snow and Ice Data Center on June 3, 2008 [35] reported that Arctic sea ice extent had declined as the summer approaches. Everyday ice extents in May continued to be below the long-term average. Eventually it reached the all time low levels. The spring ice cover was thin caused by the formation of several polynyas in the ice pack. The Defense Meteorological Satellite Program (DMSP) F13 [36] satellite, which had been central to their Arctic sea ice analysis for the past several years, is nearing the end of its mission. As the standard data practice, they have transitioned to a newer sensor, in that case the DMSP F15 [37]. The DMSP F15 had the same type of sensor as the DMSP F13. NSIDC had done preliminary inter calibration to assure consistency with the historical record. They said that due to the inter calibration errors the final reported ice extent values might differ on average $\pm 30,000$ square kilometers per preliminary number reported. The faulty sensor readings can be caused due to malfunctioning sensors, the active attacks on true sensor readings or incorrect interpretations of the data, which can generate false

data and cause catastrophic situations. Hence, it is necessary to take account for false data in your input and take countermeasure while using data-aggregation techniques.

Despite the fact that in-network aggregation makes an intermediate sensor nodes more powerful and aggregated value more vulnerable to various security attacks, some aggregation approaches requires strong network topology assumptions or honest behaviors from the sensor nodes. For example, in-network aggregation schemes in [31, 38] assumes that all the sensor nodes in the network are honest. Secure Information Aggregation (SIA) of [39] enables secure data aggregation such that the base station accepts the data with high probability if the aggregated result is within an acceptable range. The base station can detect malicious activity with overwhelming probability and rejects all the out of range results. The SIA provides probabilistic security for the network topology with a single-aggregate model.

Secure hierarchical in-network aggregation (SHIA) in sensor networks [33] presents the first secure sensor network data aggregation protocol for random networks single as well as multiple adversaries. We discuss the details of the protocol in the next chapter. SHIA bounds the adversary's capacity to tamper with the aggregation result with the tightest bound possible. But it does not help detecting an adversary in the network. We build our work on the foundation of SHIA, which allows to track down the adversary and remove it from the network.

5. DATA AGGREGATION WITHOUT INTERNAL VERIFICATION

Secure hierarchical in-network aggregation (SHIA) [33] presents the first and provably secure sensor network data aggregation protocol without internal verification. It is designed for general networks with single or multiple adversaries. Our work enhances SHIA, by making it communication efficient, adds new security services to the protocol, achieves similar security goals with non-resilient aggregation functions and efficient ways of analyzing the protocol. In this chapter, we summarize the important parts of SHIA and relevant terms, to build the foundation to describe our protocol in the following chapters.

5.1 Network Assumptions

We assume a multi hop network with a set $S = \{S_1, \dots, S_n\}$ consisted of n sensors where all sensors are within communication range and generating heartbeats. The rooted tree topology is constructed from the given network graph which can be constructed using any tree generation algorithms. The trusted base station is located in the outskirts of the network. The base station has more computation power, storage capacity than the sensor nodes in the network ¹. The base station is aware of the total number of sensor nodes in the network and the network topology. It also has the capacity to directly communicate with every sensor node in the network using authenticated broadcast. All the wireless communications between the sensor nodes are peer-to-peer. We assume absence of the local wireless broadcast in the network. Each sensor node S has a unique ID and it shares a unique secret symmetric key K_S with the base station. The symmetric keys enable message authentication between the

¹SHIA names the base station as the querier and the root of the tree as the base station.

sensor node and the base station. It also allows data encryption in the network if the data confidentiality is required. All the sensor nodes are capable of doing symmetric key encryption and symmetric key decryption. They are also capable of computing collision resistant cryptographic hash function.

5.2 Attacker Model And Security Goal

We assume that the malicious or compromised node can misconduct in any random way. We assume that the adversary has computational resources no more than polynomial in terms of the security parameter. Hence, it is called polynomially bounded attacker model [39]. It can full control over any fraction of nodes in the network. For example, the adversary can tamper with the reported data by the sensors under its control and forward false aggregated result. In addition to that, an adversary could ignore its children's reading completely and aggregate fictitious values and forward the garbage aggregated result. In such a case, the base station receives the inaccurate aggregated data. Many applications rely on the information received or derived by the base station to take critical decision and act upon it.

We concentrate on stealthy attacks. According to [39] in stealthy attacks “an adversary has the goal of to make the base station accept false aggregation results, which are significantly different from the true results determined by the measured values, while not being detected by the base station.” In this setting, denial-of-service (DoS) attacks such as not responding to the queries or always responding with negative acknowledgment at the end of verification phase clearly indicates to the base station that something is wrong in the network and therefore is not a stealthy attack. One of the security goals of SHIA is to detect the stealthy attacks. One of the security goals of our work is to detect an adversary who caused the stealthy attacks and remove it from the network to prevent these attacks in the future.

Without precise knowledge of application, the direct data injection attacks are indistinguishable from the malicious sensor readings. The goal of SHIA is to design an optimally secure aggregation algorithm with only sublinear edge congestion.

Definition 5.2.1 [33] *An aggregation algorithm is optimally secure if, by tampering with the aggregation process, an adversary is unable to induce the base station to accept any aggregation result which is not already achievable by direct data injection.*

5.3 The SUM Aggregate Algorithm of SHIA

In this algorithm, the aggregate function f is summation meaning that we want to calculate $a_1 + a_2 + \dots + a_n$, where a_i is the reading of the sensor node i . The algorithm has the following three main phases.

Query dissemination, initiates the aggregation process.

Aggregate commit, initiates the commitment tree generation process.

Result checking, initiates the distributed, interactive verification process.

5.4 Query Dissemination

Prior to this phase, an aggregation trees is created using a tree generation algorithm. We can use any tree generation algorithm as this protocol works on any aggregation tree structure. For completeness of this protocol, one can use Tiny Aggregation Service (TaG) [29]. TaG uses broadcast message from the base station to initiate a tree generation. Each node selects its parent from whichever node it first receives the tree formation message. One possible aggregation tree for given network graph in Figure 5.1 is shown in Figure 5.2. To initiate the query dissemination phase, the base station broadcasts the query request message with the query nonce N in the aggregation tree. The query request message contains new query nonce N for each query. The fresh nonce is used for each new query to prevent replay attacks in the network.

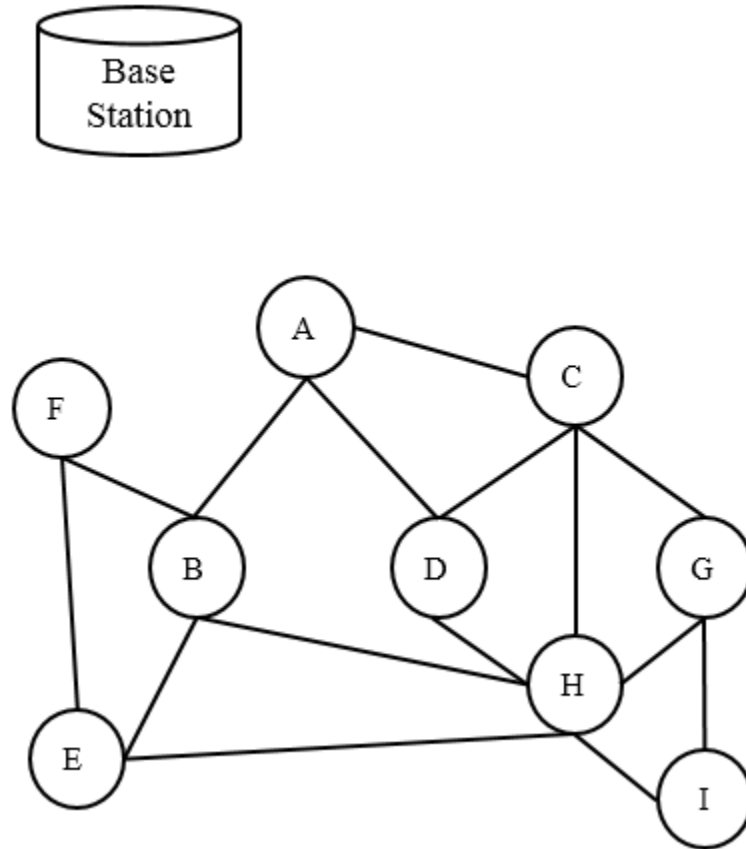

Fig. 5.1.: Network graph

5.5 Aggregate Commit

The aggregate commit phase constructs logical commitment tree to the data values and to the intermediate aggregated data-values on top of the aggregation tree. These logical commitment trees are then propagated to the base station by the root node in an aggregation tree. The base station then broadcasts the logical commitment trees in the aggregation tree using an authenticated broadcast. Using these commitment values the rest of the network can verify that their respective data values have been incorporated into the final aggregate value. The commitment tree is a logical tree built on top of an aggregation tree.

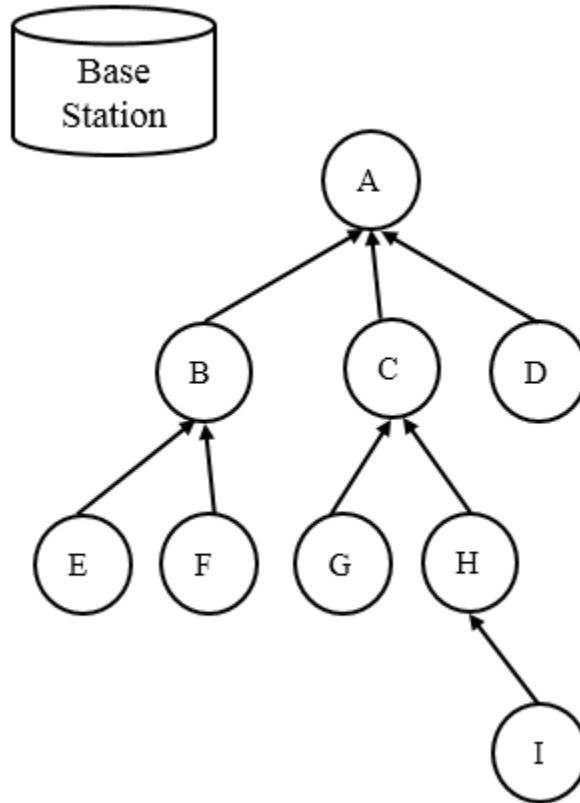

Fig. 5.2.: Simplified Aggregation tree for network graph in Figure 5.1

Definition 5.5.1 [33] *A commitment tree is a tree where each vertex has an associated label representing the data that is passed on to its parent. The labels have the following format:*

$$\langle \text{count}, \text{value}, \text{complement}, \text{commitment} \rangle$$

where *count* is the number of leaf vertices in the subtree rooted at this vertex; *value* is the SUM aggregate computed over all the leaves in the subtree; *complement* is the aggregate over the COMPLEMENT of the data values; and *commitment* is a cryptographic commitment.

For example, the sensor node A creates the label for the leaf vertex A_0 as follows :

$$A_0 = \langle A_{\text{count}}, A_{\text{value}}, \overline{A_{\text{value}}}, A_{\text{commitment}} \rangle$$

where A_{value} is the sensor data collected by A , $\overline{A_{\text{value}}} = r - A_{\text{value}}$ with r being the upper bound on legal data values in the accepted range. The values of $A_{\text{count}} = 1$,

and $A_{commitment} = A_{id}$ which is unique ID of A as A_0 is the leaf vertex of A . Internal vertices in the commitment tree represent aggregation operations, and have labels that are defined based on their children. Suppose an internal node I has child vertices with the following labels : A_1, A_2, \dots, A_q , where $A_i = \langle A_{icount}, A_{ivalue}, \overline{A_{ivalue}}, A_{icommitment} \rangle$. The label for the internal vertex I_j is given as follows:

$$\begin{aligned}
 I_j &= \langle I_{jcount}, I_{jvalue}, \overline{I_{jvalue}}, I_{jcommitment} \rangle \\
 I_{jcount} &= \sum A_{icount} \\
 I_{jvalue} &= \sum A_{ivalue} \\
 \overline{I_{jvalue}} &= \sum \overline{A_{ivalue}} \\
 I_{jcommitment} &= H[N || I_{jcount} || I_{jvalue} || \overline{I_{jvalue}} || A_1 || A_2 || \dots || A_q]
 \end{aligned}$$

The word vertex is used for the node in the commitment tree and the node is used for the node in the aggregation tree. There is a mapping between the node in the aggregation tree and the vertices in the commitment tree. A vertex is a logical element in the commitment tree where as the node is a physical sensor node which does all the local computations and wireless communications. The commitment field in the label is calculated using collision resistant hash function which makes impossible for an adversary to change the commitment structure once it is sent to the base station.

5.5.1 Aggregate Commit: Naive Approach

In the naive approach, during aggregation process each sensor node calculates the cryptographic hash of all its inputs which includes its own data value. The aggregation result along with the hash value called a label, is then passed on to the parent in the aggregation tree. The commitment tree for the aggregation tree of Figure 5.2 is shown in Figure 5.3 .

In this example, the node B receives E_0 from E , F_0 from F and has its own leaf vertex B_0 . The node B aggregates all three vertices by creating a new vertex B_1 and sends B_1 to its parent node A . The label of an internal vertex B_1 is defined as follows:

$$B_1 = \langle 3, B_{1value}, \overline{B_{1value}}, H[N || 3 || B_{1value} || \overline{B_{1value}} || B_0 || E_0 || F_0] \rangle .$$

All the intermediate nodes receives labels from their children and aggregates them including its own data item. The labels of all the intermediate vertices on the path of the leaf node to the root node for the commitment tree are given as follows:

$$\begin{aligned}
I_0 &= \langle 1, I_{value}, \overline{I_{value}}, I_{id} \rangle \\
H_1 &= \langle 2, H_{1value}, \overline{H_{1value}}, H[N||2||H_{1value}||\overline{H_{1value}}||H_0||I_0] \rangle; \\
H_{1value} &= I_{value} + H_{value} \\
B_1 &= \langle 3, B_{1value}, \overline{B_{1value}}, H[N||3||B_{1value}||\overline{B_{1value}}||B_0||E_0||F_0] \rangle; \\
B_{1value} &= B_{value} + E_{value} + F_{value} \\
C_1 &= \langle 4, C_{1value}, \overline{C_{1value}}, H[N||4||C_{1value}||\overline{C_{1value}}||C_0||G_0||H_1] \rangle; \\
C_{1value} &= C_{value} + G_{value} + H_{1value} \\
A_1 &= \langle 9, A_{1value}, \overline{A_{1value}}, H[N||9||A_{1value}||\overline{A_{1value}}||A_0||D_0||B_1||C_1] \rangle; \\
A_{1value} &= A_{value} + D_{value} + B_{1value} + C_{1value}.
\end{aligned}$$

In the naive approach the information rate is $1/n$ where n is the number of children for the given node. As each node aggregates all the labels into one label before sending it to the parent node.

5.5.2 Aggregate Commit: SHIA's Approach

The aggregation tree is a subset of the network graph so it can be unbalanced meaning not having uniform distribution of nodes. This approach tries to isolate the the commitment tree from the aggregation tree by making a commitment tree protocol independent of the input network tree. This approach constructs the commitment tree which are complete binary trees. In the naive approach, each sensor node always computes the aggregate sum of all its inputs which is a greedy approach. SHIA uses delayed aggregation approach, which performs an aggregation operation if and only if it results in a balanced binary commitment tree.

SHIA's elaborates aggregation algorithm for producing balanced commitment trees is as follows [33]: " In the naive commitment tree, each sensor node passes to its parent a single message containing the label of the root vertex of its commit-

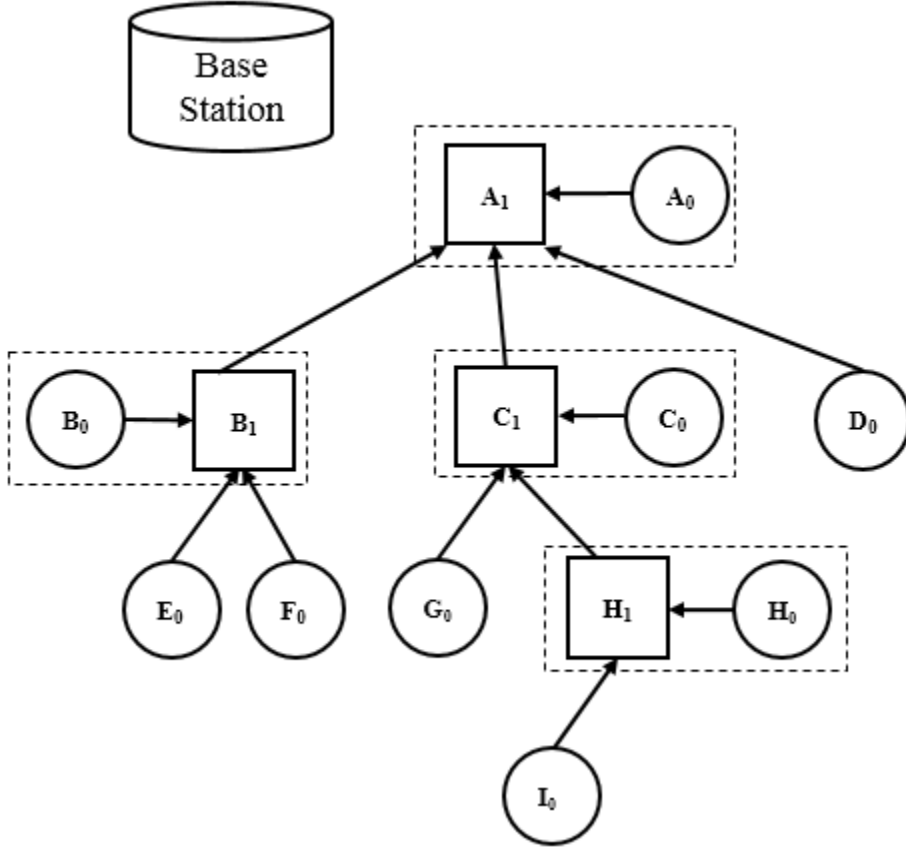

Fig. 5.3.: Naive commitment tree for Figure 5.2.

ment subtree T_s . In the delayed aggregation algorithm, each sensor node passes on the labels of the root vertices of a set of commitment subtrees $F = \{T_1, \dots, T_q\}$. We call this set a commitment forest, and we enforce the condition that the trees in the forest must be complete binary trees, and no two trees have the same height. These constraints are enforced by continually combining equal-height trees into complete binary trees of greater height.

Definition 5.5.2 [33] *A commitment forest is a set of complete binary commitment trees such that there is at most one commitment tree of any given height.*

The commitment forest is built as follows. Leaf nodes in the aggregation tree originate a single-vertex commitment forest, which they then communicate to their parent nodes. Each internal node I originates a similar single-vertex commitment forest. In

addition, I also receives commitment forests from each of its children. The node I keeps track of which root vertices were received from which of its children. It then combines all the forests to form a new forest as follows. Suppose I wishes to combine q commitment forests F_1, \dots, F_q . Note that since all commitment trees are complete binary trees, tree heights can be determined by inspecting the count field of the root vertex. We let the intermediate result be $F = F_1 \cup \dots \cup F_q$, and repeat the following until no two trees are the same height in F . Let h be the smallest height such that more than one tree in F has height h . Find two commitment trees T_1 and T_2 of height h in F , and merge them into a tree of height $h + 1$ by creating a new vertex that is the parent of both the roots of T_1 and T_2 according to the inductive rule in Definition 5.5.1”.

The following example illustrates the commitment tree generation process for the node A of Figure 5.2.

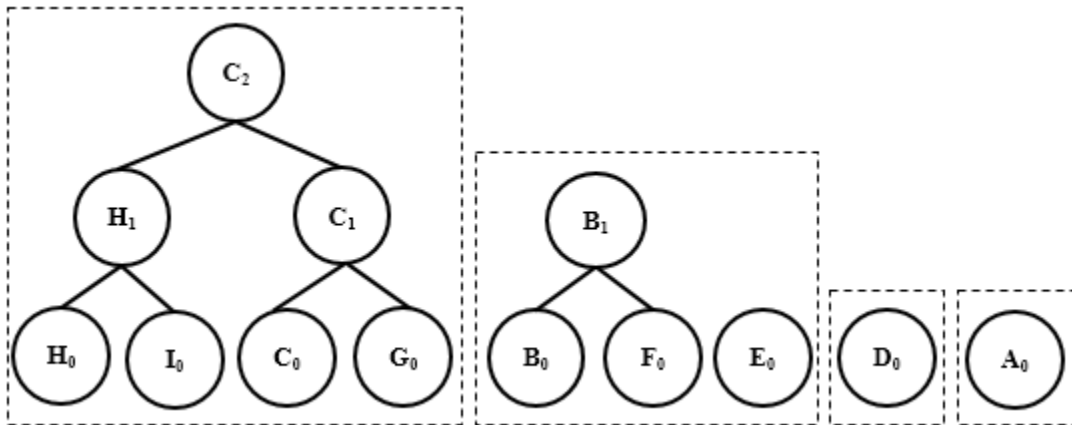

Fig. 5.4.: A receives C_2 from C , (B_1, B_0) from B , D_0 from D and generates A_0 . The received commitment forests are indicated by dashed-line box.

$$A_0 = \langle 1, A_{value}, \overline{A_{value}}, A_{id} \rangle$$

$$D_0 = \langle 1, D_{value}, \overline{D_{value}}, D_{id} \rangle$$

$$E_0 = \langle 1, E_{value}, \overline{E_{value}}, E_{id} \rangle$$

$$B_1 = \langle 2, B_{1value}, \overline{B_{1value}}, H(N||2||B_{1value}||\overline{B_{1value}}||B_0||F_0) \rangle$$

$$C_2 = \langle 4, C_{2value}, \overline{C_{2value}}, H(N||4||C_{2value}||\overline{C_{2value}}||H_1||C_1) \rangle$$

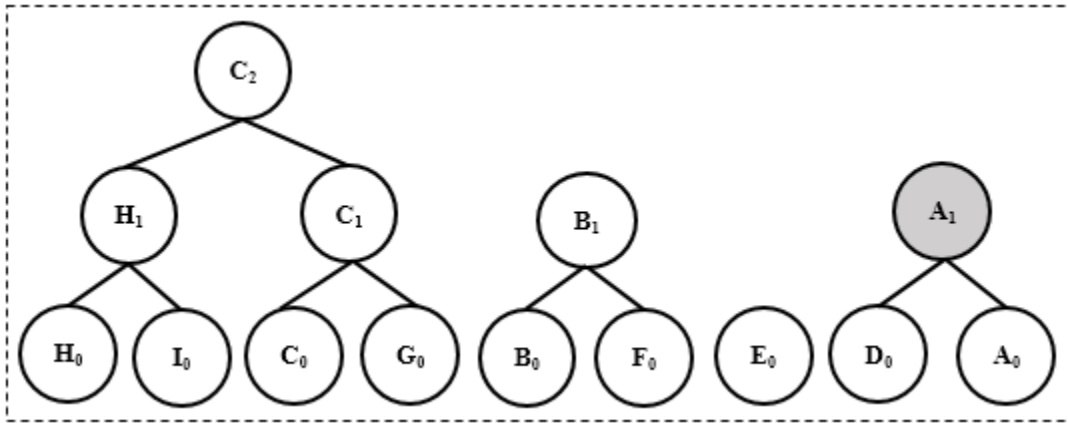

Fig. 5.5.: First Merge: A_1 vertex created by A.

$$A_1 = \langle 2, A_{1value}, \overline{A_{1value}}, H(N||2||A_{1value}||\overline{A_{1value}}||A_0||D_0) \rangle;$$

$$A_{1value} = A_{value} + D_{value}; \quad \overline{A_{1value}} = \overline{A_{value}} + \overline{D_{value}}.$$

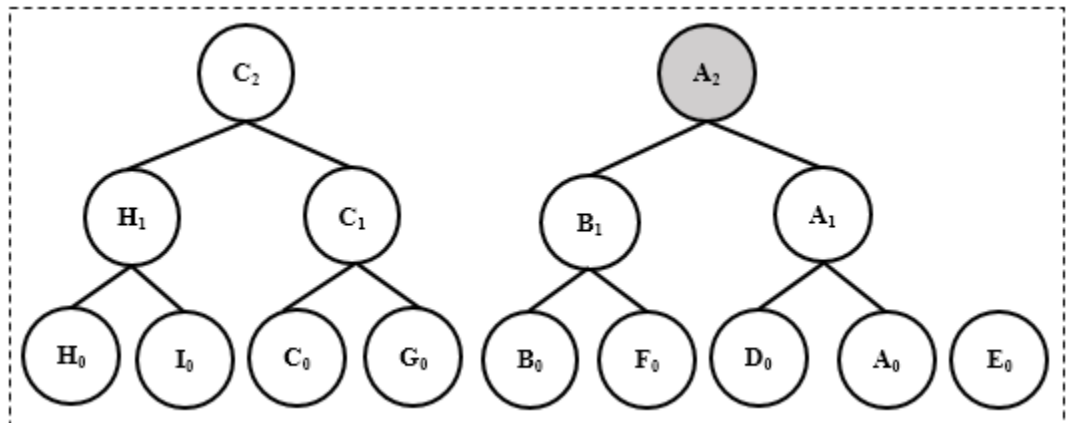

Fig. 5.6.: Second Merge: A_2 vertex created by A.

$$A_2 = \langle 4, A_{2value}, \overline{A_{2value}}, H(N||4||A_{2value}||\overline{A_{2value}}||B_1||A_1) \rangle;$$

$$A_{2value} = A_{1value} + B_{1value}; \quad \overline{A_{2value}} = \overline{A_{1value}} + \overline{B_{1value}}.$$

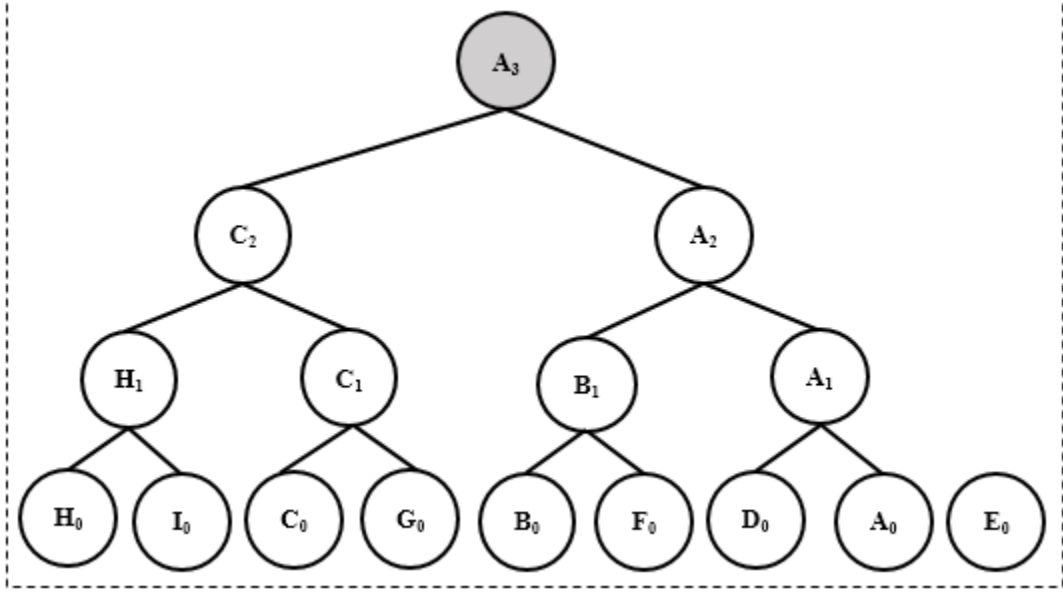

Fig. 5.7.: Third Merge: A_3 vertex created by A.

$$A_3 = \langle 8, A_{3value}, \overline{A_{3value}}, H(N||8||A_{3value}||\overline{A_{3value}}||C_2||A_2) \rangle;$$

$$A_{3value} = A_{2value} + C_{2value}; \quad \overline{A_{3value}} = \overline{A_{2value}} + \overline{C_{2value}}$$

Once the base station has received the all the logical commitment trees also known as the final commitment forest from the root node, it verifies that none of the SUM or COMPLEMENT are negative. If any of those are negative then the base station does not accept the aggregated result and alerts the network notifying that it has detected tampering of data values. If both the fields are positive then the base station then proceeds further, and verifies that $SUM + COMPLEMENT = nr$ where r is the largest allowed legal data value for each node. On successful verification, the base station then begin the next phase of result checking.

5.6 Result Checking

SHIA presents novel distributed verification algorithm, achieving provably optimal security while maintaining sublinear edge congestion. In our work, we take similar approach and add new capabilities to help find an adversary. SHIA's result checking phase is given as follows : "The purpose of the result checking phase is to enable each sensor node I to independently verify that its data value (I_{value}) was added into the SUM aggregate, and the complement $\overline{I_{value}}$ of its data value was added into the COMPLEMENT aggregate. First, the base station sends the aggregation results from the aggregation commit phase to every sensor node in the network using authenticated broadcast. Each sensor node then individually verifies that its contributions to the respective SUM and COMPLEMENT aggregates were indeed counted. If so, it sends an authentication code to the base station. The authentication code is also aggregated for communication efficiency. When the base station has received all the authentication codes, it is then able to verify that all sensor nodes have checked that their contribution to the aggregate has been correctly counted." The result checking process has the following phases.

Distributing Final Commitment Values In this phase, the base station sends each of the received commitment labels to the entire network using authenticated broadcast. Authenticated broadcast means that each sensor node can verify that the message was sent by the base station and no one else.

Distributing Off-path Values Each vertex must receive all of its off-path values to do the verification. The off-path values are defined as follows.

Definition 5.6.1 [33] *The set of off-path vertices for a vertex u in a tree is the set of all the siblings of each of the vertices on the path from u to the root of the tree that u is in (the path is inclusive of u).*

Vertex receives its off-path values from its parent. Each internal vertex has two children. For example, an internal vertex k has two children k_1, k_2 . k transmits

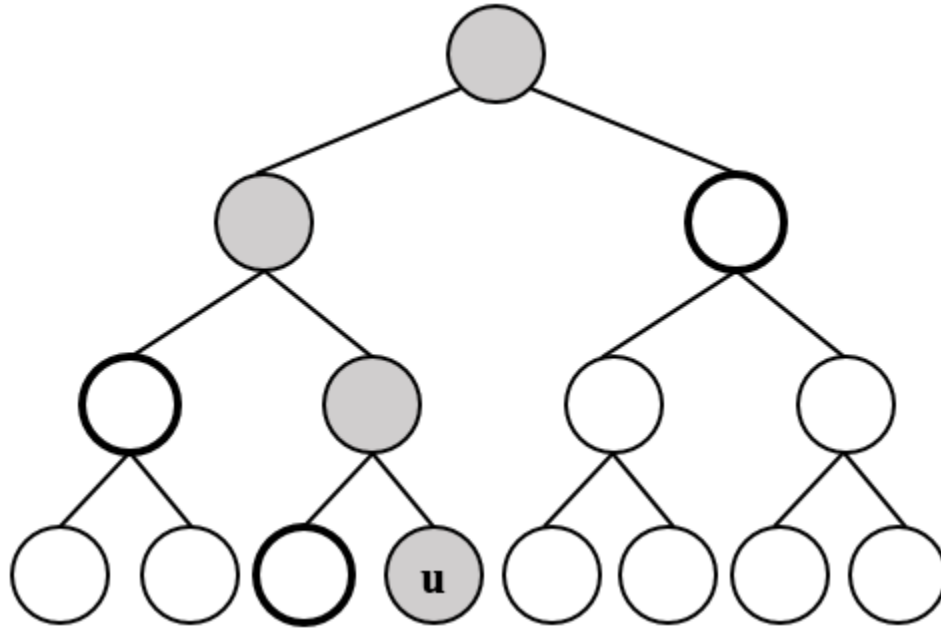

Fig. 5.8.: Off-path values of node u are highlighted with bold outline.

the label of k_1 to k_2 and vice versa. k tags the relevant information of its left and right child. Once a vertex receives all of its off-path values it begins the verification phase.

Verification of Contribution In this phase, the leaf vertex calculates the root vertex's label using its own label and off-path vertex labels received from its parent. It compares the the calculated root vertex's label with the label received from the base station. If those two labels match then it proceeds to the next step with Acknowledgment (ACK) message or with Negative Acknowledgment (NACK) message. This allows the leaf to verify that its label was not modified on the path to the root during the aggregation commit phase.

Collection of Authentication Codes Once each sensor node verifies its contribution to the root label it proceeds further to transmit the relevant message authentication code to its parent in the aggregation tree. The message authentication codes (MAC) for sensor node A with ACK and NACK are given as

follows : $MAC_{sk_A}(N||ACK), MAC_{sk_A}(N||NACK)$ where ACK and NACK unique message identifier for positive and negative acknowledgment respectively, MAC is the message authentication algorithm, N is the query nonce and sk_A is secret key that node A shares with the base station. Collection of authentication code starts with the leaf nodes in the aggregation tree. The leaf nodes in the aggregation tree transmit their authentication codes to their parent. Once the parent node has received the authentication from all of its children it does XOR operation on all the authentication codes including its own authentication code and sends it to its parent in the aggregation tree hierarchy. Each internal node in the aggregation tree repeats the process. Finally, the root of an aggregation tree sends a single authentication code to the base station which is an XOR of all the authentication codes of the aggregation tree.

Verification of confirmations Since the base station shares the secret key of all the nodes in the network, it computes the following:

$$\bigoplus_{i=1}^n MAC_{sk_i}(N||ACK)$$

Then it compares the computed code with the received code. If those two codes match, then the base station accepts the aggregation result.

Hence, SHIA achieves security over the Truncated SUM which is a resilient aggregator according to Wagner [32]. Our protocol enhances SHIA to achieve desired security over the SUM which is non-resilient aggregate.

6. SYSTEM DESIGN

Here we elaborate the rationale behind the design specifications of our secure aggregation protocol for sensor networks, the mechanism used to achieve it and implementation details.

6.1 Introduction

The most significant design aspect of the sensor network is the *longevity of the sensor network*. A sensor network tends to have limited life span as they are powered by the battery. The lifetime of the sensor network is inversely proportional to the sensor nodes' power consumption. One of the most dominating factor for the power consumption is transmitting and receiving data between sensor nodes, making network bandwidth an expensive resource. The bandwidth is a more expensive resource than the local data computation, as trans-receiving activity consumes more power than computation. The obvious solution to increase the lifespan of the sensor network is to decrease the bandwidth usage in the network. As we know, data aggregation techniques can greatly reduce the bandwidth usage in the network, increasing the lifespan of the network. Hence, data-aggregation techniques are one of the key tool in our tool box while designing protocol for the sensor networks.

The second most significant factor in the design of the data aggregation protocol is *Security Architecture*. The International Telecommunications Union (ITU) Telecommunication Standardization Sector (ITU-T) Recommendation X.800, *Security Architect for Open Systems Interconnection* (OSI) provides a systematic approach for it. The OSI security architecture describes the security attacks, mechanism and services defined as follows:

Security attack is any action that compromises the security of information owned by an organization or entity [40].

Security service is a service that enhances the security of the data processing systems and the information transfers of an organization. The services are intended to counter security attacks, by using one or more security mechanisms [40].

Security mechanism is a mechanism that is designed to detect, prevent, or recover from a security attack [40].

Security attacks can be classified as *active attacks* and *passive attacks*. Active attacks modifies the data stream. It can be subdivided into four categories: *replay*, *masquerade*, *modification of messages*, and *denial of service*. Replay attacks sniffs network and capture the data unit. Then it uses the captured data in future retransmission sessions to access secret resources in an unauthorized manner. A masquerade occurs when a malicious party pretends to be a legitimate party and access the secret resources. For example, authentication sequence can be captured by hijacking the session and replaying the information in all the future sessions. Modification of message means that some portion of a legitimate message is changed. For example, a message stating “Only Barack Obama is authorized to read classified documents nuclear deal.” is modified to say “Only Michelle Obama is authorized to read classified documents nuclear deal.” The denial of service blocks the normal access of communication resources. Active attacks are hard to prevent completely because to do so requires physical protection of all entities at all times. Passive attacks tries to learn information from the network but does not affect the network resources. Such attacks are eavesdropping and monitoring of network traffic. Passive attacks are difficult to detect as they do not change the message. It is plausible to prevent these attacks by means of symmetric and asymmetric key encryption. Passive attacks are subtler and outside the scope of our thesis.

Security services are divided into six categories: *Authentication*, *Access Control*, *Data Confidentiality*, *Data Integrity*, *Non-repudiation*, *Availability*. Authentication

service assures that a authenticity to the communication services. It assures the origin of the data unit. It does not protect the data unit against the modification of data units. This type of service secures electronic mail where there are no prior communications between two end hosts. Data Confidentiality ensures the protection of transmitted data from passive attacks. It is also known as secrecy or privacy. For example, classifieds mission of United States Armed Forces are highly confidential. Ensuring confidentiality can be difficult. For example, how do we determine who is authorized to access the secret information? Can authorized party reveal that information to family, friends or other parties? [41] Data Integrity assures that the only authorized entities can modify the information; where modification means writing, creating, deleting and changing the information. A database entries of a patient's allergy information must be accurate. The doctor should be able to trust that the information and cure the patient. If a integrity of a system is compromised then the service may report the issue. There are alternatives which allows to recover automatically from the loss of integrity. Availability means that the information of a system being accessible and usable by an authorized parties according to performance specification at appropriate times. It applies to the information and services. It addresses the concern raised by the denial of service attacks. Non repudiation service requires neither the sender nor the receiver can deny the transmission. This security service is necessary in electronic commerce applications, where a consumer must not be able to deny the authorization of a purchase and the merchant must not be able to deny the received payments. Access Control is the mechanism to control the permissions to various resources via communications links. Login credentials and locks are two analogues mechanism of access control.

Security mechanisms follows this principle of Open Design.

Definition 6.1.1 [22] *The principle of open design states that the security of a mechanism should not depend on the secrecy of its design or implementation.*

Designers and implementers of a program must not depend on secrecy of the details of their design and implementation to ensure security. The term “security through

obscurity” captures this concept exactly. The following security mechanisms may be included into the relevant networking layer to provide some of the security services. *Encryption* is the use of mathematical algorithms to encrypt the message to hide it from unauthorized users. *Digital Signature* appends the data to a cryptographic transformation of data which provides the security services like authentication, non-repudiation and confidentiality. *Hash functions* provides maps any size input to fixed size out put and provides irreversible encryption. *Traffic Padding, Routing Control, Notarization, Authentication Exchange* are possible mechanisms as well but they are outside the scope of our thesis.

As you can see, expectations from secure networking protocol are far-reaching. It is very ambitious for any system to have all the above mentioned security services at the same time. If we have to achieve all the security services for sensor networks we can make each sensor node signs its reading data and then send data with its signature to its parent. The network forwards all the data with their respective signatures to the base station. The base station verifies all the signatures and then calculates the aggregate function. Clearly, this approach is not practical as it requires n signatures to traverse through the link between the base station and the root node of the network; where n is the number of nodes in the network. Which makes that link the bottleneck link of the network. And if that link breaks we loose the entire network connectivity.

In reality all the security services are not always required. For example, Protecting banner advertisements on web pages. The provider of the advertisements do not care if they copy the advertisements and show it to other people. So, there is no confidentiality at all. But they want to prevent people from changing the advertisements to the different types of advertisements. Also, when a client downloads a file from the file server using Internet, he can verify the integrity of the file using the checksum. But it is okay if somebody on the network sniffed the downloading activity as far as it did not change the content of the file. In this application, a client requires the integrity of the file but the privacy of the client, the file server and the

Internet service provider are not required. To give an analogy with a physical world application, when a person writes a postcard, he puts his own signature on the it. When that postcard delivers successfully by the postal service, the receiving party can verify the integrity of the message from the handwriting and the signature of the person. The postal service knows the sender and the receiver of the postcard. It can even read the postcard. Again, the integrity is important not the confidentiality. In most engineering discipline, it is useful to clarify the requirements carefully before embarking on a project [2]. An important aspect to the computer security, as discussed by Anderson [42], that is often ignored: designed the security before careful thought of the needs. It is crucial to find out which security services are desired for the particular application, so we can use the relevant security mechanisms to provide those services.

The most significant aspect data aggregation schemes is *Integrity*. Suppose, the sensor network is deployed to measure the certain harmful chemical levels in the lab atmosphere and raise an alarm if the it increases above certain level. If the base station fails to raise an alarm because of the false aggregated data, can create catastrophic and lethal situation. Hence, data integrity is an essential security service.

Data integrity can be achieved with the error detection and error correction techniques. The first step towards achieving the data integrity in the sensor network is to *detect any malicious activity* in the network. The second step is the ability to *locate the malicious node or an adversary* in the network. We think detecting a malicious activity without tracing down the malicious node responsible for it, is of no value. To give an analogy with the physical world, it is like you know there is a crime in the city and you do not do anything about it. Locating the criminals responsible for the crime is mandatory to abolish the crime in the city. In similar way, locating the malicious node and removing it from the network is an important security service. Failing to provide such a security service, allows an adversary to continue doing the malicious activity in the future, which makes aggregated sensor data garbage. The network has to redo the all the work to create a response for the query from the base

station, which consumes lots of bandwidth. An adversary can repeat this process until the network dies due to low battery power, creating a denial of service attack in the network. Hence, detecting a malicious node who is responsible for the malicious activity is equally important. If we can track down the malicious node in the network then we can remove that node from the network for all future queries. And make sure that all the future queries are not manipulated by any malicious node in the network. Hence, the fourth and fifth most significant design aspects of secure aggregation protocol are *detect the malicious activity* (in terms of data aggregation) and can *detect the adversary* in the network, respectively.

To detect an adversary (or prove someone guilty), we need proof that the adversary is responsible for the malicious activity. Consider the following example showing the analogy with the signature scheme in the physical world, used by the postal services. When a postman delivers the package, the receiving party has to sign the document informing that he verified and received the package. Since only the receiving party can create his signature, in the future he can not claim of not receiving the package or receiving the damaged or incorrect package. If he claims such, the postal company has the signed document as the proof mentioning that the package was received successfully, by the receiving party. The signed document also ensures to the postal company that the postman did not misplace or steal the package. The signature scheme used by the postal service promises non repudiation security service. Hence, we require *non-repudiation* security service in the sensor network.

6.2 System Design Specifications

We want to design a secure aggregation protocol which maximizes the *network lifetime*. The protocol can be applied to *any hierarchical sensor network*. Further, we want protocol to work on *resilient* and *non-resilient* aggregate functions without compromising any desired security properties. In addition, We want protocol to be secure with *a single* or *multiple adversaries* in the network. Moreover, we want the

protocol to protect against any *active attacks*. If the aggregation result is accepted by the base station it should have very high confidence in the result, meaning that we want the highest level of *data integrity* security service in the protocol. We need the capabilities to *detect any malicious activity*. If there is any malicious activity in the network, we should be able to *locate an adversary* responsible for it, in the network. Also, we want the *non-repudiation* security service so neither sender nor receiver can deny the transmission or receiving of the message, which is mandatory to locate an adversary. Finally, we want to achieve this with the least amount of *bandwidth and computation* overhead in the network. So, the protocol can be easily implemented in the real world sensor networks. It is not that difficult to provide mentioned security properties to protect against active attacks in the sensor network. We will show that it requires sub-linear edge congestion to provide these services.

To detect any malicious activity in the network which is an important part of achieving data-integrity in the network we use *Hash Functions* as security mechanism. To protect against any active security attacks, provide authentication and non-repudiation security services we use *Digital Signatures* as the security mechanisms. Both of these mechanisms are described in detail in Chapter 3.

7. DATA AGGREGATION WITH INTERNAL VERIFICATION

The concept of an aggregate commit with verification scheme is that all the sensor nodes in the network send the signature of the message along with the message. They send their certificates if the parent node does not have it already. The parent node verifies all the received signatures from its children and proceeds with the aggregation process. After aggregation, the parent node can throw away all the signatures from its children and signs the message of its children or it can pass its children's signatures to its parent. The pros and cons of each approach are discussed in the following sections. Once the base station receives the aggregated value it starts the verification process. If there is no malicious activity in the network then it accepts the result and takes an action. If the malicious activity is detected during the verification phase then the base station starts interacting with the nodes in the network and detects an adversary using interactive proof.

7.1 Data-Item

We describe structure of the data-item and its signature, used in creating the commitment tree for the aggregate commit with verification approach. The differences between the data-item and the label structure of SHIA, with rationale behind it are discussed.

Definition 7.1.1 *A commitment tree is a binary tree where each vertex has an associated data-item representing the data that is passed on to its parent. The data-items have the following format:*

$$\langle id, count, value, commitment \rangle$$

Where *id* is the unique ID of the node; *count* is the number of leaf vertices in the

subtree rooted at this vertex; value is the SUM aggregate computed over all the leaves in the subtree and commitment is a cryptographic commitment.

Each sensor node creates its own data-item during commitment tree generation process which is called the leaf vertex of the node. For example, sensor node A creates its data-item A_0 as follows:

$$A_0 = \langle A_{id}, 1, A_{value}, H(N||1||A_{value}) \rangle . \quad (7.1)$$

where A_{id}, A_{value} is the unique ID and sensor reading of the node A . The count is 1 as there is only vertex in the subtree rooted at A , H is the collision resistant hash function, and N is the query nonce.

The first difference between SHIA's label structure and our data-item structure is that we remove the *complement* field from the label structure see Definition 5.5.1. The complement field is redundant information in the label. The complement field is used by the base station (the querier in SHIA), before the result checking phase. It is used to verify $SUM + COMPLEMENT = n \cdot r$ where n is the number of nodes in the network, r is the upper bound on the allowed sensor readings. We can achieve the same upper bound without the complement field. As the querier knows n, r and it gets SUM from the root of the aggregation tree. If $SUM > n \cdot r$, then the base station knows some node or nodes in the network reported out of range readings.

Another difference between SHIA's label and our data-item structure is that we include unique ID of the node in its data-item. SHIA does not have the ID field in their label structure as they do not do internal verification while creating a commitment tree and while distributing off-path values. Also, in the label format ID of the node is hashed in the commitment field after the first aggregation and virtually gets lost. Hence, SHIA can not provide security services such as authenticity, non-repudiation and is vulnerable to all sorts of active attacks. We do internal verification while creating the commitment tree and distributing off-path values. So, it is necessary for any aggregate node to know the ID of all the received data-items in its forest, for the verification of the received signatures as shown in the following sections.

7.1.1 Signing and Verification of the Data-Item

Each sensor node sends the signature of its data-item signed by itself using its own secret key. For example, the signature of A_0 of the Equation 7.1 is given as follows:

$$S = \text{Sign}_{\text{sk}_A}(A_0) \quad (7.2)$$

where sk_A is the secret key of the sensor node A , Sign is the signing algorithm. The parent node receives the data-item and its signature from its child. It also receives the certificate from its child which is shown in Table 7.1. From the digital certificate

Table 7.1.: Digital Certificate

Unique ID of the sensor node
Public key of the sensor node
Certification Authority's name
Certification Authority's digital signature

the parent node receives the public-key of its child, which is used to decipher the signature. For example, the parent node of B verifies $\text{Sign}_{\text{sk}_A}(A_0)$ as follows:

$$\text{Verify}_{\text{pk}_A}(A_0, S) = \begin{cases} \text{true} & \text{with probability of 1} & \text{if } S = \text{Sign}_{\text{sk}_A}(A_0) \\ \text{false} & \text{with overwhelming probability} & \text{if } S \neq \text{Sign}_{\text{sk}_A}(A_0) \end{cases} \quad (7.3)$$

where pk_A is the public key of A , Verify is the verification algorithm. In this protocol, the certification authority is the base station.

7.1.2 Security Benefits

While creating the commitment tree, the sensor S sends the data-item S_0 , and its signature S to its parent in the aggregation tree. The signature allows the parent node to verify the *authenticity* of the sensor node. As only sensor node S can create the signature using its secret key. The signature S assures the *integrity* of the data-item

S_0 . Because either the data-item or the signature has been tampered in any way the verification algorithm returns false. It allows the sender to have the proof for the sent data-item and the receiver to have the proof for the received data-item. Hence, providing the security service of *non-repudiation*. The digital signature depends on the message so the parent node can not reuse the signature for other messages in the future. Hence, protecting the network against the *replay attacks*. Hence, it protects against the *active attacks*.

7.2 Commitment Payload

We define commitment payload based on the commitment forest see Definition 5.5.2. We also define transmit payload as follows.

Definition 7.2.1 *A **commitment payload** is a set of data-items of the root vertices of the trees with their respective signatures in the outgoing commitment forest and an additional signature for the transmission.*

Definition 7.2.2 *The **transmit payload** is the concatenation of all the data-items in the commitment payload.*

For brevity, we use the term forest instead of the commitment forest and payload instead of the commitment payload. Consider, the aggregation tree shown in Figure 7.1, where B is the parent of A , C is the parent of B and D is the parent of C . While creating the commitment tree A creates its data-item A_0 according to Equation 7.1. A sends only one data-item to B therefore A 's payload (A_{pay}), transmit-payload (A_τ) are given as follows:

$$A_{pay} = \langle A_0, \text{Sign}_{sk_A}(A_0), \text{Sign}_{sk_A}(A_\tau) \rangle \text{ where } A_\tau = \langle A_0 \rangle \quad (7.4)$$

The sensor node C 's payload is shown in Figure 7.2. The commitment tree generation process is described in the later sections. The sensor node C sends two data-items to D therefore C 's payload (C_{pay}), transmit-payload (C_τ) are given as follows:

$$C_{pay} = \langle C_0, \text{Sign}_{sk_C}(C_0), B_1, \text{Sign}_{sk_C}(B_1), \text{Sign}_{sk_C}(C_\tau) \rangle \text{ where } C_\tau = \langle B_1 \parallel C_0 \rangle$$

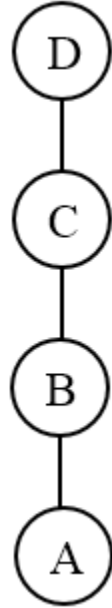

Fig. 7.1.: Palm Shaped Aggregation Tree

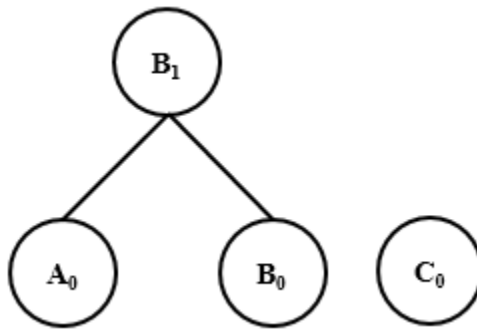

Fig. 7.2.: Commitment Payload of Sensor Node C

The verification of the received signatures in the payload is done by the parent node in the same way described in Section 7.1.1.

7.2.1 Security Benefits

As described in Section 7.1.2, the signature of the transmit-payload $\text{Sign}_{S_S}(S_\tau)$ assures the integrity and authentication of the transmit-payload S_τ . In addition to

that, the signature of the transmit-payload is like the signature for the transmission. To the sender, it assures that it is sending only the data-items included in the signature of the transmit-payload. Further, it establish that none of the data-items gets added or remove from the transmit-payload during the transmission. To the receiver, it assures that it receives all the data-items included in the signature of the transmit-payload and none of the data-items were stranded or added additionally to the payload of its child. For example, the signature on the C 's transmit-payload $\text{Sign}_{sk_C}(C_\tau)$ assures that the sensor node C sent only two data-items C_0, B_1 in its payload. It also establishes that none of the data-items in its payload have been left stranded. As we said, it's like the signature for the transmission.

7.3 Key Differences

In SHIA, all the leaf nodes in the aggregation tree send only their respective data-items to the parent in the aggregation tree. In our approach, all the leaf nodes send the data-item, the signature of the data-item and the signature of the transmit-payload to their parent node in the aggregation tree. The child node sends its certificate as well if the parent node does not have it in its memory already.

In SHIA, the parent node proceeds with the aggregation process without verifying the received data-items. In our protocol, the parent node verifies the received signature using the the verification algorithm. It proceeds with the aggregation only if all the signatures are verified true.

In SHIA, the trusted base station verifies the final received data-items. And upon detecting the malicious activity in the network, the base station raises an alarm. The base station does not do anything to detect malicious node responsible for the malicious activity. In our approach, upon detecting the malicious activity the base station interacts with several relevant nodes in the network to trace down the malicious node. Also, the base station issues the certificate to the sensor nodes in the network.

7.3.1 Bandwidth

According to Definition 7.1.1, the typical size of the data-item packet is 400 bits as shown below. If one uses Elliptic Curve Digital Signature Algorithm (ECDSA)

Table 7.2.: Data-Item Size

ID	COUNT	VALUE	COMMITMENT
20 bits	21 bits	20 bits	256 bits

then the size of signature is 500 bits [43]. And the certificate size is 1500 bits. So, at max we have to send additional 2000 bits with the data-item ¹. We think it is worthwhile to send these additional bits because of all the security benefits we gain from it.

7.4 Two Ways of Forwarding Payload

As described in the previous sections, we send the data-items with their signature along with the signature of the transmit-payload while creating the commitment tree. Here, we describe two different approaches to send the signatures in the aggregation tree hierarchy based on the two different ways of signing the data-items. To demonstrate two approaches we use the aggregation tree shown in Figure 7.1 and the payload of the sensor node C shown in Figure 7.2. In both the approaches, the sensor node C sends all the data-items in its payload with their respective signatures to its parent sensor node D along with the signature of its transmit-payload C_τ .

In the first approach, C verifies $\text{Sign}_{\text{sk}_B}(B_1)$ and sends it to D without any modifications as follows:

$$\begin{aligned}
 C_{\text{pay}} &= \langle C_0, \text{Sign}_{\text{sk}_C}(C_0), B_1, \text{Sign}_{\text{sk}_B}(B_1), \text{Sign}_{\text{sk}_C}(C_\tau) \rangle \text{ where } C_\tau = \langle C_0 || B_1 \rangle \\
 C_0 &= \langle C_{id}, 1, C_{value}, H(N || 1 || C_{value}) \rangle \\
 B_1 &= \langle B_{id}, 2, B_{1value}, H(N || 2 || B_{1value} || A_0 || B_0) \rangle; B_{1value} = B_{value} + A_{value}
 \end{aligned} \tag{7.5}$$

¹The packets size are close approximate to the actual packet size. The actual packet size may differ based on the implementation.

The sensor node C sends three signatures $\text{Sign}_{\text{sk}_B}(B_1)$, $\text{Sign}_{\text{sk}_C}(C_0)$ and $\text{Sign}_{\text{sk}_C}(C_\tau)$ to its parent D . It requires the parent node D to know the public key of the sensor nodes C and B , hence two certificates.

In the second approach, the sensor node C can verify the $\text{Sign}_{\text{sk}_B}(B_1)$ then remove the old signature and creates new signature $\text{Sign}_{\text{sk}_C}(B_1)$ and sends to D as follows:

$$C_{\text{pay}} = \langle C_0, \text{Sign}_{\text{sk}_C}(C_0), B_1, \text{Sign}_{\text{sk}_C}(B_1), \text{Sign}_{\text{sk}_C}(C_\tau) \rangle \text{ where } C_\tau = \langle C_0 || B_1 \rangle \quad (7.6)$$

The sensor node C sends three signatures $\text{Sign}_{\text{sk}_C}(B_1)$, $\text{Sign}_{\text{sk}_C}(C_0)$ and $\text{Sign}_{\text{sk}_C}(C_\tau)$ to its parent D . But all the signatures are signed by the sensor node C , it requires the parent node D to know the public key of only the sensor node C , hence D need to know only one certificate.

To give an analogy with a real world application, consider the following example. Suppose, one want to buy a diamond from the local diamond retailer. Some Diamonds are expensive commodity, so the end customer wants to verify its authenticity and integrity before purchasing. Now, suppose the diamond was created by the manufacturer in Africa, it was sold to a national wholesaler in the United States. The national wholesaler sells it to the state level reseller and he sells it to the city or county level retailer from whom the customer purchases the diamond as shown below.



Fig. 7.3.: Diamond Supply Chain.

One approach to verify the authenticity of the commodity is to make each entity in the supply chain to verify all the signatures on the received entity and sign on top of it. And then forward the commodity with all the signatures to the next entity in the supply chain. The next entity repeats the same procedure. Hence, any entity in the supply chain need to verify the signatures of all its descendants in the supply chain. In our example, it means to make the manufacturer from Africa signs the diamond

and sells the signed diamond and sends the certificate to the national level wholesaler in United States. The national level wholesaler in United States verifies the signature from the manufacturer using manufacturer's certificate. Then he adds his signature and certificate, and sells the diamond signed with two signatures and two certificates to the state level reseller. The state level reseller verifies both the signatures on the diamond using the respective certificates. Then they add their signature and send their certificate, and sells the diamond signed with three signatures and three certificates to the city level retailer. The city level retailer does the same thing before selling the diamond to the end customer. In the end, the customer needs to verify all four signatures, using the respective certificates.

An alternative approach to verify the authenticity of the commodity is to make each entity in the supply chain verify the signature, throw away the old signature, and then add its own signature on it. It means the next entity in the supply chain need to verify only a single signature. The next entity repeats the same procedure. Hence, any entity in the supply chain need to verify the signature of only its direct peer in the supply chain. In our example, it means to make the manufacturer from Africa signs the diamond and sells the signed diamond with his certificate to the national level wholesaler in United States. The national level wholesaler in United States verifies the signature from the manufacturer using the manufacturer's certificate. Then he removes the signature of the manufacturer, adds his own signature and certificate, and sells the diamond signed with one signature and one certificate to the state level reseller. The state level reseller verifies only the signature from the wholesaler using the wholesaler's certificate. Then they remove the signature of the wholesaler, adds their own signature and certificate, and sells the diamond signed with one signature and one certificate to the city level retailer. The city level retailer does the same thing before selling the diamond to the end customer. In the end, the customer needs to verify only one signature of the city level retailer using retailer's certificate. This approach requires very few number of certificates overall in the supply chain.

We call these two approaches Forwarding signatures without resigning the data-items (FSwoRD), Forwarding signatures with resigning the data-items (FSwRD) as shown in Equations 7.5 and 7.6 respectively. Both the approaches have their pros and cons and the perfect approach depends heavily on the application. The various aspects of both the approaches for sensor nodes are discussed in the following sections.

8. OUR PROTOCOL

In this chapter, we describe our protocol with FSwRD approach beginning from query dissemination phase till the detecting an adversary. Our protocol using FSwRD can also be applied using FSwoRD with the obvious modifications. We briefly describe the differences along the way.

8.1 Query Dissemination

The protocol begins with the base station initiating the query request to the sensor network. The base station does the authenticated broadcast of its query to the entire sensor network asking the network to report the aggregated result of the sensor reading values. It includes the query nonce in its query to avoid replay attacks in the future. We use the same hash chain process to generate unique query nonce for the base station as described in Section 5.4. Once the sensor nodes receive the query from the base station they constructs their own leaf vertex by creating the data-items of their sensor readings and its signature. The sensor nodes constructs their payloads and send it to their parent in the aggregation tree. The details of the commitment tree generation is described in the next section.

8.2 Commitment Tree Generation

For the given aggregation tree the commitment forest is built as follows. The commitment tree generation begins from the sensor nodes with the highest depth (leaf nodes) in the aggregation tree. Leaf sensor nodes in the aggregation tree constructs their leaf vertices by creating data-items, signatures of those data-items and signature of the transmit-payload according to Equations 7.1, 7.2, 7.4, respectively. Then they

send the payload to their parents in the aggregation tree. Each internal sensor node in the aggregation tree also constructs their leaf vertex. In addition, internal sensor node receives the payload from each of its children, which impacts its forest. For each child, internal node first verifies the signature of the transmit-payload and then the signature of the data-item for one child at a time. Once internal node verifies all the received signatures, it merges all the data-items with same count value from its forest. It merges two data-items by creating a new data-item with count value incremented by one and whose value is the addition of value field of the previous two data-items. Note that we can easily determine the height of the commitment tree from the count value. Suppose, after verifying all the signatures from the payloads, an internal sensor node I has to merge i data-items D_1, D_2, \dots, D_i in its forest. Let c be the smallest count value in I 's forest. The sensor node I finds two data-items D_1 and D_2 from its forest with the same count value c and merges them into a new data-item with the count of $c + 1$ as shown in Figure 8.1. It repeats the process until no two data-items in its forest have the same count value. The data-item of the A_2 is given as follows:

$$A_2 = \langle A_{id}, 4, A_{2value}, H(N||4||A_{2value}||B_1||D_1) \rangle; A_{2value} = B_{1value} + D_{1value}.$$

We demonstrate the commitment tree generation process for the aggregation tree shown in Figure 8.2. In this example, A has three children. A receives one payload from each of its children, which impacts A 's forest. After verifying all the signatures from each child's payload, A uses the data-items in its forest to constructs its payload, which is sent to the base station. We describe the payload generation process for sensor nodes B, C, D and A in order.

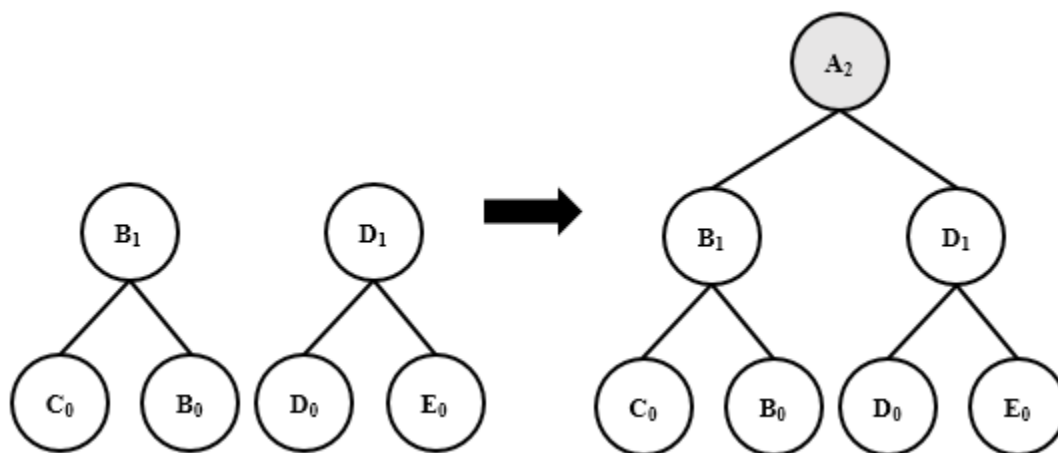

Fig. 8.1.: Input node A has B_1 and C_1 in its forest. It aggregates these two trees and constructs A_2 .

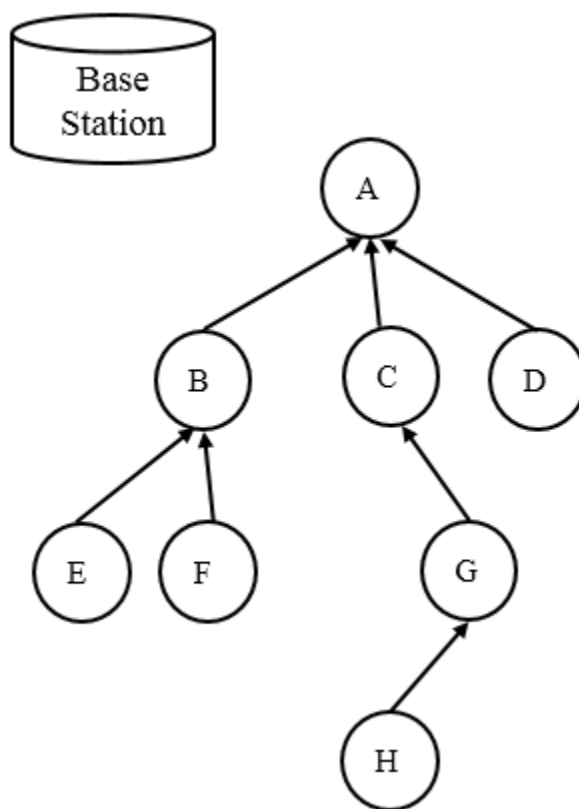

Fig. 8.2.: Aggregation Tree.

The sensor node B constructs its payload from its forest. Its forest consists of payloads received from E and F . The leaf sensor nodes E and F constructs their payloads according to Equation 7.4 as follows:

$$\begin{aligned}
 E_{pay} &= \langle E_0, \text{Sign}_{sk_E}(E_0), \text{Sign}_{sk_E}(E_\tau) \rangle \text{ where } E_\tau = \langle E_0 \rangle \\
 E_0 &= \langle E_{id}, 1, E_{value}, H(N||1||E_{value}) \rangle \\
 F_{pay} &= \langle F_0, \text{Sign}_{sk_F}(F_0), \text{Sign}_{sk_F}(F_\tau) \rangle \text{ where } F_\tau = \langle F_0 \rangle \\
 F_0 &= \langle F_{id}, 1, F_{value}, H(N||1||F_{value}) \rangle .
 \end{aligned}$$

B receives E_{pay} and F_{pay} from E and F respectively. B verifies all the signatures in the received payloads. Then it constructs its own data-item B_0 . Now, B has B_0, E_0, F_0 in its forest as shown in Figure 8.3. As all the data-items have the same count value, B has an option while selecting two data-items to merge. B aggregates E_0, F_0 and constructs B_1 . After creating B_1 none of the data-items have the same count value. So, B constructs its payload B_{pay} and sends it to A as follows:

$$\begin{aligned}
 B_{pay} &= \langle B_0, \text{Sign}_{sk_B}(B_0), B_1, \text{Sign}_{sk_B}(B_1), \text{Sign}_{sk_B}(B_\tau) \rangle \text{ where } B_\tau = \langle B_0||B_1 \rangle \\
 B_1 &= \langle B_{id}, 2, B_{1value}, H(N||2||B_{1value}||E_0||F_0) \rangle; B_{1value} = E_{value} + F_{value} \\
 B_0 &= \langle B_{id}, 1, B_{value}, H(N||1||B_{value}) \rangle .
 \end{aligned}$$

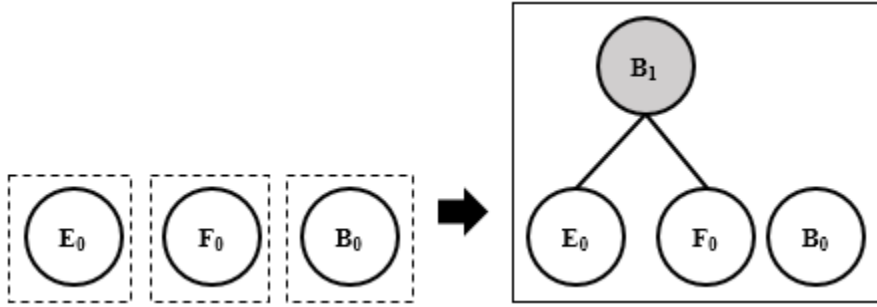

Fig. 8.3.: Transformation from B 's forest to its payload. Each dashed-line box shows forest and solid-line box shows payload of the respective sensor node.

In similar way, the sensor node C in the aggregation tree receives G_{pay} from G which is defined as follows:

$$G_{pay} = \langle G_1, \text{Sign}_{sk_G}(G_1), \text{Sign}_{sk_G}(G_\tau) \rangle \text{ where } G_\tau = \langle G_0 || H_0 \rangle$$

$$G_1 = \langle G_{id}, 2, G_{1value}, H(N || 2 || G_{1value} || G_0 || H_0) \rangle; G_{1value} = G_{value} + H_{value}$$

$$G_0 = \langle G_{id}, 1, G_{value}, H(N || 1 || G_{value}) \rangle$$

$$H_0 = \langle H_{id}, 1, H_{value}, H(N || 1 || H_{value}) \rangle .$$

C verifies all the signatures in the received payload G_{pay} and constructs C_0 . Now, C has C_0, G_1 in its forest as shown in Figure 8.4. As none of the data-items have the same count value, C does not merge those two data-items. But C removes the old signature on G_1 and signs G_1 with its secret key. So, C constructs its payload C_{pay} and sends it to A as follows:

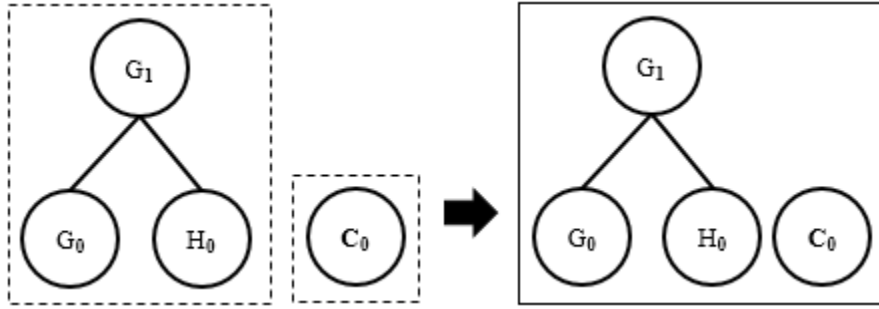

Fig. 8.4.: C 's forest aggregation creating its payload.

$$C_{pay} = \langle C_0, \text{Sign}_{sk_C}(C_0), G_1, \text{Sign}_{sk_C}(G_1), \text{Sign}_{sk_C}(C_\tau) \rangle \text{ where } C_\tau = \langle C_0 || G_1 \rangle$$

$$C_0 = \langle C_{id}, 1, C_{value}, H(N || 1 || C_{value}) \rangle .$$

The sensor node D constructs its payload D_{pay} and sends it to A as follows:

$$D_{pay} = \langle D_0, \text{Sign}_{sk_D}(D_0), \text{Sign}_{sk_D}(D_\tau) \rangle; \text{ where } D_\tau = \langle D_0 \rangle$$

$$D_0 = \langle D_{id}, 1, D_{value}, H(N || 1 || D_{value}) \rangle .$$

The root node of the aggregation tree A receives the payloads B_{pay} , C_{pay} and D_{pay} from B , C and D respectively. A verifies all the signatures in the received payloads and constructs A_0 . Now, A has G_1, C_0, B_1, B_0, D_0 and A_0 in its forest as shown

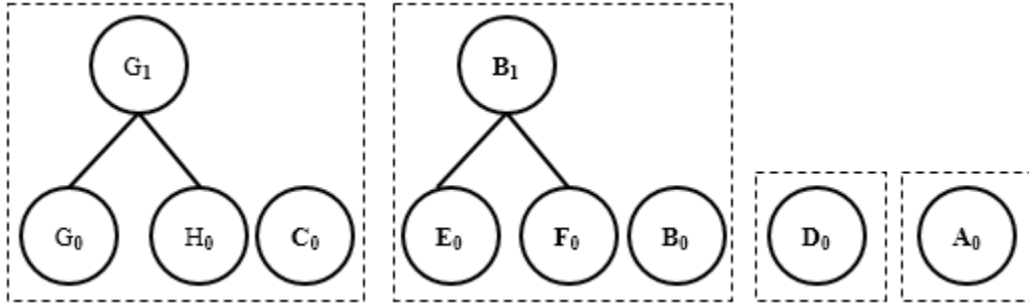

Fig. 8.5.: A 's forest: A receives three payloads from C, B, D and constructs A_0

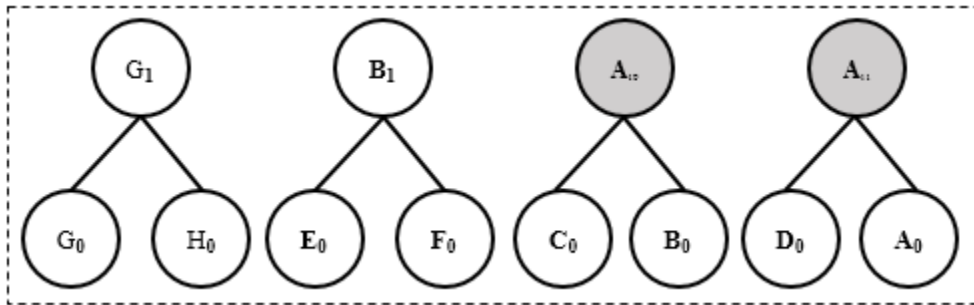

Fig. 8.6.: A 's forest: after first merge

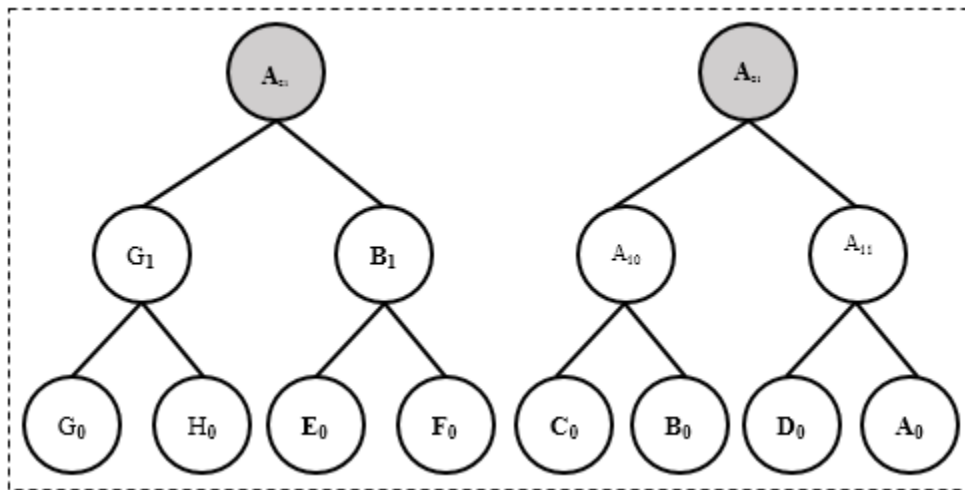

Fig. 8.7.: A 's forest: after second merge

in Figure 8.5. A has four data-items with count value of 1. In the first merge, A aggregates those data-items and constructs A_{10} and A_{11} as shown in Figure 8.6. Now, A has four data-items with count value of 2. In the second merge, A aggregates those data-items and constructs A_{20} and A_{21} as shown in Figure 8.7. Finally, A has two data-items with count value of 4. In the final merge, A aggregates those data-items and constructs A_3 as shown in Figure 8.8. Then A constructs payload and sends it to the base station as follows:

$$\begin{aligned}
 A_{pay} &= \langle A_3, \text{Sign}_{sk_A}(A_3), \text{Sign}_{sk_A}(A_\tau) \rangle \text{ where } A_\tau = \langle A_3 \rangle \\
 A_3 &= \langle A_{id}, 8, A_{3value}, H(N||8||A_{3value}||A_{20}||A_{21}) \rangle; A_{3value} = A_{20value} + A_{21value} \\
 A_{20} &= \langle A_{id}, 4, A_{20value}, H(N||4||A_{20value}||G_1||B_1) \rangle; A_{20value} = G_{1value} + B_{1value} \\
 A_{21} &= \langle A_{id}, 4, A_{21value}, H(N||4||A_{21value}||A_{10}||A_{11}) \rangle; A_{21value} = A_{10value} + A_{11value} \\
 A_{10} &= \langle A_{id}, 2, A_{10value}, H(N||2||A_{10value}||B_0||C_0) \rangle; A_{10value} = B_{value} + C_{value} \\
 A_{11} &= \langle A_{id}, 2, A_{11value}, H(N||2||A_{11value}||D_0||A_0) \rangle; A_{11value} = D_{value} + A_{value} \\
 A_0 &= \langle A_{id}, 1, A_{value}, H(N||1||A_{value}) \rangle .
 \end{aligned}$$

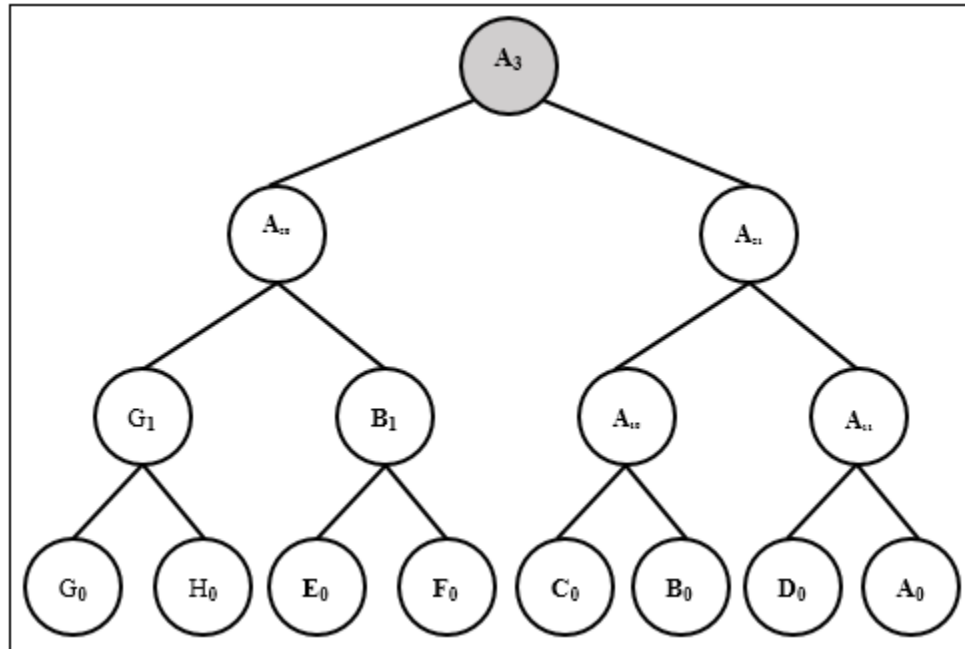

Fig. 8.8.: A 's payload : A sends this to the base station.

Once the base station receives the payload from the root of the aggregation tree, it verifies all the signatures in the payload. In the previous example, the base station receives A_{pay} from the sensor node A . It verifies the signatures $\text{Sign}_{sk_A}(A_3)$, $\text{Sign}_{sk_A}(A_\tau)$ in the received payload. If the base station verifies all the signatures to true it initiates the result checking phase.

8.3 Result Checking

The purpose of the *result checking* phase is to require that all the sensor nodes verify their individual contributions to the final aggregate value. If there is any inconsistency in the aggregation process then with the help of the base station, trace down the node responsible for causing the inconsistency in the aggregation process.

8.3.1 Dissemination of Final Payload by the Base Station

Once the base station receives the payloads of the root node of the aggregation tree, it verifies all the signatures in the payload and then sends each of the data-items in the payload to the entire sensor network using authenticated broadcast. The authenticated broadcast allows the sensor nodes to verify that the data-items are sent by the base station. The authentication ensures no one else is masquerading the base station. In our previous example, the base station receives only one data-item A_3 in the payload sent by A . In that case, the base station's payload B_{pay} which is sent to the entire network is given as follows:

$$B_{pay} = \langle A_3, \text{Sign}_{sk_B}(A_3), \text{Sign}_{sk_B}(B_\tau) \rangle \text{ where } B_\tau = \langle A_3 \rangle .$$

8.3.2 Dissemination of Off-Path Values

To enable verification each sensor node must receive all of its off-path values. The off-path values of the sensor nodes can be determined according to the Definition

5.6.1. Each internal vertex I in the commitment tree has two children u_1 and u_2 . To disseminate off-path values, I sends the data-item of u_1 to u_2 , and vice-versa (I also attaches relevant information tagging u_1 as the right child and u_2 as the left child) along with the signatures of the data-item and the signature of the transmit-payload. In our previous example, internal vertex A_{10} , shown in Figure 8.8, has two children C_0 and B_0 . A_{10} (which is sensor node A in aggregation tree) sends the following off-path values to C and B respectively as follows:

$$\begin{aligned} & \langle B_0, \text{Sign}_{\text{sk}_A}(B_0), \text{Sign}_{\text{sk}_A}(A_\tau) \rangle \text{ where } A_\tau = \langle B_0 \rangle \\ & \langle C_0, \text{Sign}_{\text{sk}_A}(C_0), \text{Sign}_{\text{sk}_A}(A_\tau) \rangle \text{ where } A_\tau = \langle C_0 \rangle . \end{aligned}$$

An internal vertex I receives data-items with their respective signatures from its parent. It verifies the signatures of the received data-items then resigns them and sends those data-items (and left/right tags) with their signatures to both of its children. Continuing the previous example, internal vertex A_{10} receives A_{11} and A_{20} from its parent A_{21} . A_{10} sends the following off-path values to C and B respectively as follows:

$$\begin{aligned} & \langle B_0, \text{Sign}_{\text{sk}_A}(B_0), A_{11}, \text{Sign}_{\text{sk}_A}(A_{11}), A_{20}, \text{Sign}_{\text{sk}_A}(A_{20}), \text{Sign}_{\text{sk}_A}(A_\tau) \rangle \\ & \text{where } A_\tau = \langle B_0 || A_{11} || A_{20} \rangle \\ & \langle C_0, \text{Sign}_{\text{sk}_A}(C_0), A_{11}, \text{Sign}_{\text{sk}_A}(A_{11}), A_{20}, \text{Sign}_{\text{sk}_A}(A_{20}), \text{Sign}_{\text{sk}_A}(A_\tau) \rangle \\ & \text{where } A_\tau = \langle C_0 || A_{11} || A_{20} \rangle . \end{aligned}$$

In FSwRD, all the leaf vertices need to know only one certificate as they receive data-items signed by their parent vertex. In FSwoRD, all the leaf vertices might need to know $\log l$ certificates, where l is the number of leaf-vertices in commitment tree including the leaf vertex. Continuing the previous example, C and B receive three signatures from A_{10} . All these three signatures are signed by A . Hence, C and B need to know the certificate of A . Whereas in FSwoRD, C and B receives three signatures from A . From those three two will be signed by A and one will be signed by either B or C depending on the data-item. Therefore, B need to know the certificates of A and C , and C need to know the certificates of A and B .

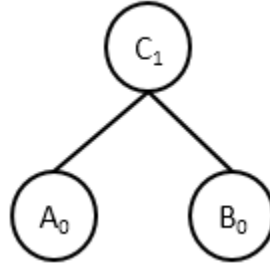

Fig. 8.9.: One Possible Commitment Tree

We show the significance of the commitment field while distributing the off-path values. The commitment field helps us detecting any *malicious activity* in the network. Because of the signatures infrastructure eventually we can detect an adversary. For example, if an internal vertex simply forwards incorrect data-item to its children then the relevant leaf vertex will complain, as the leaf vertex will not be able to derive the data-item received using authenticated broadcast from the base station. Because of the signatures internal vertex responsible for forwarding the incorrect data-item will be caught. Another scenario could be that an internal vertex changed the its children's data-item while creating commitment tree and sending the incorrect off-path values to compensate discrepancy. To illustrate the scenario consider the following Example.

Example 8.3.1 *Suppose the vertices in the commitment tree of Figure 8.9 have the data-items defined as follows. Note that we did not include the signatures of these data-items in this example for simplification.*

$$\begin{aligned}
 A_0 &= \langle A_{id}, 1, 10, H(N||1||10) \rangle \\
 B_0 &= \langle B_{id}, 1, 20, H(N||1||20) \rangle \\
 C_1 &= \langle C_{id}, 2, 30, H(N||2||30||A_0||B_0) \rangle
 \end{aligned}$$

Now suppose C changes A_0 and B_0 to A'_0 and B'_0 by changing the value fields and then applies aggregate commit algorithm. C can send either C'_1 or C''_1 to the base station. But it will be caught by base station in both cases. To compensate for

the discrepancy, C constructs B'_0 and A'_0 off-path values trying to hide its malicious activity from the base station.

$$A'_0 = \langle A_{id}, 1, 100, H(N||1||10) \rangle$$

$$B'_0 = \langle B_{id}, 1, 200, H(N||1||20) \rangle$$

$$C'_1 = \langle C_{id}, 2, 300, H(N||2||300||\mathbf{A}_0''||\mathbf{B}_0) \rangle \text{ or}$$

$$C''_1 = \langle C_{id}, 2, 300, H(N||2||300||\mathbf{A}_0||\mathbf{B}_0'') \rangle$$

$$B''_0 = \langle B_{id}, 1, 290, H(N||1||20) \rangle$$

$$A''_0 = \langle A_{id}, 1, 280, H(N||1||10) \rangle$$

During the dissemination of the root data-item phase, A and B using authenticated broadcast receives either C'_1 or C''_1 from the base station based on what C has sent to base station. During the dissemination of off-path values phase, A and B receives B''_0 and A''_0 from C respectively. During the verification of inclusion phase, A and B derives the root data-item using the received off-path values, and it does not match with the received root data-item as follows:

$$A \text{ uses } (A_0, B''_0) \text{ and derives } \langle 2, 300, H(N||2||300||\mathbf{A}_0||\mathbf{B}_0'') \rangle = C''_1 \neq C'_1$$

$$B \text{ uses } (A''_0, B_0) \text{ and derives } \langle 2, 300, H(N||2||300||\mathbf{A}_0''||\mathbf{B}_0) \rangle = C'_1 \neq C''_1.$$

Hence, during the collection of authentication codes phase, either A or B sends its authentication codes with NACK message.

Above example shows how the commitment field in the data-item provides data-integrity to the protocol. It makes it nearly impossible for an adversary to tamper with the data-items while creating commitment tree and/or while distributing off-path values. This malicious activity can be detected by the commitment filed in the data-item. Later, we show that the adversary can be detected with the provided signature infrastructure. Once a vertex has received all the off-path vertices, it can proceed to the verification step.

8.3.3 Verification of Inclusion

Once the sensor node has received all the data-items of its off-path vertices from its parent, first it verifies the signature of all the received data-items and then it verifies that no aggregation result tampering has occurred on the path between its leaf vertex and the root of its commitment tree. It also verifies that its sensor reading was aggregated correctly by all the intermediate aggregate nodes. For each vertex on the path from the root of its commitment tree, it derives the data-items according to Definition 5.5.1. It is able to do so since the off-path values provide all the necessary information to perform the data-item computation. In the previous example, C receives B_0, A_{11} and A_{20} from its parent node and it has C_0 . It aggregates $\langle C_0, B_0 \rangle$ and derives A_{10} . Then it aggregates $\langle A_{10}, A_{11} \rangle$ and derives A_{21} . Finally it aggregates $\langle A_{21}, A_{20} \rangle$ and derives A_3 . Then it compares the derived A_3 with the A_3 received from the base station. Based on those data-items are identical or not the node proceeds with the next step accordingly. If those data-items are identical then the node sends the authentication code with ACK message and if those data-items are not identical then the node sends the authentication code with NACK message.

8.3.4 Collection of Authentication codes

The authentication codes for sensor node I , with their positive and negative acknowledgment message, are defined as follows:

$$\begin{aligned} \text{Positive} &: \text{MAC}_{\text{sk}_I}(\text{N}||\text{ACK}) \\ \text{Negative} &: \text{MAC}_{\text{sk}_I}(\text{N}||\text{NACK}). \end{aligned} \tag{8.1}$$

sk_I is the secret key of the sensor node I , ACK and NACK are special messages for positive and negative acknowledgment respectively. The authentication code with ACK message is sent by the sensor node if it verifies its contribution correctly to the root commitment value during the *verification of inclusion* phase and vice versa. Leaf sensor nodes in the aggregation tree first send their authentication codes to their parents in the aggregation tree. Once an internal sensor node has received authen-

tication codes from all its children, it computes the XOR of its own authentication code with all the received codes, and forwards it to its parent. For example, the sensor node B shown in Figure 8.2, receives the authentication codes $\text{MAC}_{\text{sk}_E}(\text{N}||\text{ACK})$, $\text{MAC}_{\text{sk}_F}(\text{N}||\text{ACK})$ from E, F respectively, and it has its own authentication code with ACK message then B sends the following authentication code to A .

$$\text{MAC}_{\text{sk}_E}(\text{N}||\text{ACK}) \oplus \text{MAC}_{\text{sk}_F}(\text{N}||\text{ACK}) \oplus \text{MAC}_{\text{sk}_B}(\text{N}||\text{ACK})$$

Because of the XOR function we do not have to forward all the authentication codes. At the end of the process, the base station receives a single authentication code Δ_{root} from the root of an aggregation tree.

8.3.5 Verification of Authentication Codes

To verify that every sensor node has sent its authentication code with ACK, the base station computes the Δ_{ack} as follows:

$$\Delta_{ack} = \bigoplus_{i=1}^n \text{MAC}_{\text{sk}_i}(\text{N}||\text{ACK}) \quad (8.2)$$

Here, the addition represents an XOR operation. The base station can compute Δ_{ack} as it knows the secret key sk_i for each sensor node i . Then it compares the computed Δ_{ack} with the received root authentication code Δ_{root} . If those two codes match then it accepts the aggregated value or else it proceeds further to find an adversary.

To detect an adversary, the base station needs to identify which nodes in the aggregation tree sent their authentication codes with NACK during the verification of inclusion phase. The node who sent authentication code with NACK during the verification of inclusion phase is called a complainer. We claim that if there is a single complainer in the aggregation tree during the verification of inclusion phase then the base station can find the complainer in **linear time**. To find a complainer, the base station computes the complainer code c as follows:

$$c := \Delta_{root} \oplus \Delta_{ack} \quad (8.3)$$

Then it computes the complainer code c_i for all node $i = 1, 2, \dots, n$.

$$c_i := \text{MAC}_{\text{sk}_i}(N||\text{ACK}) \oplus \text{MAC}_{\text{sk}_i}(N||\text{NACK}) \quad (8.4)$$

After that, it compares c with all c_i one at a time. The matching code indicates the complainer node. The base station needs to do $C_{(n,1)}^1$ calculations according to Equation 8.4 and same number of comparisons to find a complainer in the aggregation tree. Hence, the base station can find a single complainer in linear time.

Example 8.3.2 *If there are four nodes s_1, s_2, s_3, s_4 in an aggregation tree and their authentication codes with ACK, NACK message in the binary format are defined as follows:*

$$\begin{aligned} \text{MAC}_{\text{sk}_1}(N||\text{ACK}) &= (1001)_2; \text{MAC}_{\text{sk}_1}(N||\text{NACK}) = (1101)_2 \\ \text{MAC}_{\text{sk}_2}(N||\text{ACK}) &= (0110)_2; \text{MAC}_{\text{sk}_2}(N||\text{NACK}) = (1111)_2 \\ \text{MAC}_{\text{sk}_3}(N||\text{ACK}) &= (0101)_2; \text{MAC}_{\text{sk}_3}(N||\text{NACK}) = (0111)_2 \\ \text{MAC}_{\text{sk}_4}(N||\text{ACK}) &= (0011)_2; \text{MAC}_{\text{sk}_4}(N||\text{NACK}) = (1110)_2. \end{aligned}$$

Suppose the root of an aggregation tree computed the $\Delta_{\text{root}} = (0100)_2$ as described in Subsection 8.3.4. The base station calculates $\Delta_{\text{ack}} = (1001)_2$ according to the Equation 8.2. Then it calculates the complainer code $c = (1101)_2$ according to the Equation 8.3. The base station also computes the complainer codes for each sensor node according to the Equation 8.4 as follows:

$$c_1 = (0100)_2, c_2 = (1001)_2, c_3 = (0010)_2, c_4 = (1101)_2.$$

The base station compares complainer code c with individual complainer code c_i and finds that $c = c_4$. So, the base station identifies that the s_4 complained, during verification of inclusion phase.

The following binary illustration helps visualize that applying XOR is negating the contribution of the authentication code with NACK. The base station receives the

$${}^1C_{(n,1)} = \binom{n}{1} = n$$

following from the root an aggregation tree, which includes one authentication code with NACK.

$$\begin{array}{cccc}
 1 & 0 & 0 & 1 \\
 0 & 1 & 1 & 0 \\
 0 & 1 & 0 & 1 \\
 1 & 1 & 1 & 0 \\
 \hline
 0 & 1 & 0 & 0 \\
 \underbrace{\hspace{4cm}} & & & \\
 & \Delta_{root} & &
 \end{array}$$

The base station calculates Δ_{ack} , Δ_{nack} and complainer code c as follows:

$$\begin{array}{cccc}
 1 & 0 & 0 & 1 & 1 & 1 & 0 & 1 \\
 0 & 1 & 1 & 0 & 1 & 1 & 1 & 1 \\
 0 & 1 & 0 & 1 & 0 & 1 & 1 & 1 \\
 + & 0 & 0 & 1 & 1 & 1 & 1 & 0 \\
 \hline
 1 & 0 & 0 & 1 & 1 & 0 & 1 & 1 \\
 \underbrace{\hspace{4cm}} & & \underbrace{\hspace{4cm}} & & & & & \\
 & \Delta_{ack} & & \Delta_{nack} & & & &
 \end{array}$$

$$\begin{array}{cccc}
 1 & 0 & 0 & 1 \\
 0 & 1 & 0 & 0 \\
 \hline
 1 & 1 & 0 & 1 \\
 \underbrace{\hspace{4cm}} & & & \\
 & c & &
 \end{array}$$

Then the base station calculates the complainer code for each node i as follows:

$$\begin{array}{cccc}
 1 & 0 & 0 & 1 & 0 & 1 & 1 & 0 & 0 & 1 & 0 & 1 & 0 & 0 & 1 & 1 \\
 1 & 1 & 0 & 1 & 1 & 1 & 1 & 1 & 0 & 1 & 1 & 1 & 1 & 1 & 1 & 0 \\
 \hline
 0 & 1 & 0 & 0 & 1 & 0 & 0 & 1 & 0 & 1 & 1 & 0 & 1 & 1 & 0 & 1 \\
 \underbrace{\hspace{4cm}} & & \underbrace{\hspace{4cm}} & & \underbrace{\hspace{4cm}} & & \underbrace{\hspace{4cm}} & & \underbrace{\hspace{4cm}} & & & & & & & \\
 & c_1 & & c_2 & & c_3 & & c_4 & & & & & & & &
 \end{array}$$

Finally, concludes that node 4 is complaining.

In general, to find k complainers the base station needs to do $C_{(n,k)}^2$ calculations and the same number of comparisons to find k complainers. Suppose, there are more than one complainer in the network then the base station uses the following recursive algorithm to find all the complainers in the network.

Algorithm 1 Finding complainer tree in a given forest

- 1: BS requests authentication codes of all the tree roots in the aggregation tree root's forest.
 - 2: BS simulates authentication codes of all the tree roots in the aggregation tree root's forest with ACK message.
 - 3: BS compares the requested and simulated authentication codes.
 - 4: BS constructs $T = \{T_1, T_2, \dots, T_{\lg n}\}$ whose authentication codes do not match.
 - 5: **for all** $t \in T$ **do**
 - 6: Call Algorithm 2 with (t)
-

Algorithm 2 Finding complainer node in a given tree

- 1: BS requests the authentication codes of child C_1 and C_2 for the given tree.
 - 2: BS simulates the authentication codes of child C_1 and C_2 with ACK message.
 - 3: BS compares the requested and simulated authentication codes and identifies C' whose authentication codes do not match.
 - 4: **if** C' is a leaf vertex **then**
 - 5: Add C' to complainer vertex set C
 - 6: **else**
 - 7: Call Algorithm 2 with (C')
-

Note the fact that, in Algorithm 2, one of the child nodes will not match with the simulated authentication codes of the base station. These algorithms are recursive and runs in exponentially time. This algorithm detects complainers faster if there are more complainers in the same commitment tree. Hence, we expect this algorithm to run in linear time.

$${}^2C_{(n,k)} = \binom{n}{k} = n!/(k! \cdot (n-k)!)$$

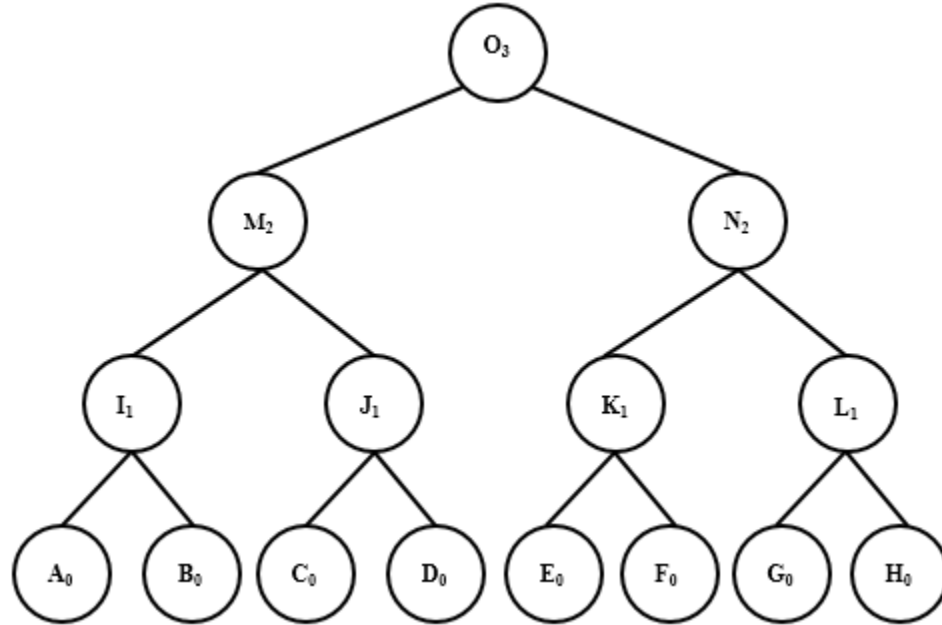

Fig. 8.10.: A Commitment Tree With All Unique Vertices

8.3.6 Detecting An Adversary

Once the base station finds the node who sent NACK during the verification of inclusion phase, it interacts with the nodes in the network to trace an adversary responsible for it. The base station tries to construct a set of possible adversaries based on a set of possible cheaters. The following example demonstrates that if the base station knows the commitment tree topology and the complainers in the network then it can guess the possible adversaries. For simplicity, we selected the commitment tree where all the vertices are unique. This analysis holds true for any commitment tree topology.

Example 8.3.3 *The base station constructs a set $C = \{C_1, C_2, \dots, C_n\}$ for the complainers based on the protocol described in the Section 8.3.5. Then based on the set C it constructs a set $A = \{A_1, A_2, \dots, A_n\}$ of the possible adversaries.*

Suppose $C = \{A_0\}$ then a possible set of adversary $A = \{I, \{B, I\}, \{B, M\}, \{B, I, M\}\}$. Note the fact that only I knows the exact data-item of A_0 . The vertices M and O

knows aggregated value of A_0 . Hence, if either M or O tampers they tamper with more than one data-item or they have to cheat in a group. Based on the fact that the possible set of adversaries for given complainer set are as follows:

If $C = \{A_0, B_0\}$ then $A = \{I, M, \{I, M\}, \{C, D, O\}\}$

If $C = \{A_0, B_0, C_0\}$ then $A = \{\{D, O\}, \{I, J\}, \{M, J\}, \{M, J, I\}\}$

If $C = \{A_0, B_0, C_0, D_0\}$ then $A = \{M, O, \{I, J\}, \{E, F, G, H, O\}\}$

If $C = \{A_0, B_0, C_0, D_0, E_0\}$ then $A = \{\{O, K\}, \{M, K\}, \{J, I, K\}, \{F, G, H, O\}\}$

If $C = \{A_0, B_0, C_0, D_0, E_0, F_0\}$ then $A = \{\{O, K\}, \{M, N\}, \{N, O\}, \{J, I, K\}\}$

If $C = \{A_0, C_0\}$ then $A = \{\{J, I\}\}$

Now, we describe the case for detecting an adversary for a single complainer case. In above example, if $C = A_0$ then $A = \{I, \{B, I\}, \{B, M\}, \{B, I, M\}\}$. Suppose I is an adversary and it changed the A_0 to A'_0 , creating an internal vertex I'_1 instead of I_1 while creating the commitment tree. Then,

$$I_1 = \langle I_{id}, 1, I_{1value}, H(N||1||I_{value}||A_0||B_0) \rangle \text{ where } I_{1value} = A_{value} + B_{value}$$

$$I_{pay} = \langle I_1, \text{Sign}_{sk_I}(I_1), \text{Sign}_{sk_I}(I_\tau) \rangle \text{ where } I_\tau = I_1$$

Whereas,

$$I'_1 = \langle I_{id}, 1, I'_{1value}, H(N||1||I'_{value}||A'_0||B_0) \rangle \text{ where } I'_{1value} = A'_{value} + B_{value}$$

$$I'_{pay} = \langle I'_1, \text{Sign}_{sk_{I'}}(I'_1), \text{Sign}_{sk_{I'}}(I_\tau) \rangle \text{ where } I_\tau = I'_1,$$

To detect an adversary, first the base station asks A to send its payload.

$$A_{pay} = \langle A_0, \text{Sign}_{sk_A}(A_0), \text{Sign}_{sk_A}(A_\tau) \rangle \text{ where } A_\tau = A_0$$

$$A_0 = \langle A_{id}, 1, A_{value}, H(N||1||A_{value}) \rangle$$

Then the base station asks I to send all the received payloads from each of its children and its own payload. So, I instead of sending the its true payload it sends its false payload to the base station. As I is an adversary it might lie about it and send the following payload.

$$A_{pay} = \langle A_0, \text{Sign}_{sk_A}(A_0), \text{Sign}_{sk_A}(A_\tau) \rangle \text{ where } A_\tau = A_0$$

$$B_{pay} = \langle B_0, \text{Sign}_{sk_B}(B_0), \text{Sign}_{sk_A}(B_\tau) \rangle \text{ where } B_\tau = B_0$$

$$I_{pay} = \langle I_1, \text{Sign}_{sk_I}(I_1), \text{Sign}_{sk_A}(I_\tau) \rangle \text{ where } I_\tau = I_0$$

Then the base station asks M to send all the received payload from each of its children. So, M sends the following to the base station.

$$I'_{pay} = \langle I'_1, \text{Sign}_{sk_1}(I'_1), \text{Sign}_{sk_1}(I_\tau) \rangle \text{ where } I_\tau = I'_1$$

$$J_{pay} = \langle J_1, \text{Sign}_{sk_1}(J_1), \text{Sign}_{sk_A}(J_\tau) \rangle \text{ where } J_\tau = J_0$$

As the base station receives the I'_{pay} with a signature from M , then this proves that the I has lied about its payload. Hence, I is an adversary. In general, the bases station utilizes the following algorithm to trace an adversary.

Algorithm 3 Pseudo algorithm to detect an adversary

- 1: BS identifies all the complainer and constructs $C = \{C_1, C_2, \dots, cC_n\}$
 - 2: **for all** $C \in C$ **do**
 - 3: BS asks C to send data-item with its signature, sent during commitment tree generation phase
 - 4: BS identifies possible adversary based on C and constructs $A = \{A_1, A_2, \dots, A_n\}$
 - 5: **for all** $A \in A$ **do**
 - 6: BS asks A to send data-items with its signature, received and sent by A during commitment tree generation phase
 - 7: If needed BS asks the parent of A to send data-items with its signature
 - 8: BS determines the adversary based on the verification of signatures
-

If an an adversary tempers with the data-item without being detected then it breaks the data-integrity of the protocol. Once the base station detects adversaries it dispels them from the network for all the future queries. Doing so removes unnecessary communication for debugging purpose in the future. Hence, saves the bandwidth and increases the longevity of the network.

8.4 Analysis

Our protocol creates a complete binary tree for any given aggregation tree. Hence, if we have n nodes in an aggregation tree, then at max there will be $2^{\lg n+1} - 1 = 2n - 1$

vertices in the commitment tree. In both the approaches FS_wRD and FS_woRD, there are at least two signatures associated with all the vertices in the commitment tree. Hence, there are at least $2(2n - 1)$ signatures created while creating the commitment tree. In general, an intermediate node with n descendants receives $\lceil \log_2 n \rceil$ trees from its children. As we know, there are at least two signatures associated with each vertex, the node with n descendants receives at least $2\lceil \log_2 n \rceil$ signatures.

We claim that the binary representation of a non-negative number x illustrates the payload decomposition of the sensor node S , where $x = 1 + \text{number of descendants of } S$. For example, if sensor node S has 22 descendants then $x = 23$, $(x)_{10} = (10111)_2$. This means S has four complete binary trees in its payload, with the height of four, two, one and zero. Note that all the trees in the commitment payload are complete binary trees and no two trees have the same height. The reason 1 is added to the descendants of S is that the sensor node itself is collecting data.

In both the approaches FS_wRD and FS_woRD, the number of transmitted signatures within the network remain the same as shown in Table 8.1 (we ignore the signature of the payload). But the number of times a data-item is being signed differ in both the approaches which impacts the number of certificates being transmitted in the network. The certificate is large in size and consumes a lot of bandwidth during the transmission. To do the further analysis, we developed a performance matrix based on number of transmitted certificates for commonly used network topologies. We analyzed different network topologies as shown in Table 8.2.

Table 8.1.: Totality of Signatures Transmitted

Network Topology	FS _w RD	FS _w oRD
Star	$2n$	$2n$
Palm Tree	$2n$	$2n$
Complete Binary	$2n$	$2n$

Table 8.2.: Totality of Certificates

Network Topology	FSwRD	FSwoRD
Star	$n - 1$	$n - 1$
Palm Tree	$n - 1$	XX
Complete Binary	$n - 1$	$n - 1$

The following theorem proves that the complete binary tree structure is optimal for commitment tree generation.

Theorem 8.4.1 *Binary commitment tree is optimal in terms of verification for m -ary tree, as it requires minimum number of off-path values.*

Proof Consider the case of a tertiary tree, other m -ary tree arguments following the same manner. Let m be the number of leaves in a commitment tree. For a given binary commitment tree, each leaf vertex needs $\log_2 m$ off-path values in the verification phase. The total off-path values needed in a given commitment tree is $m \log_2 m$. For the given tertiary commitment tree, each leaf vertex needs $2 \log_3 m$ off-path values in the verification phase. The total off-path values needed in given commitment tree is $2m \log_3 m$. We know that, $\log_3 m = \frac{\log_2 m}{\log_2 3}$. Multiplying both sides with $2m$ gives, $2m \log_3 m = 2m \frac{\log_2 m}{\log_2 3} = \frac{2}{\log_2 3} m \log_2 m = (1.2618) m \log_2 m$. Hence, $2m \log_3 m > m \log_2 m$. In totality, the binary commitment tree requires the minimum number of off-path values.

9. CONCLUSION AND FUTURE WORK

In this thesis, we have shown data aggregation is an important primitive to save bandwidth in the sensor network which are becoming pervasive in our day-to-day life. We built our protocol on top of Secure Hierarchical In-network Data Aggregation protocol which provides data integrity to the hash tree. Firstly, we modified the label structure of SHIA to make it more communication efficient by removing the redundant field in its data-item. Secondly, we represent a mathematical way of analyzing the protocol. We also propose an algorithm to find all possible cheaters in the network. In addition, we identify the significance of finding an adversary in a network is critical. We propose an algorithm which can detect an adversary in the network and remove it for all the future queries. Furthermore, we give the proof that complete binary tree is an optimal data structure to build the commitment tree.

The security in unstructured networks without a trusted authority is very hard. It can be simplified by giving structure to the network and trusted authority. In the future, we would like to analyze this protocol for various network topologies and generalized the results. It is our hope that further research can improve the cheater detection algorithm. Furthermore, analyzing these security protocols can provide additional insights into the network models that closely represent the real-world applications.

LIST OF REFERENCES

LIST OF REFERENCES

- [1] M. Weiser, “The computer for the 21st century,” *Scientific american*, vol. 265, no. 3, pp. 94–104, 1991.
- [2] F. Stajano, *Security for Ubiquitous Computing*. John Wiley & Sons, Feb. 2002.
- [3] K. Ashton, “That internet of things thing,” *RFiD Journal*, vol. 22, no. 7, pp. 97–114, 2009.
- [4] Uber. <https://www.uber.com/>. LAST DATE ACCESSED: February 25, 2015.
- [5] Final report of airbus a330-203. <http://www.bea.aero/docspa/2009/f-cp090601.en/pdf/f-cp090601.en.pdf>. LAST DATE ACCESSED: February 25, 2015.
- [6] Anthem inc.’s data breach. <http://www.bloomberg.com/news/articles/2015-02-05/signs-of-china-sponsored-hackers-seen-in-anthem-attack>. LAST DATE ACCESSED: February 23, 2015.
- [7] M. Weiser, R. Gold, and J. S. Brown, “The origins of ubiquitous computing research at parc in the late 1980s,” *IBM systems journal*, vol. 38, no. 4, pp. 693–696, 1999.
- [8] H.-J. Hof, “Applications of sensor networks,” in *Algorithms for Sensor and Ad Hoc Networks*. Springer, 2007, pp. 1–20.
- [9] D. Li, K. D. Wong, Y. H. Hu, and A. M. Sayeed, “Detection, classification, and tracking of targets,” *Signal Processing Magazine, IEEE*, vol. 19, no. 2, pp. 17–29, 2002.
- [10] M. Chu, J. Reich, and F. Zhao, “Distributed attention in large scale video sensor networks,” in *Intelligent Distributed Surveillance Systems, IEE*. IET, 2004, pp. 61–65.
- [11] J. D. Lundquist, D. R. Cayan, and M. D. Dettinger, “Meteorology and hydrology in yosemite national park: A sensor network application,” in *Information Processing in Sensor Networks*. Springer, 2003, pp. 518–528.
- [12] R. Benenson, S. Petti, T. Fraichard, and M. Parent, “Towards urban driverless vehicles,” *International Journal of Vehicle Autonomous Systems*, vol. 6, no. 1, pp. 4–23, 2008.
- [13] M. D. Addlesee, A. Jones, F. Livesey, and F. Samaria, “The orl active floor,” *IEEE Personal Communications*, vol. 4, pp. 35–41, 1997.

- [14] K. Lorincz, D. J. Malan, T. R. Fulford-Jones, A. Nawoj, A. Clavel, V. Shnyder, G. Mainland, M. Welsh, and S. Moulton, "Sensor networks for emergency response: challenges and opportunities," *Pervasive Computing, IEEE*, vol. 3, no. 4, pp. 16–23, 2004.
- [15] H. Karl and A. Willig, *Protocols and architectures for wireless sensor networks*. John Wiley & Sons, 2007.
- [16] N. S. Shenck and J. A. Paradiso, "Energy scavenging with shoe-mounted piezoelectrics," *Ieee Micro*, vol. 21, no. 3, pp. 30–42, 2001.
- [17] A. Wang and A. Chandrakasan, "Energy-efficient dsps for wireless sensor networks," *Signal Processing Magazine, IEEE*, vol. 19, no. 4, pp. 68–78, 2002.
- [18] M. Ettus, "System capacity, latency, and power consumption in multihop-routed ss-cdma wireless networks," in *Radio and Wireless Conference, 1998. RAWCON 98. 1998 IEEE*. IEEE, 1998, pp. 55–58.
- [19] D. Wagner and R. Wattenhofer, *Algorithms for sensor and ad hoc networks: advanced lectures*. Springer-Verlag, 2007.
- [20] J. L. Hill and D. E. Culler, "Mica: A wireless platform for deeply embedded networks," *Micro, IEEE*, vol. 22, no. 6, pp. 12–24, 2002.
- [21] O. Arazi, I. Elhanany, D. Rose, H. Qi, and B. Arazi, "Self-certified public key generation on the intel mote 2 sensor network platform," in *2nd IEEE Workshop on Wireless Mesh Networks, 2006. WiMesh 2006*. IEEE, 2006, pp. 118–120.
- [22] M. Bishop, *Introduction to computer security*. Addison-Wesley Professional, 2004.
- [23] A. J. Menezes, P. C. Van Oorschot, and S. A. Vanstone, *Handbook of applied cryptography*. CRC press, 2010.
- [24] sha256 standards from nist. <http://csrc.nist.gov/groups/STM/cavp/documents/shs/sha256-384-512.pdf>. LAST DATE ACCESSED: January 9, 2015.
- [25] Digital signature. http://en.wikipedia.org/wiki/Digital_signature#mediaviewer/File:Digital_Signature_diagram.svg. LAST DATE ACCESSED: January 9, 2015.
- [26] B. Krishnamachari, D. Estrin, and S. Wicker, "The impact of data aggregation in wireless sensor networks," in *22nd International Conference on Distributed Computing Systems Workshops, 2002*. IEEE, 2002, pp. 575–578.
- [27] Routing river image. http://www.cse.msu.edu/rgroups/elans/project_files/wsn_project2.html. LAST DATE ACCESSED: January 16, 2015.
- [28] S. ZareAfifi, R. Verma, B. King, P. Salama, and D. Kim, "Secure countermeasures to data aggregation attacks on sensor networks," in *IEEE 55th International Midwest Symposium on Circuits and Systems (MWSCAS)*. IEEE, 2012, pp. 856–859.
- [29] S. Madden, M. J. Franklin, J. M. Hellerstein, and W. Hong, "Tag: A tiny aggregation service for ad-hoc sensor networks," *ACM SIGOPS Operating Systems Review*, vol. 36, no. SI, pp. 131–146, 2002.

- [30] Payload computing. [http://en.wikipedia.org/wiki/Payload_\(computing\)](http://en.wikipedia.org/wiki/Payload_(computing)). LAST DATE ACCESSED: January 9, 2015.
- [31] S. Madden, M. J. Franklin, J. M. Hellerstein, and W. Hong, “The design of an acquisitional query processor for sensor networks,” in *Proceedings of the 2003 ACM SIGMOD international conference on Management of data*. ACM, 2003, pp. 491–502.
- [32] D. Wagner, “Resilient aggregation in sensor networks,” in *Proceedings of the 2nd ACM workshop on Security of ad hoc and sensor networks*. Organization, 2004, pp. 78–87.
- [33] H. Chan, A. Perrig, and D. Song, “Secure hierarchical in-network aggregation in sensor networks,” in *Proceedings of the 13th ACM conference on Computer and communications security*. ACM, 2006, pp. 278–287.
- [34] L.-G. Alberto and W. Indra, “Communication networks: fundamental concepts and key architectures,” *Mc GrawHill*, pp. 845–857, 2000.
- [35] Nsidc weather report on arctic sea. <http://nsidc.org/arcticseaicenews/2008/06/arctic-sea-ice-still-on-track-for-extreme-melt/>. LAST DATE ACCESSED: January 30, 2015.
- [36] Dmsp-f13. http://nsidc.org/data/docs/daac/f13_platform.gd.html. LAST DATE ACCESSED: January 30, 2015.
- [37] Dmsp-f15. http://nsidc.org/data/docs/daac/f15_platform.gd.html. LAST DATE ACCESSED: January 30, 2015.
- [38] Y. Yao and J. Gehrke, “The cougar approach to in-network query processing in sensor networks,” *ACM Sigmod Record*, vol. 31, no. 3, pp. 9–18, 2002.
- [39] B. Przydatek, D. Song, and A. Perrig, “Sia: Secure information aggregation in sensor networks,” in *Proceedings of the 1st international conference on Embedded networked sensor systems*. ACM, 2003, pp. 255–265.
- [40] W. Stallings and L. Brown, *Computer Security*. Pearson Education, 2008, no. s 304.
- [41] C. P. Pfleeger and S. L. Pfleeger, *Security in computing*. Prentice Hall Professional Technical Reference, 2002.
- [42] R. Anderson, “Why cryptosystems fail,” in *Proceedings of the 1st ACM Conference on Computer and Communications Security*. ACM, 1993, pp. 215–227.
- [43] ECDSA-FIPS, “186-3,” *Digital Signature Standard (DSS)*, 2009. http://csrc.nist.gov/publications/fips/fips186-3/fips_186-3.pdf LAST DATE ACCESSED: February 25, 2015.