

2019

# Eye-Tracking Attentional Deployment: Emotion Regulation and Processing Visual Information in University Students

Abirami R. Kandasamy  
*University of Windsor*

Follow this and additional works at: <https://scholar.uwindsor.ca/etd>

---

## Recommended Citation

Kandasamy, Abirami R., "Eye-Tracking Attentional Deployment: Emotion Regulation and Processing Visual Information in University Students" (2019). *Electronic Theses and Dissertations*. 7711.  
<https://scholar.uwindsor.ca/etd/7711>

This online database contains the full-text of PhD dissertations and Masters' theses of University of Windsor students from 1954 forward. These documents are made available for personal study and research purposes only, in accordance with the Canadian Copyright Act and the Creative Commons license—CC BY-NC-ND (Attribution, Non-Commercial, No Derivative Works). Under this license, works must always be attributed to the copyright holder (original author), cannot be used for any commercial purposes, and may not be altered. Any other use would require the permission of the copyright holder. Students may inquire about withdrawing their dissertation and/or thesis from this database. For additional inquiries, please contact the repository administrator via email ([scholarship@uwindsor.ca](mailto:scholarship@uwindsor.ca)) or by telephone at 519-253-3000ext. 3208.

**Eye-Tracking Attentional Deployment: Emotion Regulation and Processing Visual**

**Information in University Students**

By

**Abirami Ravichakaravarthy Kandasamy**

A Dissertation

Submitted to the Faculty of Graduate Studies  
through the Department of Psychology  
in Partial Fulfillment of the Requirements for  
the Degree of Doctor of Philosophy  
at the University of Windsor

Windsor, Ontario, Canada

2019

© 2019 Abirami R. Kandasamy

**Eye-Tracking Attentional Deployment: Emotion Regulation and Processing Visual  
Information in University Students**

by

**Abirami R. Kandasamy**

APPROVED BY:

---

D. Smilek, External Examiner  
University of Waterloo

---

N. McNevin  
Faculty of Human Kinetics

---

L. Buchanan  
Department of Psychology

---

R. Menna  
Department of Psychology

---

J. Hakim-Larson, Advisor  
Department of Psychology

April 25, 2019

## **DECLARATION OF ORIGINALITY**

I hereby certify that I am the sole author of this thesis and that no part of this thesis has been published or submitted for publication.

I certify that, to the best of my knowledge, my thesis does not infringe upon anyone's copyright nor violate any proprietary rights and that any ideas, techniques, quotations, or any other material from the work of other people included in my thesis, published or otherwise, are fully acknowledged in accordance with the standard referencing practices. Furthermore, to the extent that I have included copyrighted material that surpasses the bounds of fair dealing within the meaning of the Canada Copyright Act, I certify that I have obtained a written permission from the copyright owner(s) to include such material(s) in my thesis and have included copies of such copyright clearances to my appendix.

I declare that this is a true copy of my thesis, including any final revisions, as approved by my thesis committee and the Graduate Studies office, and that this thesis has not been submitted for a higher degree to any other University or Institution.

## ABSTRACT

Attentional deployment is an emotion regulation strategy in which individuals redirect their attentional focus to change their emotional experience (Gross, 2013). At the present time, there is no standardized method of measuring attentional deployment. Some studies have adapted the use of eye-tracking to measure visual attentional deployment while viewing still images (Bebko et al., 2011; Wirth et al., 2018). The present research used novel methodology, in two studies, to operationally define attentional deployment and work toward a standardized measurement tool for attentional deployment (via eye-tracking). This research explores attentional deployment in relation to other emotion regulations strategies, how symptoms of disordered attention, as seen in Attention Deficit Hyperactivity Disorder (ADHD), relate to use of emotion regulation strategies, and explores emotion appraisal in attentional deployment.

Participants in both studies were undergraduate students at a medium-sized, ethnically diverse, university in southwestern Ontario. Two separate studies were conducted with identical methodology, apart from the the eye-tracking task. The emotionally charged stimuli presented during the eye-tracking task were either realistic video clips of people or a video clip of moving shapes, often interpreted as a negative interaction.

In Study 1 (N = 89), participants were shown five randomized clips from the motion picture, “The Perks of Being a Wallflower” (Halfon, Smith, Malkovich, & Chbosky, 2012) and rated each clip as evoking positive or negative emotions. Three clips were used for analyses. One clip was rated by all participants as evoking negative emotions, and another clip was rated by all participants as evoking positive emotions; the third clip was ambiguous (i.e., 44 participants rated the clip as positive and 45 rated it as negative). In Study 2 (N = 98), participants viewed Heider and Simmel’s (1944) short film of moving shapes, often anthropomorphized and

interpreted as a negative interaction (Klin, 2000). Participants' ADHD symptoms, self-reported impulsivity, behavioural impulsivity, and emotion regulation strategies were also collected for both studies.

Participants demonstrated greater attentional deployment (attention directed away from evocative areas in the video clip) when viewing the negative clip than the ambiguous clip, and the least attentional deployment when viewing the positive clip. Average pupil diameter was largest during the negative clip, smaller for the positive clip, and smallest for the ambiguous clip. Greater attentional deployment in the positive clip and the ambiguously evocative clip predicted greater use of cognitive reappraisal strategies and greater use of expressive suppression strategies, respectively. As well, participants in Study 1 with higher self-reported ADHD symptoms (and higher impulsivity) reported using less cognitive reappraisal strategies than participants with lower self-reported ADHD symptoms. However, this result was not replicated in Study 2. A post-hoc analysis showed that participants in Study 2 endorsed much higher levels of impulsivity (i.e., in the clinical range) than did participants in Study 1.

Findings highlight the potential for using eye-tracking as a standardized research tool to measure visual attentional deployment. The results also suggest that different mechanisms may underlie the processes of attentional deployment, cognitive reappraisal, and expressive suppression such that different valence stimuli elicit different types of emotion regulation responses. In addition, greater attentional deployment away from evocative areas of the stimuli occurred when viewing video clips evoking negative emotions rather than positive emotions and this was consistently demonstrated for both video clips of people and the video of moving shapes, highlighting the importance of participants' emotional appraisal of events for the process of emotion regulation.

## **DEDICATION**

This project is dedicated to my Amma and Appa, to my sister, Tharsha, and to Shirdi, Rani and Duke for their endless support, inspiration, and love.

## ACKNOWLEDGEMENTS

This dissertation could not have been completed without the guidance and support of many.

First, I would like to express gratitude to my research supervisor, Dr. Julie Hakim-Larson, one of my biggest cheerleaders, for her guidance and encouragement on this project and in life. Special thanks to my dissertation committee members. Thank you to Dr. Lori Buchanan for allowing me to work with her eye tracking equipment and her entertaining quips in the basement of CHS. As well, thank you to her postdoctoral fellow, Vince, for helping me with the development of my programming. Thank you to Dr. Menna, my clinical, and now research, mentor after whom I wish to model my clinical practice. Thank you to Dr. McNevin, who started me on this journey with eye-tracking research by collaborating with me for my Masters project. I must give a special thank you to my best friends and fellow students for their love, support, and help with this project: Jillian Glasgow, Tharsha Ravichakaravarthy, Daniela Wong-Gonzales, and Molly Cairncross. Lastly, I would like to extend a thank you to my friends and colleagues for their encouragement and camaraderie.



## TABLE OF CONTENTS

<b>DECLARATION OF ORIGINALITY</b> .....	iii
<b>ABSTRACT</b> .....	iv
<b>DEDICATION</b> .....	vi
<b>ACKNOWLEDGEMENTS</b> .....	vii
<b>LIST OF TABLES</b> .....	x
<b>LIST OF FIGURES</b> .....	xi
<b>LIST OF APPENDICES</b> .....	xii
<b>CHAPTER 1 INTRODUCTION</b> .....	1
Overview .....	1
Overview: Emotion Regulation .....	4
The Process Model of Emotion Regulation .....	5
Emotion Regulation and ADHD .....	17
The Present Research: Study 1 and Study 2 .....	18
Study 1 Research Questions and Hypotheses .....	20
<i>Research Question 1 (RQ1)</i> .....	20
<i>Research Question 2 (RQ2)</i> .....	21
<i>Research Question 3 (RQ3)</i> .....	22
Study 2 Research Questions and Hypotheses .....	24
<i>Research Question 4 (RQ4)</i> .....	24
<i>Research Question 5 (RQ5)</i> .....	24
Comparing Study 1 and 2 .....	25
<i>Research Question 6 (RQ6)</i> .....	24
<b>CHAPTER 2 METHOD</b> .....	29
Participants .....	29
Measures and Apparatus .....	30
General Procedure .....	43

Eye-tracking procedure for Study 1 .....	44
Eye-tracking procedure for Study 2 .....	44
<b>CHAPTER 3 RESULTS</b> .....	46
Preliminary Analyses (Study 1 and 2) .....	46
Study 1 Results .....	56
Study 2 Results .....	61
Results Comparing Study 1 and Study 2 .....	65
<b>CHAPTER 4 DISCUSSION</b> .....	71
<b>REFERENCES</b> .....	89
<b>APPENDICES</b> .....	104
<b>VITA AUCTORIS</b> .....	121

## LIST OF TABLES

Table 1	Summary of Hypotheses for Both Studies.....	27
Table 2	List of Measures, Study Variables, and Units of Measurement for Study 1 and 2.....	31
Table 3	Number of Participants who Rated Video Clips from “The Perks of Being a Wallflower” per Valence .....	40
Table 4	List of Hypotheses, Study Variables, Measures, and Analyses for Study 1 and 2.....	47
Table 5	Descriptive Statistics (Including Mean, SD, Skewness, Kurtosis) for Study 1 Continuous Variables.....	49
Table 6	Correlation Table for All Variables in Study 1.....	51
Table 7	Correlation Table for All Variables in Study 2.....	52
Table 8	Descriptive Statistics (Including Mean, SD, Skewness, Kurtosis) for Study 2 Continuous Variables.....	54
Table 9	Hierarchical Multiple Regression Analysis Predicting Cognitive Reappraisal from Attentional Deployment in Study 1.....	59
Table 10	Hierarchical Multiple Regression Analysis Predicting Expressive Suppression from Attentional Deployment when Viewing Videos Rated as Relatively Negative in Study 1 .....	60
Table 11	Hierarchical Multiple Regression Analysis Predicting Cognitive Reappraisal from Attentional Deployment in Study 2.....	63
Table 12	Hierarchical Multiple Regression Analysis Predicting Expressive Suppression from Attentional Deployment in Study 2 .....	64
Table 13	Descriptive Statistics (Including Mean, SD, and range) for Study 1 and 2 Continuous Variables.....	66
Table 14	Summary of Hypotheses and Results for Both Studies .....	69

## LIST OF FIGURES

Figure 1	Example of areas of interest for people and background.....	36
Figure 2	Example image of precision when defining areas of interest frame by frame to capture movement.....	37
Figure 3	Still from the film of moving shapes showing the areas of interest for characters and background.....	42

## LIST OF APPENDICES

Appendix A	Glossary of Eye-tracking Terms .....	104
Appendix B	Frequencies of Demographic Variables for Study 1 and Study 2 .....	105
Appendix C	Permissions Table .....	107
Appendix D	Demographic Form .....	108
Appendix E	Programming for Study 1 on Experiment Builder v 2.1.140 .....	110
Appendix F	Programming for Study 2 on Experiment Builder v 2.1.140 .....	114
Appendix G	Consent to Participate in Research.....	115
Appendix H	Resources for Emotional Distress .....	118
Appendix I	Character Labels for the Social Attribution Task.....	120

# CHAPTER 1

## INTRODUCTION

### Overview

In Heider and Simmel's (1944) "An experimental study of apparent behaviour", participants were shown a brief film of moving shapes, called the Social Attribution Task (SAT), to which most participants attributed human characteristics. Over seven decades later, the SAT continues to be used in research and has been adapted to further understanding in numerous areas including social cognition, theory of mind, and visual attention (Ross & Olson, 2010; Schurz, Radua, Aichhorn, Richlan, & Perner, 2014; Wagner, Kelley, & Heatherton, 2011; Yang et al., 2018). This task has been and continues to be a useful tool, with potential to offer insight into the process of emotion regulation.

Emotion regulation is the tracking, appraising, and changing of the intensity and duration of an emotional response (Thompson, 1994). It serves a fundamental role for a variety of functions including daily social interactions, self-esteem, and overall psychological adjustment, particularly for young adults in university (Lopes, Salovey, Côté, & Beers, 2005; Nezlek & Kuppens, 2008; Thompson, 1994). The amygdala has been implicated in a broad range of emotion processes (e.g., processing rewards for motivating behaviours, fear response, and various emotional states) as well as cognitive processes (attention, perception, and explicit memory; LeDoux, 2007). Neuroimaging studies have found amygdala activity when individuals engage in emotion regulation strategies (van Reekum et al., 2007).

The Process Model of Emotion Regulation (Gross 1998a, 1998b) is a model that outlines a course of events that result in the expression of an emotion. These events are all points of time where emotion regulation can occur. Specifically, these include the emotional situation, where

attention is drawn during the situation, emotional appraisal of the situation, and the resultant emotional response. There are five primary methods of regulating emotion in this model based on when emotion regulation occurs, including during the situation (situation selection, situation modification), attention (attentional deployment), appraisal (cognitive change), and response (response modulation) time points. Attentional deployment (directing attention to influence emotions), cognitive reappraisal (changing the way you think about an emotional event), and expressive suppression (changing the physical expression of the emotion experienced) are internal processes that impact the emotion experience and emotion expression, which differ from situation selection (choosing to enter/avoid an emotionally evocative situation) and situation modification (making a change to the setting to influence emotions) that are examples of environmental changes (Gross, 2013). The present research specifically focuses on the internal emotion regulation strategies: attentional deployment, cognitive reappraisal, and expressive suppression.

Research shows that compared to other emotion regulation strategies such as cognitive reappraisal or expressive suppression, attentional deployment takes minimal effort (Sheppes & Gross, 2011). When using attentional deployment, the individual disengages from attending to an evocative stimulus and redirects their attention to change the experience of the evoked emotion (Bargh & Williams, 2007). Attentional deployment has been measured using different methodologies, making study comparisons difficult. Historically, attentional deployment was measured indirectly and was inferred by measuring mood before and after a task where the participant was instructed to deploy attention (Goldin & Gross, 2010; Johnson, 2009). Currently, eye-tracking can and has been used to study attentional deployment because it can precisely

measure where a person is looking within defined parameters (such as a computer screen), which serves as an analogue for visual attention (Kimble, 2010).

The aim of the present research was to use eye-tracking to further understand the process of attentional deployment. This was done by exploring four objectives. The first objective was to identify whether attentional deployment can be measured directly using eye-tracking when viewing videos, rather than still images. To date, studies have used eye-tracking to directly measure attentional deployment while participants view still images but not videos (Bebko, Franconeri, Ochsner, & Chiao, 2011). The second objective was to explore the relationship between attentional deployment and other emotion regulation strategies, namely, cognitive reappraisal and expressive suppression. The third objective was to explore how individuals with relatively higher and lower attention deficit hyperactivity disorder (ADHD) symptomology (inattention, hyperactivity, and impulsivity) differed in their use of emotion regulation strategies. Finally, the fourth objective of this project was to compare attentional deployment when viewing emotionally-evocative video clips with humans to attentional deployment when viewing a clip of moving shapes that evokes negative emotions, and determine if a film without human cues can result in a similar visual response and need to regulate as a clip with human cues (Heberlein & Adolphs, 2004; Heider & Simmel, 1944).

To test these four objectives, two studies with identical methodology were conducted. The only difference in the two studies was the video stimuli presented during the eye-tracking task. Both studies measured participants' demographic variables, attention deficit hyperactivity disorder symptoms, self-reported impulsivity, behavioural impulsivity, and emotion regulation. In Study 1, video clips from the motion picture "The Perks of Being a Wallflower" (Halfon et al.,



2012) were used as realistic situations with similarly aged people as the participants. In Study 2, Heider and Simmel's (1944) film of moving shapes was shown.

The literature review below includes an overview of emotion regulation research, the process model of emotion regulation (with a particular focus on attentional deployment), measurement approaches for the study of attentional deployment, eye-tracking in relation to attentional deployment, and adapting attentional deployment to a film of moving shapes. As well, psychopathology is discussed in the context of emotion regulation with a focus on ADHD and the symptom of impulsivity. Following the literature review as well as the research questions and hypotheses for both studies, are descriptions of the research method, the results, and a discussion of implications.

### **Overview: Emotion Regulation**

Regulating emotions serves a fundamental role for a variety of functions including daily social interactions, self-esteem, and overall psychological adjustment for young adults in university (Lopes et al., 2005; Nezlek & Kuppens, 2008). Emotion regulation occurs throughout the lifespan and has been defined as processes responsible for monitoring, evaluating, and changing the intensity and duration of emotional reactions (Scheibe & Zacher, 2013; Thompson, 1994). Emotion regulation is often a focus of clinical intervention because effective emotion regulation can promote positive and successful interpersonal relationships, mental health, physical health, and adaptive functioning (Aldao, Nolen-Hoeksema, & Schweizer, 2010; Berking & Wupperman, 2012; Lopes et al., 2005; Zimmerman & Iwanski, 2014; Tamir, 2011).

There are multiple factors that contribute to the way in which emotions are experienced and expressed (emotion regulation). It has been theorized that individuals are primarily motivated to regulate their emotions in order to pursue instrumental goals such as changes in

physiology (e.g., changing heart rate), thoughts, or behavior (Tamir, 2011). An example of using emotion regulation to pursue an instrumental goal is suppressing laughter when you see your friend fall down. In this situation, regulating the evoked emotion could meet the instrumental goal to preserve a positive relationship by avoiding humiliating your friend. How adaptive emotion regulation is varies based on level of analysis. The level of analysis can include a temporal level (e.g., short-term vs. long-term) and/or whom the decision may affect (e.g., self vs. others; Tamir, 2011). In the given example, a long-term consequence to not laughing may be maintaining the relationship with your friend. The same situation can evoke different emotions, which would in-turn influence the need to regulate. In the example of viewing your friend falling, while one person may be inclined to laugh, another might experience fear of the friend being hurt. These differences can be due to variations in emotional appraisals and can be informed by a variety of factors including attribution schemas (how one ascribes causality), what information is being attended to (e.g., contextual cues, body language, vocal tone), physiological sensitivity (e.g., proneness to heart racing), and precipitating emotional states (Scherer, Schorr, & Johnson, 2001; Tyang, Amin, Saad, & Malik, 2017). In a study of interpreting neutral faces, appraisals of the faces differed depending on varying head tilts (e.g., forward vs. backward) and sex of the face actor, with participants perceiving a woman with a neutral face and head tilting backward as smiling compared to men with a neutral face ( $N = 64$ ; Mignault & Chaudhuri, 2003). The process of appraisal is also a key feature of determining when and how to regulate emotions.

### **The Process Model of Emotion Regulation**

In the Process Model of Emotion Regulation (Gross 1998a, 1998b) an emotionally evocative situation (internal or external) brings attention to the situation, which then incites an

appraisal of the situation, and, finally, results in the emotional response. The emotional response can then influence the situation, providing feedback from the emotional experience (Gross, 2013). Gross (2013) notes that feedback can occur at any point in this model and emotion generation is an ongoing process that extends beyond a single episode. In this model, emotion-regulation can occur through situation selection, situation modification, attentional deployment, cognitive change (e.g., cognitive reappraisal), and response modulation (e.g., expressive suppression).

Situation selection is the process of taking actions that will either increase or decrease the likelihood of being in a situation that elicits specific emotions (e.g., avoiding an irritable coworker to reduce your anxious feelings; Mesquita, De Leersnyder, & Albert, 2013). Situation modification refers to directly altering a situation to change the emotion it elicits (e.g., keeping a family photograph in your office at work so you feel happier). Attentional deployment refers to using attention to influence the experience of emotions (e.g., looking at the clock when your friend is crying to reduce your own feelings of distress; Gross, 2013). Cognitive change is altering the evaluation of a situation to modify the emotional significance. An example of cognitive change is cognitive reappraisal to reduce feelings of distress (e.g., thinking that a friend did not text you back right away because they are busy rather than angry with you). Finally, response modulation is when one modifies the experience, behaviour, or physiology of an emotional expression (Gross, 2013). An example of this strategy is inhibiting emotional expression by expressive suppression (e.g., when you refrain from laughing at your friend who fell down; Gross, 2013).

Situation selection and situation modification are two emotion regulation strategies that require behavioural interaction with the environment. Cognitive reappraisal, expressive

suppression, and attentional deployment are internal emotion regulation strategies that will be the focus of the present research. These emotion regulation strategies will be discussed in greater detail below.

**Cognitive reappraisal.** Emotional experiences can be modified by changing thoughts about the situation or how to manage the situation. This process is called cognitive reappraisal (Gross, 2013). Cognitive appraisals, of a given situation, are influenced by how one interprets and perceives the world. Research shows that individuals spontaneously interpret their surroundings with social meaning and this interpretation extends beyond humans to nature and even inanimate objects; as can be seen in Heider and Simmel's (1944) Social Attribution Task, a film of simple moving geometric shapes that is often interpreted as a negative interaction between human figures (Heberlein & Adolphs, 2004). In the appraisal stage of emotion regulation, meaning making plays a pivotal role in generating emotions and takes place through the interpretation of external surroundings, which changes internal states (Gross & Barrett, 2011).

The use of cognitive reappraisal has been associated with overall healthier social functioning behaviours, affect, and well-being than when using expressive suppression (Cutuli, 2014). One study followed typically-developed individuals ( $N = 153$ ;  $M_{age} = 18.7$  years) for an average of three weeks and had participants report on their use of cognitive reappraisal and expressive suppression to regulate positive and negative emotional experiences (Nezlek & Kuppens, 2008). The study found that the use of cognitive reappraisal, particularly of positive emotions, was beneficial, improving positive affect, psychological adjustment, and self-esteem. The use of cognitive reappraisal on negative emotions also showed improvements on psychological adjustment. Gender differences have been demonstrated through an fMRI study

where the participants completed a cognitive reappraisal task. Men ( $N = 12$ ;  $M_{age} = 20.60$  years) showed less activity in brain regions associated with cognitive reappraisal (the prefrontal region) and greater decreases in amygdala activity, which is associated with emotion processing, when compared to women ( $N = 13$ ,  $M_{age} = 20.36$  years; McRae, Ochsner, Mauss, Gabrieli, & Gross, 2008). van Reekum and colleagues (2007) completed a neuroimaging study that found gaze patterns accounted for 30% of amygdala activity while completing a cognitive reappraisal task, suggesting that attention may be related to the process of cognitive reappraisal. Gross and John's (2003) Emotion Regulation Questionnaire is a widely used self-report measure that quantifies overall use of cognitive reappraisal as well as expressive suppression strategies (Nezlek & Kuppens, 2008).

**Expressive suppression.** Expressive suppression is a response focused strategy where one changes the experience of an emotion by refraining from expressing the natural physical response of an emotion (e.g., to make a neutral face, when the urge is to grimace, to reduce the experience of disgust; Fustos, Gramann, Herbert, & Pollatos, 2012). Experimental studies have demonstrated that prolonged emotional suppression leads to increased blood pressure, less rapport, and prevents relationship formation (Gross, 2013). Individuals who engage in more suppression strategies have been found to experience greater discomfort sharing both positive and negative emotions in close relationships, report avoidance of close relationships, and demonstrate less positive relationships with others overall (English, John, & Gross, 2013; Gross, 2013; Haga, Kraft, & Corby, 2009; Harris, 2001; Kashdan & Steger, 2006; Moscovitch et al., 2011). Though expressive suppression is adaptive in the short-term, prolonged use of expressive suppression of positive emotions has been related to experiencing more negative emotions, less positive emotions, and worsening psychological adjustment (Nezlek & Kuppens, 2008).

Expressive suppression results in problematic social interactions because it prevents accurate interpretation of emotions experienced by social partners.

**Attentional deployment.** The function of attentional deployment is to disengage from attending to the stimulus evoking the unwanted emotion in order to change the experience of that emotion (Bargh & Williams, 2007). Researchers suggest that minimal effort is needed to implement attentional deployment compared to cognitive reappraisal or expressive suppression, which makes it an appealing strategy for practical applications (Sheppes & Gross, 2011). Distraction is an example of an attentional deployment strategy which can take place through a shift in attention toward a new stimuli or to a specific mental operation, like counting when angry (Bargh & Williams, 2007). A meta-analysis on studies addressing the effectiveness of emotion regulation strategies from Gross' Process Model (2013) showed that until 2009, attentional deployment was measured through distraction or concentration tasks (Webb et al., 2012). Typically, in distraction tasks, participants diverted attention with the goal of either reducing a positive emotion to neutral or changing a negative emotion to positive. In concentration tasks, participants were tasked with focusing on emotions, the meaning of a situation, or a combination of these factors. The meta-analysis showed that distraction was more beneficial than concentration as an attentional deployment strategy (Webb et al., 2012).

Attentional deployment is an adaptive short-term emotion regulation strategy, but it can have negative long-term effects if used for emotional avoidance. One study found that over time, distraction results in stronger negative emotional responses than that originally elicited by the evocative stimuli (Thiruchselvam, Blechert, Sheppes, Rydstrom, & Gross, 2011). As described further below, previous studies typically used mood ratings pre- and post- experimental conditions (e.g., distraction or concentration tasks) as an indirect measure of attentional

deployment. More recent studies have combined these strategies with eye-tracking to develop a measure of attentional deployment that is more direct than mood ratings pre- and post-attention deployment task. However, there is still no agreed upon methodology for measuring attentional deployment. The existing methods of measuring attentional deployment will be further explored and serve as the foundational methodology for the procedure in the two studies of the present research.

***Measuring attentional deployment.*** Attentional deployment has been typically measured by distraction tasks that require participants to change their attentional focus (Goldin & Gross, 2010; Johnson, 2009). In a study using mindfulness-based stress reduction, participants with Social Anxiety Disorder engaged in two different types of attentional deployment: a distraction task and a breath-focused task (mindfulness-based stress reduction; MBSR) after evoking negative self-beliefs. Both tasks were designed to redirect participants' attention. Attentional deployment was quantified via proxy measures including depression and anxiety questionnaires and functional magnetic resonance imaging data, measuring activity of the amygdala ( $N = 16$ ;  $M = 35.2$  years; Goldin & Gross, 2010).

Another study used goal-directed attentional deployment where participants ( $N = 109$ ;  $M_{age} = 19.03$  years) completed a stress-inducing anagram task followed by a task where they were shown happy and angry faces (Johnson, 2009). The participants were either instructed to focus attention on happy faces and avoid angry faces or did not have additional instructions. Participants then completed another face task and anagram task. Attentional deployment was approximated by measuring self-reported trait anxiety as well as levels of frustration following the anagram task (Johnson, 2009). Both of these studies used changes reported on mood questionnaires to demonstrate indirect effects of the attentional deployment tasks.

*Eye-tracking attentional deployment.* Eye-tracking is a methodology that measures where someone is looking, which can be considered an analogue for visual attention. This technology continues to improve in quality and accuracy (SR Research, 2016). Studies that have used eye-tracking to measure attentional deployment range from using eye-tracking as a manipulation check to using eye-tracking to directly measure attentional deployment when viewing still images (Bebko et al., 2011; Lohani & Isaacowitz, 2014). Another source of variability in eye-tracking studies is that these studies used different types of evocative stimuli, including still images, video clips, and even physical room conditions.

Before discussing the different studies that have used eye-tracking, it is important to understand common terminology relevant to eye-tracking; namely, fixation duration, eye-gaze, pupil dilation, and areas of interest. A glossary of eye-tracking terms can be found in Appendix A. Fixation duration is the time period that an individual is focused on a point for longer than random scanning patterns (de Wit, 2009). Eye gaze refers to where the individual is looking and has been operationally defined as the sum of all fixation durations in a defined region (Poole & Ball, 2006). Pupil dilation is a nonspecific physical response to arousal and can reveal information about a person's mental state (Lee, Heller, Reekum, Nelson & Davidson, 2012; Marshall, 2007). Areas of interest (AOI) are regions in the image or video, outlined by the researcher, that tells the eye-tracker where to output specific data from (e.g., fixation data that occurred within the AOI; SR Research Ltd., 2016). These terms have been used in eye-tracking studies that measured attentional deployment with both still images and video stimuli as reviewed and discussed next.

*Still images to test attentional deployment.* Eye-tracking has been used to directly measure attentional deployment when viewing still images. Bebko and colleagues (2011)



hypothesized that cognitive reappraisal requires an attentional shift away from emotional triggers before reframing the context. They also hypothesized that expressive suppression may interact with attention deployment in order to be able to make a behavioural change. To test these hypotheses, Bebko and colleagues (2011) showed participants ( $N = 84$ ;  $M_{age} = 19.67$  years) 20 neutral and unpleasant images with specifically defined “emotional” areas of interest based on where participants looked in a pilot study. Participants respond to the images with no instructions, with instructions to use expressive suppression, or with instructions to use cognitive reappraisal. Participants also rated each image on how negatively they felt (Bebko et al., 2011). Attentional deployment was quantified using a rating scale before and after completing a task of directing visual attention toward negative stimuli. Average pupil size was also measured at varying time points through the task and used as an index of arousal. The study concluded that in the expressive suppression and cognitive reappraisal conditions, those who looked toward the emotional areas of a scene, were more likely to reduce their negative affective experience, as measured by a rating scale (Bebko et al., 2011). It should be noted that this study was predicated on still images evoking the same response in all participants, assumed to be negative. This study provides a template for using eye-tracking to directly measure the attentional deployment process and incites further exploration into the interaction between cognitive reappraisal, expressive suppression, and attentional deployment.

In another study that used eye-tracking of images to measure attentional deployment, participants viewed pictures from the International Affective Picture System and were told to attend to circled content while being measured by an eye-tracker (Grühn & Scheibe, 2008; Wirth et al., 2018). An older group ( $N = 42$ ;  $M_{age} = 70.41$  years) and younger group ( $N = 42$ ;  $M_{age} = 26.26$  years) of participants completed three different regulation conditions: no-regulation (not

shown any circled content), away from the stimuli (down-regulation by attending to circled neutral content), or toward the stimuli (up-regulation by attending to circled negative content). Participants reported on their feelings of unpleasantness after each condition. In this study attentional deployment was measured by how effectively participants followed instructions to look at neutral or negative stimuli (as determined by the researchers and as measured by fixation duration; Wirth et al., 2018). As well, negative vs. neutral content were circled for the participants. The study found that during down-regulation, older adults were less likely to direct attention toward the neutral stimulus, but did not experience greater unpleasantness. This finding was attributed to older adults, potentially, being more efficient at attentional deployment. The researchers discussed that the study could have been enhanced by measuring pupil dilation to identify differences in arousal during the different tasks (Wirth et al., 2018).

*Video images to test attentional deployment.* A study by Lohani and Isaacowitz (2014) tested age differences in use of emotion regulation strategies by having younger ( $N = 42$ ;  $M_{age} = 18.5$  years) and older ( $N = 48$ ;  $M_{age} = 71.42$  years) participants watch four video clips that elicit sadness under four conditions: no regulation instructions, attentional deployment, positive reappraisal, and suppression. Attentional deployment was measured by having a condition where participants were requested to not look at negative parts of the scene and then comparing mood ratings to the condition where participants are not given any instructions. The researchers reported using eye-tracking as a manipulation check to ensure that participants followed instructions. When programming the areas of interest, the researchers defined affective areas using ellipses. They gave an example of a video clip from the motion picture “The Champ” (Zeffirelli, 1979) where a boy who is crying and his father’s dead body (covered in blood) are identified as negative areas of interest and where the background was deemed not to have any

emotionally-salient information (i.e., was neutral). Results demonstrated that older adults were more successful at implementing attentional deployment and positive reappraisal, as measured by a mood rating scale. Similar to Wirth and colleagues' study (2018), Lohani and Isaacowitz found that younger participants fixated on negative regions for shorter durations than older participants during the attentional deployment condition but older adults reported better mood than younger adults, which the researchers concluded as indicating older participants demonstrated more effective use of attentional deployment. Lohani and Isaacowitz's (2014) study offers detailed methodology for using video clips as the stimuli. However, the study did not use eye-tracking to directly measure attentional deployment. A limitation of this study is that measuring participants' gaze data as defined using ellipses can be imprecise if the participant is looking away from the negative stimuli but at a location that still falls within the ellipse.

In another study, Isaacowitz and colleagues (2015) used a mobile eye-tracker to measure attentional deployment when participants were in rooms designed to have more negative stimuli (e.g., pictures on the wall, websites on the computer) compared to positive/neutral stimuli. In this study, older participants ( $N = 34$ ;  $M_{age} = 72.27$  years) and younger participants ( $N = 35$ ;  $M_{age} = 19.15$  years) wore the mobile eye-tracker while looking around the rooms, without being told what to attend to, in order to make the results more generalizable. The researchers found that individuals who chose to look at more negative stimuli reported worse moods and those who looked at more positive stimuli reported better mood, regardless of age. However, the researchers concluded, the results of the study were more demonstrative of attentional selection rather than attentional deployment (Isaacowitz, Livingstone, Harris & Marcotte, 2015).

Taken together, these studies lay out strategies for measuring attentional deployment more directly using eye-tracking. Similar to Lohani and Isaacowitz's (2014) study, the present

research used video clips of characters as the stimuli for eye-tracking. Videos allow for real-time measures of visual attention (Klin, 2002). If, in a given scene, the emotional stimuli are the character cues in the clip (e.g., words, vocal tone, and nonverbal body language; Aviezer, Trope, & Todorov, 2012; Lohani & Isaacowitz, 2014), and background information is considered neutral and nonemotional information (Klin, 2000), then attentional deployment can be quantified as a ratio of fixation duration on humans vs. backgrounds during a video clip. For example, individuals who view a video clip that evokes negative emotions, and who are using attentional deployment, might look more at backgrounds (i.e., total fixation durations of backgrounds) than at people (i.e., total fixation durations of all of the people) to regulate their emotions compared to a video clip that evokes positive emotions.

*Adapting attentional deployment to a film of moving shapes.* Human cues and interactions are not the only stimuli that can evoke emotions. In Heider and Simmel's (1944) innovative study, 34 participants viewed a short film clip of moving shapes, called the Social Attribution Task. In the film there is a large triangle, small triangle, and circle that move around the screen and a rectangle that is stationary. Participants were asked to report on what happened in the film and 32 participants described the shapes as people engaging in a negative interaction (two described the shapes as birds). In this study, the majority of people identified the large triangle and the small triangle as engaging in a fight and the rectangle was identified as a house. Use of the Social Attribution Task has evolved over time. This task has been adapted and continues to be used in research on social cognition, attributions of mental states, theory of mind, and social skills, often with individuals with autism spectrum disorder, developmental disorders, and attention deficit hyperactivity disorder (ADHD; Ross & Olson, 2010; Schurz, Radua, Aichhorn, Richlan, & Perner, 2014; Wagner et al., 2011; Yang et al., 2018).

In the Social Attribution Task, participants often interpret the film as a negative interaction (Klin, 2006). Therefore, if this visually simple film of moving shapes evokes negative emotions in the viewer, it may also evoke attentional deployment by the viewer. There is evidence that this video results in changes in visual attention from viewers; for instance, one study used eye-tracking to demonstrate that nonclinical individuals have longer fixation durations when viewing the Social Attribution Task than when viewing another video of shapes moving randomly (Klein, Zwickel, Prinz, & Frith, 2009).

Research suggests that eye-tracking technology can efficiently measure visual attention, and, therefore, provide valuable information about attentional deployment processes (Bebko et al., 2011; Klin, 2000; Lohani & Isaacowitz, 2014). However, individuals who experience disordered attention (e.g., individuals with ADHD) pose a potential challenge for measuring visual attention. For example, in a study of mind wandering ( $N_{non-clinical} = 2708$ ;  $N_{ADHD} = 69$ ,  $N_{matched-control} = 69$  from the larger groups), it was found that individuals with clinically diagnosed ADHD, as well as non-clinical individuals who endorsed higher ADHD symptomology demonstrated more spontaneous mind-wandering as a central ADHD symptom presentation (Seli, Smallwood, Cheyne, & Smilek, 2015). Mind-wandering during a visual attention task, has the potential to affect the measurement of attentional deployment. Studies on attentional deployment, and particularly the studies that have used eye-tracking, have primarily focused on the response of non-clinical populations, therefore further investigation into ADHD symptomology and emotion regulation strategies is warranted (Bebko et al., 2011; Lohani & Isaacowitz, 2014; Urry, 2014).

## **Emotion Regulation and ADHD**

A meta-analysis on emotion-regulation strategies across psychopathology showed that internalizing disorders (characterized by depression, anxiety, and somatic difficulties) were more consistently associated with the use of general regulatory strategies, including emotion regulation (unspecified), when compared to externalizing disorders (characterized by aggressive and hyperactive behaviours;  $N = 114$  studies; Aldao et al., 2010; Cicchetti & Toth, 2014).

Externalizing disorders are characterized by behavioural dysregulation (Kaltiala-Heino, Rimpelä, Rantanen, & Rimpelä, 2000). Individuals with externalizing disorders demonstrate physical expressions of emotion dysregulation, as can be seen in conduct disorder and ADHD (Cappadocia, Desrocher, Pepler, & Schroeder, 2009).

Attention deficit hyperactivity disorder (ADHD) is an externalizing disorder characterized by challenges with inattention and/or hyperactivity and impulsivity (APA, 2013; Kaltiala-Heino, Rimpelä, Rantanen, & Rimpelä, 2000). One research review of ADHD suggested that ADHD symptoms are primarily characterized by breakdowns in the ability to regulate emotions ( $N = 213$ ;  $M_{age} = 33.5$  years; Martel, 2009). Impulsivity is also a diagnostic feature in ADHD and has been related to the emotion-regulation process, with those with greater impulsivity demonstrating poorer emotion regulation in both ADHD and nonclinical populations (APA, 2013; Peckham & Johnson, 2018;  $N_{nonclinical} = 52$ , ages 18-65 years).

**Impulsivity and emotion regulation.** Impulsivity is an important construct to understand because it is a feature in many psychopathologies beyond ADHD, including antisocial personality disorder, bipolar disorder, eating disorders, substance abuse disorder, and conduct disorders (APA, 2013; Beauchaine, & Neuhaus, 2008; Nandagopal et al., 2011). Impulsivity is broadly defined as the tendency to act with less forethought than is typical of

individuals with equal knowledge and ability (Winstanley, Eagle, & Robbins, 2006). It is characterized as a predisposition toward unplanned, swift reactions to stimuli (either external or internal) with, subsequently, little consideration for consequences (Berlin & Hollander, 2008). Impulsivity is a multifaceted construct that has been conceptualized in multiple frameworks. It has been characterized as a state, a trait, fluid, stable, functional, or debilitating, depending on the framework and operational definition (Dougherty et al., 2002; Stanford et al., 2009). The lack of a singular definition makes it difficult to interpret the impulsivity literature. These issues are further complicated by varying methodologies used to capture impulsivity (i.e., self-report vs. behavioural measures) that do not often demonstrate convergent validity (Winstanley et al., 2006). However, when considering the broad definition of acting with less forethought, impulsivity has the potential to interfere with the effortful process of emotion regulation by accelerating emotional expression (Peckham & Johnson, 2018; Gross, 2013).

Impulsivity is characterized by difficulties with evaluation of consequences (Winstanley et al., 2006). If emotion regulation is motivated by instrumental goals, individuals who are highly impulsive may have challenges with selecting and implementing appropriate emotion regulation strategies, which in turn, can have negative consequences (e.g., difficulty maintaining social relationships; Graziano et al., 2011). Individuals with higher emotion dysregulation have been found to report higher levels of impulsivity ( $N = 194$ , ages 18-29 years; Schreiber et al., 2012). As such, self-reported impulsivity, behavioural impulsivity, and impulsivity in the context of ADHD symptomology were explored in the present research.

### **The Present Research: Study 1 and Study 2**

The present research was comprised of two studies with four primary objectives. The first objective was to test if eye-tracking could be used to directly measure attentional deployment

when viewing video clips. The existing literature has used indirect measurements of attentional deployment via various mood ratings prior to and after a task where participants were trained to use attentional deployment (e.g., Golding & Gross, 2010). Eye-tracking still images has been used as a measure of attentional deployment in conjunction with cognitive reappraisal and expressive suppression tasks (Bebko et al., 2011). Lohani and Isaacowitz's (2014) study used eye-tracking while participants viewed video clips from motion pictures, but the eye-tracking output was only used as a manipulation check.

The present research built on the methodology used in the Lohani and Isaacowitz's (2014) study by using eye-tracking video clips from a motion picture to measure attentional deployment. However, during programming, the areas of interest were developed using a free-form tool rather than pre-determined ellipses to allow for a more precise and realistic delineation of where the participant was looking. Pupil dilation was used as a measure of emotional arousal.

The second objective of this project was to further explore the relations between attentional deployment and other emotion regulation strategies; specifically, cognitive reappraisal and expressive suppression. Based on neuroimaging data, researchers have hypothesized that attention may be the mechanism behind the process of cognitive reappraisal (van Reekum et al., 2007). Measuring attentional deployment when viewing video clips may provide more insight into this process.

The third objective of this project was to explore how attention deficit hyperactivity disorder symptomology (ADHD; inattention, hyperactivity, and level of impulsivity) related to different emotion regulation strategies. This was because ADHD, a disorder of attention and greater impulsivity, a symptom of ADHD, have been related to poorer emotion regulation in both clinical and nonclinical populations (APA, 2013; Peckham & Johnson, 2018).



The fourth, and final, objective of this project was to use a simple visual stimulus that is emotionally evocative but does not have human auditory or visual cues (i.e., a film of moving shapes). Comparing visual attention when viewing a video with people to a video of moving shapes can provide insight into whether the interpretation of a stimulus evokes the same type of regulation, regardless of the presence of human emotional cues.

These four objectives were measured in two studies. The studies were identical in that participants' demographic variables, attention deficit hyperactivity disorder symptomology, behavioural impulsivity, self-reported impulsivity, and emotion regulation were measured. The two studies differed in the eye-tracking tasks on which attentional deployment was measured. The first study used video clips from a movie showing people in realistic situations ("The Perks of Being a Wallflower"; Halfon et al., 2012) and the second study used a film of moving shapes (the Social Attribution Task; Heider & Simmel, 1944).

### **Study 1 Research Questions and Hypotheses**

**Research Question 1 (RQ1): Can eye-tracking video clips be used as a measure of attentional deployment?** The first objective of the present research was to determine if eye-tracking video clips could be used as a direct measure of attentional deployment. Eye-tracking has been used to measure attentional deployment with still images and has been used as a manipulation check for video clips. Video clips of different emotional valences are included because depending on the emotion evoked, the goals for regulating emotion may change (Tamir, 2011). For example, individuals tend to use more attentional deployment when trying to reduce negative emotions than positive emotions (Gross, 2013). Attentional deployment, when measured through eye-tracking, has been defined as people looking away from negatively emotionally evocative regions toward neutral regions of a stimulus (Bebko et al., 2011).

Emotionally evocative regions in this film were defined as the people in the scene and neutral stimuli were backgrounds (Lohani & Isaacowitz, 2014). In the present study, attentional deployment is quantified as a ratio of the total percent of time looking at people divided by the total percent of time looking at backgrounds. Therefore, when comparing attentional deployment between video clips, greater attentional deployment toward backgrounds and away from people is indicated by a smaller numerical value of attentional deployment (since the denominator of the ratio would be larger). To identify whether the video clips rated as evoking different emotions demonstrated different arousal levels, average pupil diameter was measured (Just et al., 2003). Pupil diameter is a nonspecific measure of arousal and therefore no predictions were made around directionality of arousal (Lee et al., 2012).

***Hypothesis 1a.*** Greater attentional deployment (i.e., spending more time looking at backgrounds and less time looking at people), is expected when viewing the negative video clip than when viewing the positive clip. Greater attentional deployment is expected when viewing the negative video clip than when viewing the ambiguous video clip (relatively equally rated as positive and negative), and greater attentional deployment is expected when viewing the ambiguous video clip than when viewing the positive video clip.

***Hypothesis 1b.*** Average pupil diameter is expected to differ between the three types of video clips: positive, negative, and ambiguous (relatively equally rated as positive and negative).

**Research Question 2 (RQ2): Does attentional deployment predict self-reported cognitive reappraisal and expressive suppression when viewing people in realistic situations?** The second objective was to examine how attentional deployment might relate to other emotion regulation strategies. It has been argued that attentional deployment may be a mechanism behind the process of cognitive reappraisal and expressive suppression (van Reekum

et al., 2007). This hypothesis was tested for attentional deployment during video clips of people in realistic situations that evoked positive emotions, negative emotions, and were ambiguously evocative (relatively equally rated as positive and negative). Gender has been related to emotion regulation strategy preference (McRae et al., 2008). As well, previous exposure to the film has the potential to influence what the participant visually attends to. Therefore, both gender and previous exposure to the film used in the current study were considered as variables to control.

***Hypothesis 2a.*** After controlling for gender and previous exposure to the film, attentional deployment during positive, negative, and ambiguous (relatively equally rated as positive and negative) video clips will predict cognitive reappraisal.

***Hypothesis 2b.*** After controlling for gender and previous exposure to the film, attentional deployment during positive, negative, and ambiguous (relatively equally rated as positive and negative) video clips will predict expressive suppression.

**Research Question 3 (RQ3): Is there a difference in the use of emotion regulation strategies (cognitive reappraisal, expressive suppression, and attentional deployment when viewing clips of people) when comparing individuals with greater ADHD symptoms to individuals with less ADHD symptoms?** The third objective was to examine the relations between emotion regulation strategies and symptoms associated with ADHD. Individuals with more ADHD symptoms and greater impulsivity demonstrate poorer emotion regulation (APA, 2013; Peckham & Johnson, 2018). Cognitive reappraisal is the most adaptive of the emotion regulation strategies and has been related to improvements in psychological adjustment (Nezlek & Kuppens, 2008). The use of cognitive reappraisal has been associated with overall healthier social functioning behaviours, affect, and well-being than the use of expressive suppression (Cutuli, 2014). Therefore, in individuals who struggle with emotion regulation, it is expected that

cognitive reappraisal will be less used as compared to individuals with better emotion regulation. Expressive suppression is characterized by the inhibition of an emotion which would be difficult for an individual with high impulsivity (Gross, 2013; Peckham & Johnson, 2018). Attentional deployment has also been noted to result in poorer outcomes in the long term, but not in the short-term (Thiruchaselvam et al., 2011). Therefore, it is expected that individuals reporting high ADHD symptomology will demonstrate greater attentional deployment toward backgrounds (neutral stimuli) as compared to individuals reporting lower levels of ADHD symptomology.

***Hypothesis 3a.*** Compared to individuals with less ADHD symptoms, individuals with greater ADHD symptoms will demonstrate less use of cognitive reappraisal.

***Hypothesis 3b.*** Compared to individuals with less ADHD symptoms, individuals with greater ADHD symptoms will demonstrate less use of expressive suppression.

***Hypothesis 3c.*** Compared to individuals with less ADHD symptoms, individuals with greater ADHD symptoms will demonstrate greater attentional deployment (i.e., looking more at backgrounds and less at characters) when viewing a video clip of people that evoke positive emotions.

***Hypothesis 3d.*** Compared to individuals with less ADHD symptoms, individuals with greater ADHD symptoms will demonstrate greater attentional deployment when viewing a video clip of people that evoke negative emotions.

***Hypothesis 3e.*** Compared to individuals with less ADHD symptoms, individuals with greater ADHD symptoms will demonstrate greater attentional deployment when viewing a video clip of people that is ambiguous (approximately equally rated as positive and negative).

## Study 2 Research Questions and Hypotheses

### **Research Question 4 (RQ4): Does attentional deployment predict self-reported cognitive reappraisal and expressive suppression when viewing a video of moving shapes?**

This research question addresses the second objective of the current research project, which is whether attentional deployment relates to other emotion regulation strategies. The film of moving shapes is often interpreted as negative and therefore may evoke attentional deployment. Therefore, attentional deployment when viewing moving shapes will be tested as a predictor of the emotion regulation strategies, cognitive reappraisal and expressive suppression (van Reekum et al., 2007). Again, gender and previous exposure to the film were controlled (Mcrae et al., 2008).

*Hypothesis 4a.* After controlling for gender and previous exposure to the film, attentional deployment during the film of moving shapes will predict cognitive reappraisal.

*Hypothesis 4b.* After controlling for gender and previous exposure to the film, attentional deployment during the film of moving shapes will predict expressive suppression.

### **Research Question 5 (RQ5): Is there a difference in the use of emotion regulation strategies (cognitive reappraisal, expressive suppression, and attentional deployment when viewing a film of moving shapes) when comparing individuals with greater ADHD symptoms to individuals with less ADHD symptoms?**

This research question addresses the third objective: to examine the relations between emotion regulation strategies and symptoms associated with ADHD, similar to RQ3. Individuals with more ADHD symptoms will demonstrate poorer emotion regulation, characterized as less use of cognitive reappraisal, less use of expressive suppression, and greater use of attentional deployment, even when viewing a film of moving shapes (Peckham & Johnson, 2018).

*Hypothesis 5a.* Compared to individuals with less ADHD symptoms, individuals with greater ADHD symptoms will demonstrate less use of cognitive reappraisal.

*Hypothesis 5b.* Compared to individuals with less ADHD symptoms, individuals with greater ADHD symptoms will demonstrate less use of expressive suppression.

*Hypothesis 5c.* Compared to individuals with less ADHD symptoms, individuals with greater ADHD symptoms will demonstrate greater attentional deployment (i.e., looking more at backgrounds and less at characters) when viewing a video of moving shapes.

### **Comparing Study 1 and Study 2**

**Research Question 6 (RQ6). Does attentional deployment differ when viewing video clips of human stimuli as compared to viewing a video of moving shapes?** The fourth objective of the current research was to examine attentional deployment using different stimuli by comparing the viewing of video clips of people to a video of moving shapes. The video of moving shapes was designed to elicit an interpretation of a negative social interaction (Klin, 2000). Individuals use attentional deployment strategies more often when trying to reduce negative feelings (Gross, 2013;). Therefore, participants were predicted to utilize greater attentional deployment to reduce negative feelings when watching the video of moving shapes than when viewing realistic video clips of people that evoked positive emotions.

There would be greater attentional deployment when viewing realistic video clips of people that evoked negative emotions than when viewing the video of moving shapes because the video clips of people have additional complex human cues that contribute to the emotional appraisal (e.g., body language, context, vocal quality, conversation providing situational context) that can influence the intensity of the emotion evoked and the emotion regulation process; this would particularly be the case when complex human cues are compared to a simple stimuli that

requires inferential interpretation (Gobbini, Koralek, Bryan, Montgomery, & Haxby, 2007; Gross, 2013). Similarly, the ambiguous clip would evoke greater attentional deployment than the film of moving shapes.

***Hypothesis 6a.*** Attentional deployment will be greater when viewing the film of moving shapes, often interpreted as negative, than when viewing a video clip of people that evokes positive emotions.

***Hypothesis 6b.*** Attentional deployment will be less when viewing the film of moving shapes than when viewing a video clip of people that evokes negative emotions.

***Hypothesis 6c.*** Attentional deployment will be less when viewing the film of moving shapes than when viewing a video clip of people that is ambiguously evocative (relatively equally rated as positive and negative).

A summary of all of the hypotheses for both studies is presented in Table 1. The specific details regarding the studies' participants, measures, and procedures are presented in the Method section to follow.

Table 1  
*Summary of Hypotheses for Both Studies*

<b>Objective</b>	<b>Study</b>	<b>Hypotheses</b>
1	1	<p><b>1a.</b> Attentional deployment will be greatest* for the negative clip, second greatest for the ambiguously evocative** clip and smallest for the positive clip</p> <p><b>1b.</b> Average pupil diameter will differ when comparing the positive, negative, and ambiguously evocative video clips.</p>
2	1	<p><b>2a.</b> Attentional deployment will predict cognitive reappraisal, over and above gender and previous exposure to the stimulus.</p> <p><b>2b.</b> Attentional deployment will predict expressive suppression, over and above gender and previous exposure to the stimulus.</p>
3	1	<p><b>3.</b> ADHD symptoms and impulsivity will cluster into high and low groups.</p> <p><b>3a.</b> The higher ADHD symptoms group will demonstrate less cognitive reappraisal than the lower group.</p> <p><b>3b.</b> The higher ADHD symptoms group will demonstrate less expressive suppression than the lower group.</p> <p><b>3c.</b> The higher ADHD symptoms group will demonstrate greater attentional deployment than the lower group when viewing a positive video clip.</p> <p><b>3d.</b> The higher ADHD symptoms group will demonstrate greater attentional deployment than the lower group when viewing a negative video clip.</p> <p><b>3e.</b> The higher ADHD symptoms group will demonstrate greater attentional deployment than the lower group when viewing an ambiguously evocative video clip.</p>
2	2	<p><b>4a.</b> Attentional deployment will predict cognitive reappraisal, over and above gender and previous exposure to the stimulus.</p> <p><b>4b.</b> Attentional deployment will predict expressive suppression, over and above gender and previous exposure to the stimulus.</p>
3	2	<p><b>5.</b> ADHD symptoms and impulsivity will cluster into high and low groups.</p> <p><b>5a.</b> The higher ADHD symptoms group will demonstrate less cognitive reappraisal than the lower group.</p> <p><b>5b.</b> The higher ADHD symptoms group will demonstrate less expressive suppression than the lower group.</p> <p><b>5c.</b> The higher ADHD symptoms group will demonstrate greater attentional deployment than the lower group when viewing a film of moving shapes.</p>



- 4            1&2            **6a.** Attentional deployment will be greater for the HS-SAT than the positive clip.  
**6b.** Attentional deployment will be greater for the negative clip than the HS-SAT.  
**6c.** Attentional deployment will be greater for the ambiguously evocative clip than the HS-SAT.

---

Note. HS-SAT = Heider and Simmel's (1944) Social Attribution Task

\*Greater attentional deployment means participants will look more at backgrounds than characters.

\*\*The ambiguously evocative clip had relatively equal ratings of evoking positive and negative emotions.

## CHAPTER 2

### METHOD

#### Participants

Undergraduate students were recruited from the participant pool at a medium-sized, ethnically diverse, Canadian university (student population greater than 15 000) in a multicultural city (population 200 000). Participants required normal or corrected-to-normal vision to participate in this study and received 2 points toward their grades for completion of the study. A power analysis estimated that a minimum of 77 participants should be recruited for linear multiple regression (effect size is .15; power of .80; Faul, Erdfelder, Lang, & Buchner, 2007).

One hundred undergraduate students participated in Study 1 (82% women; 18% men;  $M_{100} = 23.11$  years,  $SD = 7.60$ ). Of the sample, 49% had a corrected-to-normal visual impairment, 4% had a formal diagnosis of ADHD, but 35% met minimum screening criteria for ADHD on the ASRSv1.1. Nine of the participants did not have eye-tracking data due to difficulties with calibration.

One hundred one undergraduate students participated in Study 2 (77.22% women; 22.77% men;  $M_{101} = 21.21$  years,  $SD = 5.55$ ). Of the sample, 48% had a corrected-to-normal visual impairment, 2% had a formal diagnosis of ADHD, but 36% met minimum screening criteria for ADHD on the ASRSv1.1. Two of the participants did not have eye-tracking data due to difficulties with calibration. Participants from Study 1 were restricted from participating in Study 2. Further demographic information for both studies can be found in Appendix B.

## Measures and Apparatus

The measures and apparatus for both studies were identical with the exception of the eye-tracking task. Participants' demographic background (Bardone-Cone et al., 2016), ADHD symptomology (Kessler et al., 2005), self-reported levels of impulsivity (Stanford et al., 2009), behavioural impulsivity (Dougherty et al., 2002), and emotion regulation (Gross & John, 2003) were measured in both studies. In Study 1, participants were shown five video clips from the motion picture "The Perks of Being a Wallflower" (Halfon et al., 2012), while calibrated to an eye tracker (SR Research Ltd, 2016). In Study 2, participants were shown a video of moving shapes (Heider & Simmel, 1944), while calibrated to an eye tracker (SR Research Ltd, 2016). A detailed list of constructs, measures, study variables, and units of measurements can be found in Table 2. Information about the permissions obtained to use the measures can be found in Appendix C.

**Demographic variables.** The demographic form (Bardone-Cone et al., 2016; Appendix D) includes information about gender, visual and hearing impairment, and diagnoses of mental health disorder (such as ADHD). Gender can relate to preferred emotion regulation strategy, visual and hearing impairment could impact participation in the study since participants are presented with visual tasks and auditory instructions, and mental health diagnoses were collected to identify the number of participants formally diagnosed with ADHD (APA, 2013; Nolen-Hoeksema & Aldao, 2011).

**ADHD symptomology.** The Adult ADHD Self-Report Scale (ASRS-v1.1) is an 18-item questionnaire developed by the World Health Organization. It is a screening tool for Attention Deficit Hyperactivity Disorder (ADHD; Kessler, et al., 2005). Participants are asked to report on

Table 2

*List of Measures, Study Variables, and Units of Measurement for Study 1 and 2*

<u>Study</u>	<u>Construct</u>	<u>Measure</u>	<u>Study Variables</u>	<u>Unit of Measurement</u>
1&2	ADHD Symptoms	Adult ADHD Self-Report Scale (ASRS-v1.1; Kessler et al., 2005)	Total Symptom Score Minimum score for further query	Range of scores is 18-90 Minimum 4/6 highlighted scores
1&2	Impulsivity	Barratt Impulsiveness Scale-11 <sup>th</sup> Edition (BIS-11; Barratt, Stanford et al., 2009)	Total Impulsivity Score	Range of scores is 30-120 Clinically significant cutoff $\geq 72$
		Immediate Memory Task (Dougherty, Mash, Mathias, 2002)	Discrepancy Score	Range of scores is 0.5-1
1	Emotional Arousal	Eye Tracker Output (SR Research Ltd., 2016)	Pupil diameter per fixation duration	Average diameter
1	Emotional Valence	Eye Tracker Output (SR Research Ltd., 2016) during viewing of clips from "The Perks of Being a Wallflower" (Halfon et al., 2012)	Subjective Emotional Valence	Positive or Negative
1&2	Emotion Regulation	Emotion Regulation Questionnaire (Gross & John, 2003)	Cognitive reappraisal Expressive suppression	Range of scores is 6-24 Range of scores is 4-16

1	Eye Tracker Output (SR Research Ltd., 2016) during viewing of clips from “The Perks of Being a Wallflower” (Halfon et al., 2012)	Attentional deployment <ul style="list-style-type: none"> <li>• AD+</li> <li>• AD-</li> <li>• ADa</li> </ul>	Ratio of % time looking at people vs. % time looking at background <ul style="list-style-type: none"> <li>• For “birthday” scene (+), “slap” scene (-), and “classroom” scene (a)</li> </ul>
2	Eye Tracker Output (SR Research Ltd., 2016) during viewing of Heider-Simmel (1944) film of moving shapes moving.	Attentional deployment <ul style="list-style-type: none"> <li>• AD<sub>HS-SAT</sub></li> </ul>	Ratio of % time looking at character shapes vs. % time looking at background

---

*Note.* ADHD = attention deficit hyperactivity disorder; AD+ = attentional deployment during positive video clip; AD- = attentional deployment during negative video clip; ADa = attentional deployment during ambiguously evocative video clip (equal positive and negative ratings); AD<sub>HS-SAT</sub> = attentional deployment while viewing the Social Attribution Task

items that measure their capacity for attention, hyperactivity, and impulsivity, as well as the impairment that they experience in daily living due to deficits in these areas. Each question is quantified on a 5-point Likert scale, where 1 is never and 5 is very often. The ASRS-v1.1 has a presence or absence screening criterion for the first six questions and if the participant endorses a minimum for four of the six questions, further investigating for an ADHD diagnosis should take place. This screener is reportedly 100% accurate for capturing individuals with ADHD, but its breadth can also lead to false-positives (Kessler et al., 2005). The internal consistency of the ASRS-v1.1 was good in both Study 1 (Cronbach's  $\alpha = .84$ ) and Study 2 (Cronbach's  $\alpha = .82$ ).

**Self-reported impulsivity.** The Barratt Impulsiveness Scale (BIS-11) is a 30-item questionnaire that is the most widely used measurement of impulsivity (Patton, Stanford, & Barratt, 1995; Stanford et al., 2009). Participants report on how they would act/think in different scenarios. Each question is quantified on a 4-point Likert scale, where 1 is rarely/never and 4 is almost always/always. The scale measures three subtraits: cognitive impulsiveness (making quick decisions), motor impulsiveness (action without thought), and non-planning impulsiveness (lack of forethought; Stanford et al., 2009). Test-retest reliability of the BIS-11 after one month was Spearman's  $\rho = .83$  and had an internal consistency of  $\alpha = .83$  (Reid, Cyders, Moghaddam, & Fong, 2013). The internal consistency of the BIS-11 was fair in Study 1 (Cronbach's  $\alpha = .77$ ) and Study 2 (Cronbach's  $\alpha = .78$ ). The BIS-11 demonstrates high convergent validity with other self-report measures of impulsivity including Eysenck's Impulsiveness Scale (Patton & Stanford, 1995; Stanford et al., 2009). Higher scores on the BIS-11 indicate higher levels of impulsivity; with 72 as the clinical cutoff for "high impulsivity" (Stanford et al., 2009).

**Behavioural impulsivity.** The Immediate Memory Task (IMT) is a modified Continuous Performance Task that is completed on a computer. It is designed to measure attention, memory,

and impulsivity. During this task, a five-digit numbers appears one at a time in the centre of the screen at a rate of 500ms. Participants are to click the mouse when they see a number that is identical to the previous number but refrain from clicking if the number differs. This task outputs a ratio of commission errors to correct detections, also known as a discriminability value, which is meant to be an indicator of impulsive responding (Dougherty et al., 2000). The IMT has poor convergent validity with the BIS-11,  $\alpha = .57$  (IMT; Cyders & Coskunpinar, 2012; Portney & Watkins, 2000).

**Emotion regulation (cognitive reappraisal and expressive suppression).** The Emotion Regulation Questionnaire (ERQ) is a 10-item measure of two emotion regulation strategies: cognitive reappraisal and expressive suppression (Gross & John, 2003). Participants report on their emotional experience and emotional expression through questions about how they control their emotions. Each question is quantified on a 7-point Likert scale, for which 1 is strongly disagree and 4 is strongly agree. Cognitive reappraisal is represented by six items and expressive suppression by four (Gross & John, 2003). Test-retest reliability of the ERQ after three months is  $\alpha = .69$  and internal consistency for reappraisal ranged from  $\alpha = .75-.82$ , while suppression ranged from  $\alpha = .68-.76$  (Gross & John, 2003). The internal consistency of the cognitive reappraisal subscale was good in Study 1 (*Cronbach's*  $\alpha = .83$ ) and Study 2 (*Cronbach's*  $\alpha = .85$ ). The internal consistency of expressive suppression subscale was poor in Study 1 (*Cronbach's*  $\alpha = .65$ ) and good in Study 2 (*Cronbach's*  $\alpha = .82$ ). This scale only has four items and removal of the lowest correlating item (“When I am feeling *positive* emotions, I am careful not to express them”) still resulted in poor internal consistency (*Cronbach's*  $\alpha = .68$ ). Results in Study 1 that use the expressive suppression subscale were interpreted with caution.

**Visual attention.** The Eyelink 1000 Plus is a desktop mount eye tracker that records and processes eye movements while the participant views a computer screen. The eye tracker uses an infrared light to illuminate the positioning of the pupil and cornea reflections for a precise estimate of the location of participants' visual focus (SR Research Ltd, 2016).

**Video stimuli of people (Study 1).** In Study 1, participants watched five short clips from the 2012 film adaptation of Stephen Chbosky's novel of the same name, "The Perks of Being a Wallflower" (Halfon et al., 2012). This movie was chosen because it features three protagonists involved in a variety of emotion-rich social situations. The scenes offer nonessential objects (e.g., couch, fireplace, books) in everyday settings including home and school. As well, the scenes do not have background music playing to cue the viewer about specific moods. The only music that is played during the video clips is in a scene that takes place during a dance. The clips range from 24-52 seconds each for a total of 2 minutes and 52 seconds. A custom eye tracking program was developed by the author of this dissertation and a post-doctoral psycholinguistics fellow with training in programming eye-tracking experiments and SR Research. The template of this program as well as areas of interest for the film were created per frame using SR Research Experiment Builder, a graphical program (Appendix E). Areas of Interest (AOIs) are targeted physical and temporal parameters outlined by the researcher that allow specific data extraction. Custom dynamic areas of interest were delineated for all people and backgrounds (e.g., the room) in the frame (Figure 1). In other words, a shape was drawn around each character and background in order for the eye-tracker to specifically output what the participant was looking at. Because "The Perks of Being a Wallflower" has people moving in every video clip, the areas of



**Figure 1.**

*Example of areas of interest for people and background.*

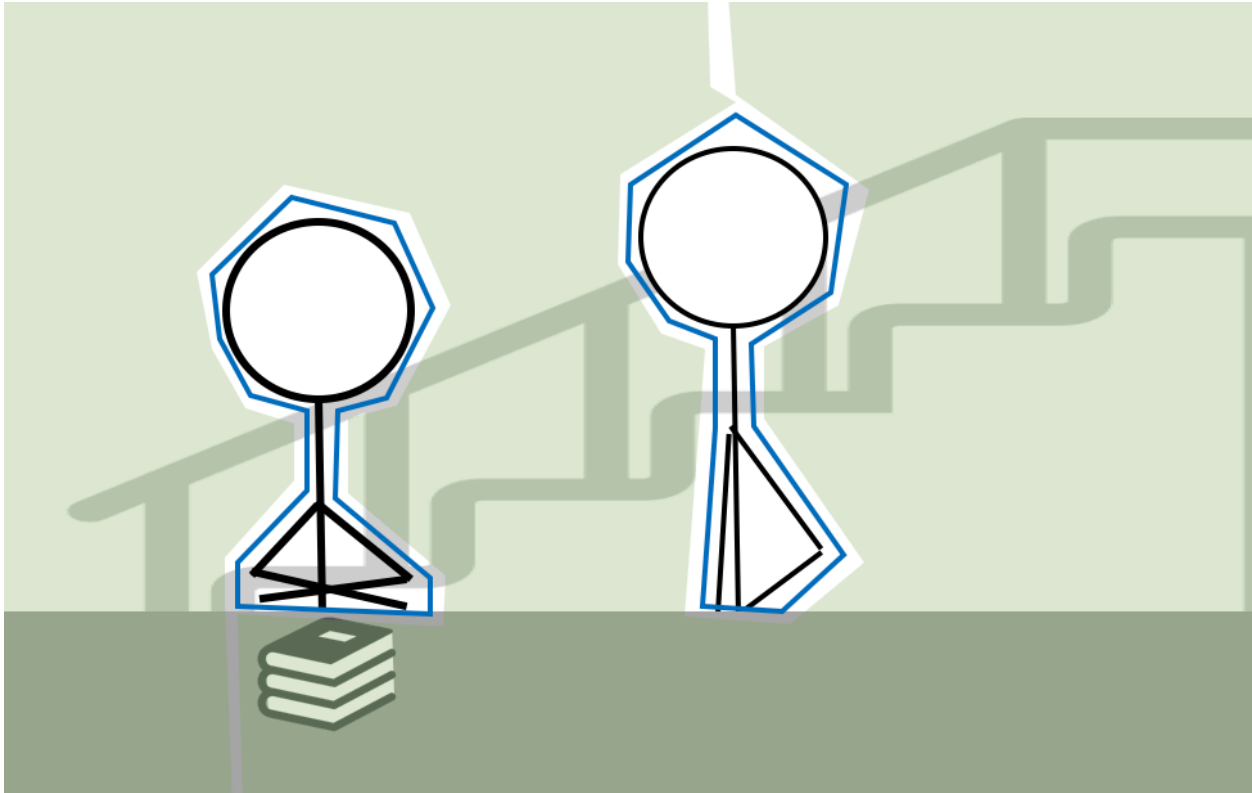

*Note.* The areas of interest indicating people is shown with a blue outline and the area of interest indicating the background is shown with a wash of green over it. This image is intended as a depiction of a screen shot from the copyrighted film clips to demonstrate how areas of interest were delineated.

**Figure 2.**

*Example image of precision when defining areas of interest frame by frame to capture movement.*

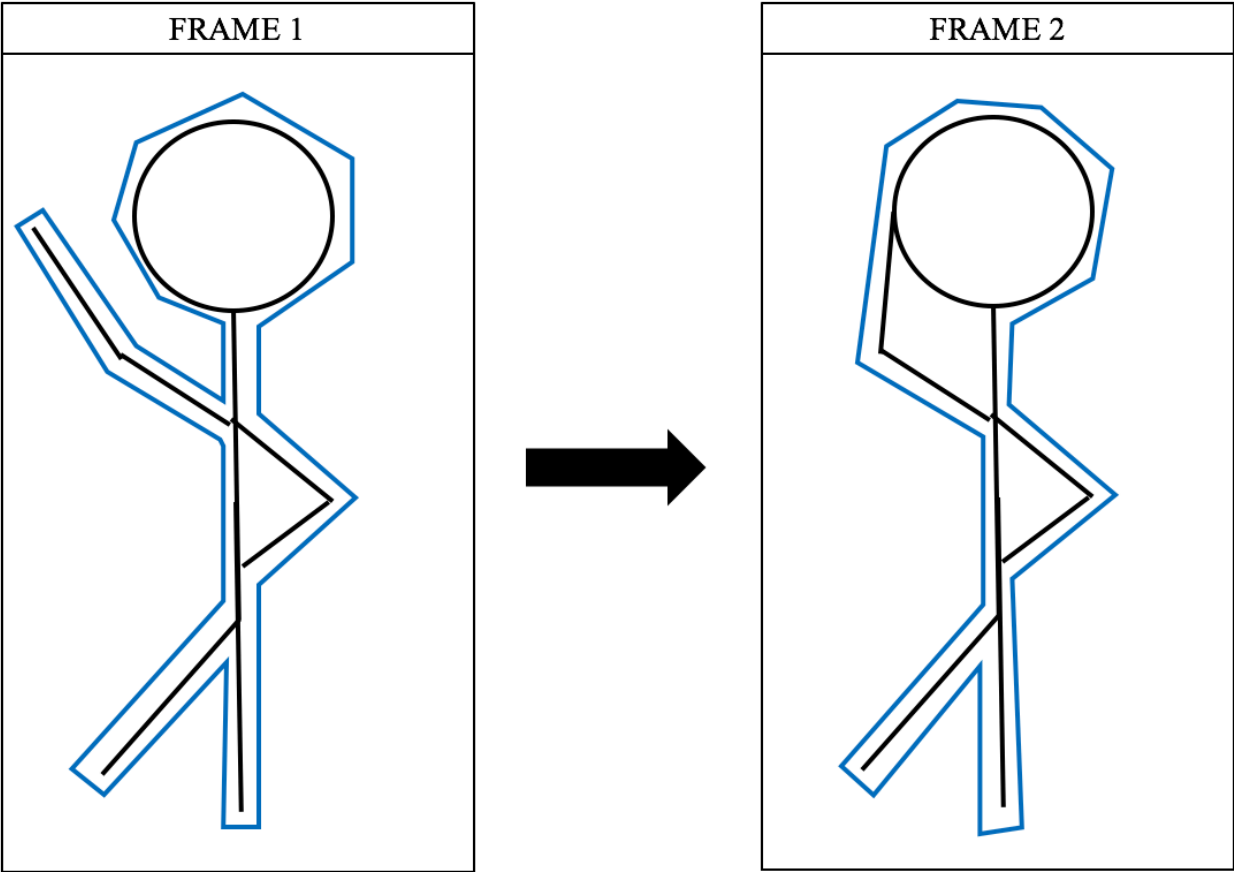

interest were drawn frame-by-frame by the researcher (4128 frames for the five clips combined<sup>1</sup>) for a precise reading of where the individual was looking (Figure 2). The areas of interest allow the eye tracking software to specifically report gaze direction (i.e., if a character or background being looked at) and duration of participants' focus (i.e., how much time is spent looking at different areas of interest; SR Research Ltd., 2016). In two of the scenes, the "classroom" scene and the "dance" scene, there are students that are out of focus in the background, these students are coded as "background" variables. Each video clip was separated by two seconds of a blank screen with a central fixation point (a white screen with a dot in the middle) to correct eye drift (SR Research Ltd., 2016). As well, programming allowed for participants to identify if they felt a positive emotion (right arrow key) or negative emotion (left arrow key) after viewing each clip. A file with the responses of positive or negative for each video clip was output for each participant. As well, for each participant, an area of interest file was extracted from their output, which had the values for percentage of fixation duration per character and background as well as pupil sizes from each video clip. There are three eye-tracking variables relevant to this project: the percentage of time that a person looked at each character and background, the pupil diameter during each fixation per video clip, and the identification of if a clip evoked a positive or negative emotion. The program was piloted on 10 people to ensure the appropriate data could be extracted. The method for measuring attentional deployment and pupil diameter follow.

*Attentional deployment during the Perks of Being a Wallflower.* Participants viewed five clips from the motion picture, "The Perks of Being a Wallflower". After each clip, participants identified if the video clip evoked positive emotions (right arrow key) or negative

---

<sup>1</sup> Areas of Interest files for the video clips developed for Study 1 and Study 2 are available from the researcher.

emotions (left arrow key). Of the five clips, two videos were primarily rated as positive, two had a relatively evenly split, and one video was rated as negative by all participants (Table 3).

Attentional deployment (AD) was determined by the sum of the percentage of time spent looking at the main characters divided by the sum of the percentage of time looking at the background. Therefore, more attentional deployment (i.e., looking more at backgrounds than characters) would be represented by a smaller numerical value for AD (since the denominator is greater). A larger numerical value of AD is representative of less attentional deployment (i.e., spending more time looking at people than backgrounds). Three video clips were selected to represent attentional deployment during a positive clip (AD+), a negative clip (AD-), and an ambiguously evocative clip (ADa).

The “birthday” scene is a video clip that was primarily rated as positive and shows a family reunion for the main character’s birthday. The clip displays the family members hugging and laughing before the main character blows out the candles on his birthday cake. This video was rated as positive by 89 out of 91 participants and is, therefore, considered a positive video clip. Since two people rated the “birthday” scene as negative, they were removed from all analyses. In the “slap” scene, the main character witnesses his sister and her boyfriend fighting before the boyfriend slaps the sister. All 91 participants rated this video as negative, therefore this video is used as a negative clip. In the “classroom” scene, one of the main characters is making fun of a teacher, making his peers laugh, and is then caught by that teacher. Forty-five participants rated this clip as positive and 46 participants rated the clip as negative, therefore, the “classroom” scene is considered an ambiguous video clip.

***Pupil diameter.*** Pupil diameter is a measurement of autonomic arousal and is defined by using the eye-tracker output called “CURRENT\_FIX\_PUPIL” found in the areas of interest file

Table 3

*Number of Participants who Rated Video Clips from “The Perks of Being a Wallflower” per Valence*

---

<u>Video Clip</u>	<u>Positive</u>	<u>Negative</u>
1. “Birthday”	89	2
2. “Cereal”	51	40
3. “Dance”	89	2
4. “Slap”	0	91
5. “Classroom”	45	46

---

*Note.*  $N = 91$

(SR Research Ltd, 2016). The minimum value is zero with no maximum value. This value is a measure of the pupil size in eye-tracker units during the current fixation. Pupil diameter was measured by average “CURRENT\_FIX\_PUPIL” per video clip. Pupil size and changes in diameter differ per person (Kloosterman et al., 2015). To account for this, the average pupil diameter was compared between the positive, negative, and ambiguously evocative video clips within subjects in Study 1 and pupil size was not compared between the two studies.

**Video stimulus of shapes (Study 2).** In Study 2, a custom eye-tracking program was developed by the researcher on SR Research Experiment Builder v2.1.140 for the Social Attribution Task (SAT), a film of moving shapes and piloted on 10 people (Heider & Simmel, 1944; Appendix F). This film was selected because it does not offer any human emotional cues but is often interpreted as a negative interaction between the shapes (Klin, 2000). Participants viewed the film clip twice and told the story aloud during the second viewing. Only the eye-tracking output from first viewing was measured. Custom areas of interest were delineated frame-by-frame by the researcher (2136 frames) for each of the shapes (small triangle, big triangle, and circle; Figure 3) and background from the first viewing of the SAT. For each participant, an area of interest file was extracted from their output, which had the values of percentage of fixation duration per character and background. These data were used to calculate attentional deployment. Data from the second viewing were not analyzed because they were beyond the scope of the current project.

**Attentional deployment during Heider and Simmel’s Social Attribution Task.**

Attentional deployment during the Social Attribution Task ( $AD_{HS-SAT}$ ) was determined by the average percentage of time spent looking at characters (big triangle, small triangle, and circle) divided by the percentage of time looking at backgrounds (“house”, blank background) per clip.

Figure 3.

*Still from the film of moving shapes showing the areas of interest for characters and background.*

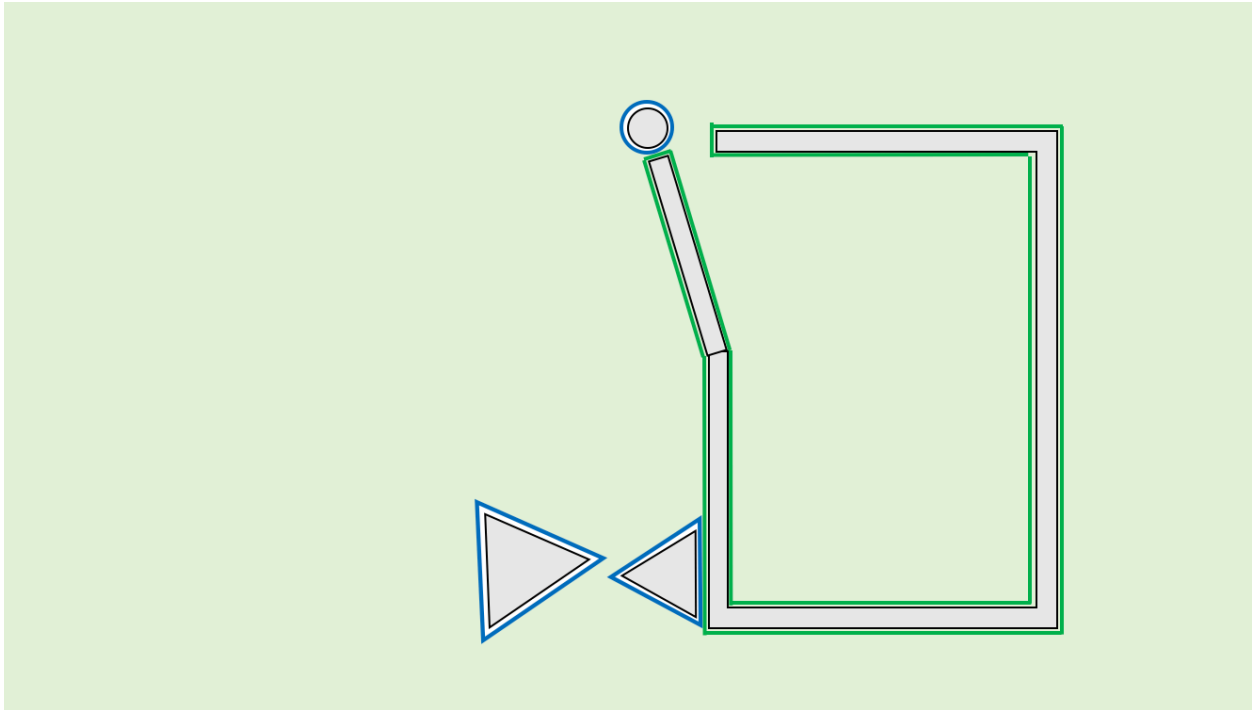

*Note.* The areas of interest indicating characters are shown with a blue outline and the areas of interest indicating the background is shown with a wash of green over it.

Therefore, greater attentional deployment (i.e., looking more at backgrounds than characters) would be represented by a smaller numerical value for AD, and less attentional deployment (i.e., looking more at characters than backgrounds) would be represented by a larger numerical value for AD.

### **General Procedure**

Undergraduate students from the University of Windsor were recruited from the University's Participant Pool and were invited into the lab for a one-hour testing session as approved by the University of Windsor Research Ethics Board. Participants completed informed consent and discussed the conditions of withdrawal before proceeding (Appendix G). Participants began the study by completing a standard demographic information form (Appendix D).

Participants were calibrated to the eye-tracker to ensure eye movements could be tracked with accuracy during the task. Calibration required participants to place their head on a chin rest while seated and for the right eye to look at nine focal test points on the test computer screen (SR Research Ltd., 2016). Once the calibration was completed, participants completed the eye-tracking task. After the eye-tracking task, participants identified if they had had any previous exposure to the video(s). Participants then received instructions and completed the *Immediate Memory Task* (Dougherty et al., 2002). Next, participants completed the *Adult ADHD Self-Report Scale* (Kessler et al., 2005), the *Emotion Regulation Questionnaire* (Gross & John, 2003), and the *Barratt Impulsiveness Scale – Eleventh Edition* (Stanford et al., 2009; three paper tests) in counterbalanced order. Finally, participants were debriefed on the study and received a letter of information with researcher contact information, details of the study, participants' right to withdraw, and a list of resources to address any potential feelings of distress or discomfort that



may have been experienced by participants (Appendices G and H). Participants were then awarded their points.

**Eye-tracking procedure for Study 1.** After being calibrated to the eye-tracker, the customized program began. Once the program started, participants received instructions on the task and on identifying whether they feel positive or negative, following the clip. They were shown an image of a smiling face (for which they were instructed to press the right arrow key) and then they were shown a frowning face (for which they were instructed to press the left arrow key). Once this task was completed, they received another instruction page that informed them to focus on the centre of the dot when the central fixation point appeared (a dot in the middle of a white screen) and to press the space bar to begin. When the space bar is pressed, the program prepares a randomized sequence of five clips from “The Perks of Being a Wallflower”. Participants identify if the clip is positive or negative only after it has finished playing. Pressing the right or left arrow key prompts the next clip to play. After the task was completed, the data were output using the customized areas of interest outlined for the task.

**Eye-tracking procedure for Study 2.** Similar to Study 1, after the calibration to the eye-tracker was completed, the customized program began. Once the program started, participants received instructions that they would be viewing a silent short-film clip twice and were asked to verbally tell the story of what is happening in the film during the second viewing, and to press the space bar to begin. Once participants pressed the space bar, they were shown the Heider and Simmel’s (1944) Social Attribution Task (SAT), a film of moving shapes twice. Each participant had a single Attentional Deployment ( $AD_{HS-SAT}$ ) score calculated for this task based on the first viewing of the SAT. Once the eye-tracking task was completed, participants were asked to label each “character” in the film (Appendix I). Fifty five percent of participants labelled the shapes

with a characterization (e.g., “bully”, “father”, “dog”, etc.) and 45% of participants labelled the shapes with shape names (e.g., “small circle”, “triangle”).

## CHAPTER 3

### RESULTS

An overview of hypotheses, variables, and analyses can be found in Table 4. There were no missing data for any of the measures in Study 1 or 2. Participants who could not be calibrated to the eye-tracker (nine participants in Study 1 and two participants in Study 2) were excluded from all analyses. As well, in Study 1, the two participants who rated the “birthday” scene as negative were excluded from all analyses. Preliminary analyses for Study 1 and 2 are presented, followed by results for Study 1, results for Study 2, and, finally, results comparing Study 1 and Study 2.

#### **Preliminary Analyses (Study 1 and 2)**

**Assumptions of repeated-measures ANOVA.** Repeated-measures ANOVAs were conducted to test hypotheses 1a and 1b. There were no significant outliers in the attentional deployment data. The assumptions of repeated-measures ANOVA include normality within groups and sphericity (e.g., the relationship between the pairs in the experimental conditions are approximately equal; Field, 2013). The variables were normally distributed (as demonstrated by skewness and kurtosis as well as the Shapiro-Wilk Test) for the positive video clip (AD+) and the negative video clip (AD-), but not for the ambiguous video clip (ADa; Table 5). AD- demonstrated a positive leptokurtic distribution (a kurtosis of 10.03), which is greater than 3 (a general cutoff for normality; Field, 2013). As well, the Shapiro-Wilk test indicated that AD- was not normally distributed ( $p < .01$ , when  $p$  should be greater than .05). As such, AD- was log-transformed, after which AD- demonstrated normal kurtosis (.41) and Shapiro-Wilk indicated a normal distribution ( $p = .18$ ; Field, 2013). AD+ and ADa were log-transformed in order to compare the data to AD- (Field, 2013). Attentional deployment violated

Table 4

*List of Hypotheses, Study Variables, Measures, and Analyses for Study 1 and 2*

Study	Hypothesis	Variable(s) 1	Variable(s) 2	Analysis
1	1a	<ul style="list-style-type: none"> <li>AD-</li> <li>AD+</li> <li>ADa</li> </ul>		One-way Repeated-Measures ANOVA
1	1b	<ul style="list-style-type: none"> <li>Avg pupil diameter negative video</li> <li>Avg pupil diameter positive video</li> <li>Avg pupil diameter ambiguous video</li> </ul>		One-way Repeated-Measures ANOVA
1	2a	AD+, AD-, ADa <ul style="list-style-type: none"> <li>Over and above gender, previous exposure to PBW</li> </ul>	Cognitive reappraisal	Hierarchical multiple regression analysis
1	2b	AD+, AD-, ADa <ul style="list-style-type: none"> <li>Over and above gender, previous exposure to PBW</li> </ul>	Expressive suppression	Hierarchical multiple regression analysis
1	3	ADHD symptomology	Impulsivity	Cluster Analysis
	3a	ADHD/Impulsivity	<ul style="list-style-type: none"> <li>Cognitive reappraisal</li> </ul>	MANOVA
	3b	Clusters	<ul style="list-style-type: none"> <li>Expressive Suppression</li> </ul>	
	3c		<ul style="list-style-type: none"> <li>AD+</li> </ul>	
	3d		<ul style="list-style-type: none"> <li>AD-</li> </ul>	
	3e		<ul style="list-style-type: none"> <li>ADa</li> </ul>	
2	4a	AD <sub>HS-SAT</sub> <ul style="list-style-type: none"> <li>Over and above gender, previous exposure to HS-SAT</li> </ul>	Cognitive reappraisal	Hierarchical multiple regression analysis

2	4b	AD <sub>HS-SAT</sub> <ul style="list-style-type: none"> <li>Over and above gender, previous exposure to HS-SAT</li> </ul>	Expressive suppression	Hierarchical multiple regression analysis
2	5	ADHD symptomology	Impulsivity	Cluster Analysis
2	5a 5b 5c	ADHD/Impulsivity Clusters	<ul style="list-style-type: none"> <li>Cognitive reappraisal</li> <li>Expressive Suppression</li> <li>AD<sub>HS-SAT</sub></li> </ul>	MANOVA
1&2	6	<ul style="list-style-type: none"> <li>AD-</li> <li>AD+</li> <li>ADa</li> </ul>	AD <sub>HS-SAT</sub>	Independent t-tests

---

*Note.* AD+ = attentional deployment for positive video clip; AD- = attentional deployment for negative video clip; ADa = attentional deployment for ambiguously evocative video clip; AD<sub>HS-SAT</sub> = attentional deployment while viewing Heider and Simmel's Social Attribution Task; ASRSv1.1 = Attention Deficit Hyperactivity Disorder Self-Report Scale (Kessler et al., 2005); BIS-11 = Barratt Impulsiveness Scale, Eleventh Edition (Stanford et al., 2009); ERQ = Emotion Regulation Questionnaire (Gross & John, 2003); PBW = The Perks of Being a Wallflower (Halfon et al., 2012); HS-SAT = Social Attribution Task (Heider & Simmel, 1944).

Table 5

*Descriptive Statistics (Including Mean, SD, Skewness, Kurtosis) for Study 1 Continuous Variables*

Variable	Mean	Standard Deviation	Range	Skewness	Kurtosis
AD+	7.69	3.57	1.17-20.62	1.28	2.17
AD-	5.13	6.59	0.04-37.93	2.72	10.03
ADa	4.31	1.83	0.71-9.60	0.32	-0.17
ASRS-v1.1	50.52	9.37	23.00-76.00	-0.22	0.15
BIS-11 Total	63.11	9.94	43.00-88.00	0.23	-0.50
IMT	0.84	0.06	0.67-0.99	-0.43	0.15
ERQ Cognitive Reappraisal	29.72	6.97	6.00-42.00	-0.49	0.95
ERQ Expressive Suppression	15.23	4.64	6.00-25.00	-0.28	-0.82
Average pupil diameter +	1535.55	520.36	506.02-3255.29	0.48	0.40
Average pupil diameter -	1642.46	539.15	623.97-3314.20	0.35	-0.03

*Note.*  $N = 89$ ; AD+ = Attentional deployment for positive clip; AD- = Attentional deployment for negative clip; ADa = attentional deployment for ambiguously evocative clip; ASRSv1.1 = Attention Deficit Hyperactivity Disorder Self-Report Scale (Kessler et al., 2005); BIS-11 = Barratt Impulsiveness Scale, Eleventh Edition (Stanford et al., 2009); ERQ = Emotion Regulation Questionnaire (Gross & John, 2003); IMT = Immediate Memory Task (Dougherty, 2002).

the assumption of sphericity ( $p < .01$ , where  $p$  should be greater than .05). The Greenhouse-Geisser correction was used to interpret the data because it adjusts the degrees of freedom to provide a conservative estimate of the  $F$ -ratio ( $\epsilon = 0.67$ ; Field, 2013; Greenhouse and Geisser, 1959; Huynh & Feldt, 1976). Since AD+ is used in five analyses from this study (to test *hypotheses 1a, 2a, 2b, 3c and 6a*), a Bonferroni correction was made so the  $p$ -value was adjusted to .01 for tests using AD+ (Field, 2013). The same  $p$ -value adjustment was made for AD- (to test *hypotheses 1a, 2a, 2b, 3d and 6b*) and ADa (to test *hypotheses 1a, 2a, 2b, 3e and 6c*) which are also used in five analyses. Descriptive statistics for the continuous variables used in Study 1 can be found in Table 5. The assumptions of repeated measures ANOVA were also tested for average pupil diameter. There were no significant outliers in the pupil diameter data. Average pupil diameter for each type of video clip had a normal distribution as measured by skewness, kurtosis, and Shapiro-Wilk's test. However, sphericity was violated ( $p < .01$ ). As such, the Greenhouse-Geisser correction was used for interpretation of the results ( $\epsilon = 0.69$ ; Field, 2013; Greenhouse and Geisser, 1959; Huynh & Feldt, 1976).

**Assumptions of hierarchical multiple regression analyses.** Hypotheses 2a and 2b (Study 1) as well as hypotheses 4a and 4b (Study 2) were tested with four hierarchical multiple regression analyses. A correlation matrix comparing the proposed independent variables in Study 1 can be found in Table 6 and the correlation matrix for Study 2 can be found in Table 7. The assumptions of multiple regression include absence of outliers and influential observations, absence of multicollinearity (the extent to which the independent variables correlate with each other), linearity when comparing standardized residuals and predicted values, homoscedasticity of errors, and independence of errors (Keith, 2014). In both studies, there were

Table 6

Correlation Table for All Variables in Study 1

	Age	Gender	Watched PBW	Read PBW	ERQ-CR	ERQ-ES	ASRS Total	BIS-11 Total	BIS-11 Cog	BIS-11 Motor	BIS-11 NP	IMT	AD b-day (+)	AD slap (-)	AD class (a)	
Age	-															
Gender	-.14	-														
Watched PBW	.26*	-.16	-													
Read PBW	.20*	-.15	.31**	-												
ERQ - CR	.21*	.03	.07	.01	-											
ERQ - ES	-.03	-.03	-.03	-.06	-.14	-										
ASRS	-.20*	.06	-.05	.11	-.21	.16	-									
Total																
BIS-11 Total	-.25*	.15	-.09	.14	-.32**	.14	.53**	-								
BIS-11 Cog	-.30**	.09	-.02	.12	.19	.77**	.77**	.73**	-							
BIS-11 Motor	-.14	.12	-.14	.13	.10	.27**	.27**	.81**	.43**	-						
BIS-11 NP	-.14	.14	-.06	.08	.05	.21*	.21*	.77**	.29**	.46**	-					
IMT	-.15	-.06	-.02	.04	-.12	-.12	-.12	.04	-.09	.07	.11	-				
AD b-day (+)	-.06	-.06	.05	.09	-.29**	.04	.07	.11	.14	.08	.02	.18	-			
AD slap (-)	.17	-.04	.03	.07	-.08	-.03	.04	-.11	.01	-.14	-.13	-.05	.12	-		
AD class (a)	.07	-.17	-.08	.18	-.16	-.28**	-.09	-.09	-.14	-.01	-.05	.18	.21	.13	-	

Note. \*p > .05 (2-tailed); \*\*p > .01 (2-tailed); N = 91; Gender: Males = 1; Females = 2; PBW = The Perks of Being a Wallflower (Halfon et al., 2012); Watched PBW: Yes = 1, No = 2; Read PBW: Yes = 1, No = 2; ERQ = Emotion Regulation Questionnaire (Gross & John, 2003); CR = Cognitive reappraisal; ES = Expressive Suppression; ASRS Total = Total Score on the ADHD Self-Report Scale (Kessler et al., 2005); BIS-11 = Barratt Impulsiveness Scale, Eleventh Edition; Cog = Cognitive Impulsiveness; Motor = Motor Impulsiveness; NP = Non-planning impulsiveness; IMT = Immediate Memory Task (Dougherty, 2002)



Table 7

Correlation Table for All Variables in Study 2

	Age	Gender	Watched HS-SAT	ERQ-CR	ERQ-ES	ERQ Total	ASRS Total	BIS-11 Total	BIS-11 Cog	BIS-11 Motor	BiS-11 NP	IMT	AD <sub>HS-SAT</sub>
Age	-												
Gender	.10	-											
Watched HS-SAT	-.06	-.16	-										
ERQ - CR	.15	.05	.03	-									
ERQ - ES	-.23	-.26	.34*	-.18	-								
ASRS Total	-.010	.44*	-.37*	.01	-.07	-							
BIS-11 Total	.02	.35*	-.27	-.04	-.12	.67**	-						
BIS-11 Cog	-.15	.26	-.30	-.06	.02	.71**	.77**	-					
BIS-11 Motor	.09	.38*	-.13	.14	-.19	.43**	.81**	.42**	-				
Motor													
BIS-11 NP	.10	.19	-.20	-.17	-.011	.46**	.80**	.39**	.52**	-			
IMT	-.24	-.33*	-.04	-.03	.23	-.08	-.15	-.01	-.18	-.18	-		
AD <sub>HS-SAT</sub>	-.07	.19	.03	.05	.02	-.08	.08	.71.07	.23	-.10	-.15	-	

Note. \* $p > .05$  (2-tailed); \*\* $p > .01$  (2-tailed);  $N = 91$ ; Gender: Males = 1, Females = 2; HS-SAT = Heider and Simmel's Social Attribution Task; Watched HS-SAT: Yes = 1, No = 2; ERQ = Emotion Regulation Questionnaire (Gross & John, 2003); CR = Cognitive reappraisal; ES = Expressive Suppression; ASRS Total = Total Score on the ADHD Self-Report Scale (Kessler et al., 2005); BIS-11 = Barratt Impulsiveness Scale, Eleventh Edition; Cog = Cognitive Impulsiveness; Motor = Motor Impulsiveness; NP = Non-planning impulsiveness; IMT = Immediate Memory Task; Dougherty, 2002;  $\log AD_{HS-SAT}$  = log transformation of average attentional deployment while viewing Heider and Simmel's Social Attribution Task.

no significant outliers. Tolerance was greater than .10 and the variance inflation factor was less than 10 for all independent variables (suggesting that multicollinearity was not an issue; Field, 2013). A review of the scatterplots of standardized residuals to predicted values shows a random display of points falling within an absolute value of 2 (Field, 2013). Since the distributions of the scatterplots were not curves, linearity was assumed. The residual plot demonstrated a random pattern therefore the assumption of homoscedasticity was maintained. Finally, a relatively random display of points in the scatterplots of the studentized residuals against predicted values provided evidence of independence of errors (Field, 2013).

In Study 2, since  $AD_{HS-SAT}$  is used in six analyses from this study (to test *hypotheses 4a, 4b, 5c and 6a-c*), a Bonferroni correction was made so the p-value was adjusted to .01 for tests using  $AD_{HS-SAT}$ . Descriptive statistics for Study 2 can be found in Table 8.

**Cluster analyses and assumptions of MANOVA.** Hypotheses 3 (Study 1) and 5 (Study 2) were tested by clustering ADHD symptom variables and then comparing the resultant clusters on different emotion regulation strategies via MANOVAs. In both Study 1 and 2, the correlation matrix showed that the ASRSv1.1 was highly correlated to the BIS-11, the IMT was not correlated with either test, and the three subscales of the BIS-11 were highly correlated (Table 6; Table 7). As such, the total value of the BIS-11, a self-report measure of impulsivity, was included in a cluster analysis with the ASRSv1.1, a measure of ADHD symptoms, and the IMT, a behavioural measure of impulsivity, was excluded from analyses.

**Cluster analysis for Study 1.** Attention Deficit Hyperactivity Disorder symptoms (ASRSv1.1) and level of impulsivity (BIS-11) were used as predictor variables in a two-step cluster analysis, which allows for grouping without a pre-determined number of clusters. Both

Table 8

*Descriptive Statistics (Including Mean, SD, Skewness, Kurtosis) for Study 2 Continuous Variables*

Variable	Mean	Standard Deviation	Range	Skewness	Kurtosis
AD <sub>HS-SAT</sub>	4.08	1.53	1.10-8.06	0.47	-0.25
ASRS-v1.1	50.02	9.00	31.00-73.00	0.32	-0.20
BIS-11 Total	64.80	9.40	42.00-95.00	0.52	0.24
IMT	0.83	0.07	0.53-0.94	-0.92	1.88
ERQ Cognitive Reappraisal	28.46	6.97	7.00-41.00	-0.86	1.07
ERQ Expressive Suppression	15.12	5.52	4.00-27.00	-0.23	-0.50

*Note.*  $N = 99$ ; AD<sub>HS-SAT</sub> = Attentional deployment while viewing the Social Attribution Task; ASRSv1.1 = Attention Deficit Hyperactivity Disorder Self-Report Scale (Kessler et al., 2005); BIS-11 = Barratt Impulsiveness Scale, Eleventh Edition (Stanford et al., 2009); ERQ = Emotion Regulation Questionnaire (Gross & John, 2003); IMT = Immediate Memory Task (Dougherty, 2002).

studies formed a high and low ADHD symptoms group. As such, each cluster was labelled by study number and whether they were high or low (e.g., Cluster 1-Hi indicates the cluster is from Study 1 and was higher in ADHD symptoms). In Study 1, the overall cluster quality, or goodness of fit, was good (.60), with predictor importance (weight of the predictor in cluster formation) as follows: ADHD symptoms (1.00) and impulsivity (.91). Two clusters formed: Cluster 1-Hi (higher ADHD symptomology [ $M = 56.98$ ] and higher impulsivity [ $M = 69.75$ ];  $N = 51$ ) and Cluster 1-Lo (lower ADHD symptomology [ $M = 43.65$ ] and lower impulsivity [ $M = 56.06$ ];  $N = 48$ ). As well, 61% of participants in Cluster 1-Hi and 8% of participants in Cluster 1-Lo passed minimum screening criteria for ADHD according to the ASRSv1.1. A MANOVA was conducted to test *hypotheses 3a-3e* using these clusters.

***Cluster analysis for Study 2.*** A two-step cluster analysis was conducted using ADHD symptoms (ASRSv1.1) and level of impulsivity (BIS-11) as predictor variables in Study 2. The overall cluster quality is rated as good (.60), with predictor importance as follows: ADHD symptoms (1.00) and impulsivity (.91). Two clusters formed: Cluster 2-Hi (higher ADHD symptomology [ $M = 59.76$ ] and higher impulsivity [ $M = 74.67$ ];  $N = 68$ ) and Cluster 2-Lo (lower ADHD symptomology [ $M = 45.29$ ] and lower impulsivity [ $M = 60.01$ ];  $N = 33$ ). As well, 73% of participants in Cluster 2-Hi and 18% of participants in Cluster 2-Lo passed minimum screening criteria for ADHD according to the ASRSv1.1. A MANOVA was conducted to test *hypotheses 5a-5c* using these clusters.

***Assumptions of MANOVA.*** The assumptions of MANOVA include independence of observations, random sampling, multivariate normality, and homogeneity of covariance matrices (Field, 2013). There is an independence of observations between the groups. Normal distributions (as demonstrated by skewness and kurtosis as well as the Shapiro-Wilk Test) was

found for the dependent variables. There was an adequate sample size, no outliers were found with boxplots or Mahalanobis distance. Homogeneity of variance-covariance matrices was demonstrated using Box's M and the  $p$ -values were greater than .05 in both Study 1 ( $p = .32$ ) and Study 2 ( $p = .66$ ; Field, 2013).

## Study 1 Results

**Hypothesis 1a.** A one-way repeated-measures ANOVA was conducted to test if attentional deployment differed between the positive, negative, and ambiguously evocative (relatively equal positive and negative ratings) video clips. Using the Greenhouse-Geisser correction, the repeated-measures ANOVA showed a significant main effect of video clip valence on attentional deployment  $F(1.34, 111.27) = 84.26, p < .01$  (Field, 2013). Bonferroni post hoc tests showed that AD+ ( $M = 1.07, SD = 0.02$ ) was significantly greater (95% CI = [0.50, 0.80];  $p < .01$ ) than AD- ( $M = 0.42, SD = 0.06$ ), AD+ was significantly greater (95% CI = [0.31, 0.55];  $p < .01$ ) than ADa ( $M = 0.60, SD = 0.02$ ), and ADa was significantly greater (95% CI = [0.03, 0.32];  $p = .01$ ) than AD-. Therefore, the numerical value of AD+ was statistically greater than ADa, which was statistically greater than AD-, which means the greatest attentional deployment occurred during the negative clip, the second greatest attentional deployment occurred during the ambiguously evocative clip and the least attentional deployment occurred during the positive clip. Therefore, *hypothesis 1a* was supported.

A post-hoc analysis was conducted for the ambiguous clip comparing attentional deployment in participants who rated the video clip as positive to participants who rated the video clip as negative to identify if these groups significantly differed. Assumptions of normality and homogeneity of variance were met (Levene's test:  $p = .62$ ). An independent t-test showed no significant difference in attentional deployment between those that rated the ambiguously

evocative clip as positive ( $M = 0.58$ ,  $SD = 0.22$ ) and those that rated it as negative ( $M = 0.59$ ,  $SD = 0.22$ );  $t(87) = -0.31$ , 95% CI =  $[-0.11, 0.08]$ ,  $p = .76$ .

**Hypothesis 1b.** A one-way repeated-measures ANOVA was conducted to test if pupil diameter differed between the positive, negative, and ambiguously evocative video clips. A Greenhouse-Geisser correction demonstrated a significant main effect of video clip valence on attentional deployment  $F(1.39, 119.09) = 28.98$ ,  $p < .01$ . Bonferroni post-hoc tests showed that pupil diameter for the positive video clip ( $M = 1522.92$ ,  $SD = 519.06$ ) was significantly less (95% CI =  $[1.47, 220.85]$ ;  $p = .05$ ) than pupil diameter for the negative video clip ( $M = 1634.08$ ,  $SD = 538.85$ ), pupil diameter for the positive video clip was significantly greater (95% CI =  $[71.09, 275.13]$ ;  $p < .01$ ) than pupil diameter for the ambiguously evocative video clip ( $M = 1349.81$ ,  $SD = 469.24$ ), and pupil diameter for the negative video clip was significantly greater (95% CI =  $[230.47, 338.07]$ ;  $p < .01$ ) than pupil diameter for the ambiguously evocative video clip. Therefore, pupil diameter for the negative video clip was statistically greater than the positive video clip, which was statistically greater than the ambiguous video clip and *hypothesis 1b* was supported.

A post-hoc analysis was conducted for the ambiguously evocative video clip comparing pupil diameter in participants who rated the video clip as positive to participants who rated the video clip as negative to identify if these groups significantly differed. Assumptions of normality and homogeneity of variance were met (Levene's test:  $p = .37$ ). An independent t-test showed no significant difference in pupil diameter between those that rated the ambiguous clips as positive ( $M = 1381.05$ ,  $SD = 436.24$ ) and those that rated it as negative ( $M = 1327.55$ ,  $SD = 498.49$ );  $t(87) = 0.54$ , 95% CI =  $[-143.74, 250.73]$ ,  $p = .59$ .

**Hypothesis 2a.** Two hierarchical multiple regression analyses (MRAs) measured whether attentional deployment (AD+, AD-, and ADa) significantly predicted participants' cognitive reappraisal when controlling for gender and previous exposure to the stimulus. As shown in Table 9, results indicated that the model was not significant  $F(2,81) = 1.08, p = 3.47$ . Gender and previous exposure to the film did not predict cognitive reappraisal. The second model showed that attentional deployment and was not a significant predictor of cognitive reappraisal, with the Bonferroni adjustment,  $F(5,78) = 2.53, p = .04$ . Spending more time looking at people than backgrounds during the positive clip (AD+) predicted less cognitive reappraisal ( $b_{AD+} = -11.11, t(78) = -2.84, p < .01$ ). AD- ( $b_{AD-} = 2.05, t(78) = 1.48, p = .14$ ) and ADa ( $b_{ADa} = -2.60, t(78) = -0.69, p = .49$ ) did not significantly predict cognitive reappraisal. Therefore, hypothesis 2a was supported for AD+.

**Hypothesis 2b.** A hierarchical MRA tested whether attentional deployment predicted participants' expressive suppression. In the first step gender and previous exposure to the film "The Perks of Being a Wallflower", and in the second step AD+, AD-, and ADa were tested. Results of the regression (Table 10) indicated that the covariate model was not significant  $F(2,81) = 0.01, p = .99$ ; gender and previous exposure to the film did not predict expressive suppression. As well, attentional deployment was not a significant predictor of expressive suppression,  $F(5,78) = 1.45, p = .22$ . AD+ and AD- did not predict expressive suppression ( $b_{AD+} = 0.07, t(85) = 0.69, p = .52$ ;  $b_{AD-} = -.03, t(85) = -.03, p = .47$ ). However, greater attentional deployment toward backgrounds during an ambiguously evocative clip (smaller numerical value of ADa) predicted greater expressive suppression ( $b_{ADa} = -6.75, t(85) = -2.66, p = .01$ ). Therefore, hypothesis 2b was supported for the ambiguous clip.

Table 9

*Hierarchical Multiple Regression Analysis Predicting Cognitive Reappraisal from Attentional Deployment in Study 1*

Variable	R <sup>2</sup>	ΔR <sup>2</sup>	Unstandardized Coefficients		Standardized Coefficients	Part Corr. <sup>2</sup>	95% B CI	Tolerance	VIF
			B	SE B	B				
Step 1	0.17	0.03							
Gender			0.01	1.97	.00	<.01	[-3.91 - 3.92]	.90	1.11
Watched PBW			2.32	1.55	.16	.02	[-0.77 - 5.41]	.92	1.08
Step 2	0.37	0.14							
logAD+			-11.11	3.92	-.31*	.09	[-18.91 - -3.32]	.95	1.06
logAD-			2.05	1.38	-.16	.02	[-0.70 - 4.79]	.95	1.05
log ADa			-2.60	3.75	-.08	<.01	[-10.07 - 4.87]	.88	1.14

*Note.*  $N = 89$ ; \* $p = .01$ ; PBW = The Perks of Being a Wallflower (Halfon et al., 2012); logAD+ = log-transformation of attentional deployment for positive clip; logAD- = log-transformation of attentional deployment for negative clip; logADa = log-transformation of attentional deployment for the ambiguously evocative clip.



Table 10

*Hierarchical Multiple Regression Analysis Predicting Expressive Suppression from Attentional Deployment when Viewing Videos Rated as Relatively Negative in Study 1*

Variable	R <sup>2</sup>	ΔR <sup>2</sup>	Unstandardized Coefficients		Standardized Coefficients	Part Corr. <sup>2</sup>	95% B CI	Tolerance	VIF
			B	SE B	B				
Step 1	0.01	<0.01							
Gender			-.77	1.33	-.07	<.01	[-3.43 – 1.87]	.90	1.11
Watched PBW			-.63	1.05	-.07	<.01	[-2.72 – 1.46]	.92	1.09
Step 2	0.29	0.09							
logAD+			1.71	2.65	.07	<.01	[-3.57 – 6.99]	.95	1.06
logAD-			-.03	0.94	<.01	<.01	[-1.89 – 1.84]	.95	1.05
log ADa			-6.75	2.54	-.31*	.08	[-11.80 – -1.70]	.89	1.14

*Note.*  $N = 89$ ; PBW = The Perks of Being a Wallflower (Halfon et al., 2012); logAD+ = log-transformation of attentional deployment for positive clip; logAD- = log-transformation of attentional deployment for negative clip; logADa = log-transformation of attentional deployment for the ambiguously evocative clip.

**Hypotheses 3a-3e.** A MANOVA was conducted to test if individuals with greater ADHD symptoms demonstrate less cognitive reappraisal (*hypothesis 3a*), less expressive suppression (*hypothesis 3b*), and more attentional deployment (*hypothesis 3c-e*) than individuals with less ADHD symptoms. Using the two clusters formed in the preliminary analyses, a MANOVA was conducted to compare Cluster 1-Hi to Cluster 1-Lo on the different types of emotion regulation.

Overall, the differences between Cluster 1-Hi and Cluster 1-Lo was not statistically significant based on types of emotion regulation,  $F(5, 78) = 1.28, p = .28$ ; *Wilk's  $\Lambda$*  = 0.92, *partial  $\eta^2$*  = .08. Since there are multiple dependent measures, a statistical model reduction was conducted to obtain power (Cohen, 1992; Tabachnick & Fidell, 2001). The most nonsignificant variables were trimmed, beginning with AD- because it had the highest p-value ( $p = .96$ ), which resulted in the following model:  $F(4, 80) = 1.70, p = .16$ ; *Wilk's  $\Lambda$*  = 0.92, *partial  $\eta^2$*  = .08. Next, AD+ was trimmed because it had the highest p-value ( $p = .68$ ) in the new model, which resulted in a statistically significant MANOVA model:  $F(3, 84) = 2.88, p = .04$ ; *Wilk's  $\Lambda$*  = 0.91, *partial  $\eta^2$*  = .09. The univariate F-test showed that cognitive reappraisal was significantly greater in the low ADHD symptom group (Cluster 1-Lo) when compared to the high ADHD symptom group (Cluster 1-Hi;  $F(1, 86) = 5.06, p = .03$ ; *partial  $\eta^2$*  = .06). The two clusters did not significantly differ for expressive suppression ( $p = .23$ ), nor attentional deployment during the ambiguous video clip ( $p = .13$ ). Therefore, hypothesis 3a was supported and hypotheses 3b, 3c, 3d, and 3e were not supported.

## **Study 2 Results**

**Hypothesis 4a.** A hierarchical MRA tested if attentional deployment, when watching a video clip of moving shapes (AD<sub>HS-SAT</sub>), predicted cognitive reappraisal. In the first step gender and previous exposure to the Social Attribution Task were included, and in the second step

$AD_{HS-SAT}$  was tested. A correlation matrix can be found in Table 7 and results of the analysis can be found in Table 11. The first ( $F(2, 96) = 0.43, p = .65$ ) and second ( $F(3, 95) = 0.30, p = .82$ ) models were not significant. Gender and prior exposure to the stimulus did not predict cognitive reappraisal levels and attentional deployment while viewing a video of moving shapes did not significantly predict cognitive reappraisal ( $b_{AD,HS-SAT} = -0.04, t(93) = -0.34, p = .73$ ). As such, *hypothesis 4a* was not supported.

**Hypothesis 4b.** A hierarchical MRA tested if attentional deployment, when watching video clips of moving shapes ( $AD_{HS-SAT}$ ), predicted expressive suppression. In the first step, gender and previous exposure to the Social Attribution Task were included and in the second step  $AD_{HS-SAT}$  was tested. Results of the analysis can be found in Table 12. The first ( $F(2, 96) = 1.91, p = .15$ ) and second ( $F(3, 95) = 1.27, p = .29$ ) models were not significant. Gender and prior exposure to the stimulus did not predict expressive suppression levels and attentional deployment while viewing a video of moving shapes did not significantly predict cognitive reappraisal ( $b_{AD,HS-SAT} < -0.01, t(93) = -0.08, p = .94$ ). As such, *hypothesis 4b* was not supported.

**Hypotheses 5a-5c.** A MANOVA was conducted to test if individuals with greater ADHD symptoms demonstrate less cognitive reappraisal (*hypothesis 5a*), less expressive suppression (*hypothesis 5b*), and more attentional deployment ( $AD_{HS-SAT}$ ; *hypothesis 5c*) than individuals with less ADHD symptoms. Using the two clusters formed in the preliminary analyses, a MANOVA was conducted to compare Cluster 2-Hi to Cluster 2-Lo on the different types of emotion regulation. Overall, the differences between Cluster 2-Hi and Cluster 2-Lo was not statistically significant based on types of emotion regulation,  $F(3, 95) = 1.14, p = .33$ ; *Wilk's A* = 0.97, partial  $\eta^2 = .04$ . A statistical model reduction was not conducted because the number

Table 11

*Hierarchical Multiple Regression Analysis Predicting Cognitive Reappraisal from Attentional Deployment in Study 2*

Variable	R <sup>2</sup>	$\Delta R^2$	Unstandardized Coefficients		Standardized Coefficients	Part Corr. <sup>2</sup>	95% B CI	Tolerance	VIF
			B	SE B	B				
Step 1	0.09	0.01							
Gender			1.36	1.76	.08	<.01	[-1.83 - 5.33]	.85	1.18
Watched HS-SAT			-0.77	2.62	-.03	<.01	[-6.38 - 4.12]	.98	1.02
Step 2	0.10	0.01							
logAD <sub>HS-SAT</sub>			0.96	4.24	.02	<.01	[-1.13 - 0.80]	.93	1.07

Note. N = 98; HS-SAT = Social Attribution Task (Heider & Simmel, 1944); AD<sub>HS-SAT</sub> = attentional deployment while viewing the Social Attribution Task.

Table 12

*Hierarchical Multiple Regression Analysis Predicting Expressive Suppression from Attentional Deployment in Study 2*

Variable	R <sup>2</sup>	$\Delta R^2$	Unstandardized Coefficients		Standardized Coefficients	Part Corr. <sup>2</sup>	95% B CI	Tolerance	VIF
			B	SE B	B				
Step 1	.20	.04							
Gender			-2.50	1.37	-.19	.03	-5.16 - 0.45	.90	1.18
Watched HS-SAT			-0.50	2.04	.03	<.01	-3.62 - 4.60	.98	1.02
Step 2	.20	.04							
logAD <sub>HS-SAT</sub>			-0.50	3.30	-.02	<.01	-0.79 - 0.73	.93	1.07

Note. N = 98; HS-SAT = Social Attribution Task (Heider & Simmel, 1944); AD<sub>HS-SAT</sub> = attentional deployment while viewing SAT.

of dependent measures were fewer in Study 2 and because the most non-significant variables were two of the three variables (expressive suppression:  $p = .85$  and  $AD_{HS-SAT}$ :  $p = .86$  compared to cognitive reappraisal:  $p = .07$ ; Cohen, 1992; Tabachnick & Fidell, 2001).

### **Results Comparing Study 1 and Study 2**

A comparison of the descriptive statistics from Study 1 and Study 2 can be found in Table 13. Preliminary analyses for the independent t-tests include a test of normality and homogeneity of variance. The data were normally distributed (as demonstrated by skewness and kurtosis as well as the Shapiro-Wilk Test) and homogeneity of variance was demonstrated for the positive clip (Levene's test:  $p = .39$ ) and the ambiguously evocative clip (Levene's test:  $p = .11$ ) but not the negative clip (Levene's test:  $p = .01$ ; Field, 2013). Therefore, the Welch-Satterthwaite correction will be used to interpret attentional deployment for the negative clip (Brybaert, 2011).

**Hypothesis 6a-c.** Independent t-tests were conducted to test if attentional deployment when viewing video clips of people that were positive (*hypothesis 6a*), negative (*hypothesis 6b*), or ambiguously evocative (*hypothesis 6c*) significantly differed from attentional deployment when viewing a video of moving shapes. Participants demonstrated less attentional deployment when viewing the positive clip in Study 1 ( $M = 1.06$ ,  $SD = 0.20$ );  $t(186) = 18.24$ , 95% CI = [0.44, 0.54],  $p = .01$  than when viewing the Social Attribution Task (SAT) in Study 2 ( $M = 0.58$ ,  $SD = 0.17$ ). Participants demonstrated greater attentional deployment toward backgrounds when viewing the negative clip in Study 1 ( $M = 0.42$ ,  $SD = 0.54$ ) than when viewing the SAT in Study 2 ( $M = 0.58$ ,  $SD = 0.17$ );  $t(104.07) = -2.60$ , 95% CI = [-0.28 - -0.04],  $p = .01$  (equal variance not assumed). Finally, participants did not significantly differ in attentional deployment when comparing the ambiguously evocative clip in Study 1 ( $M = 0.59$ ,  $SD = 0.22$ ) to the SAT in

Table 13

*Descriptive Statistics (Including Mean, SD, and range) for Study 1 and 2 Continuous Variables*

Variable	Study 1*			Study 2**		
	Mean	Standard Deviation	Range	Mean	Standard Deviation	Range
AD+	7.69	3.57	1.17-20.62	-	-	-
AD-	5.13	6.59	0.04-37.93	-	-	-
ADa	4.31	1.83	0.71-9.60			
AD <sub>HS-SAT</sub>	-	-	-	4.08	1.53	1.10-8.06
ASRS-v1.1	50.52	9.37	23.00-76.00	50.02	9.00	31.00-73.00
BIS-11 Total	63.11	9.94	43.00-88.00	64.80	9.40	42.00-95.00
IMT	0.84	0.06	0.67-0.99	0.83	0.07	0.53-0.94
ERQ Cognitive Reappraisal	29.72	6.97	6.00-42.00	28.46	6.97	7.00-41.00
ERQ Expressive Suppression	15.23	4.64	6.00-25.00	15.12	5.52	4.00-27.00

*Note.* AD+ = attentional deployment during the positive video clip; AD- = attentional deployment during the negative video clip; ADa = attentional deployment during the ambiguously evocative clip (relatively equal positive and negative rating); AD<sub>HS-SAT</sub> = attentional deployment when viewing the Social Attribution Tasks; ASRSv1.1 = Attention Deficit Hyperactivity Disorder Self-Report Scale (Kessler et al., 2005); BIS-11 = Barratt Impulsiveness Scale, Eleventh Edition (Stanford et al., 2009); ERQ = Emotion Regulation Questionnaire (Gross & John, 2003); IMT = Immediate Memory Task (Dougherty et al., 2002).

\**N* = 89

\*\* *N* = 99

Study 2 ( $M = 0.58$ ,  $SD = 0.17$ );  $t(187) = 0.33$ , 95% CI = [-0.05 – 0.07],  $p = .74$ . Therefore, *hypotheses 6a and 6b* were supported, but *hypothesis 6c* was not supported.

**Post-hoc analyses comparing results for hypothesis 3a to hypothesis 5a.** Hypotheses 3a and 5a test if individuals with greater ADHD symptoms and greater impulsivity would demonstrate poorer cognitive reappraisal. A significant difference in the use of cognitive reappraisal was found between Cluster 1-Hi (higher ADHD symptoms and higher impulsivity) and Cluster 1-Lo (lower ADHD symptoms and lower impulsivity) in Study 1 but not between Cluster 2-Hi and Cluster 2-Lo in Study 2. Therefore, four independent t-tests comparing self-reported ADHD symptoms (ASRSv1.1) and impulsivity (BIS-11) were conducted to identify if there was a significant difference between the groups in each study. Cluster 1Lo was compared to Cluster 2-Lo on ADHD symptoms (ASRSv1.1) and impulsivity (BIS-11) using two independent t-tests. As well, Cluster 1Hi was compared to Cluster 2-Hi on ADHD symptoms and impulsivity using two independent t-tests.

Results of the post-hoc analyses showed no significant difference ( $p = .29$ ) between participants' self-reported ADHD symptoms for Cluster 1-Hi ( $M_{ADHDsx} = 56.98$ ,  $SD = 0.88$ ) and Cluster 2-Hi Study 2 ( $M_{ADHDsx} = 59.26$ ,  $SD = 0.99$ ). There was also no significant difference ( $p = .98$ ) between participants' self-reported ADHD symptoms for Cluster 1-Lo ( $M_{ADHDsx} = 43.65$ ,  $SD = 0.99$ ) and Cluster 2-Lo ( $M_{ADHDsx} = 45.07$ ,  $SD = 0.76$ ).

However, results showed a significant difference ( $p = .01$ ) between participants' self-reported impulsivity (BIS-11) for Cluster 1-Hi ( $M_{impulsivity} = 69.74$ ,  $SD = 1.18$ ) and Cluster 2-Hi ( $M_{impulsivity} = 74.67$ ,  $SD = 1.98$ ). There was also a significant difference ( $p = .01$ ) between participants' self-reported impulsivity for Cluster 1-Lo ( $M_{impulsivity} = 56.06$ ,  $SD = 0.82$ ) and



Cluster 2-Lo ( $M_{impulsivity} = 60.01$ ,  $SD = 1.12$ ). Therefore, participants in Study 1 endorsed significantly lower levels of impulsivity than participants in Study 2.

A summary of hypotheses and results can be found in Table 14.

Table 14

*Summary of Hypotheses and Results for Both Studies*

<b>Study</b>	<b>Hypotheses</b>	<b>Hypotheses Supported?</b>
1	<i>1a.</i> Attentional deployment will be greatest* for the negative clip, second greatest for the ambiguously evocative** clip and smallest for the positive clip	✓
	<i>1b.</i> Average pupil diameter will differ when comparing the positive, negative, and ambiguously evocative video clips.	✓
1	<i>2a.</i> Attentional deployment will predict cognitive reappraisal, over and above gender and previous exposure to the stimulus.	✓ for AD+
	<i>2b.</i> Attentional deployment will predict expressive suppression, over and above gender and previous exposure to the stimulus.	✓ for ADa
1	<i>3.</i> ADHD symptoms and impulsivity will cluster into high and low groups.	
	<i>3a.</i> The higher ADHD symptoms group will demonstrate less cognitive reappraisal than the lower group.***	✓
	<i>3b.</i> The higher ADHD symptoms group will demonstrate less expressive suppression than the lower group.	x
	<i>3c.</i> The higher ADHD symptoms group will demonstrate greater attentional deployment than the lower group when viewing a positive video clip.	x
	<i>3d.</i> The higher ADHD symptoms group will demonstrate greater attentional deployment than the lower group when viewing a negative video clip.	x
	<i>3e.</i> The higher ADHD symptoms group will demonstrate greater attentional deployment than the lower group when viewing an ambiguously evocative video clip.	x
2	<i>4a.</i> Attentional deployment will predict cognitive reappraisal, over and above gender and previous exposure to the stimulus.	x
	<i>4b.</i> Attentional deployment will predict expressive suppression, over and above gender and previous exposure to the stimulus.	x

2	<p><b>5.</b> ADHD symptoms and impulsivity will cluster into high and low groups.</p> <p><b>5a.</b> The higher ADHD symptoms group will demonstrate less cognitive reappraisal than the lower group.***</p> <p><b>5b.</b> The higher ADHD symptoms group will demonstrate less expressive suppression than the lower group.</p> <p><b>5c.</b> The higher ADHD symptoms group will demonstrate greater attentional deployment than the lower group when viewing a film of moving shapes.</p>	<p>x</p> <p>x</p> <p>x</p>
1&2	<p><b>6a.</b> Attentional deployment will be greater* for the HS-SAT than the positive clip.</p> <p><b>6b.</b> Attentional deployment will be greater for the negative clip than the HS-SAT.</p> <p><b>6c.</b> Attentional deployment will be greater for the ambiguously evocative clip** than the HS-SAT.</p>	<p>✓</p> <p>✓</p> <p>x</p>

Note. HS-SAT = Heider and Simmel's (1944) Social Attribution Task

\*Greater attentional deployment means participants will look more at backgrounds than characters.

\*\*The ambiguously evocative clip had relatively equal ratings of evoking positive and negative emotions.

\*\*\* Post-hoc analyses were run to identify why these results differed; self-reported impulsivity was found to significantly lower in both of the ADHD/impulsivity clusters in Study 1 when compared to both clusters in Study 2;

## CHAPTER 4

### DISCUSSION

This was the first research project to operationalize attentional deployment as a ratio that could be compared between video types and that used video clips as a direct measure of visual attentional deployment. Strengths of this research include the breadth of areas that attentional deployment was studied in; including comparison to other emotion regulation strategies (i.e., cognitive reappraisal and expressive suppression), comparison between high and low ADHD symptom groups, and investigating how appraisal relate to the attentional deployment process.

The primary objectives of the present research were to use eye-tracking as a direct measure of attentional deployment, to examine the relation between attentional deployment and other emotion regulation strategies, to identify how emotion regulation differs by ADHD symptomology, and to explore attentional deployment when viewing a subjectively negatively evocative film of moving shapes. Gross' process model of emotion regulation, that posits that attentional deployment, cognitive reappraisal, and expressive suppression are internal methods of changing the experience and expression of emotions, serves as the theoretical foundation for studying these objectives. There is no standardized method of measuring attentional deployment (redirecting attention away from the evocative stimuli to regulate emotion). Therefore, the current research aimed to use eye-tracking methodology to better understand attentional deployment as an emotion regulation strategy.

#### **Objective 1: Eye-tracking as a measure of attentional deployment**

Attentional deployment is the redirection of attention to change the experience of an emotion (Bargh & Williams, 2007). In previous research, the method of using eye-tracking as a measure of attentional deployment had been used while participants viewed still images but not

video clips, though video clips have been used as a manipulation check to ensure participants were looking where they were instructed to during an attentional deployment task (Bebko et al., 2011; Lohani & Isaacowitz, 2014; Wirth et al, 2018). The present research used eye-tracking while participants viewed realistic video clips of people that evoked positive and negative emotions, as well as a video clip that was ambiguously evocative (relatively equal positive and negative) to measure attentional deployment. The “slap” scene was selected because all participants rated it as evoking negative emotions, the “birthday” scene was selected because all participants (except for two that were removed from analyses) rated it as evoking positive emotions, and the “classroom” scene was selected to represent an ambiguously evocative video clip because an approximately equal number of participants rated it as positive compared to those who rated it as negative.

Based on previous eye-tracking research on attentional deployment, emotionally evocative areas of the video clips were identified as the people or characters in the scene and the backgrounds were identified as neutral stimuli (Bebko et al., 2011; Lohani & Isaacowitz, 2014). This design allowed for a broader range of visual stimuli to be considered emotionally evocative. It should be noted that detailed areas of interest were developed with precision, frame-by-frame, since precision has the potential to influence relevant eye-tracking output. Detailed areas of interest allowed for more specific information about what is drawing the visual attention to be output (e.g., unintended background information was not included in the evocative areas of interest, which is generally what happens when using broader shapes like ellipses are used; Wass, Forssman, & Leppänen, 2014). However, this process is extremely time consuming and impractical, but will likely become easier to do as eye-tracking technology advances. At the present time, to build on this project, the same video clips or a video clip where the individual

does not move as frequently in the various frames could be used. Dynamic movements were desirable in this project in order to improve the accuracy of viewing patterns.

By measuring evocative stimuli as the total characters, different aspects of what visual components were evocative have been captured (e.g., in the “slap” scene, the emotionally evocative aspect could have been the aggressor’s facial expression, the victim’s facial expression, the victim’s body language, the witness’ reaction, etc). The benefit is that the emotionally evocative stimuli are more robustly captured but this is at the expense of detailed information about what is evoking the reaction. Emotional cues individually vary in salience (Scherer et al., 2001; Tyang et al., 2017). However, many emotional cues such as contextual cues, body language, and vocal tone can work together to evoke an emotion, therefore a robust measure of an emotional cue may be more accurate than trying to isolate what evoked the emotion (Aviezer et al., 2012).

Attentional deployment was operationalized as the ratio of the sum percentage of time looking at all characters over the sum percentage of time looking at all backgrounds per video clip. As hypothesized, and consistent with research on attentional deployment, participants used more attentional deployment away from negatively evocative stimuli (i.e., looked more at the backgrounds than people; Gross, 2013). Participants also used more attentional deployment toward backgrounds when viewing the negative video clip than when viewing the ambiguously evocative video clip and more attentional deployment toward backgrounds when viewing the ambiguously evocative video clip than when viewing the positive video clip.

Post-hoc analyses compared attentional deployment in participants who rated the “classroom” scene as evoking positive emotions to participants who rated the scene as evoking negative emotions and no difference was found. The lack of difference suggests that participants

who rated the “classroom” scene as negative did not use more attentional deployment toward backgrounds than those who rated the video clip as positive. Since attentional deployment toward backgrounds was greatest for the negative clip, lesser for the ambiguously evocative clip, and the least for the positive clip; if the ambiguously evocative clip is perceived to evoke less negative emotion than the negative clip, but more negative emotion than the positive clip, then these results may be indicative of the need to measure intensity of emotion. As such, future research should adapt a measure of intensity as well as valence of emotions evoked in eye-tracking studies of attentional deployment. These results provide evidence of a novel and direct method of operationalizing and measuring the emotion regulation strategy, attentional deployment.

As hypothesized, participants also demonstrated differences in pupil dilation when comparing the positive, negative, and ambiguously evocative video clips. Participants had the greatest pupil diameter during the negative clip, smaller pupil diameter during the positive clip, and the smallest pupil diameter during the ambiguously evocative clip. Pupil diameter was used in the study as a method of measuring differences in arousal level. Dilated pupils have been related to increases in emotion arousal, cognitive effort, and memory retrieval (Bradley, Miccoli, Escrig, & Lang, 2008; Goldinger & Papesh, 2012). Accordingly, pupil dilation in the present research suggests that the negative video clip was the most arousing of the three video clips and the positive video clip was more arousing than the ambiguous clips.

Post-hoc analyses compared pupil diameter in participants who rated the ambiguous scene as evoking positive emotions to participants who rated the scene as evoking negative emotions and no difference was found. Therefore, participants who rated the ambiguous clip as positive and negative appeared to experience the same level of arousal from the video clip.

Bradley and colleagues monitored pupil diameter as well as skin conductance when showing the International Affective Picture System that has pleasant and unpleasant pictures ( $N = 27$ ,  $M_{age} = 18-22$  years) and found that regardless of emotional valence, participants' pupil diameter appeared to be greater if they experienced greater arousal when viewing the image. Their findings may explain why different patterns emerged when comparing attentional deployment to arousal levels for the same valences. Though the clip that evoked negative emotions showed the greatest attentional deployment and greatest arousal when compared to the clips that were positively and ambiguously evocative, this was not seen when comparing the positively and ambiguously evocative clips. More attentional deployment was used when viewing the ambiguously evocative clip compared to the positively evocative clip, but the pupil diameter results suggest that the positively evocative clip is more arousing than the ambiguously evocative clip.

Pupil diameter may also be indicative of cognitive effort and working memory (Izard, 2007). When considering how dynamic the process of regulating emotions is: emotional expression is determined by existing emotion schema (how one ascribes causality), the emotion evoked, appraisal and higher order cognitions, and the decision to implement the use of an emotion regulation strategy; it is possible the intensity of these processes are reflected in pupil diameter (Gross, 2013; Izard, 2007).

Overall, the first objective of the current project was met: eye-tracking was used as a direct measure of visual attentional deployment, results demonstrated more use of attentional deployment away from the negatively evocative stimuli, and different arousal levels were indicated by pupil diameter between stimuli of different emotion valences. This project provided



an operational definition of attentional deployment and a method to compare this emotion regulation strategy using video clips of different valences.

**Objective 2: How attentional deployment relates to other emotion regulation strategies**

When assessing if attention deployment predicts other emotion regulation strategies; specifically, cognitive reappraisal and expressive suppression, some hypotheses were supported. Less attentional deployment (i.e., spending more time looking at people than backgrounds) during the positively evocative scene was related to less overall use of cognitive reappraisal. One possible explanation of this finding is that individuals who use more cognitive reappraisal may evaluate faces more efficiently, therefore, if the need to downregulate negative emotions is low (as would be the case in a positively evocative video clip) then they may be scanning the rest of the scene due to the extra available time. Further research is required to clarify what this finding means. Bebko and colleagues' (2011) study, suggested that attention toward an evocative stimulus while using reappraisal techniques results in better mood. However, they did not test this phenomenon with positive valence images and they used a cognitive reappraisal task with guided attention in vivo. In the current research, contrary to hypotheses, attentional deployment when viewing the negative scene, ambiguously evocative scene, and film of moving shapes did not predict general use of the cognitive reappraisal strategy of emotion regulation. As well, in Study 2, attentional deployment when viewing the film of moving shapes did not predict cognitive reappraisal.

Attentional deployment during the ambiguously evocative clip predicted use of expressive suppression in Study 1, as hypothesized. This means that individuals who used attentional deployment (i.e., look away from evocative stimuli) during an uncertain, or ambiguous stimuli were more likely to suppress their emotional expression. It is possible that

this pattern is reflective of a lower tolerance of uncertainty or ambiguity, a pattern that is demonstrated by some individuals in a study of modes and styles of regulation in adulthood, who were found to primarily using repressive coping style and having a low tolerance of ambiguity ( $N = 156$ ;  $M = 47.40$ ; Labouvie-Vief & Medler, 2002). Expressive suppression and attentional deployment are both considered adaptive strategies in the short-term, but can result in poor outcomes with prolonged reliance on these strategies (Gross, 2013; Peckham & Johnson, 2018; Thiruchaselvam et al., 2011). Contrary to hypotheses, attentional deployment during the positive and negative video clips in Study 1 and the film of moving shapes in Study 2 did not predict expressive suppression. It is possible that differences in type of methods of measurement make the emotion regulation strategies difficult to compare. In the present research, the modality of measurement between these tasks differed; with attentional deployment being a real-time behavioural measure, while cognitive reappraisal and expressive suppression are questionnaires that reflect overall use of strategies. Bebko and colleagues (2011) addressed this issue by developing a cognitive reappraisal and expressive suppression task related to their video stimuli. However, their procedures were experimental tasks, whereas the Emotion Regulation Questionnaire is a standardized assessment tool with good validity (Gross & John, 2003). As well, Bebko and colleagues (2011) findings did not demonstrate relations between attentional deployment and cognitive reappraisal nor expressive suppression. However, results from the present research suggest that a state-dependent behavioural measure of attentional deployment can predict overall traits of emotion regulation strategies.

Gender was included as a control variable because studies have shown women use cognitive reappraisal strategies more effectively than men (McRae et al., 2018). However, gender did not predict use of cognitive reappraisal nor expressive suppression strategies.

The purpose of the second objective was to determine if attentional deployment is predictive of other emotion regulation strategies; specifically, cognitive reappraisal and expressive suppression. Results from Study 1 provide some evidence of attentional deployment being predictive of cognitive reappraisal and expressive suppression. As well, these relations are dependent on the emotional valence of the film clip presented, which may be indicative of differing stimuli evoking different methods of processing and regulating emotions. In Study 2, attentional deployment during a film of moving shapes was not predictive of cognitive reappraisal nor expressive suppression. Therefore, if further investigation is to be done in this area, video clips of people in positive and ambiguously evocative video clips, and possibly more detailed emotional range, may provide insight into this objective. Further investigation is also needed to understand if training attentional deployment strategies can result in changes in overall emotion regulation styles.

### **Objective 3: Emotion regulation and ADHD symptoms**

ADHD symptomology and impulsivity clustered into high and low symptom groups for both studies. In Study 1, as hypothesized, use of cognitive reappraisal was greater in the low ADHD symptom group. However, this difference was not seen between the groups in Study 2. A post-hoc analysis showed that, overall, participants in Study 2 reported higher levels of impulsivity, with a mean above the clinical cutoff of 72, than the participants in Study 1, and no difference in ADHD symptoms. Contrary to hypotheses, expressive suppression and attentional deployment did not differ between the high and low ADHD symptoms groups in both studies. In Study 1, participants with greater ADHD symptom and greater impulsivity (not in a clinically significant range), showed less use of self-reported cognitive reappraisal strategies compared to the lower ADHD symptom/impulsivity group. In contrast, results from Study 2 showed that

participants with greater ADHD and greater impulsivity (in a clinically significant range), did not demonstrate a difference in self-reported use of cognitive reappraisal strategies when compared to the lower ADHD symptom/impulsivity group. It is possible that the participants in Study 2, who demonstrated greater ADHD symptoms as well as greater impulsivity (in the clinical range), face greater impairment, and demonstrate a lack of insight into the emotion regulation strategies that they use (Uekermann et al., 2010).

The present research studied population-occurring ADHD symptomology in undergraduate students and the number of individuals who had a formal diagnosis of ADHD in the sample for the current research was quite small. Individuals with greater ADHD symptoms and greater impulsivity, who attend higher education, are likely to have greater cognitive abilities and more adaptive skills (such as good emotion regulation) that allow them to be successful students in higher education (Ditterline, Banner, Oakland, & Becton, 2008). In a study of coping strategies used by adults with ADHD, greater cognitive ability was related to better coping ( $N_{ADHD} = 44$ ,  $N_{healthy\ controls} = 34$ ; Young, 2004).

Cognitive reappraisal is an adaptive method of regulating emotions, and was demonstrated by individuals in the low ADHD/impulsivity group. Individuals who do not have ADHD demonstrate better use of cognitive reappraisal strategies (Young, 2004). Poor emotion regulation is a defining characteristic of ADHD and can result in poor outcomes with regard to social relationships, self-esteem, and overall psychological adjustments (Lopes et al., 2005; Nezlek & Kuppens, 2008). Therefore, understanding the varying ADHD symptom profiles and how they influence insight into and use of emotion regulation strategies can inform emotion-regulation therapeutic intervention for individuals with greater ADHD symptoms.

This project provided some insight into Objective 3, looking at differences in emotion regulation in the high vs. low symptoms groups for ADHD/impulsivity. Results of the project pointed to different ADHD symptom profiles (e.g., greater ADHD symptoms with clinically significant impulsivity vs. greater ADHD symptoms with subclinical impulsivity) resulting in different self-reported use of cognitive reappraisal. Further research is required into the varying symptom profiles in the subclinical and clinical range (with a formal diagnosis) of ADHD and how they relate to use of cognitive reappraisal or other emotion regulation strategies.

#### **Objective 4: Attentional deployment when viewing people vs. shapes**

When comparing attentional deployment while viewing video clips of people (in Study 1) to a video of moving shapes (Study 2), as hypothesized, participants demonstrated greater attentional deployment (i.e., looked more at backgrounds than characters) when viewing the video of shapes, which is often interpreted as evoking negative emotions (Klin, 2006) as compared to viewing the positive video clip of people. As well, participants demonstrated greater attentional deployment when viewing the negative clip of people than when viewing the video of moving shapes. However, attentional deployment did not significantly differ between the ambiguously evocative video clip and the video of moving shapes. Similar to the results from Study 1, results in Study 2 provide further evidence that attentional deployment occurs more with stimuli that evoked negative emotions; because greater attentional deployment occurred during the film of moving shapes than the positive scene of people (Gross, 2013). Therefore, results suggest that a film of moving shapes can evoke a similar type of visual response as a film of people. These results may point to the importance of appraisal in evoking emotions or attentional deployment, even in the absence of human cues. Research shows appraisal can change the need to regulate emotions and this has been demonstrated in individuals who

experience anticipatory fear due to an upcoming speech (Yoon & Zinbarg, 2008). For example, undergraduate students, who experienced anticipatory fear (due to an upcoming speech), interpreted neutral faces as negative, but did not do so when they were not experiencing anticipatory fear ( $N = 23$ ; Yoon & Zinbarg, 2008). These differences in appraisal resulted in different emotional experiences and, therefore, would result in different need to regulate (Tamir, 2014).

When considering that the negative scene of people had more attentional deployment than the film of moving shapes, this may be demonstrative of intensity of emotions felt when viewing the clips. Body language cues can be used to discriminate between intense positive and negative emotions (Aviezer, Trope, & Todorov, 2012). The negative video clip had human cues (e.g., body language, facial expressions, tone of voice, volume) that could have intensified the emotional reaction when compared to the film of moving shapes. In the ambiguously evocative video clip, participants were divided in whether the film evoked a positive or negative emotion. It is possible that the film of moving shapes evoked the same level of emotionality that the ambiguous clip did and, therefore, the need to use attentional deployment to regulate emotions could have also been similar.

The fourth objective was to identify how attentional deployment differed when viewing a video clip of people as compared to a video clip of moving shapes; this objective was met. Findings provided further evidence that a negatively evocative video clip is more likely to result in attentional deployment away from the evocative areas of the clip because the film of moving shapes is often interpreted as a negative interaction (Klin, 2006). As well, results provide some interesting insight into whether human stimuli are necessary for both evoking emotions and, consequently, needing to regulate emotions. Heider and Simmel's film of moving shapes has

been widely adapted for a variety of applications, and it continues to provide insights into appraisal, with this novel adaptation of the film to quantify attentional deployment.

### **Limitations the Current Research**

The limitations and strengths of this project are discussed further below and include a consideration of eye-tracking technology, the video stimulus of “The Perks of Being a Wallflower”, and the generalizability of the study.

There is an assumption made when using eye-tracking that an individual is paying attention to what they are looking at. However, it is possible for someone to demonstrate visual focus on one point, while their attention may be on peripheral cues or even something unrelated to the visual stimuli (Goldstein & Brockmole, 2016). For example, if someone is looking at the stimulus but thinking about what they will have for dinner, what they are looking at is not a measure of what they are attending to.

With regard to the video stimulus of “The Perks of Being a Wallflower”, the fame of some of the actors may have complicated what drove visual attention. For example, Nina Dobrev played a peripheral character but her fame, compared to the main character, could have resulted in more people looking at her instead of deploying attention, which the participant may have done if presented with an unfamiliar actor.

Though “The Perks of Being a Wallflower” was selected because it had realistic, emotionally evocative situations with similarly aged individuals to those completing the study, viewing a film does not account for real-world social interactions that are reciprocal. Attentional deployment can occur after experiencing an evocative event, but in a social interaction, the feedback from the social partner can provide information about whether the goals of regulation are being met, if the strategy is working, or if a different emotion regulation strategy would be

better to use (Gross, 2013; Tamir, 2011). The film of moving shapes is also not directly generalizable to day-to-day interactions. However, as eye-tracking technology advances, attentional deployment may be measurable in real-world social interactions and this study provides a foundational template for measuring attentional deployment.

### **Clinical and Real-World Applications**

There are a number of areas in which clinical and real-world applications for the use of eye-tracking attentional deployment can be relevant including forensic settings, therapeutic intervention, and meditative practices.

The video clips in Study 1 were selected to represent realistic scenarios of people. Exploring the content of the scenes provides some insight into potential situations that evoke attentional deployment toward a neutral stimulus. When considering the negative “slap” scene, a young man witnesses a domestic violence situation with his sister and her boyfriend. The response of looking away to regulate emotions can have implications in real-world situations. Participants demonstrated attentional deployment away from the evocative stimulus (i.e., people). In an extreme example, if someone is witnessing a crime and looks away in order to regulate emotions, the emotion regulation may affect their quality of reporting (Neal & Brodsky, 2008).

In the film of moving shapes, the shapes are designed to look like they move in response to the movements of the other shapes. However, not everyone interprets these shapes in the same way (e.g., a parent-child conflict vs. a romantic partner conflict). Participants’ use of greater attentional deployment toward backgrounds when viewing the clip of moving shapes, often interpreted as negative, then when viewing the positive clip of people may be evidence of the subjective nature of emotional appraisal and, therefore, the emotional experience. When adapting



this concept to real-world scenarios where participants use attentional deployment strategies, the same situation can evoke more or less attentional deployment, depending on how the situation is interpreted. One's mood state can influence attentional bias (Tyang et al., 2017). For example, when comparing individuals who are socially anxious to those who are not, entering a neutral social situation with a new person may result in different emotional experiences. If the individual interprets the situation as negative, they may demonstrate gaze aversion, as is often seen in individuals with social anxiety (Schneier, Rodebaugh, Blanco, Lewing, & Liebowitz, 2011). One possible research application for adapting the measure of attentional deployment during the film of moving shapes is pre- and post- treatment of social anxiety, and whether participants demonstrate less attentional deployment after treatment.

Emotion regulation is typically a focus of clinical intervention because effective emotion regulation can promote mental and physical health, adaptive functioning, and successful interpersonal relationships (Berking & Wupperman, 2012; Lopes et al., 2005; Tamir, 2011). Research suggests that the use of attentional deployment, compared to cognitive reappraisal or expressive suppression, requires minimal effort (Sheppes & Gross, 2011). Attentional deployment is also an adaptive strategy to use in the short-term (Thiruchaselvam et al., 2011). Gaze training toward positively evocative stimuli has been found to improve mood (Sanchez, Vazquez, Gomez, & Joormann, 2014). Therefore, learning how to redirect attention, through gaze training, in combination with adaptive emotion regulation strategies like cognitive reappraisal may be a useful intervention.

Gaze training, or learning how to redirect attention, is similar to meditation practices, which are characterized by practicing mindful awareness and concentration (Pavlov et al., 2015). Meditation practices have been found to improve control of attentional focus. In an eye-tracking

study, healthy controls ( $N = 21$ ) were compared to experienced meditators ( $N = 23$ ) on attentional bias toward neutral and emotional faces. Experienced meditators were found to attend more to happy faces and less to angry and fearful faces than the health controls ( $M_{meditators} = 36.3$ ,  $SD = 8.8$ ;  $M_{control} = 32.8$ ,  $SD = 6.0$ ; Pavlov et al., 2015). Future research may be able to apply eye-tracking attentional deployment to real-world situations such as mental health interventions and forensic reporting.

### **Future Research**

There is an intimate relationship between the advancement of eye-tracking technology with what research is possible. At the present time, developing precise, dynamic areas of interest for moving stimuli is extremely time-consuming, and impractical for research. As this technology advances and less time is needed to develop these types of areas of interest, adapting eye-tracking to a standardized video clip of emotions for measuring attentional deployment can be developed. As well, with advances in mobile eye-tracking and their increasing accuracy of recording visual focus, participants use of attentional deployment can be measured in real-world interactions (SR Research, 2016). Similarly, as research on emotion regulation continues to develop, particularly in the area of attentional deployment, it can change the way in which attentional deployment is measured. This study represents an early attempt to make links between the eye-tracking and attentional deployment during social interactions. Future research that can build on the findings of the present research are presented by objectives.

In the first objective, the aim was to use eye-tracking as a direct measure of attentional deployment. Using eye-tracking with video clips of different emotional valence has been shown as a viable measure of attentional deployment. For a standard measure of attentional deployment, developing a scale in which participants can record a variety of emotions and emotional intensity

may be useful. Within each valence (e.g., negative) there are a variety of emotions that can be experienced (e.g., sadness, anger, disgust) and it is worth exploring if the specific emotion evoked changes the use of attentional deployment to regulate.

The second objective aimed to determine if attentional deployment was predictive of cognitive reappraisal. Results demonstrated that attentional deployment toward backgrounds during the ambiguously evocative video clip of people and the positive clip of people were predictive of more expressive suppression and more cognitive reappraisal, respectively. As such, further research into different types and intensity of emotions while viewing video clips of people may provide insight into how attentional deployment, in the moment, relates to overall use of cognitive reappraisal and expressive suppression strategies.

In the third objective, the aim was to identify if individuals with higher ADHD and impulsivity symptoms demonstrated different emotion regulation than individuals with lower ADHD and impulsivity. Results pointed to varying ADHD profiles (e.g., high ADHD symptoms with clinically significant impulsivity vs. high ADHD symptoms with non-clinically significant impulsivity) either using cognitive reappraisal strategies differently or representing a lack of insight into use of emotion regulations strategies. Therefore, future research can measure emotion regulation using multiple reporters of individuals with varying clinical and non-clinical ADHD profiles to identify how individuals differ in use of cognitive reappraisal as well as other emotion regulation strategies.

The fourth objective aimed to identify if attentional deployment differed between video clips of people compared to an evocative video of moving shapes. More attentional deployment away from the evocative stimuli in the negative video clip of people compared to the film of moving shapes provides further evidence that measuring the intensity of emotion experienced.

As well, participants demonstrating more attentional deployment away from the evocative stimuli in the film of moving shapes compared to the positive clip of people provide insight into the appraisal process. Future research can compare visual scanning patterns of the scene to participants' self-report of how they determined what emotion the scene evoked to better understand the conscious emotional appraisal process.

## **Conclusions**

This dissertation presents a novel method of directly measuring attentional deployment, using precise areas of interest in video clips to measure visual attention. Though developing dynamic areas of interest were extremely time consuming in the current research project, this may change with future advances in technology. This project gives insight into the type of analyses that can be conducted as eye-tracking technology advances and dynamic areas of interest can be developed more quickly with precision. The precision allowed for nuanced distinction between characters and backgrounds to be captured. An operational definition of attentional deployment was developed for this research project, which was a ratio of total percentage of time looking at people/characters over total percentage of time looking at backgrounds. This operationalization provides a template for a standardized value to quantify attentional deployment, which is an original contribution to the emotion regulation literature. Next steps would be psychometric testing of the attentional deployment ratio. Pupil diameter was interpreted in conjunction with the attentional deployment, and it can serve as a manipulation check to ensure participants are experiencing different levels of arousal. The addition of intensity of valence can enhance research into attentional deployment. Participants consistently demonstrated that when viewing a scene that was negatively evocative, they used more attentional deployment away from the evocative stimuli for both the video clips of people and

the film of of moving shapes. The results from the film of moving shapes also provided some insight into the appraisal process of emotion regulation. Attentional deployment during different valence video clips was predictive of overall use of cognitive reappraisal and expressive suppression, suggesting that positive and ambiguously evocative video clips likely result in different methods of processing and regulating emotions. As well, varying ADHD symptom profiles demonstrated different use of emotion regulation strategies. Findings highlight the potential for adapting this measurement to real-world interactions.

## REFERENCES

- Aldao, A., Nolen-Hoeksema, S., & Schweizer, S. (2010). Emotion-regulation strategies across psychopathology: A meta-analytic review. *Clinical psychology review, 30*(2), 217-237. <https://doi.org/10.1016/j.cpr.2009.11.004>
- American Psychiatric Association (APA). (2013). *Diagnostic and statistical manual of mental disorders: DSM-5*. Arlington, VA: American Psychiatric Association.
- Aviezer, H., Trope, Y., & Todorov, A. (2012). Body cues, not facial expressions, discriminate between intense positive and negative emotions. *Science, 338*(6111), 1225-1229. doi: 10.1126/science.122431
- Bardone-Cone, A. M., Calhoun, C. D., Fischer, M. S., Gaskin-Wasson, A. L., Jones, S. C. T., Schwartz, S. L., Wise, E. H., & Prinstein, M. J. Development and implementation of a diversity training sequence in a clinical psychology doctoral program. *The Behaviour Therapist, 39*(3), 65-97. Retrieved from: <http://psycnet.apa.org.ezproxy.uwindsor.ca/record/2016-35101-001>
- Bargh, J. A., & Williams, L. E. (2007). The nonconscious regulation of emotion. In J. J. Gross (Ed.), *Handbook of emotion regulation* (429-445). New York: Guilford Press.
- Barratt, E. S. (1994). Impulsiveness and aggression. In J. Monahan J & H. J. Steadman (Eds.). *Violence and mental disorder* (pp. 61–79). Chicago: University of Chicago Press.
- Beauchaine, T. P., & Neuhaus, E. (2008). Impulsivity and vulnerability to psychopathology. In T. P. Beauchaine & S. P. Hinshaw (Eds.), *Child and adolescent psychopathology* (129-156). Hoboken, NJ: John Wiley & Sons, Inc.

- Bebko, G. M., Franconeri, S. L., Ochsner, K. N., & Chiao, J. Y. (2011). Look before you regulate: differential perceptual strategies underlying expressive suppression and cognitive reappraisal. *Emotion, 11*(4), 732-742. <http://dx.doi.org/10.1037/a0024009>
- Berking, M., & Wupperman, P. (2012). Emotion regulation and mental health: recent findings, current challenges, and future directions. *Current opinion in psychiatry, 25*(2), 128-134. doi: 10.1097/YCO.0b013e3283503669
- Berlin, H. A., & Hollander, E. (2008). Understanding the differences between impulsivity and compulsivity. *Psychiatric Times, 25*(8), 58-58. Retrieved from <http://go.galegroup.com/ps/anonymous?id = GALE%7CA181302413&sid = googleScholar&v = 2.1&it = r&linkaccess = fulltext&issn = 08932905&p = AONE&sw = w&authCount = 1&isAnonymousEntry = true>Butler, Egloff, Wilhelm, Smith, Erickson, & Gross, 2003
- Bradley, M. M., Miccoli, L., Escrig, M. A., & Lang, P. J. (2008). The pupil as a measure of emotional arousal and autonomic activation. *Psychophysiology, 45*(4), 602-607. <https://doi.org/10.1111/j.1469-8986.2008.00654.x>
- Cappadocia, M. C., Desrocher, M., Pepler, D., & Schroeder, J. H. (2009). Contextualizing the neurobiology of conduct disorder in an emotion dysregulation framework. *Clinical psychology review, 29*(6), 506-518. <https://doi.org/10.1016/j.cpr.2009.06.001>
- Cisler, J. M., Olatunji, B. O., Feldner, M. T., & Forsyth, J. P. (2010). Emotion regulation and the anxiety disorders: an integrative review. *Journal of psychopathology and behavioral assessment, 32*(1), 68-82. Retrieved from: <https://link.springer.com/article/10.1007/s10862-009-9161-1>
- Cohen, J. (1992). A power primer. *Psychological Bulletin, 112*, 155-159.

- Cutuli, D. (2014). Cognitive reappraisal and expressive suppression strategies role in the emotion regulation: an overview on their modulatory effects and neural correlates. *Frontiers in systems neuroscience*, 8, 175. <https://doi.org/10.3389/fnsys.2014.00175>
- Cyders, M. A., & Coskunpinar, A. (2012). The relationship between self-report and lab task conceptualizations of impulsivity. *Journal of Research in Personality*, 46(1), 121-124. <https://doi.org/10.1016/j.jrp.2011.11.005>
- de Wit, H. (2009). Impulsivity as a determinant and consequence of drug use: a review of underlying processes. *Addiction biology*, 14(1), 22-31. doi. 10.1111/j.1369-1600.2008.00129.x
- Ditterline, J., Banner, D., Oakland, T., & Becton, D. (2008). Adaptive behavior profiles of students with disabilities. *Journal of Applied School Psychology*, 24(2), 191-208. <https://doi.org/10.1080/15377900802089973>
- Dougherty, D. M., Marsh, D. M., & Mathias, C. W. (2002). Immediate and delayed memory tasks: a computerized behavioral measure of memory, attention, and impulsivity. *Behavior research methods, instruments, & computers*, 34(3), 391-398. Retrieved from: <https://link.springer.com/article/10.3758/BF03195467>
- English, T., John, O. P., & Gross, J. J. (2013). Emotion regulation in close relationships. In J. A. Simpson & L. Campbell (Eds.), *The Oxford handbook of close relationships* (pp. 500–513). New York: Oxford University Press.
- Faul, F., Erdfelder, E., Lang, A.G., & Buchner, A. (2007). G\*Power 3: A flexible statistical power analysis program for the social, behavioral, and biomedical sciences. *Behavior Research Methods*, 39, 175-191. doi:10.3758/BF03193146
- Field, A. (2013). *Discovering statistics using IBM SPSS statistics*. Sage.



- Füstös, J., Gramann, K., Herbert, B. M., & Pollatos, O. (2012). On the embodiment of emotion regulation: interoceptive awareness facilitates reappraisal. *Social cognitive and affective neuroscience*, 8(8), 911-917. <https://doi.org/10.1093/scan/nss089>
- Gobbini, M. I., Koralek, A. C., Bryan, R. E., Montgomery, K. J., & Haxby, J. V. (2007). Two takes on the social brain: a comparison of theory of mind tasks. *Journal of cognitive neuroscience*, 19(11), 1803-1814. doi: 10.1162/jocn.2007.19.11.1803
- Goldin, P. R., & Gross, J. J. (2010). Effects of mindfulness-based stress reduction (MBSR) on emotion regulation in social anxiety disorder. *Emotion*, 10(1), 83-91.  
<http://dx.doi.org/10.1037/a0018441>
- Goldinger, S. D., & Papesh, M. H. (2012). Pupil dilation reflects the creation and retrieval of memories. *Current Directions in Psychological Science*, 21(2), 90-95.  
<https://doi.org/10.1177/0963721412436811>
- Goldstein, E. B., & Brockmole, J. (2016). *Sensation and perception*. Cengage Learning.
- Graziano, P. A., Calkins, S. D., & Keane, S. P. (2011). Sustained attention development during the toddlerhood to preschool period: Associations with toddlers' emotion regulation strategies and maternal behaviour. *Infant and Child Development*, 20(6), 389-408.  
<https://doi.org/10.1002/icd.731>
- Greenhouse, S. W., & Geisser, S. (1959). On methods in the analysis of profile data. *Psychometrika*, 24(2), 95-112. Retrieved from:  
<https://pdfs.semanticscholar.org/3cfb/179109460df8e52e649eb90c20f1d01f314b.pdf>
- Gross, J. J. (1998a). Antecedent-and response-focused emotion regulation: divergent consequences for experience, expression, and physiology. *Journal of personality and social psychology*, 74(1), 224-237. <http://dx.doi.org/10.1037/0022-3514.74.1.224>

- Gross, J. J. (1998b). The emerging field of emotion regulation: an integrative review. *Review of general psychology*, 2(3), 271-299. <http://dx.doi.org/10.1037/1089-2680.2.3.271>
- Gross, J. J. (2013). *Handbook of emotion regulation*. New York: Guilford Press.
- Gross, J. J., & Barrett, L. F. (2011). Emotion generation and emotion regulation: One or two depends on your point of view. *Emotion review*, 3(1), 8-16. doi: 10.1177/1754073910380974
- Gross, J. J., & John, O. P. (2003). Individual differences in two emotion regulation processes: implications for affect, relationships, and well-being. *Journal of personality and social psychology*, 85(2), 348-362. <http://dx.doi.org.ezproxy.uwindsor.ca/10.1037/0022-3514.85.2.348>
- Grühn, D., & Scheibe, S. (2008). Age-related differences in valence and arousal ratings of pictures from the International Affective Picture System (IAPS): Do ratings become more extreme with age? *Behavior Research Methods*, 40(2), 512-521. doi: 10.3758/BRM.40.2.512
- Halfon, L., Smith, R., Malkovich, J. (Producers), & Chbosky, S. (Director). (2012). *The perks of being a wallflower* [Motion picture]. United States: Summit Entertainment.
- Harris, C. R. (2001). Cardiovascular responses of embarrassment and effects of emotional suppression in a social setting. *Journal of personality and social psychology*, 81(5), 886-897. <http://dx.doi.org/10.1037/0022-3514.81.5.886>
- Haga, S. M., Kraft, P., & Corby, E. K. (2009). Emotion regulation: Antecedents and well-being outcomes of cognitive reappraisal and expressive suppression in cross-cultural samples. *Journal of Happiness Studies*, 10(3), 271-291. Retrieved from: <https://link.springer.com/article/10.1007/s10902-007-9080-3>

- Heberlein, A. S., & Adolphs, R. (2004). Impaired spontaneous anthropomorphizing despite intact perception and social knowledge. *Proceedings of the National Academy of Sciences*, *101*(19), 7487-7491. <https://doi.org/10.1073/pnas.0308220101>
- Heider, F., & Simmel, M. (1944). An experimental study of apparent behavior. *The American Journal of Psychology*, *57*(2), 243-259. doi: 10.2307/1416950
- Huynh, H., & Feldt, L. S. (1976). Estimation of the Box correction for degrees of freedom from sample data in randomized block and split-plot designs. *Journal of educational statistics*, *1*(1), 69-82. <https://doi.org/10.3102/10769986001001069>
- Isaacowitz, D. M., Livingstone, K. M., Harris, J. A., & Marcotte, S. L. (2015). Mobile eye tracking reveals little evidence for age differences in attentional selection for mood regulation. *Emotion*, *15*(2), 151-161. <http://dx.doi.org/10.1037/emo0000037>
- Izard, C. E. (2007). Basic emotions, natural kinds, emotion schemas, and a new paradigm. *Perspectives on psychological science*, *2*(3), 260-280. <https://doi.org/10.1111/j.1745-6916.2007.00044.x>
- Johnson, D. R. (2009). Goal-directed attentional deployment to emotional faces and individual differences in emotional regulation. *Journal of Research in Personality*, *43*(1), 8-13. <https://doi.org/10.1016/j.jrp.2008.09.006>
- Just, M. A., Carpenter, P. A., & Miyake, A. (2003). Neuroindices of cognitive workload: Neuroimaging, pupillometric and event-related potential studies of brain work. *Theoretical Issues in Ergonomics Science*, *4*(1-2), 56-88. <http://dx.doi.org/10.1080/14639220210159735>

- Kaltiala-Heino, R., Rimpelä, M., Rantanen, P., & Rimpelä, A. (2000). Bullying at school—an indicator of adolescents at risk for mental disorders. *Journal of adolescence*, *23*(6), 661-674. <https://doi.org/10.1006/jado.2000.0351>
- Kashdan, T. B., & Steger, M. F. (2006). Expanding the topography of social anxiety: An experience-sampling assessment of positive emotions, positive events, and emotion suppression. *Psychological Science*, *17*(2), 120-128. <https://doi.org/10.1111/j.1467-9280.2006.01674.x>
- Keith, T. Z. (2014). *Multiple regression and beyond: An introduction to multiple regression and structural equation modeling*. Routledge.
- Kessler, R. C., Adler, L., Ames, M., Demler, O., Faraone, S., Hiripi, E. V. A., ... & Ustun, T. B. (2005). The World Health Organization Adult ADHD Self-Report Scale (ASRS): a short screening scale for use in the general population. *Psychological medicine*, *35*(2), 245-256. <https://doi.org/10.1017/S0033291704002892>
- Kimble, M. O., Fleming, K., Bandy, C., Kim, J., & Zambetti, A. (2010). Eye tracking and visual attention to threatening stimuli in veterans of the Iraq war. *Journal of anxiety disorders*, *24*(3), 293-299. <https://doi.org/10.1016/j.janxdis.2009.12.006>
- Klein, A. M., Zwickel, J., Prinz, W., & Frith, U. (2009). Animated triangles: An eye tracking investigation. *The Quarterly Journal of Experimental Psychology*, *62*(6), 1189-1197. <https://doi.org/10.1080/17470210802384214>
- Klin, A. (2000). Attributing social meaning to ambiguous visual stimuli in higher-functioning autism and Asperger syndrome: the social attribution task. *Journal of Child psychology and Psychiatry*, *41*(7), 831-846. doi: 10.1111/1469-7610.00671

- Klin, A., Jones, W., Schultz, R., Volkmar, F., & Cohen, D. (2002). Visual fixation patterns during viewing of naturalistic social situations as predictors of social competence in individuals with autism. *Archives of general psychiatry*, *59*(9), 809-816. doi: 10.1001/archpsyc.59.9.809
- Kloosterman, N. A., Meindertsma, T., van Loon, A. M., Lamme, V. A., Bonnef, Y. S., & Donner, T. H. (2015). Pupil size tracks perceptual content and surprise. *European Journal of Neuroscience*, *41*(8), 1068-1078. <https://doi.org/10.1111/ejn.12859>
- Labouvie-Vief, G., & Medler, M. (2002). Affect optimization and affect complexity: Modes and styles of regulation in adulthood. *Psychology and aging*, *17*(4), 571 -588. <http://dx.doi.org/10.1037/0882-7974.17.4.571>
- Lee, H., Heller, A. S., Van Reekum, C. M., Nelson, B., & Davidson, R. J. (2012). Amygdala–prefrontal coupling underlies individual differences in emotion regulation. *Neuroimage*, *62*(3), 1575-1581. <http://dx.doi.org/10.1016/j.neuroimage.2012.05.044>
- LeDoux, J. (2007). The amygdala. *Current biology*, *17*(20), R868-R874. Retrieved from: [https://www.cell.com/current-biology/pdf/S0960-9822\(07\)01779-4.pdf](https://www.cell.com/current-biology/pdf/S0960-9822(07)01779-4.pdf)
- Lohani, M., & Isaacowitz, D. M. (2014). Age differences in managing response to sadness elicitors using attentional deployment, positive reappraisal and suppression. *Cognition & emotion*, *28*(4), 678-697. <https://doi.org/10.1080/02699931.2013.853648>
- Lopes, P. N., Salovey, P., Côté, S., Beers, M., & Petty, R. E. (2005). Emotion regulation abilities and the quality of social interaction. *Emotion*, *5*(1), 113-118. <http://dx.doi.org/10.1037/1528-3542.5.1.113>
- Marinho, F., Carvalho, C. M., Apolinário, F. R., & Paulucci, L. (2019). Measuring light with

- light dependent resistors: an easy approach for optics experiments. *arXiv preprint arXiv:1903.1-13*. Retrieved from: <https://arxiv.org/pdf/1903.10053.pdf>
- Marshall, S. P. (2007). Identifying cognitive state from eye metrics. *Aviation, space, and environmental medicine*, 78(5), B165-B175. Retrieved from: <http://www.ingentaconnect.com/content/asma/ase/2007/00000078/a00105s1/art00025>
- Martel, M. M. (2009). Research review: A new perspective on attention-deficit/hyperactivity disorder: Emotion dysregulation and trait models. *Journal of Child Psychology and Psychiatry*, 50(9), 1042-1051. Retrieved from: <https://pdfs.semanticscholar.org/8412/1283f3650a8f6758336b39e938a9c25134c5.pdf>
- McRae, K., Ochsner, K. N., Mauss, I. B., Gabrieli, J. J., & Gross, J. J. (2008). Gender differences in emotion regulation: An fMRI study of cognitive reappraisal. *Group processes & intergroup relations*, 11(2), 143-162. <https://doi.org/10.1177/1368430207088035>
- Mesquita, B., De Leersnyder, J., & Albert, D. (2013). The cultural regulation of emotions. In J. J. Gross (Ed.), *Handbook of emotion regulation* (2<sup>nd</sup> ed., pp. 284–302). New York: Guilford Press.
- Mignault, A., & Chaudhuri, A. (2003). The many faces of a neutral face: Head tilt and perception of dominance and emotion. *Journal of nonverbal behavior*, 27(2), 111-132. <https://doi.org/10.1023/A:1023914509763>
- Moscovitch, D. A., Gavric, D. L., Senn, J. M., Santesso, D. L., Miskovic, V., Schmidt, L. A., ... & Antony, M. M. (2012). Changes in judgment biases and use of emotion regulation strategies during cognitive-behavioral therapy for social anxiety disorder: distinguishing

- treatment responders from nonresponders. *Cognitive Therapy and Research*, 36(4), 261-271. doi: 10.1007/s10608-011-9371-1
- Nandagopal, J. J., Fleck, D. E., Adler, C. M., Mills, N. P., Strakowski, S. M., & DelBello, M. P. (2011). Impulsivity in adolescents with bipolar disorder and/or attention-deficit/hyperactivity disorder and healthy controls as measured by the Barratt Impulsiveness Scale. *Journal of child and adolescent psychopharmacology*, 21(5), 465-468. <https://doi.org/10.1089/cap.2010.0096>
- Neal, T. M., & Brodsky, S. L. (2008). Expert witness credibility as a function of eye contact behavior and gender. *Criminal Justice and Behavior*, 35(12), 1515-1526. <https://doi.org/10.1177/0093854808325405>
- Nezlek, J. B., & Kuppens, P. (2008). Regulating positive and negative emotions in daily life. *Journal of personality*, 76(3), 561-580. <https://doi.org/10.1111/j.1467-6494.2008.00496.x>
- Nolen-Hoeksema, S., & Aldao, A. (2011). Gender and age differences in emotion regulation strategies and their relationship to depressive symptoms. *Personality and individual differences*, 51(6), 704-708. <https://doi.org/10.1016/j.paid.2011.06.012>
- Patton, J. H., Stanford, M. S., & Barratt, E. S. (1995). Factor structure of the Barratt impulsiveness scale. *Journal of clinical psychology*, 51(6), 768-774. [https://doi.org/10.1002/1097-4679\(199511\)51:6<768::AID-JCLP2270510607>3.0.CO;2-1](https://doi.org/10.1002/1097-4679(199511)51:6<768::AID-JCLP2270510607>3.0.CO;2-1)
- Pavlov, S. V., Korenyok, V. V., Reva, N. V., Tummyalis, A. V., Loktev, K. V., & Aftanas, L. I. (2015). Effects of long-term meditation practice on attentional biases towards emotional

- faces: An eye-tracking study. *Cognition and Emotion*, 29(5), 807-815.  
<https://doi.org/10.1080/02699931.2014.945903>
- Peckham, A. D., & Johnson, S. L. (2018). Cognitive control training for emotion-related impulsivity. *Behaviour research and therapy*, 105, 17-26.  
<https://doi.org/10.1016/j.brat.2018.03.009>
- Poole, A., & Ball, L. J. (2006). Eye tracking in HCI and usability research. In *Encyclopedia of human computer interaction* (pp. 211-219). IGI Global.
- Portney, L. G., & Watkins, M. P. (2000). Validity of measurements. *Foundations of clinical research: Applications to practice*, 2.
- Ray, R. D., Ochsner, K. N., Cooper, J. C., Robertson, E. R., Gabrieli, J. D., & Gross, J. J. (2005). Individual differences in trait rumination and the neural systems supporting cognitive reappraisal. *Cognitive, Affective, & Behavioral Neuroscience*, 5(2), 156-168. Retrieved from: <https://link.springer.com/article/10.3758/CABN.5.2.156>
- Reid, R. C., Cyders, M. A., Moghaddam, J. F., & Fong, T. W. (2013). Psychometric properties of the Barratt Impulsiveness Scale in patients with gambling disorders, hypersexuality, and methamphetamine dependence. *Addictive behaviors*, 39(11), 1640-1645. doi: 10.1016/j.addbeh.2013.11.008
- Ross, L. A., & Olson, I. R. (2010). Social cognition and the anterior temporal lobes. *Neuroimage*, 49(4), 3452-3462.  
<http://dx.doi.org/10.1016/j.neuroimage.2009.11.012>
- Sanchez, A., Vazquez, C., Gomez, D., & Joormann, J. (2014). Gaze-fixation to happy faces predicts mood repair after a negative mood induction. *Emotion*, 14(1), 85-94. doi: 10.1037/a0034500



- Scheibe, S., & Zacher, H. (2013). A lifespan perspective on emotion regulation, stress, and well-being in the workplace. In *The role of emotion and emotion regulation in job stress and well being* (pp. 163-193). Emerald Group Publishing Limited.
- Schneier, F. R., Rodebaugh, T. L., Blanco, C., Lewin, H., & Liebowitz, M. R. (2011). Fear and avoidance of eye contact in social anxiety disorder. *Comprehensive Psychiatry*, *52*(1), 81-87. <https://doi.org/10.1016/j.comppsy.2010.04.006>
- Scherer, K. R., Schorr, A., & Johnstone, T. (Eds.). (2001). *Appraisal processes in emotion: Theory, methods, research*. Oxford University Press.
- Schreiber, L. R., Grant, J. E., & Odlaug, B. L. (2012). Emotion regulation and impulsivity in young adults. *Journal of psychiatric research*, *46*(5), 651-658. <https://doi.org/10.1016/j.jpsychires.2012.02.005>
- Schurz, M., Radua, J., Aichhorn, M., Richlan, F., & Perner, J. (2014). Fractionating theory of mind: a meta-analysis of functional brain imaging studies. *Neuroscience & Biobehavioral Reviews*, *42*, 9-34. <https://doi.org/10.1016/j.neubiorev.2014.01.009>
- Sheppes, G., & Gross, J. J. (2011). Is timing everything? Temporal considerations in emotion regulation. *Personality and Social Psychology Review*, *15*(4), 319-331. <https://doi.org/10.1177/1088868310395778>
- SR Research Ltd. (2016). *EyeLink user manual*. Retrieved from [http://www.hum.uu.nl/uilots/lab/resources/EyeLink1000\\_UserManual.pdf](http://www.hum.uu.nl/uilots/lab/resources/EyeLink1000_UserManual.pdf)
- Stanford, M. S., Mathias, C. W., Dougherty, D. M., Lake, S. L., Anderson, N. E., & Patton, J. H. (2009). Fifty years of the Barratt Impulsiveness Scale: An update and review. *Personality and Individual Differences*, *47*(5), 385-395. <http://dx.doi.org/10.1016/j.paid.2009.04.008>

- Tabachnick, B. G., & Fidell, L. S. (2001). Logistic regression. *Using multivariate statistics*, 5, 437-505.
- Tamir, M. (2011). The maturing field of emotion regulation. *Emotion Review*, 3(1), 3-7.  
<https://doi.org/10.1177/1754073910388685>
- Thiruchselvam, R., Blechert, J., Sheppes, G., Rydstrom, A., & Gross, J. J. (2011). The temporal dynamics of emotion regulation: an EEG study of distraction and reappraisal. *Biological psychology*, 87(1), 84-92. <http://dx.doi.org/10.1016/j.biopsycho.2011.02.009>
- Thompson, R. A. (1994). Emotion regulation: A theme in search of definition. *Monographs of the society for research in child development*, 59(2-3), 25-52. doi: 10.1111/j.1540-5834.1994.tb01276.x
- Tyang, C. M., Amin, H. U., Saad, M. N., & Malik, A. S. (2017). The influences of emotion on learning and memory. *Frontiers in psychology*, 8, 1454.  
<https://doi.org/10.3389/fpsyg.2017.01454>
- Uekermann, J., Kraemer, M., Abdel-Hamid, M., Schimmelmann, B. G., Hebebrand, J., Daum, I., ... & Kis, B. (2010). Social cognition in attention-deficit hyperactivity disorder (ADHD). *Neuroscience & biobehavioral reviews*, 34(5), 734-743.  
<https://doi.org/10.1016/j.neubiorev.2009.10.009>
- van Reekum, C. M., Johnstone, T., Urry, H. L., Thurow, M. E., Schaefer, H. S., Alexander, A. L., & Davidson, R. J. (2007). Gaze fixations predict brain activation during the voluntary regulation of picture-induced negative affect. *Neuroimage*, 36(3), 1041-1055.  
<https://doi.org/10.1016/j.neuroimage.2007.03.052>
- Urry, H. L. (2010). Seeing, thinking, and feeling: Emotion-regulating effects of gaze-directed cognitive reappraisal. *Emotion*, 10(1), 125-135. doi:10.1037/a0017434

- Wagner, D. D., Kelley, W. M., & Heatherton, T. F. (2011). Individual differences in the spontaneous recruitment of brain regions supporting mental state understanding when viewing natural social scenes. *Cerebral Cortex*, *21*(12), 2788-2796.  
<https://doi.org/10.1093/cercor/bhr074>
- Wass, S. V., Forssman, L., & Leppänen, J. (2014). Robustness and precision: How data quality may influence key dependent variables in infant eye-tracker analyses. *Infancy*, *19*(5), 427-460. <https://doi.org/10.1111/infa.12055>
- Waygood, A. (2015). *Electrical Science for Technicians*. New York, NY: Routledge.
- Webb, T. L., Miles, E., & Sheeran, P. (2012). Dealing with feeling: a meta-analysis of the effectiveness of strategies derived from the process model of emotion regulation. *Psychological bulletin*, *138*(4), 775 -808. doi:10.1037/a0027600
- Winstanley, C. A., Eagle, D. M., & Robbins, T. W. (2006). Behavioral models of impulsivity in relation to ADHD: translation between clinical and preclinical studies. *Clinical psychology review*, *26*(4), 379-395. doi: 10.1016/j.cpr.2006.01.001
- Wirth, M., Isaacowitz, D. M., & Kunzmann, U. (2017). Visual attention and emotional reactions to negative stimuli: The role of age and cognitive reappraisal. *Psychology and aging*, *32*(6), 543-556. <http://dx.doi.org/10.1037/pag0000188>
- Yang, Y. D., Allen, T., Abdullahi, S. M., Pelphrey, K. A., Volkmar, F. R., & Chapman, S. B. (2018). Neural mechanisms of behavioral change in young adults with high-functioning autism receiving virtual reality social cognition training: A pilot study. *Autism Research*. doi: 10.1002/aur.1941

- Yoon, K. L., & Zinbarg, R. E. (2008). Interpreting neutral faces as threatening is a default mode for socially anxious individuals. *Journal of abnormal psychology, 117*(3), 680-685. doi: 10.1037/0021-843X.117.3.680
- Young, S. (2005). Coping strategies used by adults with ADHD. *Personality and Individual Differences, 38*(4), 809-816. <https://doi.org/10.1016/j.paid.2004.06.005>
- Zeffirelli, F. (1979). The champ [Motion picture]. *United States: Metro-Goldwyn-Mayer (MGM)*.
- Zimmermann, P., & Iwanski, A. (2014). Emotion regulation from early adolescence to emerging adulthood and middle adulthood Age differences, gender differences, and emotion-specific developmental variations. *International Journal of Behavioral Development, 38*(2), 182-194. doi: 10.1177/0165025413515405

## APPENDICES

### Appendix A Glossary of Eye-Tracking Terms

<b>Term</b>	<b>Definition</b>
Areas of interest	Regions in the image or video outlined by the researcher that tells the eye-tracker to output specific data (e.g., fixation data that occurred within the AOI)
CURRENT_FIX_PUPIL	A measure of the pupil size in eye-tracker units during the current fixation.
Eye-gaze	Region where the participant is looking.
Fixation duration	A focal point at which an individual looks for longer than random scanning.
IA_DWELL_TIME_%	An eye-tracking output in an attentional deployment file that reports that percentage of time a participant fixates on a delineated area of interest
Mobile eye-tracker	A portable eye-tracking device that can be worn that allows the participant to move (e.g., walk) that records gaze in the environment.
Stationary eye-tracker	An eye-tracker that requires the participant to be stationary in order to record gaze.

Note. Definition of terms from De Wit, 2009, SR Research, 2016

## Appendix B

### *Frequencies of Demographic Variables for Study 1 and Study 2*

<u>Category</u>	<u>Study 1*</u>	<u>Study 2**</u>
Handedness		
Right-handed	94	90
Left-handed	6	7
Ambidextrous	0	3
Ethnicity		
White	47	58
Black	13	8
South Asian	12	6
Middle Eastern	10	9
East Asian	8	8
Other/Mixed	8	11
Hispanic	2	1
Mental Health Diagnosis		
ADHD	4	2
Mood Disorders	15	14
Took Medication Today		
Yes	19	21
No	81	80
Passed ADHD Screener		
Total Participants	33	36
Participants with ADHD	4	2
Participants with Mood Disorders	7	7
Employment		
Employed	65	72
Not employed	35	28
Parental Education		
High School	19	17
College Diploma	34	27
Bachelor's Degree	32	34
Professional Degree	10	19
Watched "The Perks of Being a Wallflower"		
Yes	56	-
No	44	-

Read “The Perks of Being a  
Wallflower”

Yes	18	-
No	82	-

Watched “The Heider-Simmel Task”

Yes	-	8
No	-	93

---

*Note.* \*N = 100; \*\*N = 101

## Appendix C

### Permissions Table

Measure	Date and Permission Authority
Adult ADHD Self-Report Scale – V1.1 (ASRS)	May 18, 2017 contact with Dr. Kessler; ASRS does not require formal permission
Barratt Impulsiveness Scale – Eleventh Edition (BIS-11)	May 18, 2017 email permission obtained by Dr. Patton.
Emotion Regulation Questionnaire (ERQ)	May 17, 2017 email permission obtained by Dr. Gross.
Immediate Memory Task (IMT)	June 1, 2017 email permission obtained by Dr. Dougherty.
“The Perks of Being a Wallflower” [motion picture]	March 14, 2017 consultation with Copyright at UWindsor. Since the total percentage of the runtime is 2.8% of the clip, intended use of the copyright protected materials falls within the bounds of Fair Dealing, and therefore does not require copyright permission.



## Appendix D

### Demographic Form

*Please answer the following questions about yourself by selecting the appropriate choice and/or using the space provided:*

Initials: \_\_\_\_\_

Current Date (month/day/year): \_\_\_\_\_

1. What is your date of birth and age?
  - a. Month and Year of Birth: \_\_\_\_\_
  - b. Age: \_\_\_\_\_
2. What is your gender: \_\_\_\_\_
3. Handedness: Right-handed    Left-handed
4. What ethnicity do you identify yourself as? \_\_\_\_\_
5. In which languages are you fluent?
  - a. English    Comprehend    Speak    Write
  - b. French    Comprehend    Speak    Write
  - c. Other language: \_\_\_\_\_ Comprehend    Speak    Write
  - d. Other language: \_\_\_\_\_ Comprehend    Speak    Write
  - e. Other language: \_\_\_\_\_ Comprehend    Speak    Write
  - f. Other language: \_\_\_\_\_ Comprehend    Speak    Write
6. What is your highest level of education completed (e.g., high school, first year of undergrad)? \_\_\_\_\_
7. What is your current program and year of enrolment?
  - a. Program: \_\_\_\_\_
  - b. Year: \_\_\_\_\_
8. Do you have any:
  - a. Visual Impairment (e.g., wear corrective lenses);  
Specify: \_\_\_\_\_
  - b. Hearing Impairment (e.g., wear hearing aid);  
Specify: \_\_\_\_\_

9. Have you received any diagnoses of mental health difficulties (i.e., ADHD, anxiety, depression)? If yes, please specify: \_\_\_\_\_  
\_\_\_\_\_
10. Have you taken any medication today (prescribed or otherwise)? If yes, please specify: \_\_\_\_\_  
\_\_\_\_\_
11. Have you taken any recreational drugs today? If yes, please specify: \_\_\_\_\_  
\_\_\_\_\_
12. Are you employed? \_\_\_\_\_
13. If employed, what is your occupation? \_\_\_\_\_
14. Highest level of parental figure 1 education: \_\_\_\_\_
15. Parental figure 1 occupation when working: \_\_\_\_\_
16. Highest level of parental figure 2 education: \_\_\_\_\_
17. Parental figure 2 occupation when working: \_\_\_\_\_
18. What is your family annual income?
- a. 70,000 or more
  - b. 60,000 to 69,999
  - c. 50,000 to 59,999
  - d. 40,000 to 49,999
  - e. 30,000 to 39,999
  - f. Below 30,000

I do not know or I do not wish to answer

## Appendix E

### Programming for Study 1 on Experiment Builder v 2.1.140

Note: Each consecutive page shows detailed programming indicated by the purple box on the previous page.

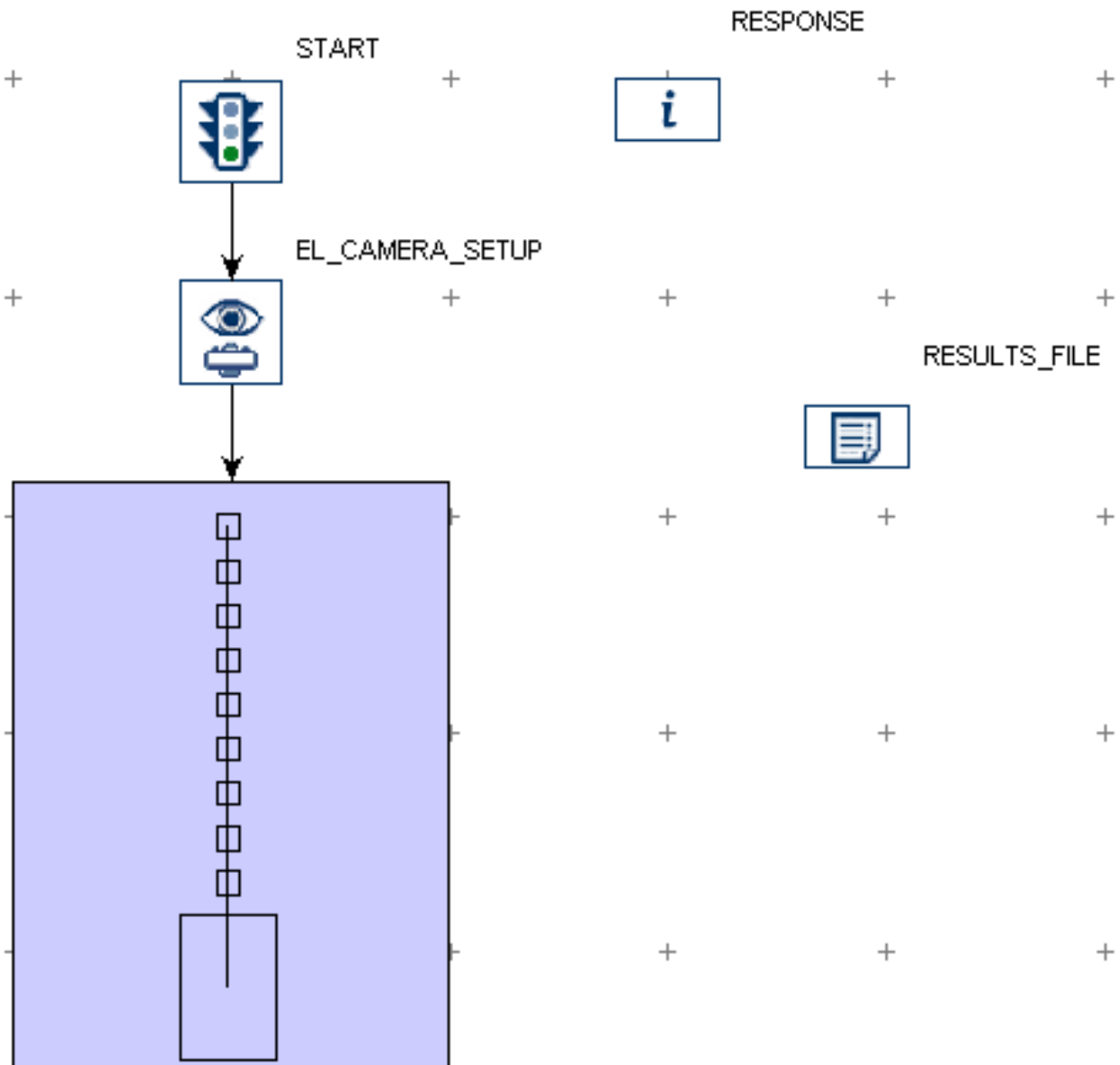

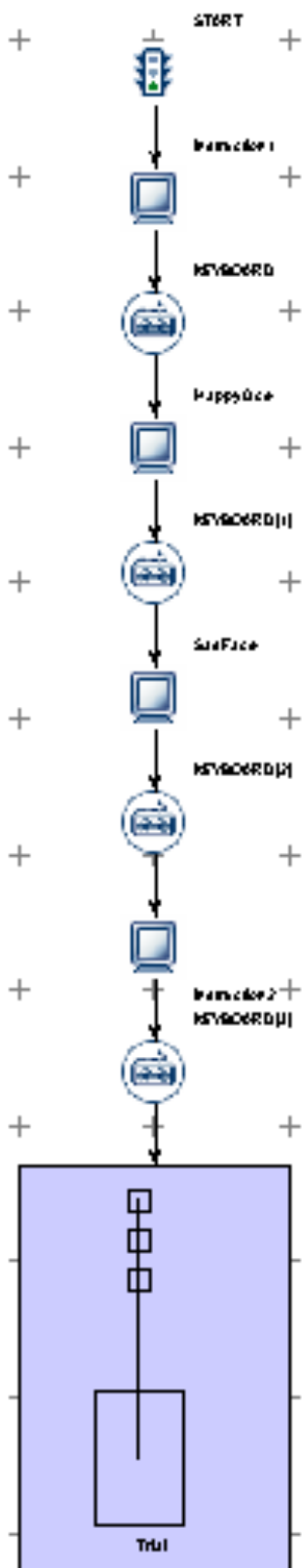

Start

Instruction 1

Keyboard (**space**)

Happy Face ☺

Keyboard (**right**)

Sad Face ☹

Keyboard (**left**)

Instruction 2

You will be viewing video clips from the film "The Perks of Being a Wallflower"

At the end of each clip, identify if you feel positive by pressing the right arrow (->) or if you feel negative by pressing the left arrow (-<).

Let's practice with some pictures. Press space to begin.

Great!

In between each clip, a screen will appear with a dot in the centre.

Please focus on the centre of the dot

Press the space bar to begin

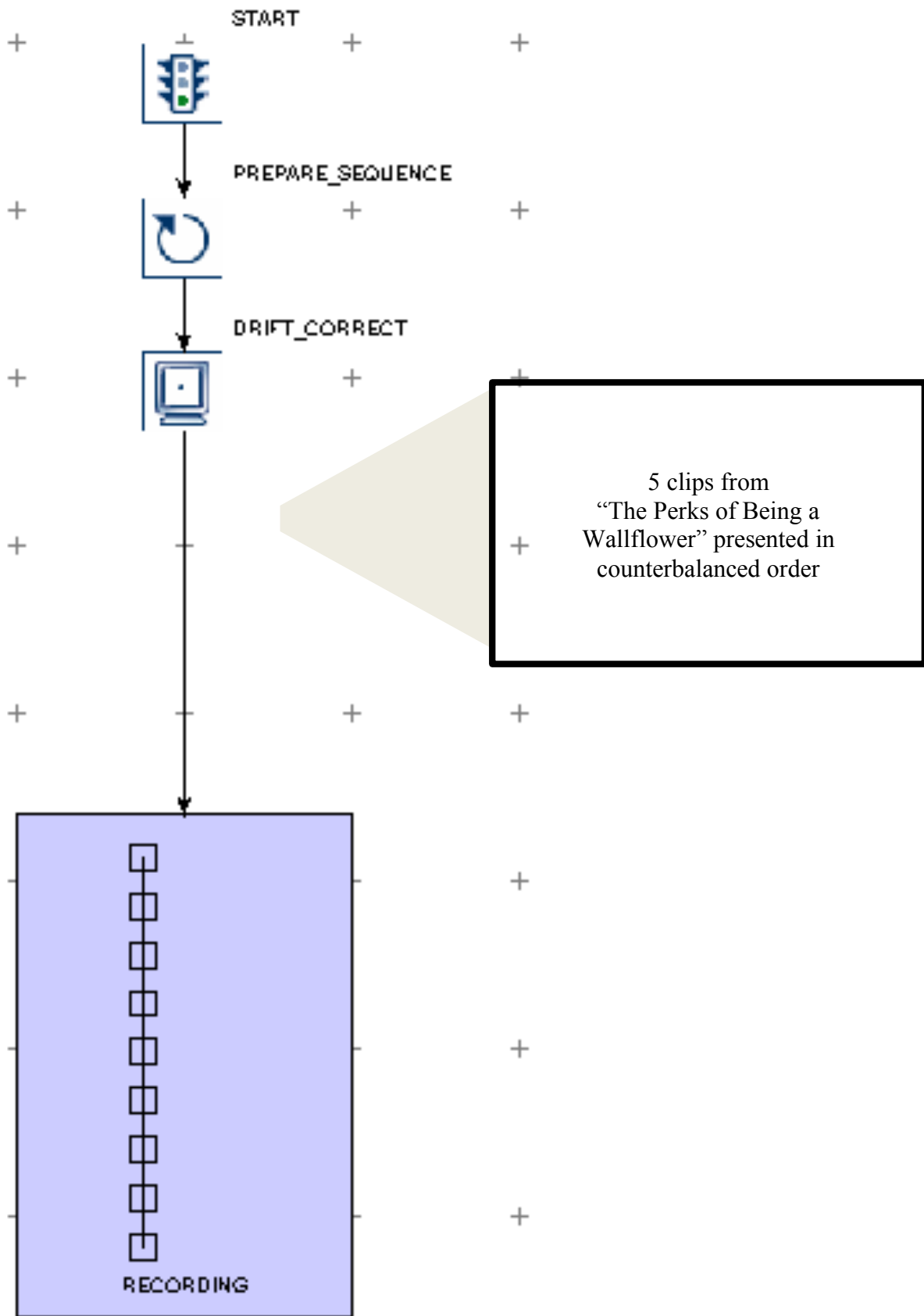

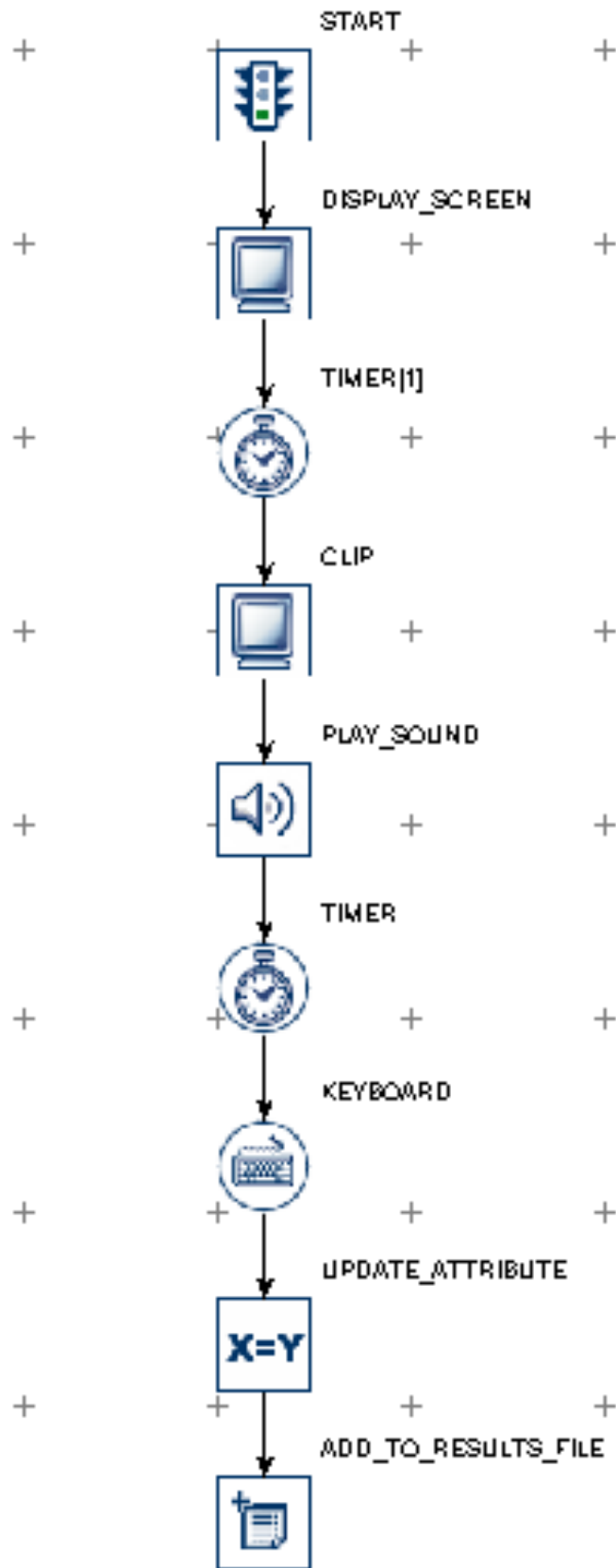

## Appendix F

Programming for Study 2 on Experiment Builder v 2.1.140

Note: Each consecutive page shows detailed programming indicated by the purple box on the previous page.

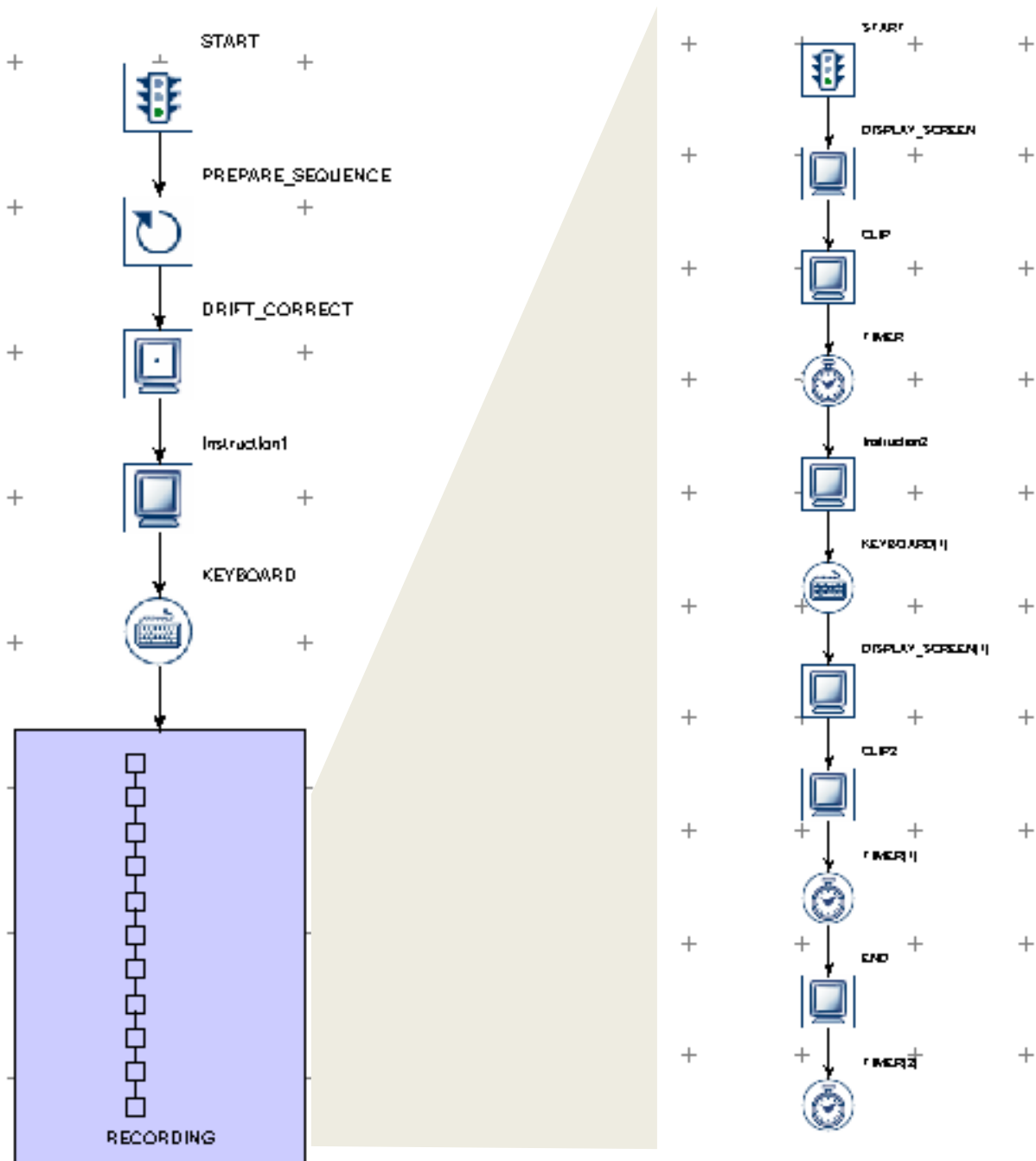

## Appendix G



### CONSENT TO PARTICIPATE IN RESEARCH

#### **TITLE OF STUDY:** Eye-Tracking Movie Clips

You are asked to participate in a research study conducted by Abirami R Kandasamy under the supervision of Dr. Julie Hakim-Larson from the Department of Psychology at the University of Windsor. The results from this study will form the basis of a PhD dissertation. If you have any questions or concerns about the research, please feel to contact Abirami Kandasamy at [kandasaa@uwindsor.ca](mailto:kandasaa@uwindsor.ca) or Dr. Julie Hakim-Larson, through email ([hakim@uwindsor.ca](mailto:hakim@uwindsor.ca)).

#### **PURPOSE OF THE STUDY**

The purpose of this study is to understand more about the visual process that occurs during the viewing of film clips as measured by eye-tracking, a computer task, and brief questionnaires.

#### **PROCEDURES**

If you volunteer to participate in this study, you will be asked to:

Meet in the room 062 in Chrysler Hall South where the research study will take place for 1 hour. You will first read and consent to the study as well as ask any questions pertaining to consent or details about the study (5 minutes). You will then complete a demographic information form (5 minutes).

##### Eye-Tracker

You will rest your face on a sterilized chin-rest and be calibrated to a computer screen on which you will view video clips (15 minutes). You will then move away from the chin-rest, which will be swabbed with alcohol, and play a memory game on a different computer (10 minutes).

##### Brief Questionnaire

Finally, you will answer a brief set of questionnaire on real-world actions and decisions that you regularly take, on your attention abilities, on how you manage stressful situations, and on how you experience and express emotions (maximum 25 minutes).

#### **POTENTIAL RISKS AND DISCOMFORTS**

In participating in this study, you may experience negative feelings as a result of watching emotionally evocative film clips. If you feel any distress after participating in this study, please contact any of the organizations named in resource list for distress centres. As well, if you feel distress and are no longer able to continue the study, you will not be penalized for stopping.

#### **POTENTIAL BENEFITS TO PARTICIPANTS AND/OR TO SOCIETY**



Completing the questionnaires may facilitate deeper understanding of yourself and how you manage emotions. Additionally, you will gain exposure to eye-tracking technology and you may gain a better understanding of research and the research process. The study will contribute to our understanding of how individuals interpret and process emotional stimuli.

### **COMPENSATION FOR PARTICIPATION**

You will receive 1.5 bonus point for 60 minutes of participation towards the psychology participant pool, if you are registered in the pool and enrolled in one or more eligible courses.

### **CONFIDENTIALITY**

Any information that is obtained in connection with this study and that can be identified with you will remain confidential and will be disclosed only with your permission. All of the information that is collected (demographic information, eye-tracking output, and questionnaire scores) will be kept private and will only be accessed by researchers directly involved with the study. The information collected will be stored in an electronic database on a secure server, which is password-protected. The data will be kept on an encrypted USB and on a secure computer in a locked office. Your name and email will be required for compensation (participant pool points) but it will be deleted once the bonus marks have been assigned and semester grades have been submitted. The information from this study may be published at a later date and may be used in future analyses, but only group information and no personally-identifying information will be discussed. In accordance with the guidelines of the American Psychological Association, your data will be kept for five years following the last publication of the data. If the data are not used for subsequent research or will not be published, the data will be destroyed.

### **PARTICIPATION AND WITHDRAWAL**

**You have the right to withdraw from this study at any point during the 1 hour allocated time and for up to 24 hours after the study has taken place, after which data will be deidentified.**

The investigator may withdraw you from this research if circumstances arise which warrant doing so. Your data (results) will be permanently deleted if you chose to withdraw within 24 hours of participating in the study but your information (name and participant ID number) will be kept in order to allocate points when appropriate. You will be allocated points in ratio to the content completed. A maximum of 1.5 points will be allocated to this study. You will receive full points for completing all of the tasks. If you complete only one of the items, a minimum of 0.5 points will be allocated (but these data will not be useable). After the data are deidentified, you will no longer be able to request that your data be withdrawn.

### **FEEDBACK OF THE RESULTS OF THIS STUDY TO THE PARTICIPANTS**

A summary of research findings will be available to you upon completion of the project on the Research Ethics Board website, <http://www1.uwindsor.ca/reb/study-results>.

Email address: Abirami Kandasamy [kandasaa@uwindsor.ca](mailto:kandasaa@uwindsor.ca)

Date when results are available: August 31, 2018

### **SUBSEQUENT USE OF DATA**

These data may be used in subsequent studies, in publications and in presentations.

**RIGHTS OF RESEARCH PARTICIPANTS**

If you have questions regarding your rights as a research participant, contact: Research Ethics Coordinator, University of Windsor, Windsor, Ontario, N9B 3P4; Telephone: 519-253-3000, ext. 3948; email: [ethics@uwindsor.ca](mailto:ethics@uwindsor.ca)

**SIGNATURE OF RESEARCH PARTICIPANT/LEGAL REPRESENTATIVE**

I understand the information provided for the study Eye-Tracking Movie Clips as described herein. My questions have been answered to my satisfaction, and I agree to participate in this study. I have been given a copy of this form.

\_\_\_\_\_  
Name of Participant

\_\_\_\_\_  
Signature of Participant

\_\_\_\_\_  
Date

**SIGNATURE OF INVESTIGATOR**

These are the terms under which I will conduct research.

\_\_\_\_\_  
Signature of Investigator

\_\_\_\_\_  
Date

## Appendix H

### Resources for Emotional Distress

Thank you for participating in this study. We are interested in studying how emotion regulation style influences what individuals with varying levels of impulsivity pay attention to. As such you viewed clips that may have caused you some emotional discomfort. Please take a look at the list of resources that is provided to you below. This list contains contact information for various community services in case you wish to contact someone to talk about emotional difficulties you may be experiencing.

#### **Student Counseling Centre, University of Windsor**

The Student Counseling Centre (SCC) provides assessment, crisis, and short term counseling. If longer term therapy is indicated, the SCC will provide a referral to the Psychological Services Centre. All services are confidential and offered free to students. The SCC is open 8:30 am – 4:30 pm, Monday – Friday. The SCC is located in Room 293, CAW Centre.

[519-253-3000](tel:519-253-3000), ext. 4616.

[scc@uwindsor.ca](mailto:scc@uwindsor.ca)

#### **Psychological Services Centre, University of Windsor**

The Psychological Services Centre offers assistance to University students in immediate distress and to those whose difficulties are of longer standing. They also seek to promote individual growth and personal enrichment.

[519-973-7012](tel:519-973-7012) or [519-253-3000](tel:519-253-3000), ext. 7012

#### **Teen Health Centre**

The Teen Health Centre is dedicated to helping Essex County's young people achieve physical and emotional health and well-being through education, counseling, and support.

[519-253-8481](tel:519-253-8481)

#### **Sexual Assault / Domestic Violence & Safekids Care Center**

This care center is located in the Windsor Regional Hospital and provides assessment, counseling, and treatment for domestic violence, sexual assault, and child abuse. It is open 8 am to 4 pm, Monday – Friday or 24 hours, 7 days a week through the hospital emergency services.

[519-255-2234](tel:519-255-2234)

#### **Hiatus House**

Hiatus House is a social service agency offering confidential intervention for families experiencing domestic violence.

[519-252-7781](tel:519-252-7781) or [1-800-265-5142](tel:1-800-265-5142)

#### **Distress Centre Line Windsor / Essex**

The Distress Centre of Windsor-Essex County exists to provide emergency crisis intervention, suicide prevention, emotional support and referrals to community resources by telephone, to people in Windsor and the surrounding area. Available 12 pm to 12 am seven days a week.

[519-256-5000](tel:519-256-5000)

**Community Crisis Centre of Windsor-Essex County**

A partnership of hospital and social agencies committed to providing crisis response services to residents of Windsor and Essex counties. Crisis center is open from 9 am to 5 pm, Monday – Friday, at Hotel-Dieu Grace Hospital in Windsor, ON.

[519-973-4411](tel:519-973-4411) ext. 3277

**24 Hour Crisis Line**

24 Hour crisis telephone line provides an anonymous, confidential service from 12 pm to 12 am seven days a week. The 24 Hour Crisis Line serves Windsor and Leamington areas.

[519-973-4435](tel:519-973-4435)

**Assaulted Women’s Helpline**

The Assaulted Women’s Helpline offers 24-hour telephone and TTY crisis line for abused women in Ontario. This service is anonymous and confidential and is provided in up to 154 languages.

[1-866-863-0511](tel:1-866-863-0511) or [1-866-863-7868](tel:1-866-863-7868) (TTY)

**Neighbours, Friends, & Family**

Neighbours, Friends, and Families is a public education campaign to raise awareness of the signs of woman abuse so that those close to an at-risk woman or an abusive man can help.

<http://www.neighboursfriendsandfamilies.ca/index.php>

## Appendix I

### Character Labels for the Social Attribution Task

Please label the objects in the story:



---



---



---



---

## VITA AUCTORIS

NAME: Abirami Ravichakaravarthy Kandasamy

PLACE OF BIRTH: Montreal, QC

YEAR OF BIRTH: 1987

EDUCATION: Middlefield Collegiate Institute, Markham, ON,  
2005  
University of Western Ontario, B.Sc., London,  
ON, 2009  
York University, H.B.Sc., Toronto, ON, 2012  
University of Windsor, M.A., Windsor, ON, 2015