

3-26-2012

# State-Perpetrated Wartime Sexual Violence in Latin America

Michele Leiby

Follow this and additional works at: [https://digitalrepository.unm.edu/pols\\_etds](https://digitalrepository.unm.edu/pols_etds)

---

## Recommended Citation

Leiby, Michele. "State-Perpetrated Wartime Sexual Violence in Latin America." (2012). [https://digitalrepository.unm.edu/pols\\_etds/](https://digitalrepository.unm.edu/pols_etds/)  
4

This Dissertation is brought to you for free and open access by the Electronic Theses and Dissertations at UNM Digital Repository. It has been accepted for inclusion in Political Science ETDs by an authorized administrator of UNM Digital Repository. For more information, please contact [disc@unm.edu](mailto:disc@unm.edu).

Michele Leiby

*Candidate*

---

Political Science

*Department*

---

This dissertation is approved, and it is acceptable in quality and form for publication:

*Approved by the Dissertation Committee:*

Christopher K. Butler , Chairperson

---

William D. Stanley , Chairperson

---

Kathryn Hochstetler

---

Elisabeth Wood

---

---

---

---

---

---

---

---

**STATE-PERPETRATED WARTIME SEXUAL VIOLENCE IN  
LATIN AMERICA**

**by**

**MICHELE LEIBY**

B.A., Political Science and Spanish, Moravian College, 2002

M.A., Political Science, University of New Mexico, 2004

DISSERTATION

Submitted in Partial Fulfillment of the  
Requirements for the Degree of

**Doctor of Philosophy**

**Political Science**

The University of New Mexico  
Albuquerque, New Mexico

**July, 2011**

**© 2011, Michele Leiby**

## **DEDICATION**

This dissertation is dedicated to the victims and survivors of political violence in Peru and El Salvador. With courage, you told your stories. I consider it a great privilege and responsibility to represent those stories here. I hope that my work serves to honor your lives and memories.

## ACKNOWLEDGEMENTS

It takes a village. I would like to take a moment to recognize those without whom this project would have been impossible. First and foremost, a very special thanks is due to the members of my committee – Christopher Butler and William Stanley of the University of New Mexico, Kathryn Hochstetler of the University of Waterloo and Elisabeth Wood of Yale University – each of whom has offered years of support and guidance. This dissertation has benefited greatly from their critical insights and wisdom. To Chris, Bill, Kathy and Libby: I consider it an honor to have had the opportunity to work with each of you and to observe the rigor and integrity with which you each approach your own research. Moving forward, I strive to emulate the example you have put forward.

Beyond the committee, I have had the fortune to work with a group of world-class scholars: Patrick Ball, Dara Cohen, Scott Gates, Francisco Gutierrez, Amelia Hoover Green, Meghan Lynch and Ragnhild Nordås. Our brainstorming sessions have taught me so much and have made me a better academic.

I am grateful to those individuals and institutions that believed and invested in this project: Elisabeth Wood of Yale University, the Latin American and Iberian Institute, the Feminist Research Institute, the Graduate and Professional Students Association and the Dean of Graduate Studies at the University of New Mexico. Without your financial support, this dissertation and the almost two years of international travel it required, would not have been possible. Thank you.

I owe a great debt to the human rights leaders, policymakers and scholars in El Salvador, Peru and the United States who lent their time, their experiences and

their voice to this project. A special note of thanks is due to Ruth Borja and Karina Fernandez of the Centro de Información para la Memoria Colectiva y de los Derechos Humanos in Lima, Peru; and to Bruce Montgomery, David Hays and Yolanda Maloney of the University of Colorado, Archives Department. I am equally indebted to the brilliant team of research assistants with whom I worked – César Neruña, Doris Leon Gabriel, Ronald Fernandez Contreras, Erika Liseth Murcia, Gabriel Salazar Borja, José Rafael Bucheli Penafiel, Nanda Hazel-Ruiz Jones and Monica Asencio. Every day, they demonstrated a level of dedication and work ethic worthy of exclamation.

I am thankful to my inter-continental “family” of dear friends who have offered their love and support to Andrew and me over the past nine years. To Chris, Karin, Elora, Connor, Beth and Chuck Butler: I am touched by your generosity and kindness. In my absence, you gave Andrew a home away from home, fully equipped with a healthy helping of leafy greens. We will both miss family dinner night. To Marie Manrique: your friendship has enriched my life in so many ways.

Finally, to Andrew Mingione, who is my partner in life. Together, we have traveled tens of thousands of miles and created countless memories. There is no one else with whom I would have wanted to share this experience. I look forward to the next chapter.

# STATE-PERPETRATED WARTIME SEXUAL VIOLENCE IN LATIN AMERICA

by

**Michele Leiby**

**B.A. Political Science and Spanish, Moravian College, 2002**

**M.A. Political Science, University of New Mexico, 2004**

**PhD. Political Science, University of New Mexico, 2011**

## ABSTRACT

This dissertation examines the patterns and motives of state-perpetrated wartime sexual violence in Peru and El Salvador. Using a new database on sexual and other forms of political violence, it documents the prevalence and the patterns of perpetration of violence. It seeks to determine whose interests motivate the commission of sexual violence in times of war *and* why state armed forces commit more sexual violence in some regions and at particular moments during civil war than in others.

The dissertation provides a theory of sexual violence perpetrated by state militaries during counterinsurgency conflicts. It argues that sexual violence is a deliberate act of violence perpetrated to advance the politico-military goals of the state. The results of a sub-national statistical analysis show that state-perpetrated sexual violence is most at times and in locations where rebel activity presents a threat to state power *but* where the rebels have not yet reached dominance. State-perpetrated sexual violence is infrequent in areas where the state retains control as well as in areas where there is a preponderance of rebel power such that the state



cannot engage in counterinsurgency operations without risking a significant loss of life.

Additional explanatory power is drawn from an analysis of the micro-patterns of state sexual violence and other forms of political violence in Peru and El Salvador. Victims of sexual violence are more likely to be educated women from urban centers who are socially or politically active in their communities. In addition, sexual violence is more likely to be perpetrated in private spaces and in state-run detention centers when commanding officers are present than other forms of political violence. Within the state armed forces, the army and police are more likely to engage in these forms of violence than other sectors of the security apparatus. Paramilitary groups and death squads are less likely to engage in sexual violence than they are to perpetrate other forms of violence, particularly lethal violence. The preponderance of evidence presented in the dissertation demonstrates that sexual violence is often an instrumental weapon of war wielded to defeat armed and unarmed opponents to the state.

## TABLE OF CONTENTS

<b>List of Tables and Figures</b> .....	<b>xii</b>
<b>List of Acronyms</b> .....	<b>xvi</b>
<b>Chapter 1: Introduction</b> .....	<b>1</b>
Candidate Theories of Wartime Sexual Violence .....	3
Case Selection and Justification .....	11
Data .....	13
Organization of the Dissertation .....	15
<b>Chapter 2: Towards a Theory of Wartime Sexual Violence in Counterinsurgency Wars</b> .....	<b>18</b>
Whose Interests? Principals, Agents and Wartime Sexual Violence.....	19
Opportunity Model.....	21
Evidence Regarding Opportunity Model of Wartime Sexual Violence .....	24
State Strategy Model.....	32
Conclusion.....	43
<b>Chapter 3: Data on Wartime Sexual</b> .....	<b>45</b>
Data Availability and Victim Underreporting.....	45
What is Sexual Violence: Legal Statutes and Social Norms.....	49
Creating Analytical Concepts .....	59
Who Counts: Estimating the Number of Sexual Violence Victims .....	66
Data Used in this Study .....	70
El Salvador .....	70
Potential Biases in the Data .....	76
Peru .....	78
Potential Biases in the Data .....	82
Research Team and Inter-Coder Reliability .....	85
Introducing a New Database on Political and Sexual Violence in Peru and El Salvador.....	87
Conclusion.....	88
<b>Part I: Wartime Sexual Violence in Peru, 1980-2000</b> .....	<b>90</b>
<b>Chapter 4: Manchay Tiempo (Time of Fear): The Peruvian Civil War</b> .....	<b>91</b>
Introduction .....	91
The Emergence of the Shining Path and the “People’s War” .....	94
The State Response: National Security and Counterinsurgency .....	104
Quién Habla es Terrorista (He Who Speaks is a Terrorist): Identifying and Framing the Opposition .....	107

Política del Avestruz (A Policy of Ostrich): Belaúnde’s Missing Counterinsurgency Strategy.....	112
Great Expectations: Alan García’s Promise of Change .....	118
La Mano Dura (The Hard Hand) of Alberto Fujimori .....	124
Conclusion.....	132
<b>Chapter 5: Wartime Sexual Violence in Peru: An Analysis of Sub-National Variation .....</b>	<b>138</b>
Introduction .....	138
Data and Collection Procedures.....	138
Methods.....	148
Findings.....	150
Discussion of Outliers and Controls.....	155
Conclusion.....	161
<b>Chapter 6: Principals, Agents and State-Perpetrated Sexual Violence in Peru: An Analysis of Micro Patterns.....</b>	<b>163</b>
Introduction .....	163
Data and Methods .....	164
Repertoires of State-Perpetrated Violence during the Civil War in Peru.....	165
Victim Profile .....	172
Perpetrator Profile .....	184
Conclusion.....	193
<b>Part II: Wartime Sexual Violence in El Salvador, 1978-1992 .....</b>	<b>195</b>
<b>Chapter 7: Principals, Agents and State-Perpetrated Sexual Violence in El Salvador: An Analysis of Micro Patterns .....</b>	<b>196</b>
Introduction .....	196
The Civil War in El Salvador, 1978-1992.....	197
The Debated Prevalence of Wartime Sexual Violence in El Salvador.....	199
Data Collection and Procedures.....	210
Repertoires of State Violence during the Civil War in El Salvador.....	211
Victim Profile .....	218
Perpetrator Profile .....	229
Qualitative Patterns of Sexual Abuse by State Armed Forces.....	237
Sexual Violence in Rural Communities.....	237
Sexual Violence in State-Run Detention Centers.....	243
Conclusion.....	247
<b>Chapter 8: Conclusion.....</b>	<b>250</b>
Measures to Prevent Wartime Sexual Violence by State Militaries .....	255
<b>Appendices.....</b>	<b>258</b>
Appendix A: Guide to Collections of Archived Human Rights Documents in Peru and El Salvador.....	259

Appendix B: Intake Forms from Socorro Jurídico Cristiano and Tutela Legal del Arzobispado, El Salvador .....	263
Appendix C: Intake Forms from the Comisión para la Verdad y Reconciliación, Peru .....	266
Appendix D: Codebook on Human Rights Violations and Violent Events in Peru and El Salvador.....	276
Appendix E: Model Variations .....	285
Appendix F: Agenda for Future Research in El Salvador .....	287
<b>References .....</b>	<b>290</b>

## LIST OF TABLES AND FIGURES

### TABLES

1.1 Case Selection .....	13
2.1 Model of Wartime Sexual Violence as Opportunistic Violence: Observable Implications and Literature .....	32
2.2 Model of Wartime Sexual Violence as a Method of Counterinsurgency Warfare.....	42
3.1 Comparison of Human Rights Reporting Institutions in Peru and El Salvador ....	85
4.1 Peru in Figures: Evidence of a Divided Society .....	94
4.2 The Peruvian Civil War: Key Facts and Figures .....	96
4.3 Political Leadership and Regimes in Peru, 1962 to Present.....	134
4.4 The Evolution of Anti-Terrorism Legislation in Peru, 1981-1994 .....	137
5.1 Summary Statistics of Variables .....	146
5.2 Correlation Matrix .....	147
5.3 Results, Negative Binomial Regression with Squared Terms.....	154
5.4 Results, Negative Binomial Regression Dropping Significant Outliers.....	156
6.1 State-Perpetrated Sexual Violence, All Sexual Violations and ICC Violations Compared.....	172
6.2 State-Perpetrated Sexual Violence, Victims of All Sexual Violations and Victims of ICC Violations Compared.....	183
6.3 State Armed Forces in Peru .....	189
6.4 State-Perpetrated Sexual Violence, Perpetrators of All Sexual Violations and Perpetrators of ICC Violations Compared.....	193
7.1 Literature on Wartime Sexual Violence in El Salvador: Key Findings to Date....	200
7.2 Interviews with Governmental and Non-Governmental Institutions in El Salvador .....	210

7.3 State-Perpetrated Sexual Violence, All Sexual Violations and ICC Violations Compared.....	218
7.4 State-Perpetrated Sexual Violence, Victims of All Sexual Violations and Victims of ICC Violations Compared.....	229
E.1 Results, Negative Binomial Regression without Squared Terms.....	285
E.2 Results, Negative Binomial Regression with Restricted Dependent Variable Using ICC Definition of Sexual Violence.....	285

FIGURES

1.1 Sexual Violence in International and Civil Wars, 1940-2010 .....	1
2.1 Expected Relationship between Rebel Activity and State-Perpetrated Sexual Violence.....	41
4.1 Villa El Salvador .....	101
4.2 Shining Path Attacks and Political Assassinations.....	102
4.3 Defining and Framing Terrorism, Selected Statements .....	110
4.4 Assessment of the Strength and Threat of the Shining Path .....	113
5.1 State-Perpetrated Sexual Violence during the Peruvian Civil War, 1980-2000	140
5.2 State Repression during the Civil War in Peru, 1980-2000.....	142
5.3 State-Perpetrated Sexual and Other Forms of Political Violence during the Peruvian Civil War, 1980-2002 .....	143
5.4 Ratio of Sexual to Other Forms of Political Violence, per 100,000 People, by Department .....	144
5.5 A Linear Fit and the True Quadratic Relationship with Simulated Data.....	150
5.6 Predicted Frequency of State-Perpetrated Sexual Violence Given Observed Frequency of Shining Path Activity.....	152
6.1 and 6.2 State-Perpetrated Political and Sexual Violence in Peru, 1980-2002....	171
6.3-7.60 Demographic Profile of Victims of State-Perpetrated Sexual and Other Types of Political Violence in Peru.....	183

6.11 Repertoires of Violence by State Armed Groups .....	190
6.12 Repertoires of Violence by Non-State Armed Groups .....	190
6.13 Sexual Violence by State Armed Groups.....	191
6.14 Sexual Violence by Non-State Armed Groups .....	191
7.1 Beatings to the Testicles with One’s Closed Fists, Knees or a Foreign Instrument.....	204
7.2 Electric Shock Applied to Various Parts of the Body, Including the Ears, Nipples, Tongue, Penis, Anus and Feet.....	205
7.3 Forced Nudity, a State of Complete Helplessness in which the Prisoner May be Subjected to Sexual Harassment or Humiliation and is Exposed to the Elements...	205
7.4 and 7.5 Rape and Threats of Rape .....	205
7.6 Other Forms of Sexual Torture.....	206
7.7 State-Perpetrated Political Violence in El Salvador, 1978-1992 .....	213
7.8 Types of State-Perpetrated Sexual Violence in El Salvador .....	216
7.9 State-Perpetrated Sexual and Other Forms of Political Violence in El Salvador, 1978-1992 .....	217
7.10 Ad Placed by COPREFA in the Salvadoran Daily, <i>El Mundo</i> 30 July 1988 .....	220
7.11 Ad Placed by the National Information Services in the Salvadoran Daily, <i>El Mundo</i> 12 July 1989.....	221
7.12 State Propaganda Pamphlet No. 1 .....	222
7.13 State Propaganda Pamphlet No. 2.....	222
7.14-7.18 Profile of Victims of State-Perpetrated Sexual and Other Forms of Political Violence .....	228
7.19 Sexual and Other Forms of Political Violence Perpetrated by State Security Agents .....	231
7.20 Repertoires of State Violence by Perpetrator Group .....	231

7.21 Sexual and Other Forms of Political Violence Perpetrated by the FMLN.....	232
7.22 Types of State-Perpetrated Sexual Violence by Perpetrator Group.....	234
7.23 El Mozote, Morazán .....	238
7.24 Church in El Mozote, Morazán .....	239
7.25 The Hills Behind the Church in El Mozote, Morazán.....	239



## LIST OF ACRONYMS

### GENERAL

AI	Amnesty International
ANC	African National Congress
FARC	Fuerzas Armadas Revolucionarias de Colombia (Revolutionary Armed Forces of Colombia)
FBIS	Foreign Broadcast Information Service
FSLN	Frente Sandinista de Liberación Nacional (Sandinista National Liberation Front)
GDP	Gross Domestic Product
GNI	Gross National Income
HRW	Human Rights Watch
IACHR	Inter-American Commission on Human Rights
ICC	International Criminal Court
ICRC	International Committee of the Red Cross
IDF	Israel Defense Force
FOIA	Freedom of Information Act
LTTE	Liberation Tigers of Tamil Eelam
NSA	National Security Archives
OAS	Organization of American States
PTSD	Post-Traumatic Stress Disorder
RUF	Revolutionary United Front
SV	Sexual Violence
UN	United Nations
UNSC	United Nations Security Council
WTO	World Trade Organization

### EL SALVADOR

AGEUS	Asociación General de Estudiantes Universitarios Salvadoreños (General Association of Salvadoran University Students)
ANDES	Asociación Nacional de Educadores Salvadoreños (National Association of Salvadoran Educators)
CDHES	Comisión de los Derechos Humanos de El Salvador (Human Rights Commission of El Salvador)
COPREFA	Comité de la Prensa de las Fuerzas Armadas (Salvadoran Armed Forces Press Committee)
COMADRES	Comité de las Madres de los Desaparecidos (Committee of the Mothers of the Disappeared)
CVES	Comisión para la Verdad de El Salvador
FAL	Fuerza Armada de la Liberación (Armed Liberation Forces)
FMLN	Frente Farabundo Martí para la Liberación Nacional (Farabundo Martí National Liberation Front)
FPL	Fuerzas Populares de la Liberación (Popular Liberation Front)
GN	Guardia Nacional (National Guard)

IDHUCA	Instituto de los Derechos Humanos de la Universidad Centroamericana (Institute of Human Rights at the University of Central America)
MERS	Movimiento Estudiantil Revolucionario (Revolutionary Student Movement)
PH	Policía d Hacienda (Treasury Police)
PN	Policía Nacional
SJC	Socorro Jurídico Cristiano (Christian Legal Aid)
UNTS	Union Nacional de los Trabajadores Salvadoreños (National Union of Salvadoran Workers)

#### PERU

APRA	Alianza Popular Revolucionaria Americana (American Popular Revolutionary Alliance)
BDCVR	Base de Datos de la Comisión para la Verdad y Reconciliación (Database of the Truth and Reconciliation Commission)
CAD	Comités de Autodefensa (Self-Defense Committees)
CAEM	Centro de Altos Estudios Militares (Center of High Military Studies)
CCFFAA	Comando Conjunto de las Fuerzas Armadas (Joint Command of the Armed Forces of Peru)
CGTP	Confederación General de Trabajadores del Perú (General Confederation of Peruvian Workers)
CIMCDH	Centro de Información para la Memoria Colectiva y de los Derechos Humanos (Center for Information for Collective Memory and Human Rights)
CVR	Comisión para la Verdad y Reconciliación (Truth and Reconciliation Commission)
DINCOTE/ DIRCOTE	Dirección Contra el Terrorismo (Counter-Terrorism Directorate)
DL	Decreto Legislativo (Legislative Decree)
EP	Ejército Peruano (Peruvian Army)
FEPOMUVES	Federación Popular de Mujeres de Villa El Salvador (Popular Federation of Women from Villa El Salvador)
FFAA	Fuerzas Armadas de el Perú (Armed Forces of Peru)
GC	Guardia Civil (Civil Guard)
GEIN	Grupo Especial de Inteligencia (Special Intelligence Group)
GR	Guardia Republicana (Republican Guard)
GOP-UL	Grupo de Opinión Pública-Universidad de Lima (Public Opinion Group at the University of Lima)
IOP-PUCP	Instituto de Opinión Pública-Pontifica Universidad Católica del Perú (Institute of Public Opinion-Pontifical Catholic University of Peru)
IU	Izquierda Unida (United Left)
MRTA	Movimiento Revolucionario Túpac Amaru (Tupac Amaru Revolutionary Movement)
PCP-SL	Partido Comunista del Peru-Sendero Luminoso (Communist Party of

	Peru-Shining Path)
PPD	Partido Popular Democrático (Popular Democratic Party)
PIP	Policía Investigativa de Perú (Peruvian Investigative Police)
PNP	Policía Nacional de Perú (Peruvian National Police)
SANAF	Compañía de Servicio Activo No Acuartelado Femenino (Women's Reserve Company)
SIN	Servicio de Inteligencia Nacional (National Intelligence Service)
SINAMOS	Sistema Nacional de Apoyo a la Movilización Social (National System for Support of Social Mobilization)
SUAT	Subunidad de Acciones Tácticas (Tactical Unit)
UNE	Universidad Nacional de Educación Enrique Guzmán y Valle (Enrique Guzmán y Valle National University for Education, also known as La Cantuta)

# CHAPTER 1

## INTRODUCTION

Wartime sexual violence has been called one of the most appalling human rights abuses. The media continues to report of its occurrence in conflicts around the world, most recently during the government's repression of democratic protestors in Libya and during the civil wars in Sudan and the Democratic Republic of Congo.<sup>1</sup>



**Figure 1.1 Sexual Violence in International and Civil Wars, 1940-2010 (based on information from Cohen 2010, Green 2006 and Wood 2006).**

Despite the onslaught of media coverage within the last five years, wartime sexual violence is not a new phenomenon. It has been documented in both inter-state and intra-state wars throughout history. However, as some scholars have demonstrated, sexual violence is not inevitable in times of war (Cohen 2010, Wood 2006 and 2009). For every

---

<sup>1</sup> The International Criminal Court (ICC) has recently opened investigations into the rape of women by officers at security checkpoints and roadblocks in Libya (Moreno-Ocampo 2011).

conflict in which sexual violence appears widespread, there is another in which sexual violence is paradoxically absent or infrequent.

In addition, many armed groups do not engage in sexual violence. Even those that commit other human rights abuses and frequently violate the laws of war do not always engage in sexual violence. Groups such as the Shining Path in Peru, the Tamil Tigers in Sri Lanka and the Israeli Defense Forces (IDF) appear to refrain from sexual violence, despite broad repertoires of violence that include kidnapping, political assassination, massacres and torture (Wood 2006).

Lastly, there are also significant variations in the form and patterns of sexual violence in war. During the genocide in Rwanda, for instance, countless women and young girls were raped and gang raped by the *interahamwe* before being murdered alongside their husbands and brothers (Sharlach 2001). In the former Yugoslavia, women were often held in so-called rape camps, where they were repeatedly assaulted and forcibly impregnated (Stiglmayer 1994). Quite disparately, during the so-called dirty wars in Argentina and Chile, state security officials were known to use electricity, insects and rodents to sexually torture both male and female political prisoners (Bunster-Burotto 1986).

The political science literature on wartime sexual violence is new. As such, there remain a number of unanswered questions about where, when and how sexual violence is perpetrated in times of war. The most promising work has begun to focus on explaining the variation in the frequency and patterns of sexual violence: *why does sexual violence occur in some wars but not in others* (Cohen 2010, Wood 2006); *why do some armed groups perpetrate sexual violence while others appear to refrain from such criminal*

*behavior* (Wood 2009 and 2010)? This dissertation contributes to the literature by examining the sub-national variation in the frequency and patterns of state-perpetrated sexual violence during the civil wars in Peru and El Salvador. It is motivated by two research questions: (1) why do state armed forces commit more sexual violence in some regions and at particular moments during civil war than in others?; and (2) whose interests motivate the commission of sexual violence in times of war? Answering these questions will contribute to our collective understanding of the causes of wartime sexual violence and, in turn, help us to identify policies and programs that can address the needs of affected populations as well as prevent future sexual abuse in conflict situations.

In the section below, I will briefly discuss the theoretical literature on wartime sexual violence, the gaps therein and how this study proposes to build off of earlier research.

### **Candidate Theories of Wartime Sexual Violence**

One of the first theories of wartime sexual violence to emerge in the literature argued that rape was more likely to occur in conflicts fought along ethnic lines than those that are not (Bloom n.d., Plumper and Neumayer 2006, Sharlach 1999 and 2000). Secessionist conflicts, in which one or more ethnic groups seek to partition a territory to establish a homogenous nation-state, are believed to be at particular risk for widespread sexual violence (Hayden 2000). This theory was generated from the observations of widespread sexual violence during the civil wars in the former Yugoslavia and Rwanda in the early 1990s. In some cases, sexual violence, particularly rape, forced pregnancy and forced abortion, can be weapons used to perpetrate genocide by altering the reproductive capacity of an ethnic group. In other cases, sexual violence (and the fear of

being raped by someone of another ethnicity) can be used to terrorize local communities and ethnically cleanse a territory. Exploiting ethnic tensions and stereotypes, the fear or threat of being raped by someone of another ethnic group can be sufficient to cause a mass exodus of people from their homes and land (Farr 2009).

Research on the conflicts in the former Yugoslavia and Rwanda has been important to the development of an academic and policy agenda on wartime sexual violence. Analyses of sexual violence in these wars has contributed to our understanding of the causes and consequences of such violence and has led to the establishment of international legal precedent on sexual violence in conflict situations. However, this theoretical model cannot explain why sexual violence occurs in some ethnic conflicts but not in others. Scholars have noted the relative absence of sexual violence during the secessionist ethnic war in Sri Lanka (Wood 2006). Nor can it account for the frequent sexual abuses that occur in non-ethnic wars, such as that in Sierra Leone (Cohen 2010). Even in conflicts purported to be driven by ethnic tensions, sexual violence may not be perpetrated as *ethnic* violence and may not be targeted against members of a particular ethnic group. Based on interviews conducted in the Democratic Republic of Congo, Eriksson Baaz and Stern (2010) have noted that despite the multiple ethno-nationalist cleavages within the civil war, ethnic or racial identities are rarely cited as motivating factors in the commission of sexual violence (14). As the number of studies on wartime sexual violence has increased, it has become apparent that the “ethnic hatred” argument is only one piece of the puzzle.

Drawing on feminist theories of violence and power, others have argued that wartime sexual violence is a manifestation of “peacetime” gender-based inequalities and

violence. Accordingly, sexual violence is viewed as an expression of male aggression that is perpetrated (almost) exclusively against women (Brownmiller 1975). Violence against women is understood as a continuum in which domestic violence, rape in times of “peace,” honor killings and wartime sexual violence are related (Cockburn 2002). Rape is “an act of dominance over women that works systematically to maintain a gender-stratified society in which women occupy a disadvantaged status as the appropriate victims and targets of sexual aggression” (MacKinnon 1991). As women’s rights become recognized and social, political and economic equality between the genders is achieved, wartime sexual violence should decline.

One variant of this argument, drawing specifically on liberal feminism, suggests that as women are incorporated into the world’s armies, the prevalence of wartime sexual violence will decline. More specifically, those groups in which women comprise a significant proportion of members will refrain from the use of sexual violence during conflict either because they do not have to rape civilians due to the availability of female cadre with whom to have consensual or nonconsensual sexual relations *or* because the presence of women has a pacifying effect on the behavior of male combatants, reminding them of the illegitimacy of such acts. The occurrence of “blue on blue” rape within the US military, which has been described as “rampant” and an “epidemic” could suggest that servicemen simply turn their misogynistic aggressions toward their female peers instead of raping civilians in the theatre of war (Firestone and Harris 1994, Gibbs 2010, Marshall 2008, Morris 1996, Nelson 2002).

The empirical evidence to support the claim that armed groups with a significant percentage of female militants are less likely to engage in sexual abuses is mixed, at best.



The IDF, which not only includes women in its ground, air and naval forces, but also allows for women to serve in active combat roles, has refrained from the widespread use of sexual violence against civilians and opposition forces during the Israeli-Palestinian conflict (Wood 2006). The absence of sexual violence in this conflict is notable given the duration of the conflict, the apparent intractability of ethnic and religious differences between the two countries, and most importantly, the IDF's propensity to engage in other forms of violence against civilians. Similarly, women have joined rebel movements in El Salvador (the *Frente Farabundo Martí para Liberación Nacional*, FMLN Farabundo Marti National Liberation Front), Nicaragua (the *Frente Sandinista de la Liberación Nacional*, FSLN, the Sandinista National Liberation Front), Sri Lanka (the Liberation Tigers of Tamil Eelam, LTTE), South Africa (the African National Congress, ANC) and Peru (the *Movimiento Revolucionario Túpac Amaru*, MRTA Tupac Amaru Revolutionary Movement), among others. None of these groups is reported to have engaged in frequent sexual abuse.

On the other hand, women also participated actively in the *Fuerzas Armadas Revolucionarias de Colombia* (FARC, Revolutionary Armed Forces of Colombia), the Lord's Resistance Army in Uganda, and the Revolutionary United Front in Sierra Leone, all of which have been charged with committing acts of sexual violence in conflict zones (Carlson and Mazurana 2008, Cohen 2008, Wood 2010).

The incorporation of women into the state militaries in Latin America did not begin in large part until the 1980s. Even then, it was a long and difficult process, and did not occur uniformly across divisions in the armed forces. For example, in 1996, the Peruvian Congress mandated all military institutions – the Army, Air Force and Navy –

to permit the incorporation of women into their ranks (the law went into effect in 1998).<sup>2</sup> Women can advance to the highest rank. However, they are often restricted to particular areas of service. In no branch of the armed services are women allowed to serve in combat zones or in special operations forces. In the Army, women are additionally restricted to the fields of engineering, communications, and providing support services, such as delivering food and fuel to combat units. Women in the Navy are prohibited from serving on submarines. As late as 2007, women comprised only 2 percent of all members of the armed forces in Peru (1.9 percent in the Air Force, 1.9 percent in the Army, and 2.1 percent in the Navy) (Escobar n.d.).<sup>3</sup> In neither El Salvador nor Peru is there significant variation in the number of women serving in different branches of the state armed forces. Moreover, those units with the least number of women, namely special operations forces and paramilitary groups are not more likely to perpetrate sexual violence than the regular police and army where women serve in greater numbers (see Chapters 4 and 7).

Moreover, this theoretical position is problematic because it essentializes gender roles during war by assuming that men are always the perpetrators and women are always the victims of sexual violence. Neither claim is empirically valid. Evidence suggests that female combatants are often witnesses to, facilitators of, and/or active participants in grave human rights violations, including sexual abuse. Both US servicemen *and* servicewomen have reportedly committed acts of sexual violence during the “Global War

---

<sup>2</sup> Of course, the service of women in various support capacities, prior to 1998, should be recognized. Historically, women have aided the military through the *Compañía de Servicio Activo No Acuartelado Femenino* (SANAF, Women’s Reserve Company), where they served administrative or auxiliary functions for the Army. Women have long worked as civilians, providing services to the military in the areas of health and medical assistance, administrative assistance, accounting, etc.

<sup>3</sup> With the exception of Venezuela, where 10 percent of all service members in the armed forces are women, these figures are typical for countries in the Andean region of Latin America (for additional information, see Escobar nd).

on Terror” in Iraq and Afghanistan (Sjoberg 2005). No doubt because of their gender, some of the most infamous images of sexual abuse to emerge from the Abu Ghraib detention center in Iraq were of female soldiers overseeing and engaging in the sexual humiliation and degradation of male prisoners.<sup>4</sup> According to surveys conducted with former combatants in Sierra Leone, between 20-25 percent of rapes and gang rapes were perpetrated by groups of combatants that included women (Cohen 2008). Women were also agents in the 1994 genocide in Rwanda, aiding in the deaths and sexual abuse of an unknown number of civilians (African Rights 1995).<sup>5</sup>

The recent work of Dara Kay Cohen has introduced a new explanation of why sexual violence occurs in some civil wars but not others and why some armed groups engage in this form of violence, but others do not (2010). Drawing on evidence from El Salvador, Timor-Leste and Sierra Leone, she argues that those groups that rely on abducted and forcibly recruited individuals to serve in their armies will lack internal cohesion. Internal cohesion, or the sense of closeness and trust amongst members is necessary to the effective fighting of any armed organization. These bonds are particularly difficult to form when individuals are kidnapped from their homes and forced to serve alongside relative strangers, with whom they have no former experience (such as that offered in basic training or military and police academies) or opportunities to build a relationship. She argues that rape and gang rape result from a process of combatant

---

<sup>4</sup> Mia Bloom has noted the facilitator role played by a local woman in Iraq to coordinate the sexual attacks of women. The raped (and dishonored) women are then persuaded to join insurgent forces as suicide bombers. In this way, the recruiters argue, their death will be meaningful and bring honor to their families (personal communication 2011).

<sup>5</sup> In 2001, the International Criminal Tribunal for Rwanda (ICTR) indicted the former Minister of Family and Women’s Development, Pauline Nyiramasuhuko, for genocide and crimes against humanity, including rape. This is the first time in international history that a woman has ever been charged with rape as a crime against humanity. The former Minister is accused of having encouraged and assisted the *interahamwe* militia to rape and murder civilians.

socialization, whereby newly “recruited” members consciously or subconsciously participate in such violence in order to signal to others that they are *real* members of the group and can be trusted. In situations of extreme coercion and violence, such as that felt by newly inducted members of an armed group who may be punished for defiant behavior, convincing your fellow soldiers that you are just like them, can mean the difference between life and death. As Cohen writes,

... it is not that individual combatants necessarily want to be more cohesive with the group that has just forcibly kidnapped him or her, but rather that exit from the group is often not a viable option. Conditional on being trapped in a group of hostile strangers, individuals may choose participation in costly group behavior over continued estrangement from his or her peers. The existence and maintenance of social cohesion is of great importance to the ability of combatant groups to survive as a group (to avoid desertion attempts or uprisings from below) and sexual violence is a powerful means of creating this cohesion.

(2010, 37-38)

There is some credibility to the author’s claims. As we will see in Chapters 4 and 7, in both Peru and El Salvador, the army was the most frequent perpetrator of sexual violence. Both institutions relied on forced conscription to fill its ranks. That said, it is not clear how the “combatant socialization theory” applies to forms of sexual violence other than rape and gang rape. As Chapter 3 illustrates, much of the literature has focused solely on incidents of rape and gang rape. However, rape and gang rape are not the only forms of sexual violence perpetrated during war; in fact, sometimes they are not even the most prevalent forms of sexual violence.

Lastly, some scholars have begun to examine the organization and ideological orientation and training of armed groups to understand why some perpetrate sexual violence while others do not (Hoover Green 2010). Some have argued that armed groups that seek to govern the populace will refrain from sexual violence in order to

maintain its image as a legitimate political authority (Wood 2006). It is not clear, however, why this same logic would not similarly prevent such armed groups from engaging in other illicit forms of violence, such as kidnapping for ransom or torture. Moreover, this argument cannot account for why state militaries, even under democratic leadership, often perpetrate sexual violence in war. Why would states not be similarly concerned with maintaining their political power and legitimacy to govern?

This dissertation contributes to this burgeoning literature by documenting the patterns of state repression during the civil wars in Peru and El Salvador and by explaining why sexual violence occurs where and when it does. Testing theories of strategic and opportunistic violence, I argue that sexual violence is often, although not always, a deliberate act of violence perpetrated to advance the political and military goals of the state. I argue against the conventional wisdom that sexual violence is simply the unfortunate, illicit behavior of a few soldiers acting in isolation and beyond the control of their superiors. I present a model of sexual violence in counterinsurgency wars, which argues that state armed forces will commit sexual violence at times and in locations where rebel activity presents a threat to state power *but* where the rebels have not yet reached dominance. In turn, the armed forces will refrain from such abuses in areas where the state retains control as well as in areas where there is a preponderance of rebel power such that the state cannot engage in counterinsurgency operations without risking a significant loss of life.

Counterinsurgency conflicts are distinct from conventional wars in that the state armed forces are faced with an armed opposition that operates in small groups that are often indistinguishable from the civilian population on which they rely for information,

supplies and other forms of support.<sup>6</sup> These small, armed bands are highly mobile and adaptive; as quickly as they move into a territory to stage an attack, they can also retreat. As a result, the skills and strategies that benefit state armies during conventional warfare, such as the ability to execute large-scale maneuvers, occupy and hold swathes of territory for extended periods of time or use massive firepower may be of limited utility or counterproductive to counterinsurgency missions. Instead, states often focus on population control and policing measures to identify, neutralize and/or eliminate members of the insurgency. It is during these kinds of operations – when states raid villages, conduct house-by-house searches to root out the rebels; when states detain entire subgroups of the population identified as sympathetic to or members of the opposition – that sexual violence may be wielded to advance the state’s military and political goals.

This dissertation provides a theory of sexual violence perpetrated by state militaries during counterinsurgency conflicts. In this way, it broadens our understanding of the causes of sexual violence beyond the few extreme cases of mass rape in ethnic wars that have oft been studied. The theory is likely generalizable to other counterinsurgency conflict situations, such as that in Iraq and Afghanistan where national and international armed forces are combating an irregular, insurgent organization. That said, I do not intend to provide a theory of all perpetrators of sexual violence in all types of conflict situations, as I do not believe that such a theory exists.

### **Case Selection and Justification**

The dissertation focuses on state-perpetrated violence. This focus should not be interpreted as an attempt to diminish or ignore the human rights violations perpetrated by

---

<sup>6</sup> While I focus here on the generalizable characteristics of insurgency and counterinsurgency, it is important to recognize that insurgent forces and the methods state use to defeat them vary historically and geographically.

non-state armed groups. Previous studies have shown that, while state and non-state armed groups vary in their commission of human rights violations, it is more often state armed forces who perpetrate sexual violence (Cohen 2010; Green 2006; Leiby 2009).<sup>7</sup> That said, state militaries' willingness to engage in wartime sexual violence has been highly uneven across conflict situations.<sup>8</sup> Despite this variation, the literature has focused almost exclusively on extreme cases of sexual violence in ethnic civil wars. By selecting on the dependent variable, these studies risk causal inferences that are biased or not generalizable (King, Keohane and Verba 1994; Geddes 2003).<sup>9</sup> Studying non-ethnic conflicts in a region of the world that is often ignored by the literature allows me to test the generalizability of findings to date and to broaden our understanding of the causes of sexual violence to a multitude of conflict settings.

The cases under investigation here were originally chosen to reflect attention to the variation in the frequency and patterns of sexual violence as well as the significantly different conflict settings in Peru and El Salvador.

---

<sup>7</sup> Dara Cohen finds that the state armed forces engaged in sexual violence in 86 percent of all civil wars between 1980 and 1999. Green (2006) similarly found that in 84 percent of collective rape episodes, government agents and armed groups were the perpetrator. In one third of these cases, the state armed forces were the *sole* perpetrator of sexual violence (Cohen 2010). In Latin America, the state more frequently perpetrated sexual violence. The state was implicated in crimes of sexual violence in *all* of the wars in the region. Two-thirds of the conflicts involved both state and non-state perpetrators of sexual violence; one-third involved *only* state perpetrators. Most notably, there was not a single conflict in which non-state armed groups alone engaged in sexual violence (Cohen 2010).

<sup>8</sup> In Latin America alone, there has been remarkable variation in the level of both state and non-state armed groups' use of sexual violence during war. The dictatorships of the late 1970's in Argentina, Uruguay and Chile reportedly resorted to sexual torture and rape during the detention and interrogation of suspected political opponents (Bunster-Burotto 1986). In the 1980's, it is estimated that the Guatemalan state raped thousands of Mayan women, often accused of subversive activities for no other reason than their residence in a rural community (REMHI 1999). In the 1990's Mexico countered a violent insurrection in its southernmost state with localized repression, but low levels of sexual violence. Finally, human rights organizations have reported that sexual violence is widely practiced by all sides of the ongoing armed conflict in Colombia.

<sup>9</sup> Some scholars have begun to examine in greater depth the variation in the prevalence of sexual violence across conflict situations, including those cases in which sexual violence is relatively low or absent (Wood 2006 and 2009).

	<b>Peru</b>	<b>El Salvador</b>
Level of State-Perpetrated Sexual Violence	Moderate-High	Low*
Conflict Type	(Counter) Terrorism war with some ethnic dimension	Classic Cold War era (counter) revolutionary war with no ethnic dimension
Regime Type	Electoral democracy	Military-dominated
International Constraints on State Behavior	Low	Moderate-High
Domestic Constraints on State Behavior	Low	Moderate-High

**Table 1.1 Case Selection**

The comparative analysis of the prevalence of wartime sexual violence in Peru and El Salvador was dropped from the current investigation due to an unanticipated research obstacle (discussed in further detail in Chapter 7 and Appendix F). Once the true frequency of sexual violence during the Salvadoran civil war can be confirmed, cross-national comparisons will be made drawing on the variation outlined in Table 1.1.

### **Data**

The data employed for the dissertation consist of both primary and secondary sources. I conducted 19 months of field research in Peru, El Salvador and the United States between August 2007 and November 2009. My research findings are based on the following sources:

- *Archived Human Rights Documents*. I read approximately 7,000 testimonial accounts of political violence collected by the Peruvian Truth and Reconciliation Commission and two Salvadoran non-governmental human rights organizations – Tutela Legal Arzobispado, (The Office of Legal Aid of the Archdiocese, herein reported as Tutela Legal) and Socorro Jurídico Cristiano (Christian Legal Aid, herein reported as SJC). These first-hand accounts are the basis of my dataset on



political and sexual violence during the Salvadoran and Peruvian civil wars. A complete description of each archive is available in Appendix A.

- *Local and International Media Reports.* Using the Foreign Broadcast Information Service (FBIS), which captures international as well as localized print and broadcast media, I created an events dataset on war-related activities in each country. These include, but are not limited to: troop movements, one-sided attacks or community invasions, battles, and mobilization or recruitment efforts by armed groups.
- *Census Records.* For each country, I collected all available data on measures of gender equality at the department level over time. All measures are recorded as comparative levels or rates between men and women and include, but are not limited to: infant mortality, life expectancy, literacy and school attendance, and economic activity.
- *Declassified Military Records and Journals.* I extensively read publications by military officers in academic and policy journals to understand the institutional histories, hierarchies, military culture and training procedures of the armed forces in Peru and El Salvador. I supplemented this information with declassified documents from the U.S. State Department, the CIA, the Department of Defense and local embassies, which are available from the National Security Archives in Washington, D.C. Documents on Peru come from the collection *Peru: Human Rights, Drugs and Democracy, 1980-2000*. Documents on El Salvador come from the collections *El Salvador: The Making of U.S. Policy, 1977-1984* and *El Salvador: War, Peace and Human Rights, 1980-1994*.

- *Interviews.* I conducted approximately 45 interviews with local scholars, members of the human rights and women's rights movements, and staff, volunteers and executive commissioners of the Peruvian Truth and Reconciliation Commission, Tutela Legal and SJC. The interviews were semi-structured and respondents' comments were recorded in a plain notebook. All interviews were conducted in Spanish and lasted an average of 90 minutes.
- *Secondary Sources.* I rely extensively on secondary materials to inform my analysis of the historical processes and dynamics of the conflict period, as well as my discussion of gender and race relations in each country.

### **Organization of the Dissertation**

Chapter 2 establishes the theoretical framework for the dissertation. It applies the current academic research on state repression to the study of wartime sexual violence. The chapter provides an overview of the dominant theoretical and methodological approaches to the study of state violence and their contributions and limitations. It presents a model of state-perpetrated sexual violence as an instrument of war in counterinsurgency conflicts and presents specific hypotheses to be tested.

Chapter 3 explores the methodological obstacles to research on wartime sexual violence and the extent to which they can be overcome with archival research. It discusses issues of concept formation, counting victims of human rights abuse and coding violations. It compares published figures from the truth commissions and other human rights institutions in Peru and El Salvador to the original testimonies of victims and witnesses and finds that (1) sexual violence is more prevalent in Peru than previously thought, (2) in both Peru and El Salvador, men are more often the targets of sexual

violence than previously thought, and (3) that wartime sexual violence is not limited to rape; sexual humiliation and sexual torture were common practices during both conflicts.

The remainder of the dissertation is organized geographically and thematically. Chapter 4 provides an in-depth historical analysis of the civil war in Peru. It describes the organization and operations of the principal armed opposition organization, the Shining Path. Foreshadowing a key finding in Chapter 6 that the frequency of sexual violence varies significantly across presidential administrations, the chapter examines the state's national security doctrine and changes in its counterinsurgency strategy over time. The evidence presented suggests that the state employed a broad conception of the opposition, putting members of the unarmed political opposition at significant risk for state repression, including sexual violence. This information is important to understanding why and against whom the state armed forces perpetrated sexual violence.

Chapter 5 examines the in-country variation in the timing and location of political and sexual violations in Peru. It tests the theory presented in Chapter 2 that wartime sexual violence is more likely at times and in locations where the armed opposition engages in frequent attacks against the state but is not yet in complete control. The results of a negative binomial regression model show a curvilinear relationship between national security threats and the prevalence of state-perpetrated sexual violence.

Further supporting the contention that wartime sexual violence in Peru was politically motivated, Chapter 6 provides additional descriptive and inferential statistics on the victims and perpetrators of state violence. I find that the profile of sexual violence victims is statistically different from that of other human rights violations. In Peru, victims of sexual violence are both male and female, tend to be more educated, are less

likely to be members of rural indigenous communities, and are *not* members of the population to whom soldiers had the most access. While there is no evidence that the military high command ordered its soldiers to commit sexual violence, that they were often present during the commission of such abuses indicates at a minimum their tacit approval of soldiers' actions. Similar to the patterns of perpetration of wartime sexual violence in El Salvador, sexual violence in Peru was most often perpetrated in rural communities, particularly in the area immediately surrounding a military installation and during the punishment and/or interrogation of political prisoners at state-run detention facilities.

Chapter 7 begins by discussing the contested frequency of sexual violence during the civil war in El Salvador. It then presents the patterns of sexual abuse with particular attention to the ways in which sexual violence differs from other forms of state repression. Sexual violence was targeted against women and men. Teachers and university students and members of human rights or workers rights advocacy groups were at particular risk for sexual violence. State security officials engaged in sexual violence during community raids *and* during the detention and/or interrogation of captured insurgents and other political prisoners.

Chapter 8 offers concluding remarks regarding the state's use of sexual violence during the civil wars in Peru and El Salvador. It reviews the evidence about the primary motivations for this form of violence in counterinsurgency wars. Finally, it outlines an agenda for additional research in this area and provides preliminary prescriptions to the policy community to confront and prevent sexual violence in ongoing and future conflicts.

## CHAPTER 2

### TOWARDS A THEORY OF WARTIME SEXUAL VIOLENCE IN COUNTERINSURGENCY WARS

Why do soldiers rape? Despite increased media scrutiny and research, the answer to this question continues to elude policymakers and scholars alike. As discussed in the previous chapter, the literature on wartime sexual violence offers a number of hypotheses on the causes of sexual violence but few rigorous comparative empirical analyses. In this chapter, I focus on one question: *whose* interests motivate rape and sexual abuse in times of war? I use the principal-agent relationship as an organizational frame to review the primary debate in the literature on state repression: opportunity versus strategy. The first camp sees sexual violence as a crime of opportunity, motivated from below by self-interested soldiers, while the second believes that sexual violence is orchestrated or motivated from above by the political and military leadership who view it as a strategic weapon of war. My contribution to this debate is to develop testable hypotheses at the sub-national level, and explore the contextual characteristics of the violations themselves and the objectives and dynamics of the conflict, a research design that will more accurately explain the motivating goals of wartime sexual violence.

The chapter is organized into four sections. I begin with a general description of the core characteristics of the principal-agent relationship and provide illustrative examples. I then explore in greater detail the argument that wartime sexual violence results when agents (soldiers) are able to pursue their private interests for violence outside the purview of their principals' (commanders') oversight and control. Next, I examine the multiplicity of instrumental functions that sexual violence may serve in

times of war, including ethnic cleansing, population control during counter-terrorism operations, and enforcement of gender norms of behavior. I outline the observable implications that can be derived from each competing argument, the cross-national and case-study evidence and empirical findings cited in the literature, as well as the hypotheses that will be tested at the sub-national level in Chapters 4, 6 and 7. I argue that there is no universal experience of wartime sexual violence, that even within the same conflict, such abuses will be perpetrated in different contexts and at different times for different reasons. Sensitivity to this variation, as opposed to strict adherence to parsimonious theories, is necessary for a comprehensive understanding of the causes of wartime sexual violence and effective policies to prevent future violence.

### **Whose Interests? Principals, Agents and Wartime Sexual Violence**

Principal-agent theory emerged from the rational choice literature on transaction costs (Coase 1937, Weingast 1984). The relationship between principals (leaders) and agents (subordinates) has since been used in analyses of social, economic and political phenomena for decades (Arrow 1985, Weber 1958). A principal-agent relationship exists anytime one person is entrusted to act in the interests of another. It is primarily characterized as an asymmetric relationship in which the principal bestows or authorizes an agent to carry out a task or duty on his behalf (either because he is unwilling or unable to do so himself). Owing to its rational-choice roots, principals and agents are assumed to be rational actors who make decisions to maximize their preferences. Both enter into the relationship because they profit from the exchange, the principal by getting something done he otherwise would not have, and the agent by receiving a benefit of some kind (money, social recognition, avoidance of punishment, etc.) for her efforts.

Principal-agent theory has been used to investigate the inner workings of firms and the relationships between contracting parties or employers and employees (Brehm and Gates 2000, Brudney 1985); political bureaucracies and international organizations (Hawkins et al. 2006, Weingast 1984); and democratic processes and the relationship between voters and elected representatives (Ferejohn 1999, Strøm 2000). A classic example from the economics literature is the relationship between the owners or stockholders and managers of a private firm. Stockholders have bestowed a trust in the managers of the corporation to protect their financial interests and earn them a profitable return on their investment. The basis of the principal-agent relationship is a contract, whether formal or informal, in which the agent agrees to pursue the principal's goals in exchange for some form of compensation.

In the following sections, I will use the principal-agent relationship as a lens through which to examine two scenarios in which state armed actors may perpetrate wartime sexual violence with frequency. In the context of armed conflict, the principals represent the political and military leadership of the state, while the agents are the individual soldiers and security officers who implement their war strategy. The first theoretical camp is referred to as the *opportunity model* and argues that agents, and **not** principals, have a private interest to engage in sexual abuse **and** principals are unable to effectively circumscribe the agents' self-gratifying, violent behavior.<sup>10</sup> Sexual violence arises because the chaotic circumstances of war provide so-motivated agents the

---

<sup>10</sup> There are a number of reasons why principals would not want their agents to engage in sexual violence during war. Soldiers who engage in sexual violence may contract a sexually transmitted infection, which may cause physical impairments or side effects that undermine the readiness and efficacy of troops. Perpetrating sexual violence also could threaten, undermine or distract away from the operational mission of deployed soldiers. In particular, it could limit the unit's ability to win the "hearts and minds" of the civilian population – a strategic imperative to counterinsurgency or counterterrorism efforts.

opportunity to commit abuses without the knowledge or consent of their superiors. The second theoretical camp is referred to as the *state strategy model* and argues that **both** agents and principals have a preference, albeit for different reasons, for agents to commit sexual abuse. From the principal's perspective, sexual violence is a desired and strategic tool to be wielded in times of war pursuant to their overall military and political objectives. Each argument is considered in greater detail below.

### **Opportunity Model**

The principal-agent relationship is mutually beneficial. However, when there exists *goal variance* and *information asymmetry* between principals and agents, the exchange may actually become suboptimal for principals. Goal variance refers to any situation where principals and agents are motivated by different interests. Information asymmetry describes the condition of all relationships based on delegation in which the principal has imperfect information on the decisions and actions of his agents, such that he cannot know with certainty if his agents are doing their best to carry out the jobs for which they have been contracted. Below, I will first illustrate these dynamics and then demonstrate how the same principles can be applied to military leaders and their soldiers to explain why the latter engage in sexual violence during war.

Corporate management can often run astray from the interests of its shareholders, resulting in outcomes that may be disastrously suboptimal.<sup>11</sup> In return for their initial investment, stockholders expect the value of their shares to increase over time. They expect the firm to be run in a way that will produce long-term growth in earnings and/or dividends, depending on the type of company. Corporate managers, on the other hand,

---

<sup>11</sup> This is illustrated by the recent scandals involving the Ponzi scheme run by the Bernard L. Madoff Investment Securities firm and the epic mismanagement and fraud perpetrated by the Enron Corporation.



have incentives to pursue their own preferences for large bonuses, which can lead to choices or policies that undermine the firm's long-term prospects but produce the possibility of large, short-term windfalls. In other words, shareholders and corporate managers do not have the same goals. Additionally, investors are far removed from the day-to-day operations of the firm and have limited information on the actions and decisions of the managers. As a result, investors have little control over the firm's management and are in a poor position to ensure that their agents protect their financial interests.

Wartime sexual violence is perhaps a perfect illustration of the principal-agent dilemma. In times of war, the normal social and institutional mechanisms that regulate behavior are loosened or destroyed. There exists a general environment of anonymity and permissiveness that allows individual agents (in this case, soldiers) to pursue their private interest for violence without fear of detection or retribution from commanding officers (principal). Wartime sexual violence arises when leaders are unable to monitor and control the behavior of agents under their command (Butler et al. 2007). Simply, war increases the *opportunity* for those who are so inclined to commit sexual violence.

More specifically, in times of war state authorities must delegate security tasks to agents, namely soldiers, officers and other members of state security institutions. These individual agents are motivated by multiple and often unobservable interests or goals (Hoover 2006). Agents are generally assumed to be selfish. When conditions permit, soldiers will forsake the goals of their commanders and pursue their own private goals and desires (Butler et al. 2007, Mitchell 2002). Because of the nature of their work, security agencies may attract individuals who are predisposed or have a predilection for

violence. This is referred to as *adverse selection*, and is particularly problematic in times of low recruitment and high demand on the agencies' services.<sup>12</sup> Soldiers may be motivated by revenge, sexual or other forms of gratification, power, group acceptance and peer esteem or conversely, the avoidance of their ridicule or abuse.<sup>13</sup>

In times of war, both conditions of the principal-agent dilemma can be met: (1) there exists a gulf between the private interests of rank-and-file soldiers and the strategic goals of commanders in the defense department or central government, and (2) there is weak surveillance of the actions and behavior of soldiers by the leadership. As Landman and Godhes write:

Principals tend to have long-term goals and a broader picture of the conflict in indentifying key aims and objectives that they wish to achieve, while agents have shorter-term goals and more localized understanding of the conflict that can clash with the aims and objectives of the principal...and they may well misrepresent events from the field of conflict for reasons to further their own goals, whether those are motivated by self-interested greed or sadism.

(2009, 6)

Because state militaries are made up of smaller units, whose members' loyalties may conflict with the norms and purposes of the institution and its mission, the success of

---

<sup>12</sup> Since the onset of the concurrent wars in Afghanistan in 2002 and Iraq in 2003, the U.S. Armed Forces have struggled to recruit and retain soldiers and marines. To increase the number of new recruits, the military has issued "Moral Waivers" to allow the entrance of those with criminal records, a factor that previously disqualified an individual from military service. According to a 2008 article in *Army Times*, one of out every eight Army recruits requires such a waiver, a rate more than double of that in 2004 (Michaels 2008). While the Armed Forces assert that most waivers are granted for misdemeanor convictions, others were given to violent felons, including those convicted of making terrorist threats, sexual assault, child abuse, and maiming (Schor 2008). Lilly (2007) has studied wartime rape perpetrated by the U.S. military since World War II and found it to be associated with poor recruitment and pre-screening of recruits. Specific hypotheses regarding the recruitment strategies of armed groups will not be tested here because I do not have access to individual-level data on soldiers' behavior and careers.

<sup>13</sup> On this latter motive, some scholars have begun to examine the group dynamics and norms of small armed units (Wood, 2009). Soldiers, acting as members of small groups, may commit acts of sexual violence that they would not commit as individuals operating alone, perhaps because they want to gain the esteem of their comrades or because their feelings of individual culpability is diminished when acting as a member of a collectivity.

military operations requires effective command and control to ensure unit discipline and adherence to the institutional mandate (Valenius 2004).

### **Evidence Regarding Opportunity Model of Wartime Sexual Violence**

The opportunity model produces several testable hypotheses regarding the prevalence of sexual violence, the identity of the perpetrators and victims, the type of sexual violence, and the location and context in which they are perpetrated (summarized in Table 2.1). The following section summarizes the specific hypotheses that have been tested by previous research and the results of these tests. Given the small number of studies (four to date), additional research, particularly case study and sub-national research, is necessary to rigorously examine the observable implications of the opportunity model of wartime sexual violence.

First, the opportunity model implies that sexual violence will be more prevalent in situations of chaos or upheaval, where mal-intentioned individuals can exploit for their own benefit the inability of government or social institutions to monitor their behavior and enforce the norms or laws regarding the use of violence. At the cross-national level this means that the level of sexual violence should increase in times of war, state failure or government collapse, or periods of great economic, political or social instability. This hypothesis is supported by Butler et al. (2007) and Green (2006), who find evidence that armed conflict increases the prevalence of sexual violence, as does the intensity of the conflict.<sup>14</sup> Applying the same logic to the sub-national level, I hypothesize that sexual

---

<sup>14</sup> Green includes measures of civil conflict, internationalized civil conflict, inter-state conflict (at no fatalities, 1-25 fatalities, 26-999 fatalities, and 1,000+ fatalities from the Uppsala PRIO Armed Conflict Database) and ethnic war, genocide, and revolutionary war (at no fatalities, less than 100 fatalities, 100-1,000 fatalities, 1,000-5,000 fatalities, 5,000-10,000 fatalities and 10,000+ fatalities from the State Failure Project). She finds that all, except for the presence of inter-state conflict, increase the probability that a country experiences a collective rape episode. The absence of a significant relationship between interstate war and collective rape, she argues, is likely due to the relatively small number of international wars

violence will be more prevalent during or immediately following battles or violent attacks rather than during occupations.

Second, the opportunity model indicates that levels of wartime sexual violence will be higher when commanders have less information on the behavior of their soldiers. Commanders' information disadvantage is likely to be greatest when they must delegate responsibility and authority to their subordinates *and* when soldiers are geographically separated and distant from the watchful eye of superior officers. Therefore, sexual violence will be more likely to occur when soldiers are deployed to the "field" – to battlefields or combat zones that are far from command centers. Butler et al. found preliminary evidence to support the proposition that sexual violence is more likely to occur in situations, regardless of armed conflict, where agents are given greater discretionary powers, where monitoring of and accountability for behavior is low (2007).

The unit of analysis in the Butler et al. study is the country-year, which requires the use of aggregate data that only indirectly measure the independent variables specified in the opportunity model. Democracy (as measured by the Polity IV index) is used to capture the availability of information to leaders on their subordinates' behavior. Gross national income (GNI) is said to proxy public sector wages (such as those of police officers or government officials), and levels of financial corruption (as measured by the World Bank's Control of Corruption index, itself based on the perceptions of business executives and country experts) are used to indicate the willingness of public servants to

---

between 1980 and 2003 as well as the evolution of combat in such conflicts that dramatically reduces the interactions between militaries and civilian populations, as compared to civil wars (2006, 140-142). However, combat operations in international counterinsurgency wars, such as those in Iraq and Afghanistan, require almost constant interactions and sometimes cohabitation between soldiers and civilians. Additional research on the prevalence of sexual violence during such conflicts is necessary. Butler, et al. includes measures of civil conflict and civil war (at 25-999 fatalities and 999+ fatalities, respectively, from the Uppsala PRIO Armed Conflict Database).

exploit their positions for their own benefit or financial gain. Financial corruption, the authors argue, “deals with the financial rewards that public officials extract from performing or not performing their duties. High levels of financial corruption reflect a general absence of monitoring, accountability, and control in a political system and a high degree of agent discretion to pursue hidden actions” (Butler et al. 2007, 674). The authors contend that the same dynamic is applicable to the state armed forces.

There is also some case study evidence to support the opportunity model of violence. Although not specific to sexual abuse, Siver’s study (2009) of violence against civilians during American operations in the Korean War (1950-1953), British occupation during the Malayan emergency (1948-1953), and the Canadian peacekeeping mission in Somalia (1993) underscores the importance of command control to prevent agents’ opportunistic violence. She finds that the military units that were not effectively led and constrained by junior officers were more likely to commit war crimes. The ability of leaders to control their subordinates’ behavior was a more powerful predictor of violence against civilians than the training received by soldiers on the laws of war and human rights norms and the ideological framing of the war effort by civilian political leaders.

The actions of the 2 Commando of the Canadian Airborne Regiment in Somalia clearly illustrates the dangerous potential for violence when principals are unable to regulate agents’ compliance with their norms of behavior. On March 16, 1993, members of the 2 Commando tortured and beat to death sixteen-year-old Shidane Arone, a civilian. The unit was known as the “roughest” and “toughest” of the Canadian Airborne Regiment and proudly flaunted its insubordinate, anti-authority subculture, adopting the Confederate flag as a symbol of their rebellion against the military leadership. The 2

Commando had widespread disciplinary problems, including burning a junior officer's car, and frequently erected a wall of silence to thwart investigations of the unit's behavior. Siver notes that the 3 Commando received similar training regarding the laws of war, had the same mission, faced similar challenges and dangers while deployed, and yet refrained from the kinds of "excesses" committed by the 2 Commando (2009). She attributes this to the ineffective leadership of the 2 Commando:

The dysfunctional junior officer assignment system in 2 Commando meant that junior officers could not effectively discipline the unit or enforce organizational norms. Weak junior leaders could not penetrate the subculture; leaders who attempted to do so strengthened the anti-authoritarian beliefs within the unit. 2 Commando lacked strong discipline and resisted all efforts to restrain their aggressive behavior, which eventually escalated to the killing of Shidane Arone. (2009, 34)

Lee (2005) similarly tests the applicability of the opportunity model to the use of force by the Thai and Indonesian militaries against civilian protestors in 1973 and 1998, respectively. In response to political protests in Bangkok, civilian authorities (as principals) in Thailand ordered the military to use violence to disperse the demonstrators. At first, the military (as agent) was compliant with the authorities' demands, but then refused to shoot. After three months of demonstrations, the government in Indonesia also ordered the military to use violence against student protestors. One of the deployed units complied with the government's orders, opening fire to disband the students, while the rest refused to do so. In deciding their course of actions, the opportunity model predicts that agents will carry out orders when leaders are able to effectively monitor and sanction their behavior. Agents ask themselves "will I be caught if I do not comply with orders?" *and* "will I be punished – fired, have my promotion withheld, or reassigned?" (Lee 2005:5).

Lee finds, however, that the opportunity model cannot adequately account for the varied compliance of the Indonesian and Thai militaries to the government's orders. He argues that government officials did not have sufficient institutional controls to monitor behavior within the Thai armed forces; nor did they have the capacity to effect personnel changes within the military during the period leading up to the October 1973 protests. In Indonesia, however, President Suharto did have monitoring capabilities and was able to keep tabs on the activities of the officer corps of the armed forces. The President also effectively exercised his power to make personnel changes within the armed forces in the years prior to the 1998 political demonstrations. The ability of civilian leaders to monitor and sanction errant behavior, while low in Thailand and high in Indonesia, was relatively uniform across military units and over time and thus cannot account for the change in the Thai armed forces' use of violence *or* the varied willingness of different units within the Indonesian military to fire on crowds of protestors (Lee 2005).

To summarize, there has been some evidence at the cross-national and case study level to support the opportunity model of wartime sexual violence. Both Green (2006) and Butler et al. (2007) found that sexual violence increases in times of war, periods of violent upheaval in which it is expected that individuals are more able to pursue their private interests to engage in sexual abuse. Butler et al. (2007) and Lee (2005) found conflicting evidence for the purported causal mechanism that violence is more common in situations where leaders are ill informed and unable to regulate their agents' proclivity towards personal, reward-seeking behavior. Likewise, the case studies from Lee (2005) and Siver (2009) studies present inconsistent evidence regarding the importance of principals' control over their agents' behavior to prevent violence against civilians during

civil and international conflicts. Because the empirical research on the opportunity model of violence is limited to three studies with mixed results, additional testing of the theory's core propositions is required.

I argue that a more rigorous test of the theory's assumptions and hypotheses requires in-depth, sub-national analysis, using fine-grained data on individual abuses. By examining the specific location where sexual crimes are committed, by whom and against whom they are perpetrated, as well as the details of the context in which they occur, we can more carefully and directly test the theoretical propositions of this model and better understand the causes of sexual violence in times of war. These hypotheses and how they will be tested at the sub-national level in Peru and El Salvador are outlined below.

Wartime sexual violence occurs in a variety of locations and contexts – in homes, fields, state-run detention facilities, rebel camps, and in refugee or internally displaced persons camps. However, if sexual violence is the result of opportunistic agents fulfilling their own desires for violence rather than the state's strategic interests, it should be more prevalent in the field where direct supervision over individuals' behavior is limited. Sexual violence should be minimal in situations where there is a higher degree of control and order, as in prisons, military bases or other institutional establishments. In these state-run facilities it is reasonable to presume that widespread human rights violations cannot occur without the knowledge of commanding officers. Instead, we should see a preponderance of cases in low visibility, private or secluded locations, such as abandoned buildings or remote rural areas, such as mountains or woods.

Additionally, where access, and thus opportunity, is constant, there should be no observable patterns of targeting individuals for sexual violence according to their social,



political or ethnic identities.<sup>15</sup> To the extent that particular subgroups live in geographically contested zones, they may be at greater risk for sexual violence. This may be the case for some ethnic groups that, because of cultural and economic ties to the land, are concentrated in geographically specific locations. However, it is less clear that the same could be said for members of opposition political parties, unions, university students or social activists. Therefore, I argue that opportunistic sexual violence will appear to be random with respect to the victim's identity.

Similar criteria were used by the International Criminal Tribunal for the Former Yugoslavia to determine the level of responsibility and participation of the central government in the commission of mass sexual violence. That sexual violence manifested itself in similar ways in geographically distant regions of the country, that victims appeared to be targeted, and that many offenses were perpetrated in official detention centers indicated that the state's use of sexual violence during the war in Bosnia-Herzegovina was planned and purposeful.

Lastly, this theory presumes that, given the same opportunities and assuming the same penchant for self-promotion, all armed groups within a given society will equally participate in sexual violence. This hypothesis is not explicitly tested in Butler et al. (2007). However, Cohen (2010) finds that wartime sexual violence is often asymmetrical – that is it is often perpetrated by one side of the conflict (the state armed forces *or* non-state rebel groups), but is not reciprocated by the other (108).<sup>16</sup> This would seem to imply that the different organizational structures of state and non-state armed groups

---

<sup>15</sup> Arguably patterns of perpetration may appear if individual agents are more inclined to target particular individuals for violence because of previously held biases.

<sup>16</sup> One outlier to this trend is the ongoing conflict in the Democratic Republic of Congo, where journalists and human rights activists have noted with horror the extent to which almost all of the armed groups in the country have engaged in sexual abuses (Hochschild 2009, McCrummen 2009).

result in disparate levels of control over their members’ behavior. However, to date, there has been no systematic analysis of this variation or if or how it can account for the different propensities of these groups to engage in sexual violence. The same can be said for the observed variance in the perpetration of sexual violence by different branches of the state security forces, such as the regular army, marines, navy, police and special operations forces. Moreover, this theory cannot explain why many, if not most, members of an armed group do not perpetrate sexual violence despite their peers’ willingness to do so. Chapters 5 and 6 explore how opportunity *alone* cannot account for all the observed variation in the perpetrators, victims and types of sexual violence in the Salvadoran and Peruvian civil wars.

<b>Summary of Opportunity Model of Wartime Sexual Violence</b>			
<b>Theoretical Hypothesis</b>	Sexual violence (and other forms of political violence) is carried out for private (not group) reasons when individuals have the opportunity to do so		
<b>Testable Hypothesis</b>		<b>Literature</b>	<b>Tested Here</b>
	Given the same opportunity, all members of an armed group (or all men) will commit sexual violence	Butler et al. 2007 Mitchell 2004 Brownmiller 1975	N
	Given the same opportunity, all armed groups will participate in sexual violence	Cohen 2010	Y
	Sexual violence will increase in times of war	Butler et al. 2007 Green 2006	N
	Sexual violence will correlate over time and across space with looting, pillaging and extortion	Leiby 2009a Wood 2006	N <sup>17</sup>
	Sexual violence will be absent or limited in state-run detention facilities	Leiby 2009a	Y
	Sexual violence will not be perpetrated by, in the presence of, or with the knowledge of commanding officers	Leiby 2009a	Y
	Sexual violence will not be targeted against “opponents of the state;” it will appear random in regard to victim profile	Leiby 2009a Wood 2006	Y
	Leaders will properly investigate cases of sexual violence		N

<sup>17</sup> This hypothesis is not tested because I do not have systematic data on state militaries’ participation in cattle rustling and pillaging. However, some scholars have found a correlation between wartime sexual violence and these opportunistic crimes. In the Democratic Republic of Congo, for example, researchers have noted that “many cases of sexual violence take place in the context of riots and pillage; these rapes are often connected to demands for survivors to surrender goods or to pay taxes to the armed group” (Eriksson Baaz and Stern 2010, 15).

**Table 2.1 Model of Wartime Sexual Violence as Opportunistic Violence: Observable Implications and Literature**

### **State Strategy Model**

What if agents are, in fact, good stewards of their principal's interests? It is not necessarily the case, as the opportunity model presumes, that the state government and military leadership do not want sexual violence to occur. The state strategy model, described below, assumes that soldiers are simply carrying out the orders of their superiors and explores the various reasons that the state may seek to encourage, condone or directly order the use of sexual violence during times of war. According to this view, sexual violence is a part or method of war, rather than a mere incidental consequence of it.

A weapon of war is “any instrument or device for use in attack or defense in combat, fighting or war.” To be considered a weapon of war, it must be “used as part of a systematic political campaign which has strategic military purposes” (Skjelsbaek 2001, 213). Demonstrating that sexual violence was strategically employed to further the state's war objectives is not easy. Without interviewing the perpetrators of sexual violence or discovering evidence of a policy of rape, it is difficult to prove that leaders of the highest echelons of the military or central government ordered or even encouraged soldiers to rape.<sup>18</sup> However, I disagree with other scholars (Cohen 2010, Eriksson Baaz and Stern 2010) who suggest that the absence of such evidence is sufficient grounds to

---

<sup>18</sup> This research strategy has been employed by Martha Huggins (2002) and Inger Skjelsbæk (2011) to interview suspected and known “violence workers” from Brazil and perpetrators of sexual violence in the former Yugoslavia, respectively. By necessity, both studies are limited in scope. Huggins focused on persons who were incarcerated for other, unrelated, criminal offenses, perhaps making them more willing to participate in the study. Skjelsbæk's study is based on a small, non-random sample of perpetrators who testified before the International Criminal Tribunal for Yugoslavia. It is not clear how transportable this research strategy is to other post-conflict settings or what it could tell us about the motives behind military and government leaders' decisions, as individual perpetrators of violence may not have access to this information.

disprove the existence of central government planning and strategy. Requiring definitive proof of this kind sets an unachievable standard and unnecessarily privileges state impunity.<sup>19</sup> Obviously, state leaders have strong incentives to maintain secrecy around such criminal behavior. There are other observable implications, however, that allow us to judge whether the existence of a deliberate state strategy of wartime sexual violence is more or less likely.

In the following section, I review the literature that theorizes wartime sexual violence as an explicit state warfare strategy. I then discuss the observable implications of the model and outline the sub-national hypotheses that will be tested in Chapters 4, 6 and 7 (see Table 2.2 below). Again, I argue that focusing on the sub-national level is a more fruitful and accurate method of empirical inquiry of the causes of wartime sexual violence. By examining the patterns of perpetration of sexual and other human rights abuses, scholars can evaluate the plausibility of leaders' claims that they had no knowledge of, did not encourage, and strictly prohibited illegal acts of violence by their militaries.

---

<sup>19</sup> On this point, the prosecution of former Peruvian President Alberto Ken'ya Fujimori Fujimori for the kidnappings of Samuel Dyer and Gustavo Gorriti and the extrajudicial executions of twenty-five persons at the tenement house in Barrios Altos and at la Universidad Nacional de Educación Enrique Guzmán y Valle (also known as La Cantuta University), is instructive. The Special Criminal Chamber of the Supreme Court convicted Fujimori as the *autor mediato*, or indirect perpetrator of these crimes, and argued that such a finding did not require them to establish that he had formally or in writing ordered the Colina group to kidnap or kill the victims. The Chamber argued that such orders "may be written, verbal, express, or implied" (Sala Penal Especial de la Corte Suprema 2009, 743). The Chamber elaborates "[t]he existence of [a] "policy" can be proven based on the finding of legal provisions, administrative decisions or official directives, but they are not a necessary requirement. Thus, for example, the European Court of Human Rights allows for such a practice or policy to be identified through (i) an accumulation of identical or analogous violations, sufficiently numerous and interconnected so as to be not mere isolated incidents or exceptions, but rather a pattern or system; and (ii) the official tolerance of State authorities...[which] is understood as the fact that the superiors, in spite of having knowledge of the violations, refuse to take measures to punish those responsible or to prevent the repetition of the violations, or they express their indifference by refusing to conduct an adequate investigation into the truth or falsehood of the alleged abuses" (Sala Penal Especial de la Corte Suprema 2009, 685-686).

Studies examining the use of sexual violence as a weapon of war emerged in large part in response to the atrocities committed in Bosnia-Herzegovina and Rwanda in the early 1990s. The severity of these cases, while unfortunately not unique, makes them significant to studies of the determinants of sexual violence. However, much of this research has resulted in mono-causal theories that focus narrowly on the ethnic identity of the victims, conceptualizing sexual violence as ethnic violence perpetrated during campaigns of ethnic cleansing or genocide (Allen 1996, Bloom n.d., Mullins 2009, Sharlach 2000). This literature overlooks the fact that conflict settings differ in ways meaningful to our understanding of wartime sexual violence. Broadening the study of wartime sexual violence to conflicts in Latin America, which were not fought solely along ethnic lines, allows for analysis of the *multiple* strategic functions of sexual violence.

Beginning from the basic theoretical proposition that armed actors employ sexual violence strategically, the following sections explore its instrumentality during military operations. Two explicit functions are explored: (1) sexual violence as a method of undercutting popular support for opposition organizations and controlling the population, and (2) sexual violence as a method of torture used to acquire “actionable intelligence” on opposition organizations. As a weapon of war, sexual violence has a number of perverse benefits. It is relatively cheap and easy to use. It can boost the morale and unity of armed groups and can supplement the incomes of combatants. Perhaps most importantly, in societies with deeply held social mores about women’s honor and purity, sexual violence may be a particularly “effective” repressive and demoralizing weapon

(Allen 1996, Bastick et al. 2007, Bloom n.d., Mitchell 2004).<sup>20</sup> Because of the intimate nature of the attack on a person's understanding of self, sexual violence can be a particularly effective method of neutralizing political opponents without killing them. As one scholar describes:

[w]ith the help of different torture methods, the authorities seek to remove any human, reliable, or mutual relationship and thereby bring the prisoner into a state of extreme physical and psychological regression, where it is no longer possible to relate to the body, to the world outside or to other people.

(Agger 1986, 307).

How does a state employ sexual violence to neutralize support for the armed opposition? One possibility is the use of sexual violence as a form of state terrorism, to induce fear widely throughout the civilian population. As the state increases its repressive campaign against civilians, the fear of being targeted will dissuade a potential recruit from joining the ranks or providing aid to the armed opposition (Valentino 2004). Similarly, the state may use sexual violence against suspected "enemies of the state" to punish them for their opposition activities. Potential targets would include members of armed rebel groups, opposition political parties, or "subversive" community organizations, as well as those who support them. By targeting individuals for their participation in dissident organizations, states effectively signal to potential recruits their fate if they behave similarly and may induce some subversives either to abandon or betray the opposition (Kalyvas 2006). Whether targeted or indiscriminate in scope, the

---

<sup>20</sup> Despite the potential tactical and strategic benefits to armed groups, there are reasons why military leaders would discourage the use of sexual violence by their troops. The primary objective for any military commander is to impose order and discipline over his members in order that the military initiative can be achieved. Any activities, such as consensual sex, rape, consumption of drugs or alcohol, that undermine unit readiness and cohesion could threaten the capacity and effectiveness of the group. Additionally, engaging in illicit and criminal activity, especially that which is seen as so illegitimate so as to never be appropriate, undercuts civilian support for military missions, a crucial factor for success during irregular, counterinsurgency wars.

effect of the violence is the same; it undermines the ability of armed opposition groups to recruit and retain members or supporters.

In addition to undercutting the source of strength of the rebels, the state may also use sexual violence to collect intelligence on the opposition movement. The state may employ sexualized torture techniques during the interrogation of a suspected guerrilla to gather information about the identity of rebels, location of their camps or their military strategies, as was recently reported at the U.S. detention facilities at Guantanamo Bay in Cuba, Bagram airbase in Afghanistan, and Abu Ghraib in Iraq. Accounts suggest that detainees were subjected to a multitude of sexual abuses during interrogation and detention, ranging from sexual humiliation, forced masturbation, being stripped and photographed nude, rape, sodomy, and simulations of electric shock torture (HRW 2004b, c; Leonnig and Priest 2005).

How do we know when the state is employing sexual violence as a strategic weapon of war? Below, I outline the key theoretical hypotheses to be tested regarding the prevalence and patterns of sexual violence both *within* and *across* states in conflict.

There is a significant body of literature in comparative politics and international relations on the preconditions of state violence during war (Davenport 2006, Gartner and Regan 1996, Regan and Henderson 2002, Stanley 1996). From this perspective, sexual violence is conceptualized as one of the many forms of violence utilized by the state in times of war. The determinants of sexual violence, therefore, are inextricably linked to the war itself – in the absence of war, sexual violence would be infrequent – a finding confirmed by the literature (Butler et al. 2007, Green 2006).

In his review of academic research on state repression, Christian Davenport describes the “law of coercive responsiveness” as one of the most consistent findings in the literature. He states,

[b]y far the most long-standing and stable influence on state repression concerns political conflict. Dating back to, at least, Kautilya in India during the fourth century...or...Niccolo Machiavelli in Italy during the late 1400s and early 1500s or Thomas Hobbes in England during the late 1500s and early 1600s, it has been commonly thought that governing authorities should respond with repression to behavior that threatens the political system, government personnel, the economy, or the lives, beliefs and livelihoods of those within their territorial jurisdiction.

(2006, 7)

Faced with a challenge to its authority, to the status quo, to its national security, the state will respond with violence repression. From a rationalist perspective, violent repression is seen as an instrumental policy used to achieve the objectives and goals of the state (Azam and Hoeffler, 2002; Davenport, 1995 and 2000; Harff, 2003; Valentino, 2004).

As the perceived threat to the state increases so does the likelihood that authorities will respond with violence in order to eliminate the opposition and restore internal security and stability (Gartner and Regan 1996, Mason and Krane 1989, Moore 2000). While this finding has withstood empirical and methodological scrutiny through multiple replication analyses, there remain questions about exactly what the state perceives as a threat. “What do authorities perceive? What precisely do they respond to – death, property damage, wildly unorthodox behavior, or the magnitude, frequency, and location of challenging activity?” (Davenport 2006, 8).

The state’s threat perception is situational, multi-dimensional and spans the entire spectrum of contentious politics, from protests, riots and labor strikes to large-scale violence and civil war (Davenport 1995, Moore 2000). Opposition activities that make a



larger demand on the state and present a greater challenge to the status quo are more likely to evoke non-conciliatory and repressive responses from the state (Regan and Henderson 2002). The strength and organization of the opposition, its tactics and objectives imply different levels of threat for the state and thus different probabilities of the use of force. In general, large cohesive organizations are more dangerous than those that are poorly structured or lack a clear leadership or sufficient support base. Regardless of size, armed opposition groups pose a greater risk than opposition political parties or non-violent social movements. Groups whose primary goal is to overthrow the government or secede from the state threaten the very existence and organization of the state, and thus are more likely to be met with violence (Enloe, 2000; Mitchell, 2004).

These characteristics – the methods and objectives of the opposition groups – may help explain why sexual violence is more prevalent in some countries than in others. To date, this hypothesis has not been tested due to the lack of systematic and reliable cross-national data on the type, organization and strength of armed groups.<sup>21</sup> However, the same causal mechanism – that state sexual violence is relative to opposition threat – can be analyzed at the sub-national level.

The spatial variance in the state's use of sexual violence should be related to the presence and size or strength of the rebel armed forces. If wielded in response to national security threats as a weapon of irregular warfare, sexual violence should be limited to those departments/provinces where such a threat exists.<sup>22</sup>

---

<sup>21</sup> The closest to such an analysis is Cohen (2010), in which she tests hypotheses regarding the type of conflict (ethnic vs. non-ethnic), demands of the insurgents (secessionist claims vs. non-secessionist claims) and the recruitment strategy of the insurgents (forced vs. primarily voluntary). She finds that ethnic, genocidal and secessionist wars are no more likely to have high levels of sexual violence than other types of conflict where ethnic identity is not a cleavage of contention (Cohen 2010, 120).

<sup>22</sup> The level of threat posed to the state by the rebels is not uniform throughout the country or over time. The establishment of rebel bases in a vital commercial district such as San Isidro in Lima, Peru would yield

At times and in locations where the state is dominant (i.e. where the rebel organizations are not present or are present but at a low number and engage in infrequent assaults or military operations), there will be low levels of sexual violence because the state does not need to run counterinsurgency operations.<sup>23</sup> Studies have consistently found that armed actors, whether state or non-state actors, do not commit widespread violence in areas under their *own* control (Hultman 2006, Humphreys and Weinstein 2006, Ron 2003). If sexual violence is a weapon of war employed to weaken the opposition, it should be virtually absent in areas where the state maintains a clear monopoly of force.

At times and in locations where the rebel organizations are established and have engaged in subversive activities of sufficient frequency and/or intensity so as to gain the attention of the state and cause physical and economic damage, *but* where their military capacity does not match that of the state armed forces, the state will respond proactively with repression to prevent the rebels from recruiting more members and gaining enough strength to be a significant threat to the existence of the state. During this period of counterinsurgency warfare, the state will use high levels of sexual violence, torture, arbitrary detention and interrogation to (1) gain information on the identity of members of rebel groups, the location of their bases and weapons caches, etc., and (2) punish and terrorize members of rebel organizations and/or potential recruits to neutralize them.

---

a significantly different response from state authorities than such activity in Caballococha, located in the sparsely populated Amazon regions in Loreto. Similarly, the establishment of a rebel base at a time when the overall threat to the state is low will be of less consequence than when an additional base is established at a time of national security crisis. In this regard, controlling for the location of rebel bases and military operations (their distance from the capital and other economically and politically salient centers throughout the country) as well as the aggregate threat level over time will be important.

<sup>23</sup> If there is a high level of sexual violence, content analysis of the cases should reveal that they were of a purely opportunistic nature, that is, they were motivated by the private interests of individual soldiers and were not incorporated into the overall strategic agenda of the state armed forces.

At times and in locations where the strength of the rebel organization is on par with that of the state, there will be high levels of contestation and frequent battles between the two sides, but the state will refrain from sexual abuse. While the risk of state failure is high, the resources available to the armed forces are limited, thus requiring the military to focus its efforts on direct combat operations and forsake counterinsurgency and population control measures.

In her 2010 study, Dara Cohen finds that the most lethal conflicts also tend to have the highest levels of sexual violence (120). However, this finding is based on data aggregated at the conflict/country level. It is entirely plausible that these different forms of violence, while frequent during a particular conflict, occur at different times, in different areas, in different contexts and for very different reasons. If my theory of sexual violence as a weapon of counterinsurgency warfare is correct, the state will not engage in such abuses while in combat.

At times and in locations where the rebel organization is dominant (i.e. where the state is either not present or only minimally present), the state will not engage in high levels of sexual violence. Other scholars, such as Reed Wood, have argued that as rebel presence continues to grow, such that they control swathes of territory, they will be able to protect the civilian population from state violence, thus the observed level of state sexual violence and other human rights violations will decrease (2010). This assumes that the rebels are interested in protecting the civilian population from such abuse. While such an assumption is reasonable of the FMLN in El Salvador, which relied heavily on tactical support from the civilian population, this is not a tenable assumption of the Shining Path in Peru. Instead, I argue that the observation of state-perpetrated sexual

violence is minimal in areas and times of rebel control simply because the armed forces do not have the capacity to engage in unilateral counterinsurgency operations in these areas without risking the lives of its own members. The state will only rarely venture into rebel strongholds, and when it does, will only do so with a sizable contingent of soldiers capable of confronting the rebels.

Accordingly, the expected relationship between the prevalence of state-perpetrated sexual violence and the strength of the armed opposition will reflect an upside down U curve, as seen in Figure 2.1 below.

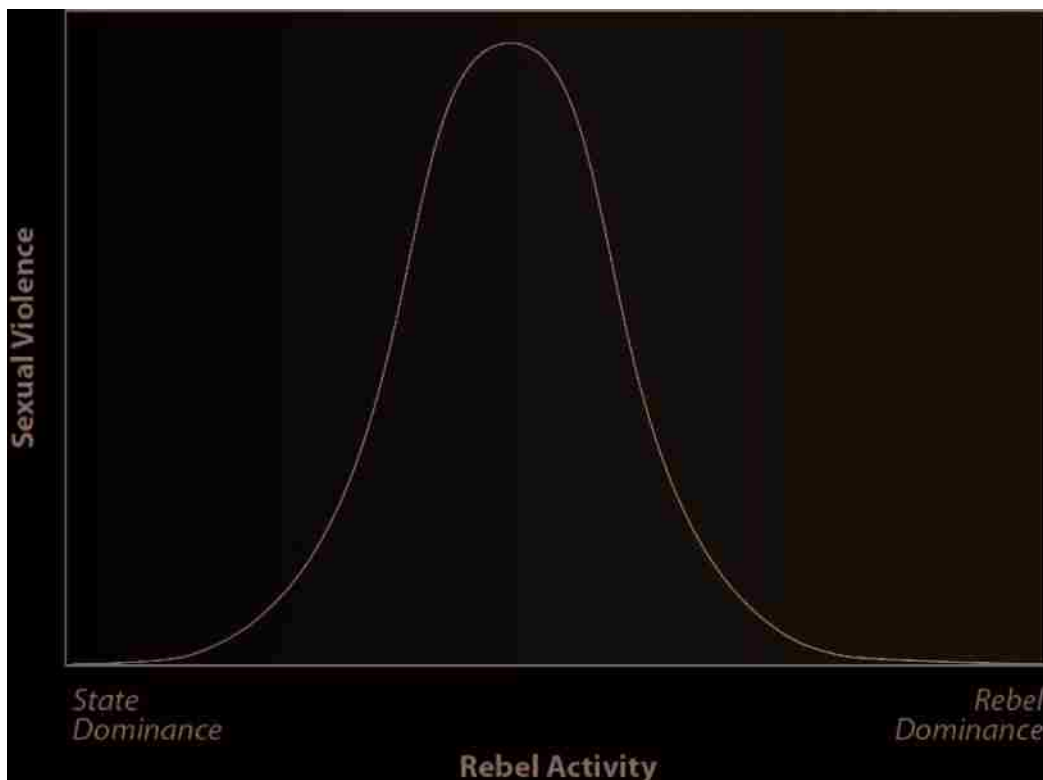

**Figure 2.1 Expected Relationship between Rebel Activity and State-Perpetrated Sexual Violence**

Most of the literature on violence and repression during civil war has assumed that different types of wartime violence are positively correlated with one another. For example, many scholars assume, either explicitly or implicitly that lethal acts of violence (battle-related deaths, murders and disappearances) are positively correlated (Kalyvas

2006, Weinstein 2007). However, little work has been done to disaggregate the different forms of wartime violence and to theorize in what ways they may be (un)related. Doing so will provide significant insight into the underlying causes of wartime sexual violence and other forms of political violence.

In this way, state-perpetrated sexual violence is highly correlated with other forms of violence. Sexual violence is conceptualized as a subset of state repression that is employed strategically and alongside other abuses in order to weaken the armed opposition. Thus, sexual violence should co-vary spatially and temporally with other forms of political violence, such as extrajudicial killings and torture. This is an empirical question that has not yet been explored. Answering it will give significant insight into the underlying causes of these war crimes.

<b>Theoretical Hypothesis</b>	Sexual violence (and other forms of political violence) is carried out for strategic (group) reasons when the state is faced with a threat to its national security		
		<b>Literature</b>	<b>Tested Here?</b>
<b>Testable Hypothesis</b>	There is effective command control within the state security apparatus		N
	Sexual violence will increase in times of war	Butler et al. 2007 Green 2006	N
	Sexual violence will be higher at times and in places where rebel activity is moderate	Leiby 2009a	Y
	Sexual violence will be low at times and in places of little rebel activity		Y
	Sexual violence will be low at times and in places where contestation is high; sexual violence will correlate negatively with battle-related violence		Y
	Sexual violence will be low at times and in places where the state maintains control	Ron 2003	Y
	Sexual violence will correlate over time and across space with other forms of non-lethal counterinsurgency violence	Leiby 2009a Wood 2010	Y
	Sexual violence will be targeted against “opponents of the state,” those deemed to pose a threat to national security	Leiby 2010	Y

**Table 2.2 Model of Wartime Sexual Violence as a Method of Counterinsurgency Warfare**

The hypotheses outlined above do not necessarily differentiate between opportunistic and strategic sexual violence. Opportunistic violence may also occur in

areas where there are rebel bases or where there are frequent battles simply because more soldiers are stationed in these zones and have access to the civilian population. However, we can begin to discern the state's interests by examining its messages regarding the war and the opposition as well as the importance of protecting human rights in speeches and the training of the armed forces. How does the state communicate its goals to soldiers? How does the state frame the opposition? I hypothesize that when national security doctrine employs a broad conception of "threat" that essentializes and dehumanizes the opposition sexual violence will be more prevalent and indiscriminate. We can further identify the interests of the state by their responses to reports of human rights abuses. If sexual violence is opportunistic in nature and the state does not want it to occur, allegations of abuse will be promptly and adequately investigated and when the necessary information is obtained, offending soldiers will be demoted or discharged from service and prosecuted.

## **Conclusion**

In this chapter, I presented the debate between opportunistic and strategic accounts of wartime sexual violence. By focusing on the micro-patterns of sexual and other forms of political violence – how and by whom it is perpetrated, where and when it is perpetrated, and against whom it is targeted – I outlined the hypotheses to test the causal mechanisms of the opportunity and state strategy models. Next, applying the literature on state repression to wartime sexual violence, I presented a new theory of sexual violence as a military strategy in counterinsurgency wars. This theory is not universally applicable; it should be seen as offering *one* of several possible causal mechanisms of wartime sexual violence. It is most applicable to explain state behavior in

interstate and intrastate conflicts where both state and non-state armed groups engage in irregular warfare.

The following chapter presents the data on sexual and other forms of political violence used to measure the dependent variable in this study. The conceptualization and operationalization used in this study are discussed in detail as they impact the findings presented in Chapters 4, 6 and 7.

## CHAPTER 3

### DATA ON WARTIME SEXUAL VIOLENCE

Research on wartime sexual violence is faced with unique practical, ethical and methodological obstacles. Perhaps the greatest of these is the systematic measurement and collection of data on its existence. This chapter discusses the challenges of collecting and coding data on wartime sexual violence and offers suggestions for overcoming them. It introduces the sources of data used throughout the study and the construction of a new database on political and sexual violence in Peru and El Salvador.

#### **Data Availability and Victim Underreporting**

The greatest impediment to advancements in our understanding of sexual violence is the absence of systematic data on its occurrence. The limitations of the data come from victims' reluctance to report sexual crimes as well as institutional decisions that lead to underreporting the true prevalence of sexual violence.<sup>24</sup> The factors that lead to the relative (under)reporting of sexual violence vary over time and across societies and groups of people within those societies. As a result, caution should be taken when interpreting statistics on wartime sexual violence, as observed variation in its prevalence and patterns of perpetration may simply be the result of differential biases in its documentation.<sup>25</sup>

---

<sup>24</sup> Throughout the dissertation, the terms victim and perpetrator are used to refer to attributions of identity at a particular moment in time as it relates to the violation of an individual's human rights. These identities are fluid and dynamic, as are the concepts of "innocence" and "guilt." The same individual that may at one moment be an agent of violence, and thus a perpetrator, can at another moment be a victim of human rights abuse. Particularly with regard to sexual violence, my use of the term "victim," is not intended to reinforce the stigma of an individual who has suffered sexual violence, nor is it to deny or minimize the agency, power and resistance of the person.

<sup>25</sup> In this chapter, I will make reference mostly to the factors that lead to the underreporting of wartime sexual violence. However, there are some who warn of the risk of overreporting that results from the misguided efforts of individuals who lodge false complaints of sexual violence or non-governmental organizations who misrepresent statistical evidence in order to raise international attention and resources to



Survivors of sexual violence, whether in conflict situations or in times of “peace,” rarely report the offense to authorities. In the U.S., for instance, it is estimated that only 26 to 36 percent of all sexually motivated crimes are reported to the police (Rennison 2002). Reporting sexual offenses varies greatly across countries and cultures, the sex of the victim, and the type of sexual crime. In societies where patriarchal norms are particularly strong, survivors may be disinclined to report sexual offenses because they feel ashamed or fear being blamed, stigmatized and isolated from their community.<sup>26</sup> After being raped by a Lieutenant from the military base, who she characterized as “crazy looking for women in the community,” one victim described her pain: “... I was suffering and I wished the ground would open up and swallow me to end my embarrassment. Because of the shame, no one knows about this, only myself and my husband” (CVR testimony 200920).

In Peru, Andean culture is based on mutually supportive relationships and reciprocity. Couples’ social recognition or prestige within the community is relative to their combined contributions to community life. “In the Andean world, “being two” is part of what it means to be a community member and a peasant” (CVR Tomo VIII 2003, 75; author translation). One woman, married with six children, relates her experience and the trauma she suffered after discovering she was pregnant from her rapist:

---

this humanitarian crisis (Isikozulu and Millard 2009). This study relies on the direct testimony of victims and survivors of violence. I have never come across a case in either of the two research sites where the veracity of a victim’s testimony of sexual violence has been called into question. It is conceivable that an individual could falsely claim to be the victim of rape (or any other human rights violation) if they believed that such a claim would result in their receipt of financial reparations. However, given the strong stigma against victims of sexual violence and the abundant evidence of victims’ silence regarding these crimes, it is unlikely that there exist a significant number of false allegations in my dataset.

<sup>26</sup> While most discussions of rape statistics focus on the pervasive underreporting issue, it is also possible for false reports to be injected into the data. This is of greater concern in political conflicts where either side may encourage the intentional fabrication and reporting of abuses to human rights agencies to demonize their opposition. Because of the high costs to individuals and the stigma attached to rape victims, I do not expect this kind of over-counting to affect my data on sexual violence.

A husband knows when he can get you pregnant and when he can't. My period didn't come and I said nothing until I told him and he was surprised because he had calculated the days. Weeping and in pain, I told him what happened and since then I have lived a terrible hell. Having been abused, my husband who was drinking all the time, insulted me, saying I was a whore.  
(de Fernandez and Wurst 2007, 171)

Similarly, another woman recounts how she was rejected and abandoned by her husband after he discovered she had been raped. On multiple occasions, unknown armed men wearing ski masks raped her in her home. She never went to the police and did not report it to any human rights organizations out of fear that she or her family would suffer more. When her husband found out that she was pregnant as a result of the rapes, he left her. The victim describes how her family fell apart. Her husband remarried and abandoned her and their two children (CVR testimony 203354).

Similar norms governing gender and sexual relations can be found in El Salvador, where both men and women's beliefs regarding sexual violence are laced with moral judgment and prejudice. Victims are often blamed for conducting themselves in a way that put them at risk for sexual assault (Hume 2004). Although fictional in nature, the short story, "La Honra," accurately captures the attitudes that still dominate Salvadoran society today. In the story, a young peasant girl, Juanita, was raped while bathing at a water hole near her home. She ran home, crying. When she told her father what happened, he lashes out at her with contempt and disgust: "why were you so stupid to have lost your honor; how could you lose the only valuable thing you had?" (Salarrue 1999, 10).

Victims may also anticipate ineffective or unsupportive responses from the authorities. The police may be unable or unwilling to adequately protect victims of sexual violence and prosecute their offenders. This is of particular concern in conflict

situations where state security agents bear responsibility for many sexual violations. In such cases, survivors may fear retributive violence if they report the crime and denounce the perpetrator.

One deponent in Peru recounts how she told the soldiers at the barracks about the rape of her cousin by members of the *Movimiento Revolucionario Túpac Amaru*, MRTA (Tupac Amaru Revolutionary Movement):

. . . . The soldiers told her that her cousin should come to the barracks to help them find the perpetrators. When she arrived, her hands and feet were tied. She was beaten and thrown on top of a desk and *offended* by one official and five soldiers. The deponent told her cousin that she shouldn't say anything to anyone about what happened.

(CVR Testimony 300578; italics were added)

A review of testimonies collected by the CVR in Peru revealed that 31 percent of all human rights violations were reported to state security authorities or a human rights or assistance agency. While impossible to isolate the reporting rate of sexual crimes from other human rights violations, I suspect it to be much less. The most commonly cited reasons for not denouncing a crime include: fear (76%), a sense of futility and disillusionment in the justice system (10%), because the individual did not know how (either due to age, literacy or unfamiliarity with the system) (9%), and a lack of resources (time and/or money) to travel to the appropriate institution (3%), etc.<sup>27</sup>

Even if victims are willing to report acts of violence, war-torn societies may lack the necessary resources and infrastructure to do so. Roads and bridges may be destroyed, making travel more difficult. Hospitals, community organizations, and police stations may have been bombed, and personnel killed. Access to social services is not uniform within societies. Disadvantaged populations, whether based on socio-economic class,

---

<sup>27</sup> The interview and information collection process for human rights organizations in El Salvador differed from those of the CVR in Peru. As a result, similar reporting statistics are not available in El Salvador.

race, ethnicity or geography, often experience greater difficulty in accessing state institutions and services. As judicial and political authorities in Peru and El Salvador fled the violence in rural communities and relocated to departmental capitals, those without the resources to travel the hours or days necessary were left with no representation or contact with the state.

Individuals living in the most rural and isolated communities may have no awareness of the activities of aid organizations and/or possess intense skepticism and distrust of “outsiders.” This was a prominent concern of the truth commission in Peru. Before dispatching its teams of investigators, the CVR sent volunteers to outlying communities to establish a rapport with community members and familiarize them with the objectives and work of the truth commission (Salcedo 2009). To the extent that such subgroups within the population are affected by political and sexual violence differently, unequal access to reporting mechanisms may distort not only the overall level of violence reported, but also the types of violations and patterns of violence reported.

There are some measures that can be implemented to encourage victims of sexual violence to come forward, such as guaranteeing victims’ anonymity, creating special female police units to handle cases of sexual abuse, increasing protective services, and providing physical and mental health services to victims. For the most part, however, such initiatives are beyond the purview and capabilities of social science scholars. In the section below, I discuss a number of decisions that researchers make, often without thoughtful consideration, and the consequences they have on data and findings on wartime sexual violence.

### **What Is Sexual Violence: Legal Statutes and Social Norms**

Concept formation is central to the research process. It is inextricably linked to theory building, operationalization, of variables, and measurement (Goertz 2005). Despite this, social scientists often pay insufficient attention to conceptualization in their analyses. Studies of sexual violence are no exception. What is understood as sexual violence varies widely across ethnic, religious, and social groups. For example, not all societies recognize marital rape as a criminal offense. Cases where the victim's body does not show obvious signs of a violent attack, where the perpetrator did not use a weapon to coerce the victim, or where sexual violence is perpetrated to restore family honor may not be prosecuted (Rozée 1993). How institutions and researchers define the parameters of sexual violence determines which offenses are "counted" and how statistics on their reported frequency should be interpreted.

How societies define and codify sexual offenses in national penal codes greatly determines how individuals conceptualize such acts and ultimately whether they are reported to the police.<sup>28</sup> In their 1980 study based on the U.S., Skelton and Burkhart found that the most significant factor affecting a victim's likelihood of reporting sexual abuse was whether s/he understood what happened to be a crime, an issue complicated by changing cultural norms and legal statutes of domestic and sexual violence. However, national laws do not affect only the victim's perceptions of sex relations and violence; they also shape the attitudes and beliefs of those who document and prosecute criminal offenses. In her study of wartime rape in Peru, Boesten found that legal codes strongly shaped the perceptions of the survivors of rape, their family members, and those working

---

<sup>28</sup> For example, both men and women will be less likely to report sexual assaults when by doing so they may risk criminal charges and punishment. In societies where adultery or engaging in homosexual activity is illegal, male and female rape survivors may avoid reporting the crime when they fear they will be unable to demonstrate that they did not consent to the sex act, which is necessary to prove that they themselves did not break the law.

for the CVR (2007).

The following interview excerpt from an interview by a CVR staff member discusses the case of Anna,\* a fifteen-year-old girl raped by a soldier stationed at the military base in her community. At the behest of her mother, Anna later signed a contract saying that she had sexual relations with the soldier and that she would marry him. After subsequent sexual relations, Anna discovered she was pregnant and gave birth to the soldier's baby. The case is illustrative of the social, cultural, and legal understanding of rape, consent, and violence from the perspectives of Anna, her mother, the captain of the military base who arranged for the marriage contract, and the CVR interviewer.

*Interviewer:* So it is more probable that you, that your daughter who was born on 18 October was, well, was born as a result of the sexual relations that you had with your husband, with your consent, in January. That would make for the nine months, which it normally takes in pregnancy, is that not true *mamita*? When I took your declaration earlier, you did not tell me this. You said that as a result of the rape, you had a baby; that is what you said. And your daughter was not born as a result of this rape, as we were discussing earlier, rather, she was conceived later, when you had relations with your consent, when there was no violence, is that not true? So that means that there was no violence involved in conceiving your child, so why did you tell me that she was the product of violence?

*Anna:* But if it was not for this rape, I would not have had my daughter.  
(CVR 2003, 30-31, 402-403)

Signing the contract not only changes the social and legal understanding of any subsequent sexual relations Anna and the soldier had; it works retroactively as well to declare the original act legal and consensual in the eyes of the state and community. The sexual act that resulted in the birth of Anna's daughter was framed as consensual and nonviolent, despite the highly coercive and violent context within which it occurred. It is clear from the excerpt above that human rights organizations, truth commissions, and

---

\* Throughout the dissertation, the names of all victims, witnesses and accused perpetrators of violence are replaced to protect their identity.

international criminal tribunals cannot assume that their investigators share the same understanding of sexual violence.

At the time of Anna's case, the Peruvian Penal code allowed individuals accused of rape to avoid prosecution and punishment if they proposed to marry the victim (Merino 1997). In cases of gang rape, all of the alleged perpetrators would be exempt from punishment if the victim agreed to marry one of them (Código Penal XI(178)). In 1997, Congress repealed the law, but still maintained that criminal charges would be withdrawn if the issue was resolved "privately" (Sharlach 2001). Subsequent testimonies collected by the CVR revealed individuals' uncertainty in identifying rape cases and reluctance to denounce them as crimes due to changes in national rape statutes.

El Salvador, on the other hand, has had a stable legal tradition with respect to rape and other sexual violence cases. Rape is defined as "any form of violence in which there was penetration of the vagina or anus by another person" and is punishable by 6 to 10 years in prison (Código Penal 1997). Other forms of sexual aggression that do not meet the requisites of rape are sanctioned with 3 to 6 years in prison (Código Penal 1997).<sup>29</sup> Accordingly, victims of sexual violence in El Salvador may be more likely to view their experiences as criminal acts, to report them to the police, and seek judicial reparations than their counterparts in Peru, *ceteris paribus*.

Related, the cultural norms regarding sexuality, purity and gender strongly affect *how* survivors describe the violence they suffered. Particularly in native communities, it may be considered highly inappropriate for women to talk about their bodies, sex or violence. As a result, women (and men) avoided the use of direct language to describe the assault. The Spanish word for "to rape" (violar) was rarely used. Instead, roundabout

---

<sup>29</sup> Prison terms for rape or other sexual crimes against a minor are longer.

phrases or words such as “they bothered me” (me molestaron, fastidiaron), “they were with me” (estuvieron conmigo), “they harassed me” (me acosaron), “they abused me” (me maltrataron), “they took me” (me sacaron), “they did ‘el largo’ to me,”<sup>30</sup> “they took advantage of me” (me aprovecharon), or “I surrendered” (capitulé). One woman simply said: “I didn’t have the strength to defend myself. I was really *affected*” (CVR Testimony 700906, emphasis added). The literal translation of these words and phrases may not point to acts of sexual abuse. However, by examining the context within which they appear, such as the removal of the victim’s clothing or indications of subsequent health problems, researchers can usually determine the intended meaning of the speaker.

For example, a woman in Ayacucho who was accused of participating in subversive activities was subjected to repeated detentions and torture. In 1984, she was detained and transferred to the military base in Cangallo. The soldiers asked her about her involvement in a previous attack that resulted in a number of deaths, including a few soldiers. She denied participating in or knowing anything about the event. She was later transferred to the *Policía Investigativa de Perú* (PIP; Peruvian Investigative Police), where she was repeatedly interrogated by an officer (identified by name). After being released, the officer continually broke into the woman’s home, beating and “bothering” (from the verb *molestar*) her. As a result of these events, the victim reported to the Commission having chronic pain in her ovaries (CVR 201476). Other women would describe their “condition as women” or their “dignity” or how a neighbor suddenly changed, became withdrawn, or had trouble with her husband.

---

<sup>30</sup> “El largo” refers to a process whereby soldiers rub their weapons against the body of the victim, who is often blindfolded to intensify the fear and anticipation of the violence, and then rape him/her with the weapon.



Similarly, the norms regarding masculinity and heterosexuality complicate the meaning of sexual violence. Men are less likely to report sexual violence and less likely to describe it as *sexual* violence if it threatens their identity as strong, capable, virile, heterosexual men.<sup>31</sup> “Societies’ constructs of masculinity play an important role in...non-reporting. Society often equates manhood with ‘the ability to exert power over others, especially through the use of force.’ Thus, victimization and masculinity may be considered incompatible in the belief that men cannot be victims” (Sivakumaran 2005, 1289). Moreover, there is what Sivakumaran calls the “taint” of homosexuality for the victims of male/male rape (2005). Victims of male/male rape often question their own sexuality after the assault. According to surveys cited by the author, victims of male/male rape often report wondering if they possessed a certain homosexual trait that attracted the perpetrator to them (Sivakumaran 2005). Failure to recognize such cultural constructs of victimhood, masculinity and sexuality can result in the underreporting of sexual violence against men.<sup>32</sup> Scholars and policy makers believe that the majority of victims of sexual violence are women and girls. However, the proportion of male to female victims can change according to how sexual violence is understood and recorded.

Confirming the finding that many men were subjected to sexual violence during the Salvadoran civil war, a survey of political prisoners at La Esperanza men’s prison

---

<sup>31</sup> The underreporting of male sexual violence may be further compounded in ethno-nationalist conflicts in which the power of the state is symbolically linked to images of the virility, power, and heterosexuality of its men. For instance, despite evidence of rape and castration of men in camps in the former Yugoslavia, the Croatian media reported only one story of male sexual violence – the rape of a Muslim man. There was no mention of Croatian men either having suffered sexual violence or having perpetrated it during the conflict. The image of a powerful and righteous state is defended through the denial or suppression of stories of Croatian men having been the object or perpetrator of sexual assault (Zarkov 2005).

<sup>32</sup> Del Zotto and Jones (2002) examined the informational materials of 4,076 non-governmental organizations that address sexual violence in conflict situations and found 1.4 percent of the reports expressly framed the issue as one that affects only women and girls. An additional 25 percent of the organizational literature denied that sexual violence against men and boys was a problem. Only 3 percent of the materials specifically mentioned the experience of male victims and survivors of sexual violence.

(commonly known as La Mariona) revealed that 76 percent had suffered sexual abuse during their incarceration (CDHES 1986).<sup>33</sup> Another study found that men were often kicked, punched or beaten on their testicles with guns or sticks as a form of punishment or coercion during detention and interrogation (Carlson 2005). While similar beatings on other parts of the body were a common experience in detention and reported as such by human rights groups, few activists, medical care providers or victims interpreted the specific genital attacks as *sexual* torture or assault.<sup>34</sup>

The following case illustrates a common pattern of sexual torture against men in El Salvador. A young man, age 23, was waiting at a bus stop when an unmarked car pulled up and six armed men in civilian clothes approached him. They threatened to shoot him if he ran or made a scene. They pushed him into the car, blindfolded him and took him to what he later discovered was the *Polícia de Hacienda, PH* (Treasury Police) in San Salvador. While detained, the man was interrogated and tortured in an attempt to extract a confession of his affiliation with the guerrillas. He was forced to do exercises, beaten all over his body, including his testicles, until he passed out. The police doused him with cold water to revive him, and repeated the process. He was ultimately forced to sign blank papers (presumably a “confession” used as evidence of his guilt) and then transferred to Mariona prison (Tutela Legal 1986, CV-3700). From the case description, it appears that genital beatings were one of several repressive techniques used against

---

<sup>33</sup> Most incidents of sexual violence occurred before the detainee was transferred to Mariona, while in the custody of state security agents.

<sup>34</sup> Carlson (2005) believes that victims’ and researchers’ reticence to categorize blunt trauma to the male genitalia as sexual torture is related to “peacetime” conceptions of similar episodes. He writes: “...being hit in the testicles during peacetime activities is generally considered a ‘normal’ occurrence. For example, men’s testicles are hit in soccer, American football and in many other contact sports, where players are expected to ‘take it like a man.’ Some martial arts instructors even purposely hit their students in the testicles as a form of punishment, and some college fraternities have been known to pour hot wax on their pledges’ testicles as a form of initiation. Furthermore, a woman kicking a man in the groin has become a stereotyped form of sexual rejection...” (20).

suspected guerrillas and not necessarily distinct in motive. To determine if this is true of all forms of sexual violence perpetrated against both men and women throughout the civil war, researchers must distinguish sexual violations from other human rights abuses so that their patterns of perpetration may be compared and their distinct motivations (if any) identified.

Preliminary research evaluating both the published records as well as primary documents of the CVR reveals that the percentage of male victims of sexual violence in Peru is higher than commonly expected *and* higher than previously reported.<sup>35</sup> Rather than the 2 percent cited in the Commission's final report, I found that 29 percent of events of sexual violence listed in the published annexes of the report included male victims (Leiby 2009a).<sup>36</sup> My work in the archives, accessing the original victim and witness testimonies, similarly indicates that 29 percent of victims of sexual violence were men. One reason for the discrepancy between my and the CVR's figures is our different conceptualization and operationalization of "sexual violence." While defining sexual violence broadly to include such abuses as forced prostitution, forced marriage, sexual slavery, forced abortion, forced impregnation, rape, and sexual torture, the CVR investigated and reported only cases of rape and made only occasional references to other

---

<sup>35</sup> There was only one case of sexual violence against a man reported by the CVR. The case does not appear exceptional in any regard that would indicate its inclusion in the CVR's database when similar violations were excluded. In this case, the victim describes how he was attacked two years after his father, sister and two others were killed by the military. He was at a party at a relative's house and was intoxicated. The military arrived. They entered the house and captured the victim, putting a hood over his head and tying his hands behind his back. They detained him at a military base, where he was tortured for 10 days and violently raped (CVR *Informe Final*, testimonies 407532 and 425187).

Other studies have found that in Liberia and Sierra Leone, men were also subjected to sexual violence (Johnston, et.al. 2008; Cohen 2007).

<sup>36</sup> This study was conducted using the published annexes of the Truth Commission. They are available on the CVR's website at <http://www.cverdad.org.pe>. The annexes provide very brief descriptions of cases presented to the Commission. I read each summary and collected data on events of sexual violence. An "event" can include multiple victims, violations and/or perpetrators. I recorded 695 events of sexual violence, and 913 individual sexual violations. Of the 695 events, 30 percent included male victims (25 percent of these included only male victims and 5 percent included both male and female victims).

forms of sexual violence in the narrative of its final report. As a result, the Commission overlooked the multiple ways in which men and women were sexually victimized.

Examining the primary documents shows that the most frequent form of sexual abuse suffered by men was sexual humiliation (54 percent) followed by sexual torture (18 percent), sexual mutilation (13 percent), and rape (7 percent).<sup>37</sup>

Security forces, for instance, often used electricity applied to the genitals to punish or elicit information or a confession from male detainees. Linking the testimonies with the CVR's database reveals that sexual torture against both men and women is often coded as torture.<sup>38</sup> The rape of men is treated inconsistently— coded as either sexual violence or torture, and sometimes not recorded at all. Sexual violence perpetrated by non-state actors was also misleadingly documented. A common tactic employed by the Shining Path to punish men suspected of betraying the revolution was to forcibly strip them in public and remove their testicles and/or penis. Failing to report such abuses as *sexual* violence, or failing to report them at all, misrepresents the nature and patterns of violence during the war.

Consider the following example. In February 1984, a group of thirty soldiers entered and searched the home of a suspected member of the Shining Path. While interrogating the suspect's grandmother, the soldiers severely beat her and burned her vagina and anus. They later poured kerosene on her body and set her on fire. The soldiers also beat and interrogated the suspect. They accused him of terrorism, stripped

---

<sup>37</sup> Of the cases of sexual torture against men, two-thirds are beatings of the victim's genitals, which some may argue should be excluded as a form of *sexual* torture and characterized as just torture. It is conceivable that the motive behind such abuse is to cause the victim pain, rather than to attack his sexual or gender identity.

<sup>38</sup> Individual testimonies can be matched to observations in the database according to the testimony number, the event number, the observation number and the victim ID number.

him, and cut off his penis (CVR *Informe Final*, testimony 201443). The CVR's database (*Base de Datos de la CVR*, herein referred to as BDCVR) captures the detention and torture of each victim. However, neither the sexual torture of the grandmother or the mutilation of the grandson were recorded as sexual violence. Each act was coded as torture. I argue, however, that these forms of violence are qualitatively different from other forms of torture. They attack the victim's gender and sexual identity, cause deep physical and psychological scars, and degrade and humiliate the person in ways that beatings, water boarding, or other forms of torture do not. In addition to being used to punish or extract information from individuals, sexual torture also may be used explicitly and perhaps solely for the purpose of attacking and destroying the individual's sense of self as a man or woman, a father or mother, or a spouse.

A similar comparison of the primary and published records of the CVES, Tutela Legal and Socorro Jurídico is not possible because none of these institutions conducted an analysis of sexual violence during the war. However, it is unlikely that these institutions, working in a less gender-sensitive context, would have done a better job than that of the CVR in Peru.

Scholars of wartime sexual violence need to understand the legal statutes and socio-cultural norms regarding sexual abuse that operate within the country. They influence not only what survivors of sexual violence are willing to report to investigators, but *how* they report it as well. Care must also be taken to adequately train investigators so that their own perception and internalization of these norms does not interfere with taking a witness or survivor's statement. Because these nuances will vary across

countries and cultures, investigations of wartime sexual violence must be rooted in case-based knowledge and sufficient field experience at the research site.

### **Creating Analytical Concepts**

The academic and policy literature has similarly struggled with conceptualizing and operationalizing sexual violence. Much of the literature either poorly specifies the dependent variable or limits it to rape and gang rape (Cohen 2008; Green 2006 and Sharlach 2001). Green observes incidents of “collective rape,” which she defines as “a pattern of sexual violence perpetrated on civilians by agents of the state or political civil group” (Green 2006, ii). Sharlach uses rape and sexual violence interchangeably and defines them as “any sexual penetration of a female by a male (or with an object) that takes place without her consent” (2001, 11). The dependent variable of her study, however, is a state’s “rape policy,” which can range from the state’s use of rape as an act of genocide, torture, or terror, to its failure to prosecute rape perpetrated by civilians, or the state’s due diligence in prosecuting and preventing rape (Sharlach 2001, 7-8). While each author defines the dependent variable, these are concepts not easily operationalized or empirically measured. Moreover, they are limited to acts of penetrative rape, and in the latter case, only when perpetrated against a woman by a man. The decision to focus exclusively on cases of rape may be driven by the limitations of the data. While there exists ambiguity across and within societies about what constitutes rape, it is more easily identified than other forms of sexual violence.

Collecting data on the various forms of sexual violence requires corresponding definition and operationalization. Isolating the unique attributes of different sexual abuses is not easy. What constitutes sexual torture and how does it differ from sexual

mutilation? Should forced nudity be considered sexual violence? These are questions without straightforward answers. The International Criminal Court (ICC) recognizes rape, sexual torture and mutilation, sexual slavery, enforced prostitution, enforced sterilization, and forced pregnancy in its definition of sexual violence as a war crime and/or a crime against humanity. The ICC does not recognize sexual humiliation or attempted acts of sexual violence as a war crime (ICC 2000).

In the interest of creating social science concepts to be used in analyses of the underlying causes of wartime sexual abuse, I argue for a broader interpretation of sexual violence than is currently used by the ICC. Here, the term includes all forms of sexual violence recognized by the ICC, and adds sexual humiliation and sexual coercion. I hypothesize that armed groups that commit rape, mutilation, and other forms of sexual violence recognized by the ICC also will be inclined to use sexual humiliation and coercion.<sup>39</sup> Therefore, understanding the causes of one may help us to understand the causes of all forms of wartime sexual violence.<sup>40</sup> Collecting data on the varied forms of sexual violence and maintaining the disaggregation of these violations will allow researchers to examine additional hypotheses regarding the perpetration of sexual violence during war. While I argue for the use of a more expansive conceptualization of wartime sexual violence, I also analyzed all descriptive and inferential statistics using the

---

<sup>39</sup> Some of the same causal processes, such as a disdain for women and societal disregard for their rights, could explain both armed groups' willingness to perpetrate rape and other forms of sexual violence on the "battlefield" and the forced sterilization of women by health care professionals, policymakers, and others in the health care community. Others, such as how these social norms are imbedded and transmitted through military institutions, and how state armed forces frame their national security and react to threats to it, are distinct and require separate analysis. I will discuss the sterilization program of Alberto Fujimori's governments in greater detail in Chapter 5.

<sup>40</sup> This is a hypothesis that needs to be tested. It may be the case that even those forms of sexual violence recognized by the ICC – rape, sexual slavery, forced prostitution, forced pregnancy, forced sterilization, and mutilation – occur under different behavioral constraints and institutional contexts. Similarly, groups that engage in one or more of these abusive practices may not use them all.

parameters established by the ICC. Any significant changes that affect the interpretation of the results will be highlighted.

I adopt the ICC's definition of rape, as outlined in Article 8(2) (e) (vi) of the Rome Statute: "the invasion of the body of a person by conduct resulting in penetration, however, slight, of any part of the body of the victim or of the perpetrator with a sexual organ, or of the anal or genital opening of the victim with any object or any other part of the body" (ICC Rome Statute 2000). Gang rape, then, is any rape perpetrated by more than one person. I only coded a rape as gang rape if it was clear from the testimony that more than one perpetrator actively participated in rape of the victim. This includes cases where multiple, but an unspecified number of, persons committed the act: "*Las terroristas me violaron/The terrorists raped me.*" Both the subject and the verb of the statement suggest more than one perpetrator participated in the rape. Testimonies of events involving more than one victim and violation are complex. Often the details of each case are lost or aggregated. Therefore, I only coded reports of multiple rapes against multiple victims by multiple perpetrators as gang rape if the testimony indicated more than one perpetrator was involved in each attack against each individual victim. The following hypothetical case would be recorded as rape, not gang rape: "*Los soldados abusaron varias mujeres de la comunidad/The soldiers raped various women in the community.*"

Although usually involving multiple and repeated rapes, sexual slavery and forced marriage are conceptually distinct. The ICC defines enslavement as "the exercise of any or all of the powers attaching to the right of ownership over a person," and includes "the exercise of such power in the course of trafficking persons, in particular women and



children (ICC Rome Statute Article 7 (2) (c) 2000). Sexual slavery is described as “when women and girls are kidnapped against their will and converted into the property of one or more people who demand sexual services from them, and often other forms of domestic service as well” (Callamard 2002). Forced marriage can take many different forms, including when fathers or other guardians give a woman to be married without her consent or ability to refuse. I included sexual slavery and forced marriage as a separate analytical category and assigned it a distinct code in the database. However, I found no reports of either crimes during the civil wars in either El Salvador or Peru.

Following the United Nations Special Rapporteur on Torture, I argue that any form of sexual violence that causes severe pain and suffering to the victim, whether physical or psychological, should be considered sexual torture. Sexual torture can, but does not always, result in permanent damage or scars that affect future sexual function. Beyond the physical pain inflicted, often the purpose of sexual torture is to attack and destroy an individual’s identity as a man/woman, sexual partner, parent, etc. It can be perpetrated during interrogation to intimidate or punish the victim, obtain information, or coerce a confession from the victim or a third party (UN 1999 E/CN. 4/1992/SR.21). The Inter-American Commission of Human Rights (IACHR) further argued that in accordance with Article 5 of the Inter-American Convention on Human Rights, sexual offenses do not have to be perpetrated in official centers or institutions in order to be considered torture.

In the case of Fernando and Raquel Mejía versus the Republic of Peru, the IACHR found that the rape of individuals in their home by state security agents was an act of torture (IACHR 1999). This decision was significant in recognizing the environment in which irregular and counterinsurgent conflicts are often fought. To create mutually

exclusive categories of sexual violence, I use *sexual torture* to refer to those abuses that satisfy the criteria for torture, but which are not covered in the ICC's definition of rape (UN 1994). This includes, but is not limited to, the application of electricity, beatings, or other injuries to the breasts, genitals, and in the case of pregnant women, the abdomen. These acts of violence need not result in permanent sexual dysfunction or even visible bruises or scars to constitute sexual torture. Physical assaults to the breasts or genitalia always involve an attack on the individual's sexual identity by imbedding within the psyche of the victim an association between sexuality and fear, pain and violence (Agger 1986, Carlson 2005).<sup>41</sup>

To the extent that they are targeted against different population groups and occur in contexts different from rape, excluding cases of sexual torture will result in our misunderstanding the nature of wartime sexual violence. It may be, for instance, that rape is perpetrated more often while soldiers are dispatched in the field where supervising officers may have less control over their subordinate troops. Sexual torture (many forms of which are grotesquely elaborate and require access to specialized equipment) may be more common in detention facilities where perpetrators have more control over their environment and more time to plan and execute the crimes. Suggesting variation within the category of sexual violence, the CVR found that of the 118 individual testimonies collected from the Establecimiento Penal de Régimen Cerrado Especial de Mujeres de Chorrillos II (Women's Maximum Security Prison in Chorrillos) 96 inmates (81 percent) reported being the victims of sexual violence, but only 30 (25 percent) indicated rape as the offense (CVR 2003).

---

<sup>41</sup> State security agents have been reported to beat pregnant women's abdomens in order to induce labor or forcibly abort the fetus or otherwise damage the woman's reproductive organs.

Sexual mutilation, while similar, can be distinguished from sexual torture in that it involves the removal or permanent damage and scarring of reproductive organs, and may be accompanied by sterilization. In Peru, both the state armed forces and the Shining Path perpetrated sexual torture and mutilation. Moreover, these offenses followed different patterns of perpetration than rape. They were often carried out in public or during interrogation, targeted both men and women, and resulted in visible scars or signs of abuse, perhaps serving to terrorize others in the community (Leiby 2009a). The use of these offenses to send a message to a broader audience, combined with their brutality, warrants their treatment as a separate category of sexual violence.<sup>42</sup>

I define sexual humiliation as any offense of a sexual nature whose primary goal is to humiliate and degrade the victim, but which does not use direct physical force and which does not result in physical injury. Examples of sexual humiliation include compulsory nudity, stripping or dancing naked in public, and mocking an individual's genitalia. In societies where nudity is not the norm, the naked body is imbued with gendered and sexed meanings, suggestive of an individual's sexual availability, promiscuity and vulnerability. Being stripped and forced to remain naked has the intention of not just subjecting an individual to the elements (cold or rain), but of humiliating them, making them aware of their powerlessness and terrorizing them by provoking fears of an impending sexual assault. Examining the original testimonies collected by Tutela Legal and Socorro Jurídico reveals that sexual humiliation comprised 41 percent of all sexually based offenses during the Salvadoran civil war. Similarly,

---

<sup>42</sup> Publicity is not a characteristic unique to sexual mutilation. Rape and gang rape, sexual humiliation, and even sexual torture may, and often are, committed in public settings. In such cases, these other forms of sexual violence may also be used to terrorize entire families or communities, making their distinction from sexual mutilation less clear.

examining the original testimonies collected by the CVR reveals that 33 percent of all sexual violations in Peru were sexual humiliation.

Sexual coercion involves the threat of sexual violence to pressure or force individuals to do something against their will, such as inform on the political activities of a neighbor or confess to committing a crime. According to these definitions, the following would be categorized as sexual coercion and sexual humiliation.

On November 24, 1987, 60 soldiers arrived by helicopter and detained three people in the community of Nuevo San Miguel, district of Jepelacio, province of Moyobamba, department of San Martín. They gagged, bound and detained the victims at the local school. The soldiers hung and beat the three men on their backs with the butts of their guns. The soldiers then brought the men's wives and children into the school, stripped them and threatened to burn them alive. The soldiers also threatened to "abuse" the wives. One of the victims' faces was cut four times. Later, they were taken to the military base in Moyobamba where they were given food and attended to by doctors. . . . They were then taken to the base in Tarapoto where they were accused of belonging to the PCP-SL (Partido Comunista del Peru-Sendero Luminoso, Community Party of Peru-Shining Path). Finally, they returned to Nuevo San Juan and were freed on November 28, 1987.

(CVR Informe Final case 1012572)

The case is more complex than its presentation in the CVR database, which reports the three male victims as having suffered detention and torture. The men were not only subject to hangings and beatings. The soldiers intentionally used the sexual victimization of their wives and children (by forcibly stripping them) *and* the threat of further sexual violence (suggested by the use of *abusar*), perhaps to coerce the men to comply with their orders, or simply to punish them for their suspected subversive affiliations.

This was also a common strategy used by security agents in El Salvador to manipulate the civilian population. In one case, uniformed soldiers from the 2<sup>nd</sup> Infantry Brigade entered the offices of the agricultural cooperative during a military operation in Coatepeque, Santa Ana. They went first to the local agricultural cooperative, where they

captured five men, and then began to raid each house and detain those found inside. The soldiers gathered the men of the community together in the street and told them that they would not detain or *touch* their women if they answered their questions and agreed to cooperate (TL CV-7686). Threats of sexual violence against women may be particularly effective in coercing men to comply with the demands of their captors. Such threats attack a man's sense of self and expose his powerlessness and inability to protect "his" women in times of war.

Recording realized, attempted, and threatened acts of sexual violence gives the researcher a larger sample of cases to analyze the repertoires of violence of armed actors. Understanding in what contexts armed forces threaten or attempt sexual violence and how or why they were unable or unwilling to carry it out provides insight into the underlying causes of wartime sexual violence.

Understanding how victims and reporting agencies conceptualize sexual violence is crucial to understand exactly what is captured in reported statistics on sexual violence and its use in war. I am proposing one model here with specific definitions for various forms of sexual abuse, including types of violence that have not been recognized as human rights violations under international law. While some may draw the lines in different places, it is important to clearly define our concepts and open a dialogue in which the academic and human rights communities can build a consensus regarding what constitutes sexual violence.

### **Who Counts: Estimating the Number of Sexual Violence Victims**

After deciding what sexual violence is, human rights organizations and scholars must determine what constitutes a victim. One common point of disagreement is the

treatment of anonymous or unnamed victims. Both the truth commissions in Peru and El Salvador only collected data on victims identifiable by first and last name.<sup>43</sup> Including only named victims is a method commonly employed by large-scale database management projects. However, in studies and databases of sexual violence, there are likely to be numerous unnamed or unidentified victims. Because of the fear and stigma associated with being sexually violated, victims often report their attacks in the third person, as an event they witnessed or that happened to someone they know.

Despite, and perhaps due to, the reluctance of individuals to report personal sexual traumas, the CVR states that many of the testimonies it received make general reference to and provide stories of sexual abuse: “I heard that other girls had been raped, but not me” (CVR 700021). Working with the archived testimonies, I have been able to identify 249 incidents of sexual violence that were not included in the CVR’s database because the victims’ full name was unknown or withheld (there were 222 unidentified victims of sexual violence, some of whom suffered more than one violation). The most frequent forms of sexual violence against unidentified victims were rape and gang rape (56 percent), sexual humiliation (29 percent), and sexual torture, sexual mutilation and unspecified forms of sexual violence or the threat of sexual violence (5 percent each). Given the CVR’s operationalization of sexual violence as rape or gang rape, it is not surprising that the latter cases were not captured in the database.

If events of violence including unnamed victims are qualitatively different from those where individuals can be identified, excluding anonymous accounts may underestimate a particular subgroup within the population of victims – those who have

---

<sup>43</sup> The annex to the CVES’ final report includes victims by their first and last name, as well as those who were identified only by their initials. However, the report does not include any information on victims who wished to remain completely anonymous or who could not be identified by the deponent.

been attacked in the context of larger events of political violence where there were numerous victims. Massacres, battles between armed groups, or mass detentions are contexts particularly vulnerable to having “missing” victims of sexual violence. It may be the case that there are no surviving witnesses to the attack. Even if there are a few survivors, it may be that they do not know the names of everyone in the razed village. The massacre in El Mozote, Morazán in December 1981 is typical in this regard. The soldiers of the Atlacatl battalion separated the men from the women and the children of the community. The women were taken to the nearby hills where they were raped (perhaps gang raped) before all of the residents were systematically executed. The single witness to the event, Rufina Amaya Mírquez was 11 years old at the time of the attack. Until her recent death in 2007, Ms. Amaya repeatedly recounted the details of the massacre before the foreign media, heads of state and international human rights organizations. However, she did not know the number of women and girls who were raped, nor the names of all of those who were killed. It is common during community raids, massacres, and battles for there to be multiple, but an unspecified number of, unnamed victims. Excluding these cases from our analyses will bias our findings against identifying the patterns associated with mass, indiscriminate acts of violence.

Another illustrative case considers the use of sexual violence against members of subversive organizations, either by state armed actors or fellow comrades. Many scholars and policymakers implicitly or explicitly focus only on the sexual abuse of civilians. In many conflict situations it can be difficult and dangerous for human rights or aid workers to advocate for the protection of the rights of armed combatants or “terrorists.” However, sexual violence in war is *always* a crime and *always* a violation of one’s human rights.

Excluding these cases from our analyses not only distorts our understanding of the context and motives of sexual violence, but also reinforces the argument that armed combatants do not have rights.

Although officially prohibited, sexual violence, particularly forced marriage and sexual slavery, has been reported amongst the ranks of the Shining Path. Individuals sequestered or forcibly recruited by the Shining Path may have witnessed this violence and reported it to the CVR. Because it is a clandestine organization, little is known about the identity of individual members. Witnesses can provide little, if any, information on the victims' names, ages, family members, or where they lived. Rather than excluding all victims of violence who belong or used to belong to subversive organizations, I treat them as "unnamed Shining Path" or "unnamed MRTA" and record as many details about the event as possible.

When the deponent does not provide a specific number or some other quantitative descriptor of the number of victims, I record two victim-violation observations. Often witnesses will refer to "many," "a lot," or even "everyone" being subjected to political violence during a particular event. Also likely are statements such as "among those killed, was my husband." In these cases we know that more than one person died, but exactly how many more is indeterminable. Erring on the side of conservative estimate, while again risking mischaracterizing the level and patterns of violence, is warranted since we can make no reasonable judgment of the number of victims. Employing this strategy, I have identified a minimum of 224 cases of sexual violence against unknown



individuals.<sup>44</sup>

Adding unnamed victims to datasets of political violence introduces its own potential biases. In this case, there is a risk of distorting the patterns of violence by overcounting cases that are duplicated within the dataset. Most cases are sufficiently unique to allow duplicate records to be matched and eliminated based on the context and description of the violation, the sequencing of events, and where and when the event occurred. However, this presumes that victims and witnesses remember accurately and similarly the events. Even if we accept this as true, the matching process is time-consuming, difficult and imperfect. There is an obvious trade-off when making the methodological decision to focus on both named and unnamed victims of violence. At the very least, full disclosure of these tradeoffs is warranted.

### **Data Used in this Study<sup>45</sup>**

#### **El Salvador**

On January 16, 1992, the representatives of the Salvadoran government and the insurgent force, *Farabundo Martí para la Liberación Nacional*, FMLN (Farabundo Martí National Liberation Front) signed the Chapultepec Accords, ending 12 years of brutal violence and war. Both parties agreed to establish a truth commission, moderated by the United Nations, which would “investigat[e] serious acts of violence that have occurred since 1980 and whose impact on society urgently demands that the public should know the truth” (CVES 1993, 18). The *Comisión de la Verdad para El Salvador* (CVES) was

---

<sup>44</sup> That there were only two unidentified victims of sexual violence in El Salvador is likely due to the nature of the data. The denunciation reports filed by Tutela Legal and SJC do not reflect complete conflict narratives such as those collected by the CVES or the CVR in Peru.

<sup>45</sup> This section is organized temporally to maintain a sense of the historical progression in the methods and data collection procedures employed by human rights investigating organizations. As will be discussed, the abundance and quality of information on state-perpetrated sexual violence in Peru is far greater than that available in El Salvador. As a result, the remainder of the dissertation will present the Peruvian case first, and discuss El Salvador as a secondary test case.

also to issue recommendations to prevent future human rights abuses and to promote national reconciliation.<sup>46</sup>

As a UN-sponsored truth commission, the executive committee was governed entirely by internationals.<sup>47</sup> While all were well-respected leaders in their professions, the exclusion of national scholars and experts from the Salvadoran truth commission was a point of contention and sets it apart from its predecessors in Argentina and Chile as well as subsequent commissions, like that in Peru. The decision was made in large part to guarantee the commission's objectivity and impartiality and to overcome concerns that lingering insecurity would impede Salvadoran nationals' ability to frankly investigate and publish findings on their country's violent past. The CVES had an additional staff of 25 lawyers, sociologists and forensic scientists, but was still comparatively small in size for a truth commission (Hayner 2001).

The CVES was given six months (later extended to eight months) to complete its investigations and issue its final report. It began its work in July 1992. Announcements about the Commission's work flooded radio, television and print media outlets, encouraging all individuals, groups and organizations with information on acts of violence to testify before the Commission. Individuals could make statements at the Commission's main office in San Salvador or any one of its satellite offices, established in each department throughout the country. Individuals were reassured that all testimonies and procedures of the CVES were confidential. In the end, the Commission

---

<sup>46</sup> This was the first time the United Nations sponsored such a truth commission.

<sup>47</sup> Belisario Bentacur, a former President of Colombia, served as the Chairman with Reinaldo Figueredo Planchart, a former Foreign Minister of Venezuela and Thomas Buergenthal, a former Judge and President of the Inter-American Court of Human Rights, as members.

collected more than 2,000 testimonies detailing acts of violence against more than 7,000 victims and survivors.<sup>48</sup>

The truth commission in El Salvador did not investigate cases of sexual violence. It argued that because there was no evidence of orders or a policy of rape, such acts were apolitical, interpersonal violence and as such did not fall within its mandate (Hayner 2001). Because of this executive decision, the CVES did not define the parameters of sexual violence, and made no attempt to explain these violations in the narrative of its final report. This is true even for well-known cases where sexual violence was reported. In the case of four U.S. churchwomen who were kidnapped, raped and murdered in 1980 by the *Guardia Nacional* (GN, National Guard), the Commission reported, but did not investigate the motives behind, the rapes (CVES 1993). Another publicized case involved the kidnapping, torture and murder in 1982 of four Dutch journalists. In addition to other forms of torture and body mutilation, the victims also endured trauma to their genitals, which was not reported in the Commission's final report (Valencia-Weber and Weber 1986; Dutch Ministry of Foreign Affairs 1982). The Commission's disparate reporting suggests it had an implicit working definition of sexual violence as the rape of women.

In the annex to its final report, the CVES published a list of victims of sexual violence based on its compilation of testimonies. Where permitted, the Commission

---

<sup>48</sup> The Commission also relied on indirect sources of information from various international and domestic organizations, including the American Association for the Advancement of Science, Americas Watch, Amnesty International, the United Nations Working Group on Forced and Involuntary Disappearances, the *Comité de Familiares de Víctimas de las Violaciones de Derechos Humanos de El Salvador* "*Marianella Garcia Villas*, CODEFAM (Committee of Relatives of Victims of Human Rights Violations in El Salvador), the *Comisión de Derechos Humanos de El Salvador*, CDHES (Salvadoran Human Rights Commission), Tutela Legal, and Socorro Jurídico, the Salvadoran Armed Forces, and the FMLN (for a complete list see Appendix II, Commission on the Truth for El Salvador, 1993). The testimonies it received from other indirect sources covers 18,462 unique events of violence and 18,455 individual victims (CVES 1993, 23 and 45).

documented the individual's name, the date and location of the human rights violation, the type of violation, including rape, and the suspected perpetrator group. Of the 7,357 cases recorded, only 270 (3.7 percent) included rape (CVES Appendix II 1993, 8). Not all victims were identified by name, to protect their wishes for anonymity. Based on those who were, it again appears that the Truth Commission only identified cases of rape against women, and did not include sexual violence against men, such as sexual torture.<sup>49</sup> Moreover, the annex does not include demographic information on the victims, or contextual information on the crimes, such as how it unfolded, the sequencing of acts, who was present at the time, etc. Absent this data, it would be almost impossible to conduct a rigorous analysis on the motives of wartime sexual violence in El Salvador. Due to an agreement between the national government and the United Nations sealing the records of the CVES until 2042 (50 years after the completion of its work), it is not possible at this time to conduct an independent analysis of sexual violence using the commission's testimonies.<sup>50</sup> Instead, data will be used from two non-governmental human rights organizations – *Socorro Jurídico Cristiano* (SJC, Christian Legal Aid) and *Tutela Legal del Arzobispado* (The Archbishop's Legal Aid). The CVES used the original testimonies collected by both organizations to supplement its own documentation and analysis.

SJC was founded in 1975 as a nongovernmental human rights group to provide social and legal aid to those in need. After the 1979 coup, Socorro's work focused on providing assistance to victims of political violence and documenting those abuses. It

---

<sup>49</sup> There was one case of rape against an individual identified as male by his name.

<sup>50</sup> Access to documents of this nature, which include sensitive and private information on witnesses, victims and perpetrators of violent crimes, is often limited to protect those whose identity is contained within.

collected first-hand testimonies under oath from witnesses and victims of political violence, submitted habeas corpus petitions on all disappearances, and issued monthly statistical reports on the human rights situation in the country. After the murder of Archbishop Romero and the installation of Apostolic Administrator Arturo Rivera y Damas, disagreements emerged between the Archdiocese and SJC regarding the Archdiocese's suspicion of SJC's political bias and inattention to abuses perpetrated by the FMLN.<sup>51</sup> As a result, Tutela Legal was created in 1982 to replace SJC, which continued to operate and report on human rights issues outside the purview of the Archbishop's office.

Like its predecessor, Tutela Legal aimed to collect systematic information on the nature of violence and human rights abuses as a tool to wield pressure on those who were committing these abuses. Its methodology also mirrored that of SJC, but was expanded to include reporting on all abuses by all perpetrators where verification of the event was possible (Valencia-Weber and Weber 1986). It dispatched teams (comprised mostly of lawyers and university students) to suspected sites of violence, including state prisons and military bases. Its investigators collected oral testimony from witnesses and victims of violence and their loved ones. Individuals interested in speaking with a representative from Tutela Legal could visit the main office, located in the chancery offices of the Archdiocese of San Salvador, or visit their local Catholic church, which would coordinate contact with the nearest representative or regional branch of Tutela Legal (González 2009).

---

<sup>51</sup> The accusations of political bias against SJC were fair. As a matter of policy, Socorro did not report on abuses committed by the FMLN. However, subsequent investigations by independent nongovernmental organizations and the Truth Commission found that the FMLN was responsible for a small percentage (about 5 percent) of all human rights violations during the conflict.

Despite significant opposition from the Salvadoran and American governments, Tutela Legal was considered by most international experts to be one of few credible sources of evidence on human rights violations in El Salvador.<sup>52</sup> The UN relied on and cited data collected by Tutela in its repeated resolutions condemning the government's violation of international human rights and humanitarian law and its apparent unwillingness to investigate and prosecute offenses perpetrated by the armed forces.

In 1997, SJC and Tutela Legal gifted copies of the testimonies they collected to the University of Colorado, Boulder, which was to serve as a secondary depository and safe house for the organizations' records. The collection includes 64 boxes of case files on victims and survivors of political violence. Each file contains a standardized in-take form used by staff to record demographic information on the individual making the statement and the victim, and contextual information on the incident being reported, the alleged perpetrators involved and any measures taken by those involved to file a criminal charge or denunciation regarding the case (see Appendix B for examples of this form from SJC and Tutela Legal). Some files include additional information on the case, such as news reports, letters and petitions to the Supreme Court from the families of the victims, letters to state security agencies and the FMLN from Tutela Legal or SJC (acting on behalf of the victims and their loved ones) requesting information on the case, demanding the release of those captured, and/or demanding prosecution of those involved

---

<sup>52</sup> A prominent example of this disagreement is the case of the massacre of more than 500 civilians in El Mozote, Morazán. Even after mass graves of women, children and the elderly were discovered, the Salvadoran government, U.S. embassy and State Department contested reports by Tutela Legal describing the incident as a massacre, arguing instead that the deaths resulted from a battle between the state armed forces and rebels. The disagreement focuses on differing conceptions of "civilian" and "combatant" and how each is categorized under the concept of "victim." U.S. officials expressed particular concern over Tutela's treatment of civilian noncombatants who lived in close proximity to guerrilla camps (Valencia-Weber and Weber 1986). However, Article 13 of Protocol II of the Geneva Conventions clearly asserts that unless directly participating in hostilities, civilians cannot be attacked or targeted for violence (Geneva Conventions, Additional Protocol II, Article 13, 1949 <http://www1.umn.edu/humanrts/instree/y6pagc.htm>).

in human rights violations, as well as responses to those letters from state security and judicial institutions.

Because the work of Tutela Legal and Socorro Jurídico overlaps and is complimentary, I did not read all case files included in the collection. I excluded the testimonies collected by SJC after 1983. I read all of the testimonies collected by SJC between 1978 and 1983, and all of the testimonies collected by Tutela Legal. In total, this amounts to 60 boxes of records, and includes about 5,000 unique testimonies.

### **Potential Biases in the Data**

As described above, Tutela Legal and SJC relied on self-reported oral histories and testimonies to collect their data on political and sexual violence during the war. Data of this kind are often scrutinized to determine their veracity and potential biases. Individual testimony may be shaped by a number of factors, including one's memory, one's private interests or incentives, and the social, political and cultural context and dynamics at the time. When analyzing such data, social scientists must confront the relationship between testimony and "truth" and the silences and lapses present in personal narratives (Jelin 2003).

Tutela Legal and SJC collected denunciations of human rights violations *during* the conflict. Denunciations were typically filed within days of the event occurring. The case files of Tutela Legal and SJC read much like missing persons' reports. At the time the deponent files the report, s/he has incomplete information on the event. "*My wife never returned home from work.*" "*We were on our way to school when some guys with guns jumped out of a car and grabbed my friend.*" The victim may later be released from prison or be found dead. However, unless this updated information is transmitted to the

original reporting institution, the record of the event will remain incompletely coded as a kidnapping or arbitrary detention. As a result, particular *types* of violence – torture, sexual violence and extrajudicial execution – are probably underrepresented.

While this method of data collection minimizes the effects of memory formation processes or memory loss that is inherent in post-hoc investigations, it may also severely limit who is willing to speak openly and what they are willing to divulge about their experiences. Many may deem it too dangerous to travel to a regional human rights office or to be seen speaking with foreign investigators, journalists or human rights activists. Because of the fluidity of battle lines in civil wars and the targeting of those attempting to document and report on war-related events, researchers, investigators and journalists often find themselves at similar risk as the populations they are aiding.<sup>53</sup> Indicative of this climate of violence and fear, the armed forces required Tutela Legal’s investigators to sign waivers of responsibility for their physical safety while operating in contested regions of the country (González, 2009). As a result, both Tutela Legal and Socorro Jurídico often limited their investigations to urban areas where violence was less widespread. Neither organization, for example, reported on key massacres in rural areas in the early 1980’s because they were unable to obtain independent sworn testimony from eyewitnesses or individual victims at the time of their occurrence (González, Medrano and Rivera, 2009).<sup>54</sup> After the signing of the peace accords, Tutela Legal and the Truth Commission conducted in-depth forensic investigations, including the exhumation of

---

<sup>53</sup> The state carried out an explicit campaign of repression against journalists in El Salvador. The *Comité de Prensa de las Fuerzas Armadas de El Salvador*, COPREFA (Armed Forces Press Office) repeatedly threatened those who “distorted” the image of the Salvadoran state and government with “drastic measures.” Journalists’ names also figured prominently on death squad “hit lists” in the early 1980s (Valencia-Weber and Weber 1986).

<sup>54</sup> In some cases, this is not just the result of widespread violence in the area, but also because the totality of the massacres left behind no survivors or witnesses to relate their experiences.



mass graves, of well-known massacres in rural zones.<sup>55</sup> However, data from the contemporaneous case files of Tutela Legal and SJC should be considered as conservative estimations with particularly sparse coverage of rural zones that potentially underreport events in the most violent or contested regions.

In my analyses, I will take several precautions to address the potential biases of the original data. To compensate for the lack of testimonies on early episodes of mass violence in rural zones, I will supplement data from SJC and Tutela Legal with secondary sources and post-hoc and forensic investigations of well-known massacres.

## **Peru**

The Peruvian government established the *Comisión para la Verdad y Reconciliación*, CVR (Truth and Reconciliation Commission) on June 4, 2001 (Paniagua 2001). It was modeled, in part, on the commissions in Argentina, Chile, El Salvador, South Africa, and Guatemala, but commissioners also consulted with those working on the concurrent commissions in East Timor and Sierra Leone (Manrique and Sulmont 2007). The CVR learned from the successes and failures of these previous commissions, reflected in its decision to investigate a broad range of human rights violations and hold public hearings throughout the country.<sup>56</sup>

The CVR was charged with “clarifying the process and facts [of what] occurred, as well as the corresponding responsibilities, not only of those who executed them, but also

---

<sup>55</sup> See, for instance, Commission on the Truth for El Salvador 1993 and Tutela Legal 2008.

<sup>56</sup> The truth commissions in Argentina, Chile, and Uruguay have been criticized for restricting their investigations to deaths (either extrajudicial executions or torture that results in death) and forced disappearances, a choice which underestimates the level and potentially mischaracterizes the nature of violence. In Uruguay, for example, the truth commission did not investigate illegal detentions, which was later discovered to be the most frequently experienced human rights violation. Conversely, the significant role of public hearings in South Africa’s Truth and Reconciliation Commission led to their inclusion in the Peruvian model (a first for Latin American truth commissions). For a list of recent truth commissions and a critical overview of their structure and efficacy, see Hayner 2006.

who ordered or tolerated them, while at the same time proposing initiatives to strengthen peace and reconciliation among all Peruvians” (Toledo 2001, author translation). This included investigating assassinations and massacres, forced disappearances, torture, sexual violence, forced recruitment, violence against children, and violation of the collective rights of indigenous peoples. A notable distinction from the UN-sponsored truth commission in El Salvador, the CVR was created at the behest of the state government and comprised entirely of Peruvian citizens.<sup>57</sup> It had a staff of more than five hundred people, including twelve commissioners, and a budget of \$11 million.<sup>58</sup> Although sizeable and comparatively well financed, the CVR faced the challenge of documenting 20 years of the nation’s history and the most violent period since the Republic’s formation (Hayner 2006).

At regional offices throughout the country, members of the CVR team collected 16,917 testimonies from witnesses, victims, and perpetrators of violence and approximately 1,700 photographs documenting individuals’ varied experiences during the war.<sup>59</sup> It held public hearings where survivors were invited to denounce the violence

---

<sup>57</sup> It is unclear what, if any, effect the institutional origins of a truth commission have on the reporting of human rights violations. Arguably, state-mandated, financed, and controlled truth commissions are more partial in their reporting of abuses, and may be particularly disinclined to document state-perpetrated abuses, than those operated by independent and foreign entities. It appears unlikely, however, that this relationship would change the overall findings, that (1) the Salvadoran state perpetrated the vast majority of violent crimes during the civil war; (2) the Peruvian state perpetrated less than half of all human rights violations during the internal conflict; and (3) the Salvadoran state committed more abuses per capita than did the Peruvian state.

<sup>58</sup> Salomón Lerner Ferbres, former rector of *La Pontificia Universidad Católica del Perú* (Pontifical Catholic University of Peru) served as the Commission’s president. Beatriz Alva Hart, Rolando Ames Cobián, Monsignor José Antrín de Mayolo Larragán, Luis Alfonso Arias Graziani, Carlos Iván Degregori Caso, Gastón Garatea Yori, Humberto Lay Sun, Sofía Macher Batanero, Alberto Morote Sánchez, Monsignor Luis Bambarén Gaste Lumendi, and Javier Ciurlizza Contreras served as commissioners.

<sup>59</sup> The CVR opened twenty-six regional offices. Each department had at least one office; Apurímac and Cusco each had two. The number of testimonies collected in each department are as follows: 5,313 Ayacucho; 1,444 Apurímac; 1,154 Huancavelica; 316 Cusco; 2,441 Huánuco; 209 Ucayali; 735 San Martín; 579 Puno; 2,308 Junín-Pasco; 1,174 Lima-Callao; 1,295 Other; see CVR, *Informe Final*, 382.

they experienced. The hearings, which were broadcast on national television and radio stations, covered 318 cases and 422 testimonies.

Due largely to the advancements forged by the International Criminal Tribunals in the former Yugoslavia and Rwanda (established in 1993 and 1994, respectively), the CVR operated in a more gender-aware climate than the CVES in El Salvador and other similarly early truth commissions. At the urging of feminist scholars and activists in Peru, the CVR appointed a gender unit to investigate the varied roles and experiences of men and women during the civil conflict. They also lobbied to increase the overall gender consciousness within the Commission and in all of its work. While the unit's influence was limited, its work can be seen in the CVR's final report, which includes a historical analysis of gender inequality in Peruvian society, the role of women in civil society organizations and armed organizations, and the patterns of wartime sexual violence (Mantilla 2009).<sup>60</sup>

Each CVR case file includes several standardized in-take forms designed to capture data on the interview, deponent, and the victim(s) involved in the violent event (see Appendix C for examples of the forms used by the CVR). Accompanying these forms are summary narratives (*relatos*) of the individual's experiences during the civil war. Each *relato* follows the same format. Deponents begin by describing life before the event in question – what was life like in the community; was there a presence of the armed forces and/or Shining Path or MRTA; did they hear about, witness, or experience previous attacks or episodes of violence? These antecedent events frame the subsequent acts of violence. Next, deponents describe the violation(s) they wish to denounce to the

---

<sup>60</sup> In particular, the absence of a gender-sensitive approach within the national reparations program has been noted (Mantilla, author interview, 2009; Henríquez 2006).

CVR. These accounts may span up to 20 or more pages and include details on how exactly the events transpired. In subsequent sections of the testimony, deponents answer questions regarding the actions, if any, they took to report the attack, the effects of the violence on their daily lives, and their expectations from participating in the CVR. As another scholar noted:

The testimonies of the CVR provide an inexhaustible source of information. They describe the facts and narrate the experiences of the individuals and communities that were affected by the violence of those years. They tell us who were the victims and who the perpetrators and reconstruct their stories, opening up an invaluable and unimaginable opportunity to get closer to the lives and minds of the people who were directly or indirectly involved in and affected by the war.

(Portugal 2008, 14)

Using these records, I created a new dataset on political violence in Peru. The dataset builds directly on the work done by the CVR, adding greater detail to its database of violent events. Cases that were previously not included in the BDCVR, either because they fall within the 5,000 testimonies that were not coded for nonlethal violence or because the victims were not identified by name, were added.<sup>61</sup> Cases of sexual violence such as sexual torture that were overlooked or misrepresented in the CVR's work were also added. Reading almost 17,000 testimonies with great attention to detail and context would require far more time and resources than are available to the individual researcher. My database, therefore, is based on a sample of approximately 2,000 testimonies. I sampled randomly according to the event or case number (a number assigned at the time the case was entered into the BDCVR, but which is not correlated with the location or timing of the event), reading the testimonies for every tenth event. Since this includes

---

<sup>61</sup> The inclusion of unnamed or unidentified victims is of particular importance for cases of sexual violence. Victims will often actively deny that they themselves were raped, and instead report violence against "a friend," "a neighbor," or someone they know because it is easier to describe the intimate details of a sexual assault when it happened to a third person.

only those cases that were originally included in the BDCVR, I then oversampled from the range of cases that Commission staff did not code for nonlethal acts of violence.

The database is structured using the victim-violation-perpetrator as the unit of analysis.

### **Potential Biases in the Data**

Because of the retrospective nature of its investigations, information collected by the CVR through oral histories is subject to the ability of respondents to objectively and accurately remember past events. Memory recall, particularly of politically contentious events, is not an automatic, neutral or static process. Even with the purest intentions, survivors of violent traumas may be unable to precisely recount the details of an attack suffered up to 20 years ago. In conflict situations, where individuals often experience multiple traumas over the course of years, memories may merge, become muddled, or be lost altogether.

Research on memory formation and retention has produced disparate results. Some has shown that intense experiences and events, even political events, are remembered with greater accuracy over the short and long terms. Those suffering from Post-Traumatic Stress Disorder (PTSD), for instance, usually remember very well the details of past events (for more discussion on this, see Wood 2003, 33-35). Other studies have found no relationship between the intensity of the emotion evoked by a past experience and the accuracy of subsequent memories of the same experience (Neisser and Harsh 1992; Talarico and Rubin 2003). That said, most agree that while memory for details, particularly dates and precise locations, is more malleable, the narrative of “who did what

to whom” is stable over time and accurate.<sup>62</sup> This trend can be confirmed by comparing various testimonies of the same event that were collected independently by the CVR.

Individuals may remember differently the day, year, or village where a particular battle or attack occurred, but describe the event as it unfolded with remarkable detail and comparability.<sup>63</sup>

However well initially remembered, memories may be later reshaped by social, political, and cultural processes that affect which memories are unconsciously or selectively retained, privileged or forgotten. “What can change about the past is its *meaning*, which is subject to reinterpretations, anchored in intentions and expectations toward the future” (Jelin 2003, 26). This is of particular concern in conflict situations, where political alliances and opponents change continuously. Retrospective perceptions of events may be reframed or altered depending on how the conflict is resolved and who emerges the “victor.” In Peru, victims and witnesses to violence perpetrated by the *Sendero Luminoso - Partido Comunista del Peru*, SL-PCP (Shining Path-Peruvian Communist Party) often recounted the presence of and perpetration of specific violations by Edith Lagos Saez, a leader within the party, even after her death in 1982. As Gustavo Gorriti describes, “...there was something about her, perhaps her intensity, the imperious pride with which she carried her small figure...that marked her among her followers and

---

<sup>62</sup> A distinction should be made, however, between first and third person accounts. Individuals are more likely to correctly remember an event that they personally experienced or lived through than an event they heard or read about on the news. Testimonies from survivors and witnesses to violence are likely to be more credible than those from third parties or relatives who were not present during the attack.

<sup>63</sup> Kimberly Theidon’s research in Ayacucho (2007), Peru has raised the concern that conflict narratives may be predetermined by community leaders or established as a collective memory rather than individual accounts and experiences of violence. This could present a significant challenge to the data used here; however, further research is required to decide the validity of such claims. Because testimonies are given in private, there is no mechanism by which individuals could be held accountable for delivering the pre-rehearsed community narrative, even if previously pressured to do so by local authorities or elders. The risk of receiving a pre-rehearsed community narrative would be greater in group testimony settings.

contributed to the legend that would surround her...” (1999, 80). A remarkable figure at age 19, more than ten thousand people gathered at her funeral in Ayacucho city. The notable presence of armed female combatants in the ranks of the SL-PCP, and the particular mystique of Edith Lagos probably contributed to these erroneous reports.

I address the potential biases of the testimonial accounts of violence in Peru by drawing only careful and highly contextualized conclusions based on the primary data. Whenever possible, I supplement and compare findings from the data with other primary documents, such as government records, and secondary sources.

	<b>El Salvador</b>		<b>Peru</b>
	<b>CVES</b>	<b>Tutela Legal &amp; SJC</b>	<b>CVR</b>
<b>Timing</b>	Post-hoc, 9 months	Contemporaneous, duration of the civil war	Post-hoc, 25 months
<b>Mandate</b>	Investigate select crimes of a political nature between 1980-1991 Make binding recommendations to secure national peace and reconciliation	Document denunciations of human rights abuse	Investigate human rights abuses and violent attacks between 1980-2000
<b>Resources</b>	Entirely externally funded <sup>64</sup>	Predominantly internally funded	Predominantly internally funded
<b>Sponsor</b>	United Nations	Catholic Church	Peruvian Government
<b>Staff</b>	3 international commissioners, all men, appointed by Secretary General of UN	Between 12-25 local investigators, mostly lawyers and university students	12 Peruvian commissioners, 10 men and two women
<b>Report</b>	3 volumes, released March 15, 1993	None	10 volumes, released August 28, 2003
<b>Treatment of Sexual Violence</b>	None	No formal definition is provided, although documented cases span the full spectrum of sexual abuses	Sexual violence is defined broadly but investigation is limited to incidents of rape and gang rape
<b>Limitations of the Data</b>	Memory loss may limit/distort what individuals report Less accurate reporting of time and date when event occurred	Less complete coverage of violations that occur <i>after</i> initial capture	Memory loss may limit/distort what individuals report Less accurate reporting of time and date when event occurred

<sup>64</sup> A special \$2.5 million fund was administered by the UN. Funds were donated from willing members states, included the United States, the Netherlands, Norway and Sweden and other western European countries.

	Less accurate reporting of location where event occurred		Less accurate reporting of location where event occurred
<b>Strengths of the Data</b>	More complete oral histories of individuals' experiences during conflict	Very accurate reporting of time and date when event occurred Very accurate reporting of location where event occurred	More complete oral histories of individuals' experiences during conflict

**Table 3.1 Comparison of Human Rights Reporting Institutions in Peru and El Salvador**

### **Research Team and Inter-Coder Reliability**

The final data quality check I must address is the potential for bias to have been introduced through my reliance on a team of researchers to assist in reading and coding the testimonies. In this section, I briefly introduce each member of the research team and discuss the level of inter-coder reliability in the data on political and sexual violence.

In Peru, I hired four research assistants – three men and one woman between the ages of 22 and 30. They all lived in working and middle class neighborhoods in Lima. All four were seeking advanced university degrees in the areas of anthropology, history or law. Each was trained on ethical and technical aspects of the coding project and provided with a detailed codebook outlining the parameters and values of each variable in the database (see Appendix D for the codebook for the database on human rights violations and violent events in Peru and El Salvador).

In Colorado, I hired one assistant, a 63-year old retired archivist. She came from an upper-middle class family in Santiago, Chile. Her father was a General under the military regime of Augusto Pinochet. Despite the security that his position afforded the family, her parents decided to send her to France, where she lived until the end of the conflict. As an adult, she became a U.S. citizen and lived and worked as a librarian, archivist and researcher at various educational institutions in the U.S. I instructed her on the objectives of the investigation, the protocols for working with confidential and



personal information, and provided her with a book of coding rules (see Appendix D).

To ensure the reliability and accuracy of the data across members of the research team, all of the testimonies were independently read by at least two coders. Reliability refers to the likelihood that given a description of human rights abuse, each coder would describe the event similarly and would assign the same classifications to key variables. Accuracy, on the other hand, refers to the degree to which each coder correctly identified and recorded the details of human rights violations as they were reported in the testimony.

After one month of data collection, I personally reviewed the work of each coder to assess the data's reliability and accuracy. This revealed three areas of primary concern: the violation code, the total number of victims involved in the case, and the identification of unnamed victims. Errors in coding human rights abuses were confined to a few distinct violation types – (a) kidnappings by non-state armed actors or extrajudicial detentions by state security officers that occurred outside of sanctioned detention facilities, both coded as “LSE;” (b) detentions by state security officers that occurred in sanctioned detention facilities, coded as “LDT;” (c) extrajudicial executions by either state or non-state armed actors, coded as “MAE;” (d) deaths caused by one-sided attacks with explosives by non-state armed actors, coded as “MAT;” and (e) deaths as the result of battle or combat between two armed groups, coded as “MEF.”

That these codes resulted in the most disagreement and inconsistency is not surprising since they essentially address the same types of human rights abuse. The “LSE” and “LDT” codes both refer to an individual being captured and held against their will; the only difference is the *context* in which the crime occurred and the specific

*location* where the person was held. Similarly, cases where the victim dies could be coded as either “MAE,” “MAT,” or “MEF” depending on *how* the person was killed. To address these coding errors, the violation type “MAT” was dropped. Deaths from explosive attacks by the Shining Path or the MRTA were included under the code “MAE,” but can be distinguished from other types of extrajudicial executions by the “weapon type” variable code. Also, I spent additional time with each member of the coding team to identify and reinforce the distinguishing characteristics of each violation. After this intervention, coding of the violation type became more consistent and accurate.

The last two coding errors – the total number of victims and the number of unnamed victims involved in the violent event – are related. In this case, errors were not the result of ambiguity or confusion in the definition of the variable, but rather resulted from the different abilities of each researcher to see the fine details in the narrative. When reading a testimony, sometimes 20 to 50 pages long, of complex events, such as the massacre of an entire village, it is difficult to correctly identify and recall all of the victims, including those for whom the deponent did not know the name, but may have reported as “my neighbor’s daughter” or “the man from the coop.” To address this, I read every case summary as reported by the research team and personally verified the values of these two variables. Additionally, all descriptive statistics are reported and models run including and excluding unnamed victims.

### **Introducing a New Database on Political and Sexual Violence in Peru and El Salvador**

Each testimony within the sample was read and information on the identity of the victims, alleged perpetrators, and the type of violation was recorded. I included

information on cases of detention, disappearance, extrajudicial execution, death as a result of armed combat, injury, forced recruitment, kidnapping, torture, and multiple forms of sexual violence, including rape and gang rape, sexual torture, sexual mutilation, sexual humiliation, sexual coercion, forced abortion, forced impregnation, sexual slavery and a general category for unspecified forms of sexual violence. Additional details, such as descriptions of preceding events and the context in which the violence was perpetrated, were recorded for each case. I paid particular attention to such key facts as how the victim came to be targeted for violence, what he or she was doing at the time of the attack, who was present during the commission of the violence, and exactly where the violence was perpetrated. I documented whether the victim or his or her family or friends were previously targeted for violence. I also recorded language used by the perpetrators during the assault. Evidence of sexist or racist language can be particularly useful for inferring motive or demonstrating small-group norms regarding the use of violence.

### **Conclusion**

There are a number of methodological obstacles researchers confront when analyzing political violence. Accurately capturing the historical record is no small feat. When focusing on sexual violence in conflict situations, the obstacles become more frequent and complex. Underreporting is so pervasive that statically estimating the total number of victims is likely impossible. As victims themselves are reluctant to report sexual abuse, we must be particularly careful to not “lose” their stories when recording, coding, or manipulating the data.

In this chapter, I discussed three methodological decisions that researchers must make when collecting and reporting statistics on the occurrence of sexual violence.

These include (1) how to define and measure sexual violence, (2) whether to include only named or both named and unnamed victims of sexual violence, and (3) how to treat ambiguous language in victims' statements. Above, I argue for a broad definition of sexual violence, the disaggregated coding of all forms of sexual violence, the inclusion of unnamed victims, and special attention to be paid to the linguistic nuances in reporting sexual violence. Implementing this research strategy, I find that sexual violence was more prevalent during the Peruvian civil war than previously reported by the CVR. I find that during the civil wars in Peru and El Salvador men were more often the victims of sexual abuse, particularly sexual humiliation and torture, than previously thought. The following chapters examine in greater detail these and other patterns to determine the motivation of wartime sexual violence in Peru and El Salvador.

**PART I:**  
**WARTIME SEXUAL VIOLENCE IN PERU, 1980-2000**

## CHAPTER 4

### MANCHAY TIEMPO (TIME OF FEAR): THE PERUVIAN CIVIL WAR, 1980-2000<sup>65</sup>

*One of the most characteristic features of the country is its weak national integration, as seen in the large fragmentation of its regional areas and the absence of full acknowledgment of the ethnic diversity of its inhabitants.*

(author translation CVR 2003, 57)

#### **Introduction**

Roughly the size of California, Peru is divided into three sharply distinct ecological-geographic regions: (1) the mostly arid coastal lands along the Pacific ocean, (2) the mountainous central sierra with deep river valleys and mountain peaks reaching over 20,000 feet, and (3) the dense forces of the eastern Amazon region. Coupled with the topography of the country, the almost complete absence of the central government in the countryside led to the isolation and neglect of rural communities. For many peasants, the first and only contact they had with the state was during the completion of their compulsory military service.

With a growth rate of almost 10 percent annually, Peru has one of the fastest growing economies in the world today. Yet, more than half of its population lives below the national poverty line. Once the political and economic seat of the Incan empire, Peru's cultural heritage and ethnic diversity attract approximately 1.5 million people from around the world every year (WTO data). Forty-five percent of its 30 million people are members of one of Peru's nearly two dozen native communities.<sup>66</sup> The largest of these are Quechua, Aymara and Asháninka Indians. Despite the celebration and marketing of

---

<sup>65</sup> For a history of pre-war Peru, see Starn, et al. 2005.

<sup>66</sup> Others estimate persons of indigenous descent to comprise about one-third of the total population of Peru (CVR 2003).

its multiculturalism (primarily for foreign consumption), Peru remains a deeply divided society that continues to economically and politically marginalize its native compatriots (see Table 4.1 for an overview of Peru in figures). Unsurprisingly, during periods of domestic upheaval and economic depression, scapegoating and virulent hateful rhetoric are not uncommon:

Peru owes its misfortunes to the indigenous race, whose psychic degeneration has taken on the biological rigidity of a being that has definitively stopped evolving, and which has failed to contribute to the mestizo the virtues of a progressive race....The Indian is not, and cannot be, anything but a machine”

(qtd in Stern, et al. 1995, 269)

More than anything else, Peru is a divided country – politically, economically, racially and even geographically. Discord with an exclusionary political system and economic marginalization helped to give rise to the *Partido Comunista del Perú – Sendero Luminoso* (PCP-SL, Communist Party of Peru – for the Shining Path of Mariátegui) and *Movimiento Revolucionario Túpac Amaru* (MRTA, Tupac Amaru Revolutionary Movement) and launched the most violent conflict in the Republic’s history (see Table 4.2 for a summary).<sup>67</sup>

Awareness of the cultural, economic and political divisions in Peruvian society goes a long way to understanding the underlying causes of the civil war, the nature of the dual insurgencies, as well as the shortcomings of the state’s counterinsurgency strategy.

This Chapter provides a historical analysis of the Peruvian civil war from 1980 to 2000, the most violent and lethal period in the nation’s post-independence history. It begins with an overview of the origins and evolution of the Shining Path (and to a lesser

---

<sup>67</sup> Throughout the text, the PCP-SL and Shining Path will be used interchangeably. “*Sendero*” is used to describes activities or thoughts of the organization and “*Senderistas*” is used to refer to members of the Shining Path.

extent the MRTA). Next, it discusses the military's training practices and national security doctrines that informed the state's response to the insurgency. It then examines in closer detail the evolution of the state's counterinsurgency strategy across the administrations of Presidents Fernando Belaúnde Terry (1980-1985), Alan García (1985-1990) and Alberto Ken'ya Fujimori (1990-2000). For each, one emblematic human rights case or military operation is presented to illustrate the security doctrine and strategies in place at the time.

First a note about the evidentiary materials used in this chapter. Data used in this chapter come from secondary sources, interviews, but mainly from declassified documents from the Peruvian military archive and the National Security Archive in the Washington, DC. Regarding the appropriate use of such materials, the National Security Archive states:

...while declassified documents represent an important piece of the historical puzzle, one must always take into account the context in which they were created. The assessment begins by considering the source and type of information contained in each document. Some documents contain raw information, which repeats verbatim views and statements made by other officials, journalists, activists, etc., as told to or gathered by the government worker producing the document. In these cases, one must evaluate the relative validity of the original source of information. For example, in a US embassy cable that recounts a conversation with a disgruntled Peruvian military officer, one must balance the information this source reveals with the officer's personal motivations for sharing the information with the embassy, as well as his political and ideological leanings in order to evaluate its veracity. Often, such cables will contain a comments section that reveals details and embassy evaluations of the sources of information. Similarly, when evaluating documents that contain more finished intelligence or government reports, one must also consider the personal motivations, political beliefs and professional goals of the document's author.

(NSA, "Peru: Human Rights, Drugs and Democracy, 1980-2000)



The point that the investigator must consider the original source of the material, the potential motivations for creating and disseminating it, is astute advice and relevant not just to declassified documents from their own collection, but equally important in the use of secondary sources and interview materials.

Surface Area (km <sup>2</sup> )	1,285,220		
Population	29,164,883		
Population Growth (annual %)	1.13		
Major Indigenous Ethno-Linguistic Groups	<b>Quechua</b> ≈ 3.3 million Ancash, Cajamarca, Cusco, Ayacucho, Huanavelica	<b>Aymara</b> ≈ 450,000 Puno	<b>Asháninka</b> ≈ 25,000-45,000 Junín, Huánuco, Pasco, Ucayali
<b>Development Indicators</b>			
Infant Mortality Rate (per 1,000 live births)	19.4		
GDP (current USD, in billions)	\$130.3		
GDP Growth (annual %)	8.5		
GDPpc (constant 2000 USD)	\$2913.01		
<b>Status of Women Indicators</b>			
Fertility Rate (total births/woman, 2008)	2.5		
Women in Parliament (%)	27.5		
Primary School Enrollment (ratio of female to male, 2002)	99.5		
Secondary School Enrollment (ratio of female to male, 2002)	93.1		
Tertiary School Enrollment (ratio of female to male, 2002)	107.2		
Literacy (ratio of female to male, ages 15-24, 2004)	97.8		
Gender Empowerment Measure (rank out of 109 countries)	36		

**Table 4.1 Peru in Figures: Evidence of a Divided Society**

### **The Emergence of the Shining Path and the “People’s War”**

The twenty-year war began with a single act of sabotage. On May 17, 1980, a small group of armed persons broke into the local election board offices in Chuschi, Ayacucho<sup>68</sup> and burned the ballot boxes to be used the following day in the country’s

<sup>68</sup> Before earning the distinction of being the birthplace of the Shining Path, Ayacucho (a department in the central sierra) was most notable for its “confluence of an extremely impoverished indigenous peasantry in the countryside and a politically effervescent university culture in the region’s small capital city” (Stern 1998, 1).

first democratic elections in twelve years.<sup>69</sup> With this, the Shining Path insurgent organization declared war against the Peruvian state and began the most violent period of conflict in the country's history.

<b>Major Rebel Groups</b>	<p><i>Partido Comunista del Perú – Sendero Luminoso (PCP-SL, Communist Party of Peru – for the Shining Path of Mariátegui)</i></p> <ul style="list-style-type: none"> <li>• Marxist-Leninist-Maoist</li> <li>• Highly centralized, led by Central Committee with Abimael Guzmán as supreme leader</li> <li>• Based in Ayacucho &amp; Upper Huallaga River Valley</li> <li>• Est. 5,000 cadre, 50,000+ supporters</li> </ul>
	<p><i>Movimiento Revolucionario Túpac Amaru (MRTA, Tupac Amaru Revolutionary Movement)</i><sup>70</sup></p> <ul style="list-style-type: none"> <li>• Marxist-Leninist</li> <li>• National executive committee led by Victor Polay, Nester Cerpa &amp; Alberto Galvez</li> <li>• Based in Lima</li> <li>• Est. 1,500-2,000 cadre</li> </ul>
<b>Most Salient Cleavage of Organization and Contention</b>	Economic class <sup>71</sup>
<b>Armed Forces Personnel (average for conflict period)</b> <sup>72</sup>	152,707
<b>Military Expenditure (% of central govt spending, average for conflict period)</b> <sup>73</sup>	9.3

<sup>69</sup> However flawed the democratic system may have been, between 1980 and 1992 the country held free local and national elections and enjoyed freedom of the press (see Table 4.3 at the end of the chapter for a list of governments and regimes in Peru from 1962 to 2011). The Shining Path never intended to inject itself into the existing political system, but rather to destroy it and create a new government in which Abimael Guzmán would exercise supreme authority.

<sup>70</sup> The MRTA's namesake, Túpac Amaru was the last indigenous leader of the Incan empire. In addition to the MRTA, his image and name was appropriated by the Indian rebellion for independence from the Spanish colonial empire, led by José Gabriel Condorcanqui-Túpac Amaru in the 1700s. The rebellion was successfully put down and Spain continued to rule until 1821.

<sup>71</sup> While the Shining Path made a few appeals to "Indian pride" in an attempt to galvanize the support of local peasants, theirs' was not an ethnic conflict fought to restore a marginalized group to power or to protect an "Indian way of life." In this sense, the Peruvian civil war was less an ethnic war than it was a class-based conflict.

<sup>72</sup> Data are from the World Bank Databank and includes all active duty military personnel [http://databank.worldbank.org/ddp/editReport?REQUEST\\_SOURCE=search&CNO=2&country=NPL&series=&period=](http://databank.worldbank.org/ddp/editReport?REQUEST_SOURCE=search&CNO=2&country=NPL&series=&period=) (last accessed 02.22.11). Complete definitions, measurements and data sources can be found in the World Bank Databank's Indicators webpage at <http://data.worldbank.org/indicator>.

<sup>73</sup> Data on military spending are from the World Bank Databank and includes all expenditures on the armed forces, defense ministry, and other government agencies involved in defense projects [http://databank.worldbank.org/ddp/editReport?REQUEST\\_SOURCE=search&CNO=2&country=NPL&series=&period=](http://databank.worldbank.org/ddp/editReport?REQUEST_SOURCE=search&CNO=2&country=NPL&series=&period=) (last accessed 02.22.11). Complete definitions, measurements and data sources can be found in the World Bank Databank's Indicators webpage at <http://data.worldbank.org/indicator>.

<b>Military Expenditure (% of GDP, average for conflict period)</b>	1.4
<b>Battle-Related Deaths (total)<sup>74</sup></b>	18,678
<b>Other Deaths and Disappearances<sup>75</sup></b>	69,280

**Table 4.2 The Peruvian Civil War: Key Facts and Figures**

The Shining Path combined the politico-military ideology of Mao Zedong and the Chinese Communist Party with the teachings of Abimael Guzmán,<sup>76</sup> a philosophy professor at the *Universidad Nacional de San Cristóbal de Huamanga* (San Cristobal National University of Huamanga) in Ayacucho. They called for immediate action to overthrow the existing imperialist system of power and realize the “people’s revolution.” Choosing with intention and deliberation a time and symbol of democratic rule, it is clear that the Shining Path never wanted to inject itself into existing power structures, but rather to destroy them and create a new political system, in which Guzmán would exercise supreme authority. The SL sought to “bring about the generalization of political violence, the gradual encirclement of the cities, the eventual collapse of the government, and the establishment of ‘New Democracy’” (Marks and Palmer 2005, 98).

Guzmán viewed himself as the “Fourth Sword of Marxism.” He believed that the Communist revolutions in China and Russia had become revisionist dictatorships and that it was up to the Shining Path to carry out the people’s war according to the *true* ideological principles of Marx, Lenin and Mao (Marks and Palmer 2005). As such, the Shining Path had only limited ties with foreign revolutionary powers and relied principally on internal resources (extortion, theft and drug trafficking among them) to

<sup>74</sup> According to the Uppsala Conflict Data Program, battle-related deaths “typically...occur in what can be described as ‘normal’ warfare involving the armed forces of the warring parties. This includes traditional battlefield fighting, guerrilla activities (e.g. hit-and-run attacks/ambushes) and all kinds of bombardments of military units, cities and villages” (Uppsala Conflict Data Program 2011).

<sup>75</sup> According to Multiple Systems Estimation (MSE), 69,280 people were killed or disappeared during the Peruvian civil war. With a 95 percent confidence interval, this could range between 61,007 and 77,552 (Ball, et al. 2003).

<sup>76</sup> Guzmán’s legal name is Manuel Rubén Abimael Guzmán Reynoso, but is more commonly known by Abimael Guzmán or his nom de guerre Presidente Gonzalo.

finance their operations.

The Shining Path was a heterogeneous organization, whose members varied in their socio-economic backgrounds as well as motivations for membership. The popular base of the SL was comprised of peasants and merchants, and what González-Castañeda refers to as the “depeasantized peasants, the educated young sons and daughters of peasants who rejected the backward cultural traditions of their parents and were disenchanted with the meager opportunities society offered them for the realization of their social aspirations” (2006, 50). University students were second-rank militants; they often had prior experience in social or political movements and were ideologically committed to the organization. Teachers and local officials were also strongly motivated by the SL’s ideology and dedicated to the “popular war,” but filled top ranking positions in the party (Portugal 2008, 1). The “Sacred Families” – the Morotes, Casanovas, Carhuas, and Durands – were provincial elites from Ayacucho linked by intermarriage and political conviction. These families formed the nucleus of the SL and the Central Committee. At the center of this leadership was Guzmán himself, an intellectual, born to a middle class from Mollendo, Arequipa (Starn 1995, 404).<sup>77</sup>

Centered around a personality cult to Abimael Guzmán, the Shining Path required total devotion of its members to their leader. Below is an excerpt of a letter written by an anonymous militant to the Central Committee of the Communist Party of Peru, which reflects the submission of individual will to the group:

---

<sup>77</sup> Henríquez (2006) makes similar distinctions amongst the women militants of the Shining Path: “at the top were the cadres committed to the ideological proposition and popular war, with an adherence to the party and to the leader that was not questioned; below were the emerging cadres, second-rank militants with ideological preparation that combined social sensitivity with personal experiences of exclusion and injustice; following them were the sympathizers with less political conviction and understanding of the war, who saw in the PCP-SL an opportunity for change, a channel to alternative forms of power; then there were those who were forcibly recruited...” (21, author translation).

Dear Comrades: I give you my greeting and my full and unconditional submission to the greatest living Marxist-Leninist-Maoist on earth: our beloved and respected President Gonzalo, chief and guide of the Peruvian revolution and the world proletarian revolution, teacher of Communists and party unifier. I give you my greeting and full and unconditional submission to the scientific ideology of the proletariat: Marxist-Leninist-Maoist and Gonzalo Thought, especially Gonzalo, all-powerful and infallible ideology that illuminates our path and arms our minds. I give you my greeting and full and unconditional subjection to the great, glorious, correct, and victorious Communist Party of Peru: the great instrument of the armed revolution...  
(qtd in Starn, et al. 1995, 350).

Unlike other leftist rebel groups in Latin America, the Shining Path did not accept violence as simply necessary, but celebrated its use. In fact, they glorified the human costs of war in their revolutionary poems and songs:

La sangre del pueblo tiene rico perfume  
Huele a jasmínes, violetas, geranios y margaritas  
A pólvora y dinamita  
¡Carajo!  
A pólvora y dinamita.

The blood of the people has a rich perfume  
It smells of jasmine, violets, geraniums and daisies  
Of gunpowder and dynamite  
God damn it!  
Of gunpowder and dynamite.

(Kirk 1997, 179, translation in original)

Amongst the *Senderistas*, there was talk of a “quota.” Members were expected to embrace the risk of death. As one militant wrote, “blood makes us stronger...and if it is flowing, it is not harming us, but giving us strength” (qtd in Gorriti 1995, 316). As leader of the Shining Path, Guzmán rejected any notion of an ideology of human rights, saying:

[f]or us, human rights contradict the rights of the people because we base ourselves in man as a social product, not in an abstract man with innate rights. ‘Human rights’ are nothing more than the rights of the bourgeois man...  
(qtd in Stern 1998, 431)

Totalitarian in nature, the group’s dogmatic ideology (based on the *pensamiento*

*Gonzalo*) believed anyone who was not an active cadre as an enemy of the revolution; “[t]hose who were with the party could do anything, and those who were against the party had no rights” (CVR 2003, 259 author translation).<sup>78</sup> The Shining Path viewed paternalistically the local population, and treated with contempt those who foolishly refused to aid in their own “liberation.” Those who represented the “old order” – governors, justices of the peace and anyone who continued to participate in activities that were part of the “old way of life” were subject to abuse. According to testimonies of local villagers, community life was completely disrupted after the arrival of the Shining Path; “[t]he normal activities in the community, such as the markets, customary festivals and religious masses disappeared” (CVR Testimony 301686, author translation). Where they existed, the Shining Path dismantled bridges, local cooperatives and irrigation systems. As a result, many of the local authorities and community leaders renounced their positions or fled the area, creating the intended power vacuum that would allow the SL to establish control.

The violent manifestation of this exclusionary ideology is recounted in the testimonies of witnesses of the Shining Path’s *juicios populares* (people’s trials or popular judgment) (see CVR Testimonies 400147, 500605, 487506, 304534, 437681 and 301685). In one such case, a group of *Senderistas* entered a small village in Junín and gathered all the members of the community together in the plaza for a meeting. Two villagers, Celestino and Raúl, were brought before the community, accused of being *cabezas negras* (traitors to the revolution). Every member of the community was asked about their knowledge, confidence and respect for the two accused. In the end, the

---

<sup>78</sup> For this reason, the Shining Path has been compared to Pol Pot’s Khmer Rouge in Cambodia (Basombrío 2001).

villagers' pleas were irrelevant; the *Senderistas* were convinced of the men's guilt. In a display of ultimate power and control, both men were shot and killed in front of the community (CVR Testimony 301686).

Also among those targeted for Sendero repression were members of moderate leftist organizations and political parties in Peru, human rights and community leaders, and even other armed rebel groups, such as the MRTA (see Figure 4.1).<sup>79</sup> One of the most well known cases of SL violence, the assassination of María Elena Moyano, has become a symbol of the group's brutality and totalitarian orientation. Before her death, María Elena was a member of *Izquierda Unida* (IU, United Left political party) and served as vice mayor of Villa El Salvador, a shantytown in southern Lima.<sup>80</sup>

---

<sup>79</sup> The MRTA initiated its armed struggle against the state in 1984. A militarily weaker and less violent rebel army, the MRTA was responsible for less than 2 percent of human rights violations documented by the CVR. In its most famous act of violence, insurgents stormed the Japanese Embassy and held dozens of people hostage for months. Conversely, the strength of an organization that is able to overtake a protected government building, hold hostage 72 persons, including such political dignitaries as the President's brother, at least 15 ambassadors, the top leadership of the military, and members of Congress, for months, should not be minimized (see Burt 2008 or Jara 2007 for an analysis of this event). In April 1997, the armed forces took back the Japanese Embassy by force. *Operación Chavín de Huántar* (Operation Chavín de Huántar) has been called the most "outstanding" military operation during the civil war (Ministerio de Defensa 1995).

<sup>80</sup> Until 1971, Villa El Salvador was uninhabited desert land. Migrants from run-down neighborhoods in central Lima organized and began to occupy the land in the 1990s.



**Figure 4.1 Villa El Salvador, 2010 (author photograph)**

She was an active community organizer; she helped to found the *Federación Popular de Mujeres de Villa El Salvador* (FEPOMUVES, Popular Federation of Women in Villa El Salvador) and spearheaded the building of local community kitchens and “Glass of Milk” programs. It was her outspoken criticism of and opposition to the Shining Path that ultimately led to her death.

On February 14, 1992, in defiance of a nation-wide armed strike called by the Shining Path, Moyano led a March for Peace through the streets of Lima. The next day, she was brutally murdered at a community fundraiser. With a crowd of onlookers, including her two young children, an SL assassination squad shot her in the head and then blew up her body with dynamite (Burt 2010). Her death, while highly publicized, is just one in a constellation of Sendero violence against the left in Peru (Feinstein 2011).



## Selected political assassinations and attacks

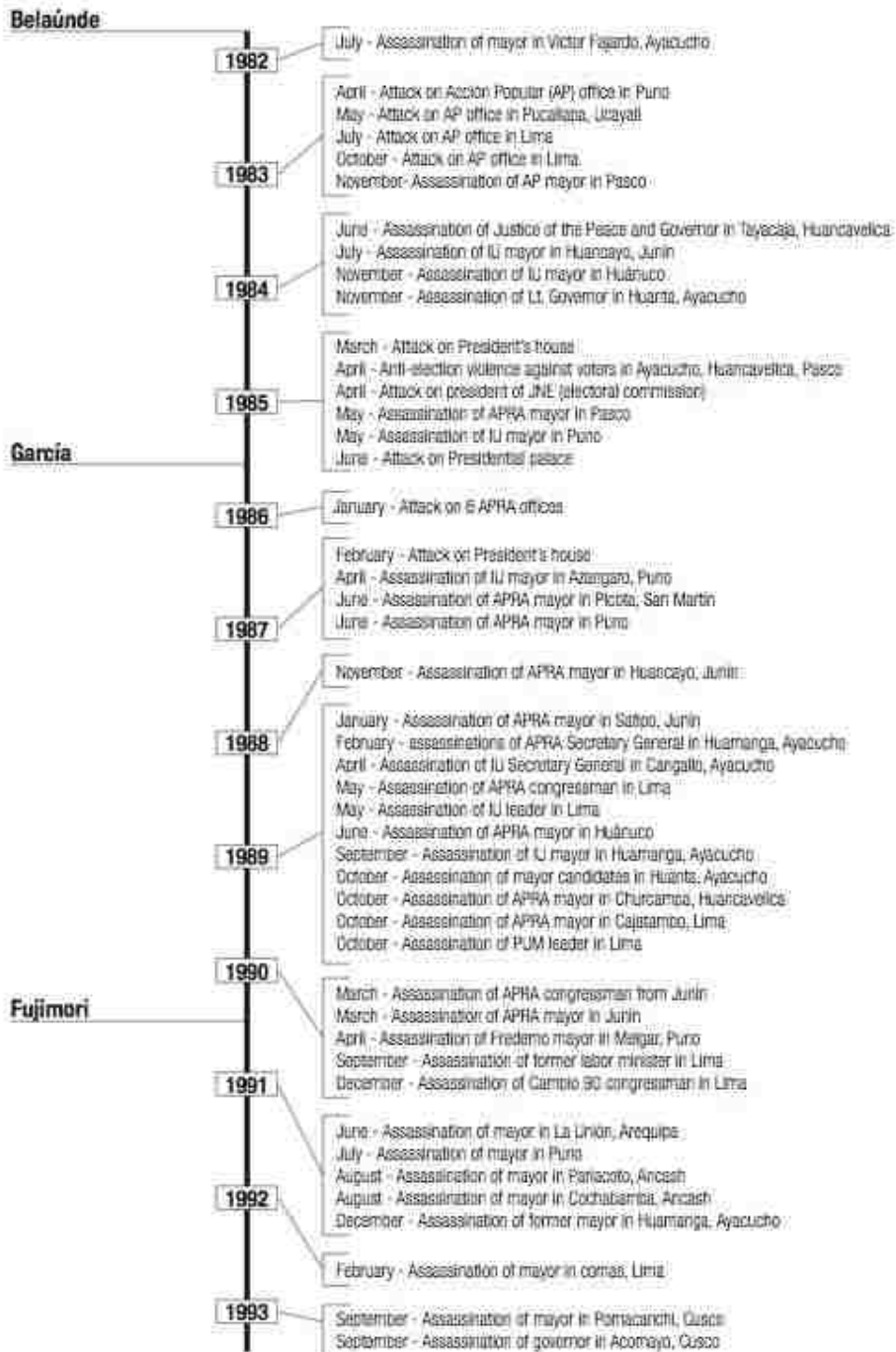

Figure 4.2 Shining Path Attacks and Political Assassinations

Sendero repression against the civilian population peaked around 1990, when the

Shining Path declared “strategic equilibrium” in its war against the state. During this time, the group’s demands on the civilian population increased – forced recruitment of the youth, demands for food and money, and expectations of participation in the *masas* increased. Discipline and control mounted; those who disobeyed were summarily executed (Degregori and Rivera 1993, 13).

In addition to direct repression, the Shining Path’s warfare strategy included high-visibility attacks and psychological operations designed to reveal the state’s incapacity. This might include the transmission of SL propaganda through television and radio broadcasts, replacing prominently displayed flags of the Republic of Peru with that of the Shining Path, and blanketing communities with the paintings and images of the revolutionary movement. Likewise, bands of armed cadre would attack strategic sites, such as electrical towers, hydroelectric dams, radio stations or water processing plants that provided services to urban centers, including the capital. At the same time, the Shining Path would increase its own military capabilities and augment its weapons supply by attacking isolated military bases, police stations and poorly secured mines (where there was sure to be a supply of explosive materials).

The following sections consider the national security doctrine and ideology of the armed forces that informed the state’s response to the Shining Path. Who were the opponents? How were they described?

Although the military would not be called into action until two years after the beginning of the civil war, they are, in particular the Army, the main actors in the fight against internal subversion and terrorism. Therefore, this section will consider the general security doctrines and training of the military before discussing in greater detail

the varied responses of each presidential administration to the national security threat.

### **The State Response: National Security and Counterinsurgency**

We promise to maintain a national security policy that guarantees [Peruvian] independence, sovereignty, territorial integrity, and safeguards [our] national interests. We believe this is a task that involves society as a whole, the agencies of the State, especially the Armed Forces, in accordance with the Constitution and law. In this way, we promise to prevent and face any external or internal threat that puts in dangers the social peace, fundamental security and general wellbeing [of the country]. (author translation, Ministry of Defense 1995, 64)

The above quote comes from the Ministry of Defense's *Libro Blanco de la Defensa Nacional* (White Book of National Defense, hereafter referred to as the 'White Book') and reflects the most basic tenets and objectives of the armed forces in providing for the security of the Peruvian state. Much has been made of the developmentalist/populist tendencies of the Peruvian military and its national security doctrine (as reflected in the above statement). Historically, military leaders have placed significant emphasis on addressing the underlying structural inequalities and contradictions in society as a necessary component to protecting the state's security. The *Centros Altos Estudios Militares* (CAEM, Center for Advanced Military Studies) in Peru emphasizes a generalized well-being, in which "the material and spiritual needs of the person are satisfied in a timely and sufficient manner..." (author translation, CAES 1987, 15).

Indeed, in the twenty years preceding the outbreak of civil conflict, it was the military that spearheaded many of the most substantive socio-economic reforms in the country's history. In this regard, the military regime of 1968-1980 in Peru is notably distinct from that in Argentina (1976-1983), Brazil (1964-1986) and Chile (1973-1990).

On October 3, 1968, the military overthrew Belaúnde not to preserve the oligarchical order of the "forty families," but to carry out economic and political reform.

Within its first year of business, the Revolutionary Government of the Armed Forces, led by General Juan Velasco Alvarado, selectively nationalized foreign extraction enterprises, encouraged the mobilization and corporatist organization of the peasant class through participation in agricultural cooperatives and the newly created National System of Social Mobilization (SINAMOS), and promulgated one of the most expansive agrarian reform and land redistribution programs in modern Latin American history.<sup>81</sup>

Unlike other Latin American military leaders, General Juan Velasco who once described his childhood as one of “dignified poverty,” saw himself as a defender of the poor (Masterson 1991). On June 24, 1969, Velasco introduced his reform agenda in a televised national address. This speech is quoted at length for its illustration of the reformist and developmentalist tones of the Peruvian military under General Velasco:

Peruvians: This is a historic day. And it’s important that we all be aware of its full significance. Today, the Revolutionary Government has issued the Agrarian Reform Law...History will remember this June 24 as the beginning of an irreversible process that will lay the groundwork for true national greatness, founded on social justice and the real participation of the people in the wealth and future of our motherland. Today, ...the Revolutionary Government honors [the peasant] with the best of tributes by giving to the nation a law that will end forever the unjust social order that impoverished and oppressed the millions of landless peasants who have always been forced to work the land for others....From this day forward, the Peruvian peasant will no longer be a pariah or disinherited and living in poverty from the cradle to the grave, powerless to make a better future for his children. As of this lucky June 24, Peruvian peasants will truly be free citizens whose motherland has finally recognized their right to the fruits of the land they work...

Speaking of the role of the armed forces in social reform and national politics, he goes on:

---

<sup>81</sup> Many of the initiatives and programs created by Velasco’s government were dismantled by the counter-reforms of the second military government (that deposed Velasco in 1975). Those that remained were not without their negative consequences. The Revolutionary Government’s massive public works projects required significant foreign borrowing and set the stage for the economic instability and hyperinflation of the 1980s. The government passed legislation limiting workers’ rights to mobilize independently from state-sponsored labor organizations and fired more than 5,000 public-sector employees (Burt 2006).

...the country's transformation is the historic mission of the Armed Forces Government....the work of government was never understood by the armed forces to be the banal exercise of power, without direction or purpose; nor was it ever understood, under this regime, as a way to maintain the basic and unjust social order...we assumed political power to make the state into a productive instrument for the transformation of the motherland.

He concludes his speech, invoking the historic revolutionary spirit of Tupac Amaru:

Today, the Revolutionary Government feels the deep emotion of a mission and a duty fulfilled. Today, on the Day of the Peasant, we look to the citizenry with faith, pride, and hope; and we say to all of Peru that we owe the inspiration of our acts to the people and to them we today deliver a law that will forge greatness and justice as its destiny. To the men of the land, we can now say in the immortal and liberating voice of Túpac Amaru: Peasant: the Master will no longer fee off your poverty!

(Velasco 1969, 279-284)

Hints of this institutional legacy can be seen in most early efforts of the police and armed forces to win the "hearts and minds" of local populations in the emergency zones. Understanding that such alliances would prove crucial in the identification, capture and eventual defeat of the subversives, the Belaúnde and García administrations established programs to distribute food, medical supplies and clothing as well as provide interest-free credit to rural peasant communities, many of which were amongst the poorest in the country. However, there was never a serious committed effort on the part of either government to carry out widespread structural reforms in the Andean countryside. Any populist interventions aimed at undercutting popular support for the insurgents were short lived and inadequate.

Moreover, a distinction must be made between the military's national security doctrine and its counterinsurgency doctrine. Here, the stark contrast to the military practices and policies of its neighbors in the region begins to fade. According to the CAEM:

...when a Peruvian soldier says they are going to focus on the subversive threat, that they are going to engage in counter-subversion, the only thing they understand is that they have to put on their helmet, their bullet-proof vests, and shoot. So once he puts on his helmet, he is the same as the Argentine soldier, the Chilean, Uruguayan, Brazilian or Colombian soldier; he shoots to kill and exterminate....The counterinsurgent combatant cannot ignore the modus operandi of the Marxist-Leninist guerrilla and has to be prepared to confront it and destroy it....The special training of the counterinsurgent should be geared towards the real war conditions that the counterinsurgent combatant will engage and operate in. In this way, ...the counterinsurgent should use all of the same dirty weapons as the insurgent, and if the insurgent tricks, the counterinsurgent should trick too, if the insurgent murders, the counterinsurgent should murder, if the insurgent uses venomous spiders, the counterinsurgent should use venomous spiders too.

(author translation 1987, 41).

The section below examines the rhetoric used by the civilian and military leaders to identify and characterize the opposition. Defining the terrorist threat in broad strokes indicates not only a greater probability that the state will commit human rights violations, but also against whom those violations will be perpetrated.

### **Quién Habla es Terrorista (He Who Speaks is a Terrorist): Identifying and Framing the Opposition<sup>82</sup>**

The Ministry of Defense's White Book defines national security threats as those who participate in:

terrorist and subversive groups, which opposed constitutional order and choose to engage in violence; radical groups that promote social violence and excesses; organized crime; drug trafficking; corruption; and environmental degradation.

(author translation, Ministry of Defense 1995, 63)

Military manuals in effect during the conflict characterized the opposition in the following way:

---

<sup>82</sup> "Quién Habla es Terrorista" is the title of an article by Jo-Marie Burt on the spread and political manipulation of the fear of the civilian population during Fujimori's government.

[t]he subversive war, in addition to not being a conventional war, also can be classified as an extremely dirty and repugnant war, because when the Communists – there is no greater terrorist than the Communist – becomes a guerrilla he does not oblige by even the most basic of principles that governs civilization: treason, betrayal, jealousy, trickery, maliciousness, crime, treachery, and the ignoble qualities are considered appropriate and valid resources to break those loyal to the legal government.

(author translation, CAES 1987, 41)

The armed forces erroneously viewed the Shining Path as representing a comprehensive Communist assault on the state. In the Army's handbook, *Subversión: Ideología y Doctrina, Aplicación por los Movimientos Subversivos en el Perú* (Subversion: Ideology and Teachings, Application for Subversive Movements in Peru), both the Shining Path and the MRTA are discussed within the regional historical context of the armed revolutionary movements in Cuba, Bolivia and Nicaragua. Throughout the text, the notion is reinforced that the SL was part of an international Communist movement and a manifestation of East-West conflict during the Cold War era. According to Brigadier General Roberto C. Noel Mora (who served as commander of the Army's counterinsurgency campaign under President Belaúnde), the military was so convinced of this connection that they frequently ordered reinforcements and additional preventative measures be taken to provide for the nation's security on July 26, expecting that the Shining Path would commemorate the anniversary of the Cuban Revolution with a wave of attacks (CVR 2003).

Believing that the SL was a revolutionary organization in the same way as the *Frente Farabundo Martí para la Liberación Nacional* (FMLN, National Liberation Front of Farabundo Martí) in El Salvador or the *Frente Sandinista de Liberación Nacional* (FSLN, Sandinista National Liberation Front), the government and armed forces significantly overestimated the degree of civilian support for the group and mistakenly

believed that the civilian population not only shared in their ideological orientation but also that they actively supported Shining Path operations. Little effort was made to distinguish between active cadre and the peasants who lived in communities where the SL operated. For example, when responding to allegations of indiscriminate state violence, Lieutenant Colonel Javier Rivas Ramírez, commander of the Los Laureles army base in Tingo Maria, Huánuco, said that the entire community supported Sendero. When asked how the army differentiated between small children and Shining Path militants, Rivas replied that they were all terrorists (NSA April 20, 1994 “Eyewitness Reports from the Killing Site”).

Consequently, the state viewed with equal suspicion all members of the left, including the IU, the *Confederación General de Trabajadores del Perú* (CGTP, General Confederation of Workers of Peru), non-governmental human rights groups and local community organizers (see Figure 4.3 below). Those who questioned the state’s counterinsurgency policies or the practices of the armed forces were accused of being complicit or apologists for terrorism.



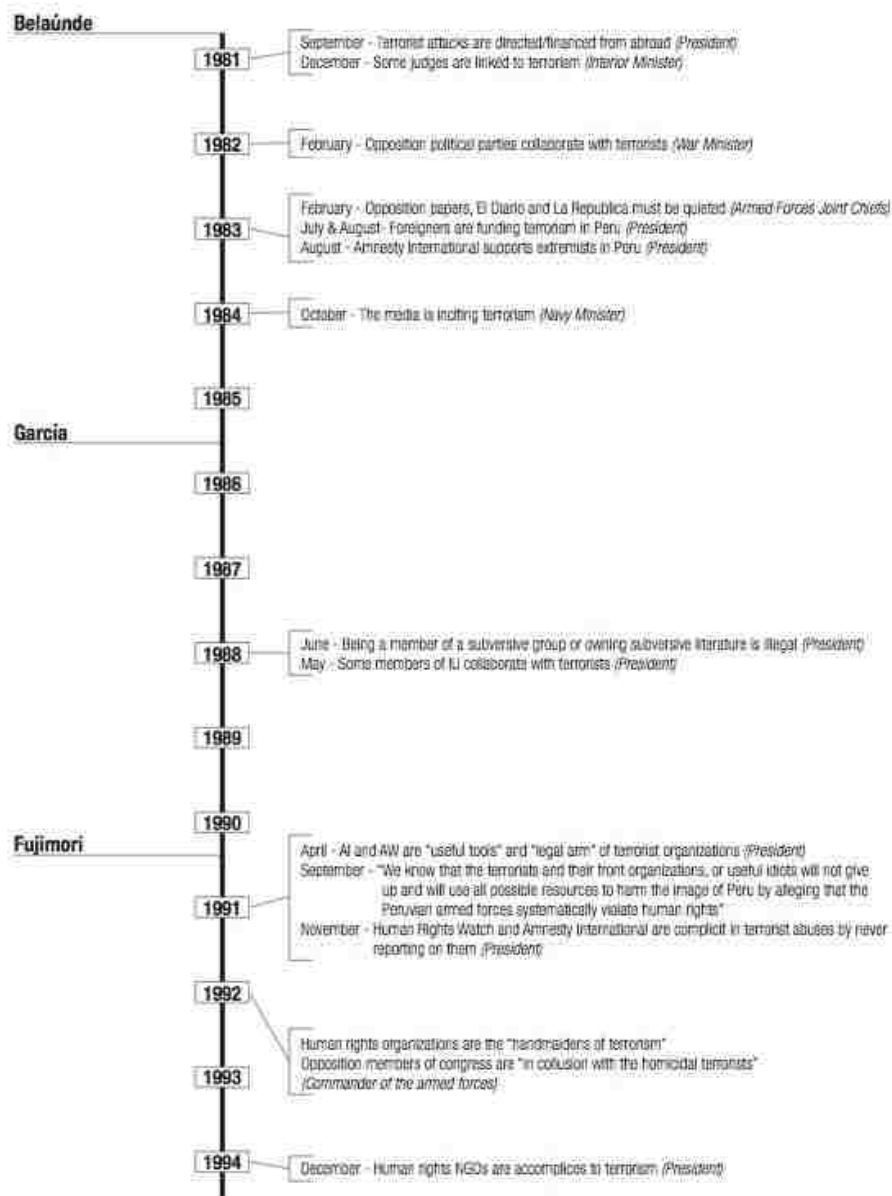

**Figure 4.3 Defining and Framing Terrorism, Selected Statements**

For example, in an interview with the CVR in 2003, General Noel lambasted the media as biased and supporters of the Shining Path:

The directors and journalists that wrote in opposition to the armed forces encouraged the subversives....the Intelligence [agencies] know how much

pro-Communist agitation and propaganda exists within these organizations.

(author translation, CVR 2003, 67)

Even the respected International Committee of the Red Cross (ICRC) was not safe from the disparaging verbal assaults of the state. Throughout the conflict, the ICRC repeatedly demanded access to inspect military bases and state-run detention facilities. In response to one of these demands in 1994, Army Brigadier General Alfredo Rodríguez Riveros, politico-military commander of the Huallaga front, strongly criticized ICRC delegates for aiding the terrorists: “[t]he ICRC always seems to know when and where the army is going to carry out an operation....They go in and converse with terrorist communities. And they come out with information” (NSA April 25, 1994 “Witnesses to Alleged Army Killings Come Forward; Army General Accuses ICRC of Aiding Terrorists”).<sup>83</sup> Rodríguez went on to complain that the ICRC interferes with the capture and interrogation of suspected terrorists because its delegates insist on interviewing detainees, after which the prisoners are uncooperative. Even the Chairman of the Congressional Human Rights Committee accused the ICRC of colluding with the terrorists. *Cambio 90* Congressman Carlos Blanco Oropeza stated that he had spoken with a repentant terrorist who told him that the ICRC offered him ten airplane tickets to help him and his family leave Peru if he would agree to stonewall the authority’s investigation (NSA April 25, 1994 “Witnesses to Alleged Army Killings Come Forward; Army General Accuses ICRC of Aiding Terrorists”).

That this assumption continued to inform the counterinsurgency policy and strategy of the state, even after numerous deadly assaults by the Shining Path on members of the

---

<sup>83</sup> Under states of emergency, the President appoints a military officer to serve as the politico-military commander and administrative authority of the affected area.

Peruvian left, reflects either an enormous intelligence failure on the part of the state, or a deliberate intention to attack the democratic and nonviolent opposition with equal repression as the armed insurgency.<sup>84</sup> For example, in addition to the frequent accusations and verbal assaults from the government, the opposition political party, IU, was also considered by the SL to be its greatest enemy (Burt 2006). As one community leader reported, “While [the state] threatened our leaders by detaining them and sending them to prison, [Sendero] threatened them to, accusing them of being traitors and a series of other things” (qtd in Burt 2006, 40).

While the government consistently identified the opposition in such broad terms as those described above, each President adopted a somewhat unique strategy to defeating them. The sections below describe in greater detail the state’s counterinsurgency strategy and the changes therein adopted by Presidents Fernando Belaúnde Terry (1980-1985), Alan García (1985-1990) and Alberto Fujimori (1990-2000). Under each presidential administration, an emblematic human rights case or military operation will be discussed to highlight the key characteristics of the government’s counter-terror efforts during that period. Chapter 7 will show how these changes in policy orientation resulted in observable changes in the patterns and repertoire of violence employed by the state.

### **Política del Avestruz (A Policy of Ostrich): Belaúnde’s Missing Counterinsurgency**

#### **Strategy**

---

<sup>84</sup> That some of the same organizations when mobilized in opposition to the state’s policies are still *today* described as terrorists, suggest evidence of the latter scenario – that the state uses the real fear of the civilian population of the threat of terrorism to discredit and defeat non-violent political opponents. For example, in 2008, the morning of a nation-wide strike by the CGTP, the following messages were displayed throughout the streets of Lima: “No al Paro, No al Terrorismo;” “No al Paro Terrorista/Comunista;” and “Yo Amo al Perú, No al Paro.” Similarly, in March 2008, President García openly criticized the campaigns and activities of the *Asociación Pro Derechos Humanos* (APRODEH, the national Human Rights Association) as tantamount to “treason against the fatherland.”

Under Belaúnde's leadership, the Peruvian state consistently misunderstood the nature of the Shining Path insurgency and underappreciated its strength. Figure 4.4 below provides an overview of the government's assessment of the relative power of the Shining Path during these early years of conflict. Few within the government considered the rebel group a serious threat to the new democratic regime. Consequently, the state's counterinsurgency strategy was delayed, unorganized and inadequate to deal with the subversive challenge of the Shining Path.

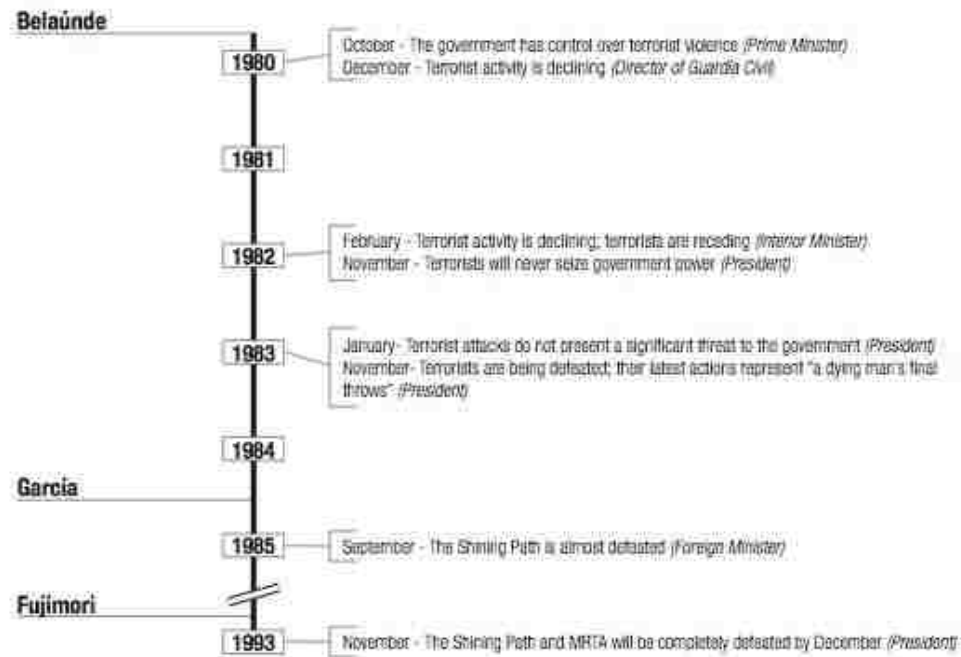

**Figure 4.4 Assessment of the Strength and Threat of the Shining Path**

As described above, the Shining Path carried out its first violent assault on May 17, 1980, unequivocally indicating to the government its intention to wage a violent war against the state and its democratic institutions. Seven months later, President Fernando Belaúnde Terry ordered the mobilization and deployment of the police to the central

sierra.<sup>85</sup> During this delay, the Shining Path capitalized on the absence of state security institutions to disseminate its propaganda, carry out additional attacks (including a symbolic attack on the grave of General Velasco) and steal weapons and other resources from poorly guarded remote police posts and mines.

The police, angered by their deployment to the “hinterlands,” and the lack of military reinforcements, made few advances on the battlefield.<sup>86</sup> The Shining Path strategically established its bases in the southern Andes, a region of the country that historically had been ignored by central government leaders and institutions. The relative absence of authorities, including the police, made it easier for the Shining Path to establish swathes of territorial control and made it more difficult for the state to gather intelligence on the armed revolutionary movement. With little information on the SL, its members, or the culture of the largely indigenous communities within which they operated, the police were unable to build crucial networks of alliances amongst the civilian population, a failure that severely hampered their counterinsurgency efforts. Indeed, the only significant counterinsurgency successes during this initial period of intervention occurred in Lima, where the police were able to capture large numbers of Shining Path militants and supporters.

The intelligence failures of the government cannot be overstated and began with the inattention of the military government of Francisco Morales Bermudez Cerruti to the

---

<sup>85</sup> Phase I of the state’s national security doctrine, *Defensa Interior del Territorio* (DIT, Doctrine of Internal Defense), calls for the police to prevent the expansion of the insurgency and to restore order. Only if the police fail to do so can the President activate the armed forces. Until 1985, the national police force consisted of three independent branches: the *Guardia Civil* (GC, Civil Guard), which is the largest of the three, the *Guardia Republicana* (GR, Republican Guard) and the *Policía de Investigaciones del Perú* (PIP, Peruvian Investigative Police).

<sup>86</sup> Deployment to the rural countryside, where resources were limited, weather and terrain conditions were formidable and general creature comforts common in urban centers were lacking, was seen by many to be a demotion.

initial formation and early movements of the Shining Path in the late 1960s and early 1970s. Interior Minister Luis Percovich argued that the military government refused any responsibility for confronting the Shining Path, kept no records on their activities, and worse still left office having completely dismantled the Ministry of the Interior, which come December 1980 would be at the forefront of the war against terrorism. Moreover, the police suffered basic tactical shortcomings, including insufficient communications equipment and gear, making police patrols and stations easy targets for SL attack.

As a result, morale within the police force was low. Officers' sense of duty and commitment to their posts wavered. Desertion was not uncommon; many officers abandoned their posts, shut down their stations and fled.

[The] police justified [their] poor performance by magnifying the numbers of their adversaries in their reports. There were intelligence failures of evaluation, distribution and implementation. Moreover, ...the police were not so much pinned down in their respective headquarters by overwhelming firepower, as they were unwilling to leave the relative security of their havens to do battle.

(NSA April 23, 1982 "Peruvian Terrorism: The Government's Response")

The early successes of the Shining Path, in particular their ability to grow and control territory in areas of Ayacucho and Huancavelica, had as much to do with the inadequacy of the state's response as they did with the capabilities of and support for the rebels. Illustrative of the state's ineptitude, in 1982 a band of SL militants successfully attacked the CRAS prison in Ayacucho city, freeing 304 inmates, including more than 50 *Senderistas*. The police were unable to repel the onslaught, and despite the presence of a contingent of soldiers at a nearby base, the military were not authorized to intervene. Immediately following the attack on the prison, a group of *Guardia Republicana* (GR, Republican Guard who during this time were in charge of securing the national prison

system) extrajudicially executed three wounded *Senderistas* in police custody at a hospital in Huamanga.<sup>87</sup>

Between 1981 and 1983 the Shining Path sharply increased the number and intensity of their assaults on the state. By the end of 1982 it was clear that the police would be unable to unilaterally defeat the insurgency. Many, including those in the government and armed forces began to apply pressure on President Belaúnde to activate the military and use greater force against the “terrorists.”<sup>88</sup> In March 1982, the Minister of War and head of the Joint Command of the Armed Forces, Luis Cisneros Vizquerra, announced that the armed forces “have their motors running” and are simply awaiting the order from the President. Belaúnde’s hesitance to call in the military is attributable, at least in part, to his fear that once empowered, the armed forces would again force his removal from office. While he publicly cites the cost that a major military operation would entail, “the underlying reason is almost certainly Belaúnde’s concern that once the military are back on stage, they may begin to write their own script” (NSA April 23, 1982 “Peruvian Terrorism: the Government’s Response”).<sup>89</sup>

The military received their first call to action in December 1982, two years after the onset of civil war. In accordance with Phase II of the DIT and Article 231 of the 1979 Constitution (see Table 4.4 at the end of the chapter), which allow the armed forces

---

<sup>87</sup> Displays of frustration and retributive violence such as this were not uncommon following SL attacks on military or police installations, particularly those attacks that resulted in state casualties. For example, in May 1988 an army patrol was ambushed by the Shining Path in the town of Erusco in Cayara, Ayacucho. An army Captain and three soldiers were killed in the attack. The following day, soldiers arrived at the village and executed between 28 and 31 peasants. Four days later, the soldiers returned again, this time detaining the survivors of the massacre, all of whom later disappeared. A subsequent Congressional investigation found that the army summarily executed the witnesses to the massacre.

<sup>88</sup> While the Shining Path was undoubtedly the most significant threat to the Peruvian state, the emergence of the MRTA in 1982 and their declaration of war in 1984 contributed to the national security crisis during this period.

<sup>89</sup> During his first term in office (1963-1968), President Belaúnde faced multiple, although smaller in scale, rebel movements in Cusco. Many believe that the military intervention to Forced to request military intervention to put down those insurgencies

to assume political authority of areas under states of emergency, Brigadier General Roberto C. Noel Moral accompanied by 2,000 soldiers, took control of the emergency zones in Ayacucho. They were instructed to take “decisive forceful action to restore order” and ensure a quick victory over the insurgents (NSA December 28, 1982 “Peruvian Army Continues ‘Preparations in Ayacucho’”). As General Noel recalls, the final orders of the President were clear: “[t]he President said to me, ‘General, fight with all your energy; you have the total support of the Constitutional Government’” (CVR 2003, 65).

General Adrian Huamán Centeno, a native Quechua speaker, replaced General Noel as commander of the emergency zone in Ayacucho in January 1984. General Huamán was well known for his outspoken criticism of the government’s counterinsurgency strategy, favoring instead direct investment in social development programs. In an interview with *La Republica* in 1984, the General said:

The solution is not a military one...if it were, the problem would be resolved in minutes...If we continue to kill, Ayacucho will be destroyed within half an hour, Huancavelica too. We have been handed the problem, but this is not the solution. What’s happening is that we are talking about human beings, communities that have been forgotten, that for 160 years have been clamoring, and no one has taken up their case, and now we are seeing the result....What has Ayacucho gained since Independence? ...Lima is seen as Peru, while the people in Ayacucho [are ignored] and forced to starve to death. To me, the solution is to rectify this situation. That is to say, don’t fill the prisons with innocent people who have never been properly tried...[instead] bring the people seeds and fertilizer...Perhaps we can think about what is going to resolve the real disease....

(La Republica Aug 1984)

Two days after making this statement, the politico-military commander was relieved of his duties and appointed Military Attaché to Mexico, illustrating the Belaúnde’s



willingness to enforce its counterinsurgency vision over that of the armed forces and to break ties with those who refuse to tow the line.

The data presented in Chapters 5 and 6 will show that this was one of the most lethal periods of the civil war. Between 1983 and 1984, more than 5,000 people were killed in Ayacucho alone, a department with no more than 500,000 people (Degregori and Rivera 1993); an additional 2,000 people were arbitrarily detained and/or disappeared (Cornell and Roberts 1990). This increase in violence was expected and indeed foreshadowed by earlier statements made by War Minister Vizquerra in an interview with *Quehacer*:

We are professional soldiers and we are trained to kill...The only way to ensure success [in Ayacucho] is to begin to kill Senderistas and civilians alike. We may kill 60 people and at most 3 are Senderistas...and surely the police would say that all 60 were Senderistas.

(author translation, CVR 2003, 256)

In his final public address before leaving office, Belaúnde confessed that his administration was unable to solve the problem of terrorist subversion in Peru and hoped that the next administration (of Alan García) would be able to do so. The following section, which details the counterinsurgency strategy of the García government between 1985 and 1990 and reveals that while initially the President initially expressed interest in changing the state's security policy, by the second year of his administration, accepted the armed forces' use of violent repression.

### **Great Expectations: Alan García's Promise of Change**

*... We will not withdraw one single step in the face of terrorism... We will combat terrorism, but will not accept human rights violations....[T]he use of death as a means to an end is unacceptable under a democratic system....The law will be strictly applied to those who violate human rights by assassinations, extrajudicial executions and torture....We will not fight barbarity by resorting to barbarity....If conditions permit, we will*

*consider the possibility of acts of grace, pardon and amnesty for those who have committed subversive crimes.*

(Alan García inaugural address July 28, 1985)

The young, charismatic candidate of the reformist *Alianza Popular Revolucionaria Americana* (APRA, American Popular Revolutionary Alliance) party, Alan García campaigned on a platform of change in the state's counterinsurgency strategy as well as its human rights practices.<sup>90</sup> It appeared as though the President was committed to change, not just in rhetoric, but also in practice. The President established the *Comisión de Paz* (Peace Commission) not only to begin an open dialogue between the rebels and the government, but also to investigate the legal status of the thousands of accused "terrorists" that had been detained since the beginning of the war.

Just two months into his presidency, García's resolve to improve the state's human rights record was tested when authorities uncovered the remains of 69 people in a mass grave in Accomarca, Ayacucho.<sup>91</sup> The President's response added credibility to the government's promise of change. For the first time since the beginning of the war, the President openly criticized the armed forces for violating human rights. He ordered an investigation of the entire chain of command to identify those involved in the massacre

---

<sup>90</sup> The party of Víctor Raúl Haya de la Torre, APRA was founded in 1924 as an anti-imperialist, left-leaning political party. While still a member of the Socialist International coalition, one could argue that today's APRA, which has embraced the neoliberal economic platform, party bears little resemblance to its historical roots.

<sup>91</sup> On August 14, 1985, an army patrol under the command of Lt. Telmo Hurtado Hurtado tortured and executed 30 women, 23 children and 16 men in the community. According to the testimony of a former soldier involved in the incident, Lt. Hurtado was ordered by superior officers to not leave any survivors or witnesses (Páez 2008). The soldier further testified that the operation was part of "Plan Quebrada de Huancayocc" designed to eliminate the *Senderistas* hiding in Accomarca. The Lince 6 and 7 patrol units were told that "any villager appearing in Quebrada de Huancayocc should be considered a communist terrorist" (CJA 2008). Almost ten years after the massacre, in 1993, Lt. Hurtado was prosecuted and convicted in a military tribunal for abuse of authority (the Military Code of Justice does not include torture or murder as offenses). His sentence of six years imprisonment was never enforced. When the amnesty law was revoked in 2002, Hurtado fled to the U.S. In 2007, he was arrested for failing to report that he was a convicted criminal on his Immigration and Customs form. He is scheduled to be deported to Peru (CJA 2008).

and subsequently fired the military commander of Ayacucho, General Sinesio Jarama and the politico-military commander of the emergency zone, General Wilfredo Mori.

However, less than a year later, President García's changed his tone. He began to indicate that the government would do whatever was necessary to defeat the terrorists:

It is not that our perspective or attitude changed after July 28 [inauguration day], but that we had to govern. The people expect you and are asking you to prevent future blackouts in Lima, to stop the killing, and to end the [omnipresent] bad news in the papers.

(author translation, CVR 2003, 68).

By 1986, the state's commitment to defend and protect human rights was clear. The section below considers in detail the coordinated prison riots in June 1986, riots that were made possible by the state's ill-conceived prison security system. More importantly, the response of the government and the armed forces to the riots is emblematic of the shift in the state's counterinsurgency strategy under President García.

So fearful of the spread of Communism and SL propaganda, the state overlooked the security risk of housing all political prisoners in the same cellblock in order to segregate them from the general prison population. As a result, political prisoners were able to continue to organize, mobilize and in some cases, even arm themselves in resistance to state security officials. As José Luis Pérez Guadalupe has described, the result of this ill-conceived policy was the abdication of state control and authority within the prisons to the prisoners themselves. Of the environment at San Juan de Lurigancho, he notes:

...the Lurigancho prison is the only prison of its size in the world where the prisoners have the keys to their cells, are in charge of internal security (can enter and leave any cellblock), cook their own food, establish and carry out punishments [including the death penalty] for those who break the rules, have knives, sticks, guns and explosives, ...in other words, it is

the very same prisoners and not any external authority, who establish the norms of the prison and for living together...

(1994, 199)

The crisis of state control inside the El Frontón prison was so severe that in one of the cellblocks, prisoners had constructed a system of reinforced bunkers and tunnels, described by one observer as “a veritable fortress impregnable to security forces for the past five years” (NSA June 20, 1986 “Recuperation of Prisons: Political Consequences”). There is no doubt that the state’s handling of prison security contributed to the 1986 riots.<sup>92</sup>

On the morning of June 18, 1986 (the same day as the Socialist International meeting in Lima), political prisoners from the San Juan de Lurigancho, El Frontón and Santa Bárbara prisons simultaneously rioted, taking several guards hostage, to demand better living conditions and the guarantee of their civil liberties. Within hours, President García declared a state of emergency in Lima and Callao and ordered the armed forces and the GR to take back the prisons by force. During the assault, 300 prisoners were killed, including more than 100 who were extrajudicially executed after surrendering to authorities.

In the aftermath of the massacre, President García ordered a nonpartisan Congressional investigation, led by Senator Rolando Ames, of the soldiers and GR involved.<sup>93</sup> Investigations revealed that the prisoners at San Juan de Lurigancho were

---

<sup>92</sup> In fact, there were multiple incidents before the 1986 prison riots that indicated the imbalance of power between the prisoners and security officials. In April 1985, prisoners at El Frontón took eight guards hostage; the incident was resolved without injury. Three months later, prisoners at El Frontón, Santa Bárbara and San Juan de Lurigancho coordinated simultaneous riots. Another riot in San Juan de Lurigancho in October 1985 resulted in the death of 30 inmates. Moreover, many suspect that throughout the war, SL attacks and operations were ordered and planned from behind the walls of the El Frontón and Lurigancho prisons. That the prison population continues to be segregated in this way is curious.

<sup>93</sup> Senator Ames has indicated that had there not been a strong presence of international journalists and representatives attending the Socialist International Meeting, García probably would never have complied

not heavily armed (a fact later confirmed by Manuel Aquezolo, the director of the National Penitentiary System), suggesting that the combined police and military forces should have been able to recover the prisons without excessive violence.

In describing the massacres, García indicates his priorities to the population, including members of the armed forces. He states that while he would have preferred it to not happen this way, the “fact remains that a great number of terrorists [have] been eliminated” (NSA July 1, 1986 “President García Says Crisis is Over”). He further argued that there is no alternative when waging a war against domestic terrorism and that the “Peruvian people had to learn to live with a high level of violence” (NSA July 1, 1986 “President García Says Crisis is Over”). Finally, the decision to promote the former Minister of Justice Gonzalez Posada, who resigned from his post after the prison massacres, to Ambassador to the Organization of American States (OAS) calls into question the President’s genuine commitment to guaranteeing the human rights of the Peruvian people.<sup>94</sup>

After the prison massacres, the Shining Path continued to gradually increase the intensity and frequency of its operations, notably expanding their reach beyond their strongholds in Ayacucho and Huancavelica into Puno and Junín in the upper Huallaga river valley. They also markedly increased the frequency of their attacks in Lima, targeting elected officials, political party members and community leaders for assassination. The latter attacks brought the war to the most populated, affluent and

---

with demands for such an investigation. Members of the Dutch, Belgian and Scandinavian delegations repeatedly called for conference representatives to issue a public statement condemning state violence against the prisoners (Feinstein 2011, NSA June 23 1986 “GOP Orders Investigations of Prison Deaths”).

<sup>94</sup> At the time, the Ministry of Justice administered prison facilities.

otherwise sheltered areas of the capital, terrorizing the urban middle class and displaying the impotence of the central government.<sup>95</sup>

Corresponding to the increased threat of the Shining Path, the state expanded and intensified their counterinsurgency efforts. The central government issued new comprehensive anti-terrorist legislation (see Table 4.4), which defined terrorism so broadly as to include any act “committed with the intention of altering or destabilizing the constitutional system or affecting the security of the state” (Cornell and Roberts 1990, 538). Anyone belonging to or associating with members of subversive organizations (understood as groups of two or more people), anyone advocating the use of violence or expressing sympathy for those who did, could be prosecuted for collaborating with terrorists and faced up to 15 years in prison (Law 24953). Law 24953 additionally removed the few remaining guarantees and protections afforded to those accused of terrorism.

With these changes came a sharp increase in the number of human rights violations perpetrated by state security officials (in comparison to the first 1-2 years of the García administration, but remained lower than the very high levels of generalized violence of Belaúnde’s final two years in office). The number of arbitrary detentions increased, accusations of torture against the state increased, and the number of political disappearances increased so high as to earn Peru the regrettable distinction of having the most forced disappearances in the world in 1987, 1988 and 1989 (UN Working Group on Enforced or Involuntary Disappearances UN Doc E/CN.4/1988/19 at 49 (1988) and UN

---

<sup>95</sup> That a July 1992 SL attack in Miraflores is considered by some to be the “worst single terrorist incident” during the war, is due, in part, to the ethnic and class background of those killed and injured. This attack, unlike the hundreds that occurred before it in the central sierra, was designed to intimidate and terrorize the upper middle and wealthy classes of Lima.

Doc E/CN.4/1989/18 at 61-64 (1989), see also Basombrío 2001, Degregori and Rivera 1993).

The next section outlines the counterinsurgency policies of Alberto Fujimori. More than the previous two administrations, Fujimori's carried out an integrated and coherent counterinsurgency strategy that divided and specialized the efforts of the police and armed forces. While separate, their work was mutually supportive.<sup>96</sup> The military would continue offensive missions in designated areas while the police would collect intelligence on the location and movements of the subversives. At the same time, the civilian population would be incorporated directly into the state's counterinsurgency operations through the peasant self-defense militias. These changes resulted in a reduction in *some* forms of state abuse, particularly mass, indiscriminate acts of violence; those that remained, however, were premeditated (CVR 2003).

### **La Mano Dura de Alberto Fujimori**

*My government is the product of rejection, of Peru's fatigue from frivolity, corruption and inefficiency of the traditional political class....[T]he people who voted for me are tired and weary of this false Peru.*  
(qtd in Burt 2008, 68)

Frustrated by the worst economic crisis in the country's modern history as well as the apparent inability of the state to defeat the Shining Path, in June 1990, Peruvians elected Alberto Fujimori, a political outsider whose campaign platform promised a gradual economic reform program and a firm hand to defeat domestic terrorism.<sup>97</sup> In

---

<sup>96</sup> For example, according to Directive N.017 for Internal Defense issued by the Joint Command of the Armed Forces, the military would reorganize and focus their counterinsurgency efforts in designated zones. These zones were so designated after careful study of the operations and movements of the Shining Path; these surveillance missions were usually carried out by the police (CCFFAA 1989).

<sup>97</sup> In the two years before Fujimori's inauguration, inflation rose from 1,722 percent in 1988 to 2,775 percent in 1989 (CVR 2003). Soon after assuming office in July, Fujimori broke his campaign promise for an easy, smooth economic restructuring. Instead, he implemented a neoliberal austerity program that became known as "Fujishock." He drastically reduced state subsidies, set the inti (the national currency

short order, Fujimori demonstrated his willingness to do what he saw as necessary to carry out his socio-political agenda. Those that stood in opposition, whether individuals, institutions or the Constitution itself, could be eliminated, disbanded or replaced. The following section will detail the increasingly authoritarian measures employed by the Fujimori government in order to eradicate the Shining Path. During his administration (1990-2000), the state implemented three significant changes to its counterinsurgency strategy: (1) a greater emphasis on civilian support for military operations, (2) a greater emphasis on the intelligence efforts of the police, and (3) sweeping changes to the legal code to broaden the understanding of domestic terrorism and increase the penalties for those involved (see Table 4.4).<sup>98</sup>

The 1989-1990 army manual, *Manual de Ejército Guerra No Convencional Contrasubversión ME 41-7* (Army Manual for Unconventional Counter-subversive War), describes counterinsurgency as:

[a] set of ordered actions in all areas of human activity, carried out throughout the entire country with the objective of prevention the assumption of power, the destruction of the foundation of the country and the creation of bases on which the subversives intend to build a new foundation of society.

(author translation, CVR 2003, 286)

The manual repeatedly underscores the importance of civilian support for military operations and recognizes that without it, success will be difficult, if not impossible to achieve:

---

between 1985-1991) to the US dollar, began to negotiate the repayment of foreign debts, and eliminated barriers to foreign investment and imports. Overnight, the price of a gallon of gasoline exploded from \$0.13 to \$4.00. The most devastating effects were felt in the dramatic increase in the cost of milk, bread and other foodstuffs, many of which were now out of the reach of the urban and rural poor (Brooke 1990).<sup>98</sup> The first and second of these policy changes began at the end of García's government, but did not really take effect until Fujimori assumed office in 1990.



[i]t is relatively easy to shoot at and expel the subversive forces from an area with military action, just as it is possible to destroy the political organization through intensive police action, but it is almost impossible to prevent the return of the guerrillas and the reorganization of their political cells without the cooperation of the civilian population.  
(author translation, CVR 2003, 287).

It goes on to describe that in any area of contention, there is always an active minority that is in support of the state and the government's initiative, just as there is always a minority that is in direct opposition to the objectives of the state. The majority of the civilian population is neutral. The objective of the military's counterinsurgent operations, then, is to employ the supportive minority to elicit the cooperation of the neutral majority.<sup>99</sup> To do this, the armed forces must:

1. Instruct [its members] how to observe/study the population, to understand their customs, traditions, idiosyncrasies, and beliefs.
2. Always maintain a courteous and respectful attitude of deference when approaching the civilian population.
3. Respect the customs and traditions of the population.
4. Provide a fair price to vendors when renting or consuming goods in zones of operation.
5. Forbid its members from stealing or charging "fees" to the civilian population.<sup>100</sup>
6. Respect the fundamental rights of the people, with the exception of those suspected during states of emergency in accordance with Article 231 of the Constitution.
7. Avoid abuses of authority against the civilian population.

(author translation, CVR 2003, 288).

Up until this time, the armed forces had been largely ineffective at gaining the trust and cooperation of the civilian population. Recounting an exchange with an anonymous officer in the Peruvian army, a US embassy official reported that:

---

<sup>99</sup> The recognition in their training manuals that the majority of the civilian population was likely not aligned with the subversives contradicts the statements frequently made by civilian and military leaders (see above section, *Quién Habla es Terrorista*) and suggests a political motive (not a national security imperative) for such accusations.

<sup>100</sup> It was not uncommon, for example, for security officers to demand some form of payment – food, livestock, money or sexual services – in exchange for the release from custody of a loved one. Compliance did not always secure the prisoner's freedom.

the army has yet to figure out a way to beat SL. The SL are mostly from Ayacucho and are Quechua-speaking. Army patrols always have at least one Quechua speaker..., but are still regarded as foreigners. The SL are better acclimated, know the territory better and are more strongly motivated...Moreover, ...soldiers are marking the days of the calendar until they can leave...[He] readily volunteered that the army was not winning the local population over.

(NSA November 29, 1988 "Visit to Ayacucho")

In this regard, the role of the CADs became instrumental to the state's counterinsurgency plans.<sup>101</sup>

While the first attempts to organize the civilian population into self-defense militias occurred in 1984, they did not become an integral part of the state's counterinsurgency strategy until 1989-1990 with the incorporation of the *Comites de Autodefensa* (CAD) into the operations of the armed forces, a process made formal under Legislative Decree 741 (see Table 4.4).<sup>102</sup> Once legalized, the groups proliferated and the flow of weapons from the state expanded.<sup>103</sup> Between 1989 and 1991, the number of CADs increased by 500; between 1991 and 1997 they grew by another 1300 groups (Fumerton 2002). These peasant militias often carried out joint operations with the military. They would provide vital information on the local population and terrain.

While the army (and CADs) pursued the subversives in the countryside, the police carried out population control measures more reflective of their institutional mandate. In

---

<sup>101</sup> On the disparate history of the *rondas campesinas* and CADs, see Starn 1993 and Fumerton 2002. Throughout the chapter, the terms CADs, peasant self-defense militias and *rondas* are used interchangeably.

<sup>102</sup> Emphasizing the role of the state in the organization and activities of the CADs is not to minimize the agency of the peasants, many of whom voluntarily joined the self-defense militias and/or were integral in the groups' leadership. The focus here is on the counterinsurgency strategy of the state and the extent to which that included the incorporation of the *rondas*.

<sup>103</sup> Under Belaúnde, the government refused to arm the self-defense militias, firing the military commander who pushed the initiative (Fumerton 2002). García was more willing to use the militias as an anti-terrorist fighting force, particularly towards the end of his administration when it was clear that his government's counterinsurgency strategy had failed. In fact, García himself personally financed the requisition of 200 shotguns to a peasant self-defense group in Tambo, Ayacucho (Fumerton 2002). However, under Fujimori, state financing and armament of the CADs grew exponentially. In 1991 alone, the government distributed more than 10,000 shotguns to the CADs (Starn 1998).

1990, the state established the *Grupo Especial de Inteligencia* (GEIN, Special Intelligence Group) in 1990. A special operations force of the *Dirección contra el Terrorismo* (DIRCOTE, Counter-Terrorism Directorate), the sole mission of the GEIN was to gather intelligence that would lead to the capture of the principle leaders of the Shining Path. The rationale was that given the highly centralized organization of the SL, if the state were able to capture the leadership, the group would effectively disintegrate.

Shortly after its inception, the capacity of the GEIN and other police units would be seriously challenged by the rise in Sendero attacks in the capital. In 1989, the group declared a strategic equilibrium in its war against the state, after which it made a strong push to take Lima by force. By 1991, there was a sharp increase in the number of terrorist attacks in the city, accompanied by rolling blackouts throughout the country that led many to wonder if a Shining Path takeover of the central government was imminent.

The real threat of terrorist violence provided the perfect opportunity for the President to consolidate his power and carry out his political agenda.<sup>104</sup> On April 5, 1992, Fujimori led an *autogolpe* (self- coup), declaring that “the so-called traditional democracy...was unable to solve any of the major problems of Peru...” (NSA October 1, 1993 “Peru’s Fujimori Announces that Sendero Leader Guzmán is Disposed to Negotiate”). Fujimori argued that such extraordinary and unconventional measures were necessary in order to deal with the spread of corruption, the economic crisis and the terrorist threat of the Shining Path and MRTA: “[w]hat Peru need[s is] order, discipline, the principle of authority, good management – and an iron fist against terrorism” (qtd in Burt 2008, 68). The newly declared “National Reconstruction Government” shut down

---

<sup>104</sup> In fact, the *autogolpe* had widespread support amongst the population and even within the armed forces. According to one poll, a full 80 percent of Peruvians supported the coup (see Burt 2008).

Congress (governing instead by extensive executive decree), dissolved the judiciary, suspended the 1979 Constitution and deployed the military throughout the capital.

(Ab)Using his executive decree powers, between 1991-1995, Fujimori initiated sweeping revisions of the legal code, redefining the crimes of terrorism and treason against the fatherland and changing the process through which such crimes would be adjudicated (almost guaranteeing that those charged would be convicted and sentenced to life in prison). The result was the severe curtailment of civil liberties and political freedoms (see Table 4.4).

Less than a year after his coup, in September 1992, the GEIN captured the illusive leader of the Shining Path, Abimael Guzmán. In an act of unexpected capitulation, within a year of his arrest, the dogmatic Guzmán offered a negotiated settlement to the civil war. By 1995, the remaining leaders of the organization were either in state custody or dead.<sup>105</sup> By all accounts, the Shining Path was no longer a serious threat to the national security of Peru. Despite the frequent assertions by the administration that Guzman's capture and the subsequent recession of Shining Path violence was proof positive of the necessity of its authoritarian policies, the Shining Path's demise was more the result of successful intelligence and counterinsurgent operations by the police forces than it was the result of the coup:

---

<sup>105</sup> According to Ministry of Defense records, by 1995, most of the leadership of the Shining Path was either behind bars or dead: Guzmán and Elena Albertina Iparraguirre ("Miriam") of the permanent committee were both behind bars; Magie Evelin Clavo Peralta ("Nancy"), Rosa A. Salas de la Cruz ("Teresa"), Laura Zambrano Padilla ("Renee"), Osmán Morote Barionuevo ("Nicolas"), Margot Liendo Gil ("Noemi") of the central committee were also behind bars; and María Jenny Rodríguez Neyra ("Rita") and Victoria Obdulia Agurto ("Elizabeth"), candidates for the central committee were behind bars. Huago Deodato Juarez ("German"), Yobanka Pardave Trujillo ("Sarah"), "Marcelo," Elvia Nila Zanabria Pacheco ("Juana"), and "Remigio," of the central committee were all dead, as were Tito Roger Valle Travesano ("Eustaquio") and Julia M. Danles A. ("Vallia") supplement and candidate for the central committee, respectively (Ejército Peruano 1996, 206). While combatants continue to carry out subversive operations in the country, they are sporadic in nature and small in scale.

Guzman's arrest had little to do with the centralization of power and political repression associated with the autogolpe. The 'arrest of the century' was the result of years of laborious intelligence gathering by...DINCOTE...Not a shot was fired in the course of the arrest. ...[The arrest] had everything to do with good old-fashioned detective work, and it occurred squarely in the context of democratic procedures.

(Burt 2008, 68-69)

The massacre of nine students and a professor at the *Universidad Nacional de Educación Enrique Guzmán y Valle* (UNE, Enrique Guzmán and Valle National Education University, also known as La Cantuta) on July 18, 1992 illustrates the Fujimori government's willingness to carry out authoritarian and repressive actions in the name of fighting the war against domestic terrorism.

Members of the paramilitary death squad, *Grupo Colina*, along with members of the regular army entered the student dormitories at La Cantuta and kidnapped Luis Enrique Ortiz Perea, Armando Richard Amaro Córdor, Bertila Lozano Torres, Dora Oyague Fierro, Robert Edgar Teodoro Espinoza, Heráclides Pablo Meza, Felipe Flores Chipana, Marcelino Rosales Cárdenas and Juan Gabriel Mariños Figueroa. After proceeding to capture Professor Hugo Muñoz Sánchez, all ten detainees were taken from the University campus and disappeared. The entire incident was filmed by one of the soldiers and witnessed by friends and family members of the victims.

The bodies of the students and professor were later discovered in a secret grave at a water treatment facility that was being used as a firing range by the national police in Lima. Their remains indicated that each was severely tortured before being killed. Investigations into the massacre began after the perpetrators tried to disinter and move to another location the remains of the victims.

Like others associated with La Cantuta University, the victims were targeted for violence on the suspicion of being connected with the Shining Path. As one student recounts to the CVR:

Living on campus was difficult; the atmosphere was tense and violent. There was a military presence, under the command of Lt. Aquilino Portello Nuñez “Lt. Medina.” The military committed a lot of abuses against the students...It was dangerous to even carry a student ID on the streets; if the police saw it, they would accuse you of being a terrorist and detain you...[On campus] the military would...harass the students, calling them terrorists and threatening to disappear them.  
(CVR Testimony 700821)

Herself a student at La Cantuta, Marcelina\* continues to describe her own detention, torture and rape at the hands of the army, all while being interrogated for the names of other students on campus who “collaborated with the terrorists.”

When called before a congressional committee investigating La Cantuta massacre to testify, General Nicolás Hermoza Ríos (then Commander General of the Army) was outraged. He called the investigation an insult to the armed forces and ordered the dispatch of army tanks throughout the capital (NSA May 22, 1993 “Retired General on Plotting in the Army and La Cantuta Investigation”). He went on to argue that:

...some Congressmen from the opposition appear to be in collusion with the terrorists. They have mounted an egregious defamation campaign against the Peruvian army, undermining the confidence that the Nation and the people have bestowed to it...I will not tolerate this...  
(qtd in Degregori and Rivera 1993, 19).

According to a retired, senior ranking member of the army officer corps, these statements by General Hermoza likely came directly from Fujimori. Civilian and military leaders alike argued that continuing the investigations would compromise morale within the

---

\* All names have been changed.

army and undermine the state's counterinsurgency efforts (NSA May 22, 1993 "Retired General on Plotting in the Army and La Cantuta Investigation").

In 1994, ten soldiers were tried in a military court and sentenced to between one and twenty years for their involvement in the massacre at La Cantuta. However, all were subsequently released in June 1995 after the President signed into law an amnesty for all members of the armed forces and police who perpetrated human rights abuses during the civil war.

The case was later revisited by the Inter-American Human Rights Court in *La Cantuta v Peru* and the Peruvian Supreme Court in *Barrios Altos, La Cantuta and Army Intelligence Service Basement Cases*. In independent decisions, the courts determined that President Fujimori was the intellectual author of the La Cantuta massacre. The public prosecutor cited documentary evidence that Fujimori directly ordered the military to intervene at the University. According to testimony by General Hermoza at Fujimori's trial, Fujimori and his top advisor, Vladimir Montesinos, both knew of the massacre immediately following the attack.<sup>106</sup>

The first time a democratically elected head of state has ever been tried and convicted for crimes against humanity, Fujimori was found guilty of being the "perpetrator by means" of the La Cantuta massacre. For this, and other crimes, Fujimori was sentenced to 25 years in prison.

## **Conclusion**

This chapter provided a historical analysis of the Peruvian civil war between 1980 and 2000. It began with an overview of the primary armed opposition group, the Shining

---

<sup>106</sup> The Grupo Colina reported all of its activities to the *Servicio de Inteligencia Nacional* (SIN, National Intelligence Service) and Montesinos himself (Sala Penal Especial de la Corte Suprema 2009).

Path – the structure of the organization, its objectives and tactics and its leadership. The chapter then examined the state’s response to the SL insurgency. How did the state understand the threat posed by the Shining Path? How did it plan to defeat the rebels? As discussed above, the strategies and tactics employed by the state to combat the Shining Path changed over time, particularly across presidential administrations. Under the leadership of President Belaúnde, a president who had previously been deposed by the military, the government response to the Shining Path was delayed, unorganized and ill informed. By 1985, when President García assumed office, the state better understood the nature of the Shining Path, but still struggled to translate this information into battlefield successes. García’s administration is best characterized by the notable disjuncture between the President’s early rhetorical commitment to protecting human rights and avoiding a “dirty war” and his subsequent decision to not only allow but order the use of violent repression against the terrorists. Fujimori’s administration was highly organized and centralized. The government’s counterinsurgency strategy was more deliberate and focused and legitimized the use of repression against identified “enemies” to achieve its military and political objectives.

The human toll of twenty years of civil war is immense and likely immeasurable (Ugalde et al. 2000, Ghobarah et al. 2003). It is estimated that nearly 70,000 Peruvians lost their lives between 1980 and 2000 (CVR 2003).<sup>107</sup> The dead and disappeared left behind thousands of widow(er)s and orphans. Approximately 35,000 people were detained on charges of terrorism, half of whom were subsequently absolved of all charges (CVR 2003, 428). Nearly half a million people were internally displaced. The violence

---

<sup>107</sup> Earlier reports by the National Police and Ministry of Defense and local non-governmental organizations estimated that between 23,000 and 35,000 people were killed during the civil war (Bernaes, et al. 1989, DESCO 1989, PAR 2001).



has left a deep and lasting impression on the conflict-weary population. Feelings of generalized anxiety, fear and phobia, a sense of insecurity and impotence, loss of confidence and mistrust in others are not uncommon (Laplante and Rivera Holguin 2006).

The following chapters (Chapter 6 and 7) examine the frequency and patterns of wartime sexual violence. The analyses reveal that sexual violence was perpetrated instrumentally by state security agents during counterinsurgency operations. Sexual violence was used to punish and interrogate real or suspected political opponents and “terrorists.”

<b>President</b>	<b>Period of Governance</b>	<b>Mode of Entry to Office</b>
Ricardo Pérez Godoy	July 1962-March 1963	Coup d'état
Nicolás Lindley López	March 1963-July 1963	Coup d'état
Fernando Belaúnde Terry	July 1963-October 1968	Elections
Juan Velasco Alvarado	October 1968-August 1975	Coup d'état
Francisco Morales Bermúdez	August 1975-July 1980	Coup d'état
Fernando Belaúnde Terry	July 1980-July 1985	Elections
Alan García Pérez	July 1985-July 1990	Elections
Alberto Fujimori	July 1990-November 2000	Elections
Valentín Paniagua	November 2000-July 2001	Accession
Alejandro Toledo	July 2001-July 2006	Elections
Alan García Pérez	July 2006-present	Elections

**Table 4.3 Political Leadership and Regimes in Peru, 1962 to Present**

<b>Law</b>	<b>Date</b>	<b>Significance</b>
046	1981	First anti-terrorism legislation passed by the government: Regulates procedures for police to detain and interrogate those suspected of terrorism Police may detain suspects for up to 15 days, but Ministry of Interior and civilian judge must be notified of arrest within 24 hours. Interrogation of detainees must occur in presence of public prosecutor. Defined terrorism as “provoking or maintaining a state of fear, alarm, or terror amongst the population” and included such acts as “destruction or damage to

<sup>108</sup> Under this last provision, union leaders were sometimes arrested and prosecuted for crimes of terrorism for organizing labor protests and road blockades that disrupted the transportation system.

		public or private buildings, transportation or communications networks or the transport of fluids or power.” <sup>108</sup>
24150	June, 1985	Regulates presence of armed forces during state of emergency: Gives political authority during states of emergency to political-military command under jurisdiction of Ministry of Defense (no longer under civilian authority of Ministry of Interior). Establishes that crimes committed by military or police personnel in emergency zones are under military jurisdiction and to be tried in military tribunals.
24700	June, 1987	Regulates the detention, interrogation and adjudication of those accused of committing crimes of terrorism: Upon detention, the police must immediately inform the family of the accused, the Human Rights Commission and the public prosecutor in writing of the charges for which the detainee has been accused. Access to and participation of defense counsel is paramount and cannot be derogated.
440*	Sept, 1987	Establishes the legal authority of the Joint Command of the Armed Forces: The Joint Command of the Armed Forces is responsible for planning and coordinating military operations as they relate to both international and domestic security threats. The Joint Command of the Armed Forces is comprised of the Commanders General of the Army, Navy and Air Force.
24953	Dec, 1988	Establishes that intellectual authors and accomplices to terrorist actions will receive the same criminal punishment as the direct perpetrators of these acts. Establishes association, inciting and apologizing for terrorism as crimes: <ul style="list-style-type: none"> <li>• “Those who belong to any organization, made up of two or more people, whose purpose is to instigate, plan, facilitate, organize, or commit acts of terrorism, as defined in this Article, can be punished simply for associating members of such an organization, with a prison sentence of no less than 10 years and no more than 15 years” (author translation).</li> <li>• “Those who publicly or through any means of communication, incite someone to commit acts, such as those described herein, as well as those who defend or applaud an act of terrorism, or those who have committed such acts, will be punished with a prison sentence of no less than 5 years” (author translation).</li> </ul>
25103	Oct, 1989	Regulates the sentencing of those found guilty of crimes of terrorism: Sentences may be reduced/modified for those who voluntarily renounce their connection to terrorist organizations, who provide information to state authorities that results in the identification, location, operations of terrorist organizations and their members.
741	Nov, 1991	Recognizes the right of the <i>Comités de Autodefensa</i> (CADs, Self-Defense Committees) to defend their communities with arms and place the CADs under the authority of the politico-military command.
743	Nov, 1991	Redefines the structure of the state with respect to national security, shifting the focus away from international threats towards internal subversion. Increases powers of the armed forces, including allowing the military to enter territory outside of emergency zones. Gives armed forces direct role in political and economic decision making Legalizes the state armament of civilian self-defense patrols (CADs).
25475	May, 1992	Replaces Law 24700. Regulates the sentencing of those found guilty of crimes of terrorism, collaboration, affiliation, instigation, “apology,” obstruction of justice: <ul style="list-style-type: none"> <li>• A terrorist is defined as “[h]e who provokes, creates or maintains a state of fear or terror in the population...commits acts against life, limb, health, freedom and personal security, or against property,</li> </ul>

		<p>...public buildings, communication or transportation infrastructure, ...using guns, explosives, or any other weapon capable of causing havoc or serious disturbance of the public peace or affecting...the security of society and the State...” (author translation).</p> <ul style="list-style-type: none"> <li>• Collaboration includes “supplying documents or information about people and property, [military] installations, public and private buildings...that contributes to or facilitates terrorist activities; using a place of residence to hide persons, store weapons, explosives, propaganda, medical supplies or any other materials related to terrorist groups; knowingly transporting members of terrorist groups, or those connected with their activities, or providing any other form of help that may aid in their escape; organizing or conducting classes or indoctrination and instructional centers of terrorist organizations...; making, acquiring, having, removing, storing or delivering weapons, ammunition, explosive, asphyxiating, flammable, toxic materials or any other objects that could result in injury or death...; participating in any form of economic activity that may ultimately finance the activities of terrorist groups” (author translation).</li> <li>• Affiliates are those who “take any part in a terrorist organization” (author translation).</li> <li>• Instigation refers to “any means or methods of inciting someone else to commit an act of terrorism” (author translation).</li> <li>• An apologist is any person who “publically, through any means, makes an apology for terrorism or those who commit terrorist acts” (author translation).</li> <li>• Obstruction of justice occurs when someone “through any means, obstructs, impedes or makes difficult the investigation or adjudication of crimes of terrorism” (author translation).</li> </ul> <p>Establishes the procedures for investigating and adjudicating these crimes:</p> <ul style="list-style-type: none"> <li>• Crimes of terrorism are subject to mandatory minimum sentencing; judges cannot reduce sentences.</li> <li>• Individuals suspected of crimes of terrorism can be held for 15 days, after which they must be presented before the Public Ministry.</li> <li>• When circumstances require, an individual may be held in isolation with the acknowledgement and authorization of the Public Ministry.</li> <li>• The accused have the right to an attorney.</li> <li>• Trials will be carried out so that judges and members of the Public Ministry cannot be identified, by sight or sound, by the accused or their lawyers.</li> <li>• Lawyers cannot serve on the defense counsel for more than one trial regarding crimes of terrorism at a time.</li> </ul>
25499	May, 1992	<p>Regulates the sentencing of those found guilty of crimes of terrorism: Sentences may be reduced/modified for those who voluntarily renounce their connection to terrorist organizations, who provide information to state authorities that results in the identification, location, operations of terrorist</p>

		organizations and their members.
25659 <sup>109</sup>	Aug, 1992	Establishes the crime of “Treason against the Fatherland”: “Treason against the Fatherland” includes acts that meet the criteria established under Law 25475 <i>and</i> include the planting or detonating car bombs or similar explosives, carrying weapons, causing the death or serious injury (mental or physical) of someone, causing serious damage to public or private property, possessing illegal materials, such as ammonium nitrate or other substances used in the manufacturing of explosives. Leaders of terrorist organizations can be tried for treason against the Fatherland. Those charged with treason against the Fatherland will be tried by military tribunal.
25744	July, 1992	Establishes that acts of terrorism, which cause a loss in life, may be considered treason and tried in military tribunals.
25880	Nov, 1992	Specifies that those who serve as teachers or professors and apologize for terrorism will be considered the intellectual authors of subsequent crimes of terrorism and will be charged with treason against the Fatherland. Those charged with treason against the Fatherland will be tried by military tribunal.
26345	Aug, 1994	“Law of Repentance for the Crime of Terrorism”: Those who invoke the repentance law, renounce their connection to terrorist organizations and confess to their past actions may receive a reduction in their sentence by one-third to one-half of the minimum required years. Additional benefits include: anonymity, financial resources to relocate, if necessary.
Constitution	1979 1993	Article 231 establishes governmental powers during times of national crisis, such as during internal conflict or disturbances of the peace or other serious circumstances that affect the life of the nation: <ul style="list-style-type: none"> <li>• The President may suspend constitutional guarantees related to freedoms of movement and association and the sanctity of the home (granted under Article 2).</li> <li>• The state of emergency cannot last for more than 60 days, beyond this a new state of emergency must be issued.</li> <li>• During the state of emergency, the armed forces assume control of internal security and public order.</li> </ul> Article 229 limits the powers of the President during states of emergency by prohibiting the dissolution of Congress at any time, even during national crises.

**Table 4.4 The Evolution of Anti-Terrorism Legislation in Peru, 1981-1994**

<sup>109</sup> In 2003, the Constitutional Court (equivalent to the US Supreme Court) declared unconstitutional Law 25659. Those convicted in military courts or in faceless tribunals, whether under civilian or military jurisdiction, would be granted a new trial.

## CHAPTER 5

### WARTIME SEXUAL VIOLENCE IN PERU: AN ANALYSIS OF SUB-NATIONAL VARIATION

#### **Introduction**

Contributing to our collective understanding of the causes of wartime sexual violence, this chapter focuses on state-perpetrated abuses during the Peruvian civil war. Specifically, it asks “why is sexual violence more frequent in some areas and at some points in time than in others?” I argue that sexual violence was an important component of the military’s strategy to eradicate the Shining Path insurgency. It was used alongside other forms of political repression during periods of irregular warfare to frustrate the rebels’ mobilization efforts and undermine their military capabilities. The results of a negative binomial regression analysis support this argument and demonstrate that there exists a curvilinear relationship between rebel activity and the state’s use of sexual violence.

The chapter is organized as follows. It begins with a brief review of the data used in the analysis and provides general descriptive statistics on patterns of human rights abuse during the war. It then discusses the appropriateness of negative binomial regression to analyze the count data. It concludes by presenting the results of the model and providing a discussion of the implications of the findings.

#### **Data Collection and Procedures**

#### **Dependent Variable**

The dependent variable in the analysis is the reported number of sexual violations perpetrated by the state armed forces. Sexual violence is defined as any act of a sexual

nature aimed at attacking the victim's sexual and/or gender identity. As discussed in Chapter 3, I recorded information on eight forms of sexual violence: rape, gang rape, sexual torture, sexual mutilation, sexual humiliation, sexual coercion, forced abortion, and other unspecified types of sexual violence.

Sexual violence comprised about 5.39 percent of all state-perpetrated human rights violations during the Peruvian civil war.<sup>110</sup> There are 656 cases of sexual violence by state armed forces recorded in the database.<sup>111</sup> While I employ a broader definition of sexual violence than most scholars (Cohen 2010, Green 2006, Wood 2006 and 2009), it is important to note that the vast majority of these cases (almost 70 percent) include at least one type of sexual violence that is recognized by the International Criminal Court as a war crime and/or crime against humanity.<sup>112</sup> Moreover, the results presented below do not significantly change even when the dependent variable is restricted to the ICC's definition of sexual violence (see Table E.2).

The most frequent forms of sexual violence were rape and gang rape (42 percent), sexual humiliation (34 percent), and sexual torture (12 percent). Similar to the findings of others (Cohen 2010), approximately 30 percent of rapes committed during the war were gang rapes. Unlike other conflicts, such as in the former Yugoslavia, Rwanda or Guatemala, there is little evidence that women were either forcibly impregnated by their sexual attackers or forced to abort fetuses they were already carrying (see Figure 5.1 below).

---

<sup>110</sup> Sexual violence comprises 5 percent of all state violence, when battle-related deaths and injuries and massacres are included. Because I theorize sexual violence as a weapon of war during periods of irregular, counterinsurgency warfare, I exclude these forms of violence from the analysis.

<sup>111</sup> Because individual victims may suffer more than one type of sexual violation during any given act of sexual violence, the total number of sexual violations is 804.

<sup>112</sup> For a detailed discussion of the methodological choice to define sexual violence broadly, please see Leiby 2009b.



Data on other forms of state-perpetrated repression (*state-perpetrated non-sexual violence*) follow similar collection procedures and come from the same victims' and witnesses' testimonies as sexual violence. Data was gathered on six forms of non-sexual political violence: detention, forced disappearance, extrajudicial execution, forced recruitment, kidnapping, and torture. More than 12,181 such violations were recorded. It is interesting to note that despite the emphasis in the conflict studies literature on lethal acts of violence, less than half of the violations recorded resulted in the death (or presumed death in the case of disappearances) of the victim (see Figure 5.2 below).<sup>115</sup> The most frequent forms of non-lethal state violence were arbitrary detention and kidnapping (22 and 14 percent, respectively) and torture (18 percent).

Most violence occurred between 1984 and 1989 in the central Andean region of Peru (see Figures 6.3 and 6.4 below).<sup>116</sup> By far, the most affected department was Ayacucho, where the Shining Path originated and began their revolutionary war against

---

function of its training, leadership, intelligence and communications system) are not available at the department level over time.

<sup>114</sup> To distinguish the effects of active military combat and operations from military presence, I would like to include a measure of internal deployment and troops assignments for each branch of the armed forces and national police. However, these data are not available at the sub-national (department) level. Most military records in Peru during this period are still classified and inaccessible to the public. While the U.S. Defense Intelligence Agency tracks information on troop movements and deployment of foreign militaries, they have not responded to multiple Freedom of Information Act (FOIA) requests made by the National Security Archives in Washington, D.C (personal communication with Tamara Feinstein of the National Security Archives, 01/24/11). So even though the data exist, they are not currently available to researchers.

<sup>115</sup> It is important to note that while 62 percent of victims in the database were killed, this seldom occurred in isolation of other human rights violations. As a result, the majority of violations observed are non-lethal.

<sup>116</sup> This finding could be biased if most data collection and programmatic efforts by the CVR were focused in the central sierra region of the country. While the CVR established at least one office in every department in the country (CVR 2003

<http://www.cverdad.org.pe/ingles/lacomision/sregionales/mapasedes.php>), data indicate that 31 percent of all testimonies were collected in Ayacucho, 14 percent in Huánuco, 14 percent in Junín and Pasco (combined), 8 percent in Apurímac, 7 percent in Huancavelica, 7 percent in Lima, 4 percent in San Martín, 3 percent in Puno, 2 percent in Cusco, 2 percent in Ucayali and a combined 8 percent in the remaining departments (CVR 2003). The only departments to have more than one CVR office – Cusco and Ucayali – accounted for only 4 percent of all the testimonies collected by the CVR, perhaps indicating that access is not the only factor to determine the number of human rights violations denounced before the truth commission.



the state. Also impacted by the violence were the departments of Junín, Huánuco, and Huancavelica, each with significant indigenous populations.

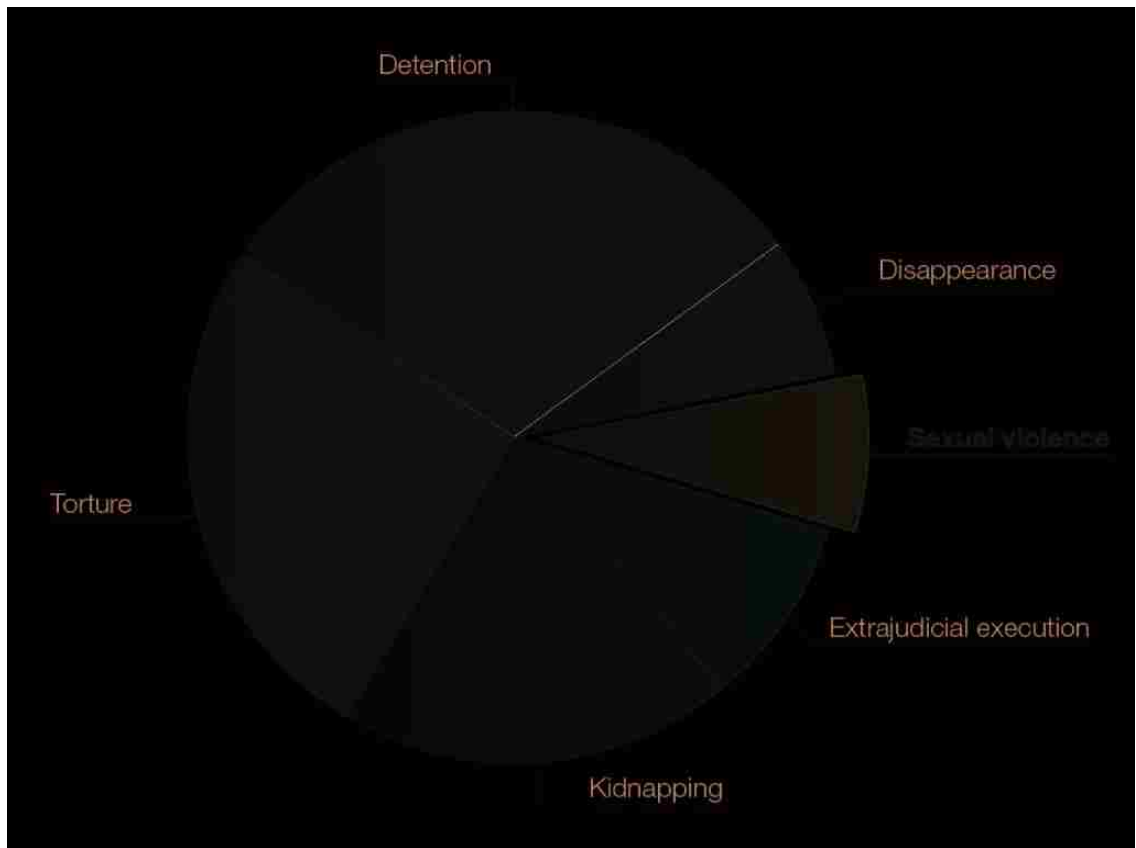

**Figure 5.2 State Repression during the Peruvian Civil War, 1980- 2000**

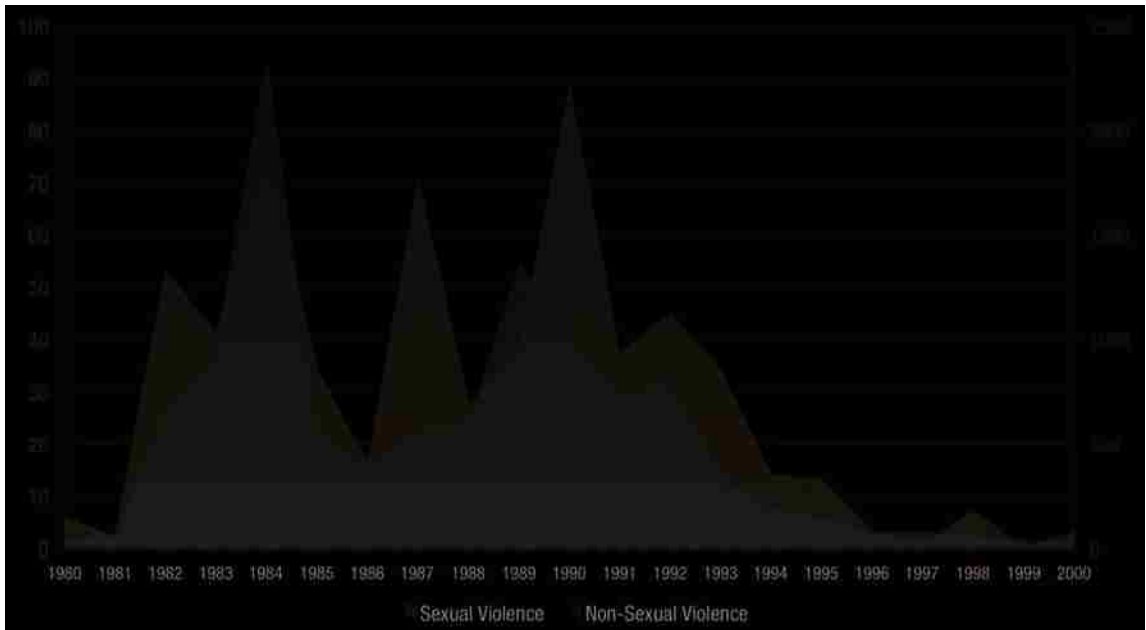

**Figure 5.3 State-Perpetrated Sexual and Other Forms of Political Violence during the Peruvian Civil War, 1980-2000**



departments in Peru, they alone cannot account for the observed sub-national variation in wartime sexual violence.

To approximate values and ideas that support unequal gender relations in society, data on the status of women in Peru is included in the model. These data come from Peruvian census records between 1961 and 2007 and the World Bank databanks on population and gender statistics.<sup>118</sup> The measures of inequality between women and men included in the study are: the ratio of women to men who can read and write, the ratio of women to men who are economically active, and the percentage of women who have five or more children. Complete definitions and measurement methods may be found in Appendix D. All of these measures are recorded at the department level (the sub-national political geographic unit equivalent to a U.S. state). Data on the status of women, like many data used in the social sciences, are notoriously incomplete. Recordkeeping was particularly difficult during the civil war (1980-2000). During this period, the government conducted only two censuses. The resultant missing data problem makes systematic analysis over time and across space difficult and subject to bias.<sup>119</sup> To address this, I use linear interpolation to estimate values for missing data points (at  $t_2$ ) based on

---

<sup>118</sup> During this period, there were six national censuses – one in 1961, 1973, 1981, 1993, 2005, and 2007. The World Bank databanks may be accessed through their website at <http://databank.worldbank.org>. These data were only used to fill in missing data points in the Peruvian censuses.

<sup>119</sup> The availability and comparability of data on the status of women is further complicated by the fact that the *Instituto Nacional de Estadística e Informática* (INEI, National Institute of Statistics and Information) did not employ the same standardized measures for every national census. Some years offer more complete information on the status of women than others. That the 1993 census includes data on the rate of contraceptive use among married women and the percentage of households that are headed by women does not guarantee that similar data will be included in subsequent surveys. In fact, these data are not reported for either the 2005 or 2007 censuses. Moreover, the INEI sometimes changes the definitions and measurement of indicators. For example, in 1961 economic activity is measured for men and women 6 years and older; in 1981 it is measured for men and women 15 years and older. If I was unable to standardize the measures over time, they were not included in the analysis.

known values of the same variable at  $t_1$  and  $t_3$ , a method commonly employed by demographers (Shryock, et al. 1980).<sup>120</sup>

I also control for department population size, as the frequency of state-perpetrated sexual violence is likely to be higher simply because more people reside there. These data come from Peruvian census records between 1961 and 2007. Again, I used linear interpolation to estimate and replace missing data points because the Peruvian government only conducted five censuses during this period. Table 5.1 provides summary statistics for each of the variables included in the model.

Variable	N <sup>121</sup>	Mean	Standard Deviation	Minimum	Maximum
State SV	504	1.28	4.80	0	65
Contestation	408	0.89	3.50	0	43
Unilateral MRTA Activity	408	0.63	4.60	0	67
Unilateral SL Activity	408	3.51	10.33	0	102
Unilateral Unspec. Subv. Activity	408	3.64	12.28	0	114
Population	575	858603	1266437	21300	9322088
Gender Inequality: Literacy	573	-15.40	9.34	-40.39	-0.77
Gender Inequality: Economic Activity	573	-45.25	8.93	-79.6	-17.38
Percentage of Women with >5 Children	573	23.64	6.00	6.4	36.83
State-Perpetrated Non-Sexual Violence	504	14.78	62.21	0	1040

Table 5.1 Summary Statistics of Variables

Table 5.2 shows the correlations between the variables included in the model.

There is some support for the hypotheses outlined in Chapter 2.

<sup>120</sup> This approach is preferable to dropping all observations with missing data or substituting values with the mean. The first method would severely constrain the scope of the dataset, making analysis difficult, if not impossible. The second approach would distort the variance of the variable, which could result in biased estimates.

<sup>121</sup> The unit of analysis in the model is the department-year. As there are 24 departments in Peru and the civil war spanned 20 years, for any given variable there are 504 potential observations. The FBIS reports were only available until 1996, limiting the number of department-year observations to 408 for each of the theoretical variables.

	State SV	Battles	Unilateral MRTA Activity	Unilateral SL Activity	Unilateral Unspec. Subv. Activity	State Non-Sexual Violence	Population	Gender Inequality: Literacy	Gender Inequality: Economic Activity	Percentage of Women with >5 Children
State SV	1.00									
Contestation	0.68	1.00								
Unilateral MRTA Activity	0.10	0.09	1.00							
Unilateral SL Activity	0.59	0.70	0.52	1.00						
Unilateral Unspec. Subv. Activity	0.33	0.42	0.55	0.57	1.00					
State-Perpetrated Non-Sexual Violence	0.85	0.80	0.07	0.65	0.37	1.00				
Population	0.15	0.06	0.48	0.38	0.59	0.13	1.00			
Gender Inequality: Literacy	-0.22	-0.24	0.13	-0.16	0.03	-0.20	0.20	1.00		
Gender Inequality: Economic Activity	0.03	0.05	0.06	0.08	0.16	0.03	0.14	-0.20	1.00	
Percentage of Women with >5 Children	0.13	0.17	-0.21	0.00	-0.15	0.12	-0.43	-0.70	0.08	1.00

Table 5.2 Correlation Matrix

## Methods

The analysis explains the variation in the frequency of wartime sexual violence across departments within Peru using the independent variables specified above. The unit of analysis is the department-year. The data set contains information on sexual violence and other human rights violations, the status of women, and state and non-state armed groups' military activity for 24 departments between 1980-1996.<sup>122</sup>

The dependent variable in this model is a frequency count – the number of reported sexual violations. The dependent variable can only take on positive values of 0 or above. Estimation techniques, such as OLS regression that are designed for continuous data are inappropriate for modeling count data (Hubbard nd, King 1989, Wang, et al. 1993) and have resulted in severe heteroskedasticity, bias and nonsensical results (King 1988). Poisson regression is often used to model event counts. In this case, however, the dependent variable is not normally distributed and is overdispersed. The observed level of sexual violence at time  $t + 1$  is not independent of the observed level of sexual violence at time  $t$  (an assumption of the Poisson model). In a Poisson distribution, the mean and the variance of the variable (in this case, the number of sexual assaults) are the same. When the variance is greater than the mean, the variable is said to be overdispersed. In this case, the variance in the frequency of sexual violence (28.02) is almost twenty times greater than the mean (1.55). Because the dependent variable is not normally distributed and is overdispersed, use of the Poisson model is rejected in favor of the negative binomial model.<sup>123</sup>

---

<sup>122</sup> Data on the independent variables are only available from FBIS reports until 1996.

<sup>123</sup> I also used a zero-inflated negative binomial regression model, which I suspected would be a better fit given that approximately 70 percent of the observations of the dependent variable are zero. However, I do not report the results of this model as it was not a better fit than the simpler, negative binomial regression

As discussed in Chapter 2, the relationship between rebel activity and the state's use of sexual violence is believed to be curvilinear. In other words, at low to moderate levels of rebel power and activity, the state will take counterinsurgency measures to respond to the moderate and increasing threat to national security. This period will be characterized by the state's frequent use of sexual violence, torture, arbitrary detention, and interrogation to (1) gain information on the identity of members of subversive organizations and the location of rebel bases and weapons caches; and (2) punish and terrorize members of subversive organizations and their potential recruits in order to neutralize them. However, as the threat to the state increases, as the rebels become stronger, better equipped and more effective in their offensive capabilities, the state will engage less in acts of non-lethal repression, focusing instead on direct combat with the rebels. The general relationship expected between state-perpetrated sexual violence and rebel activity is shown in Figure 2.1 in Chapter 2.

The simplest way to examine a nonlinear relationship is to fit a quadratic model:

$$Y = \beta_0 + \beta_1 X_1 + \beta_2 X_2 + \beta_3 X_2^2$$

Because the expected relationship between rebel activity and the state's use of sexual violence is curvilinear, I include squared terms for each of the three independent variables measuring rebel operations and attacks (uni\_MRТА, uni\_SL, uni\_unksbv and their corresponding squared terms, uni\_MRТА<sup>2</sup>, uni\_SL<sup>2</sup>, uni\_unksbv<sup>2</sup>). The interpretation of the quadratic term,  $X^2$ , depends on whether the linear term,  $X$ , is positive or negative. If the quadratic term is positive, the net effect is a greater than linear increase. If the quadratic term is negative, it exerts a downward force on the equation.

---

model. The goodness of fit of the models was compared using the Vuong test (UCLA Academic Technology Services, Statistical Consulting Group nd). An insignificant z-test indicates that the zero-inflated model is not an improvement over the ordinary negative binomial regression model.



Figure 5.5 below illustrates how “defaulting to linearity might be a problematic method of data analysis” (Keele 2008, 5). It shows both the plotted regression line when the quadratic term is omitted from the right hand side of the equation as well as the true quadratic function. The researcher interpreting these results would incorrectly conclude that  $X$  is not related to  $Y$  given that the regression line is virtually flat, when in fact Figure 6 shows that there is a strong relationship between  $X$  and  $Y$ ; it is simply nonlinear in form (Keele 2008).

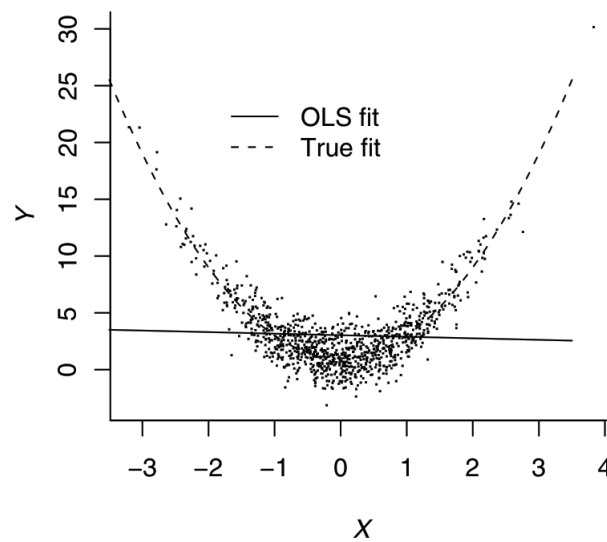

**Figure 5.5 A Linear Fit and the True Quadratic Relationship with Simulated Data (from Keele 2008)**

Similarly, failing to include the squared terms of the variables measuring rebel activity ( $uni\_MRTA$ ,  $uni\_SL$ ,  $uni\_unsubv$ ) could lead the researcher to conclude incorrectly that there is no relationship between rebel power and sexual violence (see results in Table E.1 in Appendix E).

## Findings

Results from the negative binomial regression model are presented in Table 5.3.<sup>124</sup> The results show support for the strategic model of state-perpetrated wartime sexual violence. There are a few interesting and somewhat counterintuitive results, however, that require further discussion.

The results in Table 5.3 confirm the hypothesis that sexual violence and other forms of political violence generally correlate over time and across space. The results show that acts of state repression, such as torture and kidnapping (*political violence*) are a significant predictor of state-perpetrated sexual violence ( $z=6.28$ ,  $p<0.001$ ). In other words, the state commits sexual violence when it is also engaged in other forms of violence, which supports the previous finding that victims of sexual violence experience many violations of their human rights and are rarely targeted for sexual violence alone. The finding from the negative binomial regression provides additional support for the hypothesis that sexual violence will correlate over time and across space with other forms of political violence.

The relationship between unilateral operations and attacks by the Shining Path and the state's use of sexual violence is indeed curvilinear, and follows an upside down U trend. The variable *uni\_SL* is significant and positively correlated with state-perpetrated sexual violence ( $z=3.24$ ,  $p=0.001$ ). The squared term of the same variable, *uni\_SL2*, is significant and negatively correlated with state-perpetrated sexual violence ( $z=-3.34$ ,  $p=0.001$ ). Figure 5.6 illustrates the predicted number of sexual violations given observed levels of Shining Path activity.

---

<sup>124</sup> Any variable with a Z score above 1.96 is considered significant at the conventional  $p<0.05$  level, and has been highlighted in the table. Note the overdispersion parameter ( $\alpha$ ); it is significantly different from zero, thus confirming the appropriateness of the negative binomial model.

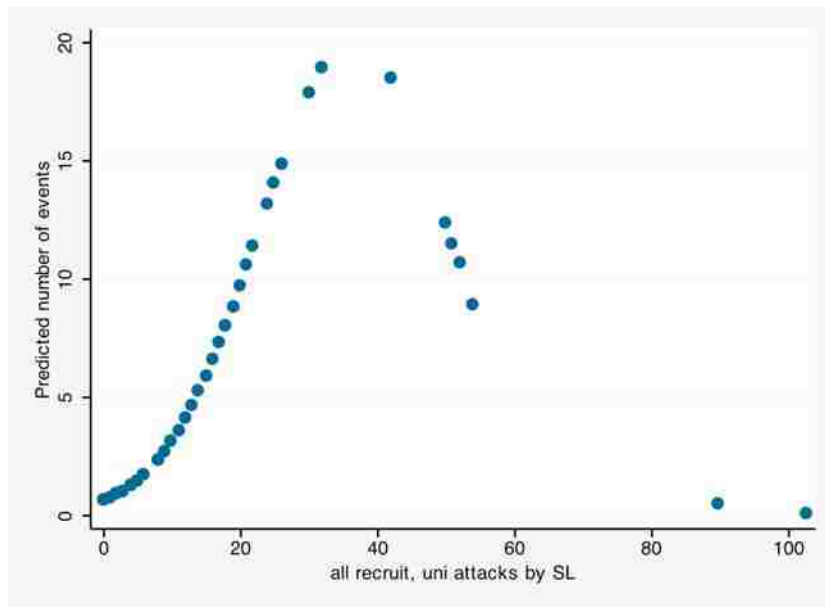

**Figure 5.6 Predicted Frequency of State-Perpetrated Sexual Violence Given Observed Frequency of Shining Path Activity**

Unilateral attacks and operations by the MRTA do not appear to have the same impact on the state’s use of sexual violence as do such activities by the Shining Path. The variable uni\_MRTA is negatively associated with sexual violence, while the variable uni\_MRTA2 (the squared term) is positively associated with sexual violence, both significant at the  $p < 0.05$  level. This suggests that at both very low and very high rates of activity by the MRTA, the state engages in more sexual violence. When the MRTA is moderately active, the state engages in less sexual violence. However, including only the two variables measuring MRTA activity (uni\_MRTA and uni\_MRTA2) in the model and controlling for population size, any statistically significant relationship disappears. There are only 36 department-years (out of 408) with any recorded MRTA activity. Moreover, there is not a great deal of variation in the level of MRTA activity across department years, despite significant variation in the frequency of sexual violence.

There are a few department-years where the MRTA is active, but at very low levels, and where the state perpetrates many acts of sexual violence, accounting for the

positive integer on the variable uni\_MRTA. There are also numerous department-years where the MRTA is active and growing their presence, during which times the level of sexual violence is low; this drives the negative integer on the variable uni\_MRTA2. Restricting the model to only examine the relationship between MRTA activity and state sexual violence reveals that there is no statistically significant relationship.

Moreover, the MRTA concentrated their operations in the capital, Lima. Out of 257 recorded attacks and operations carried out by the MRTA, 208 (81 percent) occurred in Lima. As I will discuss below, there are reasons to suspect that the state will behave differently in the densely populated capital city than in other, more remote areas of the country.

The theory also expected that the state would engage in less sexual violence as the relative power of the rebel group grew, forcing the state to focus its response on direct combat and lethal violence. As the number of battles between the state and rebels increase, the level of state-perpetrated sexual violence should decrease, as all effort and resources must be dedicated to combat operations. The results below show that there is no significant relationship between state-perpetrated sexual violence and battles between the state and non-state armed groups. Again, this could be because there are relatively few department-years where battles were reported (less than 25 percent).

<b>Negative binomial regression</b>					
				<b>Number of Observations= 407</b>	
				<b>LR chi2(12)= 155.46</b>	
				<b>Prob &gt; chi2= 0.0000</b>	
				<b>Pseudo R2= 0.1592</b>	
		<b>Coef.</b>	<b>Std. Err.</b>	<b>Z</b>	<b>P&gt; z </b>
<b>Conflict Variables</b>	Contestation	.0117151	.082821	0.14	0.888
	Unilateral MRTA Activity	-.2301496	.1059514	<b>-2.17*</b>	0.030
	Unilateral MRTA Activity <sup>2</sup>	.0076608	.0027697	<b>2.77**</b>	0.006
	Unilateral SL	.1362664	.0421069	<b>3.24***</b>	0.001

	Activity				
	Unilateral SL Activity <sup>2</sup>	-.0033424	.0009994	<b>-3.34***</b>	0.001
	Unilateral Unspec. Subv. Activity	-.0088744	.0321876	-0.28	-0.783
	Unilateral Unspec. Subv. Activity <sup>2</sup>	-.0001846	.0003828	-0.48	0.630
<b>Control Variables</b>	Population	3.71e-07	1.59e-07	<b>2.33*</b>	0.020
	Gender Inequality: Literacy	-.0185653	.0226863	-0.82	0.413
	Gender Inequality: Economic Activity	-.0334473	.0135271	<b>-2.47*</b>	0.013
	Percentage of Women with >5 Children	.0714779	.0464501	1.54	0.124
	State-Perpetrated Non-Sexual Violence	.0304707	.0048513	<b>6.28***</b>	0.000
	Constant	-5.363504	1.230085	<b>-4.36***</b>	0.000

**Table 5.3 Results, Negative Binomial Regression with Squared Terms ( $Y = \beta_0 + \beta_1 X_1 + \beta_2 X_1^2 + \dots$ )**

Controlling for the size of the population and the status of women, the negative binomial regression analysis provides some support for the theoretical proposition that the state engages in greater levels of sexual abuse during periods of counterinsurgency warfare.<sup>125</sup> During such periods of conflict, the state will engage in particular forms of repression, namely, sexual violence, torture, political assassination, and arbitrary detention. However, as the Shining Path became increasingly active, in turn, presenting a clear and present danger to the continued existence of the state, the war moved onto the battlefield. The state's resources – soldiers, weapons and time – became more focused on direct combat operations and moved away from the types of political repression found during periods of low intensity warfare.

To examine the robustness of the findings, I ran the same model, restricting the dependent variable to those sexual violations that are codified as war crimes by the ICC.

The findings are presented in Appendix E (Table E.2). The direction and statistical

<sup>125</sup> Sexual violence increases as the size of the population increases ( $z=2.33$ ,  $p<0.05$ ). This finding is consistent across different specifications of the model.

significance between each of the theoretical variables and the prevalence of state-perpetrated sexual violence remains the same.<sup>126</sup> I also ran the model, excluding significant outliers (department- years in which the number of unilateral Shining Path attacks and operations far exceed the mean). The results of this analysis, and their impact on the overall finding of the model, are discussed below.

### **Discussion of Outliers and Controls**

To subject the finding that sexual violence increases at low to moderate levels of Shining Path activity, but then decreases as the relative strength of the rebels forces the state to engage solely (or predominantly) in direct combat, I ran the same model excluding significant outliers. While the mean frequency of Shining Path attacks and operations is 3.51 in any given department-year, the frequency ranges from zero (no recorded Shining Path activity in a given department, in a given year) to 102 across the dataset.<sup>127</sup> The substantial concentration of Shining Path activity in Lima in 1986 (95 recorded events) and Ayacucho in 1984 (102 recorded events) could be driving the reported results. To test this possibility, I ran the same negative binomial model, excluding these two cases.

The results of the restricted model, where  $uni\_SL < 60$  are reported in Table 5.4 and show that the model is sensitive to the exclusion of these cases. Focusing on the relationship between unilateral attacks and operations by the Shining Path and state-perpetrated sexual violence, we can see that although the same basic curvilinear and

---

<sup>126</sup> However, the difference between the percentage of men and the percentage of women who are economically active is no longer a significant predictor of the prevalence of state-perpetrated sexual violence. It is not clear why this is the case.

<sup>127</sup> The mean reported number of attacks and operations by the Shining Path is low because of the high frequency of zeros; there are 258 (63 percent) department-years in which there was no recorded Shining Path activity. If we exclude department-years where the Shining Path was not active, the mean jumps to 9.55 attacks or operations per department-year.

negative relationship exists, the squared term (uni\_SL2) is no longer significant at the conventional  $p < 0.05$  level.

<b>Negative binomial regression</b>					
					<b>Number of Observations= 405</b>
					<b>LR chi2(12)= 154.52</b>
					<b>Prob &gt; chi2= 0.000</b>
					<b>Pseudo R2= 0.1628</b>
		<b>Coef.</b>	<b>Std. Err.</b>	<b>Z</b>	<b>P&gt; z </b>
<b>Conflict Variables</b>	Contestation	-.0902014	.0808187	-1.12	0.264
	Unilateral MRTA Activity	-.0500905	.1400981	-0.36	0.721
	Unilateral MRTA Activity <sup>2</sup>	.0016938	.0038527	0.44	0.660
	Unilateral SL Activity	.0872489	.0420504	<b>2.07*</b>	0.038
	Unilateral SL Activity <sup>2</sup>	-.001534	.0009918	-1.55	0.122
	Unilateral Unspec. Subv. Activity	-.0044459	.0322285	-0.14	0.890
	Unilateral Unspec. Subv. Activity <sup>2</sup>	-.0002449	.0003606	-0.68	0.497
<b>Control Variables</b>	Population	3.43e-07	1.55e-07	<b>2.22*</b>	0.027
	Gender Inequality: Literacy	-.0136077	.0226243	-0.60	0.548
	Gender Inequality: Economic Activity	-.0302972	.013852	<b>-2.19**</b>	0.029
	Percentage of Women with >5 Children	.0754966	.0465274	1.62	0.105
	State-Perpetrated Non-Sexual Violence	.0386233	.0053501	<b>7.22</b>	0.000
	Constant	-5.307101	1.249551	<b>-4.25***</b>	0.000

**Table 5.4 Results, Negative Binomial Regression Dropping Significant Outliers (where uni\_SL <60)**

However, the case of Ayacucho in 1984 actually supports the theoretical claim that sexual violence is a component of the state's counterinsurgency strategy at levels of low intensity conflict and *not* during periods of high intensity conflict and combat. In 1984 in Ayacucho, the Shining Path engaged in 102 unilateral operations and assaults, presenting a significant threat to state control and security in the area. To confront this threat, the state carried out 47 unilateral operations, mostly directed towards population control and identifying members of subversive organizations. Additionally, security

forces (sometimes in collaboration with community self-defense militias) directly battled the Shining Path on 35 separate occasions. This suggests, that much of the armed force's resources and efforts were devoted to direct combat, leaving little opportunity or capability to perpetrate sexual violence against their political "enemies."

Lima presents itself as an outlier in that the predicted level of sexual violence is low given the level of Shining Path activity in 1986 and the low level of direct combat. There are a number of reasons that we would expect the state armed forces to not engage in active combat in the capital, even if there was a significant threat presented by an active rebel group. Moreover, it could be argued that there are simply more opportunities and strategic targets for rebel groups to attack in Lima than in the highlands. To gauge the relative severity or intensity of these attacks, I compared the number of reported casualties associated with each event. The total of all reported injuries and deaths resulting from the 95 unilateral attacks and operations perpetrated by the Shining Path in Lima in 1986 was 52. The total of all reported injuries and deaths resulting from the 102 unilateral attacks and operations perpetrated by the Shining Path in Ayacucho in 1984 was 897. Moreover, of the 95 attacks committed by the Shining Path in Lima in 1986, only 8 (8 percent) were against military targets (police stations, military bases or barracks). More commonly, the SL attacked electrical towers, power plants and commercial centers (such as banks, manufacturing factories and private businesses) to disrupt the economic production of the capital, foreign embassies, and the offices and homes of members of the political opposition, which included any established political party or organization that was not directly associated with the Shining Path (members of APRA and the IU were targeted most often).



Compared to their operations in Lima in 1986, the Shining Path more often attacked military targets in Ayacucho in 1984. At the time, 20 percent of all Shining Path operations in Ayacucho were against police stations and military barracks. From the strategic standpoint of the SL, this is not surprising given that such military posts are remote and probably less secure than those located in the capital, making them easy targets if one wants to inflict casualties on the Peruvian armed forces and/or capture additional weapons and ammunition. Other sites of SL violence in Ayacucho in 1986 included: mines (where bomb-making materials could be found), commercial centers, electrical towers and radio stations, government buildings and private residences or villages where civilians would be attacked for their refusal to join the rebel front or for collaborating with the state. I conclude, therefore, that the relative threat to the state posed by the Shining Path was greater in Ayacucho in 1984 than in Lima in 1986, forcing the state to forgo counterinsurgency warfare tactics (including sexual violence) in favor of direct armed combat.

All of this is to suggest that the two proposed outlying cases – Ayacucho in 1984 with 102 unilateral attacks by the Shining Path and Lima in 1986 with 95 unilateral attacks by the Shining Path – do not contradict the basic premises of the theory. The results of this analysis, that sexual violence increases as the relative power and activity of rebel organizations increase to a critical threshold, after which increased rebel activity actually depresses the frequency of sexual violence, should be seen as preliminary and requiring confirmation from additional cases and data. Each predicted count of state-perpetrated sexual violence (illustrated in Figure 5.6) has an associated confidence interval around it. The more observations at a particular level of rebel activity, the more

predicted counts of sexual violence will be generated, and the greater the confidence we can have that these predicted values are sound.

Because the feminist literature on sexual violence generates conflicting hypotheses regarding the status of women, indicators of gender inequality in Peru are included as control variables as opposed to key explanatory variables in the model. The results presented in Tables 5.3 and 5.4 show that the effect of gender inequality is inconsistent. The only measure of the status of women that is significantly related to the state's use of sexual violence is the gap between rates of male and female economic activity ( $z=-2.47$ ,  $p<0.01$ ). However, the sign of the coefficient is in the opposite direction as that expected by the feminist literature. The finding suggests that greater levels of gender inequality in economic activity are correlated with *lower* levels of sexual violence.

However, there is reason to believe that the systematic disenfranchisement of women common in patriarchal societies cannot easily be quantified. That women are marginalized in Peruvian society, that the armed forces represent institutions of hostile disregard and distrust of femininity must be considered in any causal story about the state's use of sexual violence during war. Sexual violence will only enter the state's repertoire of counterinsurgency tactics if the preexisting norms that govern social relations denigrate women and view women and femininity as weak. The importance of these norms becomes clear when we examine the language of perpetrators during the commission of sexual assaults. The following examples illustrate the systematic devaluation of women and all things feminine:

“Oye prostituta, ¿Cuántos te tiras tú al día? Cuántos te montan, prostituta?”

(CVR Testimony 700020). In this case, the perpetrators simultaneously give the woman agency by asking her how many men she “throws down with” everyday, and then take it away by asking her how many men “mount” or “take” her. The perpetrators justify their attack against her by calling her a prostitute; suggesting she has had many sexual partners brands her as available, someone with no honor and no right to refuse them.

“Oye machorra!” (CVR 2003, 39). *Machorra* literally means to be infertile. It is usually used in the context of describing an animal, such as a cow that no longer produces milk or can no longer breed successfully. The connotation is very offensive when directed at women. Particularly in patriarchal societies where a woman’s value is inextricably linked to her fertility and role as a mother, an “old, dried up” woman is seen as worthless.

There is no other way to understand these debasing utterances without reference to the devaluation of women that undergirds all social, political and economic interactions in a fundamentally patriarchal society.

These same patriarchal processes and values can be applied to understanding the use of sexual violence against men during conflict. To rape a man is to make him female and thus powerless. Sexual violence against men challenges their masculinity, their virility and their heterosexuality. In many societies, *any* sexual contact between two men is considered to be proof of one’s homosexuality, regardless of the use of force or the absence of consent (Sivakumaran 2005).<sup>128</sup> Although rarely reported in Peru, the same

---

<sup>128</sup> Paradoxically, male rape simultaneously calls into question the masculinity and heterosexuality of the victim, while re-asserting that of the perpetrator.

dynamics work when the perpetrator of the sexual assault is a woman. Consider the following case:

On the morning of March 6, 1988 Leoncio, his partner Katrina, and his brother Lucero left to go to the market. On their way home, a car pulled up alongside of them and asked Leoncio what his name was. All of a sudden, five men jumped out of the car and began to beat him with the butts of their guns until he collapsed on the ground. They grabbed him, blindfolded him and took him to DINCOTE, where he was detained for 15 days. He was tortured – beaten, deprived food and water. They submerged his head in a bucket of urine while interrogating him about recent attacks, the location of arms caches and the names of “other terrorists.” He was then stripped and hung naked with his hands behind his back. The DINCOTE officers brought in two policewomen to humiliate Leoncio. The policewomen approached him, pulled on his penis and laughed, saying “look, at this poor fool; it’s so tiny” (CVR Testimony 720038, author translation). For the victim, being naked and subdued in front of two women in positions of authority reinforces his own powerlessness in the situation and highlights his weakness and vulnerability. The women’s physical and verbal attacks further add to his humiliation and emasculation. While there is not evidence of a statistically significant, positive, linear relationship between the gender inequality and the level of sexual violence perpetrated by armed forces, qualitative data suggests that wartime sexual violence is, indeed, *gender*-based violence.

## **Conclusion**

Negative binomial regression is used to examine the sub-national variation in the frequency of sexual violence. The results of the model show a curvilinear relationship

between the prevalence of sexual violence and the severity of the threat to national security presented by armed opposition groups. At low to moderate levels of rebel activity, the state will engage in counterinsurgency measures, including the use of repressive instruments such as sexual violence, designed to frustrate the opposition's mobilization efforts and undermine their military capabilities. However, once the rebels are established and able to engage in numerous, coordinated attacks, the state must shift its military strategy and focus its resources on direct combat in order to defeat the opposition.

The findings described above should not be interpreted as *the* definitive account of wartime sexual violence in Peru. In fact, I contend that no such story exists. Rather, it is my intention and hope that these findings will be used by scholars as the starting point for more rigorous analysis of variation in the repertoires of violence that lead to a more complete understanding of its causes in war. In this vein, the next chapter examines the contextual patterns of state-perpetrated sexual violence.

## CHAPTER 6

### PRINCIPALS, AGENTS AND STATE-PERPETRATED SEXUAL VIOLENCE IN

#### PERU: AN ANALYSIS OF MICRO PATTERNS

*A new Iraq will also need a humane, well-supervised prison system. Under the dictator, prisons like Abu Ghraib were symbols of death and torture. That same prison became a symbol of disgraceful conduct by a few American troops who dishonored our country and disregarded our values.*

(speech by President George W. Bush at the Army War College in the aftermath of the prisoner abuse scandal, May 24, 2004).

#### Introduction

In the wake of reports and allegations of abuse, political and military leaders often reply that any violation of humanitarian law and the standards of war are the regrettable acts of a few soldiers. Such remarks were repeated by Presidents Belaúnde, García and Fujimori after media reports of military and police abuse in Peru.<sup>129</sup> This chapter tests the argument that sexual violence is unfortunate, but inevitable during the “chaos of war” when leaders cannot effectively monitor or control the self-interested behavior of their soldiers. That this is the prevailing conventional wisdom mandates that the opportunity model be given careful consideration and subjected to rigorous empirical testing. By examining the patterns of perpetration of sexual and other human rights abuses, scholars can evaluate the plausibility of leaders’ claims that they had no knowledge of, did not encourage, and strictly prohibited illegal acts of violence by their militaries.

I find that the profile of sexual violence victims is statistically different from that of other human rights violations. In Peru, victims of sexual violence are both male and

---

<sup>129</sup> In 1985, President García proclaimed the massacre of more than 400 political prisoners by soldiers and police officers to be the “excesses of a few criminals.” Similarly, in response to allegations of the army’s involvement in the extrajudicial execution of 28 civilians in Cayara, Ayacucho in 1988, President García stated that the “errors by certain individuals would not affect the integrity of the military as an institution” (NSA May 24, 1988. “Growing Indications of Army Summary Executions at Cayara”).

female, are more educated, are less likely to be members of rural indigenous communities, and are *not* members of the population to whom soldiers had the most access. Moreover, I find that the military command was present during and permitted a substantial proportion of these sexual assaults. This evidence demonstrates that opportunism may offer a partial, but ultimately incomplete, explanation of sexual violence during the Peruvian civil war.

### **Data and Methods**

Using data collected from the personal testimonies of victims and survivors of violence, I created a new dataset on political violence, including sexual violence, during the Peruvian civil war (1980-2002).<sup>130</sup> The dataset covers 12 forms of political violence: detention, forced disappearance, extrajudicial execution, battle-related death, injury, forced recruitment, kidnapping, torture, and sexual violence. I recorded information on eight forms of sexual violence: rape, gang rape, sexual torture, sexual mutilation, sexual humiliation, sexual coercion, forced abortion, and other unspecified types of sexual violence.

In the sections that follow, I examine the variation in the types, victims and perpetrators of sexual and other forms of political violence. I present descriptive statistics on where, when, and how these crimes are perpetrated. Then, using  $\chi^2$  goodness of fit tests, I identify the statistically significant differences between acts of sexual violence and other forms of human rights violations. The null hypothesis ( $H_0$ ) states that there is no difference between political and sexual violence. When using categorical data with multiple values,  $\chi^2$  goodness of fit tests will only tell you whether

---

<sup>130</sup> The Peruvian civil war ended in 2000, however, data until 2002 is included to capture the trends in violence in the immediate post-conflict period.

there is a significant difference between the two specified variables *overall*; it will not identify *which* of the categories is driving the result.

For example, if we wanted to determine if male professors earned more money than female professors (holding constant rank, seniority and field of study), we could use the  $\chi^2$  goodness of fit test to test the  $H_0$ : there is no difference in the salary of male and female professors. Often, income data is reported in intervals (below \$19,999, \$20,000-\$39,999, \$40,000-\$59,999, and so on). Conducting the  $\chi^2$  goodness of fit test using data on the gender of all professors at a university and their reported income levels will only tell us if there is an *overall* significant difference in male and female salaries. It is conceivable, however, that at higher levels of income (\$100,000+), there is a more pronounced gender gap. To identify *which* income categories are resulting in an overall finding of difference, we need to calculate the standardized residuals for each income category ( $R = (O - E)/\sqrt{E}$ ), where  $O$  is the observed value and  $E$  is the expected value (Calkins n.d.). When the standardized residual ( $R$ ) is greater than 2.00, the corresponding category (of income, for example) is considered a significant contributor to the overall observed difference between the two variables (gender of the professor and reported salary). In the analysis below, I reported the Pearson  $\chi^2$  value, the significance value ( $p$ ), and where appropriate, the residuals ( $R$ ) for the most influential categories.

### **Repertoires of State-Perpetrated Violence during the Peruvian Civil War**

There are 12,181 human rights violations recorded in the database. It is interesting to note that despite the emphasis in the conflict studies literature on lethal acts of violence, less than half of the violations recorded resulted in the death (or presumed



death in the case of disappearances) of the victim (see Figure 6.1 below).<sup>131</sup> The most frequent forms of violence were massacres (22 percent, respectively), kidnapping and detention (14 and 22 percent, respectively), and torture (18 percent). Like most civil wars in the 20<sup>th</sup> century, the data indicate that civilians were much more likely to be killed than armed combatants during the Peruvian civil war. Individuals who lost their life during the war, were much more likely to be murdered or killed in a massacre of unarmed persons than they were to die on the battlefield. In addition, those who died, on or off of the battlefield, were much more likely to die during collective acts of violence than in isolated or targeted attacks.

Most violence occurred between 1984 and 1989 in the central Andean region of Peru (see Figures 4 and 5 below).<sup>132</sup> By far, the most affected department was Ayacucho, where the Shining Path originated and began their revolutionary war against the state. Also impacted by the violence were the departments of Apurímac, Junín, Huánuco, each with significant indigenous populations. Geographically and qualitatively distinct from the violence of the mountainous terrain of the Andean sierra, is the violence that struck the coastal department of Lima. In the capital city, the Shining Path and the MRTA frequently attacked buildings that either directly or symbolically represented the traditional power base of the economic and political elite in Peru. Targets included:

---

<sup>131</sup> It is important to note that while 62 percent of victims in the database were killed, this seldom occurred in isolation of other human rights violations. As a result, the majority of violations observed are non-lethal.

<sup>132</sup> This finding could be biased if most data collection and programmatic efforts by the CVR were focused in the central sierra region of the country. While the CVR established at least one office in every department in the country (CVR 2003 <http://www.cverdad.org.pe/ingles/lacomision/sregionales/mapasedes.php>), data indicate that 31 percent of all testimonies were collected in Ayacucho, 14 percent in Huánuco, 14 percent in Junín and Pasco (combined), 8 percent in Apurímac, 7 percent in Huancavelica, 7 percent in Lima, 4 percent in San Martín, 3 percent in Puno, 2 percent in Cusco, 2 percent in Ucayali and a combined 8 percent in the remaining departments (CVR 2003). The only departments to have more than one CVR office – Cusco and Ucayali - accounted for only 4 percent of all the testimonies collected by the CVR, perhaps indicating that access is not the only factor to determine the number of human rights violations denounced before the truth commission.

foreign embassies and corporations, the private residences of political leaders, political party headquarters, particularly those of the *Alianza Popular Revolucionaria Americana* (American Revolutionary Popular Alliance, APRA), and commercial centers.

Responding to the “terrorist” threat, the state engaged in significant repression in the capital; more than 10 percent of all state violence was concentrated in Lima.

Beyond geography, important insights into the motivations and causes of violence can be drawn from the precise location and context in which it occurs. Most human rights violations occurred outside of state-run detention facilities (83 percent), in a public venue (62 percent) and were not committed in an attempt to obtain “actionable intelligence” on the opposition (93 percent). Among the most common sites of violence were community plazas or squares, streets, churches and schools, and markets. Often violence was perpetrated in front of an audience, with the explicit intent of terrorizing those present and forced to watch. In fact, the Shining Path would often gather the members of a community together before performing a *juicio popular* (mock trial) on someone accused of betraying the revolution.

As discussed in Chapter 6, sexual violence comprised about 5 percent of all state-perpetrated human rights violations during the Peruvian civil war. The most frequent forms of sexual violence were rape and gang rape (42 percent), sexual humiliation (34 percent), and sexual torture (12 percent) (see Figure 6.2 below). Although the frequency of sexual violence appears to generally correlate with the occurrence of other types of political violence over time (with the most violent period being between 1984-1989), there is a statistically significant difference in the timing of sexual and other types of violence (Pearson  $\chi^2(22) = 146.0312, p < 0.001$ ). Sexual violence was more frequent

than expected in 1982, 1987, 1990, 1993 and 2000. Given the magnitude of repression in 1984, the state perpetrated less sexual violence than expected (see Figure 5.3 in Chapter 5).<sup>133</sup>

The frequency of sexual violence varies significantly across presidential administrations (Pearson  $\chi^2(2) = 22.6540, p < 0.001$ ). Given the distribution of human rights violations across governments, the armed forces were significantly less likely to engage in sexual violence during the Belaúnde administration, but more likely to do so during the Fujimori administration. These differences coincide with the changes in the state's counterinsurgency strategy discussed in Chapter 5. In particular, the absence of a clear, unified counterinsurgency strategy during the Belaúnde government yielded the highest absolute levels of sexual and other forms of political violence during the war. More so than the following two governments, this period was marked by ambiguous chains of command and incomplete information, suggesting that state agents could have perpetrated sexual violence opportunistically. Fujimori, on the other hand, has been characterized as exercising absolute authority over his administration. Under his leadership, the military and counter-terrorism police forces focused their efforts on identifying and locating members of the Shining Path and gaining actionable intelligence from them that would ultimately lead to the "beheading" of the organization. During this period (from 1990-2000), the state armed forces used sexual violence strategically to interrogate, punish and deactivate members of the opposition.

---

<sup>133</sup> While in 2000 sexual violence was more frequent than predicted, the result is based on a relatively small number of observations, and thus should be interpreted with caution. Excluding sexual humiliation and coercion (violations not recognized by the ICC) from the analysis, sexual violence is more frequent than expected in 1980, 1987 and 1993 and is less frequent than expected in 1982, 1984 and 1989.

Sexual violence occurred in different departments than other forms of political violence (Pearson  $\chi^2(21) = 262.2307$ ,  $p < 0.001$ ). Sexual violence was most frequent in Ayacucho (31 percent), Apurímac (17 percent), Lima (15 percent), Huánuco (6 percent) and Huancavelica (6 percent). Given the rate at which other forms of political violence occur across the country, sexual violence was more frequent than predicted in Apurímac, Cusco, Lima, Pasco and Piura (see Figure 5.4 in Chapter 5).<sup>134</sup> Conversely, sexual violence was less frequent than expected in Ancash, Ayacucho, Huánuco and San Martín.

Unlike other forms of political violence, sexual violence was largely committed in private, away from watchful eyes (Pearson  $\chi^2(1) = 109.6581$ ,  $p < 0.001$ ). Most often, this occurred in the victim's home or in secluded natural environments, such as woods and mountains. More frequently than expected, sexual violence was perpetrated in state-run detention facilities (Pearson  $\chi^2(1) = 304.2567$ ,  $p < 0.001$ ). That sexual violence occurs more frequently in detention centers does not necessarily suggest that the violence was perpetrated for instrumental, group reasons, as following case illustrates.

Josefa was subjected to both instrumental or strategic violence as well as opportunistic violence. She was detained, along with her father, at DINCOTE (*Dirección Nacional Contra el Terrorismo*, Counter-Terrorist Directorate) on suspicion of membership in the *Movimiento Revolucionario Túpac Amaru* (MRTA, Túpac Amaru Revolutionary Movement). Officers threatened to rape her if her father did not collaborate with them and give them the names of other MRTA rebels. During interrogation sessions, conducted in the presence of commanding officers, Josefa was

---

<sup>134</sup> Sexual violence was also more frequent than expected in Lambayeque and Loreto, however, these findings are based on small N. Acts of sexual violence recognized by the ICC are more likely to occur in Cusco, Huancavelica, Lima, Loreto and Lambayeque (although the latter two are based on small N) and less likely to occur in Ancash, Pasco and San Martín (Pearson  $\chi^2(21) = 94.771$ ,  $p < 0.001$ ).

tortured. At night, however, an officer who had keys to the prisoners' cells would harass and sexually assault her, asking her what kind of panties she wore and if she had ever been with a *real* man before (CVR Testimony 100085, italics are mine).

When isolated, cases like the one above may occur for purely opportunistic, self-gratifying reasons. However, when there is a pattern of frequent excessive abuses, it suggests that leaders (at some level of the political-military hierarchy) know that such violence is taking place and *either* they cannot control their agents *or* they choose not to. Moreover, that sexual violence was more frequently perpetrated during interrogation sessions or attempts to coerce a confession from the target suggests that sexual violence often serves the state's security interests (Pearson  $\chi^2(1) = 27.6359, p < 0.001$ ).

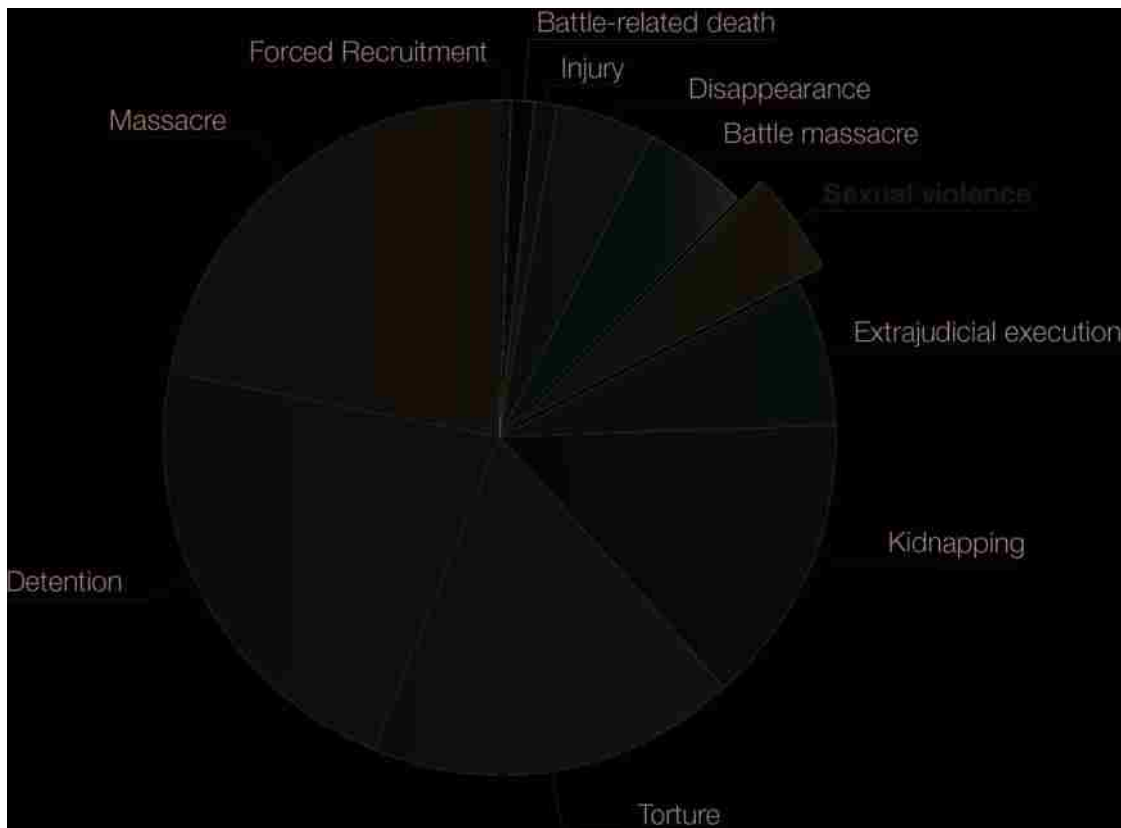

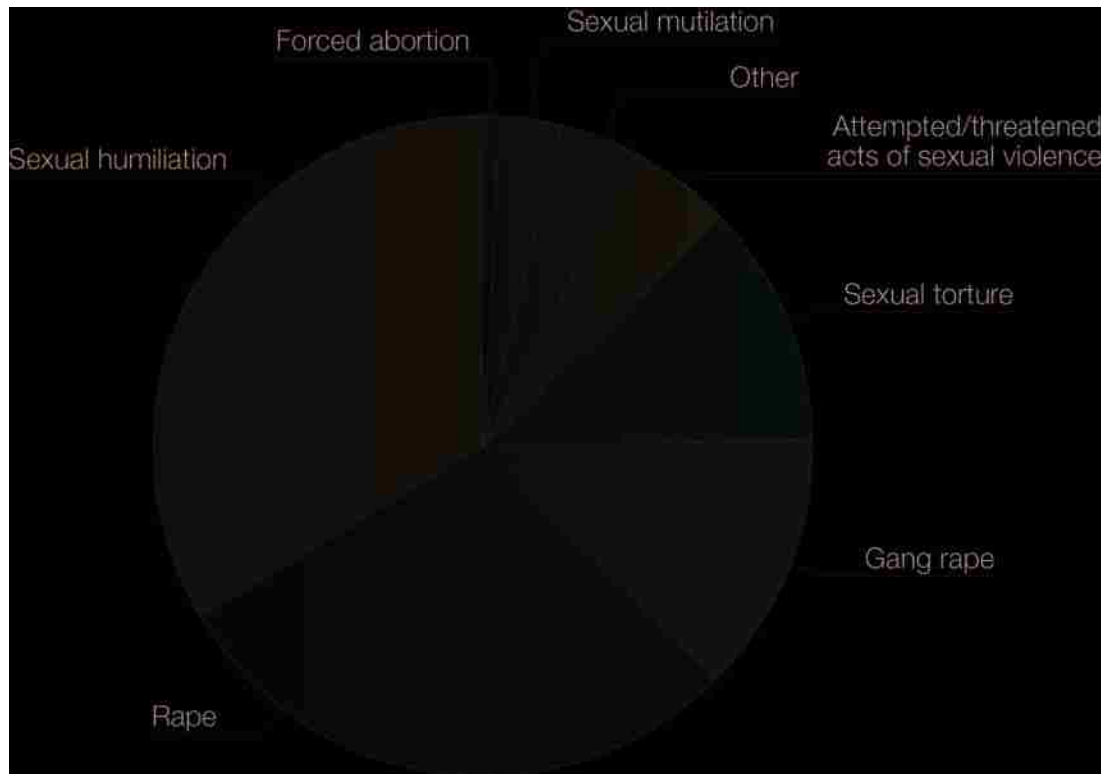

**Figures 6.1 and 6.2 State-Perpetrated Political and Sexual Violence in Peru, 1980-2002**

<b>ALL SEXUAL VIOLENCE (INCLUDING SEXUAL HUMILIATION AND COERCION)</b>	<b>SEXUAL VIOLENCE ACCORDING TO THE ICC</b>
656 cases of SV, 5.39% of state violence 804 individual sexual violations	438 cases of SV, 4% of state violence 485 individual sexual violations
<b>Types of Sexual Violence</b>	
Rape 29% Gang rape 13% Sexual humiliation 34% Sexual torture 12% Sexual mutilation 3% Sexual coercion 5% Forced abortion <1% Other 4%	Rape 49% Gang rape 21% Sexual torture 17% Sexual mutilation 7% Forced abortion <1% Other 6%
<b>Sexual Violence by Presidential Administration</b>	
Belaúnde government 27% García government 28% Fujimori government 37%	Belaúnde government 28% García government 28% Fujimori government 36%
<b>Sexual Violence by Department</b>	

Amazonas 0	Lambayeque 1%	Amazonas 0	Lambayeque 1%
Ancash <1%	Lima 15%	Ancash <1%	Lima 16%
Apurímac 17%	Loreto <1%	Apurímac 6%	Loreto <1%
Arequipa 0	Madre de Dios 0	Arequipa 0	Madre de Dios 0
Ayacucho 31%	Moquegua 0	Ayacucho 38%	Moquegua 0
Cajamarca <1%	Pasco 4%	Cajamarca <1%	Pasco <1%
Cusco 5%	Piura 3%	Cusco 4%	Piura 3%
Huancavelica 6%	Puno 2%	Huancavelica 8%	Puno 2%
Huánuco 6%	San Martín 1%	Huánuco 7%	San Martín 2%
Ica 0	Tacna 0	Ica 0	Tacna 0
Junín 5%	Tumbes <1%	Junín 6%	Tumbes <1%
La Libertad <1%	Ucayali 2%	La Libertad <1%	Ucayali 3%
<b>Sexual Violence by Location</b>			
Occurred in private locations 69%		Occurred in private locations	
Occurred in state-run detention centers 43%		Occurred in state-run detention centers	
<b>Context</b>			
Perpetrated to coerce confession/interrogate victim 12%		Perpetrated to coerce confession/interrogate victim	

**Table 6.1 State-Perpetrated Sexual Violence, All Sexual Violations and ICC Violations Compared**

### Victim Profile

In this section, I will describe the general profile of a victim of state violence during the Peruvian civil war, and then consider the ways in which victims of sexual violence differed from this broader victim population. Included in the database are 8,299 unique victims, individuals who suffered at least one of the forms of political violence described above. According to testimonial accounts, the majority (67 percent) of victims experienced a single form of violence. Thirty-two percent of victims experienced two or three forms of violence. About one percent of victims reported suffering four or five forms of violence.

Most victims of political violence during the civil war were married or partnered men of young adulthood or middle age, had some level of primary or elementary education, were peasants by occupation, spoke both Quechua and Spanish and practiced Catholicism (see Figures 7.3-7.10 below).<sup>135</sup> Most victims did not report belonging to

<sup>135</sup> Of those who reported being married or partnered, most were not formally married. In addition to the cost of the wedding ceremony itself, many citizens in Peru cannot afford to travel and pay for a proper, legal identification card (particularly, in isolated, rural areas), which is required to be formally married. As

any social, cultural or political organizations,<sup>136</sup> but of those who did, the most common affiliations were to agricultural cooperatives or other peasant organizations, human rights groups, labor unions and opposition political parties or groups.<sup>137</sup> Reflective of the state's *and* the Shining Path's exclusionary ideologies and security doctrines, victims were frequently accused of being terrorists or "traitors of the revolution," or both. Finally, as the war continued, it became more and more common for victims of political violence to report having suffered a previous attack against themselves or a loved one, having witnessed such an attack, or having attempted to file a formal denunciation of abuse with the state security/legal apparatus or a human rights organization. This was reported to be the case for 10 percent of victims.

Victims of sexual violence differed from victims of other human rights violations in substantively meaningful and statistically significant ways. There were 622 unique victims of sexual violence, each of whom suffered between one and four types of sexual violation. Most were married Catholic women between the ages of 25 and 44, with at least an elementary-level education, and who spoke both Spanish and Quechua. However, within this general characterization, there is important variation.

While the vast majority of sexual violence victims were women, 29 percent were men, a figure far greater than previously thought or predicted by the literature on wartime sexual violence. Interestingly, the ways in which men and women were sexually

---

a result, there has been a longstanding tradition of *compañerismo*, or informal partnering. More recently, in Lima, for those who can afford it, couples that wish to be formally married often do so in mass ceremonies to offset some of the costs.

<sup>136</sup> It is likely that participation in social, cultural and political organizations is dramatically underreported, as such memberships were highly politicized during the war, and often became the basis of targeting individuals for violence.

<sup>137</sup> In fact, the most commonly reported organizational memberships were to armed organizations, including the Shining Path, the MRTA, the state armed forces, or the *Comités de Autodefensa* (CADs, Civilian Self-Defense Committees). I report organizational affiliations excluding these groups to reflect the most common types of social and political mobilization prior to the civil war.



victimized were also quite different. Of those who reported being sexually assaulted, women were most likely to be raped or gang raped (82 percent), forcibly stripped or otherwise sexually humiliated (20 percent), or sexually tortured (14 percent). On the other hand, men were most likely to be humiliated and mocked in sexually explicit ways (64 percent), sexually tortured (22 percent), or have their genitals removed or otherwise permanently disfigured (12 percent). Only 12 percent of male victims of sexual violence were raped or gang raped.<sup>138</sup>

The vast majority (78 percent) of victims could read and write. Victims of sexual violence and other forms of political violence differed significantly in their level of education (Pearson  $\chi^2(4) = 34.0154, p < 0.001$ ).<sup>139</sup> In particular, victims of sexual violence were significantly more likely to have a university degree or some advanced technological training.

In Peru, an individual's mother tongue is often used as a proxy for his/her ethnic identity.<sup>140</sup> Most victims of state violence during the war reported Quechua as their mother tongue (70 percent). An important distinction should be made, however, between individuals who continue to speak only Quechua (40 percent) and those who later learned Spanish (60 percent), as the latter may imply a different socio-economic or political positioning within Peruvian society.<sup>141</sup> Regarding language, there is a significant

---

<sup>138</sup> The figures reported here refer to the percentage of all sexual violations against men (or women) that fall under each category. Because victims often suffer more than one form of sexual violence, figures add up to more than 100 percent.

<sup>139</sup> All reported significance values refer to  $\chi^2$  tests where the null hypothesis ( $H_0$ ) is that there is no significant difference between victims who are sexually violated and those who are not.

<sup>140</sup> Many scholars have noted that this is a poor measure of ethnicity, particularly in the northern regions where many people speak Spanish regardless of their ethnic origin. For the central sierra region, where Quechua-speaking people are usually from an indigenous background, mother tongue is a better approximation for ethnicity (Portugal 2008, 24).

<sup>141</sup> My coding of victim language differs slightly from the CVR's four-way categorical variable of mother tongue. The CVR categorized victims' mother tongue as either: (1) Spanish, (2) Quechua, (3) some other

difference between victims of sexual and victims of other forms of abuse (Pearson  $\chi^2(4) = 12.4501, p=0.01$ ). This is due largely to the fact that victims of sexual violence are more likely than expected to speak Spanish as their mother tongue and less likely to only speak a native language, a finding that does not support the CVR's profile of victims of sexual violence.

Victims of sexual violence were also much more likely than expected to be housewives (Pearson  $\chi^2(1) = 26.4940, p<0.001$ ).<sup>142</sup> This is not surprising, however, given the gender distribution of sexual violence victims and that this occupational category is gender specific. Lastly, victims of sexual violence are much less likely to be soldiers, police officers or otherwise work as a state security officer (Pearson  $\chi^2(1) = 19.2775, p<0.001$ ). Members of the armed forces who enter into the database as victims of state violence are much more likely to die during a battle in which state armed forces are involved than they are to suffer sexual violence. There are only three cases reported in which members of the armed forces perpetrated sexual violence against members of other *regular* security groups.<sup>143</sup>

---

indigenous or native language, or (4) some other language. Instead of mother tongue, my coding scheme more closely reflects the language(s) spoken by the victim: (1) Spanish only, (2) Quechua only, (3) Spanish and Quechua, (4) some other indigenous or native language, or (5) some other language.

<sup>142</sup> Victims of sexual violence are also more likely to be workers (Pearson  $\chi^2(1) = 6.1872, p<0.05$ ), professionals, such as dentists or lawyers (Pearson  $\chi^2(1) = 7.6949, p<0.01$ ), or otherwise employed, such as musicians and artisans (Pearson  $\chi^2(1) = 14.6895, p=0.001$ ). However, all of these results are based on small N and do not persist when analyzing only those cases of sexual violence recognized by the ICC.

<sup>143</sup> There are, however, a few seemingly isolated cases, where members of the CADs are targeted for sexual violence, often because they come under the suspicion of the military. Emblematic of these cases, Alfonso and his wife Isidora, both members of the CAD in Chiclayo (in the Lambayeque region), were taken from their home on December 1, 1991 by members of the counter-terror police, DINCOTE (*Dirección Nacional Contra el Terrorismo*, Counter-Terrorist Directorate). They were accused of being members of the MRTA rebel group. Before being transferred to the offices of DINCOTE and later to prison, both were taken to the beach, a favorite locale of DINCOTE officers to commit violence due to its seclusion and darkness. On the beach, both were stripped and tortured. The police threatened to rape Isidora if Alfonso did not tell them what they wanted to hear. Alfonso repeatedly told the officers that he did not know anything about the MRTA or its members. The police raped Irene in front of her husband and beat him until he was unconscious. Present and participating in the acts were DINCOTE Captain Casas and police Lieutenant Alberto Velasquez. Isidora was later released, but Arturo was convicted of crimes of terrorism at a faceless

Victims of sexual violence more often reported being the member of a social, political or religious organization than victims of other human rights violations, however the difference is not statistically significant. As mentioned above, there is reason to suspect that people were reluctant to admit affiliations with such organizations for fear that it may make them a target of state suspicion and repression. Victims of sexual violence are more often reported as members of developmental or assistance-based organizations (such as the *Vaso de Leche* program that provides a glass of milk to school children in rural communities) (Pearson  $\chi^2(1) = 16.1074$ ,  $p < 0.001$ )<sup>144</sup> or parent associations (Pearson  $\chi^2(1) = 8.9852$ ,  $p < 0.001$ ) than is expected. Lastly, given the frequency with which the state committed acts of violence against suspected or real members of the Shining Path and MRTA, it is surprisingly infrequent how often subversives report being the victims of sexual violence (Pearson  $\chi^2(1) = 31.6862$ ,  $p < 0.001$ ). Although victims of sexual violence were more likely to be civilians (Pearson  $\chi^2(1) = 59.9628$ ,  $p < 0.001$ ), they were more likely than other victims to be accused of terrorism (Pearson  $\chi^2(1) = 70.6522$ ,  $p < 0.001$ ).

Victims of sexual violence experienced, on average, more violations of their human rights (Pearson  $\chi^2(4) = 1.5e+03$ ,  $p < 0.001$ ). It was quite rare for an individual to be targeted for sexual and no other forms of violence. As a result, victims of sexual violence were much more likely to experience two to ten human rights violations.

Interestingly, victims of sexual violence were much less likely to be killed after the

---

military tribunal and sentenced to 20 years in prison where he remains today. Cases such as this one, however, are uncommon, as indicated by the fact that sexual violence victims are significantly (20 times) less likely to be members of CADs than expected, given their overall representation within the database (Pearson  $\chi^2(1) = 21.5065$ ,  $p < 0.001$ ). In other words, members of CADs who enter into the database as victims of violence are much more likely to suffer some form of lethal violence than non-lethal violence, particularly sexual violence.

<sup>144</sup> This difference is based on a small N and thus should be interpreted with caution. When sexual violence is restricted to those violations recognized by the ICC, this finding disappears.

assault (Pearson  $\chi^2(1) = 283.6177$ ,  $p < 0.001$ ). Victims of sexual violence were 1.5 times more likely than predicted to have previously witnessed a violent attack than victims of other forms of violence (Pearson  $\chi^2(1) = 6.9872$ ,  $p < 0.01$ ).

This profile differs significantly from what the Peruvian Truth and Reconciliation Commission reported regarding victims of sexual violence. In the final report, the CVR characterized victims of sexual violence as almost exclusively young women (99%),<sup>145</sup> between the ages of 10 and 29, who completed only an elementary education and whose mother tongue was Quechua (CVR 2003). The data presented here support the CVR's conclusion that many victims of sexual violence were female Quechua-speakers who lived in rural Andean communities and who did domestic and agricultural work. There is another type of victim, however, that is not captured by the CVR's report. This person, whether male or female, is generally older, more educated, resides in urban centers, speaks Spanish, and has become the target for sexual violence because of his/her political activities or affiliations. In these cases, sexual violence is often used as a method of torture to punish, coerce or interrogate the victim, and occurs within state-run detention facilities.

More importantly, the evidence presented above indicates that victims of sexual violence were significantly different than victims of non-sexual human rights violations. Individuals were not randomly targeted for sexual violence as the opportunity model would suggest. Victims of sexual violence were often highly educated, residents of urban centers who participated in activities labeled by the state as "subversive." Such activities

---

<sup>145</sup> In the CVR's final report, it indicated that 98 percent of sexual violence victims were women and 2 percent were men. Examining the CVR's database (*Base de Datos de la Comisión para la Verdad y Reconciliación*, BDCVR) reveals only one case (not the eleven mentioned in the final report) of sexual violence against a man. Accordingly, men comprised less than 1 percent of the victims of sexual violence recorded by the CVR.

include actual subversion or militancy, unionizing or protesting state human rights abuses. Because of the tradition of the Shining Path to recruit young members from schools, even high school and university teachers came under the suspicion of the state. That these individuals were targeted for abuse is not surprising when one understands how the Peruvian state framed the opposition during the conflict. That university students, community leaders, human rights activists and journalists were often accused of being “terrorists” or sympathizers put them at risk for sexual and other forms of political violence. While there is no evidence of a mandate by state leaders to carry out sexual violence, by framing the national security discourse so broadly and antagonistically, central government leaders gave license to individual soldiers to equally punish unarmed and armed political opponents. This finding, that sexual violence is targeted against particular subgroups within the population, is preliminary and alone cannot refute with certainty the opportunity model of violence. In the following section, I explore an additional piece of the puzzle – who commits sexual violence during times of war?



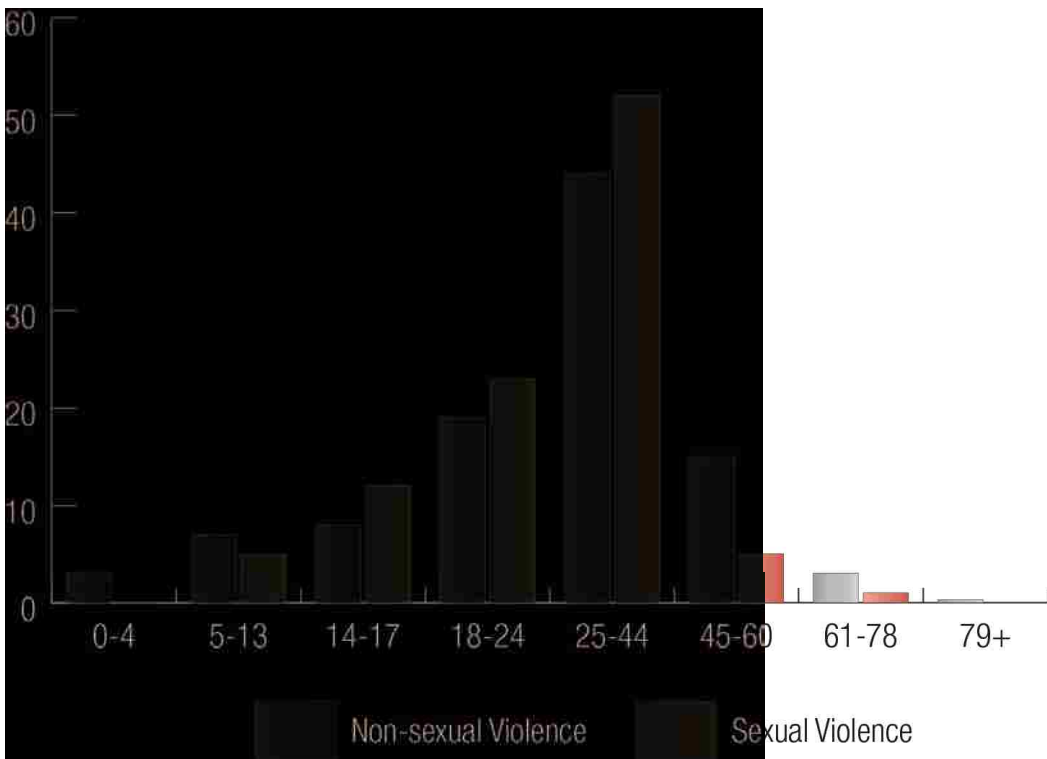

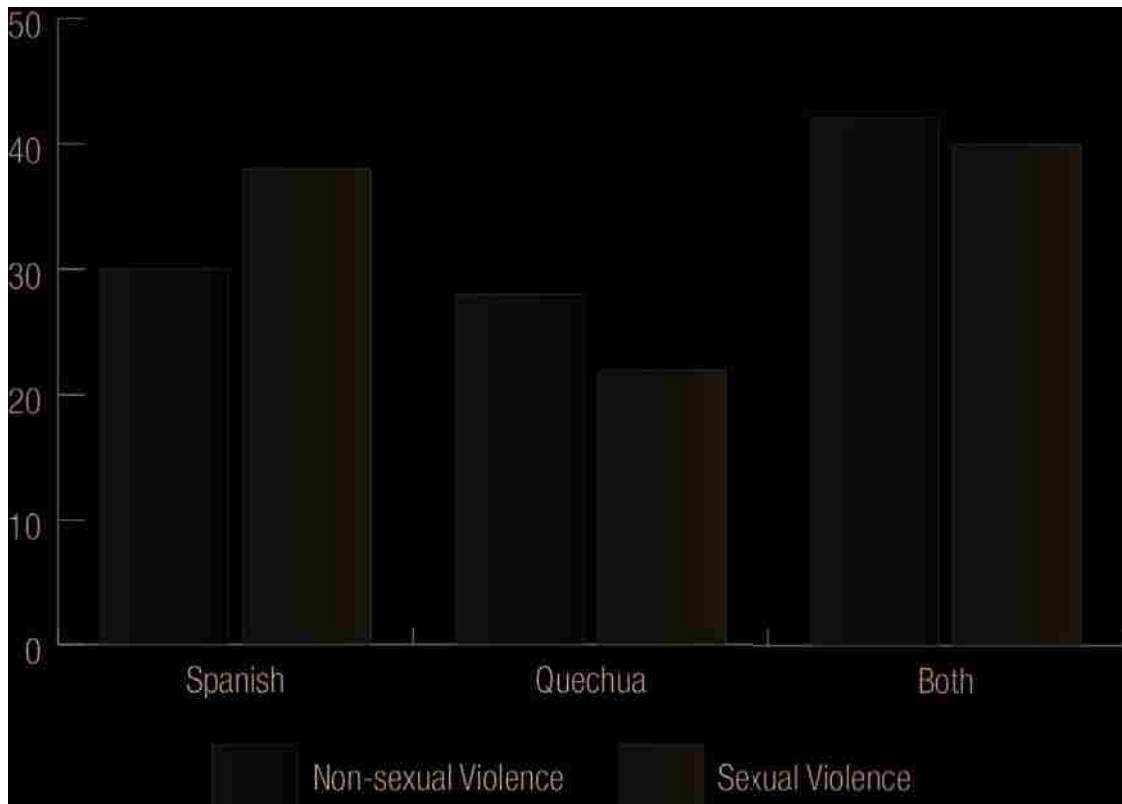

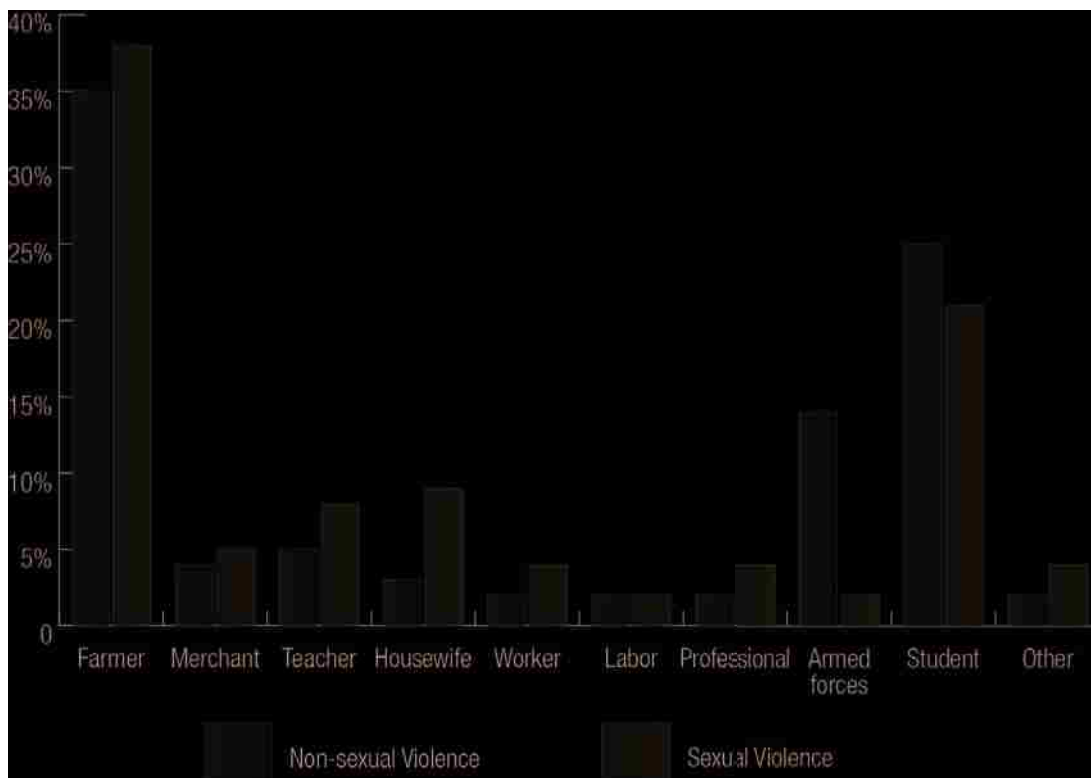





**Figures 6.3-6.10: Demographic Profile of Victims of State-Perpetrated Sexual and Other Types of Violence in Peru, 1980-2002**

<b>ALL SEXUAL VIOLENCE (INCLUDING SEXUAL HUMILIATION AND COERCION)</b>	<b>SEXUAL VIOLENCE ACCORDING TO THE ICC</b>
622 unique victims of sexual violence	414 unique victims of sexual violence
<b>Gender</b>	
Women 71%	Women 82%
Men 29%	Men 18%
<b>Education</b>	
Literate 78%	Literate 71%
No formal education 15%	No formal education 20%
Initial schooling 1%	Initial schooling 1%
Elementary education 36%	Elementary education 34%
High school education 22%	High school education 21%
Advanced education 27%	Advanced education 24%
<b>Marital Status</b>	
Single 38%	Single 41%
Married/Partnered 59%	Married/Partnered 56%
Divorced 1%	Divorced 0%
Widowed 2%	Widowed 3%
<b>Age</b>	
0-4 years 0%	0-4 years 0%
5-13 years 5%	5-13 years 6%
14-17 years 12%	14-17 years 14%
18-24 years 23%	18-24 years 27%

25-44 years 52% 45-60 years 5% 61-78 years 1% 79+ 0	25-44 years 46% 45-60 years 5% 61-78 years 2% 79+ 0
<b>Religion</b>	
Catholic 84% Evangelical 15% Atheist 2%	Catholic 82% Evangelical 15% Atheist 3%
<b>Language</b>	
Spanish only 38% Quechua only 22% Spanish & Quechua 40%	Spanish only 35% Quechua only 24% Spanish & Quechua 40%
<b>Occupation<sup>146</sup></b>	
Farmer 38% Merchant 5% Teacher 8% Housewife 9% Worker 4% Laborer 2% Professional 4% Armed Forces 2% Student 21% Other 4%	Farmer 45% Merchant 4% Teacher 9% Housewife 12% Worker 7% Laborer 2% Professional 3% Armed Forces 1% Student 25% Other 4%
<b>Organizational Affiliations<sup>147</sup></b>	
Human rights 30% Peasant 15% Assistance/Development 25% Cooperative 5% Political party 10% Labor/Union 30% Student 10% Neighborhood association 0 Parent association 20% Recreation 5% Religious 10%	Human Rights 27% Peasant 17% Assistance/Development 6% Cooperative 0 Political party 6% Labor/Union 22% Student 6% Neighborhood association 0 Parent association 17% Recreation 6% Religious 11%
<b>Conflict Histories</b>	
8% of victims suffered other human rights violations prior to the sexual attack. 15% of victims knew someone who suffered other human rights violations prior to the sexual attack against themselves. 5% of victims witnessed another human rights violation prior to the sexual attack.  24% of victims were accused by state authorities of terrorism. 2% of victims knew someone who was accused by state authorities of terrorism.	8% of victims suffered other human rights violations prior to the sexual attack. 17% of victims knew someone who suffered other human rights violations prior to the sexual attack against themselves. 6% of victims witnessed another human rights violation prior to the sexual attack.  24% of victims were accused by state authorities of terrorism. 3% of victims knew someone who was accused by state authorities of terrorism.

**Table 6.2 State-Perpetrated Sexual Violence, Victims of All Sexual Violations and Victims of ICC Violations Compared**

<sup>146</sup> Figures may be greater than 100 percent as individual victims may report having more than one job.

<sup>147</sup> Figures may be greater than 100 percent as individual victims may report belonging to more than one social or political organization.

## Perpetrator Profile

The state armed forces participated in 61 percent of all human rights violations committed during the war, while non-state armed groups participated in 36 percent of all human rights violations.<sup>148</sup> The state armed forces, however, are responsible for 88 percent of all sexual abuse, a figure significantly higher than expected (Pearson  $\chi^2(1) = 233.3344$ ,  $p < 0.001$ ) (see figures 7.11 and 7.12 below for a breakdown of violations committed by state and non-state actors). The most frequent forms of sexual violence engaged in by the state were: rape and gang rape (42 percent), sexual humiliation (34 percent), and sexual torture (12 percent). The only significant difference in violation type according to perpetrator group is that non-state armed actors were significantly more likely to commit acts of sexual mutilation and disfigurement than were state armed actors (Pearson  $\chi^2(1) = 42.4294$ ,  $p < 0.001$ ). Sexual mutilation comprised 20 percent of all acts of sexual violence perpetrated by non-state armed groups.

Within the state armed forces, there is great variation in the levels and types of violence perpetrated by the regular army, the national police, and specialized counter-terror squads (see Table 6.3 for a list of major state armed groups in Peru). The army perpetrated more sexual violence than any other state armed group (32 percent). Most often, soldiers committed rape (32 percent), gang rape (18 percent), and sexual

---

<sup>148</sup> This is significantly different from the final report of the CVR, which stated that the Shining Path alone was responsible for 54 percent of all lethal violence during the war. There are two reasons for this disparity in findings. First, all battle-related deaths and battle massacres in my database are reported as having at least two responsible parties to represent each of the combating forces. During active combat situations it is difficult to discern who exactly was responsible for any given death or injury. Because my data come from victim, witness and their loved ones' testimonies it is almost impossible to attribute each battle-related incident to one, specific armed group. Thus, I record all armed groups involved in the battle as perpetrators of battle-related violations. Second, the CVR did not record violence against any person for whom they could not identify by first and last name. Because of the clandestine nature of rebel groups, it is very rare that the names of individual members are known (with the exception of the top leadership or others of prominence and notoriety within the group). As a result, the extrajudicial execution, torture or other human rights violations against members of the Shining Path and MRTA are rarely included in the CVR's database, resulting in an overall depression of the percentage of violations attributable to the state.

humiliation (39 percent). Contrast this with the patterns of sexual abuse by the *Policía Nacional del Perú* (PNP, Peruvian National Police). The PNP perpetrated more sexual violence than expected (Pearson  $\chi^2(1) = 40.6356, p < 0.001$ ). However, police officers did not commit rape or gang rape nearly as often as soldiers (14 and 7 percent of all PNP-perpetrated sexual violence), but rather frequently sexually humiliated (42 percent) and engaged in the sexual torture of prisoners (almost 20 percent) (see Figure 6.13). It is plausible that sexual violence perpetrated by soldiers is more likely to be opportunistic than that perpetrated by police officers. Soldiers are more likely to operate in small groups that are deployed to geographically distant areas for prolonged periods of time. It is harder to make the argument that sexual torture, violence that requires access to specialized equipment and is often executed methodically, is opportunistic.

Of greater interest to the opportunity model is the notable absence of sexual violence on the part of those organizations that are deliberately designed to operate outside of the command control hierarchy of the armed forces, namely the CADs (*Comités de Autodefensa Civil*, Civilian Self-Defense Committees),<sup>149</sup> also known as the *rondas*, or paramilitary groups such as the Comando Rodrigo Franco (Rodrigo Franco Command)<sup>150</sup> or the Grupo Colina (Colina Group).<sup>151</sup> The CADs were indicated in 7 percent of all state violence during the civil war, but only 4 percent of all sexual violence,

---

<sup>149</sup> Although community-based, the CADs are considered state armed groups because they were not only allowed to exist as armed militias, but were in fact funded and armed by the government. The administrations of Alan García (1985-1990) and Alberto Fujimori (1990-2000) distributed approximately 10,000 rifles to some 4,000 self-defense groups (McClintock 1999).

<sup>150</sup> The Rodrigo Franco Command is a death squad that formed out of the ranks of *Dirección Contra el Terrorismo* (DIRCOTE, Counter-Terrorist Directorate, later renamed DINCOTE) and closely aligned to the *Alianza Popular Revolucionaria Americana* (APRA, American Popular Revolutionary Alliance).

<sup>151</sup> The Colina Group is an anti-communist death squad created during Alberto Fujimori's presidency. It is responsible for the Barrios Altos, La Cantuta, and the Santa massacres.

significantly less than predicted (Pearson  $\chi^2(1) = 7.3613, p < 0.01$ ).<sup>152</sup> When members of CADs did engage in sexual violence, they were significantly more likely to commit rape or gang rape than other forms of sexual abuse; 93 percent of all sexual violence perpetrated by CADs was rape or gang rape. There were no reports of sexual violence perpetrated by paramilitary groups. That these groups were permitted to commit numerous selective assassinations and sometimes large-scale massacres without punishment from the military high command, *but* did not use this latitude to also engage in privately motivated acts of sexual violence does not support the opportunity model.

Although the CADs operated with little to no official oversight and their members were often required by the military to serve,<sup>153</sup> because they were often “recruited” from neighboring communities, they may be less likely to engage in sexual violence as the inhabitants of the villages where the CAD patrol reflect the same social and ethnic background.

The absence of sexual violence perpetrated by paramilitary groups is more perplexing. These organizations were often comprised of retired military officers to create a “fictitious separation from service” and to avoid potential charges within the military justice system (Sala Penal de la Corte Suprema 2009, 704). Indicative of the organization of many paramilitary groups operating in Peru, the Special Intelligence Detachment of the Colina Group, routinely had its members submit applications for

---

<sup>152</sup> Given the rates of sexual violence in the database and the rate of violence perpetrated by paramilitary groups, there is no significant difference between the expected and observed rates of sexual abuse by paramilitary organizations (Pearson  $\chi^2(1) = 1.9692, p = 0.161$ ).

<sup>153</sup> The creation and organization of the CADs often proceeded as follows: In collaboration with local leaders who were sympathetic to the government and armed forces, the Army would organize a town meeting, which all (male) residents of the community were obliged to attend. Those who did not attend this first meeting were subject to police harassment; they would be detained and questioned and forced to supply a list of witnesses who could confirm their whereabouts during the meeting and their reasons for not attending. A second meeting would then be called; those who did not attend were often detained on “suspicion of collaborating with terrorists” or killed (NSA Dec 19, 1999 “Extrajudicial Killings”).

retirement from their regular posts in the armed forces before joining.

Also of significance to the opportunity model is the presence or absence of commanding officers during the commission of the criminal violence. The theory of sexual violence as opportunistic violence expressly rejects the possibility of the presence of leaders. It argues that principals do not want their subordinates to commit sexual violence, and therefore would prevent it or stop it from occurring if they could. The data from Peru indicate that commanders were present during at least 23 percent of all sexual violence cases. This is significantly higher than expected (Pearson  $\chi^2(1) = 4.4209$ ,  $p < 0.05$ ).<sup>154</sup> Commanders should neither be present, know of and not adjudicate, and certainly not order or otherwise encourage the use of sexual violence by their subordinates. While it is possible for a high-ranking military officer to behave as an opportunistic or rogue agent, given that they are better trained and more highly educated than rank-and-file soldiers, it is unreasonable to argue that large numbers of officers would behave in this way. Moreover, several members of the high-ranking military leadership are cited repeatedly as having been present during the commission of criminal violence, including Army Captain “Gato,” Captain Carranza of the Guardia Republicana, Army Lt. “Negro” (equivalent to 1<sup>st</sup> Lieutenant in U.S. Army), Army Captain Cadenas, Army Lt. Martinez (equivalent to 1<sup>st</sup> Lieutenant in U.S. Army), and Army Major Zamore. Some of these same officers are direct participants in acts of sexual violence, including Police Captain Carranza (director of the Castro Castro prison), Army Major Zamore, Army Captain “Gato,” Police Colonel Tijeras, Army Lt. Martinez, and Colonel Mario Ramirez of DINCOTE Delta 5. Consider the following example:

---

<sup>154</sup> Commanding officers were present in 27 percent of cases of sexual violence codified as war crimes by the ICC (this is more frequent than expected, Pearson  $\chi^2(1) = 17.5528$ ,  $p < 0.001$ ).

Leonardo was at a meeting of the leftist political party *Izquierda Unida* (IU, United Left) on October 16, 1988 when he was arrested, accused of being a member of the Shining Path. “The government always said that all leftist organizations and political opposition groups were terrorist organizations, but that wasn’t so. In fact, a lot of members of these groups also had problems with the Shining Path” (CVR Testimonies 100403). Leonardo was blindfolded and taken by plainclothes officers of the *Policía de Investigaciones del Perú* (PIP, Peruvian Investigative Police) to the local PIP station. While detained he was subjected to severe psychological and physical torture. Officers threatened to capture his parents and treat them the same way if he did not cooperate with them. Coronel Cubillas Arizaga and Captain Lizarraga oversaw the torture of Leonardo and actively participated in what they called *la mariposa* – where the prisoner is forced to stand with his hands tied behind his back, is submerged in water and then electrocuted on his tongue, armpits and testicles (CVR Testimonies 100403, 100471, 100472). The participation of such high-ranking officials within the organization and the context in which the violence was perpetrated (during interrogations and an attempt to force the prisoner to sign a confession) indicates that this violence was not purely opportunistic. It was not motivated by low-level members acting on their own behest to satisfy personal desires for power or gratification.

<b>Army:</b>
<ul style="list-style-type: none"> <li>• In 1992, the size of the Peruvian Army was estimated at 80,000 officers and enlisted soldiers.<sup>155</sup></li> <li>• Charged with protecting the sovereignty and territorial integrity of the country.</li> <li>• Charged with restoring internal order during states of emergency.</li> </ul>
<b>Policía Nacional del Perú (PNP, Peruvian National Police):</b>
<ul style="list-style-type: none"> <li>• Guardia Civil del Perú (GC, Peruvian Civil Guard), main preventative police force in Peru,</li> </ul>

<sup>155</sup> The Peruvian army is the second largest in South America and is the largest military service branch in the country (United States Army Intelligence Agency, Intelligence and Threat Analysis Center. 1992. *Army Country Profile: Peru*. Washington, DC: National Security Archive Collection “Peru in ‘The Eye of the Storm’” National Security Archive Electronic Briefing Book No. 64 <http://www.gwu.edu/~nsarchiv/NSAEBB/NSAEBB64/peru32.pdf> p.30)

<p>maintains public order, prevents crime, protects citizens and property, maintains free movement on public roads.</p> <ul style="list-style-type: none"> <li>• Guardia Republicana del Perú (GR, Peruvian Republican Guard), in charge of border control, guarding significant government buildings, and has custody of prisons. Before 1977, the GR lacked its own training procedures and facilities, so often recruited directly from the Army.</li> <li>• Policía de Investigaciones del Perú (PIP, Investigative Police of Peru), often plainclothes officers, conduct forensic investigations.</li> </ul>
<b>Special Police Forces:</b>
<ul style="list-style-type: none"> <li>• Subunidad de Acciones Tácticas (SUAT, Special Tactics Unit), counterterrorism special police force.</li> <li>• Dirección Contra el Terrorismo (DIRCOTE, Counter-Terrorism Directorate), previously known as Dirección Nacional contra el Terrorismo (DINCOTE, National Directorate against Terrorism), counterterrorism special police force.</li> <li>• SINCHIS, counterterrorism special police battalion, trained in the U.S. with close ties to the U.S. Green Berets.</li> <li>• Grupo Especial de Inteligencia (GEIN, Special Intelligence Group), collect information and conduct investigations into the leaders of domestic terrorist organizations, carried out operation in 1992 that resulted in the capture of Abimael Guzmán, leader of the SL-PCP.</li> </ul>
<b>Paramilitary Organizations:</b>
<ul style="list-style-type: none"> <li>• Servicio de Inteligencia Nacional (SIN, National Intelligence Service).</li> <li>• Comando Rodrigo Franco (Rodrigo Franco Command), closely aligned to the political party APRA.</li> <li>• Grupo Colina (Colina Group), established under Fujimori, comprised mostly of “retired” members of the regular Army, closely aligned with the SIN.</li> </ul>

**Table 6.3 State Armed Forces in Peru**



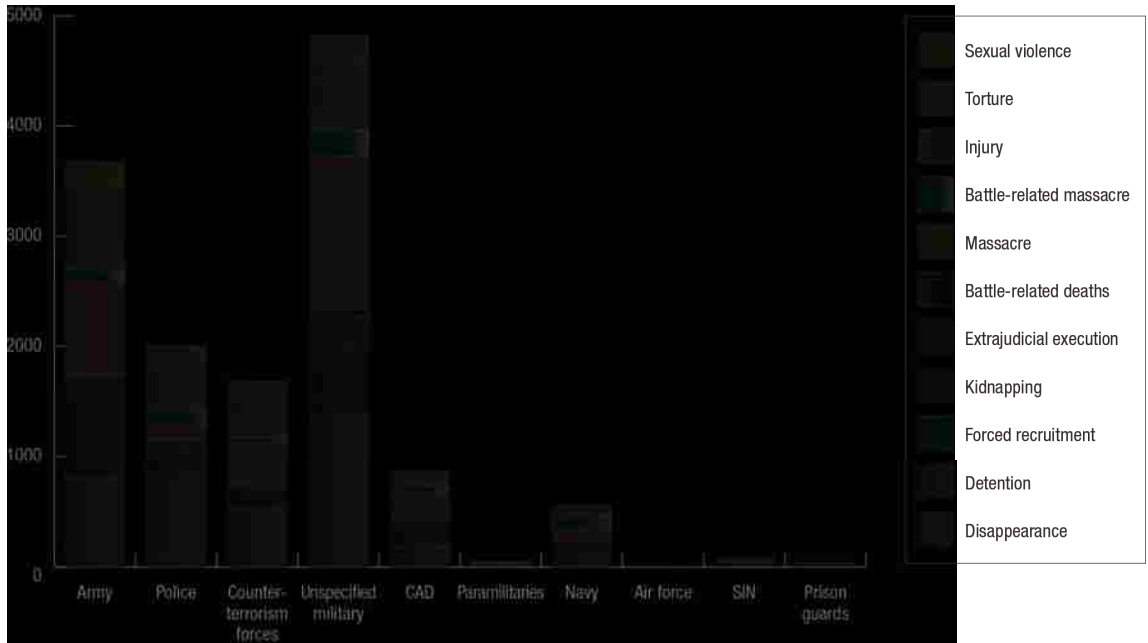

Figure 6.11 Repertoires of Violence by State Armed Groups

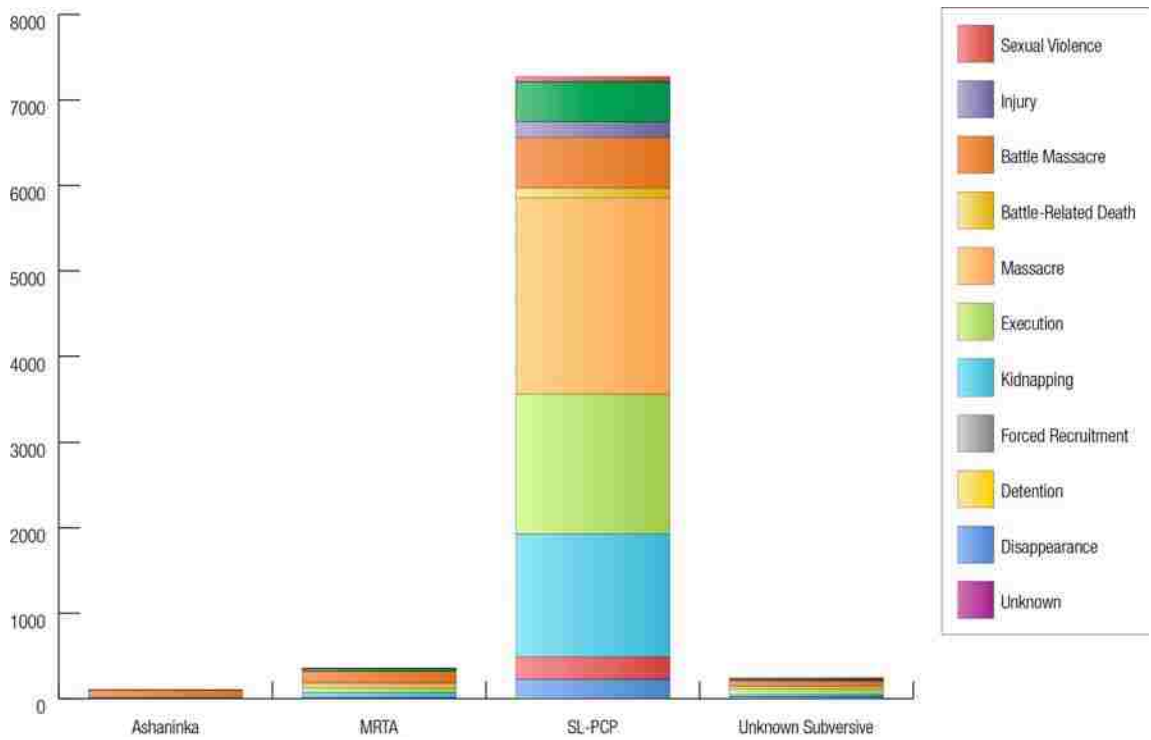

Figure 6.12 Repertoires of Violence by Non-State Armed Groups

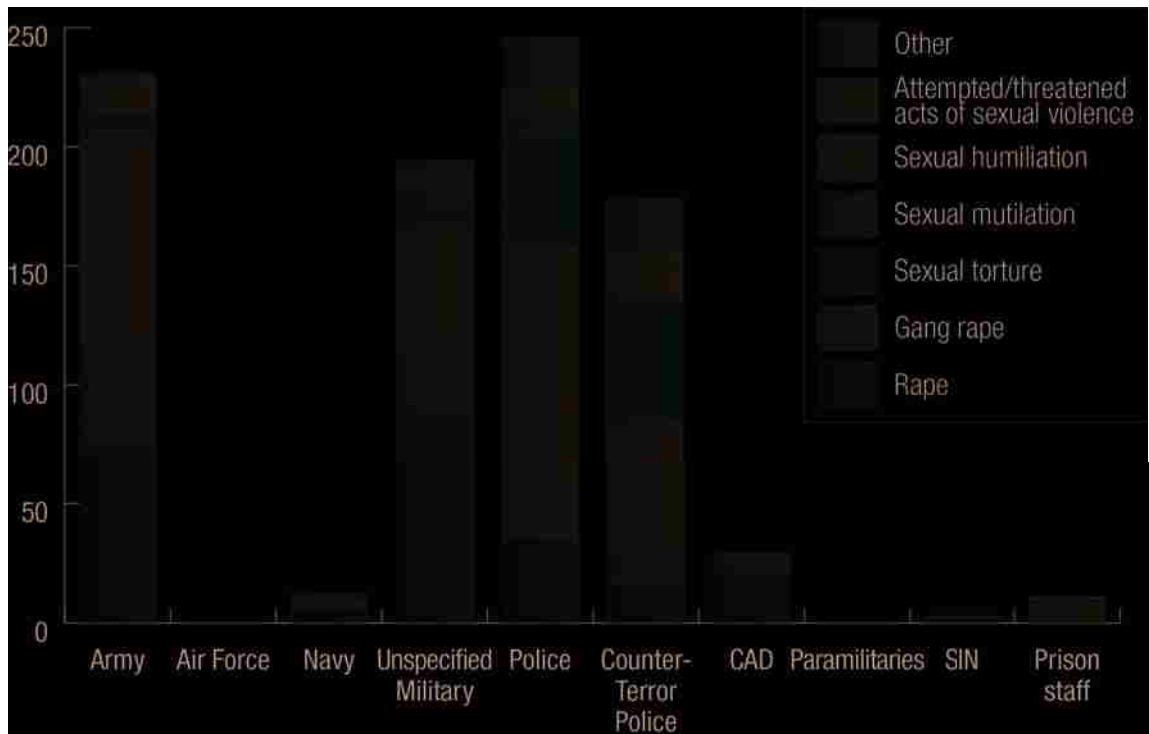

Figure 6.13 Sexual Violence by State Armed Groups

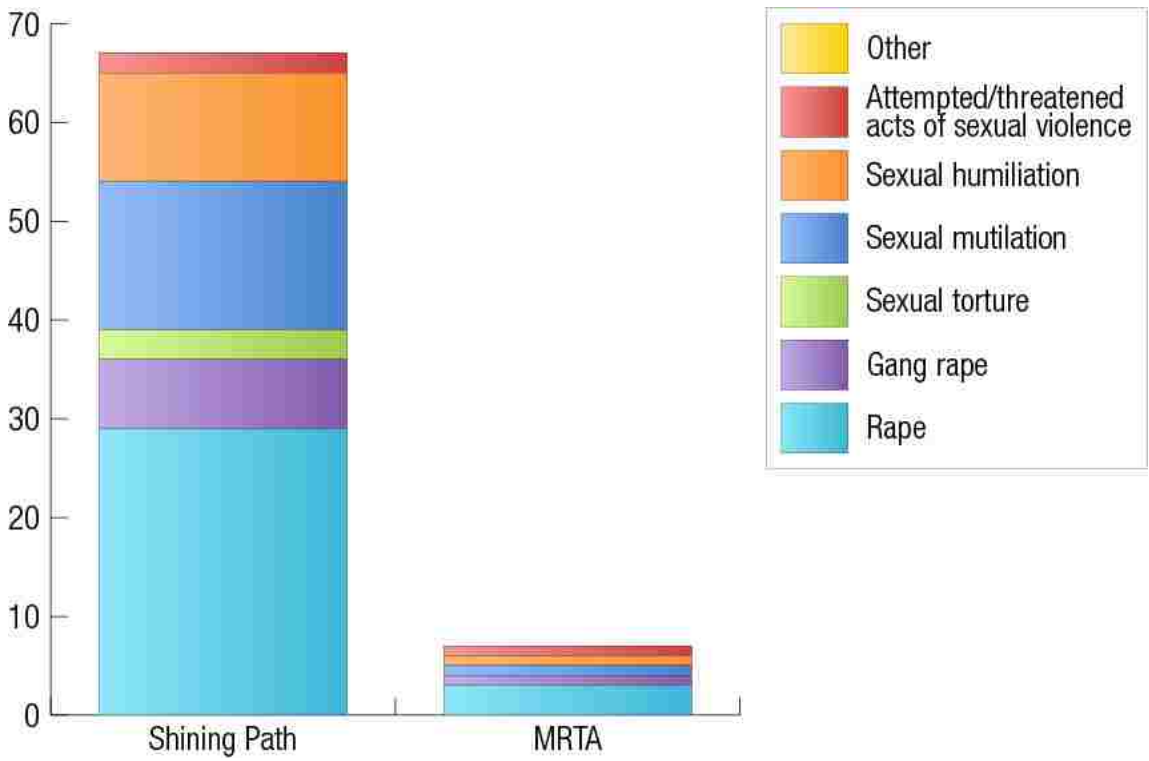

Figure 6.14 Sexual Violence by Non-State Armed Groups

<b>ALL SEXUAL VIOLENCE (INCLUDING SEXUAL HUMILIATION AND COERCION)</b>	<b>SEXUAL VIOLENCE ACCORDING TO THE ICC</b>
<b>Army</b>	
Rape 32% Gang rape 18% Sexual humiliation 39% Sexual torture 3% Sexual mutilation 1% Sexual coercion 6% Other 1%	Rape 58% Gang rape 33% Sexual torture 5% Sexual mutilation 2% Other 2%
<b>Navy</b>	
Rape 50% Gang rape 8% Sexual humiliation 17% Sexual torture 25% Sexual mutilation 0 Sexual coercion 0 Other 0	Rape 60% Gang rape 10% Sexual torture 30% Sexual mutilation 0 Other 0
<b>Unspecified Military</b>	
Rape 46% Gang rape 15% Sexual humiliation 25% Sexual torture 6% Sexual mutilation 4% Sexual coercion 2% Other 3%	Rape 64% Gang rape 21% Sexual torture 7% Sexual mutilation 6% Other 2%
<b>National Police</b>	
Rape 14% Gang rape 7% Sexual humiliation 42% Sexual torture 19% Sexual mutilation 4% Sexual coercion 4% Other 9%	Rape 27% Gang rape 13% Sexual torture 35% Sexual mutilation 7% Other 17%
<b>Counter-Terrorism Police</b>	
Rape 9% Gang rape 8% Sexual humiliation 31% Sexual torture 29% Sexual mutilation 1% Sexual coercion 10% Other 13%	Rape 16% Gang rape 14% Sexual torture 48% Sexual mutilation 1% Other 22%
<b>CAD</b>	
Rape 72% Gang rape 21% Sexual humiliation 3% Sexual torture 0 Sexual mutilation 0 Sexual coercion 3% Other 0	Rape 78% Gang rape 22% Sexual torture 0 Sexual mutilation 0 Other 0
<b>SIN</b>	
Rape 67% Gang rape 0 Sexual humiliation 33%	Rape 100%

Sexual torture 0 Sexual mutilation 0 Sexual coercion 0 Other 0	
<b>Prison Guards</b>	
Rape 9% Gang rape 9% Sexual humiliation 55% Sexual torture 18% Sexual mutilation 0 Sexual coercion 9% Other 0	Rape 25% Gang rape 25% Sexual torture 50% Sexual mutilation 0 Other 0
<b>Presence of Commanding Officers</b>	
Commanders present in 23% of cases of sexual violence.	Commanders present in 27% of cases of sexual violence.

**Table 6.4 State-Perpetrated Sexual Violence, Perpetrators of All Sexual Violations and Perpetrators of ICC Violations Compared**

## Conclusion

This chapter described the “who, what, when, where, and how” of violence during the Peruvian civil war. Using inferential chi<sup>2</sup> statistics, it also provided insight into the causes of wartime sexual violence by testing some of the hypotheses of the opportunity model.

The data presented the profile of a “typical” victim of sexual violence by state armed forces, one that is new and distinct in important ways from what was previously known about the war. On average, this person is older than previously thought, lives a more urban lifestyle, and is more educated, and often repeatedly targeted for different forms of violence. Similarly, the data indicate that these individuals were most likely women, raped or gang raped by male soldiers.<sup>156</sup> These attacks most likely occurred in their homes or in state-run detention centers and were more often committed to illicit information or coerce a confession from the victim regarding the membership, movement or location of weapons of the opposition.

<sup>156</sup> In fact, there is only one case of sexual violence perpetrated by a woman in the entire database.

Considered alone, this pattern of perpetration *could* be suggestive of an opportunity model of violence. However, when all the evidence is taken together and the *multiple* patterns of sexual abuse are documented, it becomes evident that opportunity only partially explains the use of sexual violence during the war. For instance, what of the disproportionate targeting of teachers and professors for sexual abuse? Why do patterns of sexual and other forms of violence, such as murder, differ in significant ways? How do we account for the more than one in five acts of sexual violence that is perpetrated with the full knowledge and acquiescence (as demonstrated by their presence) of commanding officers? The opportunity model of violence cannot easily answer these questions.

**PART II:**  
**WARTIME SEXUAL VIOLENCE IN EL SALVADOR, 1978-1992**

## CHAPTER 7

### PRINCIPALS, AGENTS AND STATE-PERPETRATED SEXUAL VIOLENCE IN EL SALVADOR: AN ANALYSIS OF MICRO PATTERNS

#### Introduction

There has been little firsthand academic research on wartime sexual violence in El Salvador. There is little agreement amongst activists and scholars regarding the prevalence of sexual violence during the Salvadoran civil war. Some argue that sexual violence was relatively infrequent, particularly in comparison to the levels of abuse perpetrated during other wars, such as those in the Balkans or even in Guatemala. Others, particularly activists and human rights workers, indicated that rape and sexual torture occurred regularly. There is general consensus, however, that the vast majority of sexual violence was perpetrated by state armed forces. Both sides similarly agree that sexual violence took on two distinct patterns of perpetration: (1) rape of women during incidents of mass violence in rural communities and (2) rape, sexual torture and humiliation of male and female political prisoners.

This chapter begins with a brief overview of the civil war in El Salvador. It then outlines the debate in the literature regarding the frequency of sexual violence during the war. It then presents the data, and limitations therein, from the testimonies collected by Tutela Legal and Socorro Jurídico Cristiano (SJC) on political violence in El Salvador. The remainder of the chapter discusses the repertoire of violence employed by the state armed forces during their counterinsurgency campaign against the FMLN. It describes the victims, perpetrators and contextual patterns of violence, making explicit comparisons between the characteristics of sexual and non-sexual forms of violence. The chapter

concludes by discussing the implications of these findings for our understanding of the causes of state-perpetrated sexual violence in El Salvador.

### **The Civil War in El Salvador, 1978-1992**

Emblematic of class-based conflicts, the Salvadoran civil war was rooted in long-standing economic and political divisions in society. For generations, a small elite class successfully marginalized the rural peasant population and monopolized the country's already limited arable land, such that 3 percent of all landowners controlled 56 percent of the country's arable land. Between 1961 and 1980, the rural landless grew from 11 to 51 percent (Montgomery 1994, 23). As a result, 76 percent of rural families lived in poverty; 55 percent lived in extreme poverty (Wood 2003, 24).

Rampant electoral fraud and political corruption signaled to those already beginning to organize in the 1970s that while occasional promissory carrots might be extended to abate discontent, there would be no restructuring of economic or political relations in El Salvador. The political opposition was systematically blocked from assuming power in 1972, 1974 and 1977.<sup>157</sup> Those already frustrated by an economic system that promoted inequality were galvanized to support small guerrilla groups advocating the armed overthrow of the state. In 1980, five such groups unified under the umbrella of the *Frente Farabundo Martí para la Liberación Nacional* (FMLN, Farabundo Marti National Liberation Front).<sup>158</sup>

---

<sup>157</sup> In 1972, the *Unión Nacional de Oposición* (UNO, National Union of Opposition) candidate, José Napoléon Duarte, was prevented from assuming office by the military. Another UNO victory was blocked in 1974, when the government simply declared that the *Partido de Conciliación Nacional* (PCN, National Conciliation Party) had won.

Amidst accusations of fraud and violence against voters, the PCN candidate, General Carlos Humberto Romero assumed power as the president.

<sup>158</sup> The five factions of the FMLN were: (1) the *Fuerzas Populares de Liberación Farabundo Martí* (FPL, Popular Liberation Forces Farabundo Martí), (2) the *Ejército Revolucionario del Pueblo* (ERP, People's Revolutionary Army), (3) the *Resistencia Nacional* (RN, National Resistance), (4) the *Partido*



Marxist in ideological orientation, the FMLN had strong ties to the Communist governments in Russia and Cuba. The FMLN received a massive amount of international aid – arms, training and money – from abroad.<sup>159</sup> Reflecting its varied composition, the FMLN employed a mix of military tactics and warfare strategies. This flexibility allowed it to respond quickly and effectively to different combat situations and ultimately contributed to its battlefield successes (Bracamonte and Spencer 1995). After the failed 1981 “final offensive,” the FMLN shifted away from urban guerrilla warfare and retreated to the countryside where they prepared for a prolonged “people’s war.”

The military-led government, aided by millions of dollars in US assistance, carried out a policy of widespread repression to defeat the armed insurgency. Unable, and in some cases unwilling, to distinguish between FMLN combatants and its wide civilian support network, the armed forces disappeared or executed tens of thousands of civilians between 1979 and 1981 alone (Peceny and Stanley 2010). Rather than weaken the rebels, the state’s campaign of indiscriminate violence outraged local populations, providing a new pool of potential recruits and supporters for the FMLN.

The only significant shift in the state’s counterinsurgency strategy came in 1984 after sustained US pressure on the armed forces to improve its human rights record. The Salvadoran government was forced to understand, after a visit by then Vice President George H. W. Bush, that the withdrawal of US military support, particularly air support, would almost certainly mean defeat. While the overall level of lethal violence declined,

---

*Revolucionario de los Trabajadores Centroamericanos* (PRTC, Revolutionary Party of Central American Workers, and (5) the *Partido Comunista de El Salvador* (PCS, Salvadoran Communist Party). The FMLN gets its namesake from Augustín Farabundo Martí who led a 1932 peasant uprising in El Salvador. The revolt was quickly and violently crushed by the state military under the direction of Maximiliano Hernández Martínez.

<sup>159</sup> The FMLN also had significant ties to the governments in Nicaragua and Vietnam (Bracamonte and Spencer 1995).

the armed forces' rapid reaction battalions continued to arbitrarily detain and torture those suspected of subversion.<sup>160</sup>

Despite its repressive efforts, the armed forces were unable to militarily defeat the FMLN. Locked in a stalemate, the two sides began to negotiate a settlement in January 1990. Two years later, the FMLN and the Salvadoran government signed the Chapultepec peace accords, ending 12 years of civil war.

### **The Debated Prevalence of Wartime Sexual Violence in El Salvador**

The most significant factor that shapes what we know, and more importantly what we do not know (and possibly can never know) about this phenomenon in El Salvador is the temporal placement of the conflict within the development of the international human rights agenda. The civil war in El Salvador began almost two decades before the international human rights community began to examine the gendered dimensions of conflict. It was not until the systematic rape, impregnation and abuse of women in the former Yugoslavia (1992-1995) and Rwanda (1994) that the international community began to investigate and prosecute sexual violence in conflict situations.<sup>161</sup> As a result, the domestic and international agencies monitoring human rights violations during the Salvadoran civil war were not attuned to the gender or sexual dimensions of political violence. If a survivor spontaneously offered a story of rape or sexual torture, generally,

---

<sup>160</sup> During this time, the state began to pursue social welfare programs, such as the construction of schools and medical facilities in areas where the FMLN boasted support. In comparison to its investment in violent repression, civic action programs of this sort were never a significant component of the state's counterinsurgency strategy.

<sup>161</sup> Responses from the international community included: (1) the recognition of the differential impact of civil war on men and women by UNSC Resolution 1325, (2) the definition of violence against women as a human rights issue at the UN World Conference on Human Rights in 1993, and (3) the codification of the systematic sexual abuse of women as a torture, a crime against humanity, a war crime, and sometimes constituting genocide.

the investigator would record its occurrence. However, investigators were not asking questions to elicit this kind of information from individuals making a denunciation.

The following sections present the disparate reporting of wartime sexual violence in the primary and secondary literatures. Studies characterizing sexual violence as “limited” or rare are considered first, followed by reports describing sexual violence as “widespread and systematic.” The key arguments of each are summarized in Table 7.1.

Source	Frequency	Key Patterns
CVES 1993	Low, 4% of all human rights violations	Asymmetric, perpetrated exclusively by state armed forces Most frequent in early years of war Perpetrated almost exclusively against women
Wood 2006 & 2009	Low	Asymmetric, perpetrated by state armed forces
Cohen 2010	Low <sup>162</sup>	Asymmetric, perpetrated exclusively by state armed forces
Aron, et al. 1991	No indication of frequency given	Women are more often targeted for sexual torture than men Sexual violence was part of standard operating procedures in detention facilities and during community occupations
CDHES 1986	High, 76% of detainees were sexually attacked	Seven of the 40 documented forms of torture were sexually-based offenses Sexual violence was generally perpetrated before detainees were transferred to Mariona prison
Author interviews with human rights organizations in El Salvador and the US 2011	Moderate-High	Asymmetric, most often perpetrated by state armed forces; few cases of SV perpetrated by the FMLN Occurred during military operations in rural communities Occurred during detention and interrogation procedures

**Table 7.1 Literature on Wartime Sexual Violence in El Salvador: Key Findings to Date**

The most visible, but also the most limited, report on wartime sexual violence in El Salvador was issued by the *Comisión de la Verdad para El Salvador* (CVES). As discussed in Chapter 2, the CVES did not investigate cases of sexual violence. It argued that because there was no evidence of orders or a policy of rape, such acts were apolitical,

<sup>162</sup> Data used in the study come from the US State Department country reports on human rights. These data indicate that sexual violence was infrequent during the Salvadoran civil war. However, the author goes on to argue that the true prevalence was probably greater than indicated by the data.

interpersonal violence and as such did not fall within its mandate (Hayner 2002).

Because of this executive decision, the Commission did not define the parameters of sexual violence, and made no attempt to explain these violations in the narrative of its final report. This is true even for well-known cases where sexual violence was reported. In the case of four U.S. churchwomen who were kidnapped, raped and murdered in 1980 by the *Guardia Nacional* (GN, National Guard), the Commission reported, but did not investigate the motives behind, the rapes (CVES 1993). Another publicized case involved the kidnapping, torture and murder in 1982 of four Dutch journalists. In addition to other forms of torture and physical mutilation, the victims also endured trauma to their genitals, which was not reported in the Commission's final report (Valencia-Weber and Weber 1986, Dutch Ministry of Foreign Affairs 1982). The Commission's disparate reporting suggests it had an implicit working definition of sexual violence as the rape of women.

In the annex to its final report, the CVES published a list of victims of sexual violence based on its compilation of testimonies. Where permitted, the Commission documented the individual's name, the date and location of the human rights violation, the type of violation, including rape, and the suspected perpetrator group. Of the 7,357 cases recorded, only 270 (3.7 percent) included rape (CVES 1993, 8). Not all victims were identified by name, to protect their wishes for anonymity. Based on those who were, it appears that the truth commission only identified cases of rape against women, and did not include sexual violence against men such as sexual torture. There was only one case of rape against an individual identified as male by his name.

In another independent study of wartime sexual violence in El Salvador, as well as Sierra Leone and East Timor, Dara Cohen (2010) uses the US State Department country reports on human rights to collect data on conflict-related sexual violence. According to this source, during the civil war in El Salvador, sexual violence was infrequent and limited to the context of prison torture. There were no cases of sexual violence perpetrated by the FMLN and only a few registered acts by state security agents in 1984 and again between 1986 and 1991 (Cohen 2010, 137). Using the State Department reports, the author creates an ordinal scale of the frequency of sexual violence in 71 civil conflicts between 1980 and 1999. The highest level of sexual violence recorded during the war period was a 1, indicating that “there were ‘isolated reports,’ ‘some reports,’ ‘reports,’ or ‘there continued to be reports’ of sexual violence (Cohen 2010, 51).<sup>163</sup>

Based on the sources available, many scholars have concluded that sexual violence was minimal during the Salvadoran civil war. Wood’s description of the case aptly reflects the commonly accepted account of sexual violence in El Salvador. She writes:

Sexual violence during the civil war in El Salvador...was very low in comparison to Bosnia-Herzegovina and Sierra Leone. Government soldiers and security forces *occasionally* engaged in sexual violence, including gang and multiple rapes, against *some* suspected insurgent supporters (including some men) detained in both official and secret detention sites. There are also *isolated* reports of government forces carrying out sexual violence while on operations early in the war.

(Wood 2006, 12, italics added)

---

<sup>163</sup> Cohen goes on to argue, however, that the State Department data are flawed and likely misrepresent the true prevalence of wartime sexual violence in El Salvador. She cites several infamous cases of sexual violence by the state armed forces that are not reported by the State Department, including those that occurred during the massacres at El Mozote in 1981 and of six Jesuit priests at the *Universidad Centroamericana José Simeón Cañas* (UCA, Central American University) in 1989.

However, given the inattention of investigators during the 1980s to sexually based crimes, there is good reason to examine this case in greater detail and collect additional information on sexual violence in El Salvador *before* concluding it was an infrequent occurrence.

One of the few sources of primary data that exist on wartime sexual violence in El Salvador is a report published by the non-governmental *Comisión de Derechos Humanos de El Salvador* (CDHES, Human Rights Commission of El Salvador). The report, simply titled *La Tortura Actual in El Salvador* (Current Use of Torture in El Salvador), was written by five members of the CDHES from inside the walls of *La Esperanza* men's prison (also known as Mariona) in San Salvador. Themselves imprisoned for political crimes, the CDHES investigators had unique access to the political prisoner wing and to detainees as they returned from what they referred to as "the torture chamber." The report provides a snapshot of violence against political prisoners incarcerated at Mariona between January and August 1986.

A collection of stories and testimonies from political prisoners, the report documents graphically the most common forms of torture in El Salvador. The illustrations document more than 40 of the most common forms of prisoner abuse. In addition, the report includes a registry of the 434 prisoners transferred to Mariona between January and August 1986, along with a list of the various forms of torture each experienced. The report concludes with the detailed testimonies of eight prisoners.

According to interviews with and stories written by the inmates, most incidents of torture occurred before they were transferred to Mariona, usually during the initial abduction by security forces or while being held at local bases of the PH, PN, GN or the

Army. The report concludes that 99.8 percent of detainees were subjected to torture or other cruel or inhumane treatment. Almost all prisoners suffered physical as well as psychological torture.<sup>164</sup>

Of the 40 forms of torture documented by the CDHES, seven include sexual violence. With permission from the CDHES, the original illustrations of these abuses are reproduced below.<sup>165</sup>



**Figure 7.1 Beatings to the testicles with one's closed fists, knees, or a foreign instrument (reprinted from CDHES 1986, 40)**

~~~~~

<sup>164</sup> Beyond the forms of physical violence documented by the CDHES, the prison itself was a violent and abusive environment. Originally designed to hold a maximum of 800 prisoners, at the time the CDHES report was published, there were approximately 2,600 inmates at Mariona. Half of these were held in the wing designated for political prisoners (UNHCR 2001). Overcrowding of this magnitude inevitably results in substandard living conditions.

<sup>165</sup> These images are included as they represent the illustrated testimony of victims and survivors of violence. While graphic in nature, they serve as documentary evidence of abuse in the same way as victims' oral or written testimonies.

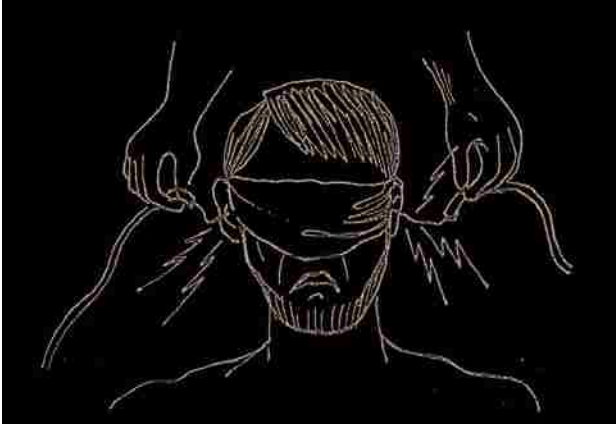

Figure 7.2 Electric shock applied to various parts of the body, including the ears, nipples, tongue, penis, anus, and feet (reprinted from CDHES 1986, 43)

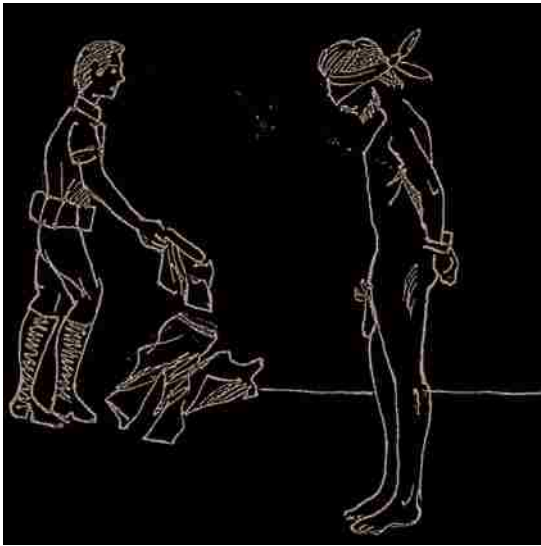
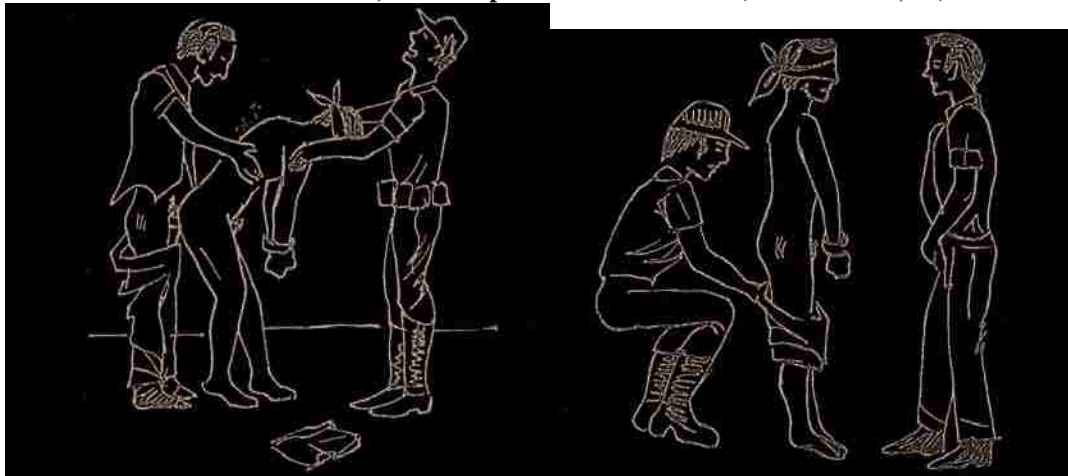

Figure 7.3 Forced nudity, a state of complete helplessness in which the prisoner may be subjected to sexual harassment or humiliation, and is exposed to the elements (CDHES 1986, 45)



Figures 7.4 and 7.5 Rape and threats of rape (reprinted from CDHES 1986, 46)





definition of sexual violence as rape would dramatically misrepresent the nature of sexual abuse against detainees at Mariona prison.

In one case, GN agents in uniform and civilian clothes broke into Alejandro's\* house in Santa Ana and detained him, accusing him of being a commander of the FPL and committing crimes against "la Personalidad Jurídica del Estado." They took him to the Central Base of the GN in San Salvador. The next morning they began to interrogate him. They said he was in charge of distributing weapons to the various fronts in the war. He denied their accusations. They stripped him and began to pull on his penis. One of them said "[d]on't bother with this motherfucker, we already know everything we need to know. We have been following you for 5 years." (CDHES 1986, 102). They began to beat him all over his body. He was blindfolded and had his hands tied behind his back. They began to submerge him in a bathtub of water, demanding he confess to his crimes. After repeated water torture, he lost consciousness and the interrogation stopped. The next day the torture and interrogation began again. They shocked him with 320 volts of electricity on his tongue and he passed out. After reviving him, they shocked him again, this time on his penis and anus.

In his testimony, Alejandro stated that unlike others in the community who were also detained, but who were targeted simply because they lived in La Palma, he was targeted individually for the worst forms of torture because the authorities suspected him of being a guerrilla commander. He describes that these tortures were designed to destroy him. According to Alejandro, it was working. After only two days of detention

---

\* All names are replaced to protect the identity of witnesses and victims of violence.

and torture at the GN base, he began to lose track of time; he began to lose his mind and would have said anything for them to stop the abuse (CDHES 1986, 102-109).

While the report itself is unique, the finding that many men are subjected to sexual violence while detained in state-run prisons and military bases is not. Multiple scholars and human rights experts in El Salvador have confirmed that sexual torture was frequently used against both male and female political prisoners. However, it must be noted that most persons captured by the security forces and accused of political crimes never made it to Mariona prison or any other detention center in El Salvador, but rather were extrajudicially executed or simply disappeared. What forms of pre-mortem violence these individuals endured is not known.

The principal finding of the CDHES investigation – that men are frequently and systematically subjected to sexual torture during detention – is supported by dozens of human rights activists in El Salvador. Between March and April 2009, I conducted interviews with representatives of all the major human rights institutions operating in El Salvador during the civil war (see Table 7.2). Each independently conveyed the same story: *Based on my experiences, I believe that sexual violence was perpetrated frequently, however, no systematic analysis of these abuses was ever conducted.*

| <b>Institution</b>              | <b>Interview Style and Dates</b>                | <b>Comments Regarding Sexual Violence</b>                                                                                                                                                                                                                                                                                                                                   |
|---------------------------------|-------------------------------------------------|-----------------------------------------------------------------------------------------------------------------------------------------------------------------------------------------------------------------------------------------------------------------------------------------------------------------------------------------------------------------------------|
| Human Rights Watch              | Personal communications between March-July 2006 | SV is greatly underreported<br>Many women reported being raped                                                                                                                                                                                                                                                                                                              |
| CDHES                           | Personal communication April 8, 2011            | Many, many women who were detained by the military or police were forcibly stripped and raped                                                                                                                                                                                                                                                                               |
| Office of the Public Prosecutor | Personal communication March 6, 2009            | No cases of wartime sexual violence were ever prosecuted during interviewee's tenure                                                                                                                                                                                                                                                                                        |
| COMADRES                        | Personal interview March 27, 2009               | Political prisoners often talk about rape as a form of torture in detention centers; armed forces used SV as a form of punishment of those who belonged or collaborated with the FMLN<br>SV was also common during Army operations in rural communities, during which women were raped before being killed along with men<br>Army committed more SV than other institutions |

|                              |                                   |                                                                                                                                                                                                                                                                                                                                                                                                                                                                                                                                                                                                                                                                                                                                                                                                          |
|------------------------------|-----------------------------------|----------------------------------------------------------------------------------------------------------------------------------------------------------------------------------------------------------------------------------------------------------------------------------------------------------------------------------------------------------------------------------------------------------------------------------------------------------------------------------------------------------------------------------------------------------------------------------------------------------------------------------------------------------------------------------------------------------------------------------------------------------------------------------------------------------|
|                              |                                   | <p>There are a few cases of SV perpetrated by the FMLN</p> <p>Of the testimonies collected by Co-Madres, 33 percent mentioned sexual violence; of these 15 percent discussed sexual violence against men; however, these testimonies have never been systematically analyzed</p> <p>None of the human rights NGOs really talked about SV during the war, so there is no systematic investigation</p>                                                                                                                                                                                                                                                                                                                                                                                                     |
| Melidas                      | Personal interview March 24, 2009 | Most SV was perpetrated by state armed forces, but there was also SV within the FMLN                                                                                                                                                                                                                                                                                                                                                                                                                                                                                                                                                                                                                                                                                                                     |
| ORMUSA                       | Personal interview March 24, 2009 | <p>Truth Commission had no gender focus</p> <p>There were limited investigations by NGOs on gender-based violence during war because of a lack of political will and fear amongst women to come forward</p> <p>Most SV was perpetrated by state armed forces, but there are also cases perpetrated by FMLN</p> <p>FMLN claims there was only ever 1 case of SV by one of its members; the perpetrator was subsequently executed</p>                                                                                                                                                                                                                                                                                                                                                                      |
| Tutela Legal del Arzobispado | Personal interview March 25, 2009 | <p>There were many victims of SV during community massacres in rural zones; these cases were often perpetrated by the Atlacatl Battalion</p> <p>There were many cases of SV in the communities located in proximity to military bases; the military dominated the area; in these cases, SV wasn't politically motivated; soldiers raped because they could do whatever they wanted</p> <p>There were also many cases reported of women being raped while held in detention facilities, especially women who were suspected of being guerrillas</p> <p>There were a few cases of SV perpetrated by the FMLN, but the perpetrators were quickly disciplined</p> <p>Huge reluctance of women to speak about SV</p> <p>There were no social or medical resources available at the time for victims of SV</p> |
| Socorro Jurídico Cristiano   | Personal interview April 29, 2009 | <p>Sexual violence was systematic during the war, but there was never a separate treatment of these crimes in SJC investigations</p> <p>SV occurred alongside other forms of torture against political prisoners, during massacres, especially in the first year of the war; the majority of those killed were raped before being assassinated.</p> <p>Forced nudity was pervasive throughout the process of being captured and detained; women, children and men were stripped, groped and insulted in sexually explicit ways</p>                                                                                                                                                                                                                                                                       |
| IDHUCA                       | Personal interview March 26, 2009 | <p>Violence against women during the war was completely invisible; the Truth Commission did not investigate gender-based crimes</p> <p>Lack of political will to investigate violence against</p>                                                                                                                                                                                                                                                                                                                                                                                                                                                                                                                                                                                                        |

|        |                                   |                                                                                                                                                                                                                           |
|--------|-----------------------------------|---------------------------------------------------------------------------------------------------------------------------------------------------------------------------------------------------------------------------|
|        |                                   | women<br>When women report violence, they are re-victimized by judicial system that does not believe their accusations, blames them for the violence, and refuses to prosecute offenders                                  |
| FESPAD | Personal interview March 27, 2009 | Did not receive testimonies of SV during the war, but heard of many cases 3 <sup>rd</sup> person<br>There were no human rights NGOs documenting SV during the war; the topic was not implanted in El Salvador at the time |

**Table 7.2 Interviews with Governmental and Non-Governmental Institutions in El Salvador**

Similarly, interviews conducted by other scholars with members of the human rights community and former combatants support the view that sexual violence was a frequent occurrence. According to interviews conducted by Elvan Isikozlu and Ananda S. Millard, nearly all women that were detained by the armed forces were raped (2009).

### **Data Collection and Procedures**

Data used in this study were collected over the course of 10 months from the archived records of Tutela Legal del Arzobispado and Socorro Jurídico Cristiano. Each record represents the testimony of a victim, witness or their loved ones. In addition to demographic data on the interviewer, the deponent, and any victims or perpetrators of violence mentioned, each file also includes a qualitative description of the event(s) being reported. These narratives are generally less than 1 page in length, but can be as long as 10 pages. I read all of the testimonies collected by Tutela Legal and all of those collected by SJC before 1984 (approximately 8,000 testimonies in total).<sup>168</sup>

Using these records, I created a new dataset on state-perpetrated sexual and other forms of political violence during the Salvadoran civil war (1978-1992). In it, I recorded

---

<sup>168</sup> Socorro Jurídico Cristiano is the only non-governmental human rights organization that was collecting testimonies and carrying out investigations of human rights violations during the early years of the war *and* whose records have been preserved. However, in 1982 Tutela Legal replaced SJC as the human rights institution of the Archdiocese. While SJC continued to conduct its own investigations independent from the Archdiocese, Tutela Legal became the leading non-governmental human rights organization after that time. Because the work of SJC and Tutela Legal is complimentary, I relied on SJC only for information on violent events that occurred before 1984.

information on cases of detention, disappearance, extrajudicial execution, battle-related deaths, injury, forced recruitment, kidnapping, torture and multiple forms of sexual violence, including rape and gang rape, sexual torture, sexual mutilation, sexual humiliation, sexual coercion, forced abortion, forced impregnation, sexual slavery, and a general category for unspecified forms of sexual violence.

The contemporaneous nature of the data (discussed in Chapter 3), coupled with limited or no access to state-run detention facilities, results in missing data on particular *types* of violence – torture, sexual violence and extrajudicial execution.<sup>169</sup> In the sections below, I present the data as reported to Tutela Legal and SJC. I note those figures that are most likely to be affected by the contemporaneous nature of the data collection procedures and thus should be interpreted with caution.

### **Repertoires of State Violence during the Civil War in El Salvador**

The records of Tutela Legal and Socorro Jurídico document 11,091 human rights violations perpetrated by state security agents in El Salvador between 1975 and 1993. According to their files, the most frequent forms of state violence were kidnappings and arbitrary detention (20 and 47 percent, respectively), torture (14 percent), massacres (8 percent) and forced disappearances (5 percent). Figure 7.7 below presents the relative frequency of all reported human rights violations perpetrated by state armed forces during the war.

As indicated above, some forms of violence will *appear* to be more (or less) frequent as a result of the data collection process and *not* because they actually occurred

---

<sup>169</sup> Forced disappearances were coded very conservatively, such that there is a high degree of confidence that those incidents recorded as disappearances do, in fact, satisfy the definition (see Appendix D). A case was only coded as a disappearance if the deponent mentioned that efforts made to locate the person abducted had failed or if the testimony specifically mentioned that the person was never seen again. Otherwise, only the initial capture was recorded (as either an arbitrary detention or kidnapping).

at a higher (or lesser) rate than other types of violence. For example, the data indicate that lethal violence comprised only 16 percent of all violence during the civil war.

However, there is ample evidence from the secondary literature, CVES' analyses and multiple forensic investigations that death squad style killings and large-scale massacres were not uncommon during the war, particularly between 1978 and 1983.

Persons who were killed by the state during the civil war were significantly more likely to be extrajudicially executed than to be killed on the battlefield. Those who were extrajudicially executed were four times more likely to be killed during a massacre of five or more victims than to be killed alone. It is less likely that these patterns – that most lethal violence occurred off of the battlefield and during large-scale violent events – are affected by the contemporaneous nature of the data.

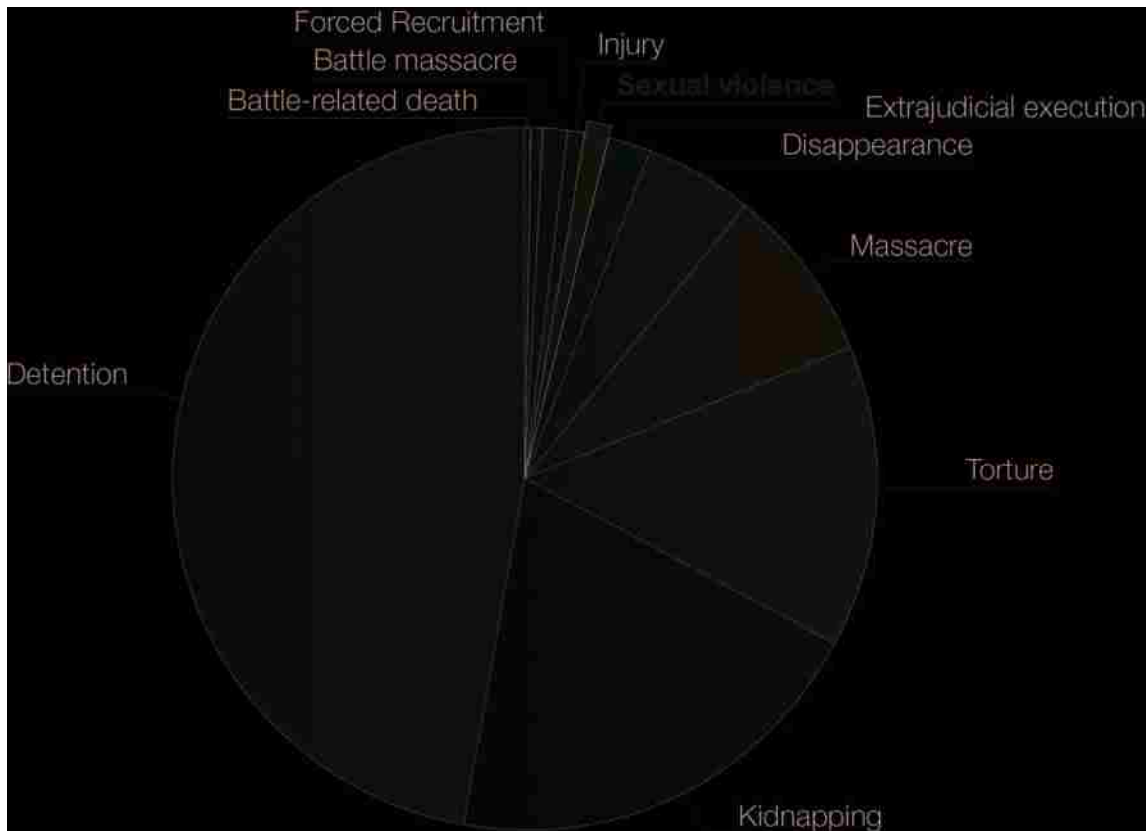

**Figure 7.7 State-Perpetrated Political Violence in El Salvador, 1978-1992**

Most state violence occurred between 1982 and 1989 in the central and northeastern regions of the country (see Figure 4.8 below). According to reporting patterns, most violence occurred in San Salvador (47 percent), La Libertad (10 percent), Chalatenango (7 percent) and Morazán (6 percent) in 1982 (14 percent), 1983 (9 percent), 1986 (9 percent) and 1989 (12 percent).

That almost half of all conflict-related violence occurred in San Salvador is almost certainly driven by the reporting patterns of victims and the data collection techniques employed by Tutela Legal and SJC, and is not representative of the true patterns of violence during the civil war. Victims who live in severely war torn regions may deem it too dangerous to travel to a local human rights office or to be seen speaking with foreign investigators, journalists or human rights activists, presuming that such



investigators are even able to travel and work in these areas. Because of the fluidity of battle lines in civil wars and the targeting of those attempting to document and report on war-related events, investigators often find themselves at similar risk as the populations they are aiding. In El Salvador, the state carried out an explicit campaign of repression against journalists. The *Comité de Prensa de las Fuerzas Armadas de El Salvador* (COPREFA, Armed Forces' Press Office) repeatedly threatened those who "distorted" or "tarnished" the image of the government and armed forces with "drastic measures." The names of journalists and human rights activists figured prominently on death squad "hit lists" in the early 1980s (Valencia-Weber and Weber, 1986). Indicative of this climate of violence and fear, the armed forces required Tutela Legal's investigators to sign waivers of responsibility for their physical safety while operating in contested regions of the country. As a result, both Tutela Legal and SJC often limited their investigations to urban areas where violence was less widespread (González 2009).

That Morazán figures prominently in the level of political violence is not surprising given that the area was considered a rebel stronghold and that state security agents assumed those living in the area were either members of the FMLN or supported them.

Beyond political geography, important insights into the motivations and causes of state violence can be drawn from the precise location and context in which it occurs. Most human rights violations occurred outside of state-run detention facilities and were not committed in an attempt to obtain "actionable intelligence" on the opposition. Among the most common sites of state violence were the victim's home, the street, or other unspecified locations in the community where the victim lived or resided. These

results reflect the disproportionate number of kidnappings in the database (20 percent). Often people were captured from their homes or abducted off of the streets by armed men in civilian clothes.

Sexual violence comprised about 1 percent of all state-perpetrated human rights violations reported to Tutela Legal and SJC. The overall number of sexual violations (126) is likely underreported (see Chapter 2).<sup>170</sup> The proportion of human rights abuses that were sexual in nature is also likely underreported due to Tutela Legal and SJC's data collection process. As illustrated by Figure 7.8, the most commonly reported types of state-perpetrated sexual violence are as follows: sexual humiliation (44 percent), sexual torture (18 percent), rape (18 percent), attempted and threatened acts of sexual violence (12 percent), gang rape (6 percent) and sexual mutilation (2 percent). Despite anecdotal evidence of soldiers sometimes killing pregnant women by cutting open their stomachs and forcibly removing their fetuses, there are no cases of forced abortion reported by Tutela Legal and SJC.<sup>171</sup> To the extent that forced abortion occurred during community massacres, as was reported by Amnesty International, it is possible that these crimes are absent from the database because of the reporting procedures of Tutela Legal and SJC. For the most part, however, it is not likely that the reporting of different forms of sexual violence is dramatically affected by the data collection process of Tutela Legal and SJC.

---

<sup>170</sup> Limiting sexual violence to those violations recognized as war crimes by the ICC, sexual violence comprised less than 1 percent of all state violence (compared to 1 percent of all state violence when employing a broad definition of sexual violence). There were 55 total violations recognized by the ICC recorded in the database.

<sup>171</sup> See Amnesty International reports on El Salvador in 1982 and 1991.



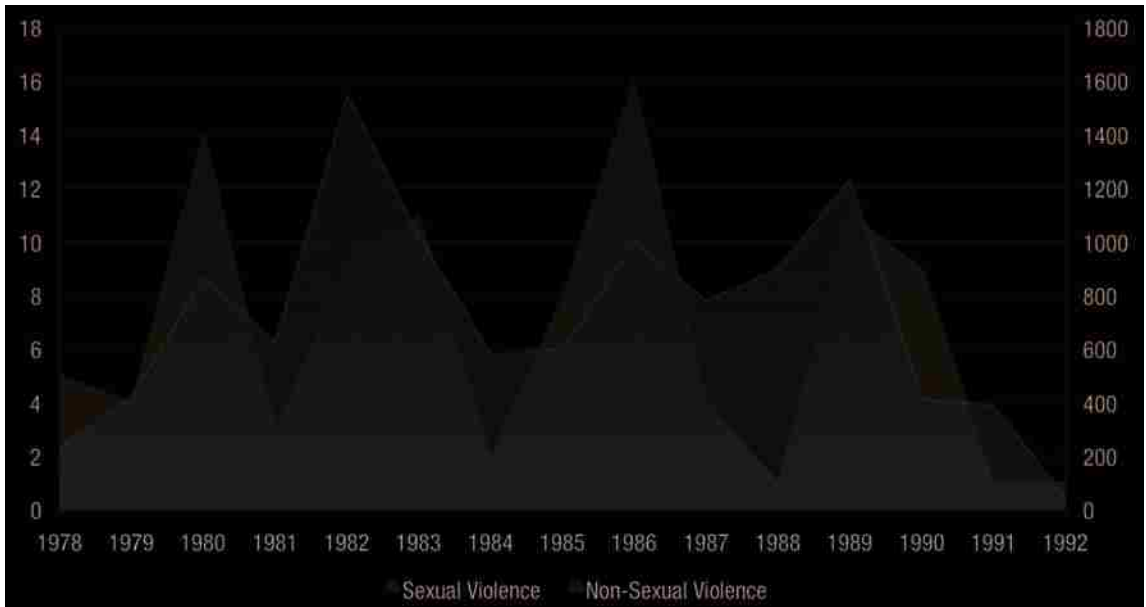

**Figure 7.9 State-Perpetrated Sexual and Other Forms of Political Violence in El Salvador, 1978-1992**

Sexual violence occurred in different departments than other forms of political violence (Pearson  $\chi^2(13) = 32.5744, p < 0.01$ ). Given the levels of other forms of violence in each department, sexual violence was more frequent than expected in Cuscatlán, San Vicente and Santa Ana. Additionally, sexual violence occurred in different *spaces* than non-sexual forms of political violence (Pearson  $\chi^2(10) = 360.0629, p < 0.001$ ).<sup>173</sup>

Unlike other forms of political violence, sexual violence was largely committed in private spaces where it is less likely that the crime would be witnessed by a third party, often on the victim’s farm or in a crop field. In fact, violent events that included some form of sexual violence were less likely than those that did not to be witnessed by a third party (Pearson  $\chi^2(1) = 4.6833, p < 0.05$ ). Sexual violence was most often perpetrated in state-run detention facilities (48 percent), private residences and farms, most often the

<sup>173</sup> According to ICC parameters, Cuscatlán is the only department in which the state perpetrated more sexual violence than expected given rates of other forms of state repression.

victim's own property (33 percent). More frequently than expected, sexual violence was perpetrated in state-run detention facilities (Pearson  $\chi^2(1) = 391.1173$ ,  $p < 0.001$ ).

| <b>ALL SEXUAL VIOLENCE (INCLUDING SEXUAL HUMILIATION AND COERCION)</b>                                                  |                  | <b>SEXUAL VIOLENCE ACCORDING TO THE ICC</b>                                                          |                  |
|-------------------------------------------------------------------------------------------------------------------------|------------------|------------------------------------------------------------------------------------------------------|------------------|
| 99 cases of SV, 1% of state violence<br>126 individual sexual violations                                                |                  | 53 cases of SV, less than 1% of state violence<br>55 individual sexual violations                    |                  |
| <b>Types of Sexual Violence</b>                                                                                         |                  |                                                                                                      |                  |
| Rape 18%<br>Gang rape 6%<br>Sexual humiliation 44%<br>Sexual torture 18%<br>Sexual mutilation 2%<br>Sexual coercion 12% |                  | Rape 42%<br>Gang rape 13%<br>Sexual torture 42%<br>Sexual mutilation 4%                              |                  |
| <b>Sexual Violence by Department</b>                                                                                    |                  |                                                                                                      |                  |
| Ahuachapán 1%                                                                                                           | Morazán 6%       | Ahuachapán 0                                                                                         | Morazán 8%       |
| Cabañas 1%                                                                                                              | San Miguel 1%    | Cabañas 2%                                                                                           | San Miguel 2%    |
| Chalatenango 2%                                                                                                         | San Salvador 44% | Chalatenango 2%                                                                                      | San Salvador 45% |
| Cuscatlán 10%                                                                                                           | San Vicente 10%  | Cuscatlán 12%                                                                                        | San Vicente 12%  |
| La Libertad 6%                                                                                                          | Santa Ana 9%     | La Libertad 2%                                                                                       | Santa Ana 8%     |
| La Paz 6%                                                                                                               | Sonsonate 0      | La Paz 4%                                                                                            | Sonsonate 0      |
| La Unión 2%                                                                                                             | Usulután 1%      | La Unión 4%                                                                                          | Usulután 0       |
| <b>Sexual Violence by Location</b>                                                                                      |                  |                                                                                                      |                  |
| Sexual violence most frequently occurred on the victim's farm and in state-run detention facilities.                    |                  | Sexual violence most frequently occurred on the victim's farm and in state-run detention facilities. |                  |

**Table 7.3 State-Perpetrated Sexual Violence, All Sexual Violations and ICC Violations Compared**

### **Victim Profile**

In this section, I will describe the general profile of a victim of state violence during the Salvadoran civil war, and then consider the ways in which victims of sexual violence differed from this broader population. Included in the database are 8,518 unique victims of violence, each of whom suffered at least one violation of their human rights. Most victims experienced a single form of violence (78 percent).<sup>174</sup> Twenty-one percent experienced two or three forms of violence. Eleven percent of victims reported having previously been the victims of human rights abuse or knowing someone who was. Because the reports of Tutela Legal and SJC do not reflect complete histories of an individual's conflict experiences, these figures are likely underreported. In other words,

<sup>174</sup> Without complete conflict histories, this figure is likely over-reported.

the average number of violations per victim is likely greater than one and it is very likely that more than 11 percent of victims had previously been targeted for violence or knew someone who was.

Most victims of state repression during the Salvadoran civil war were young, single men.<sup>175</sup> For those whose occupation was recorded (62 percent of all victims in the database), the most commonly reported jobs were: peasants and farmers (27 percent), laborers, such as construction workers or bricklayers (28 percent), university students and teachers (17 percent) and semi-skilled light industry workers, such as shoemakers or bakers (12 percent).

The vast majority of victims in the database did not report belonging to any social, religious or political organizations. Given the politicization of these organizations, many of which were equated in the media with the armed opposition, this could reflect a deliberate decision on the part of the deponent to protect the victim from further discrimination or violence. Particularly because the data was collected as the conflict unfolded, individuals had a strong incentive to portray themselves or their loved ones as entirely apolitical and unorganized.

---

<sup>175</sup> Based on victim self-reporting, gender is coded as a dichotomous variable.

EL MUNDO 30 DE JULIO DE 1988 16

**GUERRA POPULAR, MINA POPULAR  
PARO POPULAR, APAGON POPULAR = DOLOR POPULAR  
TERROR POPULAR**



**EL FMLN-FDR QUIERE SUMIR AL PUEBLO SALVADOREÑO  
EN LA OSCURIDAD**  
COMADRES, UNTS, FECMAFAM, CRIPDES, AGEUS  
FEUS, Y OTROS GRUPOS DE FACHADA

¿POR QUE NO SE PRONUNCIAN CONTRA ESTAS VIOLACIONES  
TERRORISTAS DE LOS DERECHOS HUMANOS?

**¡SU SILENCIO LOS DELATA!**



YO SOY UNA DE SUS VICTIMAS  
NO DEJES QUE ELLOS TE UTILICEN,  
NO DEJES QUE TE CONVIERTAN EN  
VICTIMA DE SUS PROPOSITOS  
HOMICIDAS.

ESTE 30 DE JULIO

**¡QUE NO TE ENGANCHEN!**

1988-07-30 16:17:00

Figure 7.10 Ad placed by COPREFA in the Salvadoran daily, *El Mundo* July 30, 1988. The title reads: “The People’s War, People’s Mine, People’s Strike, People’s Blackout = The People’s Pain and Terror.” The caption on the left reads: “The FMLN-FDR want to plunge the Salvadoran people into darkness. COMADRES, UNTS, FECMAFAM, CRIPDES, AGEUS, FEUS, and others are front groups for the FMLN. Why don’t they denounce the terrorists’ violations of human rights? Their silence is a crime!” The caption on the right reads: “I am one of your victims. Do not let them use you. Do not let them make you a victim of their killing. June 30, 1988. Don’t let them hook you!” (COPREFA 1988, 16-17, author translation).

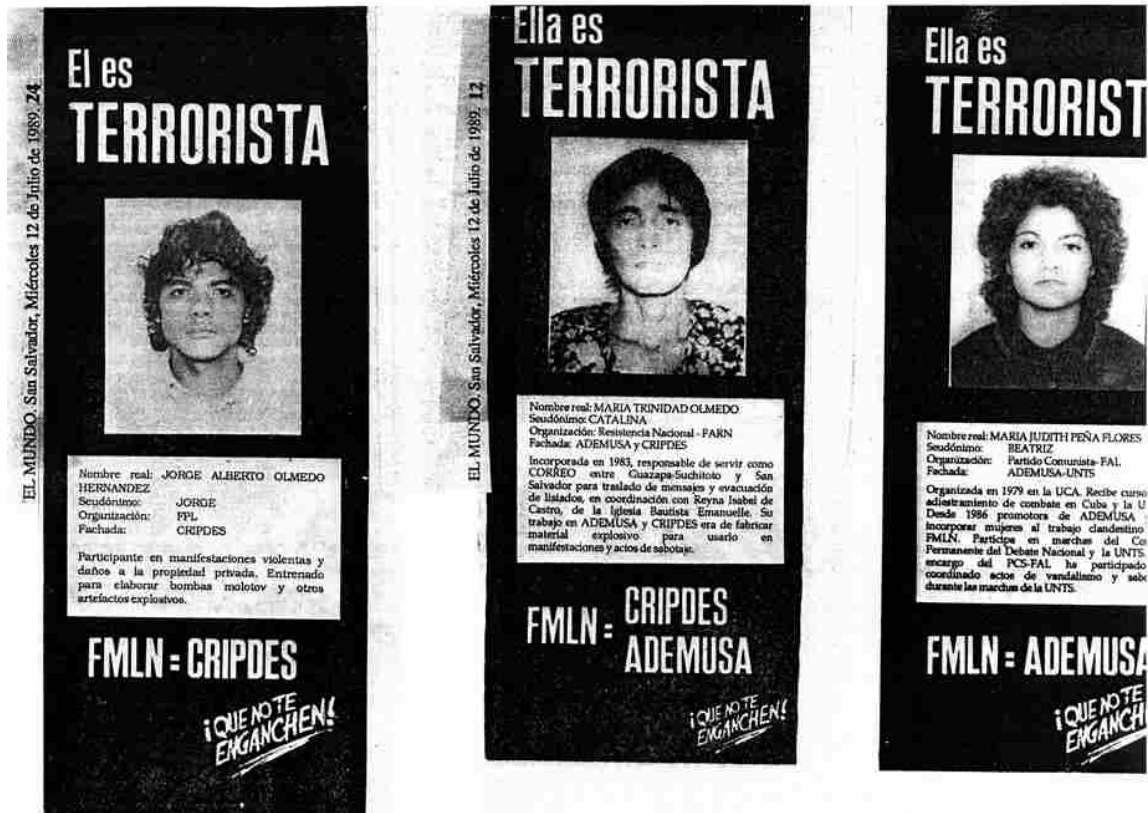

Figure 7.11 Ad placed by the National Information Services in the Salvadoran daily, *El Mundo* on July 12, 1989. It accuses three persons of being terrorists and members of the FMLN. Moreover, it equates CRIPDES, ADEMUSA and UNTS with the FMLN.

Pamphlets like the ones shown below (Figures 7.12-7.13) were frequently dropped from planes and helicopters, blanketing the communities below.





Figure 7.12 Salvadoran People: UNTS leads its members to death by being a front organization that serves the FMLN and DRU [Unified Revolutionary Directorate] Communist Party. Julio Cesar Portillo Reyes, Leader of UNTS and member of the FMLN. Everyone must denounce the enemies of our Fatherland!



Figure 7.13 UNTS is the political-military base of the FMLN. Marco Tulio Lima, Leader of UNTS, Member of the FMLN. Humberto Centeno, Leader of UNTS, Member of the FMLN. Guillermo Rojas, Leader of UNTS, Member of the FMLN. They have betrayed the ideals of the Salvadoran Worker.

Of those who did report belonging to a social or political organization, most were members of labor unions (44 percent), followed by members of campesino organizations or agricultural cooperatives (20 percent), religious organizations (12 percent) and human

rights groups (19 percent). While 53 percent of all victims in the database were *accused* of being armed subversives, only 27 percent of victims actually reported being a member of the FMLN, ERP, FPL or other armed rebel group.<sup>176</sup>

Victims of sexual violence differed from victims of other human rights violations in substantively meaningful and statistically significant ways (see Figures 7.14-7.18 for a complete profile of victims of sexual and other forms of political violence in El Salvador). There are 96 victims of state-perpetrated sexual violence in the dataset, 44 percent of whom are women and 56 percent are men. Similar to other forms of political violence, most victims of sexual violence were young and unmarried. There was no statistically significant difference between victims of sexual violence and victims of other forms of political violence regarding whether they had previously been targeted for abuse. This is not surprising as this variable depends heavily on having complete information on an individual's entire war experience. However, victims of sexual violence were two times more likely to know someone who was previously the victim of political violence, whether a member of their family, a friend or a loved one (Pearson  $\chi^2(1) = 13.9947, p < 0.001$ ).

While there were more male victims of sexual violence registered in the database, when targeted for violence (and therefore entering the database), women were almost four times more likely than men to be subjected to sexual forms of violence by state security agents (Pearson  $\chi^2(1) = 35.1785, p < 0.001$ ). That is, given the probability of being victimized, women are four times more likely to be victimized in ways that were sexually explicit than are men. This finding supports those of surveys done with

---

<sup>176</sup> Because subversive groups are covert and illicit by their very nature, there are strong incentives for individuals to deny their membership in such organizations.

Salvadoran refugees. For instance, in a study of Salvadoran refugees living in the Los Angeles area, it was found that women were 10-20 times more likely than men to report sexual assault as part of the torture they suffered (Aron et al. 1991). However, this finding cautions against the conclusion of some scholars that men are not subjected to attacks on their gender or sexuality (Hollander 1996).

Moreover, men and women were targeted for different forms of sexual violence. The most common forms of sexual violence against women were: rape and gang rape (51 percent), sexual humiliation (28 percent), sexual coercion (13 percent) and sexual torture and mutilation (4 percent each). The most common forms of sexual violence against men were: sexual humiliation (55 percent), sexual torture (25 percent), sexual coercion (13 percent) and rape and gang rape (7 percent).<sup>177</sup>

The employment record of victims of sexual violence is divided and reflects the urban and rural settings of the two principal patterns of sexual violence (discussed in greater detail below). Victims of sexual violence most often worked as teachers and university students (25 percent), peasants and rural day laborers (26 percent) and housewives (23 percent). Given the gendered nature of sexual violence, it is not surprising that housewives are more likely to be targeted for this form of violence than other forms of state repression (Pearson  $\chi^2(1) = 44.3762$ ,  $p < 0.001$ ). In addition, university students were two times more likely than those not attending college to be the victim of sexual violence (Pearson  $\chi^2(1) = 3.5639$ ,  $p = 0.05$ ).

Most victims of sexual violence do not report belonging to any social or political organization. For the 27 percent of victims of sexual violence whose organizational affiliation(s) is known, most are members of labor unions (19 percent), agricultural

---

<sup>177</sup> There is only one case of gang rape perpetrated against a man.

cooperatives (15 percent) or human rights organizations (19 percent). While an additional 27 percent of victims of sexual violence report belonging to armed rebel groups, 81 percent were accused of such memberships by their captors.

Members of the CDHES, Co-Madres, Christian Committee for the Displaced of El Salvador or other similar human rights advocacy groups were five times more likely than those not affiliated with such groups to be targeted for sexual violence (Pearson  $\chi^2(1) = 9.6676$ ,  $p < 0.01$ ). Members of political parties, particularly center-left parties such as *Cambio Democrático*, were eight times more likely to be targeted for sexual violence than those not associated with any political party (Pearson  $\chi^2(1) = 13.3201$ ,  $p = 0.001$ ).

Given the rate at which university students were targeted for sexual violence, it is not surprising that those who reported being a member of a student-based organization were more likely to be the victim of sexual violence than those who were not members of student groups (Pearson  $\chi^2(1) = 12.5541$ ,  $p < 0.001$ ). The *Federación de Estudiantes Universitarios Salvadoreños* (AGEUS, General Association of Salvadoran University Students) and the *Movimiento Estudiantil Revolucionario Salvadoreño* (MERS, Revolutionary Students' Movement of El Salvador) were frequently targeted for sexual violence.

Lastly, individuals who identified as members of an armed rebel organization were statistically more likely to be specifically targeted by the state for sexual violence than those who did not report belonging to the FMLN or one of its subsidiary or affiliated groups (Pearson  $\chi^2(1) = 9.5862$ ,  $p < 0.01$ ).



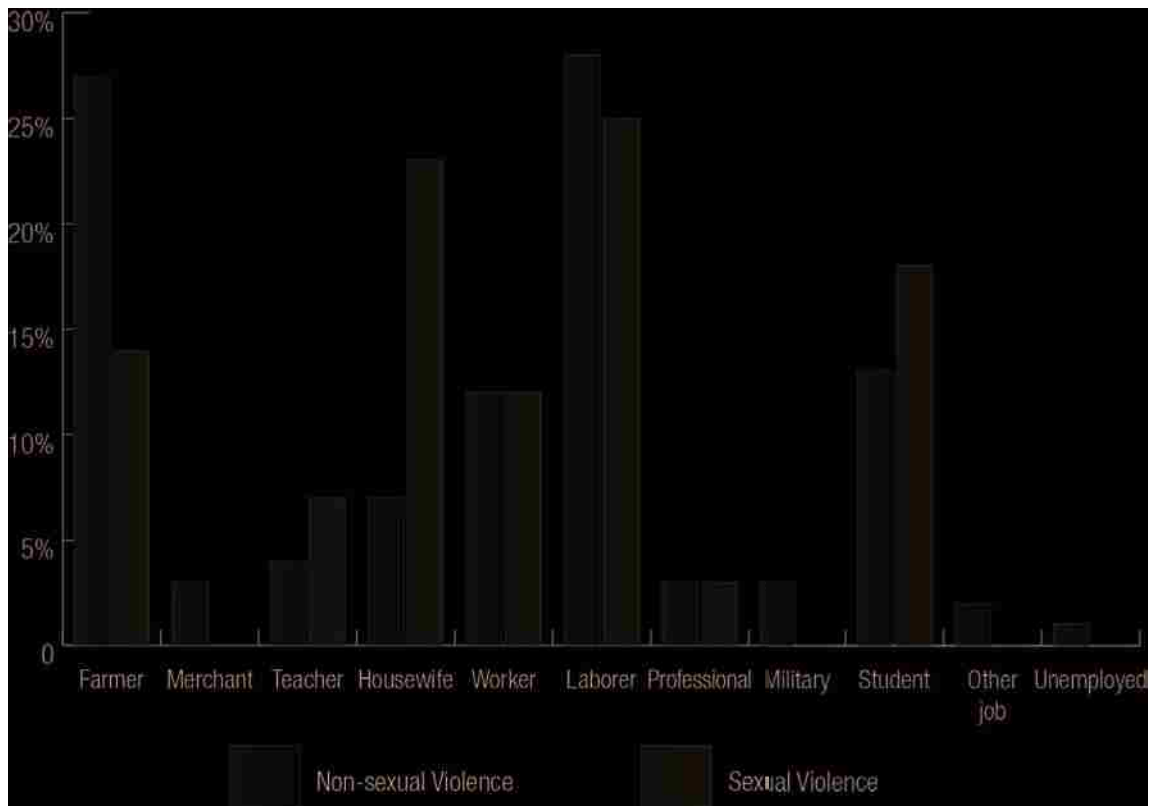
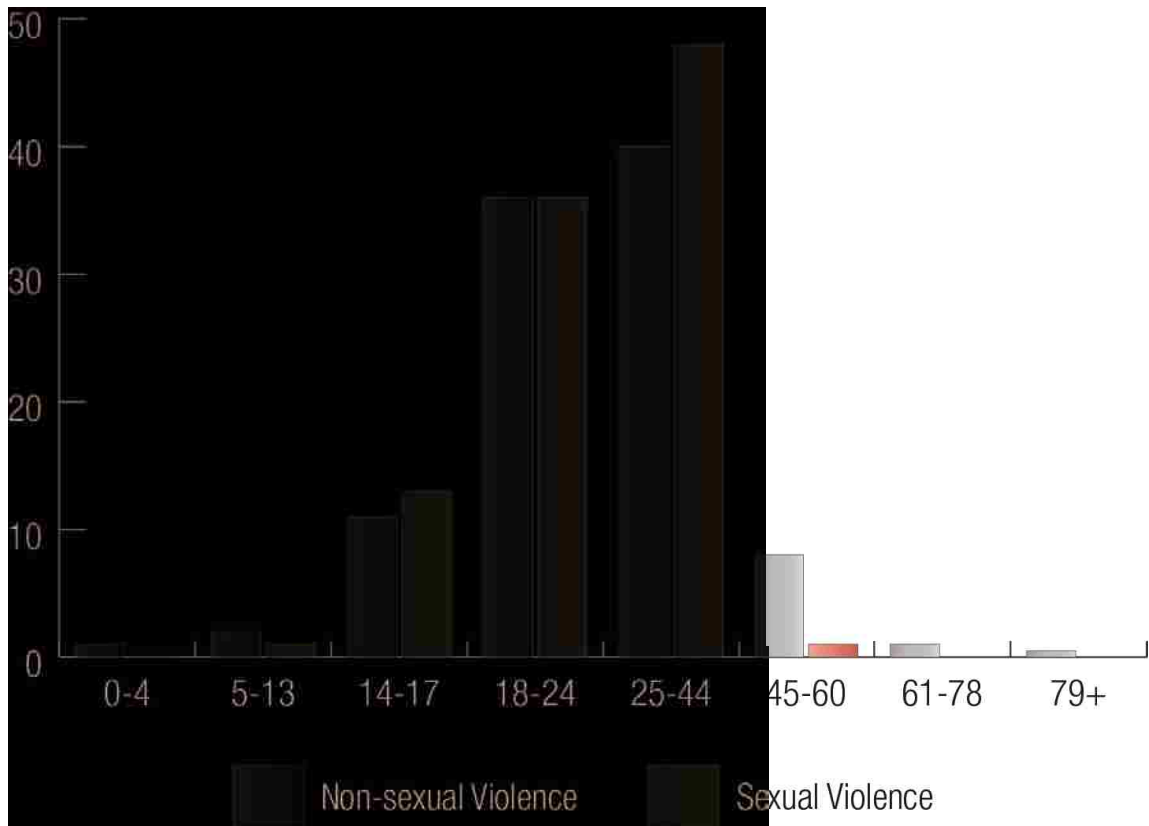

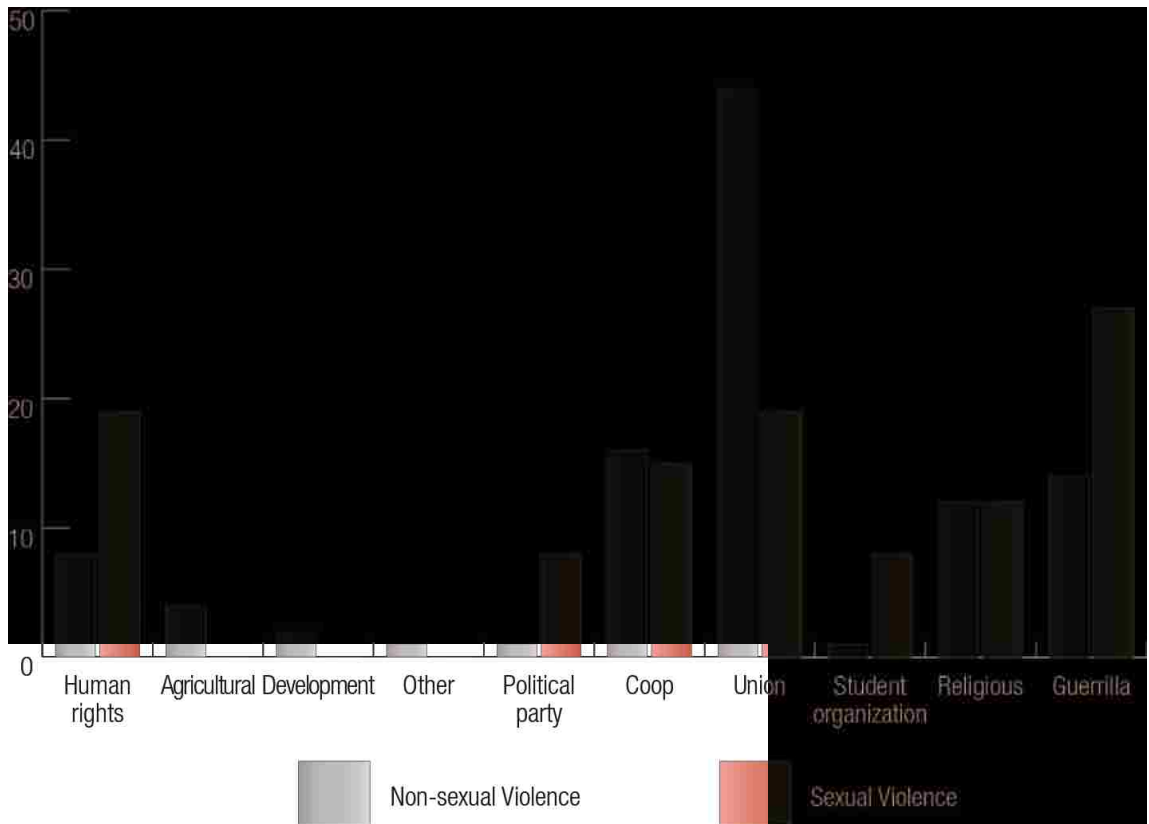

**Figures 7.14-7.18 Profile of Victims of State-Perpetrated Sexual and Other Forms of Political Violence**

In comparison to the general population of El Salvador, particular identities were more likely to be targeted for political violence. Even in comparison to victims of political violence, it was only a specific subgroup(s) of the victim population who were specifically targeted for *sexual* violence. These findings call into question the viability of the opportunity model of wartime sexual violence. If sexual violence were purely motivated by the private interests of individual soldiers or security officers, there would be no observable patterns of targeting individuals according to their social or political identities.

| ALL SEXUAL VIOLENCE (INCLUDING SEXUAL HUMILIATION AND COERCION) | SEXUAL VIOLENCE ACCORDING TO THE ICC |
|-----------------------------------------------------------------|--------------------------------------|
| 96 unique victims of sexual violence                            | 49 unique victims of sexual violence |
| <b>Gender</b>                                                   |                                      |

|                                                                                                                                                                       |                                                                                                                                                                       |
|-----------------------------------------------------------------------------------------------------------------------------------------------------------------------|-----------------------------------------------------------------------------------------------------------------------------------------------------------------------|
| Women 44%<br>Men 56%                                                                                                                                                  | Women 57%<br>Men 43%                                                                                                                                                  |
| <b>Marital Status</b>                                                                                                                                                 |                                                                                                                                                                       |
| Single 51%<br>Married/Partnered 48%<br>Divorced 0<br>Widowed 1%                                                                                                       | Single 42%<br>Married/Partnered 55%<br>Divorced 0<br>Widowed 3%                                                                                                       |
| <b>Age</b>                                                                                                                                                            |                                                                                                                                                                       |
| 0-4 years 0<br>5-13 years 1%<br>14-17 years 13%<br>18-24 years 36%<br>25-44 years 48%<br>45-60 years 1%<br>61-78 years 0<br>79+ 0                                     | 0-4 years 0<br>5-13 years 0<br>14-17 years 17%<br>18-24 years 34%<br>25-44 years 49%<br>45-60 years 0<br>61-78 years 0<br>79+ 0                                       |
| <b>Occupation<sup>178</sup></b>                                                                                                                                       |                                                                                                                                                                       |
| Farmer 14%<br>Merchant 0<br>Teacher 7%<br>Housewife 23%<br>Worker 12%<br>Laborer 25%<br>Professional 3%<br>Armed Forces 0<br>Student 18%                              | Farmer 9%<br>Merchant 0<br>Teacher 11%<br>Housewife 31%<br>Worker 9%<br>Laborer 17%<br>Professional 0<br>Armed Forces 0<br>Student 23%                                |
| <b>Organizational Affiliations<sup>179</sup></b>                                                                                                                      |                                                                                                                                                                       |
| Human rights 19%<br>Peasant 0<br>Assistance/Development 0<br>Cooperative 15%<br>Political party 8%<br>Labor/Union 19%<br>Student 8%<br>Religious 12%<br>Guerrilla 27% | Human rights 11%<br>Peasant 0<br>Assistance/Development 0<br>Cooperative 11%<br>Political party 0<br>Labor/Union 33%<br>Student 11%<br>Religious 11%<br>Guerrilla 22% |

**Table 7.4 State-Perpetrated Sexual Violence, Victims of All Sexual Violations and Victims of ICC Violations Compared<sup>180</sup>**

### Perpetrator Profile

The Salvadoran civil war was an asymmetric conflict in which the state armed forces bear responsibility for 79 percent of all human rights violations, whereas the

<sup>178</sup> Figures may be greater than 100 percent as individual victims may report having more than one job.

<sup>179</sup> Figures may be greater than 100 percent as individual victims may report belonging to more than one social or political organization.

<sup>180</sup> The profile of victims of sexual violence does not change as dramatically as one might expect given that more than half of all sexual violations perpetrated by state security agents are not included in the ICC's definition. This is because individual victims are often subjected to more than one form of sexual violence. If any of those violations is recognized by the ICC, the victim (and his/her demographic information) would be retained in the database.



guerrilla are responsible for 21 percent of all violent events. The repertoires of violence utilized by state and non-state armed groups is significantly different (Pearson  $\chi^2(10) = 5.3003$ ,  $p < 0.001$ ).<sup>181</sup> For example, while the state was seven times more likely than the rebels to extrajudicially execute someone, the FMLN was more than 300 times more likely to kill someone during active combat than was the state. According to the data, neither the state armed forces nor the FMLN forcibly recruited members in large numbers. However, it is very likely that the data significantly underreport forced recruitment by both state and non-state actors. Of those incidents that were recorded, the state was four times more likely than non-state groups to commit forcible recruitment. In addition, the state was more than 200 times more likely to engage in acts of torture than were members of the FMLN. Figures 7.19-7.22 illustrate the full repertoires of violence for both state and non-state armed actors during the Salvadoran civil war.

---

<sup>181</sup> Formal detentions, by definition, only occur in state-run detention facilities. As a result, 100 percent of all of these violations are perpetrated by state security officials.

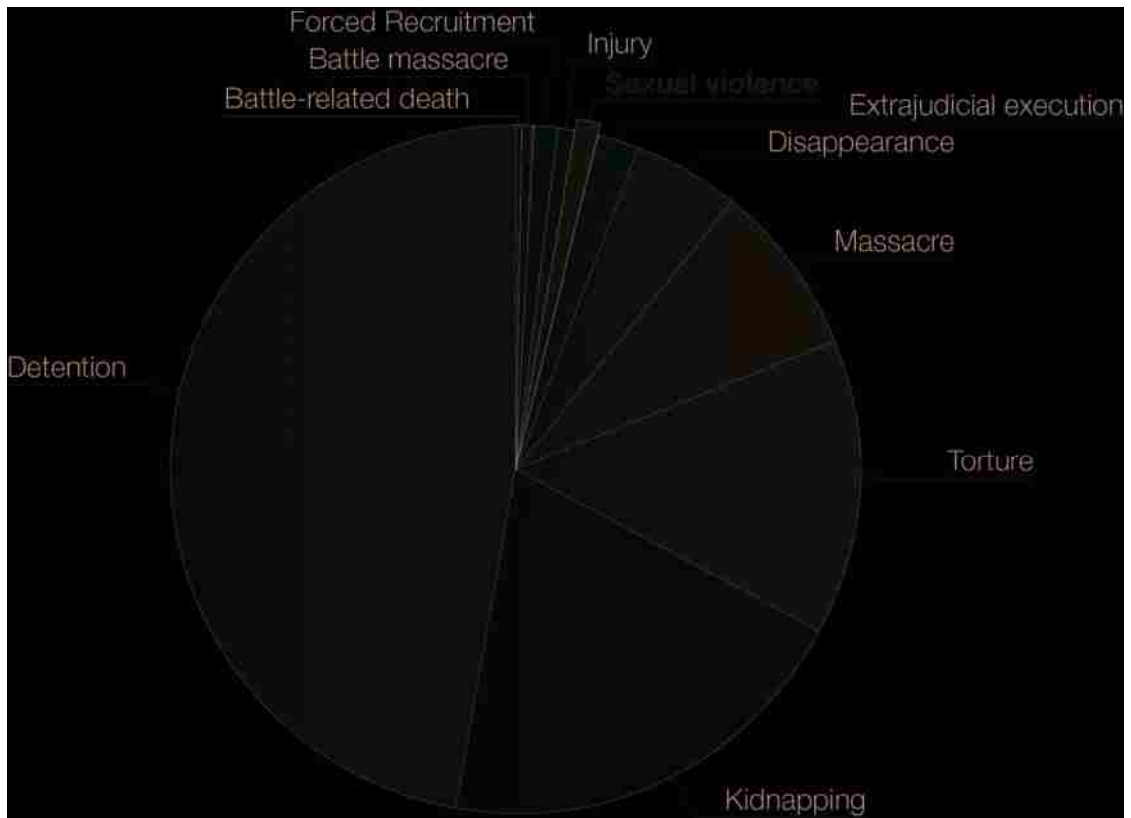

**Figure 7.19 Sexual and Other Forms of Political Violence Perpetrated by State Security Agents**

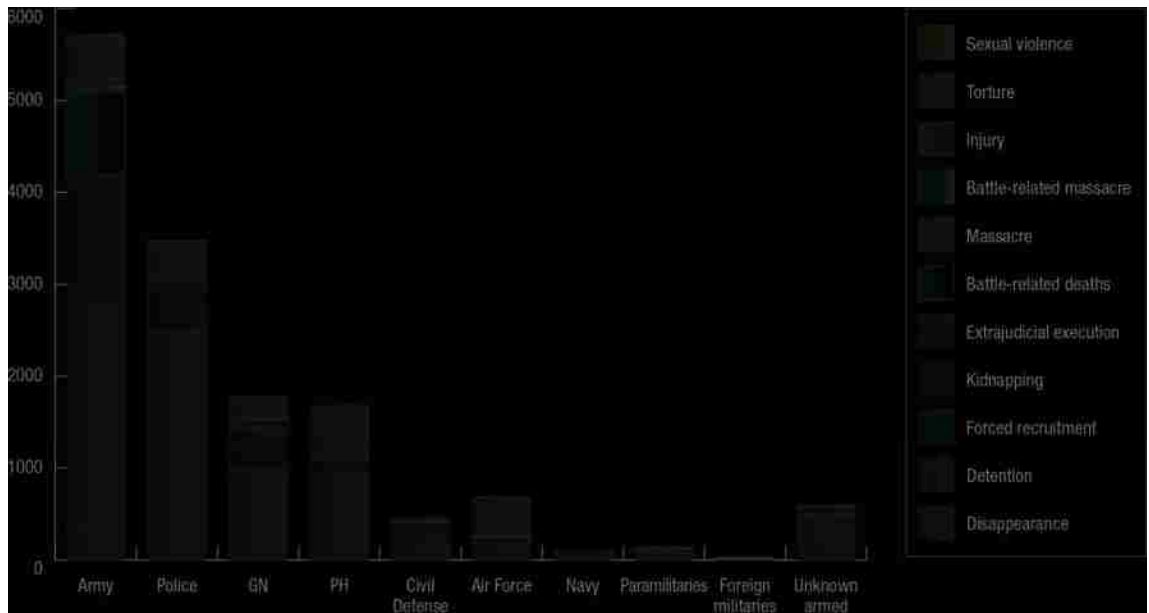

**Figure 7.20 Repertoires of State Violence by Perpetrator Group**

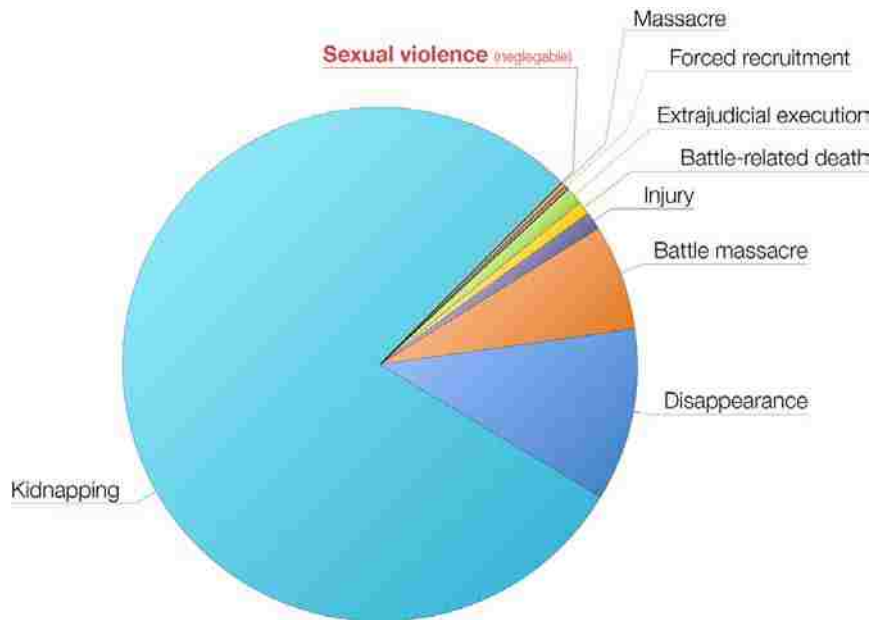

**Figure 3.21 Sexual and Other Forms of Political Violence Perpetrated by the FMLN**

While there is much uncertainty about the precise level of sexual violence during the civil war, almost all scholars and human rights investigators agree that sexual violence was virtually the sole domain of men in the state armed forces.<sup>182</sup> In their final report, the CVES documents 450 cases of sexual violence; not one of these acts was perpetrated by the FMLN. Similarly, Dara Cohen’s data on wartime sexual violence collected from the US State Department human rights reports indicates that of the few cases of reported sexual violence during the war, all were perpetrated by the state armed forces (Cohen 2010, 135-136). The data collected for this study from Tutela Legal and SJC confirm that almost all reported acts of sexual violence were committed by state security forces. In fact, the FMLN was seven times less likely to commit sexual violence than those who did not belong to the guerrilla (Pearson  $\chi^2(1) = 20.0708, p < 0.001$ ).

<sup>182</sup> The database includes only one case of sexual violence in which a female security agent participated. In this instance, a member of the agricultural cooperative in San Juan Opico, La Libertad was brought to the military base of the Artillery brigade in Berlin. He was accused of being a member of the guerrilla, interrogated and severely tortured. Frustrated at their inability to get the detainee to speak, the soldiers called a female co-worker “to assist” in the interrogation. She approached the victim, seductively stripped in front of him and promised to have sex with him if he answered her questions and told her the truth about his activities (TL 26.1.19).

According to the data from Tutela Legal and SJC, there were four incidents of sexual violence perpetrated by the FMLN. The first case, covering three of these incidents, occurred on January 9, 1988 in Cuscatlán. At five o'clock in the evening a group of guerrillas arrived in Tenancingo and captured José, Marie, Blanca, Sofia and Mario, taking them from their homes to a nearby rebel camp. The men were released three days later, but the three women were forced to serve as the combatants' girlfriends (TL 20.2.14)<sup>183</sup>.

There is a single case of the FMLN committing sexual violence perpetrated against a member of the state armed forces.<sup>184</sup> In 1983, a 22-year old soldier in the Salvadoran army was captured by guerrillas in Cuscatlán. He was driving in an army vehicle towards Suchitoto when the guerrillas ambushed him, forced him out of the truck and stripped him naked. They tied him up and marched him on foot towards the mountains (SJC 15.4.75 and 15.3.86).

Much more common were cases of sexual violence perpetrated by the state armed forces. The state armed forces committed 96 percent of all sexual abuses. The most frequent forms of sexual abuse perpetrated by the state were: sexual humiliation (44 percent), rape (18 percent) and sexual torture (18 percent). Figure 7.22 shows the frequency of reported acts of sexual violence attributed to each of the state security institutions.

---

<sup>183</sup> Because the archives of these materials are not catalogued, I assigned each testimony with a unique reference number that includes the box number in the collection, the folder number within the box, and the file number within the folder where the testimony can be found. For example, an individual interested in accessing testimony TL 20.2.14 would request box 20 from the Tutela Legal collection and look inside folder 2 for the 14<sup>th</sup> file.

<sup>184</sup> Given that the vast majority of sexual violence was perpetrated by state armed forces and that there were no recorded cases of so-called "blue on blue" sexual violence, it is not surprising that members of the armed forces were 14 times less likely than those who were not members of the armed forces to be targeted for sexual violence (Pearson  $\chi^2(1) = 12.3326, p < 0.001$ ).

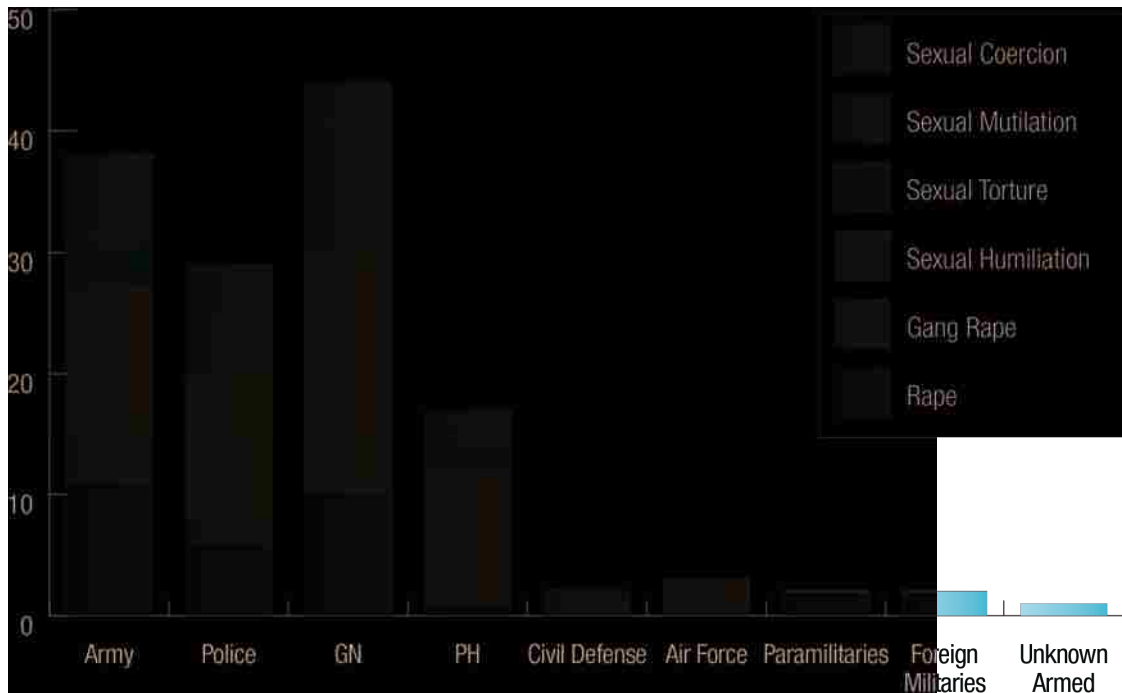

**Figure 7.22 Types of State-Perpetrated Sexual Violence by Perpetrator Group**

While I cannot say with absolute certainty, given the regularity with which state security officers did not wear military or police uniforms during operations, a clear violation of the Geneva Conventions, it is likely that most, if not all, of the perpetrators of sexual violence identified only as “unknown armed persons” were, in fact, agents of the state.

That the Army is one of the most frequently cited perpetrators of sexual violence (along with the GN) may be attributable to its sheer size. The Army is the single largest branch of the Salvadoran armed forces. With approximately 13,500 members at the beginning of the conflict, it was four times the size of the next largest sector, the GN (US Army 1981, 67). Moreover, the Army is also the single most frequently cited perpetrator of non-sexual forms of political violence, suggesting that it is simply a more violent institution and thus more likely to engage in sexual violence. In fact, given levels of violence perpetrated by soldiers, they commit less sexual violence than expected (Pearson

chi2(1) = 14.0874, p<0.001). However, the GN with only 3,600 members was three times more likely than other sectors of the state security apparatus to commit sexual violence (Pearson chi2(1) = 13.4593, p<0.001). According to declassified reports from the US Department of Defense, members of the GN were better trained and educated and better compensated for their service than the Army or other security sectors. The suggestion made by Baaz and Stern (2010) that agents who are poorly paid will exploit their position of authority and augment their inadequate incomes through theft, extortion or rape cannot explain why the GN was three times more likely than other armed groups to commit sexual violence. More importantly, regardless of the branch of the armed services, commanding officers were almost always present during the commission of sexual violence. Officers at the rank of Captain and above were six times more likely to be present during the commission of sexual violence than other acts of political violence (Pearson chi2(1) = 11.6385, p=0.001). Under the doctrine of command responsibility, the presence of commanding officers during the commission of violent acts is sufficient to establish that they knew that crimes were being committed, and thus to hold them criminally responsible.<sup>185</sup>

Of notable importance to the opportunity model of wartime sexual violence, death squads and paramilitary organizations that operated outside of the command control structure of the military infrequently engaged in sexual violence. There are only two such cases (a single event with two victims of sexual violence) recorded in the database.

---

<sup>185</sup> Key to establishing command responsibility is demonstrating that the commanding officer know, or should have known given his/her position of authority, that the abuses were occurring. During the “Hostages Case,” the Nuremberg Military Tribunals concluded that “[a]n army commander will not ordinarily be permitted to deny knowledge of...happenings within the area of his command when he is present therein. It would strain the credibility of the Tribunal to believe that a high ranking military commander would permit himself to get out of touch with current happenings in the area of his command during wartime” (XI Trials of War Criminals before the Nurnberg Military Tribunals under Control Council Law No.10 (“The Hostages Case”) 1260 (1950).

On January 19, 1983, a large contingent of combined forces of the rapid reaction Battalion Beloso of the Salvadoran army, the GN, paramilitary forces, and soldiers from the Honduran army carried out a large-scale operation in Guatajiagua, Morazán. After days of aerial bombardment, ground troops were sent in to root out the survivors. Several people were captured and executed, including Pablo, Amadeo and two unidentified women, all of whom were at a party at the time of the assault. Days later, the bodies of the two women were found in a neighboring community. Both had been raped and were shot in the head (SJC 26.1.38). Without additional information on the identity of the victims, it is difficult to determine why these women were targeted for sexual attack. In this case, it is not possible to (dis)prove either the opportunity or strategic arguments of sexual violence.

This section examined in detail the victims, perpetrators and context within which sexual and non-sexual forms of political violence occurred during the Salvadoran civil war. Sexual violence was often reserved for those individuals that were deemed “opponents of the state.” This included political opponents, armed combatants, as well as those that challenged the authority of the government or the status quo. As discussed in Chapter 3, if driven by individuals’ opportunities for violence, the profile of sexual violence (or other forms of violence for that matter) should appear random. This was not the case in El Salvador. That sexual violence is not uniformly perpetrated by all state security agencies, or members therein, suggests that something more than just opportunity is necessary to motivate the commission of sexual violence. Finally, that sexual violence is perpetrated in state-controlled detention facilities while commanding officers are present does not support the opportunity model of wartime sexual violence.

Using the narratives of survivors and witnesses of violence, the following section will outline the two qualitative patterns of sexual abuse during the Salvadoran civil war and how they lend greater credibility to the strategic model of wartime sexual violence.

### **Qualitative Patterns of Sexual Abuse by State Armed Forces**

There are two principal patterns of state-perpetrated sexual violence during the civil war in El Salvador: (1) the rape of women during massacres in rural communities before both the women and the men in the village would be killed, and (2) sexual abuse in detention facilities used to torture, dehumanize and ultimately break political prisoners and/or to collect information on the opposition's members and movements. In each section, I will discuss any evidence that supports or rejects the opportunity model of sexual violence.

#### **Sexual Violence in Rural Communities**

There is limited evidence of the first pattern from the records of Tutela Legal and SJC because often there were few or no survivors or witnesses to the attack. The most well-researched of such cases is the massacre of almost 1,000 peasants in El Mozote, a small rural community of only twenty houses in the northeastern department of Morazán during Operation Rescue in December 1981 (see Figure 7.23 below).<sup>186</sup> According to the testimony of the sole survivor of the massacre, Rufina Amaya, members of the Atlacatl battalion arrived on the night of December 10 and gathered the residents in the community plaza. The next day, the men were detained inside of the church, where they were tortured and beaten. They were later taken out in small groups and summarily executed.

---

<sup>186</sup> The death toll is for the collection of massacres carried out between December 11-13, 1981 in El Mozote and neighboring locales. On March 8, 2011, the case was referred to the Inter-American Court on Human Rights for judgment.





**Figure 7.23 El Mozote, Morazán (author photograph 2009).**

The soldiers then came for the women and children, who were being held inside a couple of houses in town. They took the young girls first. They took them to the hill, raped them and shot them. All of the women were raped before being killed (Anonymous 2009, Amaya, Danner 1994, Tutela Legal 2008).



**Figure 7.24 Church in El Mozote, Morazán where men in the community were detained, tortured and executed. The church was rebuilt as a memorial site to the victims of the El Mozote massacre (author photograph 2009).**



**Figure 7.25 The hills behind the church in El Mozote, Morazán where young girls and women were taken to be raped and executed (author photograph 2009).**

Despite the insistent rejection by the Salvadoran government, Rufina's testimony has been confirmed by a thorough forensic anthropological investigation.

Despite ample evidence at the time of the truth commission's investigations, the CVES makes no mention of sexual violence in their analysis of the massacre at El Mozote. While the final report indicates that the men and women of the community were separated before being killed (a fact suggesting that they were to be treated differently), there is no mention of sexual violence or any gendered analysis of the event. It states:

[t]hey separated the men from the women and children...During the morning, they proceeded to interrogate, torture and execute the men in various locations. Around noon, they began taking out the women in groups, separating them from their children and machine-gunning them.  
(CVES 1992, 115)

The CVES' oversight of the gender-specific forms of violence during military operations in the countryside is not unique to the case of El Mozote. In another case, the CVES states that sexual violence did occur, but does not report any of the details of the crimes, nor do they link these violations to the other politically-motivated violence that occurs simultaneously in the community. The CVES writes:

[o]n 12 March 1981, soldiers and members of the Cacaopera unit of the Defensa Civil attack the population [of El Junquillo], consisting solely of women, young children and the elderly. They killed the inhabitants and raped a number of women and little girls under the age of 12.  
(CVES 1992, 67)

Similarly, on March 17, 1980 there was a large joint military operation by the FAES and the GN in Suchitoto, Cuscatlán. The soldiers invaded Hacienda Colima and killed more than 20 campesinos. Many women were raped before being executed. Those who were not killed were taken away on an Army truck (SJC 23.2.9).

Sexual violence was common during military operations in rural communities, even when victims were not subsequently killed. For example, in August 1980, a heavily armed contingent of soldiers arrived in Tecoluca, San Vicente. They invaded the haciendas in the community and went house to house rounding up the residents. When they arrived at Marta's house, they accused her husband, Lucero, of being a member of the FPL and demanded to know where he was. She told them that he had gone to San Salvador to look for work, but they did not believe her. They searched the entire house, repeatedly asking where Lucero kept his weapons. Infuriated, they began to punish her. They severely beat her. They threw her to the floor and gang raped her, calling her a whore. During the same community raid, the soldiers raped many other women, including Marta's young cousin, who later died as a result of injuries she sustained during the attack (SJC, 26.8.2).

It was not always the women who were raped by soldiers during military operations in the countryside. For example, in September 1980, in Barrio El Calvario, Cojutepeque, Cuscatlán, armed men in civilian clothes abducted three men from their homes in the middle of the night. The next day, their mutilated bodies were found on the outskirts of town. Their bodies bore the marks of having been raped with machetes. One of the men had his penis and testicles severed. Military and paramilitary forces would sometimes leave the lifeless and mutilated bodies of their victims on display in public places in order to heighten the terrorizing impact of the killing and sexual assault and to psychologically and politically paralyze those who survive (Hollander 1996).

Graphic cases, such as the one presented above, are not the only forms of sexual violence that occur in rural communities. Indeed, it is not always the case that an act of

*physical* aggression occurs at all. The following attack is typical of state military operations in rural communities. On May 16, 1990, 100 troops of the 2<sup>nd</sup> Infantry Brigade wearing camouflage uniforms stormed a village in Coatepeque, Santa Ana. They went first to the local agricultural cooperative, where they captured five men and then began to raid each house and capture those found inside. The soldiers gathered the men of the community together in the street and told them that they would not detain the women and that they would not “touch their women” if they answered their questions and agreed to cooperate. This case illustrates that the soldiers believed that sexual violence is a powerful tool to coerce, manipulate and otherwise control the population. The simple suggestion or threat of raping the women attacks the men’s masculine identities by questioning their ability to protect their wives and daughters. In this case, the threat of sexual violence was enough to elicit the cooperation, however reluctant, of the men in the community (TL 29.4.10). Incidents of sexual coercion, like the one described above, do not support the opportunistic model of wartime sexual violence. The only potential explanation for why an individual soldier would threaten to, but not actually carry out an act of sexual violence is if the opportunity to do so suddenly disappeared. Perhaps the arrival of a commanding officer prevents the soldier from fulfilling his private desires for violence. However, this explanation is not supported by the evidence. In no case was an attempted act of sexual violence aborted because of a change in the circumstances or environmental conditions. Furthermore, as the data above illustrate, not only does the presence of commanding officers not appear to dissuade soldiers from engaging in criminal behavior, in some cases, their presence encourages such violence.

Because of the limited information on the commission of sexual violence during military operations in rural communities, it is difficult to determine whether these acts were motivated by individual soldiers' desires and opportunities to commit violence or whether they were perpetrated intentionally to terrorize and warn/punish local populations thought to be providing aid to the armed insurgency. There are some cases that appear opportunistic in nature. For example, according to the testimony of another soldier who witnessed the event, while stationed in San Vicente in 1985, two soldiers from the Battalion Cañas gang raped two young civilian woman. The two soldiers were drunk. Rufino and Benito left the military base and went to the victims' home in San Idelfonso. The father of one of the perpetrators confirmed the eyewitness account, saying that his son had confessed to him to committing "private crimes" against two girls while off duty. According to the father, when the commanders of the military base discovered what Rufino and Benito had done, they detained and severely beat them (TL 10.3.12). In this case, it appears that the two soldiers acted alone and without the knowledge or approval of their superior officers. Moreover, that the commanding officers punished the two men responsible indicates that they did not want their soldiers engaging in such criminal behavior. Cases like these are rare.

### **Sexual Violence in State-Run Detention Centers**

The second, and much more frequently reported pattern of sexual violence during the Salvadoran civil war, illustrates that sexual violence was often employed strategically to dehumanize, punish and break and/or interrogate political prisoners. These cases occurred almost exclusively in prisons and military bases under the authority or at the

direction of commanding officers. The following section presents a few illustrative examples.

The detention and torture of Gerardo is typical of this pattern of abuse. On January 28, 1986, while waiting at a bus stop in San Salvador, an unmarked car approached. Six armed men in civilian clothes jumped out of the car and told him that if he ran or tried to signal for help, they would shoot him. They put him in the backseat of the car and blindfolded him. The men took Gerardo to the central station of the PH in San Salvador. While handcuffed and still blindfolded, the men interrogated Gerardo, accusing him of being a guerrilla. When he denied their allegations, the men intensified their attack, twisting his arms behind his back and beating his testicles, causing him to lose consciousness. They officers revived him and repeated their torture. Gerardo was detained at the PH in San Salvador for 15 days. Before transferring him to Mariona prison, the officers forced him to sign a blank piece of paper (TL CV-3700).

Gerardo's case is not unique. Another victim, who refused to give his name, was captured by armed men (some in military uniform, others in plainclothes) while waiting for the bus outside of the *Universidad Nacional de El Salvador* (National University of El Salvador). The men threw the victim into the back of their car and immediately began asking him questions about the guerrillas. They accused him of being a terrorist and beat him in the stomach with their guns. They took him to a police station (the victim did not know where he was) and put him in an interrogation room. The room was covered in human waste. The men stripped him and left him in the room naked. After awhile, a uniformed officer entered, removed his belt and tied it around the victim's testicles. They blasted loud music into the room and began to beat him again – in the stomach, neck and

head. Each time he refused or did not answer satisfactorily their questions, they would beat him again and tighten the belt another notch (SJC 26.7.3).

This kind of sexual violence was often reserved for those individuals deemed to be a threat to the state. The testimony of one victim, Alvarado, is included in its entirety so that the full context in which the sexual violence occurred can be discerned.

In February 1981, I was with my wife and small child at our house in San Salvador when around 11:00pm a group of armed men, some in military uniforms and others in civilian clothes, banged on the door. They said they were from the armed forces and ordered me to open the door. I knew that five other teachers were killed or disappeared in the area and that some others were detained and tortured by security forces. When I opened the door, they immediately threw me on the floor and began kicking me and threatened to kill me if I didn't answer their questions. *Where are you hiding the weapons? Where is the subversive propaganda?* I told them that I didn't have anything like that and they beat me again. They blindfolded me along with my wife and kids and took us to the mayor's office in San Marcos. My wife and kids were later released, but I was sent to CITFA. At 6:00am on the next day, I was sent to the torture room, where they took off my blindfold and I could see there were four people in the room. I could tell by their faces and gestures that they were evil assassins. They began to ask me which organizations I belonged to. They tortured me with electricity on my fingers and feet. Each time they asked me if I was a guerrilla commander; I said no, and they tortured me more. They submerged me in water until I couldn't breathe. I passed out. When I came to, they asked me who my boss was. If I didn't answer, they would put me in the water again. This went on for an hour. Then the four perpetrators grabbed a pole and shoved it in my anus. They wouldn't stop. They burned my penis with electricity. When they took me back to my cell, they said that I should think about my answers. Later, they came back to interrogate me again, this time with machetes. They tied me up and beat me twenty times on my back. When they didn't get the answers they wanted, they showed me a bottle with some sort of liquid in it. They put a little of it on me to show me that it was some sort of acid. They stood around me and told me that if I didn't cooperate with them, they would throw it all over my body. One of them took out a pen and began to mark out the areas on my body that they would apply the acid if I refused to answer their questions. First they would throw it on my back, then my anus, then on my legs and arms, then on my chest and face. And that's exactly what they did. They threw the acid on me in that way. I screamed in agony, but I was tied up, there was nothing I could do. They presented me to an Army Lieutenant who ordered I be taken to the dungeons. While



there, I was kept blindfolded and restrained. They said that I was a member of ANDES 21 de Junio and that ANDES was a front organization for the FPL. I was transferred to the GN, where the treatment was even worse. The GN kicked me, insulted me and electrocuted my hands, feet and temples. One of the forms of torture they used against me was called the *pollo campero*.<sup>187</sup> They stripped me, sponged water all over my body, tied me down to the metal spring mattress of a bed and then ran current through the bed. I was at the GN for six days. When the ICRC came to speak with the prisoners, they hid me. I was later transferred to Mariona. (SJC 25.4.11)

The victim's testimony illustrates how political prisoners would be repeatedly tortured and interrogated. In this case, sexual torture appears to be one additional weapon of the security agents to dehumanize and physically destroy detainees.

Even sexual humiliation, an offense not currently recognized by the ICC as a war crime or a crime against humanity, can be used to dehumanize prisoners and to “prep” them for interrogation. In one such case, armed men in civilian clothes abducted Juan, his father and his brother from their home and took the three men to the local PH station. When they arrived at the police station, the three men were separated. The officers stripped Juan and forced him to wear a pair of women's underwear, mocking him and calling him a faggot. Afterwards, they sent him to the interrogation room. They asked him the same questions over and over again. *What is your name? Where do you live? Who do you work for? Do you know Alesandro, Nerio or Josef?* The officers accused Juan of being a member of the *Fuerzas Armadas de la Liberación* (FAL, Armed Liberation Forces) and threatened to kill him and his mother if he did not confess and give them the names of his leaders. Captain Cheverría oversaw the detention, sexual humiliation, interrogation and subsequent torture (not described above) of the prisoner (TL 10.1.13). Stripping prisoners is a common tactic used by the police to underscore the

---

<sup>187</sup> Pollo Campero is the largest fast food chain in Latin America and mostly serves fried chicken.

detainee's vulnerability and in this case attacked the victim's identity as a heterosexual man, both of which serve to disarm and disorient the prisoner, making him more malleable.

There are a few cases of this pattern that have the markers of opportunistic crimes. Sometimes, soldiers abused their position of power in order to coerce sex from women in the communities where they were stationed or women in their custody. Operating with absolute power and impunity, soldiers could accuse a woman they found desirable or who rebuffed their sexual advances of being a subversive, detain her without question and do with her what they want. For example, in 1986, Gloria was accused of being "suspicious" by a GN officer. He took her into custody and detained her at the GN base in San Salvador. He told her that if she had sex with him, he would let her go. She was later released, but refuses to talk about what happened (TL 12.4.12). In situations like these, women's bodies become commodities to be bought, sold and traded in a market controlled by soldiers (Hollander 1996). As the case of Gloria suggests, women in conflict situations may be forced to trade their bodies for their lives or freedom, or that of a loved one.

To the extent that cases of sexual abuse against prisoners are rare, isolated events, they could be opportunistic crimes perpetrated by individual soldiers. However, as the number of these cases accumulates and follows distinct patterns, this line of reasoning becomes less credible.

## **Conclusion**

This chapter makes several significant contributions to our understanding of wartime sexual violence in El Salvador. It documents the prevalence with which such

crimes were reported to Tutela Legal and Socorro Jurídico Cristiano. While it is important to note that we cannot conclude with certainty that these data reflect the true prevalence with which sexual crimes occurred during the Salvadoran civil war, such data do provide significant insight into the methods and limitations of early human rights organizations to document wartime sexual violence. Important lessons can and should be drawn from the work of these early attempts by those currently working to document sexual violence in Libya, the Sudan, and the Democratic Republic of Congo.

Recognizing the limitations of the data, there are still a number of important findings regarding the patterns of sexual abuse in El Salvador. First, men are more frequently the targets of sexual violence than previously thought and then often recognized in the academic and policy literatures. Second, sexual humiliation, sexual torture and sexual coercion are more frequently perpetrated in times of war than is recognized by the literature that explicitly or implicitly equates wartime sexual violence with rape and gang rape. In addition, sexual violence of all types was much more likely to be perpetrated by state armed forces, especially the GN. Lastly, there were two principal patterns of sexual violence during the civil war in El Salvador. Security agents sometimes (although how frequently cannot be determined due to data limitations) committed sexual violence, in particular rape, while carrying out military operations in rural communities. In addition, security agents often committed sexual violence, particularly sexual torture and humiliation, against suspected or real political opponents in their custody. Of these latter cases, sexual violence was significantly more likely to be perpetrated in state-run detention facilities and under the supervision of commanding officers.

The evidence presented in this chapter supports the dissertation thesis that sexual violence is strategic in nature, particularly cases of rape, sexual humiliation and sexual torture that were explicitly used to dehumanize, break and interrogate political opponents.

## CHAPTER 8: CONCLUSION

This dissertation project was motivated by two key research goals. The first was simply to contribute to the empirical knowledge on wartime sexual violence by documenting its occurrence during the civil wars in Peru and El Salvador. The second was to investigate why state militaries commit such abuses. This chapter will briefly summarize the work completed in the dissertation and the key empirical, methodological and theoretical contributions of the study to our understanding of wartime sexual violence.

The data used in this study were collected during two years of field research in El Salvador, Peru and the United States. Using the archived records of human rights institutions, I read approximately 7,000 individual, first-person testimonies of violence. Primary documents of this sort provide a unique opportunity for researchers to investigate sexual violence and other war crimes. Because of the logistical and ethical challenges of interviewing victims and perpetrators of sexual violence, scholars should exploit to the fullest extent possible existing repositories of human rights records and other primary documents before (re)interviewing and potentially (re)traumatizing those affected by wartime violence.

Using these testimonial documents, I recorded information on eleven types of human rights violations, including sexual violence. Employing a broader definition of sexual violence than previous studies, I collected data on six forms of sexual abuse, including rape, gang rape, sexual torture and mutilation, sexual humiliation and other, unspecified forms of sexual violence. I also included in the database cases where armed

combatants attempted or threatened to carry out one of these forms of violence, but were either unable or chose not to.

Some scholars may disagree with this broad conceptualization, arguing that it overextends the parameters of the term. I argue, however, that important insight is gained by exploring the multiple forms of sexual abuse and if/how they are employed differently in conflict situations. If our objective is to understand why armed groups attack civilians and combatants in ways that are inextricably linked to their gender and sexual identities, focusing exclusively on rape risks overlooking some of the most common forms of sexual abuse and misunderstanding the causes of such violence. Most importantly, the dissertation urges researchers and human rights investigators to consider carefully their conceptualization and operationalization of sexual violence. The concept and coding procedures adopted in this study are clearly specified (see Chapter 3 and Appendix D) such that future analyses can be easily carried out, changing or restricting the dependent variable.

Using data of this kind, however, is not without its obstacles. Researchers relying on the testimonies collected by truth commissions or other non-governmental human rights groups for data on sexual or other forms of political violence must have an intimate familiarity with the organization and workings of the reporting agency. Any findings derived from the data must be considered against the biases of the reporting mechanisms. To understand the potential limitations of the data, I conducted approximately 45 interviews with members of the truth commission in Peru and Tutela Legal and SJC in El Salvador. Additional interviews with other non-governmental human rights

organizations were conducted in order to better understand how such organizations operate in times of war and conduct investigations of human rights abuses.

These data make several key contributions to our empirical knowledge on wartime sexual violence. While less frequent than in other conflicts, these data demonstrate that sexual violence is not limited to ethnic conflicts or civil wars in Africa. In particular, they contribute to our empirical knowledge of wartime sexual violence in Latin America, a region often neglected in this area of study. The data reveal that sexual violence was more frequent during the civil war in El Salvador than previously thought, but was still less prevalent than during the civil war in Peru.

The data confirm the findings of other scholars (Cohen 2010) that sexual violence is more often perpetrated by state armed forces than it is by non-state armed groups. This is true even in Peru where it was the rebels, not the state, that committed the majority of all acts of lethal violence. As Wood (2010) has discussed, this asymmetry in the perpetration of sexual violence is notable because it proves that sexual violence is not the inevitable consequence or by-product of war.

However, the data challenge other assumptions in the literature. Specifically, the data invalidate the implicit assumption of many that sexual violence is a uniquely feminine experience. Broadening the conceptualization of sexual violence, reveals that in both Peru and El Salvador, men were much more frequently the object of sexual violence, particularly sexual humiliation and torture, than previously thought. This finding invalidates theories of wartime sexual violence that essentialize gender roles in times of war and assume that sexual violence is (almost) always perpetrated by men against women. It further highlights the need for international humanitarian agencies to provide

medical and psychological services to both female and male survivors of sexual violence.<sup>188</sup>

Using this data, I conducted chi-square difference tests to examine the ways in which sexual violence differs from other wartime human rights violations. These tests revealed three important findings. First, victims of sexual violence are statistically different from those not targeted for sexual forms of violence. Victims of sexual violence are more likely to be educated women living in more urban settings and who are political or socially active in their communities. Understanding the ways in which victims of sexual violence are likely to be different from the broader population of victims of violence during civil war can help international aid organizations to identify populations at risk and decide how to allocate their limited resources.

Second, sexual violence is more likely to be perpetrated in private spaces and particularly more frequently perpetrated in state-run detention centers when commanding officers are present than other forms of political violence. Lastly, sexual violence is much less likely to be perpetrated by non-state rebel groups than it is to be perpetrated by state militaries. Within the state armed forces, the army and police are significantly more likely to engage in these forms of violence than other sectors of the security apparatus. Notably, paramilitary groups and death squads are much less likely to engage in sexual violence than they are to perpetrate other forms of violence, particularly lethal violence. These findings were subjected to robustness checks and remain even when sexual

---

<sup>188</sup> One area of particular concern and about which we know very little, is whether men who are victims of sexual violence in times of war are more likely to later sexually or otherwise abuse their partners or children. Hollander (1996) has suggested that “men who are unable to direct their rage at the that is responsible for their victimization are apt to displace these emotions onto safer and traditionally socially acceptable objects. Wife battering and rape is a likely arena where male aggression would be expressed...” (64). If this is the case, then providing mental health services to male victims of sexual violence is of paramount importance.



violence is limited to those violations currently recognized by the International Criminal Court as war crimes.

Theoretically, the dissertation addresses the central debate in the literature on wartime sexual violence. While there is evidence that opportunistic soldiers will sometimes commit acts of sexual aggression, the preponderance of evidence demonstrates that sexual violence is often an instrumental weapon of war wielded to defeat armed and unarmed opponents to the state.

Broadening our theorization of the causes of wartime sexual violence beyond the context of ethnic conflicts, I present a model of sexual violence in irregular, counterinsurgency wars. To test the theory, I examined the timing and location of such attacks in the context of the developments of the civil war in Peru. Using negative binomial regression, I found a curvilinear relationship between the frequency of wartime sexual violence and the threat level presented by the Shining Path. In other words, at times and in locations where the rebels were not active or did not pose a significant threat to the stability of the state, the state engaged in only minimal levels of sexual violence. Sexual violence was similarly minimal at times and in places where the rebels were their strongest. Sexual violence was most frequent in those areas where the rebels were gaining in strength and beginning to present a significant threat to the state but where the state estimated that their takeover could still be prevented. This theory is likely generalizable to other civil and international wars in which the nature of the opposition requires the military to employ counterinsurgency tactics to identify, locate and defeat the armed opposition.

When examined in detail, the context in which sexual violence is carried out reveals two key patterns of abuse. First, state armed agents often commit sexual violence when deployed to rural communities. In Peru, this often occurred during periods of states of emergency when the military assumed political control over a territory. Second, military and police forces often use sexual violence as a method to intimidate, punish and interrogate those detained for political crimes. Taken together, these findings demonstrate that wartime sexual violence is not random but rather the patterned and purposeful behavior of state armed actors. These findings, in turn, increase the legitimacy of international and domestic courts to prosecute the perpetrators *and* intellectual authors of sexual violence as war criminals and underscore that wartime sexual violence can be prevented.

### **Measures to Prevent Wartime Sexual Violence by State Militaries**

All parties to armed conflict [must] take special measures to protect women and girls [, men and boys] from gender-based violence, violence, particularly rape and other forms of sexual abuse, and all other forms of violence in situations of armed conflicts.

(UNSC 2000).

United Nations' Security Council Resolution 1325 mandates that states take effective measures to prevent sexual violence in conflict situations. However, as of yet, there has been little dialogue regarding what those measures might look like, what policies and programs have been used in the past, which failed and which have succeeded. In concluding the dissertation, I would like to encourage states and international human rights organizations to think critically about the details and design of prevention programs by offering a few suggestions derived from the findings of the study. A note of caution is necessary. Policies and programs to prevent sexual violence

in conflict situations cannot and should not be implemented universally without careful consideration of the potential negative consequences of the intervention strategy for intended communities.

While the majority of sexual abuses in Peru and El Salvador do not appear to have been motivated by opportunity alone, reducing the risk or limiting the opportunity for soldiers to engage in such violence is a worthwhile task. Increasing the patrols of state security officers or international peacekeepers in areas where civilians are at greater risk could reduce the frequency of sexual abuse. Periods of states of emergency and displacement or refugee camps are environments of particular concern. In addition, the data on Peru and El Salvador reveal that soldiers are more inclined to engage in opportunistic violence, sexual or otherwise, after consuming drugs and/or alcohol. Regulating the availability of drugs and alcohol on military bases and punishing those who abuse such substances can reduce opportunistic sexual violence in areas surrounding military bases.

The findings of the dissertation suggest that the international community should focus their efforts on changing the norms and interests of state militaries to engage in this form of violence more than on reducing or eliminating the opportunities for individual soldiers to commit abuses. While policymakers have long advocated gender mainstreaming within political and military institutions, incorporating women within these patriarchal structures is not sufficient and will not automatically result in cultural or normative change. Sustained human rights education is necessary to create fighting units that respect the laws of war (Hoover 2011). Similarly, the procedures, education and communication of the military must be reconsidered in a gender sensitive framework that

is locally informed before soldiers and their leaders stop viewing sexual violence as a legitimate and effective weapon of war.

## APPENDICES

|            |                                                                                            |     |
|------------|--------------------------------------------------------------------------------------------|-----|
| Appendix A | Guide to Collections of Archive Human Rights Documents in Peru and El Salvador             | 272 |
| Appendix B | Intake Forms from Socorro Jurídico Cristiano and Tutela Legal del Arzobispado, El Salvador | 276 |
| Appendix C | Intake Forms from the Comisión para la Verdad y Reconciliación, Peru                       | 279 |
| Appendix D | Codebook on Human Rights Violations and Violent Events in Peru and El Salvador             | 289 |
| Appendix E | Model Variations                                                                           | 298 |
| Appendix F | Agenda for Future Research in El Salvador                                                  | 299 |

## APPENDIX A

### GUIDE TO COLLECTIONS OF ARCHIVED HUMAN RIGHTS DOCUMENTS IN PERU AND EL SALVADOR\*

The Centro de Información para la Memoria Colectiva y los Derechos Humanos (CIMCDH; The Center for Information on Collective Memory and Human Rights) in Lima holds the complete records of the Comisión para la Verdad y Reconciliación (CVR, Commission for Truth and Reconciliation), files from former district attorneys and special prosecutors, and files from the Defensoría del Pueblo (Office of the Ombudsman) and the human rights branch of the Ministerio Público (Public Prosecutor) of the Peruvian state. Among its primary sources are internal reports, memoranda, and photographs documenting the institutional history of the CVR and news articles and photojournalistic accounts of the conflict as it unfolded. In addition, the CIMCDH has a collection of approximately 3,500 secondary sources on topics related to human rights, political violence, and transitional justice in Peru, as well as other countries (predominantly in Latin America). Included in this library are all the secondary materials the CVR used in conducting its analyses and writing the final report.

The gem of the archive, however, is the 16,917 testimonies collected by teams of investigators throughout the country, which document the most violent period in Peruvian history as seen through the eyes of its citizens. The testimony files are of tremendous value to scholars. Each file contains the original intake forms used by field workers to record demographic information on the interview, the deponent, and the victims and perpetrators of violence. These forms are accompanied by a transcription of the

---

\* Special thanks to the dedicated staff of the University of Colorado at Boulder Archives Department and the Centro de Información para la Memoria Colectiva y los Derechos Humanos in Peru for the important work that they do in preserving the historical record so that we may never forget the extraordinary costs of civil war.

deponent's statement describing the event. In addition, files may hold various supplemental documents such as pictures to identify victims who have disappeared or copies of previous denunciations filed by the victim's family.

In addition to victim and witness denunciations of violence, the Center also holds statements made to the Commission by alleged or confessed perpetrators. For the most part, these exist only in audio or video formats, and have not been transcribed. These interviews provide incredible insight into individuals' command posts throughout the war, military policy and operations, military training practices, and degrees of cooperation between branches of the state security apparatus, as well as officials' understanding of the nature of the opposition threat and prospects for a negotiated settlement to the conflict.

Staff at the Center can search the database of testimonies according to the name of the victim, the deponent (or person who gave the testimony), or the date or location of the violent event. This is an invaluable tool for researchers. For instance, someone interested in a particular region or community, such as Accomarca in Ayacucho, can ask the staff to search the database and pull all testimonies that discuss violence in Accomarca and/or all testimonies that were taken in Accomarca. More specifically, someone wanting to investigate the massacre in Accomarca on August 14, 1985, can ask the staff to search the database according to the location and date of the massacre. Unfortunately, the database is not searchable according to the type of violation coded by the Commission. However, because all of the testimonies have been digitalized, staff can conduct keyword searches to circumvent this setback. The latter scenario is in fact preferable for researchers who may be concerned about the criteria used to code human rights abuses, as I have

discussed may be the case with sexual violence.

In 1997, Socorro Jurídico Cristiano and Tutela Legal gifted copies of the testimonies they collected to the University of Colorado, Boulder, which has since served as a secondary depository and safe house for the organizations' records. The collection includes 64 boxes of case files on victims and survivors of political violence. Each file contains a standardized in-take form used by staff to record demographic information on the individual making the statement and the victim, and contextual information on the incident being reported, the alleged perpetrators involved and any measures taken by those involved to file a criminal charge or denunciation regarding the case. Some files include additional information on the case, such as news reports, letters and petitions to the Supreme Court from the families of the victims, letters to state security agencies and the FMLN from Tutela Legal or SJC (acting on behalf of the victims and their loved ones) requesting information on the case, demanding the release of those captured, and/or demanding the prosecution of those involved in human rights violations, as well as responses to those letters from state security and judicial institutions.

The University also has the archived testimonies collected by the non-governmental Comisión de los Derechos Humanos de El Salvador. The collection includes the individual testimonies of witnesses and victims of violence during the civil war, as well as supplemental secondary materials gathered by the CDHES during their investigations between 1974 and 1992. Each case file contains biographical information about the victim, the date and place of the attack, the alleged perpetrator(s), and a narrative description of the circumstances surrounding the attack. There are 36 boxes of case files in the collection. In addition to the testimonial records of Tutela Legal, SJC



and the CDHES, the University also holds archived materials from the National Security Archives in Washington, DC, and Amnesty International relevant to the war in El Salvador and the peace process.

Due to budgetary cutbacks, the collections remain in the original state as when they first arrived at the University. The contents of the collections have not been evaluated or systematically catalogued. The materials are not digitized. Particularly in the case of the National Security Archives materials and the SJC testimonies, there are a significant number of duplicated documents in the collections, which remain largely unorganized. Despite this, the wealth of information available and the knowledgeable staff make the Archives Department at the University of Colorado, Boulder an invaluable research site for scholars of the Salvadoran civil war.

APPENDIX B

INTAKE FORMS FROM SOCORRO JURÍDICO CRISTIANO AND TUTELA  
LEGAL DEL ARZOBISPADO, EL SALVADOR

SOCORRO JURIDICO CRISTIANO  
DE EL SALVADOR

FECHA \_\_\_\_\_  
ATENDIDO POR \_\_\_\_\_

CAPTURADO POR MOTIVO POLITICO

1º.-NOMBRE \_\_\_\_\_ EDAD \_\_\_\_\_  
PROFESION U OFICIO \_\_\_\_\_ EST.CIVIL \_\_\_\_\_  
ORIGEN O DOMICILIO \_\_\_\_\_  
CENTRO DE TRABAJO O ESTUDIO \_\_\_\_\_  
NOMBRE DEL PADRE \_\_\_\_\_  
NOMBRE DE LA MADRE \_\_\_\_\_  
ESPOSA (O), COMPAÑERA DE VIDA \_\_\_\_\_  
NUMERO DE HERMANOS O HIJOS QUE DEJA \_\_\_\_\_ EDAD DEL MA-  
YOR \_\_\_\_\_ EDAD DEL MENOR \_\_\_\_\_

2º.-FECHA DE CAPTURA \_\_\_\_\_ HORA \_\_\_\_\_ LUGAR \_\_\_\_\_  
NOMBRES DE LOS TESTIGOS \_\_\_\_\_  
CAPTOR \_\_\_\_\_  
CIRCUNSTANCIAS DE LA DETENCION \_\_\_\_\_  
\_\_\_\_\_  
\_\_\_\_\_  
\_\_\_\_\_  
\_\_\_\_\_  
\_\_\_\_\_  
\_\_\_\_\_

3º.-DIO LOS DATOS \_\_\_\_\_ PARENTESCO CON \_\_\_\_\_  
EL CAPTURADO \_\_\_\_\_ DIRECCION Y NUMERO DE TELEFONO \_\_\_\_\_  
\_\_\_\_\_

4º.-PRESENTARA LA PETICION DE EXHIBICION PERSONAL \_\_\_\_\_  
ESTADO CIVIL \_\_\_\_\_ EDAD \_\_\_\_\_ PROFESION U OFICIO \_\_\_\_\_  
PARENTESCO CON EL DETENIDO \_\_\_\_\_  
DOMICILIO O RESIDENCIA \_\_\_\_\_  
Nº. DE CEDULA \_\_\_\_\_ LUGAR Y FECHA DE EXTENSION \_\_\_\_\_  
A QUE OTRAS INSTITUCIONES HA ACUDIDO ? \_\_\_\_\_  
\_\_\_\_\_

  
FIRMA O HUUELLA DEL DENUNCIANTE

IMPORTANTE!!!! EXIGIR CERTIFICACION PARTIDA NAC., FOTO, ETC. DE LA VICTIMA.-



OFICINA DE TUTELA LEGAL DEL ARZOBISPADO  
 COMISION ARQUIDIOCESANA DE JUSTICIA Y PAZ  
 Apdo. 2253 — San Salvador, El Salvador, C. A.

RECORD N° \_\_\_\_\_

FECHA: \_\_\_\_\_

ATENDIDO POR: \_\_\_\_\_

**DENUNCIA POR MOTIVOS POLITICOS**

**I — DATOS DE LA VICTIMA**

APELLIDOS \_\_\_\_\_

NOMBRES \_\_\_\_\_

LUGAR DE NACIMIENTO \_\_\_\_\_

FECHA DE NACIMIENTO \_\_\_\_\_ EDAD \_\_\_\_\_

DIRECCION DE LA VICTIMA EN LA FECHA DE SU CAPTURA O DESAPARICION \_\_\_\_\_



FOTO

DEPARTAMENTO \_\_\_\_\_

ESTADO CIVIL \_\_\_\_\_ SEXO \_\_\_\_\_ SECTOR\* \_\_\_\_\_

OCUPACION \_\_\_\_\_

ACTIVIDAD POLITICA \_\_\_\_\_

ACTIVIDAD SINDICAL \_\_\_\_\_

ACTIVIDAD RELIGIOSA \_\_\_\_\_

ESTADO ACTUAL DE LA VICTIMA\* \_\_\_\_\_

TIPO DEL HECHO\* \_\_\_\_\_

RESPONSABLE\* (CAPTOR) \_\_\_\_\_

FECHA DEL HECHO \_\_\_\_\_ HORA DEL HECHO \_\_\_\_\_

DIRECCION DEL HECHO \_\_\_\_\_

LUGAR DEL HECHO \_\_\_\_\_

LUGAR DE APARICION DE LA VICTIMA (Cuerpo de Seguridad u otros) \_\_\_\_\_

DESCRIPCION DETALLADA DEL HECHO DENUNCIADO (CIRCUNSTANCIAS):

NACIONALIDAD DE LA VICTIMA \_\_\_\_\_  
CENTRO DE TRABAJO DE LA VICTIMA - \_\_\_\_\_  
CENTRO DE ESTUDIO DE LA VICTIMA - \_\_\_\_\_  
DIRECCION ACTUAL DE LA VICTIMA - \_\_\_\_\_  
NOMBRE DEL PADRE \_\_\_\_\_  
NOMBRE DE LA MADRE \_\_\_\_\_  
NOMBRE ESPOSO(A) O COMPAÑERO(A) DE VIDA \_\_\_\_\_  
NUMERO DE HERMANOS ( ) O HIJOS ( ) QUE DEJA \_\_\_\_\_  
EDAD DEL MAYOR \_\_\_\_\_ EDAD DEL MENOR \_\_\_\_\_  
CAUSA DE LA DENUNCIA \_\_\_\_\_  
TESTIGOS DEL HECHO (Nombre y Dirección) \_\_\_\_\_

VESTIMENTA DE LA VICTIMA \_\_\_\_\_

DESCRIPCION DE LA VICTIMA \_\_\_\_\_

FUE CAPTURADO(A) ANTERIORMENTE \_\_\_\_\_

FAMILIARES, PARIENTES, AMIGOS, CONOCIDOS O VECINOS DE LA VICTIMA CAPTURADOS, SE  
CUESTRADOS O DESAPARECIDOS: (NOMBRES Y FECHAS) \_\_\_\_\_

II — DATOS DE LA PERSONA QUE PRESENTA LA DENUNCIA

APELLIDOS \_\_\_\_\_

NOMBRES \_\_\_\_\_

LUGAR Y FECHA DE NACIMIENTO \_\_\_\_\_

NACIONALIDAD \_\_\_\_\_ ESTADO CIVIL \_\_\_\_\_

EDAD \_\_\_\_\_ PROFESION, OCUPACION U OFICIO \_\_\_\_\_

Nº DE CEDULA \_\_\_\_\_ LUGAR Y FECHA DE EXPEDICION \_\_\_\_\_

\_\_\_\_\_ DOMICILIO \_\_\_\_\_

CENTRO DE TRABAJO O ESTUDIO \_\_\_\_\_

DIRECCION ACTUAL (Si no está dentro del radio urbano, describirla para su localización) \_\_\_\_\_

DIRECCION POSTAL \_\_\_\_\_ TELEFONO \_\_\_\_\_

PRESENTA LA DENUNCIA EN CALIDAD DE \_\_\_\_\_

PARENTESCO O TIPO DE RELACION CON LA VICTIMA \_\_\_\_\_

SI LA PERSONA NO ES LA VICTIMA, NI SU REPRESENTANTE LEGAL, DEBERA EXPONER CLARAMENTE:

— LAS RAZONES QUE TIENE PARA CREER QUE LA VICTIMA ES INCAPAZ DE PRESENTAR UNA DENUNCIA EN NOMBRE PROPIO \_\_\_\_\_

## APPENDIX C

### INTAKE FORMS FROM THE COMISIÓN PARA LA VERDAD Y RECONCILIACIÓN, PERU

Testimonio N°

**FICHA N° 1: DATOS DEL TESTIMONIO**

1. Sede       2. Fecha:  /  /       3. Hora inicio  :       4. Hora fin  :

5. Lugar de la entrevista:

|                |           |          |
|----------------|-----------|----------|
| Departamento   | Provincia | Distrito |
| Centro Poblado |           |          |

6. Apellidos y Nombres de los entrevistadores

|                  |                  |         |
|------------------|------------------|---------|
|                  |                  |         |
|                  |                  |         |
| Apellido Paterno | Apellido Materno | Nombres |

7. ¿Se autorizó que el testimonio sea grabado?       Sí       No      8. Número de cassettes grabados:

9. ¿En qué idiomas se realizó la entrevista?

Castellano       Quechua       Aymara       Shipibo       Ashaninka       Mashigaanga  
 Otro (especificar):

10. Durante la entrevista ¿se contó con un traductor?       Sí       No

11. Apellidos y Nombres del traductor:

|                  |                  |         |
|------------------|------------------|---------|
|                  |                  |         |
|                  |                  |         |
| Apellido Paterno | Apellido Materno | Nombres |

12. Información sobre las violaciones:

|                                                                                                                                                                                                                                                                                                                                                                                                                                                                                                                                                                                                                                     |                             |                                                                                              |
|-------------------------------------------------------------------------------------------------------------------------------------------------------------------------------------------------------------------------------------------------------------------------------------------------------------------------------------------------------------------------------------------------------------------------------------------------------------------------------------------------------------------------------------------------------------------------------------------------------------------------------------|-----------------------------|----------------------------------------------------------------------------------------------|
| Temas de la entrevista:                                                                                                                                                                                                                                                                                                                                                                                                                                                                                                                                                                                                             | Cantidad Total de víctimas: | Cantidad Aproximada                                                                          |
| <input type="checkbox"/> Muerte<br><input type="checkbox"/> Desaparición<br><input type="checkbox"/> Tortura o malos tratos<br><input type="checkbox"/> Detención o secuestro<br><input type="checkbox"/> Violencia sexual<br><input type="checkbox"/> Procesos judiciales / Problemas judiciales<br><input type="checkbox"/> Despojo o destrucción de bienes y propiedades<br><input type="checkbox"/> Utilización forzada de personas<br><input type="checkbox"/> Fosas<br><input type="checkbox"/> Otros temas (especifique): <span style="border: 1px dashed black; display: inline-block; width: 100px; height: 15px;"></span> |                             | <input type="checkbox"/> Cantidad Aproximada<br><input type="checkbox"/> Cantidad Aproximada |

13. Relación de lugares y fechas en los que se cometieron las violaciones

|              |           |                                                                                                                                                                                                                                                                                                                                                                                        |
|--------------|-----------|----------------------------------------------------------------------------------------------------------------------------------------------------------------------------------------------------------------------------------------------------------------------------------------------------------------------------------------------------------------------------------------|
|              |           |                                                                                                                                                                                                                                                                                                                                                                                        |
|              |           |                                                                                                                                                                                                                                                                                                                                                                                        |
|              |           |                                                                                                                                                                                                                                                                                                                                                                                        |
|              |           |                                                                                                                                                                                                                                                                                                                                                                                        |
| Departamento | Provincia | Distrito                                                                                                                                                                                                                                                                                                                                                                               |
|              |           | <span style="border: 1px solid black; display: inline-block; width: 20px; height: 15px;"></span> / <span style="border: 1px solid black; display: inline-block; width: 20px; height: 15px;"></span> / <span style="border: 1px solid black; display: inline-block; width: 20px; height: 15px;"></span><br><small style="display: block; text-align: center;">Dia    Mes    Año</small> |

14. Cantidad de Fichas Utilizadas:

Ficha 2: Datos del declarante      
 Ficha 3: Datos de la víctima      
 Ficha 4: Datos del Presunto Responsable Individual   
 Fichas premortem (EPAF)

15. Nivel de detalle sobre los hechos:       Muy detallado       Medianamente detallado       Poco detallado





**PARTE B**

11. ¿Otras personas además de usted saben algo sobre los hechos que nos ha contado? ¿Quiénes, sobre qué hechos y cómo podemos ubicar a esas personas?

| Apellido Paterno/Apellido Materno/Nombres | ¿Qué información podría proporcionar? | Ubicación y/o dirección |
|-------------------------------------------|---------------------------------------|-------------------------|
|                                           |                                       |                         |
|                                           |                                       |                         |
|                                           |                                       |                         |
|                                           |                                       |                         |
|                                           |                                       |                         |
|                                           |                                       |                         |

**12. El declarante:**

Es una de las víctimas?  Sí  No

Es testigo directo de alguno de los hechos narrados?  Sí  No

Es responsable de alguno de los hechos narrados?  Sí  No

**AUTORIZACIÓN**

¿Autoriza usted a la Comisión de la Verdad y Reconciliación a que su nombre figure en el informe final de la Comisión?

Sí  No

Declarante

Firma

Huella

Otro:

Firma

Huella

**COMPROMISO**

Los abajo firmantes, en representación de la Comisión de la Verdad y Reconciliación, nos comprometemos a respetar la voluntad del declarante tal como se establece en la autorización dada.

Entrevistador 1

Firma

Huella

Entrevistador 2

Firma

Huella

Lugar

Fecha





**12. Apellidos y Nombres de los padres de la víctima:**

PADRE:

|                  |                  |
|------------------|------------------|
|                  |                  |
| Apellido Paterno | Apellido Materno |

Nombres

MADRE:

|                  |                  |
|------------------|------------------|
|                  |                  |
| Apellido Paterno | Apellido Materno |

Nombres

**13. ¿Cuál es el último nivel educativo alcanzado por la víctima?**

|                                     |                                     |                                    |                                          |                                         |
|-------------------------------------|-------------------------------------|------------------------------------|------------------------------------------|-----------------------------------------|
| <input type="checkbox"/> Sin Instr. | <input type="checkbox"/> Prim. Inc. | <input type="checkbox"/> Sec. Inc. | <input type="checkbox"/> Sup. Tec. Inc.  | <input type="checkbox"/> Sup. Un. Inc.  |
| <input type="checkbox"/> Inicial    | <input type="checkbox"/> Prim. Com. | <input type="checkbox"/> Sec. Com. | <input type="checkbox"/> Sup. Tec. Comp. | <input type="checkbox"/> Sup. Un. Comp. |

▶ 14. ¿La víctima sabía leer y escribir?  Sí  No

**15. ¿Cuál es la última profesión u oficio de la víctima?**

|                                                                                                                                                                                                                                                                                                                                                                                                                                              |  |  |  |  |  |  |  |  |  |  |  |  |  |  |  |  |
|----------------------------------------------------------------------------------------------------------------------------------------------------------------------------------------------------------------------------------------------------------------------------------------------------------------------------------------------------------------------------------------------------------------------------------------------|--|--|--|--|--|--|--|--|--|--|--|--|--|--|--|--|
|                                                                                                                                                                                                                                                                                                                                                                                                                                              |  |  |  |  |  |  |  |  |  |  |  |  |  |  |  |  |
| <table border="1" style="width: 100%; text-align: center;"> <tr> <td style="width: 12.5%;"> </td><td style="width: 12.5%;"> </td><td style="width: 12.5%;"> </td><td style="width: 12.5%;"> </td><td style="width: 12.5%;"> </td><td style="width: 12.5%;"> </td><td style="width: 12.5%;"> </td><td style="width: 12.5%;"> </td> </tr> <tr> <td> </td><td> </td><td> </td><td> </td><td> </td><td> </td><td> </td><td> </td> </tr> </table> |  |  |  |  |  |  |  |  |  |  |  |  |  |  |  |  |
|                                                                                                                                                                                                                                                                                                                                                                                                                                              |  |  |  |  |  |  |  |  |  |  |  |  |  |  |  |  |
|                                                                                                                                                                                                                                                                                                                                                                                                                                              |  |  |  |  |  |  |  |  |  |  |  |  |  |  |  |  |

**16. Durante el periodo en que ocurrieron los hechos, ¿cuál era la ocupación de la víctima y en dónde la desarrollaba?**

| Año o periodo | Actividades | Centro de trabajo |
|---------------|-------------|-------------------|
|               |             |                   |
|               |             |                   |
|               |             |                   |

|  |  |  |  |  |  |  |  |
|--|--|--|--|--|--|--|--|
|  |  |  |  |  |  |  |  |
|  |  |  |  |  |  |  |  |

**17. ¿La víctima estudiaba en el periodo en que ocurrieron los hechos?**

Sí  No

| Año o periodo | Centro de estudios | Nivel o grado de estudios | Especialidad |
|---------------|--------------------|---------------------------|--------------|
|               |                    |                           |              |
|               |                    |                           |              |
|               |                    |                           |              |

|  |  |  |  |  |  |  |  |
|--|--|--|--|--|--|--|--|
|  |  |  |  |  |  |  |  |
|  |  |  |  |  |  |  |  |

**18. ¿La víctima participaba en alguna organización cuando ocurrieron los hechos? (religiosa, política, gremial, estudiantil, social, cultural, etc.)**

Sí  No

| Año o periodo | Nombre de la organización y breve descripción | Cargo que desempeñaba |
|---------------|-----------------------------------------------|-----------------------|
|               |                                               |                       |
|               |                                               |                       |
|               |                                               |                       |

|  |  |  |  |  |  |  |  |
|--|--|--|--|--|--|--|--|
|  |  |  |  |  |  |  |  |
|  |  |  |  |  |  |  |  |









## APPENDIX D

### CODEBOOK ON HUMAN RIGHTS VIOLATIONS AND VIOLENT EVENTS IN PERU AND EL SALVADOR

**OBS\_ID** numeric variable, 7 digit code.

**EVENT\_ID** numeric variable, 7 digit code. An event includes one or more violations of human rights of one or more victims, perpetrated by one or more perpetrators.

**TESTIMONY\_ID** numeric variable, 6 digit code to reference the original document at the archives.

**NUM\_TESTIMONIES** discrete numeric variable, the number of testimonies in which the victim's case is mentioned.

**VIOL** categorical variable, type of violation

1= forced disappearances, whereabouts of individual still unknown. Forced disappearance is defined as “the arrest, detention or abduction of persons by, or with the authorization, support or acquiescence of, a State or a political organization, followed by a refusal to acknowledge that deprivation of freedom or to give information on the fate or whereabouts of those persons, with the intention of removing them from the protection of the law for a prolonged period of time” (ICC 1998).

2= arbitrary arrest and/or deprivation of one's liberty and freedom of movement. Detention is distinguishable from other crimes in which an individual is deprived of his/her liberty in that it is a more formal process and occurs within state-run detention facilities, such as prisons or military bases. By definition, then, *only* members of the state security forces could commit an act of detention.

3= forced recruitment, defined as the forced participation in active combat or other operations of a state or non-state armed group.

4= kidnapping, defined as the arbitrary deprivation of one's liberty and freedom of movement, but which does not occur within formal detention facilities. Perpetrated by either state or non-state armed groups, kidnappings and other informal detentions include any act where a person is taken and held against his/her will for a period of time in a location that is not legally sanctioned as a holding facility.

5= extrajudicial execution. Extrajudicial execution is defined as any homicide, whether individual or collective, committed in the context of the civil war that is perpetrated by members of the state armed forces, a non-state armed group, or other armed actor outside of the judicial process and without due process.

6= battle-related death between two or more armed organizations, whether state or non-state

7= massacre, extrajudicial execution of five or more persons. A similar threshold was adopted by Ball, et al. 2000.

8= battle massacre, the death of five or more persons during a battle between two or more armed organizations, whether state or non-state

9= injury or wound

10= torture, excluding forms of sexual torture. Torture is defined by the International Criminal Court as “the intentional infliction of severe pain or suffering, whether physical or mental, upon a person in the custody or under the control of the accused; except that torture shall not include pain or suffering arising from, inherent in or incidental to, lawful sanctions” (1998).

11= sexual violence, including rape and gang rape, sexual humiliation, sexual torture, sexual mutilation, attempted and threatened acts of sexual violence, and unspecified forms of sexual violence

**ICC\_TV** dichotomous variable, in cases of sexual violence, is the violation recognized by the International Criminal Court as a war crime, crime against humanity or act of genocide (1= yes, 0= no).

**RAPE** dichotomous variable, in cases of sexual violence, is the violation rape (1= yes, 0= no). As defined by the International Criminal Court, rape is the “invasion of the body of a person by conduct resulting in penetration, however slight, of any part of the body of the victim or of the perpetrator with a sexual organ, or of the anal or genital opening of the victim with any object or any other part of the body” (ICC 2000).

**GANG\_RAPE** dichotomous variable, in cases of sexual violence, is the violation gang rape (1= yes, 0= no). Gang rape is defined as rape committed by more than one perpetrator. A violation was coded as gang rape only if it was clear from the testimony narrative that more than one perpetrator actively participated in the rape of the victim. Cases that mentioned multiple victims of rape by multiple perpetrators, but gave no details on the number of perpetrators involved in each individual attack, were recorded as rape, not gang rape (Los soldados abusaron las mujeres de la comunidad/The soldiers raped the women in the community). Similarly, cases in which an individual victim was repeatedly raped by various perpetrators, but where the number of perpetrators involved in each individual attack is not specified, were coded as rape, not gang rape (La mujer fue violada muchas veces por las oficiales/The woman was raped many times by the officers).

**SEX\_TTR** dichotomous variable, in cases of sexual violence, is the violation sexual torture (1= yes, 0= no). Sexual torture is defined as any form of sexual violence that causes severe pain and suffering to the victim, whether physical or psychological.

**SEX\_MUTIL** dichotomous variable, in cases of sexual violence, is the violation sexual mutilation (1= yes, 0= no). Sexual mutilation is defined as any form of sexual violence that results in the removal or permanent damage or scarring of reproductive and sexual organs.

**SEX\_HUMIL** dichotomous variable, in cases of sexual violence, is the violation sexual humiliation (1=yes, 0= no). Sexual humiliation is defined as any offense of a sexual



nature whose primary goal is to humiliate and degrade the victim, but which does not use direct physical force and which does not result in physical injury.

**COERCE** dichotomous variable, in cases of sexual violence, is the violation an attempted or threatened act of sexual violence (1= yes, 0= no).

**UNSPEC\_SV** dichotomous variable, in cases of sexual violence, was the specific type of violation unspecified (1= yes, 0= no). This includes violations such as “sexual abuse,” “sexual violence,” or “sexual attack.”

**VIOL\_VIC** discrete numeric variable, the total number of violations suffered by each victim

**IRR\_VIOL** dichotomous variable, did coders independently agree on the violation code assigned to the case (1= yes, 0= no).

**VIC\_ID** numeric variable, 10 digit code. Anonymous or unnamed victims are assigned an identification code beginning with 2000000001.

**MIN\_VICS** discrete numeric variable, the minimum number of victims involved in the event. Because events often include an unspecified number of unnamed or anonymous victims, this number is a minimum.

**MIN\_UNNAMED** discrete numeric variables, the minimum number of unnamed or anonymous victims involved in the event.

**IRR\_UNNAMED** dichotomous variable, did coders independently agree on the number of unnamed victims involved in the event (1= yes, 0= no).

**V\_GENDER** dichotomous variable, 1= male, 0= female.

**V\_BDATE** discrete numeric variable, four digit year when the victim was born.

**V\_AGE** continuous numeric variable, age of the victim at the time of the event.

**V\_EDUC** ordinal variable. This variable is not reported for El Salvador.

1= no formal education

2= some beginning level of formal education

3= some level of primary education

4= some level of secondary education

5= some level of university or technological education

**V\_LITERACY** dichotomous variable, can the victim read and write (1= yes, 0= no). This variable is not reported for El Salvador.

**V\_MARITAL** categorical variable. The marital status of the victim at the time of the event.

- 1= single
- 2= married or partnered
- 3= separated or divorced
- 4= widowed

**V\_RELIGION** categorical variable. The religion that the victim practiced at the time of the event. This variable is not reported for El Salvador.

- 1= Catholic
- 2= Evangelical
- 3= Other religion
- 4= Atheist

**V\_LANG** categorical variable. The language(s) that the victim spoke at the time of the event. This variable is not reported for El Salvador.

- 1= Spanish only
- 2= Quechua only
- 3= Spanish and Quechua
- 4= Other native language
- 5= Other non-native language

**V\_OCCUP** categorical variable. The job(s) that the victim had at the time of the event.

- 1= Farmer
- 2= Merchant or small businessperson
- 3= Teacher or university professor
- 4= Housewife
- 5= Worker
- 6= Laborer
- 7= Professional or intellectual
- 8= Member of the state armed forces
- 9= Student
- 11= Other
- 12= Unemployed

**V\_ORG** categorical variable. The social, religious or political organization(s) that the victim belonged to at the time of the event.

| PERU                                                | EL SALVADOR                                         |
|-----------------------------------------------------|-----------------------------------------------------|
| 1= Human rights group                               | 1= Human rights group                               |
| 2= Agricultural cooperative or peasant organization | 2= Agricultural cooperative or peasant organization |
| 3= Development or assistance organization           | 3= Development or assistance organization           |
| 4= Community self-defense groups                    | 4= Political party                                  |
| 5= Political party                                  | 5= Labor union                                      |
| 6= Labor union                                      | 6= Student organization                             |

7= Student organization  
 8= Neighborhood organization or parents' association  
 9= Recreational organization  
 10= Religious organization  
 98= MRTA  
 99= SL-PCP

7= Religious organization  
 8= Other organization  
 99= Guerrilla organization

**V\_OTHER** categorical variable, other political identity ascribed to the victim.

**PERU**

1= Accused of any form of participation in any armed subversive organization  
 2= Accused by the Shining Path of being a traitor, informant or of being against the party  
 3= Accused of any form of participation in the trafficking of narcotics  
 4= Denounced, investigated, reported on or tried to prevent human rights violations  
 5= Denounced by someone in the community as a terrorist or subversive  
 6= Labeled by the Shining Path as an adulterer, murderer, rapist, thief or other "undesirable"  
 7= Friend or family member accused or actual member of any terrorist or subversive organization

**EL SALVADOR**

1= Accused of being a member of any armed subversive organization  
 2= Accused of collaborating with any armed subversive organization  
 3= Friend or family member accused of being a member of or collaborating with any armed subversive organization  
 4= Denounced, investigated, reported on or tried to prevent human rights violations  
 5= Denounced by someone in the community as a member of an armed subversive organization  
 6= Accused of other political crimes  
 7= Accused of common crimes  
 8= Accused of deserting the military

**E\_DATE** discrete numeric variable, ranging from 1-31. The day of the month on which the event occurred.

**E\_MONTH** discrete numeric variable, ranging from 1-12. The month in which the event occurred.

**E\_YEAR** discrete numeric variable, ranging from 1978-2003. The year in which the event occurred.

**E\_LOC** categorical variable, the *exact* location where the violation was perpetrated. In cases of detention or kidnapping, this field refers to the point of capture.

1= private residence  
 2= farm  
 3= community plaza, in front of other residents of the village

- 4= state-run detention facility
- 5= school or church
- 6= reasonably presumable public place (not including those otherwise coded). This may include a marketplace, at a sports game or a public, commercial building like a restaurant or bar.
- 7= reasonably presumable private place (not including those otherwise coded). This may include a beach at night, below a bridge, in the woods or mountains surrounding the community.
- 8= rebel base

**PRIVATE** dichotomous variable. Based on the exact location where the violation was perpetrated, did it occur in public or private (1= yes, 0= no). A private space is understood as one in which it is reasonable to presume that no one else was present or witnessed the attack.

**INTERROG** categorical variable

- 1= the violation occurred while the victim was being interrogated, questioned or pressed for information on the opposition
- 2= the violation occurred while the victim was being coerced or forced verbally confess or sign a written statement of culpability, but no effort was made on the part of the perpetrators to acquire additional information on the opposition
- 3= the violation occurred while the victim was *both* being interrogated for information but also coerced to verbally confess or sign a written statement of culpability
- 0= there was no mention of interrogation or attempts to coerce a confession in the description of the violation

**E\_DEPT** categorical variable, department where the event occurred.

| PERU              | EL SALVADOR      |
|-------------------|------------------|
| 1= Amazonas       | 1= Ahuachapán    |
| 2= Ancash         | 2= Cabañas       |
| 3= Apurímac       | 3= Chalatenango  |
| 4= Arequipa       | 4= Cuscatlán     |
| 5= Ayacucho       | 5= La Libertad   |
| 6= Cajamarca      | 6= La Paz        |
| 7= Cusco          | 7= La Unión      |
| 8= Huancavelica   | 8= Morazán       |
| 9= Huánuco        | 9= San Miguel    |
| 10= Ica           | 10= San Salvador |
| 11= Junin         | 11= San Vicente  |
| 12= La Libertad   | 12= Santa Ana    |
| 13= Lambayeque    | 13= Sonsonate    |
| 14= Lima          | 14= Usulután     |
| 15= Loreto        |                  |
| 16= Madre de Dios |                  |

- 17= Moquegua
- 18= Pasco
- 19= Piura
- 20= Puno
- 21= San Martin
- 22= Tacna
- 23= Tumbes
- 24= Ucayali

**PREV\_VIOL** dichotomous variable, prior to the current violation, did the victim suffer any violation of his/her human rights (1= yes, 0=no)

**FF\_VIOL** dichotomous variable, prior to the current case, was a friend, family member or loved one the victim of human rights abuse (1= yes, 0=no).

**WITNESS** dichotomous variable, prior to the current case, did the victim ever witness a human rights crime (1= yes, 0= no).

**MIN\_PERP** discrete numeric variable, the minimum number of perpetrators involved in or present during the commission of the violation.

**P\_NAME** string variable, names of any individuals involved in or present during the commission of the violation, separated by commas.

**COMMAND** string variable, names of any commanding officers involved in or present during the commission of the violation, separated by commas.

**P\_ORG** categorical variable, the state or non-state armed group(s) to which the perpetrator belongs.

| PERU                                                                              | EL SALVADOR                        |
|-----------------------------------------------------------------------------------|------------------------------------|
| 1= Army                                                                           | 1= Army                            |
| 2= Police, including the PIP, GR, and GC                                          | 2= Police                          |
| 3= Specialized counter-terrorism police, including the SINCHIS, DINCOTE, and SUAT | 3= National Guard                  |
| 4= Unspecified military or state armed forces                                     | 4= Treasury Police                 |
| 5= Community self-defense groups                                                  | 5= Civil Defense                   |
| 6= Paramilitaries and death squads                                                | 6= Air Force                       |
| 7= Navy                                                                           | 7= Navy                            |
| 8= Air Force                                                                      | 8= Paramilitaries and death squads |
| 9= Civilian                                                                       | 9= Civilian                        |
| 10= Prison staff or guards                                                        | 10= Foreign militaries             |
| 11= Unknown armed persons                                                         | 11= Unspecified armed persons      |
| 96= Unspecified subversives                                                       | 99= Guerrillas                     |

97= Asháninka army  
98= MRTA  
99= SL-PCP

**P\_WEAPON** categorical variable, the type of weapon(s) used during the commission of the violation.

- 1= firearm
- 2= explosive device
- 3= rudimentary weapons such as sticks, rocks or ropes
- 4= knife or other cutting implement
- 5= water
- 6= electricity
- 7= fire
- 8= penis
- 9= other (includes urine/feces, music, animals)
- 99= unknown arms

**P\_LANG** string variable, any language used by the perpetrator(s) during the commission of the violation.

**DENOUNCE** dichotomous variable, did someone report the violation to a security institution, human rights organization and/or the public prosecutor's office (1= yes, 0= no).

**INVEST** dichotomous variable, if the violation was reported to a security institution, human rights organization or the public prosecutor's office, was it properly investigated (1= yes, 0= no).

---

**CONTESTATION**- department-year count of battles between state armed forces and one or more non-state armed groups. Source: FBIS reports.

**UNI\_MRTA/UNI\_MRTA<sup>2</sup>**- department-year count of unilateral attacks and operations of the MRTA rebel group. Source: FBIS reports.

**UNI\_SL/UNI\_SL<sup>2</sup>**- department-year count of unilateral attacks and operations of the SL rebel group. Source: FBIS reports.

**UNI\_UNKSUBV/UNI\_UNKSUBV<sup>2</sup>**- department-year count of unilateral attacks and operations of unidentified subversive groups. Source: FBIS reports.

**POLITICAL VIOLENCE**- department-year count of reported acts of state-perpetrated political violence. Source: CVR testimonies.

**POPULATION**- the absolute number of people in the population, by household where they reside. Source: Peruvian census records from the National Institute for Statistics and Information.

**≠LITERACY**- the difference in the percentage of women and girls 15 years and older and the percentage of boys and men 15 years and older who can read and write. Source: Peruvian census records from the National Institute for Statistics and Information.

**≠ECONOMIC ACTIVITY**- the difference in the percentage of girls and women 15 years and older and the percentage of boys and men 15 years and older who are economically active. Figures for 1961 and 1981 include men and women ages 6 years and older. Source: Peruvian census records from the National Institute for Statistics and Information.

**+5 KIDS**- the percentage of women 10 years and older who have 5 or more children. Source: Peruvian census records from the National Institute for Statistics and Information.

**APPENDIX E**  
**MODEL VARIATIONS**

| Negative binomial regression |                                       |           |           |                 |                             |
|------------------------------|---------------------------------------|-----------|-----------|-----------------|-----------------------------|
|                              |                                       |           |           |                 | Number of Observations= 407 |
|                              |                                       |           |           |                 | LR chi2(9)= 142.94          |
|                              |                                       |           |           |                 | Prob > chi2= 0.0000         |
|                              |                                       |           |           |                 | Pseudo R2= 0.1463           |
|                              |                                       | Coef.     | Std. Err. | Z               | P> z                        |
| <b>Conflict Variables</b>    | Contestation                          | -.1218485 | .0714916  | -1.70           | 0.088                       |
|                              | Unilateral MRTA Activity              | -.0078373 | .0334728  | <b>-0.23</b>    | 0.815                       |
|                              | Unilateral SL Activity                | .0344804  | .0267243  | <b>1.29</b>     | 0.197                       |
|                              | Unilateral Unspec. Subv. Activity     | -.0159307 | .0130847  | -1.22           | 0.223                       |
| <b>Control Variables</b>     | Population                            | 4.18e-07  | 1.50e-07  | <b>2.79**</b>   | 0.005                       |
|                              | Gender Inequality: Literacy           | -.0282897 | .0232252  | -1.22           | 0.223                       |
|                              | Gender Inequality: Economic Activity  | -.0371017 | .0143488  | <b>-2.59**</b>  | 0.010                       |
|                              | Percentage of Women with >5 Children  | .0721464  | .0482307  | 1.50            | 0.135                       |
|                              | State-Perpetrated Non-Sexual Violence | .0329108  | .0049457  | <b>6.65***</b>  | 0.000                       |
|                              | Constant                              | -5.64451  | 1.289266  | <b>-4.38***</b> | 0.000                       |

**Table E.1 Results, Negative Binomial Regression without Squared Terms ( $Y = \beta_0 + \beta_1X_1 + \beta_2X_2...$ )**

| Negative binomial regression |                                   |           |           |                 |                             |
|------------------------------|-----------------------------------|-----------|-----------|-----------------|-----------------------------|
|                              |                                   |           |           |                 | Number of Observations= 407 |
|                              |                                   |           |           |                 | LR chi2(12)= 132.60         |
|                              |                                   |           |           |                 | Prob > chi2= 0.0000         |
|                              |                                   |           |           |                 | Pseudo R2= 0.1723           |
|                              |                                   | Coef.     | Std. Err. | Z               | P> z                        |
| <b>Conflict Variables</b>    | Contestation                      | .0172307  | .0790372  | 0.22            | 0.827                       |
|                              | Unilateral MRTA Activity          | -.2099984 | .1028422  | <b>-2.04*</b>   | 0.041                       |
|                              | uni_MRTA <sup>2</sup>             | .0070712  | .0024236  | <b>2.92**</b>   | 0.004                       |
|                              | Unilateral SL Activity            | .1481624  | .0413977  | <b>3.58***</b>  | 0.000                       |
|                              | uni_SL <sup>2</sup>               | -.0032292 | .0008185  | <b>-3.95***</b> | 0.000                       |
|                              | Unilateral Unspec. Subv. Activity | -.0377959 | .0349771  | -1.09           | 0.280                       |
|                              | uni_UnkSubv <sup>2</sup>          | .0001365  | .000425   | 0.32            | 0.748                       |
|                              | Political Violence                | 0.259373  | .0046564  | <b>5.57***</b>  | 0.000                       |



|                          |                                       |           |          |                |       |
|--------------------------|---------------------------------------|-----------|----------|----------------|-------|
| <b>Control Variables</b> | Population                            | 3.67e-07  | 1.71e-07 | <b>2.15*</b>   | 0.031 |
|                          | Gender Inequality: Literacy           | -.0254904 | .0245936 | -1.04          | 0.300 |
|                          | Gender Inequality: Economic Activity  | -.0211125 | .0183008 | -1.15          | 0.249 |
|                          | Percentage of Women with >5 Children  | .060712   | .0518905 | 1.17           | 0.242 |
|                          | State-Perpetrated Non-Sexual Violence | 0.259373  | .0046564 | <b>5.57***</b> | 0.000 |
|                          | Constant                              | -5.039175 | 1.504077 | <b>-3.35**</b> | 0.001 |

**Table E.2 Results, Negative Binomial Regression with Restricted Dependent Variable Using ICC Definition of Sexual Violence**

## APPENDIX F

### AGENDA FOR FUTURE RESEARCH IN EL SALVADOR

Because of the constraints on the available data on sexual violence in El Salvador, the first post-doctoral research initiative will require returning to El Salvador between December 2011 and January 2012. The aim of this trip will be to access the denunciations and testimonies of violence collected by the non-governmental *Comisión de Derechos Humanos de El Salvador* (CDHES, Human Rights Commission of El Salvador) and the *Comité de las Madres de los Desaparecidos* (COMADRES, Committee of Mothers of the Disappeared). Based on interviews conducted between January and March 2009, there are good indications that these denunciations include additional information on sexual violence during the civil war. Particularly in the case of the CDHES, which had greater access to prison populations during the conflict, these data may overcome some of the biases found in the records of Tutela Legal and Socorro Jurídico Cristiano. Research assistants will be hired from the *Universidad de El Salvador* and the *Universidad Centroamericana “José Simeón Cañas”* for data collection and data entry tasks.

That said, however, these data are still likely to be limited. Because of the limited gendered development of the human rights agenda at the time of the civil war in El Salvador, it is likely that these records may never give us a complete picture of the occurrence of sexual violence. The greater focus of the time spent in El Salvador will therefore be dedicated to interviewing survivors of the civil war regarding their memories of the conflict. Residents in rural and urban communities, former members of the FMLN and the state armed forces will be interviewed. Prior to leaving for El Salvador, great

time and thought will be devoted to designing an interview strategy that will enable me to elicit the information needed without (re)injuring or traumatizing any of the participants. No questions about any individual's own experiences as a victim/survivor or perpetrator of sexual violence will be asked. Rather, all questions will be framed to discuss what s/he heard or saw during the war. Sample questions might include: *Did you ever hear of someone being sexually abused by the army? Did you ever witness such an attack? Is it possible that soldiers or police officers committed rape or other sexual abuses to torture or interrogate political prisoners?* While contentious, the conflict in El Salvador is likely one of those that requires such a research strategy in order to know with some degree of certainty the level of sexual violence that occurred during the civil war.<sup>189</sup>

I anticipate working closely with scholars who have interviewed and surveyed survivors of political violence as I develop this stage of the research project. In particular, the insights of Dara Cohen of the University of Minnesota who interviewed former combatants of the Revolutionary United Front in Sierra Leone, Peggy Jennings of Women's Rights International, who has experience conducting surveys and interviews with women in conflict situations in Sierra Leone, Liberia and Bosnia-Herzegovina, Inger Skjelsbæk of the Peace Research Institute in Oslo who interviewed victims of sexual violence in Bosnia-Herzegovina and is currently beginning a project to interview those accused of perpetrating these crimes, and Elisabeth Wood of Yale University who has interviewed former and current combatants of non-state armed groups in Colombia and Sri Lanka will be critical to the development of this project.

---

<sup>189</sup> If this research initiative is deemed to be unfeasible because of the difficulty of indentifying individuals willing to speak of their war experiences or unacceptable because of the undue risk and burden to participants, then I will conduct a more exhaustive and comprehensive expert survey with those who worked in the field of human rights during the civil war in El Salvador. Their responses would then be used to indirectly gauge the frequency of sexual violence during the war.

Establishing with greater confidence the frequency with which the state military committed sexual violence during the civil war in El Salvador is essential before completing the final analysis of the book manuscript. This analysis will consist of a comparison of the levels of sexual violence in Peru and El Salvador. The comparison will focus on three factors: (1) the nature of the armed insurgency in each country and the reciprocal relationship between their own perpetration of acts of violence and those of the state, (2) the national discourse and security doctrines employed by each state to frame the opposition, and (3) the international and domestic constraints (in the forms of domestic political institutions, civil society, and domestic and international human rights monitoring agencies) on the state's ability to perpetrate acts of sexual violence. All of the data on the specified independent variables has been collected. However, confirmation of the dependent variable – the relative frequency of wartime sexual violence in Peru and El Salvador – is necessary before the study can be completed.

## REFERENCES

- Agger, Inger and Søren Buus Jensen. "The Psychosexual Trauma of Torture." International Handbook of Traumatic Stress. Eds. John P. Wilson and Beverly Raphael. NY: Plenum Press.
- Allen, Beverly. Rape Warfare: The Hidden Genocide in Bosnia-Herzegovina and Croatia. Minneapolis, MI: University of Minnesota Press, 1996.
- Americas Watch. El Salvador: Impunity Prevails in Human Rights Cases. NY: Americas Watch, 1990.
- Americas Watch. El Salvador: The Massacre at El Mozote, the Need to Remember. NY: Americas Watch, 1992.
- Americas Watch Committee. The Continuing Terror: Seventh Supplement to the Report on Human Rights in El Salvador. NY: Americas Watch Committee, 1985.
- Americas Watch Committee. Human Rights in El Salvador on the Eve of Elections, 1988. NY: Americas Watch Committee, 1988.
- Americas Watch Committee. El Salvador's Decade of Terror: Human Rights since the Assassination of Archbishop Romero New Haven, CT: Yale University Press, 1991.
- Americas Watch Committee and Human Rights Watch. El Salvador. NY: Human Rights Watch, 1990.
- Americas Watch Committee and Human Rights Watch. El Salvador. NY: Human Rights Watch, 1991
- Americas Watch Committee and Human Rights Watch. El Salvador. NY: Human Rights Watch, 1992
- Amnesty International. Amnesty International Report on El Salvador. London: AI, 1982.
- Amnesty International. AI's Continuing Concerns. London: AI, 1991.
- Alison, Miranda. "Wartime Sexual Violence: Women's Human Rights and Questions of Masculinity." Review of International Studies 33.1 (2007): 75-90.
- Anonymous. Personal communication with residents of El Mozote. 28 March 2009.
- Arnson, Cynthia; Neier, Aryeh; and Susan Benda. As Bad as Ever: a Report on Human Rights in El Salvador. NY: Americas Watch Committee, 1984.

- Arrow, Kenneth J. "The Economics of Agency." Report of the Center for Research on Organizational Efficiency Stanford University (1984).
- Ball, Patrick. Who Did What to Whom: Planning and Implementing a Large-Scale Human Rights Data Project. Washington, DC: AAAS, 1996.
- Ball, Patrick; Spierer, Herbert F. and Louise Spierer. Making the Case: Investigating Large Scale Human Rights Violations Using Information Systems Data Analysis. Washington, DC: AAAS, 2000.
- Basombrío, Ernesto de la Jara. Memoria y Batallas en Nombre de los Inocentes: Perú, 1992-2001. Lima, Peru: Instituto de la Defensa Legal, 2001.
- Bernales, Enrique. Violencia y Pacificación: Comisión Especial del Senado sobre las Causas de la Violencia y Alternativas de Pacificación en el Perú. Lima, Peru: DESCO y La Comisión Andina de Juristas, 1989.
- Binford, Leigh. The El Mozote Massacre: Anthropology and Human Rights. Tucson, AZ: University of Arizona Press, 1996.
- Bloom, Mia. "War and the Politics of Rape: Ethnic versus Non-Ethnic Conflicts." Unpublished manuscript, n.d.
- Boesten, Jelke. "Free Choice or Poverty Alleviation? Population Politics in Peru under Alberto Fujimori." European Review of Latin American and Caribbean Studies 82 (2007): 3-20.
- Boesten, Jelke. Intersecting Inequalities: Women and Social Policy in Peru, 1990-2000. University Park, PA: Pennsylvania State University Press, 2009.
- Boesten, Jelke. "Marrying Your Rapist: Domesticating War Crimes in Ayacucho, Peru." Gendered Peace: Women's Search for Post-war Justice and Reconciliation. Ed. Donna Pankhurst. London: Routledge Press, 2007.
- Bracamonte, José Moroni and David E. Spencer. Strategy and Tactics of the Salvadoran FMLN Guerrillas: Last Battle of the Cold War, Blueprint for Future Conflicts. Westport, CT: Praeger Publishers, 1995.
- Brooke, James. "Peru's Poor Feel Hardship of 'Fuji Shock' Austerity." New York Times. 12 August 1990. 23 April 2011.  
<<http://www.nytimes.com/1990/08/12/world/peru-s-poor-feel-hardship-of-fuji-shock-austerity.html>>.
- Brownmiller, Susan. Against Our Will: Men, Women and Rape. London: Penguin Press, 1975.

- Brudney, Victor. "Corporate Governance, Agency Costs, and the Rhetoric of Contract." Columbia Law Review 85.7 (1985):1403-1444.
- Burt, Jo-Marie. "Quién Hablas es Terrorista: The Political Use of Fear in Fujimori's Peru." Latin American Research Review 41.3 (2006): 32-62.
- Burt, Jo-Marie. "Playing Politics with Terror: the Case of Fujimori's Peru." Playing Politics with Terrorism: a User's Guide. Ed. George Kassimeris. NY: Columbia University Press, 2008.
- Burt, Jo-Marie. "Los Usos y Abusos de la Memoria de María Elena Moyano." Contracorriente 7.2 (2010): 165-209.
- Butler, Christopher K; Gluch, Tali and Neil Mitchell. "Security Forces and Sexual Violence: a Cross-National Analysis of a Principal-Agent Argument." Journal of Peace Research 44.6 (2007): 669-687.
- Calkins, Keith. "The Chi Square Frequency Test." n.d. 9 February 2011. <<http://www.andrews.edu/~calkins/math/edrm611/edrm14.htm>>.
- Callamard, Agnés. Documentar las Violaciones de Derechos Humanos por los Agentes del Estado: Violencia Sexual. Montreal, Canada: Centro Internacional de Derechos Humanos y Desarrollo Democrático, 2002.
- Carlson, Eric Stener. "The Hidden Prevalence of Male Sexual Assault during War: Observations of Blunt Trauma to the Male Genitals." British Journal of Criminology 46.1 (2006): 16-25.
- Center for Justice and Accountability (CJA). "Ochoa Lizarbe v. Hurtado, Peru: The Accomarca Massacre." 2008. 20 April 2011. <<http://www.cja.org/section.php?id=22>>.
- Coase, Ronald. "The Nature of the Firm." Economica N.S 4.15 (1937): 386-405.
- Coase, Ronald. "The Problem of Social Cost." Journal of Law and Economics 3 (1960): 1-44.
- Cohen, Dara Kay. "Explaining Sexual Violence during Civil War." Diss. Stanford University, 2010.
- Cohen, Dara Kay. "Explaining Sexual Violence during Civil War: Evidence from Sierra Leone (1991–2002)." Paper presented at the Yale University Workshop on Wartime Sexual Violence, New Haven, CT, 2-4 November, 2007.
- Comando Conjunto de las Fuerzas Armadas del Perú (CCFFAA). Defensa Interior.

DVA N.017 CCFFAA-PE-DI Lima: Peru, 1989.

Comisión para la Verdad y Reconciliación (CVR). Hatun Willakuy: Versión Abreviada del Informe Final de la Comisión de la Verdad y Reconciliación. Lima, Peru: Comisión de Entrega de la Comisión de la Verdad y Reconciliación, 2004.

Comisión para la Verdad y la Reconciliación para el Perú. Informe Final. 2003. 25 February 2010. <<http://www.cverdad.org.pe/ifinal/index.php>>.

Dador Tozzini, Maria Jennie. El Otro Lado de la Historia: Violencia Sexual Contra Hombres, Perú 1980-2000. Lima, Peru: Consejería en Proyectos (PCS), 2007.

De la Cadena, Marisol. Indigenous Mestizos: the Politics of Race and Culture in Cuzco, Peru, 1919-1991. Durham: Duke University Press, 2003.

De Fernandez, JL and C Wurst. "Sexual Violence against Women: Psycho-Juridical Approach." Torture 17.2 (2007): 169-174.

Del Zotto, Augusta and Adam Jones. "Male-on-Male Sexual Violence in Wartime: Human Rights' Last Taboo?" Paper presented at the annual meeting of the International Studies Association, New Orleans, LA. 23-27 March 2002.

Degregori, Carlos Iván and Carlos Rivera Paz. Peru 1980-1993: Fuerzas Armadas, Subversión y Democracia: Redefinición del Papel Militar en un Contexto de Violencia Subversiva y Colapso del Régimen Democrático. Lima, Peru: Instituto Estudios Peruanos, 1993.

Ejército Peruano. Subversión: Ideología y Doctrina, Aplicación por los Movimientos Subversivos en el Perú. Chorrillos, Peru: Ministry of Defense, 1996.

Ejército Peruano. "Grados Militares" n.d. 24 June 2010. <[http://www.ejercito.mil.pe/index.php?option=com\\_content&view=article&id=93&Itemid=39](http://www.ejercito.mil.pe/index.php?option=com_content&view=article&id=93&Itemid=39)>.

Escobar, Loreta Tellería. "Mujer, Fuerzas Armadas y Misiones de Paz: Región Andina." n.d. 29 January 2011. <<http://www.resdal.org/genero-y-paz/mujer-ffaa-misiones-region-andina.pdf>>.

Fein, Helen. "More Murder in the Middle: Life-Integrity Violations and Democracy in the World, 1987." Human Rights Quarterly 17.1 (1995): 170-191.

Ferejohn, John. "Accountability and Authority: Toward a Theory of Political Accountability." Democracy, Accountability and Representation. Eds. Adam Przeworski, Susan Stokes and Bernard Manin. Cambridge: Cambridge University Press, 1999.



- Flores Galindo, Alberto. "The Rebellion of Túpac Amaru." The Peru Reader: History, Culture and Politics. Eds. Orin Starn, Carlos Ivan DeGregori and Robin Kirk. London: Duke University Press, 1995.
- Fumerton, Mario. 2001. "Rondas Campesinas in the Peruvian Civil War: Peasant Self-Defense Organizations in Ayacucho." Bulletin of Latin American Research 20.4 (2001): 470-497.
- García, Ivette Castañeda. "Botas de Color Rosa: Las Mujeres Militares en el Perú." 2006. 20 May 2011. <<http://www.resdal.org/producciones-miembros/art-castaneda-ago06-iidh.html>>.
- Geddes, Barbara. Paradigms and Sandcastles: Theory Building and Research Design in Comparative Politics. Ann Arbor: University of Michigan Press, 2003.
- Ghobarah, Hazem Adam, Huth, Paul and Bruce Russett. "Civil Wars Kill and Maim People – Long After the Shooting Stops." American Political Science Review 97 (2003): 189-202.
- Goertz, Gary. Social Science Concepts: A User's Guide. Princeton: Princeton University Press, 2005.
- Goldstein, Joshua. War and Gender. Cambridge: Cambridge University Press, 2003.
- González-Castañeda, Olga Maria. "Unveiling Secrets of War in the Peruvian Andes." Unpublished manuscript, 2006.
- Goritti, Gustavo Ellenbogen. The Shining Path: a History of the Millenarian War in Peru. Chapel Hill, NC: University of North Carolina Press, 1999.
- Goritti, Gustavo Ellenbogen. "The Quota." The Peru Reader: History, Culture and Politics. Eds. Orin Starn, Carlos Ivan DeGregori and Robin Kirk. London: Duke University Press, 1995.
- Green, Jennifer. "Collective Rape: A Cross-National Study of the Incidence and Perpetrators of Mass Political Sexual Violence, 1980-2003." Diss. Ohio University, 2006.
- Hawkins, Darren G; Lake, David A; Nielson, Daniel L and Michael Tierney, eds. Delegation and Agency in International Organizations: Political Economy of Institutions and Decisions. Cambridge: Cambridge University Press, 2006.
- Hayden, Robert. "Rape and Rape Avoidance in Ethno-Nationalist Conflicts: Sexual Violence in Liminalized States." American Anthropologist 102.1 (2000): 27-41.
- Hayner, Priscilla. "Truth Commissions: A Schematic Overview." International Review

of the Red Cross 88.862 (2006): 295–310.

- Henríquez, Narda. “Gender Studies in Peru.” Women Studies Quarterly 24.1/2 (1996): 364-377.
- Hochschild, Adam. “Rape of the Congo.” New York Review of Books 56.13 (2009).
- Hoover, Amelia. “Disaggregating Violence during Armed Conflict: Why and How?” Unpublished manuscript, 2006.
- Hoover Green, Amelia. “Repertoires of Violence against Non-Combatants: The Role of Armed Group Institutions and Ideologies” Paper presented at the annual meeting of the American Political Science Association, Washington DC, 1-4 September 2011.
- Hubbard, Alan. “Modeling Count – The Poisson and Negative Binomial Regression.” n.d. 9 February 2011. <<http://ehs.sph.berkeley.edu/hubbard/longdata/webfiles/poissonmarch2005.pdf>>.
- Hume, Mo. “It’s as if You Don’t Know, Because You Don’t Do Anything About it”: Gender and Violence in El Salvador.” Environment and Urbanization 16.2 (2004): 63-72.
- Hunnicut, Gwen. “Patriarchy and the Victimization of Women: A Cross-National Exploration of the ‘Degrees of Patriarchy’ and the Violence Victimization of Females” Paper presented at the annual meeting of the American Society of Criminology, Los Angeles, CA. 13 March 2011.
- Instituto de Opinión Pública (IOP). “Fuerzas Armadas, Genero y el Servicio Militar.” 2010. 4 January 2011. <<http://www.scribd.com/doc/27041922/Servicio-Militar-y-Mujeres-en-Las-Fuerzas-Armadas>>.
- Instituto Nacional de Estadística e Informática (INEI). Compendiendo de Estadísticas de la Mujer, 1992. Lima, Peru: Dirección Técnica de Demografía y Estudios Sociales, 1993.
- Instituto Nacional de Estadística e Informática (INEI). La Mujer en el Peru: Características Demográficas, Sociales y Económicas, según los Censos Nacionales de Población y Vivienda. Lima: Dirección Técnica de Demografía y Estudios Sociales, 1995.
- Inter-American Commission on Human Rights (IACHR). Informe N 5/96 Case 10.970 Fernando y Raquel Mejía vs. Peru. Washington, DC: IACHR, 1999.
- International Criminal Court (ICC). “Rome Statute of the International Criminal

- Court, Part 2: Jurisdiction, Admissibility and Applicable Law Article 8(2) (e) (vi) (2000).” 24 May 2011. <<http://untreaty.un.org/cod/icc/index.html>>.
- Isikozlu, Elvan and Ananda S. Millard. “Wartime Rape and Post-Conflict Research.” Bonn International Center for Conversion Bonn, Germany. Unpublished report, 2009.
- Jara, Umberto. Secretos del Túnel: 126 Días de Cautiverio en la Residencia del Embajador del Japón Bogota: Grupo Editorial Norma, 2007.
- Jelin, Elizabeth. State Repression and the Labors of Memory. Minneapolis: University of Minnesota Press, 2003.
- Johnston, Kirsten; Asher, Jana; Rosborough, Stephanie; Raja, Amisha; Panjabi, Rajesh; Beadling, Charles and Lynn Lawry. “Association of Combatant Status and Sexual Violence with Health and Mental Health Outcomes in Postconflict Liberia.” Journal of the American Medical Association 300.6 (2008): 676–90.
- Jubb, Nadine; Camacho, Gloria; D’Angelo, Almachiara; Yanez de la Borda, Gina; Hernández, Katty; Macassi León, Ivonne; MacDowell Santos, Cecília; Molina, Yamileth and Wânia. Regional Mapping Study of Women’s Police Stations in Latin America. Quito, Ecuador: Centro de Planificación y Estudios Sociales, 2008.
- Kalyvas, Stathis. The Logic of Violence in Civil War. Cambridge: Cambridge University Press, 2006.
- Keele, Luke. Semiparametric Regression for the Social Sciences. West Sussex, England: John Wiley & Sons Ltd, 2008.
- King, Gary. “Statistical Models for Political Science Event Counts: Bias in Conventional Procedures and Evidence for the Exponential Poisson Regression Model.” American Journal of Political Science 32 (1988): 838-863.
- King, Gary. “Event Count Models for International Relations: Generalizations and Applications.” International Studies Quarterly 33.2 (1989): 123-147.
- King, Gary; Keohane, Robert and Sidney Verba. Designing Social Inquiry: Scientific Inference in Qualitative Research. Princeton: Princeton University Press, 1994.
- Kirk, Robin. The Monkey’s Paw: New Chronicles from Peru. Boston: University of Massachusetts Press, 1997.
- Kruijt, Dirk and Maria del Pilar Tello. “From Military Reformists to Civilian Dictatorship: Peruvian Military Politics from the 1960s to the Present.” Political Armies: the Military and Nation Building in the Age of Democracy. Eds. Kees Koonings and Dirk Kruijt. London: Zed Books, 2002.

- Landman, Todd and Anita Gohdes. "Principals, Agents, and Atrocities: The Case of Peru 1980-2000." Paper prepared for a meeting on casualty recording and estimation in conflict and post-conflict situations, hosted by Carnegie Mellon University and the University of Pittsburg, Pittsburg, PA. 23-25 October 2009.
- Laplante, Lisa J. and Miryam Rivera Holguin. "The Peruvian Truth Commission's Mental Health Reparations: Empowering Survivors of Political Violence to Impact Public Health Policy." Health and Human Rights 9.2 (2006): 136-163.
- Leiby, Michele. "Wartime Sexual Violence in Guatemala and Peru." International Studies Quarterly 53.2 (2009a): 445-468.
- Leiby, Michele. "Digging in the Archives: the Promise and Perils of Primary Documents." Politics and Society 37.1 (2009b): 75-100.
- Lieberman, Evan S. "Nested Analysis as a Mixed-Method Strategy for Comparative Research." American Political Science Review 99 (2005): 435-452.
- MacKinnon, Catherine. "Reflections on Sex Equality under Law" Yale Law Journal 100 (1991): 1308-1327.
- Manrique, Daniel and David Sulmont. "Preguntas y Críticas Frecuentemente Formuladas sobre las Estadísticas de la Comisión de la Verdad y Reconciliación del Perú." 2007. 24 May 2011. <<http://cifrascvr.wikidot.com>>.
- Marks, Thomas A. and David Scott Palmer. "Radical Maoist Insurgents and Terrorist Tactics: Comparing Peru and Nepal." Low Intensity Conflict and Law Enforcement 13.2 (2005): 91-116.
- Masterson, Daniel M. Militarism and Politics in Latin America: Peru from Sánchez Cerro to Sendero Luminoso. NY: Greenwood Press, 1991.
- McClintock, Cynthia. "The Decimation of Peru's Sendero Luminoso." Comparative Peace Processes in Latin America. Ed. J. Arnson. Washington, DC: Woodrow Wilson Center Press, 1999.
- Merino, Lucero B. Matrimonio y Violación: El Debate del Artículo 178 del Código Penal Peruano. Lima, Peru: Movimiento Manuela Ramos, 1997.
- McCrummen, Stephanie. "Congo's Rape Epidemic Worsens During U.S.-Backed Military Operation." Washington Post Foreign Service 2009.
- Ministerio de Defensa. Libro Blanco de la Defensa Nacional. 1995. 6 April 2011. <<http://www.mindef.gob.pe/>>.

- Mitchell, Neil. Agents of Atrocity: Leaders, Followers, and the Violation of Human Rights in Civil War. New York: Palgrave MacMillan, 2004.
- Montgomery, Tommie Sue. Revolution in El Salvador: From Civil Strife to Civil Peace. Boulder: Westview Press, 1994.
- Moreno-Ocampo, Luis. "Statement of ICC Prosecutor at the Press Conference on Libya." 16 May 2011. 22 May 2011. <<http://www.icc-cpi.int/menus/icc/structure%20of%20the%20court/office%20of%20the%20prosecutor/reports%20and%20statements/statement/statement%20icc%20prosecutor%20press%20conference%20on%20libya%2016%20may%202011?lan=en-GB>>.
- National Security Archive. "Peru: Human Rights, Drugs and Democracy, 1980-2000." Digital National Security Archive and Microfiche set. Ann Arbor, MI: Proquest, 2009.
- Neisser, U. and N. Harsch. "Phantom Flashbulbs: False Recollections of Hearing the News about the Challenger." Affect and Accuracy in Recall: Studies of "Flashbulb" Memories. Eds. E. Winograd and U. Neisser. New York: Cambridge University Press, 1992.
- Páez, Ángel. "Courts Move Closer to Clarifying Accomarca Massacre" IPS. 2008. 20 April 2011. <<http://ipsnews.net/news.asp?idnews=43688>>.
- Palmer, David. "The Shining Path in Peru: Insurgency and the Drug Problem." Low Intensity Conflict: Old Threats in a New World. Eds. Edwin Corr and Stephen Sloan. Boulder, CO: Westview Press, 1992.
- Paniagua, Valentín. "Creación de la Comisión de la Verdad en el Perú." Decreto Supremo No. 065-2001-PCM. Lima, Peru, June 2, 2001.
- Peceny, Mark and William D. Stanley. "Counterinsurgency in El Salvador." Politics and Society 38.1 (2010): 67-94.
- Pérez Guadalupe, José Luis. Faites y Atorrantes: Una Etnografía del Penal de Lurigancho. Lima, Peru: Centro de Investigaciones Teológicas, 1994.
- Portugal, Andrea. "Voices from the War: Exploring the Motivation of Sendero Luminoso Militants." CRISE Working Papers 57 (2008): 4-71.
- Prorok, Alyssa. "Still More Murder in the Middle? A Reassessment of Repression in Mixed Regimes." Paper presented at the annual meeting of the American Political Science Association. Boston, MA 28 August-2 September 2008.
- Regan, Patrick and Errol Henderson. "Democracy, Threats and Political Repression

in Developing Countries: Are Democracies Internally Less Violent?" Third World Quarterly 23.1 (2002): 119-136.

Rennison, Callie Marie. "Rape and Sexual Assault: Reporting to Police and Medical Attention, 1992-2000." Bureau of Justice Statistics 2002. 21 February 2010. <<http://bjs.ojp.usdoj.gov/content/pub/pdf/rsarp00.pdf>>.

Ron, James. Frontiers and Ghettos: State Violence in Serbia and Israel. Berkeley, CA: University of California Press, 2003.

Rowell, Nick. "The Post-Liberation Theology Church, Human Rights and Civil War in Latin America." Paper presented at the Fourth Biennial Symposium on Religion and Politics. Grand Rapids, MI. 24-26 April 2008.

Rozée, Patricia D. "Forbidden or Forgiven? Rape in Cross-Cultural Perspective." Psychology of Women Quarterly 17.1 (1993): 499-514.

Sala Penal Especial de la Corte Suprema (Special Criminal Chamber of the Supreme Court). Barrios Altos, La Cantuta and Army Intelligence Service Basement Cases Case No. AV 19-2001, 2009.

Salarrué. Cuentos de Barro. San Salvador, El Salvador: Consejo Nacional para la Cultura y el Arte, 1999.

Seligson, Mitchell A. and Vincent McElhinny. "Low Intensity Warfare, High Intensity Death: The Demographic Impact of the Wars in El Salvador and Nicaragua." Demographic Diversity and Change in the Central American Isthmus. Eds. Anne R. Pebley and Luis Rosero-Bixby. Santa Monica, CA: Rand Corporation, 1997.

Sharlach, Lisa. "Sexual Violence as Political Terror." Diss., University of California, Davis, 2001.

Sharlach, Lisa. "Rape as Genocide: Bangladesh, the Former Yugoslavia and Rwanda." New Political Science 22.1 (2000): 89-102.

Shryock, Henry; Siegel, Jacob and Elizabeth Larmon. The Methods and Materials of Demography. Washington, DC: U.S. Bureau of the Census, 1980.

Simon, Steve. "Fitting a Quadratic Regression Model." 2008. 22 February 2011. <<http://www.childrens-mercy.org/stats/weblog2006/QuadraticRegression.asp>>.

Sivakumaran, Sandesh. "Male/Male Rape and the 'Taint' of Homosexuality." Human Rights Quarterly 27 (2005): 1274-1306.

Siver, Christi. "The Dark Side of the Band of Brothers: Explaining Variance in War

- Crimes.” Paper presented at the annual meeting of the American Political Science Association. Toronto, Canada, 3-6 September 2009.
- Skelton, Carol and Barry Burkhart. “Sexual Assault.” Criminal Justice and Behavior 7.2 (1980): 229–36.
- Skjelsbæk, Inger. “Sexual Violence and War: Mapping Out a Complex Relationship.” European Journal of International Relations 7.2 (2001): 211-237.
- Skjelsbæk, Inger. “Understanding Perpetrators of Wartime Sexual Violence.” Paper presented at the annual meeting of the International Studies Association, Montreal, Canada, 16-19 March 2011.
- Stanley, William. The Protection Racket State: Elite Politics, Military Extortion, and Civil War in El Salvador. Philadelphia: Temple University Press, 1996.
- Starn, Orin. “Maoism in the Andes: The Communist Party of Peru-Shining Path and the Refusal of History.” Journal of Latin American Studies 27 (1995): 399-421.
- Starn, Orin, ed. Hablan los Ronderos: la Búsqueda por la Paz en los Andes. Lima, Peru: Instituto de Estudios Peruanos, 1993.
- Starn, Orin; Degregori, Carlos Iván and Robin Kirk, eds. The Peru Reader: History, Culture, Politics. Durham, North Carolina: Duke University Press, 1995.
- Stern, Steve, ed. Shining and Other Paths: War and Society in Peru, 1980-1995. Durham, North Carolina: Duke University Press, 1998.
- Stern, Steve. “The Tragedy of Success.” The Peru Reader: History, Culture and Politics. Eds. Orin Starn, Carlos Ivan DeGregori and Robin Kirk. London: Duke University Press, 1995.
- Stiglmeier, Alexandra, ed. Mass Rape: the War against Women in Bosnia-Herzegovina. Lincoln, NE: University of Nebraska Press, 1994.
- Strøm, Kaare. “Delegation and Accountability in Parliamentary Democracies.” European Journal of Political Research 37.3 (2000): 261-290.
- Sulmont, David Haak. “El Tema de Género en Encuestas de Opinión en el Perú.” Unpublished manuscript, 2007.
- Talarico, Jennifer and David Rubin. “Confidence, not Consistency, Characterizes Flashbulb Memories.” Psychological Science (2003).
- Theidon, Kimberly. “Speaking Silences: Common Sense , Gender and War.” Paper

presented at the Workshop on Sexual Violence during War at Yale University, 2-4 November 2007.

Toledo, Alejandro. "Creación de la Comisión de la Verdad en el Perú." Decreto Supremo No. 101-201-PCM. Lima, Peru, 31 August 2001.

Tutela Legal. El Mozote: Lucha por la Verdad y la Justicia: Masacre a la Inocencia San Salvador, El Salvador: Tutela Legal del Arzobispado de San Salvador, 2008.

UCLA Academic Technology Services. "Stata Data Analysis Examples: Zero-inflated Negative Binomial Regression." n.d. 25 May 2011. <<http://www.ats.ucla.edu/stat/stata/dae/nbreg.htm>>.

Ugalde, Antonio; Selva-Sutter, Ernesto; Castillo, Carolina; Paz, Carolina and Sergio Cañas. "The Health Costs of War: Can They Be Measured? Lessons from El Salvador." British Medical Journal 321.169 (2000).

United Nations Commission of Experts Established Pursuant to Security Council Resolution 780. UN Doc S/1994/674/Add.2 (Vol. V). Annex IV, Rape and Sexual Assault. New York: United Nations, 1992.

United Nations Security Council (UNSC). 55<sup>th</sup> Session, 4213<sup>th</sup> meeting, UN DOC S/RES/1325. New York: United Nations, 2000.

United Nations Security Council (UNSC). 5916<sup>th</sup> meeting, UN DOC S/RES/1820. New York: United Nations, 2008.

United Nations. *Convention against Torture and Other Cruel, Inhuman or Degrading Treatment or Punishment* New York: United Nations. 1994. 25 February 2010. <<http://www.hrweb.org/legal/cat.html>>.

United Nations. United Nations Document UN E/CN.4/1992/SR.21 New York: United Nations, 1999.

United Nations High Commissioner for Refugees. "El Salvador: Information on the Mariona Prison, Formally Named La Esperanza, in San Salvador." 2001. 27 April 2011. <<http://www.unhcr.org/refworld/country,,USCIS,,SLV,,3decde994,0.html>>.

United States Army. Report of the El Salvador Military Strategy Assistance Team. US Army Declassified Document in Author's Possession. San Salvador, El Salvador, 1981.

Uppsala Conflict Data Program. UCDP Database. 2011. 19 March 2011. <[www.ucdp.uu.se/database](http://www.ucdp.uu.se/database)>.



- Valencia-Weber, Gloria and Robert J. Weber. "El Salvador: Methods Used to Document Human Rights Violations." Human Rights Quarterly 8.4 (1986): 731-770.
- Valenius, Johanna. "Living in an Over-Organized Jungle: Military Discipline, Masculinity and Rape in Casualties of War." Paper presented at the 45<sup>th</sup> annual International Studies Association meeting, Montreal, Canada 17-20 March 2004.
- Valentino, Benjamin. Final Solutions: Mass Killing and Genocide in the 20<sup>th</sup> Century. NY: Cornell University Press, 2004.
- Wang, T. Y.; Dixon, William J; Muller, Edward N. and Mitchell A. Seligson. "Inequality and Political Violence Revisited." American Political Science Review 87.4 (1993): 977-994.
- Webb, Richard and Graciela Fernández Baca. Peru '95 en Números: Anuario Estadístico. 1995
- Weingast, Barry R. "The Congressional-Bureaucratic System: A Principal-Agent Perspective (with Applications to the SEC)." Public Choice 44.1 (1984): 147-191.
- Weingast, Barry and W. Marshall. "The Industrial Organization of Congress; or, Why Legislatures, Like Firms, Are Not Organized as Markets." Journal of Political Economy 96 (1988): 132-163.
- Weismantel, Mary. Cholas and Pishtacos: Stories of Race and Sex in the Andes. Chicago: University of Chicago Press, 2001.
- Wood, Elisabeth. Insurgent Collective Action and Civil War in El Salvador. NY: Cambridge University Press, 2003.
- Wood, Elisabeth. "Variation in Wartime Sexual Violence." Politics and Society 34.3 (2006): 307-341.
- Wood, Elisabeth. "Armed Groups and Sexual Violence: When is Wartime Rape Rare?" Politics and Society 37.1 (2009): 131-162.
- Wood, Elisabeth. "Sexual Violence during War: Variation and Accountability." Collective Crimes and International Criminal Justice: An Interdisciplinary Approach. Eds. Alette Smeulers and Elies van Sliedregt. Antwerp: Intersentia, 2010.
- Wood, Reed M. "Rebel Capacity and Strategic Violence against Civilians." Journal of Peace Research 47.5 (2010): 601-614.
- Yodanis, Carrie. L. "Gender Inequality, Violence against Women and Fear: A Cross-

National Test of the Feminist Theory of Violence against Women.” Journal of Interpersonal Violence 19.6 (2004): 655-675.

Zarkov, Dubrakva. “Sexual Violence and War in the Former Yugoslavia” Speech made at the Cordaid Debate on Gender-based War Crimes: A Future after Humiliation. 11 January 2005. 10 January 2010.  
<[http://www.cordaid.nl/Overice/Extra\\_pop\\_up/Index.aspx?mid=9593&sid=292](http://www.cordaid.nl/Overice/Extra_pop_up/Index.aspx?mid=9593&sid=292)>.