

9-12-2014

White matter integrity and alcohol use disorders

Mollie Monnig

Follow this and additional works at: https://digitalrepository.unm.edu/psy_etds

Recommended Citation

Monnig, Mollie. "White matter integrity and alcohol use disorders." (2014). https://digitalrepository.unm.edu/psy_etds/97

This Dissertation is brought to you for free and open access by the Electronic Theses and Dissertations at UNM Digital Repository. It has been accepted for inclusion in Psychology ETDs by an authorized administrator of UNM Digital Repository. For more information, please contact disc@unm.edu.

Mollie A. Monnig

Committee

Psychology

Department

This dissertation is approved, and it is acceptable in quality and form for publication:

Approved by the Dissertation Committee:

Ronald A. Yeo, PhD, Chairperson



Kent E. Hutchison, PhD



Barbara S. McCrady, PhD

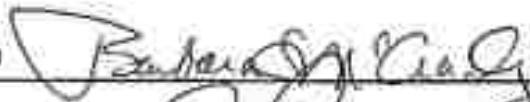

J. Scott Tonigan, PhD



Robert J. Thoma, PhD



**WHITE MATTER INTEGRITY AND
ALCOHOL USE DISORDERS**

by

MOLLIE A. MONNIG

B.A., English, Amherst College, 2004
M.S., Psychology, University of New Mexico, 2010

DISSERTATION

Submitted in Partial Fulfillment of the
Requirements for the Degree of
Doctor of Philosophy

Psychology

The University of New Mexico
Albuquerque, New Mexico

May, 2014

ACKNOWLEDGMENTS

I wish to thank the members of my dissertation committee, Dr. Ronald A. Yeo (chair), Dr. Kent E. Hutchison, Dr. Barbara McCrady, Dr. J. Scott Tonigan, and Dr. Robert J. Thoma, for their contributions and insights on this project as well as those that led to its inception. Support for this project was received from National Institute on Alcohol Abuse and Alcoholism individual predoctoral fellowship 1F31AA021631 (PI: Monnig) and from institutional training grant T32AA01818-01 through the Center on Alcoholism, Substance Abuse, and Addictions (PI: McCrady). Data were collected under NIAAA grants 5R01AA012238 and 5R01AA014886 (PI: Hutchison).

WHITE MATTER INTEGRITY IN ALCOHOL USE DISORDERS

by

Mollie A. Monnig

B.S, English, Amherst College, 2004

M.S., Psychology, University of New Mexico, 2010

Ph.D., Psychology, University of New Mexico, 2014

ABSTRACT

Injury to the brain's white matter is a signature injury of alcohol use disorders (AUD), yet research on its causes and correlates has yielded mixed findings. This study used structural equation modeling (SEM) to test associations between clinical and demographic factors and variability in white matter integrity in heavy drinkers (mean age = 30.86 ± 9.08 years; 30% female; 62% treatment-naïve). Magnetic resonance imaging scans, including diffusion tensor imaging (DTI), were collected from 324 individuals who reported recent heavy drinking (at least 5 binge-drinking episodes in the past 30 days, or > 14 standard drinks/week for women and > 21 standard drinks/week for men). Drinking history, alcohol problem severity, and cognitive functioning also were assessed. A latent factor representing white matter integrity was created from DTI metrics of 8 white matter regions of interest associated with alcohol cue reactivity in a previous study (Monnig et al., under review). Mediation of the path from duration of drinking to this white matter integrity factor (WMIF) by problem severity and drinking history variables

was tested using SEM. Moderated mediation by gender, treatment-seeking status, smoking status, and comorbidity then was tested. Results showed that problem severity and frequency of drinking partially mediated the path from number of years drinking to WMIF, with both mediators contributing to lower WMIF scores. In addition, gender moderated the indirect path through frequency of drinking, with more frequent drinking linked to lower WMIF scores in women but not men. WMIF was significantly, positively associated with visuospatial ability in the entire sample. WMIF partially mediated the path from duration of drinking to visuospatial scores. Treatment-seeking status moderated the effect such that treatment-seeking but not treatment-naïve individuals showed a positive association between WMIF scores and visuospatial ability. Finally, an exploratory analysis found preliminary support for the hypothesis that white matter integrity impacts drinking intensity through subjective loss of control over drinking. Investigating the association of heavy drinking with variability in white matter integrity is a novel application of SEM. This study contributes to understanding of how drinking behavior and individual differences relate to integrity of white matter networks implicated in AUD.

TABLE OF CONTENTS

LIST OF TABLES.....	viii
LIST OF FIGURES.....	ix
INTRODUCTION.....	1
BACKGROUND.....	5
Advances in magnetic resonance imaging of white matter.....	5
White matter damage as a signature injury of AUD.....	6
Individual differences that may influence white matter damage in AUD.....	10
Influence of white matter integrity on cognitive and functional outcomes.....	18
METHOD.....	21
Participants.....	21
Diagnostic testing.....	22
Medical lab testing.....	23
DTI protocol.....	24
Selection of DTI variables.....	26
Statistical analysis.....	30
RESULTS.....	41
Descriptive statistics.....	41
CFA.....	45
Simple mediation.....	49
Multiple mediation.....	51
Mediation by latent variables.....	55
Moderated mediation.....	56

WMIF and cognitive functioning.....	63
Exploratory analysis.....	68
DISCUSSION.....	71
Primary findings.....	71
White matter integrity and cognition.....	76
Loss of control over drinking.....	78
Limitations.....	79
Conclusions.....	83
REFERENCES.....	87

LIST OF TABLES

Table 1. List of abbreviations used in this manuscript	4
Table 2. Descriptive statistics for participants with data for WMIF and NYD.....	41
Table 3. Bivariate correlations for participants with NYD data.....	43
Table 4. Descriptive statistics by moderating variables.....	44
Table 5. Descriptive statistics for FA values of white matter ROIs.....	45
Table 6. CFA results.....	46
Table 7. Simple mediation of the path from NYD to WMIF.....	50
Table 8. Multiple mediation of the path from NYD to WMIF.....	53
Table 9. Mediation by latent variables.....	56
Table 10. Selected results of moderated mediation.....	58

LIST OF FIGURES

Figure 1. ROIs included in the model of white matter integrity.....	29
Figure 2. Simultaneous view of ROIs in the model of white matter integrity.....	30
Figure 3. Simple mediation model.....	35
Figure 4. Measurement model of the white matter integrity factor (WMIF)	47
Figure 5. Partial multiple mediation of the path from NYD to WMIF by ADS and DPDD.....	55
Figure 6. Relation between ADS and WMIF score by gender.....	60
Figure 7. Relation between PDD and WMIF score by gender.....	62
Figure 8. Relation between Matrix Reasoning score and WMIF score by treatment- seeking status.....	65
Figure 9. Three models of drinking history, white matter integrity, and visuospatial functioning.....	67
Figure 10. Full mediation of the path from WMIF to DPDD by ICS.....	69

Introduction

Transdisciplinary integration of neurophysiological, behavioral, and psychological data is leading to advances in understanding of the development, maintenance, and consequences of alcohol use disorders (AUD; Table 1 lists all abbreviations used in this manuscript). Predominant neuroscientific models of AUD posit an imbalance between top-down cortical control networks and subcortical networks of motivation and reward, leading to impaired insight and compulsive drug-seeking behavior (Koob & Volkow, 2010). White matter tracts, which form the connective structure enabling communication among neurons, are a critical element in this conceptualization.

White matter damage is a hallmark injury of AUD, with substantial volume loss found in both postmortem and in vivo studies (Kril & Halliday, 1999; M. A. Monnig, Tonigan, Yeo, Thoma, & McCrady, 2012; Oscar-Berman & Marinković, 2007; E. V. Sullivan, 2000). Although volumetric studies have been useful in establishing the magnitude of the problem, only recently have neuroimaging advances enabled more thorough investigation of white matter networks with diffusion tensor imaging (DTI). DTI, an application of magnetic resonance imaging (MRI), quantifies integrity of white matter using principles of water diffusion, yielding richer information than simple volumetric measures. DTI metrics have been shown to reflect axonal health and myelination (Beaulieu, 2002; Pierpaoli et al., 2001; Song et al., 2003; Song et al., 2002; Song et al., 2005). Several DTI studies have demonstrated abnormality of reward and self-regulation networks in individuals with AUD (Harris et al., 2008; M. A. Monnig, Tonigan, et al., 2012; Pfefferbaum, Rosenbloom, Rohlfing, & Sullivan, 2009; Yeh,

Simpson, Durazzo, Gazdzinski, & Meyerhoff, 2009), indirectly supporting the theory that addiction arises from dysfunction of these networks. In the context of psychosocial treatment for AUD, damage to these networks may be problematic for interventions that rely on self-reflection, effortful information processing, and reevaluation of reward.

Important as previous studies have been in documenting white matter abnormality, relations between white matter integrity and AUD symptoms, drinking behavior, physical health, and potential moderators have yet to be comprehensively investigated. This study was guided by a conceptual framework proposing that heavy alcohol use over time causes alterations to white matter networks that include structural damage, most likely resulting from oxidative stress, as well as neuroadaptation (Crews & Nixon, 2008; Koob & Volkow, 2010). Neuroadaptation is thought to occur in response to damage to white matter fibers and gray matter cell bodies and in parallel with behavioral and psychological manifestations of problem drinking, such as preoccupation with alcohol, craving, and compulsive use despite negative consequences. Ongoing exposure to high blood alcohol levels compromises brain substrates of reward and self-regulation, potentially creating a cycle of problem drinking.

The current study examined the association of white matter integrity with psychological, behavioral, and physiological AUD variables in a representative sample of 324 heavy drinkers. Because the cross-sectional study design limited testing of causal chains proposed in the conceptual model described above, a working model was designed to test the plausibility of hypothesized relations as a preliminary step to longitudinal investigation. In the main analyses, chronicity of drinking served as a proxy for the individual's expected level of oxidative stress activated by alcohol exposure, and the

effects of other AUD variables on white matter integrity were tested in conjunction with this predictor. The three major aims were as follows:

1. The first aim identified which variables from problem severity questionnaires, measures of drinking history, and physiological tests were associated with lower white matter integrity using a latent variable modeling framework. A latent variable was formed to represent a white matter integrity factor (WMIF). Each variable of interest was tested as a mediator of the relation between duration of drinking and WMIF. Following identification of key markers, the relative and unique predictive power of each marker was evaluated in a multiple mediation model. In short, the objective was to determine which variable or variables best predicted white matter integrity, controlling for the effects of other variables.
2. An ongoing question in AUD research is whether sample characteristics such as gender, treatment-seeking status, comorbidity, and smoking status are potential moderators or confounds of associations between AUD variables and brain structure. The second aim investigated these characteristics as moderators of the relation between duration of drinking and WMIF. Moderated mediation models tested whether mediators identified in the first aim functioned comparably across subpopulations.
3. The third aim examined the functional correlates of white matter integrity in the area of cognitive performance. Direct associations between WMIF and cognitive domains were assessed, and WMIF then was tested as a mediator of the path from duration of drinking to cognitive functioning.

Table 1. List of abbreviations used in this manuscript.

Abbreviation	Meaning
ADS	Alcohol Dependence Scale
ALP	Alkaline phosphatase
ALT	Alanine aminotransferase
AST	Aspartate aminotransferase
AUD	Alcohol use disorder
AUDIT	Alcohol Use Disorder Identification Test
BAI	Beck Anxiety Inventory
BCC	Body of corpus callosum
BDI	Beck Depression Inventory
BMI	Body mass index
CFA	Confirmatory factor analysis
CFI	Comparative fit index
CGR	Cingulate gyrus, right
CGL	Cingulate gyrus, left
CI	Confidence interval
DTI	Diffusion tensor imaging
ECR	External capsule, right
ECL	External capsule, left
FA	Fractional anisotropy
fMRI	Functional magnetic resonance imaging
FNX	Fornix
GGT	Gamma-glutamyl transpeptidase
GM	Gray matter
ICS	Impaired Control Scale
LDH	Lactate dehydrogenase
MCV	Mean corpuscular volume
NYD	Number of years drinking
PDD	Percentage days drinking
PHDD	Percentage days heavy drinking
RMSEA	Root-mean-square error of approximation
ROI	Region of interest
SEM	Structural equation modeling
SLFR	Superior longitudinal fasciculus, right
SLFL	Superior longitudinal fasciculus, left
SRMR	Standardized root mean square residual
WASI	Wechsler Abbreviated Scale of Intelligence
WMIF	White matter integrity factor

Background

Advances in magnetic resonance imaging of white matter

Forming the connective structure among the brain's 100 billion neurons, white matter constitutes roughly half the tissue volume of the brain and is composed of myelinated axons, glial cells, and the supporting vasculature (Filley, 2001). White matter derives its name from the appearance of myelin, a fatty sheath that insulates axons, speeding propagation of nerve impulses by as much as 100 times (Kandel, Schwartz, & Jessell, 2000). White matter fibers organized into discrete neuroanatomical units are known as tracts and can be classified into three broad categories. Commissural tracts, the most prominent of which is the corpus callosum, connect the left and right cerebral hemispheres; association tracts, such as the cingulum, comprise intrahemispheric connections; and projection tracts, such as corticothalamic fibers, link cortical regions with brainstem and subcortical structures (Filley, 2001).

The role of white matter in fundamental motor and sensory functions has long been recognized, yet white matter has drawn widespread attention in the study of cognitive and psychiatric disorders only recently. Neuropsychological profiles associated with diseases primarily affecting white matter have prompted reevaluation of the role of cerebral white matter in higher-order cognitive functions traditionally ascribed to the brain's gray matter [GM (Filley, 2001)]. For example, multiple sclerosis, a disease involving diffuse demyelination, entails not only sensory and motor impairment but also executive dysfunction, memory impairment, and neuropsychiatric symptoms including depression and personality changes (Filley, 2001).

Improved neuroimaging methods such as DTI facilitate assessment of subtler forms of white matter abnormality than gross lesions or atrophy. DTI allows for inferences about the health of white matter to be made non-invasively based on the principle of Brownian motion of water molecules (Basser & Pierpaoli, 1996). In general, optimal myelination and organization of fibers results in increased directionality of water diffusion within white matter microstructure. The extent to which diffusion in a voxel is non-random, or anisotropic, is quantified in terms of fractional anisotropy (FA), a value ranging from 0, which corresponds to unrestricted diffusion, to 1, indicative of diffusion along a single axis. FA is believed to reflect multiple properties of white matter microstructure, including axonal diameter, axonal density, and myelination (Beaulieu, 2002; Pierpaoli, et al., 2001; Song, et al., 2003; Song, et al., 2002; Song, et al., 2005); it often is reported as a summary index of white matter integrity. The component metrics from which FA is calculated are axial diffusivity and radial diffusivity. Axial diffusivity represents the magnitude of diffusion parallel to the tensor (i.e., in the primary directional orientation of the white matter fiber tract), and radial diffusivity represents diffusion perpendicular to this tensor. A decrease in FA can be caused by an decrease in axial diffusivity, indicating axonal injury, or by an increase in radial diffusivity, usually associated with dysmyelination of white matter fibers (Harsan et al., 2006; Song, et al., 2003; Song, et al., 2002; Song, et al., 2005).

White matter damage as a signature injury of AUD

Converging evidence from neuropathological, neuroimaging, and neuropsychological investigations of AUD implicates white matter dysfunction in the pathophysiology of AUD (Kril & Halliday, 1999; Oscar-Berman & Marinković, 2007; E.

V. Sullivan & Pfefferbaum, 2005). Approximately 30% of the United States population will meet criteria for AUD at some point in the lifetime (Hasin, Stinson, Ogburn, & Grant, 2007), making alcohol-related brain damage a pressing public health concern.

Postmortem studies of alcohol dependence without Wernicke-Korsakoff syndrome have found a 3% reduction of cerebral white matter without a commensurate loss of GM, relative to healthy, matched control cases (Harper & Corbett, 1990). Studies also have found down-regulation of genes associated with myelination in the frontal cortex (Lewohl et al., 2000; Liu, Lewohl, Harris, Dodd, & Mayfield, 2007).

A meta-analysis of MRI studies ($N = 19$) comparing white matter volume in AUD and control groups found a small-to-medium effect size for white matter reduction in AUD [Hedges' $g = .304$; (M. A. Monnig, Tonigan, et al., 2012)]. Thus, AUD diagnosis is associated with a modest but significant deficit in white matter volume. As the majority of studies of white matter volume in AUD have been cross-sectional, smaller white matter volumes could reflect atrophy caused by chronic alcohol abuse, premorbid differences, or the influence of a non-AUD variable.

Because DTI can detect abnormality prior to the onset of measureable atrophy (Fjell et al., 2008; Giorgio et al., 2010), it can be used to examine early alcohol-related damage in white matter networks. DTI studies of AUD individuals with several months of abstinence have reported white matter abnormality in corpus callosum (Pfefferbaum, Adalsteinsson, & Sullivan, 2006; Pfefferbaum et al., 2000), as well as fornix, internal and external capsule, and superior longitudinal fasciculus (Pfefferbaum, et al., 2009). Another study of AUD individuals with one week of abstinence found lower FA in external capsule, anterior and superior corona radiata, and thalamus (Yeh, et al., 2009).

When DTI was used to characterize white matter integrity as a function of abstinence, white matter profiles differed as a function of drinking status (M. A. Monnig et al., 2012). This study compared healthy control participants ($n = 15$) to individuals with current AUD ($n = 10$) and individuals with AUD in remission for at least one year ($n = 9$). The primary finding in currently drinking individuals was abnormal diffusivity parallel to the axonal bundle in bilateral frontal and temporal white matter, whereas individuals with remitted AUD showed FA reductions in bilateral parietal regions. These results could be interpreted as selective damage to frontolimbic circuitry in acute stages of dependence and either premorbid abnormality or enduring impairment of parietal networks in individuals with sustained abstinence.

Taken together, previous DTI studies suggest that alcohol-related white matter damage occurs in all three types of white matter tracts (i.e., commissural, association, and projection fibers) and that it may preferentially affect networks subserving emotional and cognitive functioning. Neuropsychological profiles of AUD finding impairment in executive function, emotional regulation, memory retrieval, processing speed, and visuospatial processing concur with this supposition (Filley, 2001; Moselhy, Georgiou, & Kahn, 2001; Oscar-Berman & Marinković, 2007).

Exactly how excessive drinking exerts deleterious effects on white matter microstructure remains the topic of intense research in both naturalistic human samples and experimental animal models. Although earlier explanations attributed the bulk of damage to glutamatergic excitotoxicity during withdrawal, newer evidence suggests that alcohol-related brain damage occurs primarily during intoxication through processes of oxidative stress (Crews & Nixon, 2009). Alcohol directly stimulates proinflammatory

cascades, leading to cell dysfunction or death, and inhibits neurogenesis in adult neural stem cells in olfactory bulb and hippocampus (Crews & Nixon, 2009).

Recovery of brain cell structure and function is thought to begin immediately upon cessation of drinking and to continue with sustained abstinence. Longitudinal neuroimaging studies of AUD individuals corroborate recovery of gray and white matter and/or reversal of ventricular dilation with abstinence (Agartz et al., 2003; Bartsch et al., 2007; Cardenas, Studholme, Gazdzinski, Durazzo, & Meyerhoff, 2007; Gazdzinski, Durazzo, & Meyerhoff, 2005; Mann et al., 2005; Muuronen, Bergman, Hindmarsh, & Telakivi, 1989; Pfefferbaum et al., 1995; Shear, Jernigan, & Butters, 1994). Some evidence suggests that white matter may play a more prominent role in tissue recovery than GM (Agartz, et al., 2003; Bartsch, et al., 2007; Shear, et al., 1994). In the meta-analysis of white matter volume in AUD, time since last drink was a significant moderator of white matter volume (M. A. Monnig, Tonigan, et al., 2012). The magnitude of group differences decreased as length of abstinence increased, offering indirect support for white matter regeneration with sustained abstinence. A qualitative review of naturalistic, longitudinal studies of AUD individuals who either relapsed or maintained abstinence over time supported this assertion, as these studies typically reported significant differences in white matter volume as a function of drinking status at follow-up (Agartz, et al., 2003; M. A. Monnig, Tonigan, et al., 2012; Pfefferbaum, et al., 1995; Pfefferbaum, Sullivan, Rosenbloom, Mathalon, & Lim, 1998; Rohlfing, Sullivan, & Pfefferbaum, 2006; Shear, et al., 1994). Although the functional correlates of tissue recovery with abstinence are not well-established, studies have found parallel

improvements in memory, attention, and visuospatial processing (Bartsch, et al., 2007; Muuronen, et al., 1989; E. V. Sullivan, Rosenbloom, Lim, & Pfefferbaum, 2000).

Individual differences that may influence white matter damage in AUD

Gender. A review by Brady and Randall (1999) highlighted gender differences in prevalence and manifestation of substance use disorders. Men are more likely to experience AUD (Grant, Dawson, et al., 2004), yet comorbid depression and anxiety, history of trauma, and social stigmatization are more prevalent for women with AUD (Brady & Randall, 1999). An updated review of gender differences in AUD noted that, while women possess stronger protective factors, they also experience more negative consequences, including medical illness and violence (Nolen-Hoeksema, 2004).

In both women and men, a U-shaped curve best describes the relationship between overall mortality and alcohol consumption, with light-to-moderate levels most protective (Fuchs et al., 1995). Biological differences in alcohol metabolism have been thought to contribute to a “telescoping effect” whereby women experience more severe consequences of heavy drinking within a shorter timeframe (Brady & Randall, 1999; Randall et al., 1999). Studies of clinical samples have determined that although women initiate alcohol use later in life than men, women progress more rapidly from initiation to dependence and subsequently to seeking of treatment (Hernandez-Avila, Rounsaville, & Kranzler, 2004; Randall, et al., 1999; Schuckit, Daepfen, Tipp, Hesselbrock, & Bucholz, 1998). For example, women enrolled in Project MATCH demonstrated more rapid progression from onset of heavy drinking to the experience of drinking-related problems, loss of control over drinking, and first occurrence of seeking treatment (Randall, et al., 1999). On the other hand, a recent analysis of findings from major epidemiological

samples found no evidence for a telescoping effect in the population at large (Keyes, Martins, Blanco, & Hasin, 2010). Instead, the time between initiation of alcohol use to dependence was shorter in men, with the magnitude of the gender difference greater in younger cohorts (Keyes, et al., 2010).

As to physiological consequences, studies have found that alcoholic cirrhosis develops after shorter drinking duration, accompanies lower levels of consumption, and progresses more quickly in women than men (Saunders, Davis, & Williams, 1981). Several CT studies have lent support to a telescoping effect for brain damage in alcohol dependent women. Women with shorter duration of dependence and lower estimated intake than their male counterparts have shown comparable brain atrophy, a finding that persisted even in subsets matched on age and duration of dependence (Jacobson, 1986). A more recent CT study also demonstrated a similar extent of brain atrophy in alcohol-dependent women and men, even though average duration of dependence in women, at 5.6 years, was only about half that reported by men, at 10.4 years (Mann, et al., 2005). This study closely replicated an earlier study performed by the same group in an independent sample (Mann, et al., 2005; Mann, Batra, Günthner, & Schroth, 1992). An MRI study of corpus callosum reported a sizable reduction in area in female but not male alcohol-dependent inpatients with equivalent duration of dependence and drinking levels (Hommer et al., 1996).

Other researchers have strongly questioned the existence of a telescoping effect for alcohol-related brain damage. Numerous studies have failed to find evidence of greater damage in women, and some studies have found that women have shown lesser damage even when controlling for or matching gender groups on intake and duration

(Pfefferbaum, et al., 2006; E. V. Sullivan, Rohlfing, & Pfefferbaum, 2010). When tested as a moderator of white matter volume in the meta-analysis, gender did not have a significant effect (M. A. Monnig, Tonigan, et al., 2012). However, the small number of studies including women limited power to detect effects, and the effect size for female-only studies ($g = .538$) was non-significantly larger than the effect size for male-only studies ($g = .239$).

Establishing gender differences in alcohol-related white matter damage is complicated by the presence of normal gender differences in white matter integrity of various tracts. One study found higher FA in left superior longitudinal fasciculus in men but higher FA in body of corpus callosum in women (Kanaan et al., 2012). Another study reported that global FA of pericortical white matter was approximately 5% higher in men compared to women (Kang, Herron, & Woods, 2011). In a very large study of healthy adults, men had significantly higher FA in external capsule, cingulum gyrus, and superior longitudinal fasciculus, whereas women had higher FA in the fornix (Inano, et al., 2011).

Comorbidity. In the general population, mood and anxiety disorders occur at higher rates among those with AUD (Hasin, et al., 2007). Among those seeking treatment for AUD, 41% met criteria for a mood disorder and 33% met criteria for an anxiety disorder considered independent from the AUD (Grant, Stinson, et al., 2004).

MRI studies have identified reliable patterns of structural brain differences in major depression and anxiety. A study of depression and anxiety disorders revealed reduction in GM and white matter surrounding the anterior cingulate cortex, with additional GM volume decreases in frontal and temporal regions (van Tol et al., 2010). The neural signature of depression appears to entail volume changes in the medial

prefrontal cortex and in subcortical structures, including hippocampus, amygdala, and basal ganglia (Drevets, Price, & Furey, 2008). A review of post-mortem, neuroimaging, and genetic studies concluded that depression was associated with decreased white matter integrity, increased white matter lesions, and decreased markers of myelination (Tham, Woon, Sum, Lee, & Sim, 2010). Finally, a brain-based endophenotype for familial depression has been proposed that involves right-hemisphere GM reductions and disrupted frontal and parietal white matter connections (Peterson & Weissman, 2011). This endophenotype is noteworthy for its overlap with brain structural changes identified in AUD. Similarly, attention deficit hyperactivity disorder (ADHD) appears to predispose teenagers to earlier onset and higher rates of substance use disorders (B. S. Molina et al., 2013). In adults with childhood ADHD, the cingulum bundle and the superior longitudinal fasciculus, two tracts of interest in the current study, showed lower white matter integrity (Makris et al., 2008).

Considering the elevated prevalence of depression and anxiety in the AUD population, it is likely that some element of premorbid risk is operating at the level of brain structure. Systematic attempts to evaluate vulnerability to mood or anxiety disorders as a moderator of structural differences found in AUD have not been made. As a result, the degree to which brain differences in AUD coincide with a more general risk factor for psychopathology has yet to be addressed in the prevalent research paradigm.

Smoking status. Nicotine dependence is a potential confound receiving growing attention in MRI studies of AUD. The rate of nicotine dependence in alcohol-dependent individuals at 45.5% dwarfs that of the general population at 12.8% (Grant, Hasin, Chou, Stinson, & Dawson, 2004). Even though the majority of individuals in AUD samples are

smokers, nonsmokers make up the bulk of control groups in extant studies. The deleterious effects of smoking on the brain in general and on white matter specifically are well-documented (Swan & Lessov-Schlaggar, 2007). Accounting for independent effects of smoking or interactions of smoking with excessive drinking may be critical. Comorbid nicotine dependence has been shown to significantly exacerbate abnormalities in metabolite concentration and cerebral perfusion in alcohol-dependent individuals at 1 week of abstinence (Durazzo, Gazdzinski, Banys, & Meyerhoff, 2004; Gazdzinski et al., 2006). In non-treatment-seeking heavy drinkers, smokers showed deficits in cognition and GM volumes, whereas nonsmoking heavy drinkers did not differ significantly from nonsmoking, light-drinking controls (Durazzo, Cardenas, Studholme, Weiner, & Meyerhoff, 2007).

Treatment-seeking status. A mere 15% of individuals with AUD ever receive treatment of any kind (Hasin, et al., 2007), and evidence indicates that this subset differs substantially from the AUD population as a whole on a number of relevant demographic, physiological, and psychological variables. First, the gender distribution and comorbid psychopathology of treatment-seeking individuals may not be representative of the entire population of individuals with AUD. Epidemiological data shows that factors associated with treatment-seeking include older age, male sex, and greater lifetime incidence of mood, personality, and other substance use disorders (E. Cohen, Feinn, Arias, & Kranzler, 2007). The potential for interaction of AUD with these other disorders remains unknown.

Second, severity of alcohol dependence has been shown to differ across treatment-seeking and treatment-naïve populations. Fein and Landman (2005) compared alcohol use trajectories in treatment-naïve individuals and abstinent, treated individuals

matched on age of onset of alcohol dependence. Although groups did not differ in the time from initiation of drinking to onset of heavy drinking, the treated group had significantly higher average dose and peak dose than the treatment-naive group (Fein & Landman, 2005). Relative to the untreated group, the treated group reported alcohol consumption averaging 56% higher for males and 68% higher for females (Fein & Landman, 2005). Because greater severity of alcohol use has been linked with comorbid psychopathology and dependence on other drugs, and that study excluded individuals meeting criteria for Axis I disorders other than alcohol dependence, it may actually underestimate the degree to which drinking trajectories diverge in treatment-seeking and treatment-naive alcohol-dependent populations. In an epidemiological analysis controlling for age, gender, race/ethnicity, frequency of past year alcohol use, and age of alcohol use initiation, drinkers who had received treatment in the past year were significantly more likely to endorse 6 of 7 diagnostic criteria for alcohol dependence than were current drinkers who endorsed at least 1 of these problems but did not report past-year treatment (Lloyd, Chen, Storr, & Anthony, 2004).

A direct comparison of treatment-seeking and treatment-naïve individuals with AUD by Gazdzinski and colleagues (2008) found that these subsets differed on multiple alcohol-related variables, including lifetime consumption, family history density, and average drinks per month. Compared to the treatment-naïve group, the treatment-seeking group had significantly higher cerebrospinal fluid volume, smaller GM volumes in all cortical lobes and thalamus, and lower concentrations of metabolites reflecting neuronal viability in white matter regions, despite the absence of white matter volume differences (Gazdzinski, Durazzo, Weiner, & Meyerhoff, 2008b). Although average number of

drinks over the past year accounted for differences in white matter metabolite concentration, the majority of group differences were not accounted for by demographic factors, drinking severity, comorbid psychopathology, or other clinical variables. The treatment-naïve group manifested some brain abnormalities yet resembled the healthy comparison group more closely than the treatment-seeking group on neuroimaging measures (Gazdzinski, et al., 2008b).

Effect sizes for treatment-seeking and non-treatment-seeking samples differed significantly in the meta-analysis, with an effect size of .414 for treatment-seeking samples, in contrast to an effect size approaching zero for non-treatment-seeking samples (M. A. Monnig, Tonigan, et al., 2012). In short, convenience samples drawn from treatment-seeking populations may overestimate the magnitude of brain abnormality in individuals with AUD in the general population.

Age. Because white matter volume changes dynamically across the lifespan, age of participants may be an important factor when studying effects of alcohol on the brain. A study of brain volumes across the adult lifespan (ages 20-86) revealed that GM decreases linearly with age, whereas white matter changes in a quadratic pattern, increasing until the age of 40 and then decreasing at an accelerated rate (Ge et al., 2002). A similar study replicated the quadratic relationship between age and white matter, with volumes peaking around age 40 (Walhovd et al., 2005). A DTI study of adults aged 30-80 found a significant, negative correlation between global white matter integrity and age (Hsu et al., 2008). However, another DTI study with a slightly younger age range (21-69) found evidence for decrease in white matter integrity with age only in the genu, with no association in several other regions of interest (Abe et al., 2002).

Studies indicate that the population of those treated for alcohol dependence tends to be older than the treatment-naïve, alcohol-dependent population (E. Cohen, et al., 2007). Indeed, the treatment-seeking samples from which neuroimaging studies are drawn tend to be middle-aged, with averages ranging from mid-30's to late 50's. Not only is age confounded with duration of problematic drinking, but age and alcohol dependence may exert a synergistic effect on white matter, potentially making it difficult to isolate the effects of alcohol (Pfefferbaum, et al., 2006; E. V. Sullivan, 2000). Complicating matters further, the peak of white matter volume at approximately age 40 may obscure the linkage between age and white matter volume, given that the natural maximization of white matter volume with age may coincide with the occurrence of predicted alcohol-related decline. The fact that age was not a significant moderator in the meta-analysis (M. A. Monnig, Tonigan, et al., 2012) may be attributable to these oppositional influences.

Heavy drinking patterns and associated psychological characteristics such as impulsivity and disinhibition are typically established by young adulthood (Bennett, McCrady, Johnson, & Pandina, 1999), with studies on alcohol use typologies in young adulthood indicating that drinking patterns are largely established by age 28 (Bennett, et al., 1999). Similarly, epidemiological samples place the average age of onset of alcohol abuse or dependence at 22 (Hasin, et al., 2007). Although a small percentage of young adults (approximately 10%) experience only time-limited problem drinking, alcohol consumption and consequences remain stable for the majority of young adults (Bennett, et al., 1999). Clearly, age and duration of dependence are difficult to disentangle and

merit further consideration as potential moderators of the effect of alcohol on white matter.

Influence of white matter integrity on cognitive and functional outcomes

The possibility of white matter recovery with sustained abstinence raises the important question of how white matter integrity may influence functional outcomes. Recently, studies tying white matter microstructure to function have proliferated in the literature on cognition in normal aging. Numerous investigations have substantiated hypothesized relationships between specific cognitive domains and regional white matter microstructure. For example, investigations have found positive associations between frontal white matter and executive function, temporal white matter and memory, and parietal white matter and visuospatial ability (Engvig et al., 2010; Kantarci et al., 2011; Kennedy & Raz, 2009; Madden et al., 2009; van Norden et al., 2011; Ystad et al., 2011; Ziegler et al., 2010). In a controlled trial of an eight-week memory training program for older adults, Engvig and colleagues (2010) showed that increases in memory performance were significantly correlated with increased FA in left frontal white matter, although statistical methods to test formal mediation of memory improvement by FA unfortunately were not used.

Overall, the importance of white matter integrity to processing speed may be the strongest finding in the literature on white matter and cognition. Global white matter integrity significantly mediated cognitive processing speed beyond the variance accounted for by age in 287 healthy individuals ages 25-80 (Salami, Eriksson, Nilsson, & Nyberg, 2012). In 120 healthy adults ages 18-83, processing speed was strongly related to white matter integrity in widespread regions (Bendlin et al., 2010). Another study found

that white matter integrity accounted for 10% of the variance in general intelligence in healthy, older adults and that this relationship was fully mediated by processing speed (Penke et al., 2012).

Research linking white matter integrity to treatment outcomes in the field of AUD is scarce at present. Sorg et al. (2012) obtained DTI on 45 individuals with AUD at the initiation of treatment and compared baseline DTI measures between participants who had resumed heavy drinking at 6-month follow-up versus those who had maintained treatment gains. The group that returned to heavy drinking showed lower baseline FA in bilateral frontal lobes, including parts of the corpus callosum, uncinate fasciculus, corona radiata, and internal capsule. Interestingly, lifetime number of drinks, years of AUD, past 30-days drinking history, and past-year drinking history did not correlate with DTI measures (Sorg et al., 2012).

Chung et al. (2012) found that prefrontal white matter integrity at the beginning of treatment was a significant mediator of the direct path from motivation to abstain from alcohol at baseline to AUD severity at 6-month follow-up. However, lower white matter integrity was related to greater motivation to abstain, contrary to the authors' predictions. The authors suggested that lower white matter integrity might have been related to greater motivation because participants were to some extent aware of their difficulty regulating their drinking (Chung, Pajtek, & Clark, 2012). In bivariate correlations, higher white matter integrity at baseline was related to lower 6-month AUD severity, similar to the findings of Sorg et al. (2012).

Another study tested over 30 cognitive, neurophysiological, and psychiatric measures as predictors of relapse at 6-12 months in a naturalistic study of 70 AUD

individuals (Durazzo, Gazdzinski, Yeh, & Meyerhoff, 2008). Processing speed and levels of a brain metabolite related to neuronal integrity (*N*-acetylaspartate, NAA) in frontal white matter were two of only five significant predictors. Although this study did not directly test DTI measures as predictors of relapse, the strong relationship between processing speed and white matter integrity evinced in the cognitive aging literature suggests that white matter integrity is a plausible predictor of AUD outcomes.

Method

From this review of research into white matter networks in AUD, it is clear that alcohol-related white matter abnormality is widespread, yet many questions remain about its correlates and causes. DTI studies in AUD individuals have yielded useful leads as to the likely networks involved. However, these studies have been small, lacking power to test mediators and moderators of alcohol-related white matter abnormality. Moreover, these studies largely have utilized treatment-seeking convenience samples, limiting the generalizability of findings to the entire AUD population. Finally, information on functional correlates of white matter integrity is lacking. The present study sought to systematically evaluate associations between white matter integrity and clinical characteristics. Ultimately, establishing efficient markers of lower white matter integrity could facilitate treatment and recovery of function in AUD individuals by alerting clinicians to the need for increased level of assessment or support.

This study investigated mediators and moderators of the relation between chronic alcohol consumption and white matter integrity in a cross-sectional dataset of neuroimaging and behavioral data collected from 324 heavy drinkers. The sample demonstrated diversity in demographic characteristics, drinking behavior, and problem severity. Analyses utilized a statistical framework designed to integrate data across behavioral and neurobiological levels of analysis.

Participants

Participants were between the ages of 21 and 56, had no contraindications for MRI scanning (e.g., pregnancy, pacemaker), and reported no history of brain injury or loss of consciousness > 5 minutes. Participants were instructed to abstain from alcohol

for 24 hours prior to study procedures, and a blood alcohol concentration of zero was confirmed with a Breathalyzer prior to scanning. Participants were excluded if they were in need of medical detoxification, as determined by a score greater than 8 on the Clinical Institute Withdrawal Assessment of Alcohol Scale, Revised (J. T. Sullivan, Sykora, Schneiderman, Naranjo, & Sellers, 1989). Treatment-naïve participants reported no history of treatment for substance abuse and at least 5 binge drinking episodes (≥ 4 drinks for women, ≥ 5 drinks for men on a single occasion) in the past month. Treatment-seeking participants reported > 14 drinks per week for women and > 21 drinks for men during 4 consecutive weeks during the past 3 months. At the assessment session, participants completed questionnaires and a neuroimaging session lasting approximately 2 hours and were compensated \$120 for their time and effort. All study procedures were approved by the Human Research Review Committee at the University of New Mexico, and study participants provided informed consent.

Diagnostic testing

Participants completed the Alcohol Use Disorders Identification Test [AUDIT (Babor, Higgins-Biddle, Saunders, & Monteiro, 2001)], the Alcohol Dependence Scale [ADS (Skinner & Horn, 1984)] and the Impaired Control Scale [ICS (Heather, Tebbutt, Mattick, & Zamir, 1993)] in addition to demographic and drinking history questionnaires. To obtain number of years drinking (NYD), the age at which the participant reported starting to drink regularly was subtracted from his or her current age.

Recent use of alcohol and tobacco was assessed using the Timeline Followback [TLFB (Sobell & Sobell, 1992)]. Drinks per drinking day (DPDD), percentage of days

drinking (PDD), percentage heavy drinking days (PHDD), and number of days since last drink were chosen as measures of quantity, frequency, and recency.

Clinical symptoms of depression and anxiety were assessed with the Beck Depression Inventory-II [BDI (Beck, Steer, & Brown, 1996)] and Beck Anxiety Inventory [BAI (Beck & Steer, 1993)], respectively. Clinical cutoff scores on these instruments were used to categorize participants as positive or negative for significant symptoms of depression or anxiety.

The two-subtest form of the Wechsler Abbreviated Scale of Intelligence [WASI (Psychological Corporation, 1999)] was administered to a subset of participants to assess cognitive functioning. Analyses used raw scores for Vocabulary and Matrix Reasoning tests, with and without age as a covariate.

Medical lab testing

Participants underwent standard blood draw procedures and had measurements taken of height, weight, and waist circumference. Body mass index (BMI) was calculated using the standard formula. Blood tests included bilirubin, alkaline phosphatase (ALP), aspartate aminotransferase (AST), alanine aminotransferase (ALT), gamma-glutamyl transpeptidase (GGT), lactate dehydrogenase (LDH), mean corpuscular volume (MCV), triglycerides, and cholesterol. Elevation in liver enzymes is a biomarker of heavy drinking, but the sensitivity and specificity of these tests vary (Allen & Litten, 2001). Elevations can be the result of tissue damage or other conditions unrelated to drinking. Some studies have linked elevations in liver enzymes to brain atrophy in heavy drinkers (Chen et al., 2012; de Bruin, Lemmens, Hulshoff Pol, Verbaten, & Kenemans, 2012). Increased risk of metabolic syndrome (obesity, abdominal adiposity, triglycerides) also

has been linked to consuming more than 1-2 drinks per day and binge drinking (Fan et al., 2008).

DTI protocol

Image acquisition. All MRI scans were collected on a 3T Siemens Trio (Erlangen, Germany) whole body scanner. Prior to the acquisition of anatomical scans, localizer scans were acquired. An echo-planar gradient-echo pulse sequence (TR = 2000 ms, TE = 29, flip angle = 75°) was acquired with an 8-channel head coil, and images were acquired parallel to the ventral surface of the participant's orbitofrontal cortex to reduce signal dropout and distortion in this region (Deichmann, Gottfried, Hutton, & Turner, 2003). Each volume consisted of 33 axial slices (64 x 64 matrix, 3.75 x 3.75 mm², 3.5 mm thickness, 1 mm gap). In addition, a high resolution T1-weighted MP-RAGE anatomical image was acquired (TR = 2530 ms, TE = 1.64 ms, flip angle = 7°, 192 sagittal slices, 256 x 256 matrix, slice thickness = 1 mm, no gap) for each participant.

DTI scans were acquired via a single-shot spin-echo planar imaging with a twice-refocused balanced echo sequence to reduce eddy current distortions. DTI data were collected along the AC/PC line, with FOV = 256 x 256 mm, 128 x 128 matrix, slice thickness of 2 mm (isotropic 2 mm resolution), NEX = 1, TE = 84 ms and TR = 9000 ms. A multiple-channel radiofrequency (RF) coil was used, with GRAPPA (X2), 30 gradient directions, $b = 800 \text{ s/mm}^2$, and the $b = 0$ experiment repeated 5 times (Jones, Horsfield, & Simmons, 1999).

DTI analysis. DTI preprocessing entailed data quality check, motion eddy current correction, and adjustment of diffusion gradient directions. 1) Data quality check. The DTI data was checked for a) signal dropout due to subject motion, producing striated

artifacts on images; b) excessive background noise in the phase encoding direction, due to external RF leakage in the MRI scan room or subject motion; and c) large amounts of motion in the absence of signal dropout. A DTI volume was excluded if the motion was more than 4mm of root mean square displacement. If more than 10% of gradient directions were dropped for any of the above reasons, then the subject was excluded from further analysis. Of 481 participants scanned, data for 145 were excluded by stringent quality control, leaving 336 participants with acceptable DTI data.

2) Motion and eddy current correction. All images were registered to a $b = 0$ s/mm² image. A twelve-degrees-of-freedom, affine transformation with mutual information cost function was used for image registration.

3) Adjustment of diffusion gradient direction. Two corrections were applied to the diffusion gradients. The nominal diffusion gradient directions were prescribed in the magnet axis frame. They were rotated to correspond to the image slice orientation. No correction was required if the imaging slice was pure axial. A second correction accounted for any image rotation during the previous motion and eddy current correction step. The rotation part of the transformation found previously was extracted, and each gradient direction vector was corrected accordingly. All the image registration and transformations were done with FLIRT, and the detection of outliers and data pruning was done with a custom program written in IDL (www.itvis.com). Dtifit was used to calculate the diffusion tensor and the FA maps. The FA image was aligned to an MNI template with a nonlinear registration algorithm (FMRIB's Nonlinear Image Registration Tool) and resliced via SPM resulting in a final voxel size of 1×1×1 mm. The tract-based spatial statistics tool (S. M. Smith et al., 2006) in the FMRIB Software Library toolbox was used to calculate FA values for the white matter skeleton at a

threshold of .20. FA values for regions of interest (ROIs) were obtained by overlaying a white matter atlas on the white matter skeleton (Mori, Wakana, Nagae-Poetscher, & van Zijl, 2005; Wakana et al., 2007) and calculating an average FA value for the voxels within the ROI for each subject.

Selection of DTI variables

White matter ROIs were chosen on the basis of their association with functional response to an alcohol taste cue in a previous study with the same sample of heavy drinkers (M.A. Monnig et al., under review). The study examined correlations of white matter FA values for 18 white matter ROIs chosen a priori with fMRI blood-oxygenation-level-dependent (BOLD) response to an alcohol taste cue. Of the 18 white matter ROIs, two midline (fornix, body of corpus callosum) and three bilateral (cingulate gyrus, external capsule, superior longitudinal fasciculus) ROIs were significantly, negatively correlated with BOLD activity when applying a GM mask, thresholding results at $z = 2.3$, and using age as a covariate. In brief, lower white matter integrity in these ROIs was associated with greater response to the alcohol cue in widespread brain regions. All of these ROIs have shown lower white matter integrity in AUD individuals compared to healthy individuals in previous DTI studies (Harris, et al., 2008; M. A. Monnig, Caprihan, et al., 2012; Pfefferbaum, et al., 2009; Yeh, et al., 2009). Although study design did not allow for testing causal mechanisms, results suggest that these ROIs play a role in alcohol cue reactivity. A possible mechanism may be that lower white matter integrity in these areas, whether premorbid or accrued through excessive drinking, compromises neural networks that regulate response to alcohol, resulting in greater sensitivity to alcohol cues.

The white matter ROIs implicated in the fMRI-DTI study are diverse in anatomical location and function. Figure 1 shows individual ROIs, and Figure 2 presents the ROIs simultaneously to give an idea of their relative positioning. The body of the corpus callosum constitutes the middle segment of the commissural tract connecting left and right hemispheres. Fibers connecting contralateral premotor and supplementary motor cortices, primary motor cortices, and posterior parietal cortices traverse the body of the corpus callosum (Hofer & Frahm, 2006). The fornix is a subcortical limbic structure forming the primary output pathway of the hippocampus and projecting to the mammillary bodies. This pathway is part of a limbic circuit that continues on to the anterior thalamic nucleus, then to the cingulum, which in turn carries input back to the hippocampus. Not surprisingly, both the fornix and the cingulum are strongly involved in memory and emotion. White matter integrity of the fornix has been shown to relate to memory function in normal aging and Alzheimer's disease (Sasson, Doniger, Pasternak, Tarrasch, & Assaf, 2013; Zhuang et al., 2012). The cingulum plays a role in complex behavioral functions including decision-making, evaluation of reward, and performance monitoring (M. X. Cohen, Heller, & Ranganath, 2005; Holroyd & Yeung, 2012; Rogers et al., 2004). The superior longitudinal fasciculus is a corticocortical association fiber that facilitates intrahemispheric communication. It is a laterally-situated frontoparietotemporal fiber that serves numerous functions, including visuospatial and language processing, higher-order sensorimotor integration, and regulation of attention (Fernández-Miranda et al., 2008; Schmahmann, Smith, Eichler, & Filley, 2008). The external capsule is a projection tract connecting cortex with the claustrum, which is a subcortical GM structure situated between the insula and putamen (Fernández-Miranda,

Rhoton, Kakizawa, Choi, & Alvarez-Linera, 2008). Although current evidence is limited, the claustrum is thought to be involved in integration of input across sensory modalities.

Instead of averaging across hemispheres or networks, the FA values for the individual tracts [body of corpus callosum, fornix (midline column portion), right and left cingulate gyrus, right and left external capsule, right and left superior longitudinal fasciculus] were entered as indicators of a common white matter integrity factor (WMIF), as described below. This method reduced the DTI data to a single factor score reflecting white matter integrity for each participant while maintaining the unique contributions of the original values.

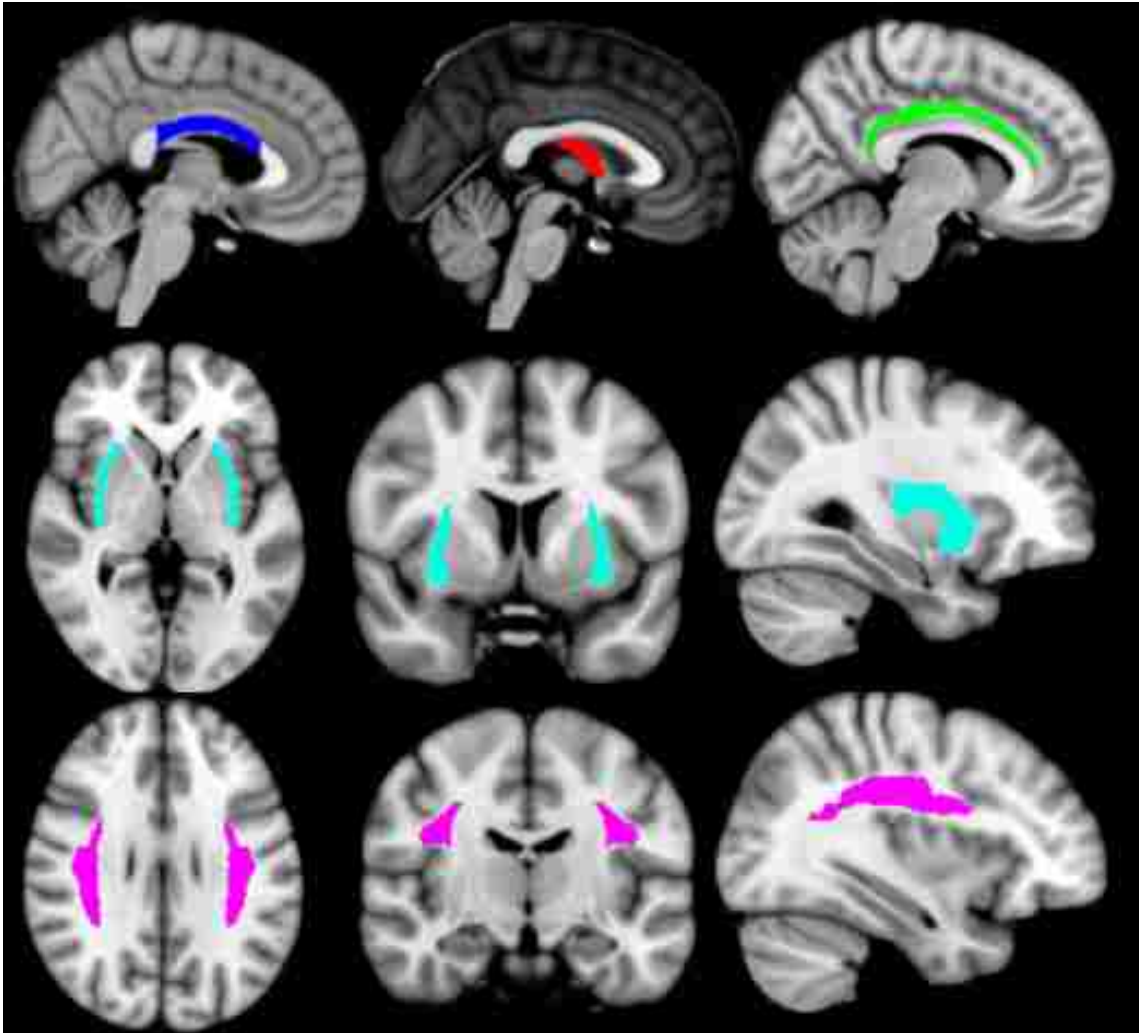
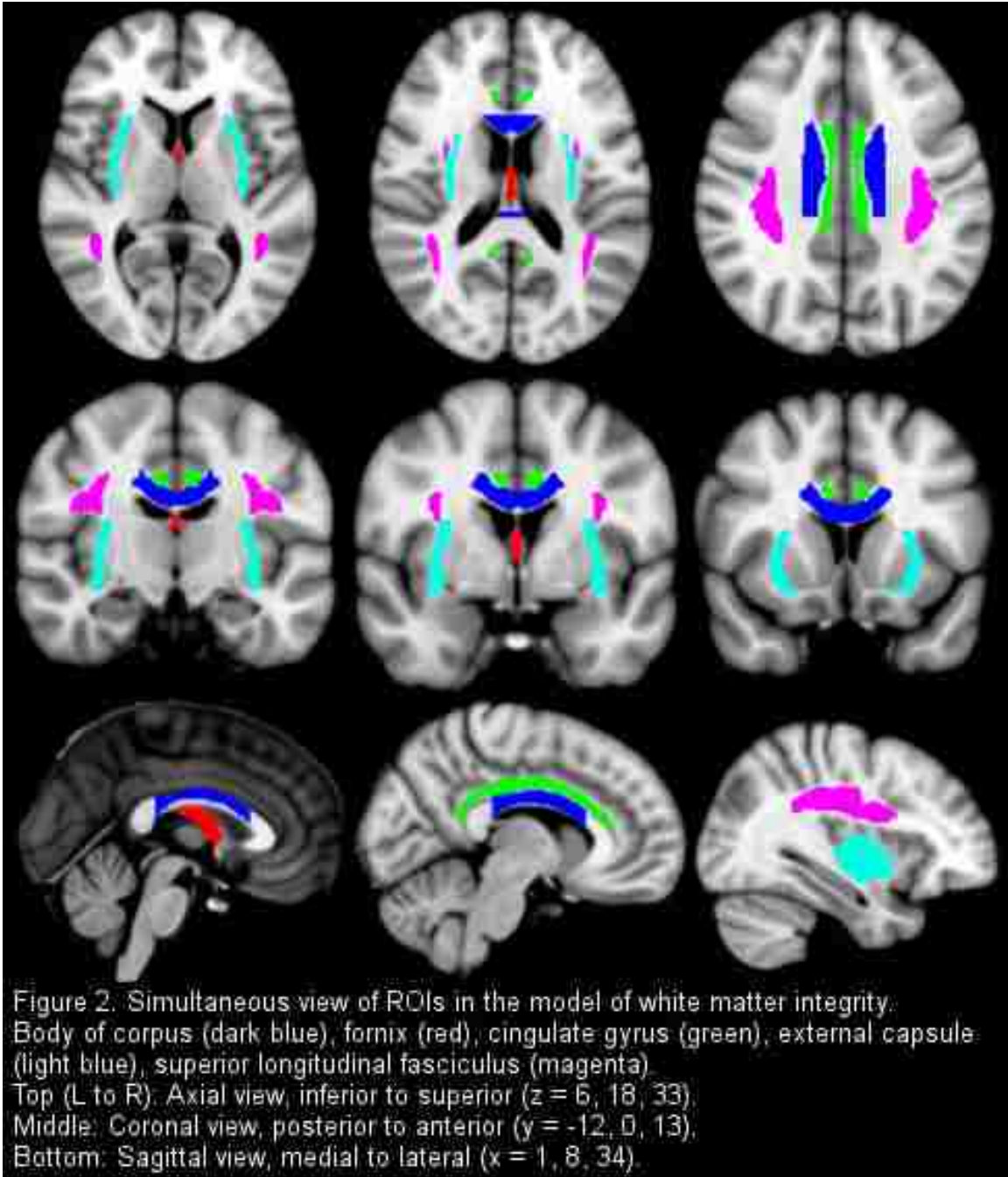

Figure 1. ROIs included in model of white matter integrity.
Top (L to R): Body of corpus callosum (dark blue); fornix (red); cingulate gyrus (green).
Middle: Axial, coronal, and sagittal views of external capsule (light blue).
Bottom: Axial, coronal, and sagittal views of superior longitudinal fasciculus (magenta).



Statistical analysis

Statistical analyses were organized by the study's three major aims. In pursuing these aims, latent variable modeling was applied to the construct of white matter integrity and to other psychological or biological constructs of interest where appropriate. White matter integrity was represented by a latent variable because this approach has the

advantage of isolating the variance common to observed variables at the same time that it avoids the pitfall of treating observed variables as free of error (MacCallum & Austin, 2000). Conceptually, latent variable modeling treats white matter integrity as a construct represented by what is common among tracts that have been implicated in AUD. As such, it has the strength of examining patterns of relationships with the construct, as opposed to a conglomeration of observed variables. A corollary advantage is reducing the number of tests, as the common factor reduces DTI metrics of eight ROIs to a single variable.

1. The first aim identified markers of alcohol-related white matter variation by testing mediators of the path from number of years drinking (NYD) to the latent WMIF. Variables of interest were participants' scores on AUD questionnaires, recent drinking history, and laboratory tests of liver and metabolic health. Next, the relative significance of mediators controlling for effects of other variables was evaluated in multiple mediation models. The objective was to determine which variable or variables best predicted white matter integrity, either individually or in combination.
2. The second aim investigated gender, treatment-seeking status, smoking status, and comorbidity as potential moderators of the relation between duration of drinking and WMIF. Moderated mediation models tested whether AUD mediators functioned comparably across subpopulations.
3. The third aim examined functional implications of white matter integrity in AUD by relating WMIF to cognitive performance. After testing

direct relations between WMIF and cognitive domains, WMIF was tested as a mediator of the path from NYD to cognitive functioning.

Data transformations. Non-normality of variables was addressed by excluding outliers or transforming data. On the white matter ROIs included as factor indicators, 12 of the total 336 participants had FA values that were outliers of > 3 standard deviations (*SDs*) on at least one ROI. Outliers typically had very low FA scores. They were significantly older and had greater NYD than non-outliers. However, they did not differ significantly on ADS, AUDIT, ICS, PDD, DPDD, PHDD, education, or gender composition. Outliers were excluded from all analyses, leaving 324 participants with DTI data. Number of days since last drink was a highly skewed variable, with 96% of participants reporting values ranging from 0-5 days. Because of the small number of outliers and the inability of commonly used transformations to normalize the data, the 10 outliers of > 3 *SDs* were excluded from analyses with the last drink variable.

DPDD, ALP, AST, ALT, and triglycerides had distributions with positive skew. Square-root transformations brought skewness and kurtosis values to acceptable levels. Analyses using DPDD, ALP, AST, ALT, or triglycerides as observed predictor variables used the square-root transformed values. When these variables were used as factor indicators, however, raw values were used with an estimation method robust to non-normality.

FA values were multiplied by 100 to prevent very small standard errors from causing estimation problems in the models.

Confirmatory factor analysis (CFA). Measurement models were attempted for factors representing five constructs: WMIF, AUD Severity (endorsed in psychological

self-report questionnaires), Drinking Behavior (reported on the TLFB), Liver Health (reflected in laboratory tests), and Metabolic Health (represented by risk factors for metabolic syndrome). Variables were not used as indicators of more than one factor.

Analyses were conducted on the variance-covariance matrix in Mplus version 7 (L. K. Muthen & Muthen, 1998-2012). Maximum likelihood (ML) estimation was used for factor analysis except where factor indicators were non-normal, in which case maximum likelihood estimation with robust standard errors (MLR) was used. ML and MLR allow for missing data under the assumption that data were missing at random. ML procedures allow for use of all available data without discarding cases with missing values or imputing values, and it has been shown to produce less biased parameter estimates than casewise deletion or single imputation methods for handling missing data (Baraldi & Enders, 2010). Each latent variable was scaled by setting its variance to 1.0. All measurement error was presumed to be uncorrelated except where noted below.

For individual parameter estimates, the significance value was set to $p < .05$. For evaluation of model fit, standardized root mean square residual (SRMR), root-mean-square error of approximation (RMSEA), and comparative fit index (CFI) are reported as absolute, parsimony-corrected, and comparative goodness-of-fit indices, respectively (Jackson, Gillaspay, & Purc-Stephenson, 2009). As cutoff criteria, $SRMR < .08$, $RMSEA < .06$, and $CFI > .95$ were interpreted as indicating good model fit. Adopting more lenient standards, $RMSEA < .10$ and $CFI > .90$ were interpreted as showing marginally acceptable model fit.

Because treatment-seeking and treatment-naïve groups differed significantly on a number of demographic variables as well as problem severity measures, differences in

WMIF across groups were evaluated. Following recommendations in the literature (Brown, 2006; L. K. Muthen & Muthen, 1998-2012), the extent of measurement invariance was assessed in the following steps: 1) the factor model was fit in each group separately; 2) both groups were included in a single model, but all parameters were estimated separately for each group; 3) factor loadings were constrained to be the same for both groups (i.e., weak invariance); 4) indicator intercepts (i.e., the means of indicators, or the predicted value of the indicator when the latent factor is zero) were constrained to be the same for both groups (i.e., strong invariance). Comparison of these progressively more restrictive models used the χ^2 difference statistic, with $p < .05$ representing a significant decrement in fit for the model with more constraints compared to the model with fewer constraints.

Structural equation modeling (SEM). Figure 3 shows a basic mediation model for reference purposes. In all diagrams, circles indicate latent variables, and squares represent observed variables. Analyses were conducted on the variance-covariance matrix using ML estimation in Mplus version 7. Standard errors of model parameter estimates, including indirect effects, and their confidence intervals (CIs) were estimated with the bootstrap option in Mplus with 500 iterations for ML analyses (Enders & Tibshirani, 1993). Asymmetric CIs can result from bootstrapping, as this method accounts for non-normality of the parameter estimate (MacKinnon, 2008; L. K. Muthen & Muthen, 1998-2012). It is not unusual for the product of coefficients (i.e., the a and b paths of the indirect effect) to have a non-normal distribution. In such cases, bootstrapped CIs may be a more accurate test of significance than the traditional p -value (MacKinnon, 2008; L. K. Muthen & Muthen, November, 2011). In Monte Carlo studies, the bias-corrected

bootstrap with asymmetric CIs has shown superior power to detect a mediation effect over all other methods (Fritz & Mackinnon, 2007; MacKinnon, 2008). Therefore, both p -values and CIs are reported for indirect effects where relevant.

Figure 3. Simple mediation model, from (Rucker, Preacher, Tormala, & Petty, 2011). Top row: the total effect (c) of the independent variable X on the dependent variable Y . The arrow indicates error variance, i.e., variance not accounted for by the relationship between X and Y . Bottom row: the indirect effect of the independent variable X on the dependent variable Y through mediating variable M . Path c' represents the direct effect of X on Y after controlling for the mediator. The a path represents the effect of X on M . The b path represents the effect of M on Y , controlling for X . The product of a and b equals the indirect effect.

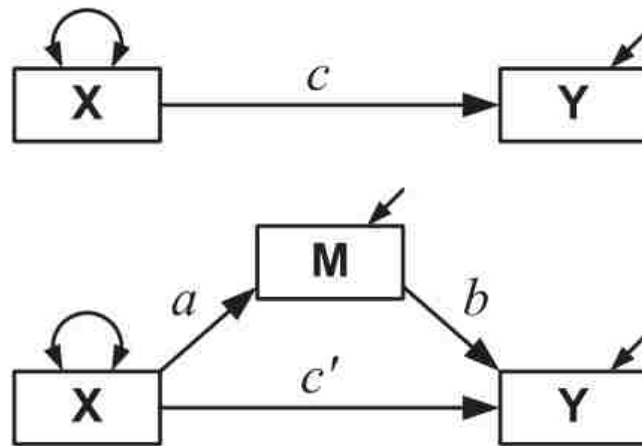

Simple and multiple mediation. These analyses tested simple and multiple mediation of the path from NYD to WMIF. The objective was to identify which variables, alone or in combination, were most closely associated with white matter integrity, controlling for chronicity of drinking. Simple mediation models tested mediation of the path from NYD to WMIF by the following observed variables: ADS, AUDIT, ICS, PDD, DPDD, PHDD, last drink, bilirubin, ALP, AST, ALT, GGT, LDH, MCV, BMI, waist circumference, triglycerides, and total cholesterol. Multiple mediation analyses tested simultaneous mediation of the path from NYD to WMIF by all of the observed variables within a single category (psychological, behavioral, or physiological). Significant

mediators from each category then were tested in a multiple mediator analysis, and a contrast tested whether indirect effects for mediators differed from each other (K. J. Preacher & Hayes, 2008).

Mediation by latent variables. A further possibility was that the latent variables created in the CFA might mediate the path from NYD to WMIF. Following CFA, latent variables with good model fit were tested as mediators. Testing these latent variables in addition to the observed variables in the previous step allowed for assessment of mediation by constructs of AUD Severity, Drinking Behavior, Liver Health, or Metabolic Health, where these constructs were successfully fit to a measurement model. Using the latent variable instead of observed variables can increase power by eliminating measurement error from the construct of interest.

Moderated mediation. Previous research has pointed to treatment-seeking status, gender, smoking status, and comorbidity as potential moderators of the relationships of interest. Moderated mediation models (K. Preacher, Rucker, & Hayes, 2007) assessed whether mediation effects differed depending on these between-group factors. Essentially, moderated mediation models tested whether between-group characteristics showed an interaction with effects in simple mediation models. Participants were coded as smokers if they reported any smoking on the TLFB. Smokers reported an average of 8.5 ± 7.5 cigarettes per smoking day. A dichotomous comorbidity variable (0 = low, 1 = high) was created to indicate the presence of greater than minimal symptoms of anxiety or depression according to clinical cutoffs on the BAI and BDI, respectively. Participants with BAI score > 15 or BDI score > 13 were coded as high comorbidity. Using a single dichotomous variable to represent comorbidity allowed for maximum sample size, as

many participants had data for only one test. Moreover, the interest in comorbidity pertained more to the general presence of commonly comorbid disorders rather than to specific psychopathology. For the 202 participants with scores for both inventories, the BDI and BAI were moderately correlated ($r = .470, p < .001$).

As a preliminary to SEM, the 8 white matter ROIs (i.e., 2 midline and 3 bilateral) were entered as within-subjects measures in repeated measures ANOVA in SPSS version 20 to test for main effects of group status and to test whether NYD was a significant covariate. A separate test was conducted for each group designation (treatment-seeking status, gender, smoking status, comorbidity) for a total of four ANOVAs.

To reduce the number of tests, moderated mediation models focused on observed and latent mediators that performed well in single-group analyses. Moderation of the a path and b path was tested by freeing these parameters one at a time while constraining all other paths in the model to be equal across groups. Factor loadings and intercepts were constrained to be equal for each group, whereas residual variances were allowed to vary. The χ^2 difference test evaluated difference in fit between the parent model with all paths constrained to be equal for the groups to the nested model with the freed parameter (i.e., a path or b path). A χ^2 value corresponding to a significance value of $p < .05$ indicated that allowing the parameter estimate to vary across groups resulted in significantly better model fit, giving evidence of significant moderation.

WMIF and cognitive performance. To examine the association between WMIF and cognitive performance, WMIF first was tested as a predictor of WASI Vocabulary and Matrix Reasoning scores in a regression framework. In the 137 participants (31 treatment-naïve, 106 treatment-seeking) with cognitive test scores, Vocabulary and

Matrix Reasoning were modestly correlated ($r = .231, p = .005$). Note that sample size was not reduced by missing data because ML estimation was used. ML directly estimates parameters using all available data and without imputing values for participants with missing data. Parameter estimates were derived from 137 participants with observed scores for all variables and the remaining 166 participants without cognitive scores but with data for remaining variables in the model. Consequently, minimum covariance coverage for variables in the model was .452, which was statistically feasible but may have introduced some bias in that patterns in missing data may not have been accounted for fully by the available observed scores.

Previous research has shown that visuospatial ability is the neuropsychological domain most consistently affected in AUD, whereas crystallized verbal functions involved in vocabulary retrieval tend to be spared (Fein, Bachman, Fisher, & Davenport, 1990; Fein, Torres, Price, & Di Sclafani, 2006; Lezak, Howieson, & Loring, 2004; J. A. Molina et al., 1994). Moreover, treatment-naïve samples have not shown significant decrements in cognition relative to healthy individuals, unlike most treatment-seeking samples (S. Smith & Fein, 2010). Therefore, deficits were expected to manifest in performance on the visuospatial subtest, but not on verbal subtest, and to a greater degree in treatment-seeking individuals. Specifically, it was hypothesized that 1) WMIF would be significantly, positively related to Matrix Reasoning but not Vocabulary; 2) NYD would be significantly, negatively related to Matrix Reasoning but not Vocabulary; 3) WMIF would mediate the path from NYD to Matrix Reasoning; and 4) treatment-seeking status would moderate such that the indirect path from WMIF to Matrix Reasoning would be of greater magnitude in the treatment-seeking group.

Because age is associated with decline in visuospatial performance and white matter integrity (Hsu et al., 2008; Lezak, et al., 2004), it was plausible that age, not chronic alcohol exposure, was driving the associations among NYD, WMIF, and Matrix Reasoning. Two supplementary models were created to test this possibility. The first model controlled for the effect of age on both WMIF and Matrix Reasoning. The second model controlled for the effect of age only on Matrix Reasoning.

Exploratory analyses. Finally, construction of WMIF according to associations between its constituent ROIs and functional response to an alcohol taste cue prompted an additional hypothesis. It was hypothesized that perceived loss of control over drinking (ICS score) would mediate the direct path from lower white matter integrity to increased DPDD. The section on exploratory analyses addresses this model as well as alternative models of relationships among these variables.

Statistical power. As noted, the bias-corrected bootstrap has demonstrated the greatest power to detect a mediation effect in simulation studies (Fritz & Mackinnon, 2007). Data were available for 324 participants for WMIF and 303 participants for NYD. Analyses using NYD as the independent predictor were limited to 303 participants. On the conservative assumption that the true effect size in the population for the mediated effect is small, a sample of 462 would be needed to have power of .8 (Fritz & Mackinnon, 2007). Assuming a slightly larger effect size, a sample size of 148 would be needed (Fritz & Mackinnon, 2007). Therefore, the sample sizes available for most of the analyses in this study were adequate for a modest mediated effect but inadequate for a small effect. For analyses of liver and health variables, data were available for only 50 participants. This sample size would be inadequate unless the mediation effect in the population is

large (Fritz & Mackinnon, 2007), which is unlikely. As a result, no inferences could be made from these analyses, which are presented only for reference.

Results

Descriptive statistics

Descriptive statistics for demographic and clinical characteristics are shown in Table 2. Because most analyses used NYD as a predictor and so were limited to participants with data for NYD, Table 2 shows statistics for the 303 participants who had NYD data and were not outliers on white matter ROIs. Participants were fairly young, were predominantly male, and varied widely in NYD. They endorsed moderately high problem severity and frequently consumed alcohol at hazardous levels.

Table 2. Descriptive statistics for participants with data for WMIF and NYD ($n = 303$)

	<i>n</i>	<i>M</i>	<i>SD</i>
Age	303	30.86	9.08
Sex (% male)	303	70	—
Education	269	14.40	2.51
NYD	303	11.70	8.77
ADS score	283	13.11	8.05
AUDIT score	283	18.52	7.65
ICS score	286	44.74	21.00
DPDD	278	7.11	4.29
PDD	278	59	25
PHDD	242	44	28
Days since last drink	234	2.55	3.07
BDI score	243	11.87	9.42
BAI score	273	9.40	8.36
Bilirubin (mg/dL)	49	0.82	0.34
ALP (U/L)	49	84.94	25.93
AST (U/L)	49	38.55	20.90
ALT (U/L)	49	43.67	29.36
GGT (U/L)	49	53.90	39.04
LDH (U/L)	49	448.12	84.74
MCV (fL)	48	94.12	3.68
Body mass index	50	27.46	4.25
Waist circumference (cm)	45	92.02	11.27
Triglycerides (mg/dL)	49	140.06	89.73
Total cholesterol (mg/dL)	49	187.65	33.69
WASI Vocabulary	137	55.79	10.21
WASI Matrix Reasoning	137	25.62	5.47

Bivariate correlations between predictors are shown in Table 3. Table 4 shows participant characteristics by each moderator. As expected, treatment-seeking and treatment-naïve groups differed on all variables except gender composition and Vocabulary score. The treatment-seeking group had significantly higher age, NYD, ADS, AUDIT, ICS, DPDD, PDD, PHDD, and days since last drink; they also had lower Matrix Reasoning scores. In contrast, the only difference observed for males and females was significantly higher DPDD for males by less than two drinks. Interestingly, non-smokers and smokers were similar in actual drinking behavior, but smokers endorsed significantly greater problem severity on the ADS, AUDIT, and ICS; smokers also had lower levels of education. Relative to the group with low levels of comorbid anxiety and depression, the high comorbidity group had significantly lower education, higher scores on ADS, AUDIT, and ICS, and greater DPDD and PHDD.

Descriptive statistics for FA values of all participants with DTI data, excluding the 12 outliers, are shown in Table 5.

Table 3. Bivariate correlations for participants with NYD data ($n = 303$).

	NYD	ADS	AUDIT	ICS	PDD	DPDD	PHDD	Last drink	Bili-rubin	ALP*	AST*	ALT*	GGT	LDH	MCV	BMI	Waist	Trig*	Chol	Age
NYD	1.00																			
ADS	.267	1.00																		
AUDIT	.371	.822	1.00																	
ICS	.415	.736	.803	1.00																
PDD	.336	.211	.314	.348	1.00															
DPDD*	.309	.593	.618	.529	.127	1.00														
PHDD	.434	.379	.543	.510	.752	.489	1.00													
Last drink	.055	.206	.081	.074	-.217	.211	-.125	1.00												
Bilirubin	-.147	-.145	-.123	-.114	.242	-.028	.065	-.066	1.00											
ALP*	-.017	.031	.062	-.020	-.043	-.068	.071	-.050	.204	1.00										
AST*	.116	-.166	-.148	.010	.032	-.104	-.013	-.134	.221	.082	1.00									
ALT*	.241	-.029	-.032	.116	-.098	-.074	-.080	-.113	-.096	-.106	.794	1.00								
GGT	.022	-.095	-.115	-.049	-.076	-.112	-.114	-.056	.213	.227	.548	.596	1.00							
LDH	.062	-.146	.100	.240	.081	.087	.149	-.222	-.071	-.110	.185	.213	-.176	1.00						
MCV	.117	.047	.009	.019	.127	-.045	.073	.063	.158	-.101	.351	.264	.151	-.202	1.00					
BMI	.024	.013	.014	.068	.137	.187	.228	.094	.021	.040	.019	.014	.090	.323	-.056	1.00				
Waist	.156	-.108	-.104	-.051	.019	.259	.190	.049	.073	.099	.162	.173	.310	.314	-.129	.771	1.00			
Trig*	.119	.131	.093	.059	.028	.102	.256	.016	-.174	.380	-.202	.005	.389	-.127	-.263	.274	.376	1.00		
Chol	.283	-.168	-.153	-.215	.083	.091	.300	-.056	-.338	.240	-.012	.113	.113	.071	-.101	.181	.219	.397	1.00	
Age	.877	.255	.345	.468	.367	.269	.450	.028	-.075	.242	.224	.203	.069	.068	.173	.097	.177	.019	.448	1.00

* indicates that correlations are with the square-root transformed variable.

Gray highlighting indicates $p < .05$.

n 's for ADS, AUDIT, ICS, PDD, DPDD, PHDD, and last drink ranged from 240-299. n 's for lab and metabolic variables ranged from 39-50.

Table 4. Descriptive statistics by moderating variables.

	Treatment-seeking status																			
	Treatment-naïve (n = 189)				Treatment-seeking (n = 114)				Gender				Smoking status				Comorbidity			
	M	SD	M	SD	M	SD	M	SD	Male (n = 211)	Female (n = 92)	Non-smoker (n = 141)	Smoker (n = 161)	Low (n = 185)	High (n = 112)	M	SD	M	SD		
Age	26.35*	5.57	38.34*	8.85	30.89	9.13	30.82	9.02	30.96	9.60	30.68	8.56	30.55	9.41	31.78	8.58	66	—		
Sex (% male)	71	—	67	—	—	—	—	—	—	—	72	—	72	—	—	—	—	—		
Education	15.02*	2.64	13.54*	2.03	14.25	2.54	14.73	2.40	14.77*	2.47	14.08*	2.50	14.80*	2.19	13.76*	2.80	—	—		
NYD	8.06*	5.76	17.73*	9.56	12.10	9.05	10.77	8.05	11.23	8.90	12.00	8.59	11.23	8.92	12.83	8.52	—	—		
ADS score	10.00*	5.63	17.72*	8.88	12.71	7.76	14.07	8.69	11.75*	7.75	14.25*	8.17	10.30*	6.37	17.53*	8.46	—	—		
AUDIT score	15.09*	6.14	23.67*	6.77	18.77	7.44	17.93	8.14	17.00*	7.71	19.79*	7.42	15.97*	6.84	22.74*	7.03	—	—		
ICS score	33.56*	17.32	61.61*	13.46	44.27	20.69	45.82	21.80	41.86*	21.20	47.05*	20.54	37.93*	19.47	55.78*	18.60	—	—		
DPDD	5.87*	2.54	8.92*	5.52	7.65*	4.55	5.82*	3.32	6.77	4.88	7.41	3.72	6.27*	3.14	8.43*	5.39	—	—		
PDD	0.53*	0.22	0.69*	0.27	0.60	0.25	0.57	0.26	0.59	0.26	0.59	0.25	0.57	0.26	0.63	0.25	—	—		
PHDD	0.34*	0.20	0.58*	0.32	0.45	0.29	0.41	0.28	0.41	0.28	0.45	0.27	0.40*	0.28	0.49*	0.28	—	—		
Days since last drink	2.16*	1.42	3.13*	4.47	2.61	3.15	2.37	2.85	2.68	2.81	2.44	3.29	2.49	3.16	2.63	2.95	—	—		
Vocabulary Matrix	58.55	10.16	54.98	10.13	56.29	10.17	54.76	10.31	57.16	11.78	54.56	8.55	56.60	10.11	54.83	10.58	—	—		
Reasoning	28.32*	3.26	24.83*	5.74	25.88	5.47	25.09	5.49	25.44	5.59	25.82	5.42	25.71	5.84	25.08	4.99	—	—		

* indicates a significant difference ($p < .05$) between groups within a moderator category.

Table 5. Descriptive statistics for FA values of white matter ROIs ($N = 324$).

ROI	<i>M</i>	<i>SD</i>
Body of corpus callosum	0.719	0.031
Fornix	0.486	0.069
External capsule, right	0.473	0.024
External capsule, left	0.510	0.026
Cingulate gyrus, right	0.597	0.035
Cingulate gyrus, left	0.658	0.036
Superior longitudinal fasciculus, right	0.512	0.028
Superior longitudinal fasciculus, left	0.546	0.027

CFA

CFA results for models of WMIF, AUD Severity, Drinking Behavior, Liver Health, and Metabolic Health are displayed in Table 6. Results are given in standardized values.

The WMIF model provided a very good fit to the data. The final model allowed correlated errors between right- and left-hemisphere counterparts of the bilateral tracts and between the two midline tracts for a total of four correlated errors estimated in the model. This decision was made on the supposition that the extent to which the white matter atlas used to define the ROIs was a misfit for an ROI in one hemisphere would correlate with the degree of misfit for the same ROI in the other hemisphere, leading to correlated errors. Similar reasoning was applied to the midline tracts. All loadings for the WMIF model were significant, even though the loading for the fornix was relatively low, at .345. WMIF accounted for variance in the indicators ranging from $R^2 = .119$ for the fornix to $R^2 = .593$ for the left superior longitudinal fasciculus. Figure 4 shows the WMIF model.

Table 6. CFA results.

Factor	n	Indicator	Loading	RMSEA	RMSEA 90% CI	CFI	SRMR
WMIF	324	BCC	0.548	0.045	.004 - .074	0.993	0.024
		Fornix	0.345				
		EC R	0.697				
		EC L	0.575				
		CG R	0.724				
		CG L	0.741				
		SLF R	0.749				
		SLF L	0.770				
AUD Severity	305	ADS	0.868	0.000	—	1.000	0.000
		AUDIT	0.949				
		ICS	0.847				
Drinking Behavior A	286	DPDD	—	—	—	—	—
		PDD	—				
		Last drink	—				
Drinking Behavior B	295	DPDD	0.234	0.000	—	1.000	0.000
		PDD	0.442				
		PHDD	1.714				
Drinking Behavior C	286	DPDD	0.322	0.142	—	0.942	0.069
		PDD	0.502				
		Last drink	-0.089				
		PHDD	1.480				
Liver Health A	49	Bilirubin	0.122	0.366	—	0.107	0.107
		ALP	0.025				
		AST	0.944				
		ALT	0.874				
		GGT	0.571				
		LDH	0.142				
		MCV	0.365				
Liver Health B	49	AST	0.909	0.061	.000-.297	0.995	0.024
		ALT	0.906				
		GGT	0.589				
		MCV	0.354				
Metabolic Health A	50	BMI	0.745	0.271	—	0.877	0.080
		Waist	1.042				
		Triglycerides	0.380				
		Cholesterol	0.234				
Metabolic Health B	50	BMI	0.680	0.000	—	1.000	0.000
		Waist	1.139				
		Triglycerides	0.348				

Figure 4. Measurement model of the white matter integrity factor (WMIF). In all diagrams, circles indicate latent variables, and squares represent observed variables. Abbreviations: BCC = body of corpus callosum; CGL = cingulate gyrus, left; CGR = cingulate gyrus, right; ECL = external capsule, left; ECR = external capsule, right; FNX = fornix; SLFL = superior longitudinal fasciculus, left; SLFR = superior longitudinal fasciculus, right.

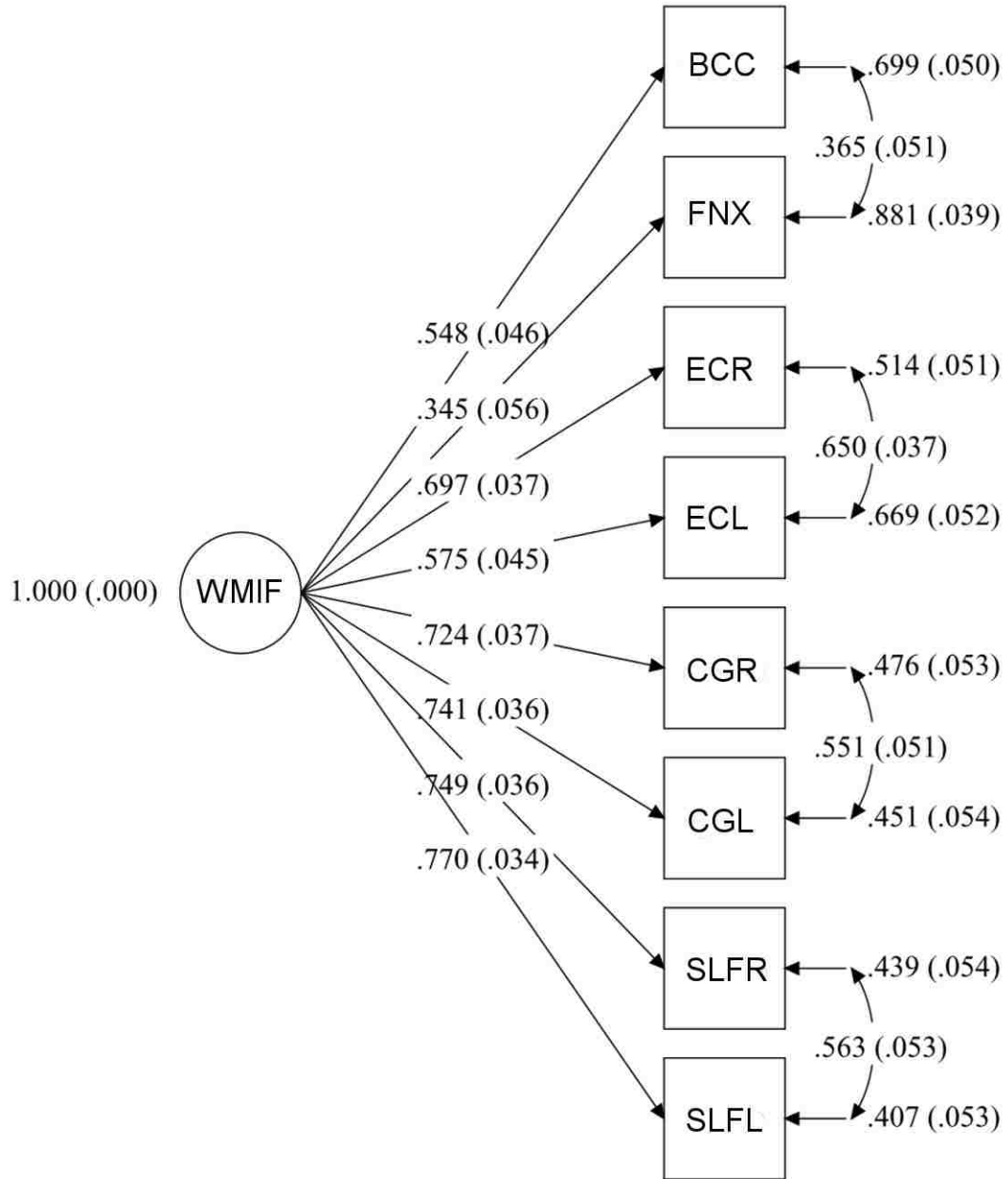

Analysis of measurement invariance of WMIF across treatment-naïve ($n = 209$) and treatment-seeking ($n = 115$) groups first fit the model in each group separately, yielding good fit in the treatment-naïve group (RMSEA = .052, CFI = .988, SRMR

= .030) and excellent fit in the treatment-seeking group (RMSEA = .000, CFI = 1.000, SRMR = .021). The test of non-invariance that included both groups in the same model but allowed group-specific parameter estimates had good fit (RMSEA = .044, CFI = .993, SRMR = .027). Next, factor loadings were constrained to equality across groups, and a χ^2 test showed no significant decrement in model fit [$\chi^2(8) = 11.607, p = .1696$]. Constraining loadings and intercepts to equality across groups did produce significantly worse fit [$\chi^2(7) = 46.668, p < .001$] than the model constraining loadings only. These results indicate that the basic factor structure was the same for both groups, with equivalent loadings but not intercepts of indicators. Therefore, indicators do not have the same predicted value across groups when the latent factor is zero.

Because AUD Severity was a just-identified model (i.e., the number of unique pieces of information exactly equaled the number of estimated parameters, leaving zero degrees of freedom), fit statistics necessarily showed a “perfect fit” to the data. However, all factor loadings were significant and very high, indicating that AUD Severity did in fact account for most of the variance in the indicators.

Three models of Drinking Behavior were estimated, and none provided a satisfactory fit to the data. Drinking Behavior A with DPDD, PDD, and last drink failed to converge. Drinking Behavior B with DPDD, PDD, and PHDD had perfect fit statistics because it was just-identified, yet errors arose in estimating the residual covariance matrix, and one loading exceeded an interpretable value. Finally, Drinking Behavior C with all four indicators demonstrated poor RMSEA but acceptable CFI and SRMR. Errors were encountered in the residual covariance matrix, and two indicators had

loadings that fell outside the interpretable range. Therefore, a cohesive factor representing Drinking Behavior did not emerge.

Due to limited availability of data, sample sizes for Liver Health and Metabolic Health models were far smaller than anticipated ($n = 49-50$). Therefore, the results of these analyses should be considered preliminary.

For Liver Health A, which included all seven laboratory tests, overall fit was very poor. Liver Health B, using only the indicators that had significant loadings in the previous model, demonstrated good fit; results should be interpreted cautiously given the absence of a priori selection and a wide confidence interval for RMSEA.

Metabolic Health A with BMI, waist circumference, triglycerides, and total cholesterol also was a poor fit. When only the indicators with significant loadings were retained in Metabolic Health B, estimation errors occurred in the residual covariance matrix, and one loading exceeded an interpretable value.

In sum, both WMIF and AUD Severity demonstrated very good model fit. Models of Drinking Behavior, Liver Health, and Metabolic Health largely failed to meet fit standards and/or produced estimation errors. Drinking Behavior, Liver Health, and Metabolic Health factors are not used in subsequent analyses.

Simple mediation

Results of simple mediation models are shown in Table 7. Results in tables are in standardized values. The standardized coefficient b is the change in the outcome in SD units for one SD change in the predictor. Parameter estimates and CIs of indirect effects are given in unstandardized values where noted in the text when assessing the significance of these effects.

Table 7. Simple mediation of the path from NYD to WMIF.

Mediator	<i>n</i>	RMSEA	CFI	SRMR	<i>a</i> path <i>p</i> -value	<i>b</i> path <i>p</i> -value	Indirect effect <i>p</i> -value	Direct effect <i>p</i> -value	<i>b</i>	<i>R</i> ²
ADS	303	0.102	0.939	0.065	<.001	0.006	0.029	0.003	-1.176	.100
AUDIT	303	0.105	0.935	0.07	<.001	0.207	0.222	0.002		
ICS	303	0.100	0.942	0.071	<.001	0.114	0.121	0.003		
DPDD	303	0.097	0.944	0.062	<.001	0.179	0.223	0.002		
PHDD	303	0.096	0.946	0.068	<.001	0.606	0.609	0.002		
PDD	303	0.097	0.944	0.066	<.001	0.044	0.066	0.004		
Last drink	293	0.098	0.942	0.062	0.645	0.346	0.773	0.001	-1.145	.090
Bilirubin	50	0.086	0.961	0.067	0.301	0.831	0.882	0.646		
ALP	50	0.164	0.869	0.085	0.905	0.744	0.968	0.602		
AST	50	0.132	0.912	0.079	0.367	0.358	0.604	0.482		
ALT	50	0.127	0.919	0.075	0.038	0.395	0.404	0.376		
GGT	50	0.116	0.93	0.077	0.834	0.535	0.911	0.595		
LDH	50	0.109	0.938	0.073	0.673	0.285	0.772	0.566		
MCV	50	0.117	0.929	0.078	0.399	0.790	0.864	0.582		
BMI	50	0.086	0.961	0.067	0.883	0.873	0.980	0.587		
Waist	50	0.094	0.954	0.068	0.307	0.315	0.566	0.513		
Triglycerides	50	0.115	0.931	0.077	0.268	0.842	0.883	0.631		
Cholesterol	50	0.092	0.955	0.073	0.061	0.460	0.534	0.759		

Notes: For significant mediators, *b* is the coefficient for the regression of WMIF on the mediator. *R*² is the variance accounted for in WMIF by the model.

Prior to adding mediators, the total univariate effect (*c* path in Figure 3) of NYD on WMIF was estimated, and this coefficient was significant ($b = -.266, p < .001$). Some commonalities were observed in models with ADS, AUDIT, ICS, DPDD, PHDD, PDD, and days since last drink. First, the direct effect (*c'*) from NYD to WMIF remained significant after addition of the mediator in all models. Second, the *a* path from NYD to the mediator was significant for all variables except last drink. Third, overall model fit was acceptable for each model according to CFI and SRMR but was poor to marginal according to RMSEA.

ADS and PDD emerged as the only mediators for which indirect effects were significant. The test of the total indirect effect was significant for ADS, and the CI did not include 0 (unstandardized estimate = $-.006$; 95% CI = $-.013$ — $-.002$). The *p*-value for the indirect effect of PDD only reached trend level, yet the CI did not include zero (unstandardized estimate = $-.006$; 95% CI = $-.012$ — $-.001$). Based on the rationale given in the Method section regarding bootstrapping and asymmetric CIs, it was concluded that PDD was a significant mediator.

Inadequate sample sizes for analyses involving the liver and metabolic variables meant that no conclusion could be drawn from the non-significant tests.

Multiple mediation

The objective of multiple mediation analyses was to determine the association of each mediator with the dependent variable while controlling for other mediators. In other words, analyses examined the unique contribution of each mediator in the context of the other mediators present in the model.

Table 8 presents the results of multiple mediation analyses. Again, analyses of the liver and metabolic variables were non-significant but underpowered and will not be discussed further.

Table 8. Multiple mediation of the path from NYD to WMIF.

Domain	<i>n</i>	RMSEA	CFI	SRMR	Mediator	<i>a</i> path <i>p</i> -value	<i>b</i> path <i>p</i> -value	Specific indirect <i>p</i> -value	Total indirect <i>p</i> -value	Direct <i>p</i> -value	<i>R</i> ²
Alcohol Severity	303	0.216	0.698	0.164	ADS	<.001	0.011	0.037	0.406	0.002	.151
					AUDIT	<.001	0.218	0.224			
					ICS	<.001	0.896	0.897			
Drinking Behavior A	293	0.085	0.935	0.07	DPDD	<.001	0.436	0.452	0.021	0.028	.116
					PDD	<.001	0.006	0.018			
					Last drink	0.673	0.149	0.746			
Drinking Behavior B	303	0.155	0.818	0.137	DPDD	<.001	0.041	0.080	0.218	0.007	
					PDD	<.001	0.002	0.006			
					PHDD	<.001	0.059	0.068			
Drinking Behavior C	293	0.144	0.812	0.122	DPDD	<.001	0.219	0.250	0.153	0.015	
					PDD	<.001	0.001	0.006			
					Last drink	0.668	0.204	0.759			
Liver Health	50	0.189	0.616	0.146	PHDD	<.001	0.189	0.215	0.693	0.533	
					Bilirubin	0.304	0.823	0.886			
					ALP	0.906	0.848	0.981			
Metabolic Health	50	0.171	0.765	0.274	AST	0.370	0.959	0.969			
					ALT	0.039	0.727	0.717			
					GGT	0.839	0.882	0.974			
					LDH	0.673	0.574	0.833			
					MCV	0.399	0.996	0.997			
					BMI	0.884	0.393	0.928	0.902	0.599	
					Waist	0.300	0.218	0.479			
Triglyc.	0.270	0.924	0.946								
Significant Mediators	303	0.093	0.937	0.068	ADS	<.001	0.016	0.060	0.007	0.02	.110
					PDD	<.001	0.054	0.076			

Notes: *R*² is the variance accounted for in WMIF by the model.

For the model including ADS, AUDIT, and ICS, overall model fit was poor according to all indices. At the same time, ADS significantly mediated the path from NYD to WMIF.

Three variations on the model of Drinking Behavior were tested because both last drink and PHDD were somewhat problematic indicators. The loading for last drink was not significant in any model. PHDD, on the other hand, may be redundant with both PDD and DPDD, as it reflects both frequency and quantity.

Drinking Behavior A with SQRTDPDD, PDD, and PHDD showed acceptable to marginal overall fit, as well as a significant specific indirect effect for PDD and total indirect effect. Drinking Behavior B and C showed poor overall fit, but indirect effects for PDD again were significant.

A posthoc multiple mediator model included only the two variables that were significant mediators in the simple and multiple mediator models, ADS and PDD (Figure 5). This model had acceptable values for CFI and SRMR and marginal RMSEA. The total indirect effect was significant. The *p*-values for specific indirect effects for ADS and PDD did not surpass trend levels. However, the CI around the indirect effect for ADS did not include 0 (unstandardized indirect effect = -.005; 95% CI = -.013 — -.001), indicating that it was a significant mediator. The CI for the indirect effect of PDD in this analysis did include zero, leading to the conclusion that it was not a significant mediator (unstandardized indirect effect = -.005; 95% CI = -.011 — -.000). Finally, a *z*-test of whether the indirect effects for ADS and PDD differed in magnitude (K. J. Preacher & Hayes, 2008) was non-significant (*p* = .973).

Figure 5. Partial multiple mediation of the path from NYD to WMIF by ADS and PDD. Abbreviations: ADS = Alcohol Dependence Scale; BCC = body of corpus callosum; CGL = cingulate gyrus, left; CGR = cingulate gyrus, right; ECL = external capsule, left; ECR = external capsule, right; FNX = fornix; NYD = number of years drinking; PDD = percentage of days drinking; SLFL = superior longitudinal fasciculus, left; SLFR = superior longitudinal fasciculus, right.

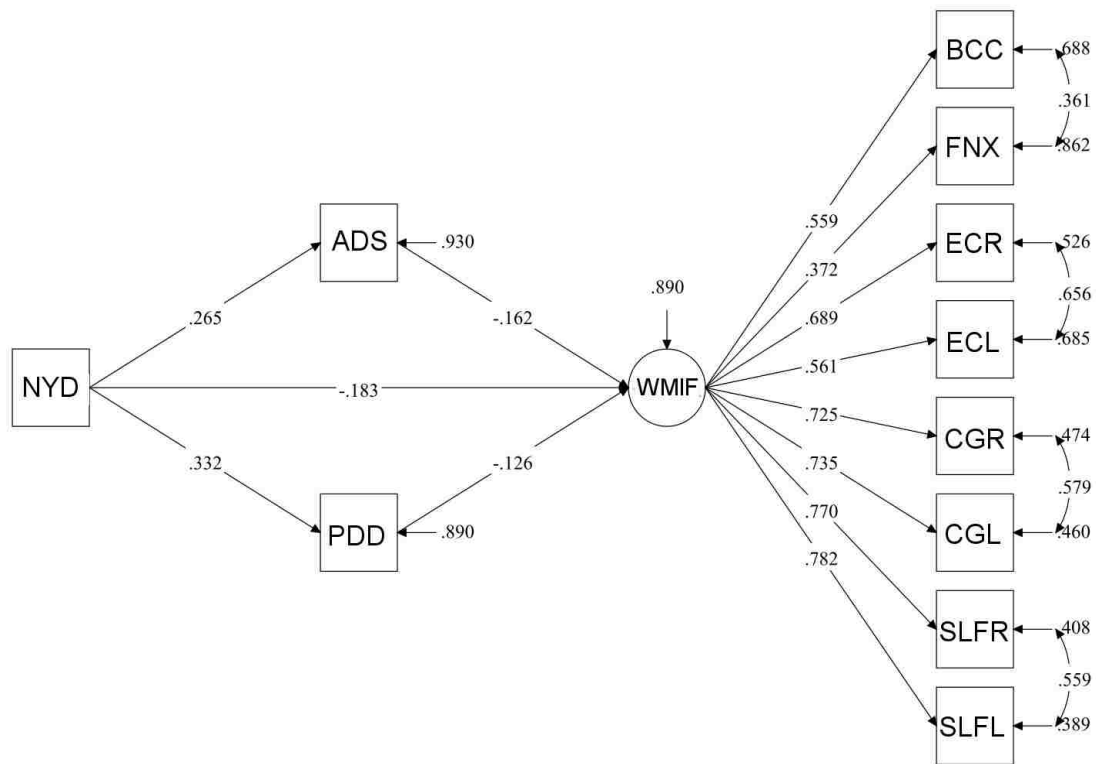

Interestingly, variance accounted for by the two models with reasonably good fit, Drinking Behavior A and Significant Mediators, barely exceeded the R^2 values of the simple mediation models for ADS and PDD. It appeared that additional mediators did not account for incrementally more variance in WMIF.

Mediation by latent variables

These models tested mediation of the path from NYD to WMIF by the factors with good fit in CFA, i.e., AUD Severity and Liver Health B. Results are given in Table 9. The Liver Health factor was not a significant mediator.

Table 9. Mediation by latent variables.

Factor	<i>n</i>	RMSEA	CFI	SRMR	<i>a</i> path <i>p</i> -value	<i>b</i> path <i>p</i> -value	Specific indirect <i>p</i> -value	Direct <i>p</i> -value
AUD Severity	303	0.091	0.945	0.074	< .001	0.061	0.079	0.005
Liver Health B	50	0.102	0.919	0.088	0.149	0.412	0.548	0.448

For the AUD Severity model, overall fit was acceptable according to CFI and SRMR and marginal according to RMSEA. The indirect effect of AUD Severity showed a trend toward significance. In comparison to this model, the multiple mediator model using observed scores of the same variables showed poor fit and a non-significant total indirect effect. By isolating the variance common to the three measures and eliminating measurement error, the latent factor model demonstrated a stronger effect of problem severity on WMIF than the multiple mediator model.

Moderated mediation

The goal of moderated mediation analyses was to test whether the magnitude of *a* or *b* paths in select simple mediation models depended on participant characteristics. A significant difference between the path estimates for each group (e.g., the *a* path for men versus the *a* path for women) indicates an interaction with that group characteristic. Separate models were created to test mediation by gender, treatment-seeking status, smoking status, and comorbidity.

Preliminary repeated-measures ANOVAs on the FA values of the 8 white matter ROIs tested for main effects. A significant main effect of group was found for treatment-seeking status [$F(1,311) = 15.965, p < .001$] and gender [$F(1,311) = 12.015, p = .001$]. FA of white matter ROIs was significantly lower in treatment-seeking participants compared to treatment-naïve participants and in females compared to males. The main

effect of group was not significant for smoking status or comorbidity. NYD was a significant covariate in all analyses (p 's < .001).

SEM investigated whether indirect effects in select simple mediation models differed by treatment-seeking status, gender, smoking status, or comorbidity. Table 10 shows selected results.

Table 10. Selected results of moderated mediation.

Moderator	Mediator	Path tested	χ^2	RMSEA	CFI	SRMR	Group	<i>a</i> path <i>p</i> -value	<i>b</i> path <i>p</i> -value	Specific indirect <i>p</i> -value	Direct <i>p</i> -value	R^2
Gender	ADS	<i>b</i>	0.187	0.104	0.917	0.187	Males	<.001	0.183	0.239	0.001	.087
							Females		0.008	0.040		.153
Gender	PDD	<i>b</i>	0.002	0.103	0.921	0.150	Males	<.001	0.817	0.818	0.002	.068
							Females		0.001	0.006		.263
Gender	PHDD	<i>b</i>	0.037	0.101	0.924	0.171	Males	<.001	0.722	0.725	0.001	.068
							Females		0.052	0.069		.171
Gender	AUD Severity	<i>b</i>	0.127	0.094	0.928	0.169	Males	<.001	0.546	0.566	0.002	.075
							Females		0.023	0.046		.143
Comorbidity	PDD	<i>a</i>	0.005	0.087	0.942	0.163	Low	<.001	0.043	0.053	0.005	.096
							High	0.222		0.330		.071
Smoking status	AUD Severity	<i>b</i>	0.137	0.078	0.950	0.156	Non-smokers	<.001	0.655	0.658	0.004	.064
							Smokers		0.007	0.018		.136

Notes: R^2 is the variance accounted for in WMIF by group.

First, simple mediation models tested whether magnitude of *a* or *b* paths in models with ADS, AUDIT, or ICS depended on treatment-seeking status. None of these tests were significant. Given that AUDIT and ICS were not significant mediators in the previous models and to reduce the number of tests, ADS was selected as the problem severity mediator when testing moderation by gender, smoking status, and comorbidity. When testing gender as a moderator of the *b* path, it was found that the indirect effect of NYD through ADS was significant for women but not for men. A plot of this relationship (Figure 6) displayed a negative, linear relationship between ADS and WMIF factor scores for women but not men. Because the χ^2 difference test comparing the *b* path between genders was non-significant, however, gender did not significantly moderate the indirect effect of ADS.

Figure 6. Relation between ADS and WMIF score by gender. For men, $R^2 = .032$; for women, $R^2 = .142$

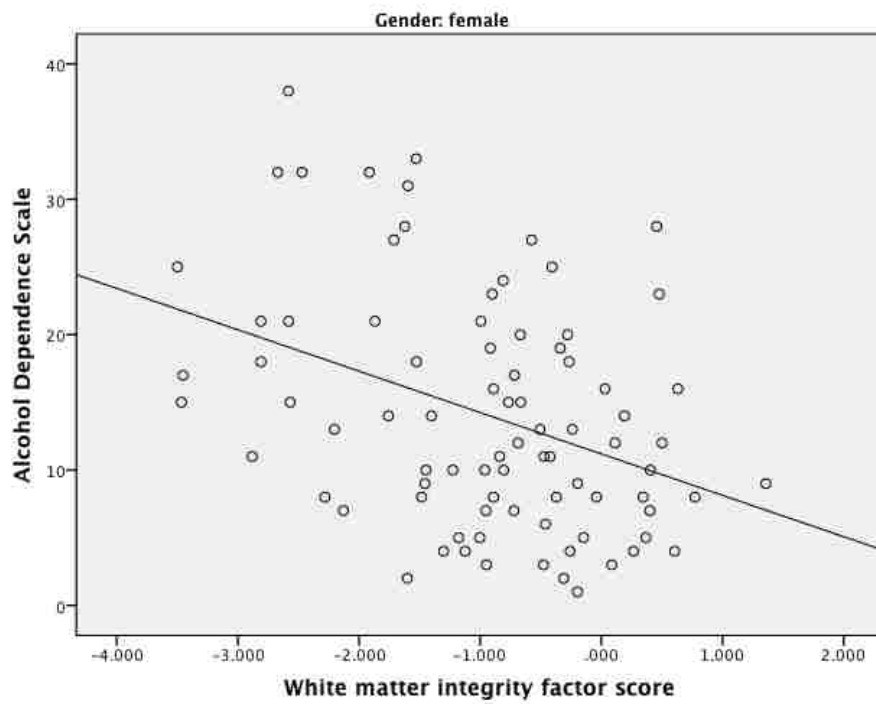
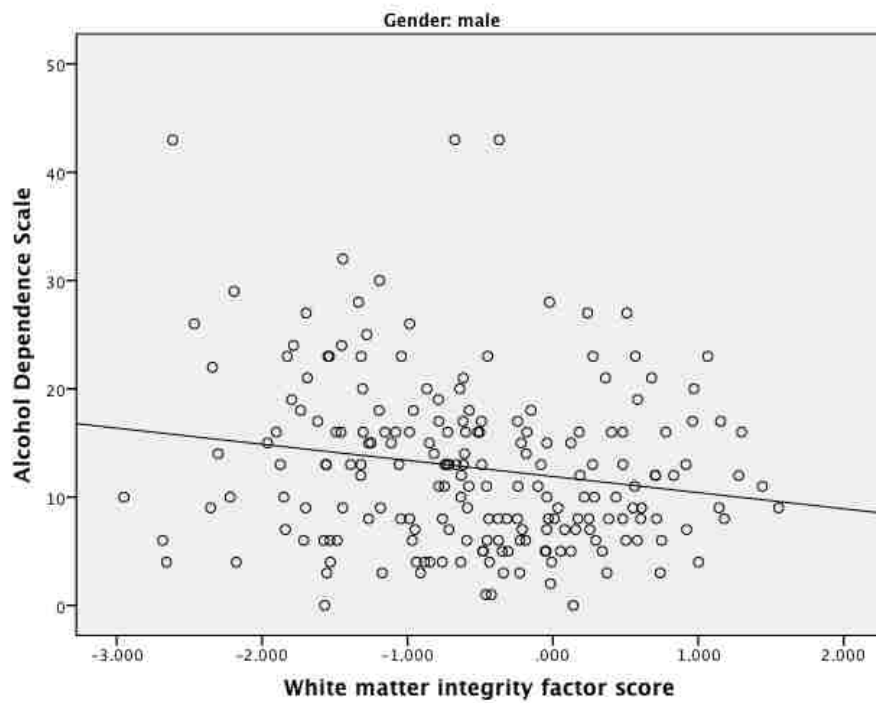

Moderated mediation for drinking behavior variables tested PDD, DPDD, and PHDD in models with treatment-seeking status and gender. Only PDD was tested in models with smoking status and comorbidity. The rationale was to limit the number of tests by selecting the variable that performed best in simple and multiple mediation analyses. Last drink was not tested in moderated mediation models because the path from NYD to last drink in simple mediation was non-significant.

In a model with PDD as mediator, gender significantly moderated the *b* path. The path from PDD to WMIF was significant for women but not for men, such that frequency of drinking had a negative effect for WMIF only in women (see Figure 7). Similarly, gender significantly moderated the *b* path for the indirect effect of PHDD. The effect of PHDD appeared negative for women but not for men; however, *p*-values for the *b* path and indirect effect for women reached only trend levels, and 95% CI for the indirect effect did include 0.

Figure 7. Relation between PDD and WMIF score by gender. Gender was a significant moderator of the indirect effect of NYD to WMIF through PDD. For men, $R^2 = .011$; for women, $R^2 = .280$.

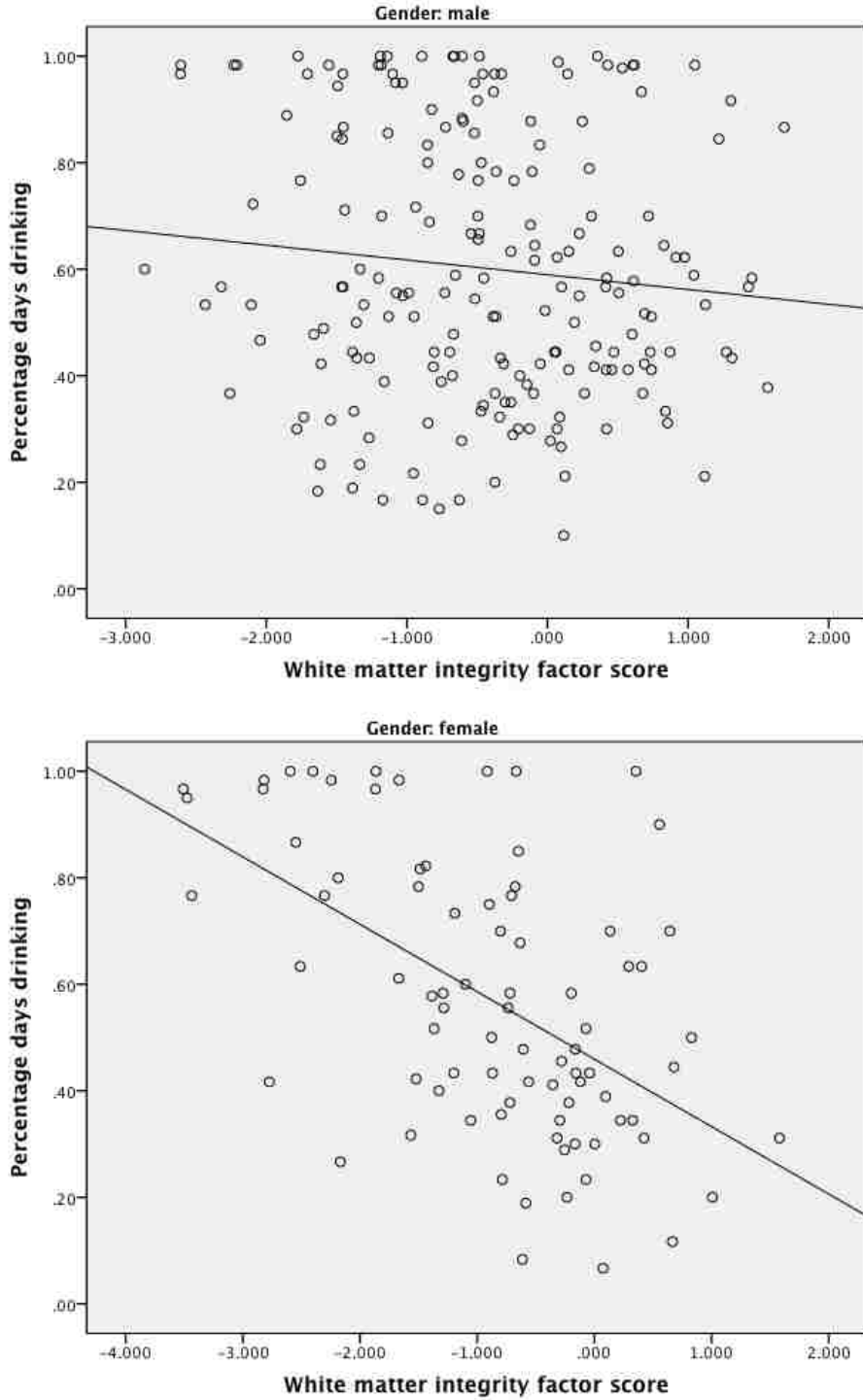

In testing comorbidity as a moderator of the indirect effect through PDD, the effect was significant for the *a* path. NYD was significantly, positively related to PDD in the low comorbidity group but not in the high comorbidity group. However, the indirect effect within the low comorbidity showed only a trend toward significance, and its 95% CI did include 0.

Finally, a model was constructed to test moderation of the indirect effect through the AUD Severity latent variable. The χ^2 difference test yielded no evidence of moderation by treatment-seeking status, gender, smoking status, or comorbidity. However, for women but not men, the *b* path ($b = -.245$; $p = .023$) and indirect effect through AUD Severity were significant and negative. Similarly, for smokers but not non-smokers, the *b* path ($b = -.229$; $p = .007$) and indirect effect through AUD Severity also were significant and negative. These findings do not provide direct evidence of moderation but merely suggest a trend toward differential magnitude of indirect effects in these groups.

WMIF and cognitive functioning

Cognitive data were available for 137 participants (31 treatment-naïve, 106 treatment-seeking). All participants were retained in the following models because missing data were handled by ML estimation procedures (Baraldi & Enders, 2010). Average raw scores were 55.49 ± 10.43 (range = 22-76) for Vocabulary and 25.65 ± 5.55 (range = 9-35) for Matrix Reasoning. As predicted, WMIF was significantly, positively associated with Matrix Reasoning ($b = .268$; $p = .001$) but not Vocabulary ($b = -.003$; $p = .968$). Also as expected, NYD was significantly, negatively associated with Matrix Reasoning ($b = -.401$; $p < .001$) but not Vocabulary ($b = -.023$; $p = .791$). For the model

testing WMIF as mediator of the path from NYD to Matrix Reasoning, overall fit statistics were good to marginal (RMSEA = .098; CFI = .942; SRMR = .068). Effects were significant for a ($p = .001$) and b ($p = .021$) paths. Although the p -value for the indirect effect was .104, the CI did not include zero (unstandardized indirect effect = -.032; 95% CI = -.081 — -.005), leading to the conclusion that it was significant.

As hypothesized, treatment-seeking status significantly moderated the mediation effect [$\chi^2(1) = 9.918, p = .001$], specifically the b path. The b path was significant and positive only for the treatment-seeking group ($b = .233; p = .010$). Figure 8 displays the relation between WMIF scores and Matrix Reasoning by group.

Figure 8. Relation between Matrix Reasoning score and WMIF score by treatment-seeking status. Treatment-seeking status was a significant moderator of the path from NYD to Matrix Reasoning through WMIF. Note that scatterplots only show participants with Matrix Reasoning scores, but statistical analysis used the entire sample, using ML estimation to address missing data. For treatment-naïve group, $R^2 = .067$; for treatment-seeking group, $R^2 = .104$.

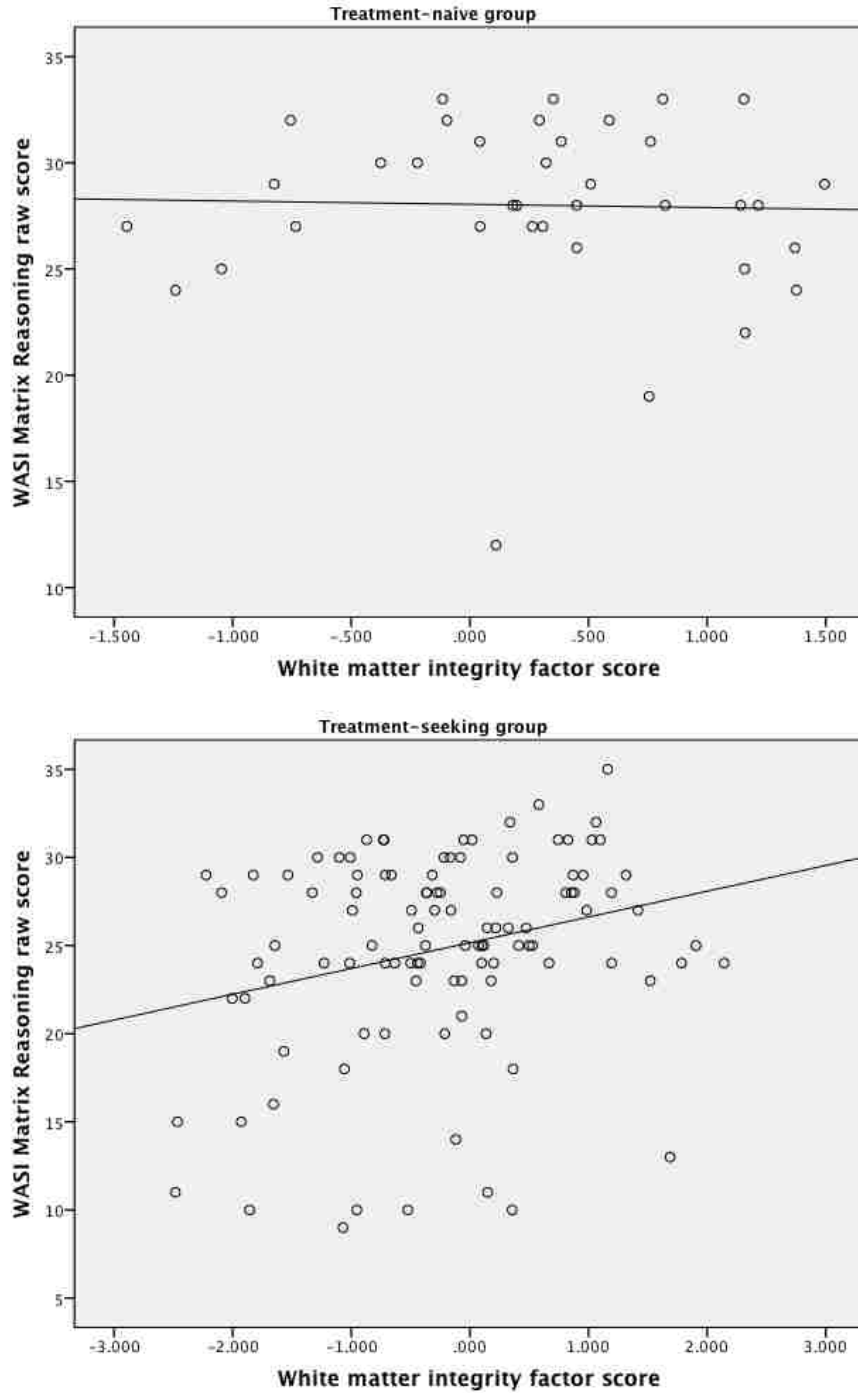

As noted above, age has significant, negative effects on white matter integrity (Hsu, et al., 2008; Inano, Takao, Hayashi, Abe, & Ohtomo, 2011). Advancing age also correlates with decline in visuospatial performance (Lezak, et al., 2004), although this effect may not be apparent in the relatively young age range of this sample (21-56 years). Consequently, two additional models examined whether age was driving the effects reported above. Diagrams of these models and the original model without age are shown in Figure 9. A model controlling for the effect of age on both WMIF and Matrix Reasoning showed marginal overall fit (RMSEA = .098; CFI = .930; SRMR = .085). Interestingly, only the path from WMIF to Matrix Reasoning remained significant in this model; paths from age and NYD to either WMIF or Matrix Reasoning were not significant (see diagram for parameter estimates and *p*-values). Total and specific indirect effects were not significant. In the second model controlling for the effect of age on Matrix Reasoning but omitting the path from age to WMIF, the path from NYD to WMIF was significant, as was the path from WMIF to Matrix Reasoning. The overall indirect effect of NYD on Matrix Reasoning was significant according to the CI (unstandardized indirect effect = -.029; 95% CI = -.078 — -.002). The paths from age and NYD to Matrix Reasoning were non-significant.

Figure 9. Three models of drinking history, white matter integrity, and visuospatial functioning: A) original model without adjustment for age; B) model controlling for effects of age on WMIF and Matrix Reasoning (indicators of WMIF not shown); C) model controlling for effect of age on Matrix Reasoning (indicators of WMIF not shown).

A)

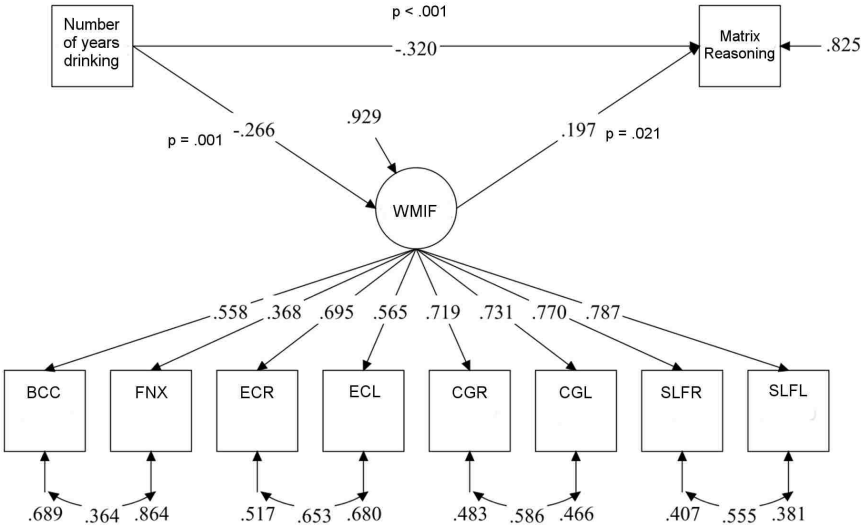

B)

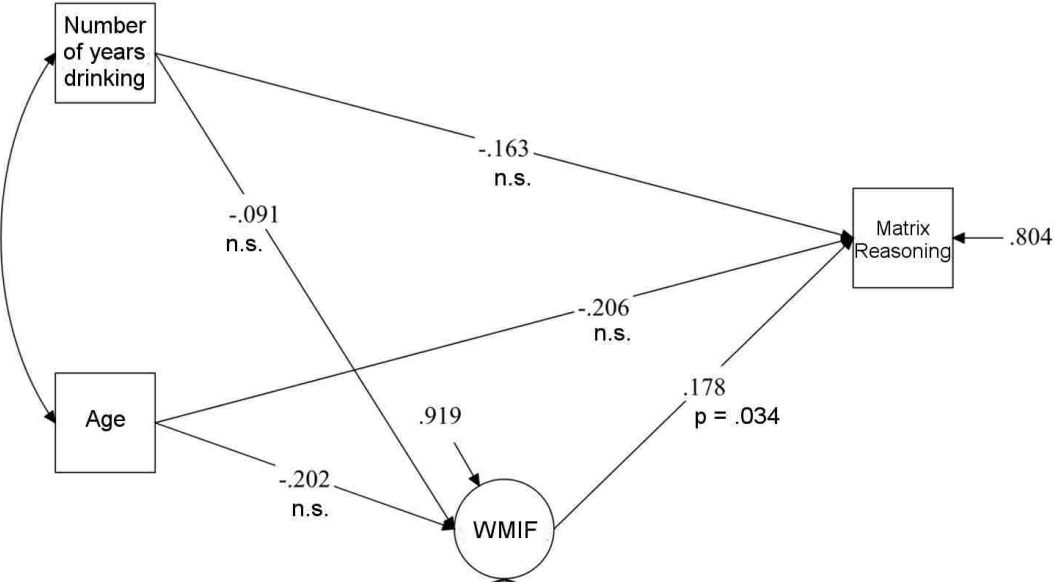

C)

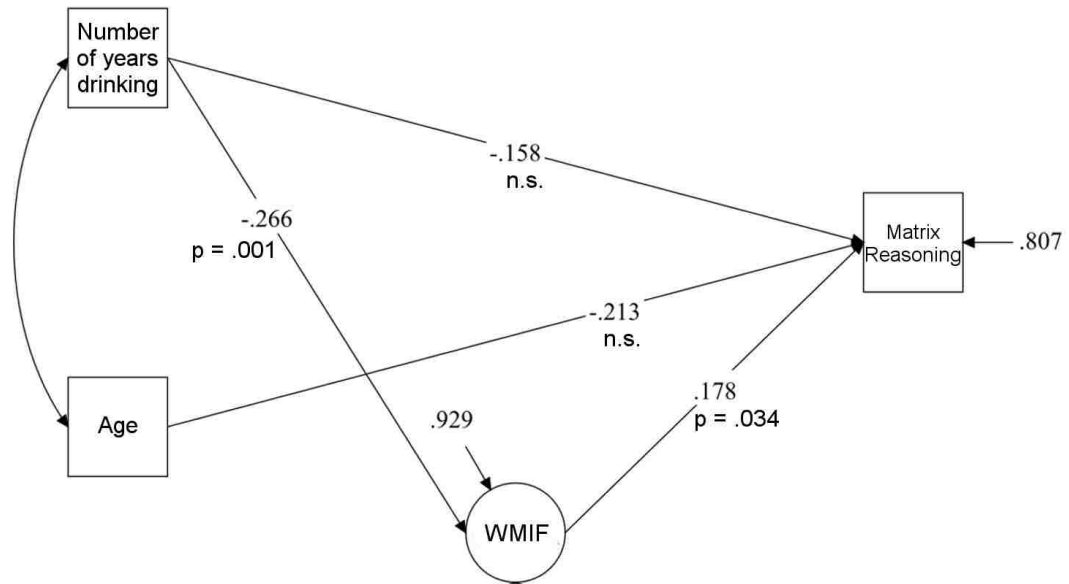

Exploratory analysis

An exploratory model tested whether perceived loss of control over drinking (i.e., ICS score) mediated the direct path from lower white matter integrity to increased DPDD. First, WMIF showed significant regression coefficients as a predictor of DPDD ($b = -.171, p = .007$) and ICS ($b = -.176, p = .005$). Next, a mediation model tested the indirect effect of WMIF on DPDD through ICS. This model had good overall fit (RMSEA = .062, CFI = .976, SRMR = .050). The indirect effect through ICS was significant ($p = .009$), and the direct path was no longer significant ($p = .204$), indicating full mediation. The variance accounted for in DPDD was relatively high ($R^2 = .254$). Figure 10 shows this model.

Figure 10. Full mediation of the path from WMIF to DPDD by ICS. Abbreviations: BCC = body of corpus callosum; CGL = cingulate gyrus, left; CGR = cingulate gyrus, right; DPDD = drinks per drinking day; ECL = external capsule, left; ECR = external capsule, right; FNX = fornix; ICS = Impaired Control Scale; SLFL = superior longitudinal fasciculus, left; SLFR = superior longitudinal fasciculus, right.

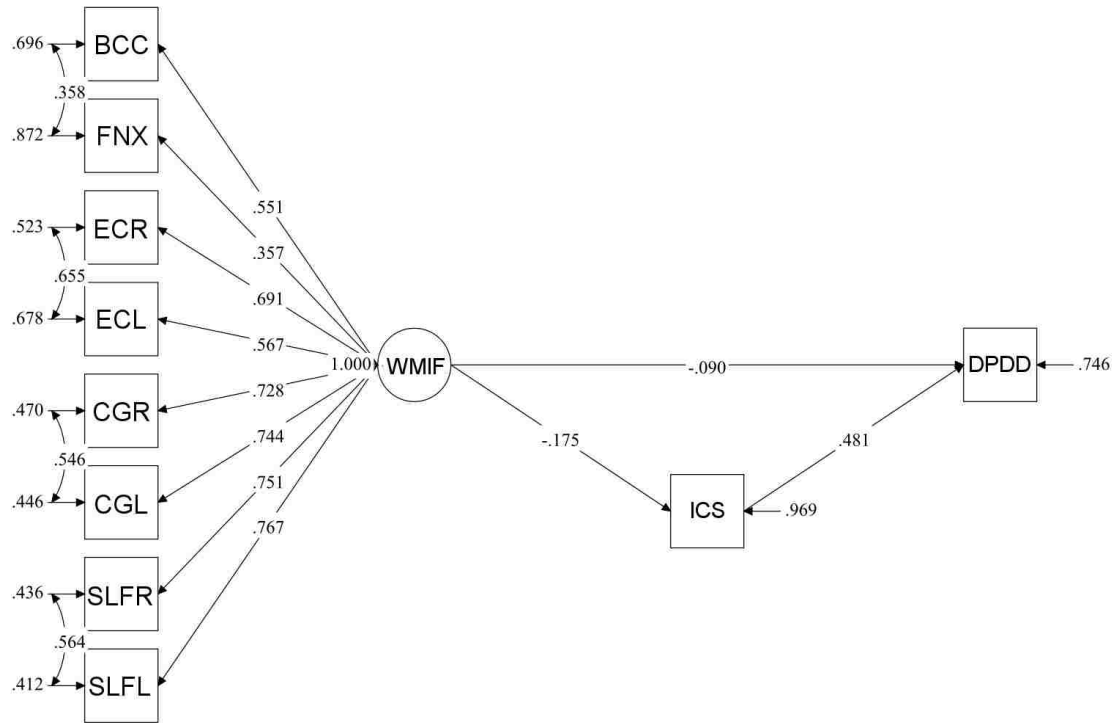

Although cross-sectional design prohibits inferences about causal mechanisms, tests of alternative models can assist in evaluating the credibility of the proposed directionality of effects. One alternative model was that higher DPDD would predict greater loss of control and that this effect would be mediated by lower WMIF, following the concept that binge drinking is a self-perpetuating cycle in which heavy drinking impairs the ability to inhibit future heavy drinking through alcohol-related white matter damage. Another possibility was mediation of a direct path from ICS to DPDD ($b = .498$, $p < .001$) by lower white matter integrity, which conceptually would posit that loss of control leads to greater intensity of drinking through lower white matter integrity. For both alternative models, overall fit was similar to the original, but the indirect effect was

non-significant. A preliminary implication of these model comparisons is that white matter integrity appears to influence drinking behavior through one's ability to control drinking behavior. Replication of this finding with an independent sample and temporally lagged design is necessary before drawing causal inferences.

Discussion

Primary findings

This study investigated factors contributing to variability in white matter integrity of tracts associated with alcohol cue reactivity in heavy drinkers (M.A. Monnig, et al., under review). A latent variable was formed to represent FA values of the middle segment of corpus callosum, fornix, external capsule, cingulum, and superior longitudinal fasciculus. Previous studies have found lower FA of these tracts in AUD groups relative to healthy comparison groups (Harris, et al., 2008; M. A. Monnig, Caprihan, et al., 2012; Pfefferbaum, et al., 2009; Yeh, et al., 2009). The tracts under study comprise intrahemispheric cortical association fibers, bidirectional corticolimbic projection fibers, and commissural fibers. Although the tracts do not conform to a single, discrete “circuit” in the brain, all are involved in higher-order sensorimotor and cognitive functioning. The superior longitudinal fasciculus is an extensive tract that connects frontal, parietal, and temporal cortices and participates in visuospatial, sensorimotor, and attentional functions (Fernández-Miranda, Rhoton, Alvarez-Linera, et al., 2008; Schmahmann, et al., 2008). The cingulum and fornix, structures in the limbic network, are primary to emotional experience and memory functions. Tractography studies have demonstrated that the external capsule receives inputs from a wide variety of cortical and limbic areas and suggest that it plays a role in multimodal sensory integration through its connectivity with the claustrum (Fernández-Miranda, Rhoton, Kakizawa, et al., 2008). The body of corpus callosum facilitates communication between contralateral motor regions and posterior parietal cortices (Hofer & Frahm, 2006).

Both a self-report measure of alcohol problem severity (ADS) and the frequency of drinking in the past 60 to 90 days (PDD) significantly mediated the relation between chronicity of alcohol exposure (NYD) and white matter integrity (WMIF) in these tracts. Current models of substance abuse posit a dominance of subcortical systems of reward-seeking over cortical systems that facilitate self-regulation, insight, and executive decision-making (Koob, 2006; Koob & Volkow, 2010). This imbalance is thought to arise from both genetic predisposition and repeated experience with substances of abuse. The results of the current study can be interpreted as indirect support for this model. The finding that greater problem severity and frequency of drinking contributed to lower FA in corticocortical and corticolimbic tracts involved in both reward-seeking and cognitive control systems at the very least suggests a bidirectional process between the complex behavior of problem drinking and the white matter pathways of these neurobiological networks. The cross-sectional study design limited ability to test causal links proposed in the neurobiological model of substance use disorders. At the same time, the working model tested here lends credence to the theory that oxidative stress processes activated by alcohol lead to neurodegeneration of corticolimbic networks, in turn diminishing an individual's ability to self-regulate substance use behaviors.

The significance of ADS as a mediator provides novel evidence that problem severity mediates the association of greater chronicity of alcohol exposure with lower white matter integrity. As an instrument, ADS covers a broad spectrum of phenomena related to problem drinking, including perceptual and physiological consequences, preoccupation with alcohol, and loss of control over drinking. In contrast, the AUDIT is a briefer measure primarily intended for use as a screening instrument, and the ICS focuses

on the individual's perceived, attempted, and failed control over drinking. This difference may account for the finding that, among ADS, AUDIT, and ICS, only ADS was a significant mediator in spite of a very high level of shared variance.

The significance of frequency of drinking (PDD), but not quantity per occasion (DPDD) or frequency of heavy drinking (PHDD), may be somewhat surprising, given the dose-dependent neurotoxicity of alcohol. One possible explanation for the significance of PDD but not DPDD or PHDD is that all participants regularly drank at binge levels by virtue of the study inclusion criterion. The significant correlation between frequency of drinking and frequency of *heavy* drinking, at $r = .752$, indicates that binge drinking was the modal behavior for most participants. As a result, simple frequency of drinking may have best captured an individual's recent degree of alcohol exposure.

Associations of problem severity and drinking behavior variables with brain structure have been highly inconsistent in the literature, with some studies linking abnormality to quantity or frequency of drinking and others reporting no association (Crews & Nixon, 2009). Differences in the particular region or structure under study, methods of quantifying drinking behavior, and sample characteristics are likely sources of variability. Consequently, the present results should be interpreted within the confines of the study conditions.

Interpretation of PDD as a mediator must take into account the finding that gender significantly moderated this effect, with women but not men showing a significant, negative association between PDD and WMIF. Gender also moderated the path from frequency of heavy drinking to white matter integrity. Although the χ^2 test of moderation was significant for both PDD and PHDD, the indirect effect through PHDD did not

exceed trend level. Regarding generalizability, the interaction of gender with the path from PDD to white matter integrity suggests that the importance of PDD is specific not just to heavy drinkers but to women who are heavy drinkers. DPDD or PHDD might play a stronger role for women engaging in a range of consumption that includes more light-to-moderate drinking.

The moderating effect of gender is particularly compelling in light of the fact that men and women were highly similar in other demographic characteristics, drinking history, and self-reported problem severity. Only DPDD differed between men and women, with men consuming approximately two more DPDD than women. This difference is commensurate with typical gender differences in body mass and subsequent blood alcohol concentration, however. Consequently, the moderating effect of gender cannot be attributed to confounding differences in age, drinking behavior, or problem severity. This finding contributes to the ongoing debate as to whether women suffer greater, lesser, or comparable brain damage relative to men with similar duration and quantity of drinking. Current results indicate that, in men and women with similar drinking profiles, greater frequency of drinking is associated with lower white matter integrity of tracts involved in alcohol cue reactivity in women but not men.

Interpreting the main effect of gender is not straightforward, as many studies have reported sexual dimorphism in healthy individuals for DTI metrics of numerous white matter tracts. Previous research has shown that men tend to have higher FA in the bilateral ROIs in this study, whereas there is less consistent evidence that women might have higher FA in corpus callosum and fornix (Inano, et al., 2011; Kanaan et al., 2012;

Kang, et al., 2011). In sum, the finding of lower FA in women should not be interpreted as a direct correlate or consequence of AUD, as it may reflect normal gender differences.

Consistent with the results of the simple mediation analysis, only ADS and PDD emerged as significant mediators when tested in combination with other variables. The multiple mediator model with these two variables can be interpreted as a comparison of the variance accounted for by one variable when controlling for the effect of the other. This overall model showed reasonably good fit, and the overall indirect effect was significant. The specific indirect effect was significant for ADS but not PDD, and these effects did not differ significantly from each other. One interpretation is that ADS and PDD each serve as relatively strong predictors of WMIF even when accounting for the other, but ADS has a slight advantage. Also of note was that the variance accounted for in the model with ADS and PDD only slightly exceeded that of ADS alone, suggesting the multiple mediation model was not a major improvement over the simpler model.

Comorbidity moderated the path from NYD to PDD such that frequency increased linearly with chronicity of drinking for the low comorbidity group. The high comorbidity group showed no association between NYD and PDD. This result was not predicted, and interpretation is speculative. One possibility is that individuals with higher levels of anxiety and depression progressed more rapidly to frequent drinking due to the negative reinforcement value of alcohol or lack of alternative coping skills for dealing with negative affect. Seeing as the high comorbidity group reported greater AUD severity, an alternative possibility is that individuals with more severe AUD simply drank more heavily and experienced stronger anxiety and depression symptoms as a consequence.

Treatment-seeking status was a significant moderator only in the model of cognitive functioning. Important to note, the absence of other interaction effects for treatment-seeking status does not contradict previous literature finding structural brain differences by treatment-seeking status. When white matter tracts were input as repeated measures in ANOVA, the treatment-seeking group showed lower white matter integrity than the treatment-naïve group, consistent with previous findings of greater impairment and/or abnormality in the treatment-seeking population (Gazdzinski, Durazzo, Weiner, & Meyerhoff, 2008a). This main effect may be attributable to significantly greater problem severity and consumption on every measure in the treatment-seeking group. Findings extend previous research in showing that mechanisms affecting white matter integrity in the tracts of interest do not operate differentially depending on treatment-seeking status, as mediation by problem severity or drinking behavior did not interact with treatment-seeking status. In contrast to postulating different mechanisms by treatment-seeking status, results seem to indicate that differences are a function of problem severity. One clinical implication is that treatment-seeking status may represent a multidimensional (i.e., behavioral, psychological, neurobiological) proxy signaling the likelihood of greater neurobiological abnormality in individuals presenting for AUD treatment.

White matter integrity and cognition

A priori hypotheses about relations among WMIF, NYD, and cognitive functioning were supported. Both WMIF and NYD were significant as independent predictors of Matrix Reasoning, which measures fluid visuospatial ability and abstraction, but not Vocabulary, which draws on crystallized verbal knowledge and memory retrieval. This specificity of white matter integrity for visuospatial ability is consistent with the

known functions of the tracts included in the model, especially the superior longitudinal fasciculus. A simple mediation model showed that white matter integrity partially mediated the path from duration of drinking to visuospatial scores. Subsequent models controlling for the effect of age on white matter integrity and/or cognitive scores gave the impression that the results of the original model were not attributable to age.

Matrix Reasoning scores, but not Vocabulary scores, were significantly lower in the treatment-seeking group. As predicted, treatment-seeking status was a significant moderator of the cognitive model. Treatment-seeking status interacted with the path from white matter integrity to visuospatial scores such that the relation was significant and positive for treatment-seeking but not treatment-naïve individuals. In the context of previous studies identifying cognitive deficits in treatment-seeking but not treatment-naïve individuals (Fein, et al., 1990; S. Smith & Fein, 2010), this finding suggests that decline in white matter FA accompanies cognitive impairment in the treatment-seeking population. One interpretation is that those seeking treatment have progressed further in manifesting the neurobehavioral effects of excessive drinking, such as cognitive decline arising from lower white matter integrity. An alternative explanation is that lower premorbid visuospatial functioning is correlated with lower FA and a predisposition to developing alcohol problems. Indeed, several studies have identified visuospatial deficits in young adults or adolescents who have family history of AUD but no personal substance abuse history, e.g., (Garland, Parsons, & Nixon, 1993; Thoma et al., 2011). Regardless of pathophysiological mechanisms, one clinical implication is that a client presenting for AUD treatment may experience difficulty with abstraction or reasoning

despite normal verbal expression. In such a circumstance, a clinician may wish to provide further neurocognitive assessment or more comprehensive therapeutic support.

Because some tracts included in the WMIF have been more closely linked to cognitive functioning than others, follow-up analyses testing tract-specific relations between FA values and cognition would be a helpful next step. In particular, the superior longitudinal fasciculus plays a prominent role in visuospatial awareness and processing and would be a likely candidate to mediate the path from NYD to WMIF.

In some models, the indirect effect of a mediator was significant for one group but not the other in the absence of a significant χ^2 difference test for the moderation effect. For example, the indirect effects of ADS and AUD Severity were significant for women but not men, and the indirect effect of AUD Severity was significant for smokers but not non-smokers. In these cases, moderation was not directly instantiated, yet differential effects were consistent with other results and/or previous research and so might warrant consideration in future studies.

Loss of control over drinking

Exploratory models diverged from the foregoing analyses by using WMIF as a predictor rather than dependent variable. The primary model showed that the path from white matter integrity to drinking intensity (DPDD) was fully mediated by scores on a self-report measure of loss of control over drinking (ICS). The theoretical foundation of this analysis asserts that white matter integrity affects drinking behavior specifically through the role of white matter networks in self-regulation and executive function. The tracts included in the model of white matter integrity were chosen for their association with alcohol cue reactivity, which is a neurobiological component of behavioral response

(M.A. Monnig, et al., under review). The superior longitudinal fasciculus and cingulate gyrus in particular are involved in higher-order perception and behavioral control (M. X. Cohen, et al., 2005; Fernández-Miranda, Rhoton, Alvarez-Linera, et al., 2008; Rogers, et al., 2004; Schmahmann, et al., 2008). In sum, findings present novel evidence of the link between white matter integrity and the phenomenon of loss of control over drinking.

Alternative models representing different constructions of these relationships did not have significant mediation effects. One caveat was that the direct path from ICS to the drinking outcome was far stronger than the direct path from WMIF to the drinking outcome. Hence, the model using ICS as mediator of the path from WMIF to the drinking outcome may have gained an advantage from the strength of bivariate associations rather than the underlying conceptual model.

Limitations

This study has several important limitations. Foremost, all data were cross-sectional, meaning that causal inferences cannot be made (MacCallum & Austin, 2000). As noted above, cross-sectional design is less problematic for the model in which the argument could be made that effects are instantaneous. Overall, however, a complex set of assumptions must be met in order for causal inferences to be made in SEM, and analyses herein do not satisfy those assumptions (B. O. Muthen, 2011). The absence of a randomized, experimental manipulation and the lack of temporal precedence for independent variables and mediators bear the implication that results are essentially correlational.

A further liability of the cross-sectional design is inability to test the hypothesis that a substantial proportion of the variation in white matter integrity existed prior to the

onset of problem drinking. An investigation comparing substance-naïve 11- to 15-year olds with negative or positive family history of AUD reported significantly lower FA for the latter in the superior longitudinal fasciculus and external capsule, two of the ROIs in the present study (Herting, Schwartz, Mitchell, & Nagel, 2010). Another recent study comparing young adults with high and low family density of alcohol dependence found that the interaction of family density with personal drinking history, but not either factor alone, was associated with FA of the inferior longitudinal fasciculus and superior longitudinal fasciculus. However, results were difficult to interpret given significant group differences in age and personal diagnosis of AUD (Hill, Terwilliger, & McDermott, 2013). On the other hand, another study of substance-abusing youth failed to find an effect of family history on FA of any tract (except the crus cerebri) or an interaction with personal substance use (Bava et al., 2009). Although the possibility of premorbid differences in white matter integrity should not be discounted, it seems unlikely that this factor could account entirely for the results presented here.

In this sample of individuals aged 21-56 years, duration of regular drinking (NYD) was highly confounded with age ($r = .877$; $p < .001$). It is possible that many of the significant effects identified in this study would be attenuated if age were included in the models. Large studies of healthy individuals have reported a negative, linear effect of age on FA. In a sample of 346 healthy participants ranging 25-81 years of age, age was inversely associated with FA [$R^2 = .11$; (Hsu, et al., 2008)]. Similarly, a study of 857 healthy individuals aged 25-85 years found a global negative correlation between age and FA [$R^2 = .18$; (Inano, et al., 2011)]. Specific tracts showing age-related decrease included the fornix, external capsule, and cingulum. On the other hand, the same study identified

age-related FA increase in several ROIs, including the superior longitudinal fasciculus (Inano, et al., 2011). Although the normative, global effect of age on FA is negative, tract-specific effects are less consistent, making it difficult to determine an appropriate statistical adjustment to account for a potential effect of age.

A related weakness is the use of NYD, rather than duration of heavy drinking or AUD, as the independent predictor of WMIF. NYD captured how long the participant reported drinking regularly, without distinguishing between moderate and problematic drinking. It is likely that a proportion of participants drank regularly without problematic or binge drinking prior to the onset of heavy drinking. NYD had a strong, direct relation with WMIF and is a reasonable index of chronic exposure to alcohol. However, it is not an optimal representation of the construct of interest, which is duration of heavy drinking.

Also worth noting is the absence of information on AUD diagnosis. Although inclusion criteria required participants to drink at hazardous levels on a regular basis, AUD diagnosis is based on drinking-related phenomena and consequences rather than quantity or frequency. As a result, it is possible that some participants did not meet criteria for alcohol abuse or dependence. Data on AUD diagnosis were not uniformly available at the time of data analysis but would be informative for future models.

Correction for multiple comparisons has received relatively little attention in the rapidly advancing literature on applied SEM. Because the objective in SEM is to hone in on the model with the best fit to the data, less emphasis is given to significance testing than in traditional hypothesis testing. In the latter, limiting the number of tests is seen as protective, whereas the SEM literature often recommends testing all plausible alternatives to the hypothesized model (Jackson, et al., 2009; MacCallum & Austin, 2000). This study

sought to strike a balance between these disparate perspectives by adhering closely to a priori hypotheses, choosing mediators that performed well instead of testing all mediators, and testing only a select number of alternative models. In addition, creating a latent variable to represent WMIF reduced eight ROIs to a single dependent variable, dramatically reducing the potential number of tests.

The number of ways a white matter outcome variable could be defined was practically infinite, given the number of tracts on the standard atlas and their possible combinations. This study constructed a latent factor representing WMIF on the basis of a previous multimodal imaging study showing an inverse association between FA values of the selected tracts and BOLD response to an alcohol taste cue (M.A. Monnig, et al., under review). Therefore, interpretation of findings is limited to those tracts. Although the WMIF possessed many advantages over observed variables, nevertheless it prevented the evaluation of tract-specific effects.

Days since last drink, the measure of drinking recency, showed a very restricted range in this sample. Therefore, the potential role of last drink as a mediator would benefit from investigation in a sample with greater variability on this measure.

Although ML estimation is a robust method of handling missing data, the large proportion of participants missing cognitive scores nevertheless may pose a problem. ML estimation is robust to missing data to the extent that missing data are accounted for by available data, an assumption that may or may not be met in this dataset. Comparing results with and without inclusion of participants missing cognitive scores would be informative in this regard.

Finally, the import of liver and metabolic variables could not be evaluated effectively due to limited data availability. No conclusions can be drawn about the lack of significance of these variables at this time.

Conclusions

Alcohol problem severity and frequency of drinking mediated the path from chronicity of drinking to white matter integrity in heavy drinkers. Variance accounted for in white matter integrity was $R^2 = .100$ for ADS and $R^2 = .090$ for PDD, compared to $R^2 = .071$ for the simple univariate relation between NYD and white matter integrity. Although small in both absolute magnitude and incremental improvement, these effect sizes suggest that individual differences in drinking severity and frequency do significantly impact white matter integrity.

Gender moderated the indirect effect of drinking frequency on white matter integrity. Notably, the path from drinking frequency to white matter integrity was strongly negative for women, but no relationship was observed for men. Variance accounted for in white matter integrity in women was $R^2 = .263$, compared to the overall $R^2 = .090$ for the model without the gender interaction. Other analyses suggested gender effects for problem severity and frequency of heavy drinking, yet not all components of those models reached significance. The main effect of gender, wherein women had lower FA values for the eight white matter ROIs, may be attributable to normal sex differences rather than alcohol-related damage. Therefore, the present findings do not show that women necessarily suffer a greater extent of alcohol-related white matter damage than men. Rather, the gender interaction suggests that mechanisms of alcohol-related white matter damage differ for men and women. One explanation for the significance of

drinking frequency for women but not men is that hormonal and metabolic factors cause women to “clear” the toxic byproducts of alcohol more slowly. Several lines of research, including animal models, have evinced greater alcohol neurotoxicity in females (Hashimoto & Wiren, 2008; Sharrett-Field, Butler, Reynolds, Berry, & Prendergast, 2013). Consequently, more frequent exposure to alcohol, and less time to repair alcohol-related damage, may be more harmful for women. These results contribute to a body of literature on sex differences in AUD consequences in which findings have been highly variable.

White matter integrity mediated the association between years of drinking and visuospatial ability, and this model was moderated by treatment-seeking status.

Variance accounted for in visuospatial scores was $R^2 = .175$. The interaction with treatment-seeking status warrants further investigation. One explanation is that treatment-seeking individuals manifested detrimental effects on cognitive functioning as a result of greater severity and heavier consumption. Alternatively, preexisting deficits in cognitive functioning may have conferred a vulnerability to heavy drinking. The main effect of treatment-seeking status, wherein the treatment-seeking group had lower FA values, may be due to greater severity, but age effects cannot be ruled out at present.

Comorbidity moderated the path from duration to frequency of drinking. It is often supposed that comorbidity presents a confound in studies comparing healthy and AUD groups. In particular, AUD individuals experience anxiety and depression at higher rates than the general population (Hasin, et al., 2007), and the neural phenotype associated with anxiety and depression appears to overlap considerably with brain differences linked to AUD diagnosis (Peterson & Weissman, 2011). The present study

used clinical cutoff values on anxiety and depression symptom questionnaires to dichotomize the sample into high and low comorbidity groups. No group difference was found on FA values of the eight white matter ROIs, even though the high comorbidity group reported heavier drinking and greater problem severity. As a moderator, comorbidity only affected the path from chronicity of drinking to frequency of drinking, with a linear, positive association for the low comorbidity group and no association for the high comorbidity group. This effect was not expected and could have arisen from chance variability in the sample. For the most part, relations of interest did not depend on comorbidity.

Smoking status was not a significant moderator. One important caveat to null findings is that participants were categorized as smokers if they reported any smoking in the past two to three months. This classification scheme may fail to capture the effects of regular, heavy smoking on white matter integrity. Infrequent or “social” smoking is regularly observed in studies of individuals with AUD, and no clear guidelines for classification exist. A more fine-grained analysis of the relation between smoking and white matter health could be a future direction.

Exploratory analysis. Evaluation of the contribution of white matter integrity to drinking intensity through subjective loss of control over drinking found preliminary support for this theoretical model. The model accounted for a non-trivial amount of variance in drinking outcome, with $R^2 = .254$. Deficits in self-regulation, especially in the ability to inhibit drug-seeking and use, are believed to be a core component in the development and maintenance of substance use disorders (Koob & Volkow, 2010).

Future research could explore the relation of white matter networks to behavioral control in AUD.

Future directions. This study made a novel application of SEM to variability in white matter integrity in the context of heavy drinking. Findings are suggestive of white matter vulnerability to specific aspects of drinking behavior, particularly in women. Research on functional ramifications of individual differences in white matter integrity is scarce at present. Results of this study are suggestive of unique, bidirectional relations between drinking behavior, individual differences, and white matter integrity. Although WMIF tracts were selected for their association with alcohol cue reactivity, these tracts subserve multiple, diverse functions in the brain. Tract-specific analyses guided by a priori knowledge of the functions of specific tracts may enhance precision of brain-behavior relationships. For example, the superior longitudinal fasciculus may be differentially important to cognitive functioning, whereas the cingulate may be preferentially associated with reward-seeking behavior. In addition, axial diffusivity and radial diffusivity are component metrics of FA that are believed to reflect axonal injury and dysmyelination, respectively. Analyzing these component metrics in a similar framework would be informative as to possible mechanisms of alcohol-related white matter variation. Finally, temporally lagged analyses on the relation between baseline white matter integrity and treatment outcome would support the validity of conclusions reached in this study and help to elucidate causal chains in the neurobiology of AUD.

References

- Abe, O., Aoki, S., Hayashi, N., Yamada, H., Kunimatsu, A., Mori, H., et al. (2002). Normal aging in the central nervous system: quantitative MR diffusion-tensor analysis. *Neurobiol Aging*, 23(3), 433-441.
- Agartz, I., Brag, S., Franck, J., Hammarberg, A., Okugawa, G., Svinhufvud, K., et al. (2003). MR volumetry during acute alcohol withdrawal and abstinence: a descriptive study. *Alcohol Alcohol*, 38(1), 71-78.
- Allen, J. P., & Litten, R. Z. (2001). The role of laboratory tests in alcoholism treatment. *J Subst Abuse Treat*, 20(1), 81-85.
- Babor, T. F., Higgins-Biddle, J. C., Saunders, J. B., & Monteiro, M. G. (2001). *The Alcohol Use Disorders Identification Test: Guidelines for Use in Primary Care* (2nd ed.): World Health Organization.
- Baraldi, A. N., & Enders, C. K. (2010). An introduction to modern missing data analyses. *J Sch Psychol*, 48(1), 5-37.
- Bartsch, A. J., Homola, G., Biller, A., Smith, S. M., Weijers, H. G., Wiesbeck, G. A., et al. (2007). Manifestations of early brain recovery associated with abstinence from alcoholism. *Brain*, 130(Pt 1), 36-47.
- Basser, P. J., & Pierpaoli, C. (1996). Microstructural and physiological features of tissues elucidated by quantitative-diffusion-tensor MRI. *J Magn Reson B*, 111(3), 209-219.
- Bava, S., Frank, L. R., McQueeney, T., Schweinsburg, B. C., Schweinsburg, A. D., & Tapert, S. F. (2009). Altered white matter microstructure in adolescent substance users. *Psychiatry Res*, 173(3), 228-237.

- Beaulieu, C. (2002). The basis of anisotropic water diffusion in the nervous system - a technical review. *NMR Biomed*, *15*(7-8), 435-455.
- Beck, A., & Steer, R. (1993). *Beck Anxiety Inventory Manual*. San Antonio, TX: The Psychological Corporation.
- Beck, A., Steer, R., & Brown, G. (1996). *Manual for the Beck Depression Inventory-II*. San Antonio, TX: Psychological Corporation.
- Bendlin, B. B., Fitzgerald, M. E., Ries, M. L., Xu, G., Kastman, E. K., Thiel, B. W., et al. (2010). White matter in aging and cognition: a cross-sectional study of microstructure in adults aged eighteen to eighty-three. *Dev Neuropsychol*, *35*(3), 257-277.
- Bennett, M. E., McCrady, B. S., Johnson, V., & Pandina, R. J. (1999). Problem drinking from young adulthood to adulthood: patterns, predictors and outcomes. *J Stud Alcohol*, *60*(5), 605-614.
- Brady, K. T., & Randall, C. L. (1999). Gender differences in substance use disorders. *Psychiatr Clin North Am*, *22*(2), 241-252.
- Brown, T. A. (2006). *Confirmatory Factor Analysis for Applied Research*. New York: Guilford Press.
- Cardenas, V. A., Studholme, C., Gazdzinski, S., Durazzo, T. C., & Meyerhoff, D. J. (2007). Deformation-based morphometry of brain changes in alcohol dependence and abstinence. *Neuroimage*, *34*(3), 879-887.
- Chen, C. H., Walker, J., Momenan, R., Rawlings, R., Heilig, M., & Hommer, D. W. (2012). Relationship between liver function and brain shrinkage in patients with alcohol dependence. *Alcohol Clin Exp Res*, *36*(4), 625-632.

- Chung, T., Pajtek, S., & Clark, D. B. (2012). White Matter Integrity as a Link in the Association Between Motivation to Abstain and Treatment Outcome in Adolescent Substance Users. *Psychol Addict Behav*.
- Cohen, E., Feinn, R., Arias, A., & Kranzler, H. R. (2007). Alcohol treatment utilization: findings from the National Epidemiologic Survey on Alcohol and Related Conditions. *Drug Alcohol Depend*, *86*(2-3), 214-221.
- Cohen, M. X., Heller, A. S., & Ranganath, C. (2005). Functional connectivity with anterior cingulate and orbitofrontal cortices during decision-making. *Brain Res Cogn Brain Res*, *23*(1), 61-70.
- Crews, F. T., & Nixon, K. (2009). Mechanisms of neurodegeneration and regeneration in alcoholism. *Alcohol Alcohol*, *44*(2), 115-127.
- de Bruin, E. A., Lemmens, P. H., Hulshoff Pol, H. E., Verbaten, M. N., & Kenemans, J. L. (2012). Relationship between carbohydrate-deficient transferrin, gamma-glutamyl transferase, and mean corpuscular volume levels and alcohol-related brain volume decreases in male drinkers. *Hum Psychopharmacol*, *27*(6), 559-565.
- Deichmann, R., Gottfried, J. A., Hutton, C., & Turner, R. (2003). Optimized EPI for fMRI studies of the orbitofrontal cortex. *Neuroimage*, *19*(2 Pt 1), 430-441.
- Drevets, W. C., Price, J. L., & Furey, M. L. (2008). Brain structural and functional abnormalities in mood disorders: implications for neurocircuitry models of depression. *Brain Struct Funct*, *213*(1-2), 93-118.
- Durazzo, T. C., Cardenas, V. A., Studholme, C., Weiner, M. W., & Meyerhoff, D. J. (2007). Non-treatment-seeking heavy drinkers: effects of chronic cigarette smoking on brain structure. *Drug Alcohol Depend*, *87*(1), 76-82.

- Durazzo, T. C., Gazdzinski, S., Banys, P., & Meyerhoff, D. J. (2004). Cigarette smoking exacerbates chronic alcohol-induced brain damage: a preliminary metabolite imaging study. *Alcohol Clin Exp Res*, 28(12), 1849-1860.
- Durazzo, T. C., Gazdzinski, S., Yeh, P. H., & Meyerhoff, D. J. (2008). Combined neuroimaging, neurocognitive and psychiatric factors to predict alcohol consumption following treatment for alcohol dependence. *Alcohol Alcohol*, 43(6), 683-691.
- Enders, B., & Tibshirani, R. (1993). *An introduction to the bootstrap*. New York: Chapman and Hall.
- Engvig, A., Fjell, A. M., Westlye, L. T., Moberget, T., Sundseth, Ø., Larsen, V. A., et al. (2010). Effects of memory training on cortical thickness in the elderly. *Neuroimage*, 52(4), 1667-1676.
- Fan, A. Z., Russell, M., Naimi, T., Li, Y., Liao, Y., Jiles, R., et al. (2008). Patterns of alcohol consumption and the metabolic syndrome. *J Clin Endocrinol Metab*, 93(10), 3833-3838.
- Fein, G., Bachman, L., Fisher, S., & Davenport, L. (1990). Cognitive impairments in abstinent alcoholics. *West J Med*, 152(5), 531-537.
- Fein, G., & Landman, B. (2005). Treated and treatment-naive alcoholics come from different populations. *Alcohol*, 36(2), 19-26.
- Fein, G., Torres, J., Price, L. J., & Di Sclafani, V. (2006). Cognitive performance in long-term abstinent alcoholic individuals. *Alcohol Clin Exp Res*, 30(9), 1538-1544.
- Fernández-Miranda, J. C., Rhoton, A. L., Alvarez-Linera, J., Kakizawa, Y., Choi, C., & de Oliveira, E. P. (2008). Three-dimensional microsurgical and tractographic

- anatomy of the white matter of the human brain. *Neurosurgery*, 62(6 Suppl 3), 989-1026; discussion 1026-1028.
- Fernández-Miranda, J. C., Rhoton, A. L., Kakizawa, Y., Choi, C., & Alvarez-Linera, J. (2008). The claustrum and its projection system in the human brain: a microsurgical and tractographic anatomical study. *J Neurosurg*, 108(4), 764-774.
- Filley, C. (2001). *The Behavioral Neurology of White Matter*. New York: Oxford University Press.
- Fjell, A. M., Westlye, L. T., Greve, D. N., Fischl, B., Benner, T., van der Kouwe, A. J., et al. (2008). The relationship between diffusion tensor imaging and volumetry as measures of white matter properties. *Neuroimage*, 42(4), 1654-1668.
- Fritz, M. S., & Mackinnon, D. P. (2007). Required sample size to detect the mediated effect. *Psychol Sci*, 18(3), 233-239.
- Fuchs, C. S., Stampfer, M. J., Colditz, G. A., Giovannucci, E. L., Manson, J. E., Kawachi, I., et al. (1995). Alcohol consumption and mortality among women. *N Engl J Med*, 332(19), 1245-1250.
- Garland, M. A., Parsons, O. A., & Nixon, S. J. (1993). Visual-spatial learning in nonalcoholic young adults with and those without a family history of alcoholism. *J Stud Alcohol*, 54(2), 219-224.
- Gazdzinski, S., Durazzo, T., Jahng, G. H., Ezekiel, F., Banys, P., & Meyerhoff, D. (2006). Effects of chronic alcohol dependence and chronic cigarette smoking on cerebral perfusion: a preliminary magnetic resonance study. *Alcohol Clin Exp Res*, 30(6), 947-958.

- Gazdzinski, S., Durazzo, T. C., & Meyerhoff, D. J. (2005). Temporal dynamics and determinants of whole brain tissue volume changes during recovery from alcohol dependence. *Drug Alcohol Depend*, 78(3), 263-273.
- Gazdzinski, S., Durazzo, T. C., Weiner, M. W., & Meyerhoff, D. J. (2008a). Are treated alcoholics representative of the entire population with alcohol use disorders? A magnetic resonance study of brain injury. *Alcohol*, 42(2), 67-76.
- Gazdzinski, S., Durazzo, T. C., Weiner, M. W., & Meyerhoff, D. J. (2008b). Are treated alcoholics representative of the entire population with alcohol use disorders? A magnetic resonance study of brain injury. *Alcohol*, 42(2), 67-76.
- Ge, Y., Grossman, R. I., Babb, J. S., Rabin, M. L., Mannon, L. J., & Kolson, D. L. (2002). Age-related total gray matter and white matter changes in normal adult brain. Part I: volumetric MR imaging analysis. *AJNR Am J Neuroradiol*, 23(8), 1327-1333.
- Giorgio, A., Santelli, L., Tomassini, V., Bosnell, R., Smith, S., De Stefano, N., et al. (2010). Age-related changes in grey and white matter structure throughout adulthood. *Neuroimage*, 51(3), 943-951.
- Grant, B. F., Dawson, D. A., Stinson, F. S., Chou, S. P., Dufour, M. C., & Pickering, R. P. (2004). The 12-month prevalence and trends in DSM-IV alcohol abuse and dependence: United States, 1991-1992 and 2001-2002. *Drug Alcohol Depend*, 74(3), 223-234.
- Grant, B. F., Hasin, D. S., Chou, S. P., Stinson, F. S., & Dawson, D. A. (2004). Nicotine dependence and psychiatric disorders in the United States: results from the national epidemiologic survey on alcohol and related conditions. *Arch Gen Psychiatry*, 61(11), 1107-1115.

- Grant, B. F., Stinson, F. S., Dawson, D. A., Chou, S. P., Dufour, M. C., Compton, W., et al. (2004). Prevalence and co-occurrence of substance use disorders and independent mood and anxiety disorders: results from the National Epidemiologic Survey on Alcohol and Related Conditions. *Arch Gen Psychiatry*, 61(8), 807-816.
- Harper, C., & Corbett, D. (1990). Changes in the basal dendrites of cortical pyramidal cells from alcoholic patients--a quantitative Golgi study. *J Neurol Neurosurg Psychiatry*, 53(10), 856-861.
- Harris, G. J., Jaffin, S. K., Hodge, S. M., Kennedy, D., Caviness, V. S., Marinkovic, K., et al. (2008). Frontal white matter and cingulum diffusion tensor imaging deficits in alcoholism. *Alcohol Clin Exp Res*, 32(6), 1001-1013.
- Harsan, L. A., Poulet, P., Guignard, B., Steibel, J., Parizel, N., de Sousa, P. L., et al. (2006). Brain dysmyelination and recovery assessment by noninvasive in vivo diffusion tensor magnetic resonance imaging. *J Neurosci Res*, 83(3), 392-402.
- Hashimoto, J. G., & Wiren, K. M. (2008). Neurotoxic consequences of chronic alcohol withdrawal: expression profiling reveals importance of gender over withdrawal severity. *Neuropsychopharmacology*, 33(5), 1084-1096.
- Hasin, D. S., Stinson, F. S., Ogburn, E., & Grant, B. F. (2007). Prevalence, correlates, disability, and comorbidity of DSM-IV alcohol abuse and dependence in the United States: results from the National Epidemiologic Survey on Alcohol and Related Conditions. *Arch Gen Psychiatry*, 64(7), 830-842.
- Heather, N., Tebbutt, J. S., Mattick, R. P., & Zamir, R. (1993). Development of a scale for measuring impaired control over alcohol consumption: a preliminary report. *J Stud Alcohol*, 54(6), 700-709.

- Hernandez-Avila, C. A., Rounsaville, B. J., & Kranzler, H. R. (2004). Opioid-, cannabis- and alcohol-dependent women show more rapid progression to substance abuse treatment. *Drug Alcohol Depend*, 74(3), 265-272.
- Herting, M. M., Schwartz, D., Mitchell, S. H., & Nagel, B. J. (2010). Delay discounting behavior and white matter microstructure abnormalities in youth with a family history of alcoholism. *Alcohol Clin Exp Res*, 34(9), 1590-1602.
- Hill, S. Y., Terwilliger, R., & McDermott, M. (2013). White matter microstructure, alcohol exposure, and familial risk for alcohol dependence. *Psychiatry Res*, 212(1), 43-53.
- Hofer, S., & Frahm, J. (2006). Topography of the human corpus callosum revisited--comprehensive fiber tractography using diffusion tensor magnetic resonance imaging. *Neuroimage*, 32(3), 989-994.
- Holroyd, C. B., & Yeung, N. (2012). Motivation of extended behaviors by anterior cingulate cortex. *Trends Cogn Sci*, 16(2), 122-128.
- Hommer, D., Momenan, R., Rawlings, R., Ragan, P., Williams, W., Rio, D., et al. (1996). Decreased corpus callosum size among alcoholic women. *Arch Neurol*, 53(4), 359-363.
- Hsu, J. L., Leemans, A., Bai, C. H., Lee, C. H., Tsai, Y. F., Chiu, H. C., et al. (2008). Gender differences and age-related white matter changes of the human brain: a diffusion tensor imaging study. *Neuroimage*, 39(2), 566-577.
- Inano, S., Takao, H., Hayashi, N., Abe, O., & Ohtomo, K. (2011). Effects of age and gender on white matter integrity. *AJNR Am J Neuroradiol*, 32(11), 2103-2109.

- Jackson, D. L., Gillaspay, J. A., & Purc-Stephenson, R. (2009). Reporting practices in confirmatory factor analysis: an overview and some recommendations. *Psychol Methods, 14*(1), 6-23.
- Jacobson, R. (1986). The contributions of sex and drinking history to the CT brain scan changes in alcoholics. *Psychol Med, 16*(3), 547-559.
- Jones, D. K., Horsfield, M. A., & Simmons, A. (1999). Optimal strategies for measuring diffusion in anisotropic systems by magnetic resonance imaging. *Magn Reson Med, 42*(3), 515-525.
- Kanaan, R. A., Allin, M., Picchioni, M., Barker, G. J., Daly, E., Shergill, S. S., et al. (2012). Gender differences in white matter microstructure. *PLoS One, 7*(6), e38272.
- Kandel, E., Schwartz, J., & Jessell, T. (2000). *Principles of Neural Science* (4th ed.): McGraw-Hill.
- Kang, X., Herron, T. J., & Woods, D. L. (2011). Regional variation, hemispheric asymmetries and gender differences in pericortical white matter. *Neuroimage, 56*(4), 2011-2023.
- Kantarci, K., Senjem, M. L., Avula, R., Zhang, B., Samikoglu, A. R., Weigand, S. D., et al. (2011). Diffusion tensor imaging and cognitive function in older adults with no dementia. *Neurology, 77*(1), 26-34.
- Kennedy, K. M., & Raz, N. (2009). Aging white matter and cognition: differential effects of regional variations in diffusion properties on memory, executive functions, and speed. *Neuropsychologia, 47*(3), 916-927.

- Keyes, K. M., Martins, S. S., Blanco, C., & Hasin, D. S. (2010). Telescoping and gender differences in alcohol dependence: new evidence from two national surveys. *Am J Psychiatry, 167*(8), 969-976.
- Koob, G. F. (2006). The neurobiology of addiction: a neuroadaptational view relevant for diagnosis. *Addiction, 101 Suppl 1*, 23-30.
- Koob, G. F., & Volkow, N. D. (2010). Neurocircuitry of addiction. *Neuropsychopharmacology, 35*(1), 217-238.
- Kril, J. J., & Halliday, G. M. (1999). Brain shrinkage in alcoholics: a decade on and what have we learned? *Prog Neurobiol, 58*(4), 381-387.
- Lewohl, J. M., Wang, L., Miles, M. F., Zhang, L., Dodd, P. R., & Harris, R. A. (2000). Gene expression in human alcoholism: microarray analysis of frontal cortex. *Alcohol Clin Exp Res, 24*(12), 1873-1882.
- Lezak, M., Howieson, D., & Loring, D. (2004). *Neuropsychological Assessment*. Oxford: Oxford University Press.
- Liu, J., Lewohl, J. M., Harris, R. A., Dodd, P. R., & Mayfield, R. D. (2007). Altered gene expression profiles in the frontal cortex of cirrhotic alcoholics. *Alcohol Clin Exp Res, 31*(9), 1460-1466.
- Lloyd, J. J., Chen, C. Y., Storr, C. L., & Anthony, J. C. (2004). Clinical features associated with receipt of alcohol treatment. *J Stud Alcohol, 65*(6), 750-757.
- MacCallum, R. C., & Austin, J. T. (2000). Applications of structural equation modeling in psychological research. *Annu Rev Psychol, 51*, 201-226.
- MacKinnon, D. P. (2008). *Introduction to Statistical Mediation Analysis*. New York: Lawrence Erlbaum Associates.

- Madden, D. J., Spaniol, J., Costello, M. C., Bucur, B., White, L. E., Cabeza, R., et al. (2009). Cerebral white matter integrity mediates adult age differences in cognitive performance. *J Cogn Neurosci*, *21*(2), 289-302.
- Makris, N., Buka, S. L., Biederman, J., Papadimitriou, G. M., Hodge, S. M., Valera, E. M., et al. (2008). Attention and executive systems abnormalities in adults with childhood ADHD: A DT-MRI study of connections. *Cereb Cortex*, *18*(5), 1210-1220.
- Mann, K., Ackermann, K., Croissant, B., Mundle, G., Nakovics, H., & Diehl, A. (2005). Neuroimaging of gender differences in alcohol dependence: are women more vulnerable? *Alcohol Clin Exp Res*, *29*(5), 896-901.
- Mann, K., Batra, A., Günthner, A., & Schroth, G. (1992). Do women develop alcoholic brain damage more readily than men? *Alcohol Clin Exp Res*, *16*(6), 1052-1056.
- Molina, B. S., Hinshaw, S. P., Eugene Arnold, L., Swanson, J. M., Pelham, W. E., Hechtman, L., et al. (2013). Adolescent substance use in the multimodal treatment study of Attention-Deficit/Hyperactivity Disorder (ADHD) (MTA) as a function of childhood ADHD, random assignment to childhood treatments, and subsequent medication. *J Am Acad Child Adolesc Psychiatry*, *52*(3), 250-263.
- Molina, J. A., Bermejo, F., del Ser, T., Jiménez-Jiménez, F. J., Herranz, A., Fernández-Calle, P., et al. (1994). Alcoholic cognitive deterioration and nutritional deficiencies. *Acta Neurol Scand*, *89*(5), 384-390.
- Monnig, M. A., Caprihan, A., Yeo, R. A., Gasparovic, C., Ruhl, D. A., Lysne, P., et al. (2012). Diffusion Tensor Imaging of White Matter Networks in Individuals With

Current and Remitted Alcohol Use Disorders and Comorbid Conditions. *Psychol Addict Behav*.

Monnig, M. A., Thayer, R. E., Caprihan, A., Claus, E. D., Yeo, R. A., Calhoun, V. D., et al. (under review). White matter integrity is associated with alcohol cue reactivity in heavy drinkers. *Brain and Behavior*.

Monnig, M. A., Tonigan, J. S., Yeo, R. A., Thoma, R. J., & McCrady, B. S. (2012). White matter volume in alcohol use disorders: a meta-analysis. *Addict Biol*.

Mori, S., Wakana, S., Nagae-Poetscher, L. M., & van Zijl, P. C. M. (2005). *MRI Atlas of Human White Matter*. Amsterdam: Elsevier Science.

Moselhy, H. F., Georgiou, G., & Kahn, A. (2001). Frontal lobe changes in alcoholism: a review of the literature. *Alcohol Alcohol*, 36(5), 357-368.

Muthen, B. O. (2011). Applications of causally defined direct and indirect effects in mediation analysis using SEM in Mplus. Retrieved 5/1/2013, from <http://www.statmodel.com/download/causalmediation.pdf>

Muthen, L. K., & Muthen, B. O. (1998-2012). *Mplus User's Guide: Statistical Analysis with Latent Variables* (7th edition ed.). Los Angeles, CA: Muthen & Muthen.

Muthen, L. K., & Muthen, B. O. (November, 2011). Indirect effect insignificant while both paths significant. Retrieved 5/1/2013, from <http://www.statmodel.com/faq.shtml>

Muuronen, A., Bergman, H., Hindmarsh, T., & Telakivi, T. (1989). Influence of improved drinking habits on brain atrophy and cognitive performance in alcoholic patients: a 5-year follow-up study. *Alcohol Clin Exp Res*, 13(1), 137-141.

- Nolen-Hoeksema, S. (2004). Gender differences in risk factors and consequences for alcohol use and problems. *Clin Psychol Rev*, 24(8), 981-1010.
- Oscar-Berman, M., & Marinković, K. (2007). Alcohol: effects on neurobehavioral functions and the brain. *Neuropsychol Rev*, 17(3), 239-257.
- Penke, L., Maniega, S. M., Bastin, M. E., Valdés Hernández, M. C., Murray, C., Royle, N. A., et al. (2012). Brain white matter tract integrity as a neural foundation for general intelligence. *Mol Psychiatry*, 17(10), 1026-1030.
- Peterson, B. S., & Weissman, M. M. (2011). A brain-based endophenotype for major depressive disorder. *Annual Review of Medicine*, 62(461-74).
- Pfefferbaum, A., Adalsteinsson, E., & Sullivan, E. V. (2006). Dymorphology and microstructural degradation of the corpus callosum: Interaction of age and alcoholism. *Neurobiol Aging*, 27(7), 994-1009.
- Pfefferbaum, A., Rosenbloom, M., Rohlfing, T., & Sullivan, E. V. (2009). Degradation of association and projection white matter systems in alcoholism detected with quantitative fiber tracking. *Biol Psychiatry*, 65(8), 680-690.
- Pfefferbaum, A., Sullivan, E. V., Hedehus, M., Adalsteinsson, E., Lim, K. O., & Moseley, M. (2000). In vivo detection and functional correlates of white matter microstructural disruption in chronic alcoholism. *Alcohol Clin Exp Res*, 24(8), 1214-1221.
- Pfefferbaum, A., Sullivan, E. V., Mathalon, D. H., Shear, P. K., Rosenbloom, M. J., & Lim, K. O. (1995). Longitudinal changes in magnetic resonance imaging brain volumes in abstinent and relapsed alcoholics. *Alcohol Clin Exp Res*, 19(5), 1177-1191.

- Pfefferbaum, A., Sullivan, E. V., Rosenbloom, M. J., Mathalon, D. H., & Lim, K. O. (1998). A controlled study of cortical gray matter and ventricular changes in alcoholic men over a 5-year interval. *Arch Gen Psychiatry*, *55*(10), 905-912.
- Pierpaoli, C., Barnett, A., Pajevic, S., Chen, R., Penix, L. R., Virta, A., et al. (2001). Water diffusion changes in Wallerian degeneration and their dependence on white matter architecture. *Neuroimage*, *13*(6 Pt 1), 1174-1185.
- Preacher, K., Rucker, D., & Hayes, A. (2007). Addressing moderated mediation hypotheses: Theory, methods, and prescriptions. *Multivariate Behavioral Research*, *42*(1), 185-227.
- Preacher, K. J., & Hayes, A. F. (2008). Asymptotic and resampling strategies for assessing and comparing indirect effects in multiple mediator models. *Behav Res Methods*, *40*(3), 879-891.
- Psychological Corporation. (1999). *Wechsler Abbreviated Scale of Intelligence (WASI) manual*. San Antonio, TX.
- Randall, C. L., Roberts, J. S., Del Boca, F. K., Carroll, K. M., Connors, G. J., & Mattson, M. E. (1999). Telescoping of landmark events associated with drinking: A gender comparison. *Journal of Studies on Alcohol*, *60*(2), 252-260.
- Rogers, R. D., Ramnani, N., Mackay, C., Wilson, J. L., Jezzard, P., Carter, C. S., et al. (2004). Distinct portions of anterior cingulate cortex and medial prefrontal cortex are activated by reward processing in separable phases of decision-making cognition. *Biol Psychiatry*, *55*(6), 594-602.

- Rohlfing, T., Sullivan, E. V., & Pfefferbaum, A. (2006). Deformation-based brain morphometry to track the course of alcoholism: differences between intra-subject and inter-subject analysis. *Psychiatry Res, 146*(2), 157-170.
- Rucker, D., Preacher, K., Tormala, Z., & Petty, R. (2011). Mediation analysis in social psychology: Current practices and new recommendations. *Social and Personality Psychology Compass, 5/6*, 359-371.
- Salami, A., Eriksson, J., Nilsson, L. G., & Nyberg, L. (2012). Age-related white matter microstructural differences partly mediate age-related decline in processing speed but not cognition. *Biochim Biophys Acta, 1822*(3), 408-415.
- Sasson, E., Doniger, G. M., Pasternak, O., Tarrasch, R., & Assaf, Y. (2013). White matter correlates of cognitive domains in normal aging with diffusion tensor imaging. *Front Neurosci, 7*, 32.
- Saunders, J. B., Davis, M., & Williams, R. (1981). Do women develop alcoholic liver disease more readily than men? *Br Med J (Clin Res Ed), 282*(6270), 1140-1143.
- Schmahmann, J. D., Smith, E. E., Eichler, F. S., & Filley, C. M. (2008). Cerebral white matter: neuroanatomy, clinical neurology, and neurobehavioral correlates. *Ann N Y Acad Sci, 1142*, 266-309.
- Schuckit, M. A., Daepfen, J. B., Tipp, J. E., Hesselbrock, M., & Bucholz, K. K. (1998). The clinical course of alcohol-related problems in alcohol dependent and nonalcohol dependent drinking women and men. *J Stud Alcohol, 59*(5), 581-590.
- Sharrett-Field, L., Butler, T. R., Reynolds, A. R., Berry, J. N., & Prendergast, M. A. (2013). Sex differences in neuroadaptation to alcohol and withdrawal neurotoxicity. *Pflugers Arch*.

- Shear, P. K., Jernigan, T. L., & Butters, N. (1994). Volumetric magnetic resonance imaging quantification of longitudinal brain changes in abstinent alcoholics. *Alcohol Clin Exp Res, 18*(1), 172-176.
- Skinner, H. A., & Horn, J. L. (1984). *Alcohol Dependence Scale: Users Guide*. Toronto: Addiction Research Foundation.
- Smith, S., & Fein, G. (2010). Cognitive performance in treatment-naïve active alcoholics. *Alcohol Clin Exp Res, 34*(12), 2097-2105.
- Smith, S. M., Jenkinson, M., Johansen-Berg, H., Rueckert, D., Nichols, T. E., Mackay, C. E., et al. (2006). Tract-based spatial statistics: voxelwise analysis of multi-subject diffusion data. *Neuroimage, 31*(4), 1487-1505.
- Sobell, L. C., & Sobell, M. B. (1992). Timeline Followback: A technique for assessing self-reported alcohol consumption. In J. P. Allen & M. Columbus (Eds.), *Assessing Alcohol Problems: A Guide for Clinicians and Researchers* (pp. 55-73). Bethesda, MD: National Institute on Alcohol Abuse and Alcoholism.
- Song, S. K., Sun, S. W., Ju, W. K., Lin, S. J., Cross, A. H., & Neufeld, A. H. (2003). Diffusion tensor imaging detects and differentiates axon and myelin degeneration in mouse optic nerve after retinal ischemia. *Neuroimage, 20*(3), 1714-1722.
- Song, S. K., Sun, S. W., Ramsbottom, M. J., Chang, C., Russell, J., & Cross, A. H. (2002). Dysmyelination revealed through MRI as increased radial (but unchanged axial) diffusion of water. *Neuroimage, 17*(3), 1429-1436.
- Song, S. K., Yoshino, J., Le, T. Q., Lin, S. J., Sun, S. W., Cross, A. H., et al. (2005). Demyelination increases radial diffusivity in corpus callosum of mouse brain. *Neuroimage, 26*(1), 132-140.

- Sorg, S. F., Taylor, M. J., Alhassoon, O. M., Gongvatana, A., Theilmann, R. J., Frank, L. R., et al. (2012). Frontal white matter integrity predictors of adult alcohol treatment outcome. *Biol Psychiatry*, *71*(3), 262-268.
- Sullivan, E. V. (2000). *Human brain vulnerability to alcoholism: Evidence from neuroimaging studies*.
- Sullivan, E. V., & Pfefferbaum, A. (2005). Neurocircuitry in alcoholism: a substrate of disruption and repair. *Psychopharmacology (Berl)*, *180*(4), 583-594.
- Sullivan, E. V., Rohlfing, T., & Pfefferbaum, A. (2010). Pontocerebellar volume deficits and ataxia in alcoholic men and women: no evidence for “telescoping”. *Psychopharmacology (Berl)*, *208*(2), 279-290.
- Sullivan, E. V., Rosenbloom, M. J., Lim, K. O., & Pfefferbaum, A. (2000). Longitudinal changes in cognition, gait, and balance in abstinent and relapsed alcoholic men: relationships to changes in brain structure. *Neuropsychology*, *14*(2), 178-188.
- Sullivan, J. T., Sykora, K., Schneiderman, J., Naranjo, C. A., & Sellers, E. M. (1989). Assessment of alcohol withdrawal: the revised clinical institute withdrawal assessment for alcohol scale (CIWA-Ar). *Br J Addict*, *84*(11), 1353-1357.
- Swan, G. E., & Lessov-Schlaggar, C. N. (2007). The effects of tobacco smoke and nicotine on cognition and the brain. *Neuropsychol Rev*, *17*(3), 259-273.
- Tham, M. W., Woon, P. S., Sum, M. Y., Lee, T. S., & Sim, K. (2010). White matter abnormalities in major depression: Evidence from post-mortem, neuroimaging and genetic studies. *Journal of Affective Disorders*, *E-pub ahead of print*.

- Thoma, R. J., Monnig, M. A., Lysne, P. A., Ruhl, D. A., Pommy, J. A., Bogenschutz, M., et al. (2011). Adolescent substance abuse: the effects of alcohol and marijuana on neuropsychological performance. *Alcohol Clin Exp Res*, 35(1), 39-46.
- van Norden, A. G., de Laat, K. F., Fick, I., van Uden, I. W., van Oudheusden, L. J., Gons, R. A., et al. (2011). Diffusion tensor imaging of the hippocampus and verbal memory performance: The RUN DMC Study. *Hum Brain Mapp*.
- van Tol, M. J., van der Wee, N. J., van den Heuvel, O. A., Nielen, M. M., Demenescu, L. R., Aleman, A., et al. (2010). Regional brain volume in depression and anxiety disorders. *Arch Gen Psychiatry*, 67(10), 1002-1011.
- Wakana, S., Caprihan, A., Panzenboeck, M. M., Fallon, J. H., Perry, M., Gollub, R. L., et al. (2007). Reproducibility of quantitative tractography methods applied to cerebral white matter. *Neuroimage*, 36(3), 630-644.
- Walhovd, K. B., Fjell, A. M., Reinvang, I., Lundervold, A., Dale, A. M., Eilertsen, D. E., et al. (2005). Effects of age on volumes of cortex, white matter and subcortical structures. *Neurobiol Aging*, 26(9), 1261-1270; discussion 1275-1268.
- Yeh, P. H., Simpson, K., Durazzo, T. C., Gazdzinski, S., & Meyerhoff, D. J. (2009). Tract-Based Spatial Statistics (TBSS) of diffusion tensor imaging data in alcohol dependence: abnormalities of the motivational neurocircuitry. *Psychiatry Res*, 173(1), 22-30.
- Ystad, M., Hodneland, E., Adolfsdottir, S., Haász, J., Lundervold, A. J., Eichele, T., et al. (2011). Cortico-striatal connectivity and cognition in normal aging: a combined DTI and resting state fMRI study. *Neuroimage*, 55(1), 24-31.

Zhuang, L., Sachdev, P. S., Trollor, J. N., Kochan, N. A., Reppermund, S., Brodaty, H., et al. (2012). Microstructural white matter changes in cognitively normal individuals at risk of amnesic MCI. *Neurology*, *79*(8), 748-754.

Ziegler, D. A., Piguet, O., Salat, D. H., Prince, K., Connally, E., & Corkin, S. (2010). Cognition in healthy aging is related to regional white matter integrity, but not cortical thickness. *Neurobiol Aging*, *31*(11), 1912-1926.