

7-1-2011

An agent based framework for sharing personal health information

Ravi Kiran Kadaboina

Follow this and additional works at: https://digitalrepository.unm.edu/ece_etds

Recommended Citation

Kadaboina, Ravi Kiran. "An agent based framework for sharing personal health information." (2011).
https://digitalrepository.unm.edu/ece_etds/130

This Thesis is brought to you for free and open access by the Engineering ETDs at UNM Digital Repository. It has been accepted for inclusion in Electrical and Computer Engineering ETDs by an authorized administrator of UNM Digital Repository. For more information, please contact disc@unm.edu.

Ravi Kiran Kadaboina

Candidate

Electrical & Computer Engineering

Department

This thesis is approved, and it is acceptable in quality and form for publication:

Approved by the Thesis Committee:

Dr. Gregory L. Heileman

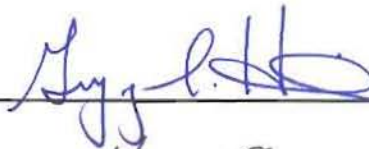

Chairperson

Dr. Nasir Ghani



Dr. Edward D. Graham, Jr.

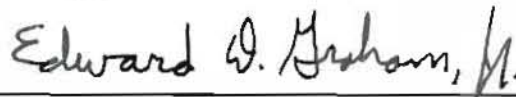

**AN AGENT BASED FRAMEWORK FOR
SHARING PERSONAL HEALTH INFORMATION**

BY

RAVI KIRAN KADABOINA

**BACHELOR OF TECHNOLOGY IN ELECTRONICS AND
COMMUNICATIONS ENGINEERING
2007**

THESIS

Submitted in Partial Fulfillment of the
Requirements for the Degree of

**Master of Science
Computer Engineering**

The University of New Mexico
Albuquerque, New Mexico

May 2011

ACKNOWLEDGEMENT

Firstly, I am very much indebted to my advisor Dr. Gregory L. Heileman for providing me with motivation and encouragement throughout the course of my work. His breadth of knowledge and enthusiasm has been invaluable. Without his supervision and constant knowledge inputs, I would not be able to complete my thesis.

I would also like to thank Pramod Jamkhedkar, Chris Lamb and Viswanath Nandina for their valuable suggestions and for the many intuitive discussions we had in our research group meetings.

Many thanks also go to other faculty members especially Dr. Nasir Ghani and Dr. Edward D. Graham, Jr. for their support and my colleagues Dennis Magee Jr. and Frank Mercer and supervisor Robert Nocella at Computer Support Group for making my presence at UNM a memorable one.

Finally, I am indebted to my parents for their affection and encouragement to pursue a Master's degree.

**AN AGENT BASED FRAMEWORK FOR
SHARING PERSONAL HEALTH INFORMATION**

BY

RAVI KIRAN KADABOINA

ABSTRACT OF THESIS

Submitted in Partial Fulfillment of the
Requirements for the Degree of

**Master of Science
Computer Engineering**

The University of New Mexico
Albuquerque, New Mexico

May 2011

AN AGENT BASED FRAMEWORK FOR SHARING PERSONAL HEALTH INFORMATION

By

Ravi Kiran Kadaboina

B.Tech., Jawaharlal Nehru Technological University, 2007

M.S., Computer Engineering, University of New Mexico 2011

ABSTRACT

Over the past few years, several commercial vendors have started providing Personal Health Record (PHR) services. The PHR has been developed to be consumer-centric such that the consumer has all the control and not the health care provider. PHRs can be created, accessed and shared by a patient with authorized persons with the help of Health cloud based services provided by vendors like Microsoft HealthVault and Google Health. However, there is no formalized semantics that encourage users to share their data with prospective research facilities and drug companies. Creating an environment that allows users to manage how their personal health information is used will encourage them to share data that will improve the way healthcare is delivered due to the many advantages of secondary usage of data. This thesis presents a proof of concept with the implementation of an agent based framework that allows users to negotiate and trade medical data by the application of usage management of records and payment schemes.

TABLE OF CONTENTS

LIST OF FIGURES	viii
LIST OF TABLES	x
LIST OF ABBREVIATION AND ACRONYMS	xi
1 Introduction.....	1
1.1 Background.....	1
1.1.1 Personal Health Record (PHR)	1
1.1.2 The ASTM CCR Standard	2
1.1.3 Health Level Seven (HL7) Standards.	3
1.1.4 Continuity of Care Document (CCD)	4
1.1.5 Health Cloud Services.....	4
1.2 Motivation.....	6
1.3 Related Work	8
1.4 Our Approach.....	8
2 Architecture of the MedTrading system	11
2.1 System Overview	11
2.2 Components	12
2.2.1 Source: CCR document.....	12
2.2.2 Unmarshalling XML document to Content Objects.	15
2.2.3 Health Vocabularies and Coding Systems.	16

2.2.4 Java Agent DEvelopment Framework (JADE).....	20
2.2.4.1 JADE Architecture.....	21
2.2.4.2 FIPA standards.....	22
2.2.4.3 FIPA Communicative Acts	24
2.2.4.4 FIPA Interaction Protocols.....	25
3 Implementation	27
3.1 Application Development	27
3.1.1 CCR Downloader Application.....	27
3.1.2 The MedTrading exchange server application.....	27
3.2 Agents Development.....	28
4 The framework in Action.....	32
4.1 The CCR Downloader Application.....	32
4.2 MedTrading Exchange Server in Action	34
5 Conclusions and Future Work	40
6 References.....	41

LIST OF FIGURES

Figure 1: CCR elements.....	3
Figure 2: The MedTrading Server Model.....	9
Figure 3: System Overview	11
Figure 4: Use Case Diagram.....	12
Figure 5: AuthSub Protocol	14
Figure 6: OAuth Protocol.....	14
Figure 7: Sample CCR.....	15
Figure 8: JAXB API.....	16
Figure 9: SNOMED CT CORE Problem List Subset	18
Figure 10: JADE Architecture	22
Figure 11: FIPA specifications classifications [Source: www.fipa.org].....	23
Figure 12: A sample FIPA-ACL message with cfp performative.....	26
Figure 13: FIPA Contract Net Interaction Protocol.....	26
Figure 14: Deployment Diagram	28
Figure 15: Sample DF agent registration	29
Figure 16: Sequence Diagram of Buyer.....	31
Figure 17: User is redirected to H9 Sandbox where authentication is done	32
Figure 18: User authorizes the application access to the profile.....	33
Figure 19: Google Health Web Interface to enter Health Information	34
Figure 20: Login Page.....	35
Figure 21: User choice selection.....	35
Figure 22: Buyer Interface.....	36
Figure 23: Seller Interface	37

Figure 24: A sample of the terms file	37
Figure 25: Console output.....	38
Figure 26: Conversation Visualization with the help of Sniffer Agent	39

LIST OF TABLES

Table 1: FIPA ACL message parameters	23
Table 2: FIPA Communicative Act Library	25

LIST OF ABBREVIATION AND ACRONYMS

PHR	Personal Health Record
EHR	Electronic Health Record
EMR	Electronic Medical Record
ASTM	American Society for Testing and Materials
CCR	Continuity of Care Record
XML	Extensible Markup Language
HL7	Health Level Seven
CDA	Clinical Document Architecture
MIME	Multipurpose Internet Mail Extensions
CCD	Continuity of Care Document
CEO	Chief Executive Officer
IT	Information Technology
CRUD	Create, Read, Update and Delete
PCHR	Personally Controlled Health Records
JADE	Java Agent DEvelopment Framework
FIPA	Foundation for Intelligent Physical Agents
HIE	Health Information Exchange
API	Application Programming Interface
URL	Uniform Resource Locator
JAXB	Java Architecture for XML Binding

NDC	National Drug Code
FDB	Food and Drugs Board
SNOMED CT	Systematized Nomenclature of Medicine – Clinical Terms
ICD9	International Statistical Classification of Diseases and Related Health Problems
CPT	Current Procedural Terminology
LOINC	Logical Observation Identifiers Names and Codes
NLM	United States National Library of Medicine
IHTSDO	International Health Terminology Standards Development Organisation
FSN	Fully Specified Name
UMLS	Unified Medical Language System
MAS	Multi-Agent System
AMS	Agent Management System
DF	Directory Facilitator
ACL	Agent Communication Language
UMHR	Usage Managed Health Record

1 Introduction

In this section we discuss the motivation leading to our work, an overview of related work done in the area of sharing of personal health information and describe the problems associated with current Personal Health Record systems. Finally we state our goals towards the research. Section 1.1 gives an introduction to PHR and other standards in the medical industry as well as some of the services provided by vendors providing PHR systems. Section 1.2 describes the motivation upon which the thesis was developed. Section 1.3 discusses about current research related to sharing of medical information. Section 1.4 describes the specific goals of the research and our approach in building those goals.

1.1 Background

1.1.1 Personal Health Record (PHR)

Though the term “personal health record” was coined back in 1978, the definition of PHR has been constantly evolving with respect to technological advancements. Earlier it meant to be both paper-based and computer-based but with recent advancements in the way people view and use data with computers has resulted in the PHR being mainly an electronic resource which is much more portable and enables development of useful mobile and web applications. People have long been keeping some sort of paper copies or empty strips or bottles of used medicines for either record keeping or future access to health care services but this has resulted in the patient not having accurate information due to losing some piece of that copy or due to not sorting information chronologically.

So a PHR system is one that stores and provides a summary of the health and medical history of an individual by gathering data from many sources including physicians, pharmacists and the user itself and enables the involved entities to view the data on demand. As the author in [1] observes, the great potential of electronic PHRs was not realized until recently when patients living in areas affected by Hurricanes Katrina and Rita who did not even have basic information about their health, such as their medications and dosages, due to the devastation of their homes that had all their paper records. Today, PHR systems have evolved a long way which allows the users to do a lot of functions and involve multiple stakeholders into the scenario to enable the full potential of the health services.

1.1.2 The ASTM CCR Standard

During the design of a format for PHR, many considerations were taken into account such as portability, interoperability and to be expressed as an electronic file that provides the summary of patient health information and that can be created, read and interpreted by any EHR or EMR software systems. Thus the ASTM Continuity of Care Record (CCR) standard was developed and chosen by many vendors as it is expressed in the standard data interchange language XML which makes it very easy due to its ability to be machine readable.

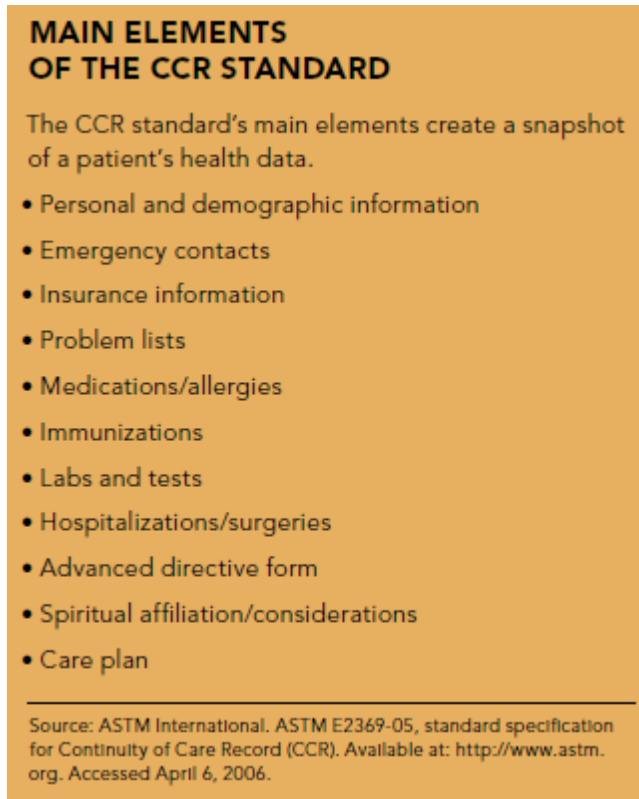

Figure 1: CCR elements

A CCR provides a snapshot of a patient's relevant medical information at a specific moment in time such as summary of previous problems history, allergies, current medication, dosages and recent test results [2]. Though it does not provide all the detailed information such as physician's notes, scanned images and videos, the information CCR carries is quite useful in determining the patient's previous treatment and current conditions, eventually expediting the care for the patient.

1.1.3 Health Level Seven (HL7) Standards.

HL7 standards are the mostly widely accepted standards for exchange, integration, sharing, and retrieval of electronic health information in healthcare organizations such as hospitals, insurance companies and others. The HL7 messaging and Clinical Document Architecture (CDA) are standards that fill the gap between legacy

Electronic Health Record systems and Health Information Exchanges spread across the nation with interoperability frameworks. CDA is an XML-based markup standard intended to specify the encoding, structure and semantics of clinical documents for exchange and includes comprehensive information such as discharge summaries, progress notes and reports including standard MIME types. Clearly it will be very beneficial if conventional Electronic Health Systems at hospitals and healthcare organizations be able to use a CCR and be able to map to the CDA elements, the output of such an effort is the Continuity of Care Document (CCD).

1.1.4 Continuity of Care Document (CCD)

HL7 and ASTM International jointly created the Continuity of Care Document (CCD) to integrate the ASTM's CCR with the HL7's Clinical Document architecture as HL7 standard was adopted as a U.S. government standard for Electronic Health Records. As Peter Waegemann, CEO of Medical Records Institute describes that "Vendors and users of large IT legacy systems that are backers of HL7's CDA will gain the most benefit from the CCD because they will be able to use the CCR format in their systems and that the collaboration with HL7 on the CCD further establishes the CCR." [6]. The CCD is built upon CDA elements, but the data itself is defined by CCR and provides an overall summary of a patient's care which, when combined together with other CCDs, can form an aggregate record.

1.1.5 Health Cloud Services

- **Microsoft HealthVault** Microsoft HealthVault is an online PHR system that "offers a central repository for health information that people gather

from across the spectrum of healthcare” (Microsoft, 2010). HealthVault has already a very good number of HealthCare partners including device manufacturers and has a plethora of applications that the users can use to manage their health online. HealthVault has a very strong ecosystem of employers, healthcare associations, laboratories and imaging centers, hospitals, physicians and pharmacies. Patients can upload their medical device readings directly into their HealthVault record and the assigned providers can monitor the data and be able to provide custom care to their patients. It supports both ASTM CCR and CCD formats. Users can share data either with authorized family members, a physician or an application. The user can select Create, Read, Update and Delete (CRUD) Operations for the person for each data type available along with an expiration date on the shared access.

- **Google Health** Google Health is another personal health information centralization service developed by Google Inc. Similarly to Microsoft, Google provides an easy access to personal health information online. Users can store, manage and share all of their health and wellness information from one central location. Users can import health data directly from patient approved doctors, hospitals and pharmacies. Google Health supports a subset of the CCR format.

1.2 Motivation

Secondary Usage of Health Data

With the availability of the above PHR systems, the aggregate amount of data generated for each patient is going to increase many fold. This data can be very valuable over the long run to many entities that involve the need of patient data. Farther, it is the information collected over the years that can be used to identify disease mutations and drug resistance anomalies. This term secondary usage of data means all that usage of personal health information not for the direct care of the patient but for other purposes such as research and development, public health, drug safety surveillance, insurance and marketing purposes that can improve the delivery of Healthcare for everyone. The most impact that the secondary usage of data could have is to bring down the amount of time it takes to release a single drug. Considering the actual cost for discovering, developing and launching a single new drug which is estimated to be about \$1.7 billion and that it could rise to many fold in the coming years [3] with the current methods employed such as inputs only from physicians and pre-clinical trials for the release of a drug. Secondary usage of data can thus reduce this cost very effectively. During the FDA approved pre-marketing testing phases, adverse drug experience studies are limited due to the fact that age, sex, past medical history, and drug interactions are not necessarily available or taken into consideration. Even in post-marketing testing phase adverse drug experiences are submitted only voluntarily, which do not include the whole population of users [4]. Thus, commercialization of secondary usage of anonymized data will help to identify health problems associated with drug reactions and to evaluate of the effectiveness of treatments and tests done. So from a commercial viewpoint, companies will benefit considerably

from collecting healthcare data by reducing the time to succeed in a marketing surveillance, this increases profits and also helps to sell products and services based upon these data to a variety of consumers including third party payers, researchers, and marketing related entities. Whereas from the patient viewpoint, the patient will be able to earn some incentives either in the form of monetary funds or drug samples.

Key findings that encouraged this research

During a study conducted to characterize consumer willingness to share PHR data for health research found some key conditions were found wherein consumers are more interested in sharing data. Ninety-one percent of users favored an opt-in sharing model specified the following conditions [5].

1. Anonymity
2. research use
3. engagement only with a trusted intermediary
4. transparency around PCHR access and use
5. Payment

The full potential of PHRs can be best realized if secondary usage of data is made available at the discretion of the user while also safeguarding his privacy. Users should be given a choice regarding the utilization of their data. This was the main objective with which we have proceeded in the research described. The core of this output was the MedTrading agent based system that handles all these conditions thus making the user more powerful participant with the transformation of an ordinary PHR into a Usage Managed Health Record (UMHR).

1.3 Related Work

The increase in the adoption of EHR systems in hospitals and healthcare organizations and availability of PHR services to the users has resulted in a significant growth in the amount of health data available for secondary uses. De-identified health data is already used for health research and commercial purposes. For example, pharmaceutical companies use this data to characterize population learning about drug usage and the risks of these drugs in order to improve the efficiency of sales [7]. There are many stakeholders involved in the usage of secondary data and business models developed to tap revenue form their usage. There are many questions raised about the usage of these data as well as of these data who receives the payments [8]. But we firmly believe that there may be many entities that own at least a part of data but, ultimately, the prime source is the patient. The patient needs to be compensated for any revenue made from the selling of such medical data.

1.4 Our Approach

We approach the problem by creating a user controlled opt-in/opt-out sharing model. Anonymity is provided through sharing at data type level. The application of usage terms over the records transforms the CCR into a UMHR. We introduce payment mechanisms to encourage users in sharing data and adopt the model easily. The architecture of our framework incorporates ASTM CCR schema plus actual CCR documents of test users from Microsoft HealthVault and Google Health. We have taken the software agents approach to provide users with automatic negotiations. The main broker application at the front end extracts the data provided by the user and makes it available to the software agents. Each user has a dedicated agent. The software agents

then exchange information and update the accounts of the respective users with payment being either credited or debited.

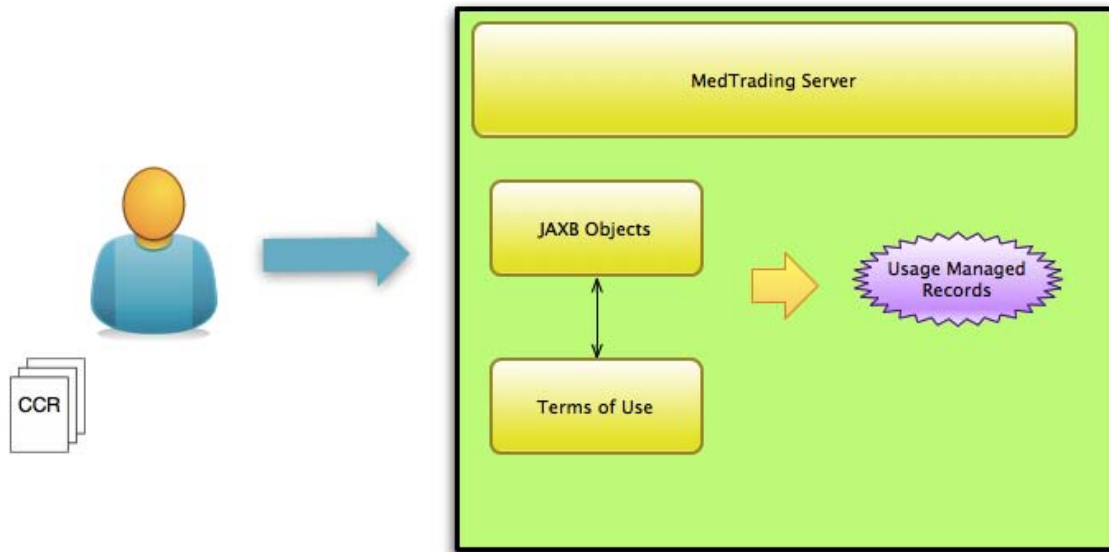

Figure 2: The MedTrading Server Model

Why Artificial Agents?

The emergence of a variety of e-commerce activities over the last decade has initiated new opportunities for businesses around the globe. Also new insights have been gained as to how intelligent software agents might be used in these volatile markets. Businesses revolve around online exchange of information, services and products and decisions have to be taken at every step. Depending solely on human decisions is quite impossible, thus the use of these intelligent agents that are capable of taking independent actions, based upon a set of criteria developed around decisions, can make the business process workable.

Moreover, the fundamental needs of consumers and businesses have remained much the same. Predominantly the consumers always want to compare products and services side by side for efficient cost comparison; businesses always want to grow sales by attracting

the shoppers via attractive pricing. Thus, we can make use of these intelligent agents to work on behalf of buyers and sellers over the internet.

Since these agents can process commands and execute decisions without any user intervention, they make life simpler and also improve the results obtained by the end user; these agents employ better search capabilities and are free from human-error. These agents can be as sophisticated at conducting negotiations with other agents to obtain the “best” deal possible. In the present project, we make use of the JADE software framework which facilitates the development of interoperable intelligent multi-agent systems required to build real applications. JADE framework is also compliant with FIPA specification that makes the JADE agents interoperable with other agent-based systems that comply with the same standard. JADE API is fully developed in Java, so portability is inherent to this framework.

2 Architecture of the MedTrading system

In our model, the MedTrading system acts as the Health Information Exchange (HIE) server that facilitates the users to carry out negotiations upon their requirements for either selling or buying. The MedTrading system has connections to the database server that maintains all user information and stores the output of the negotiations accordingly.

2.1 System Overview

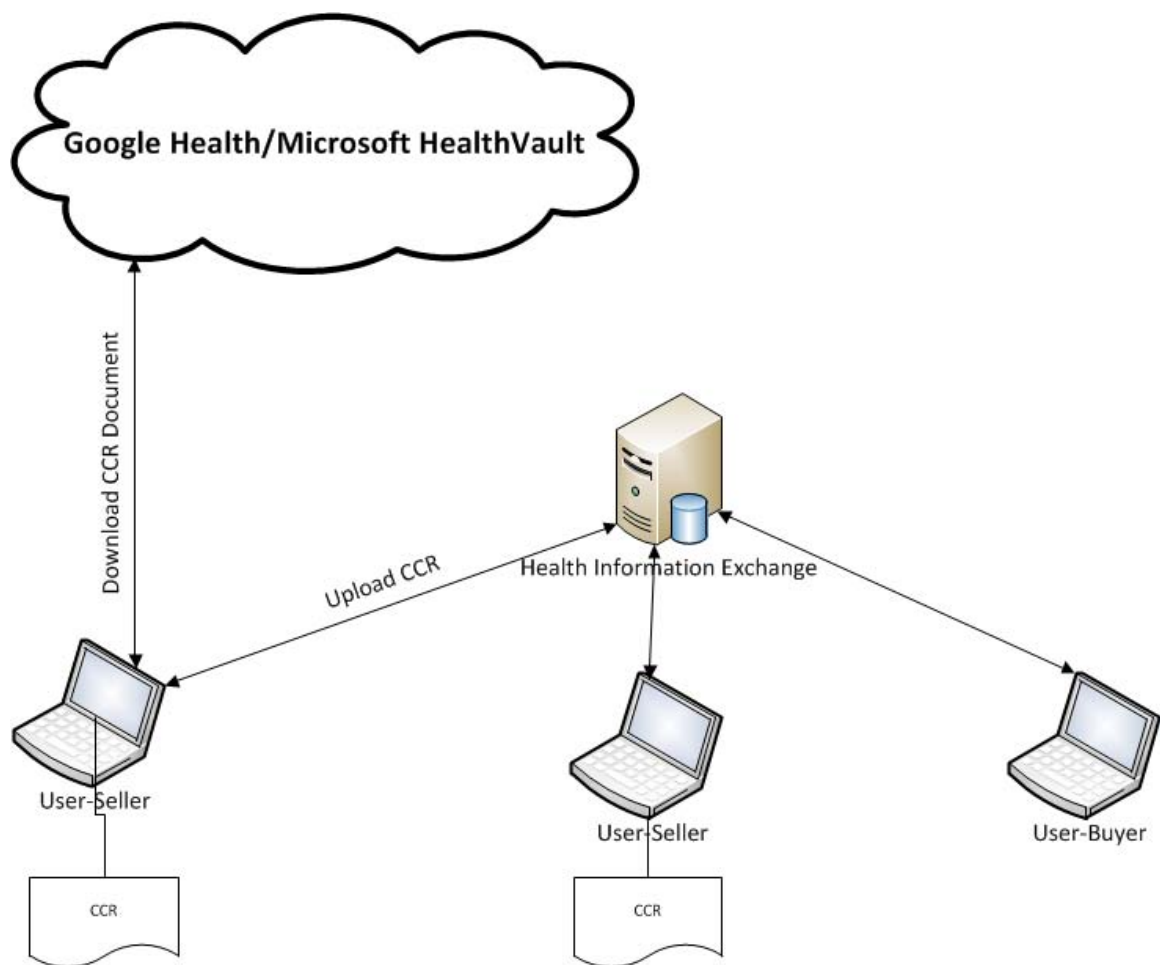

Figure 3: System Overview

Figure 3 shows the overview of the system in which the seller first downloads a copy of the CCR document from Google Health/Microsoft HealthVault. The seller then uploads

the document into the MedTrading system along with the “terms” file. The MedTrading application also provides some basic trading options like desired price and the time to remain alive to carry on the negotiating process.

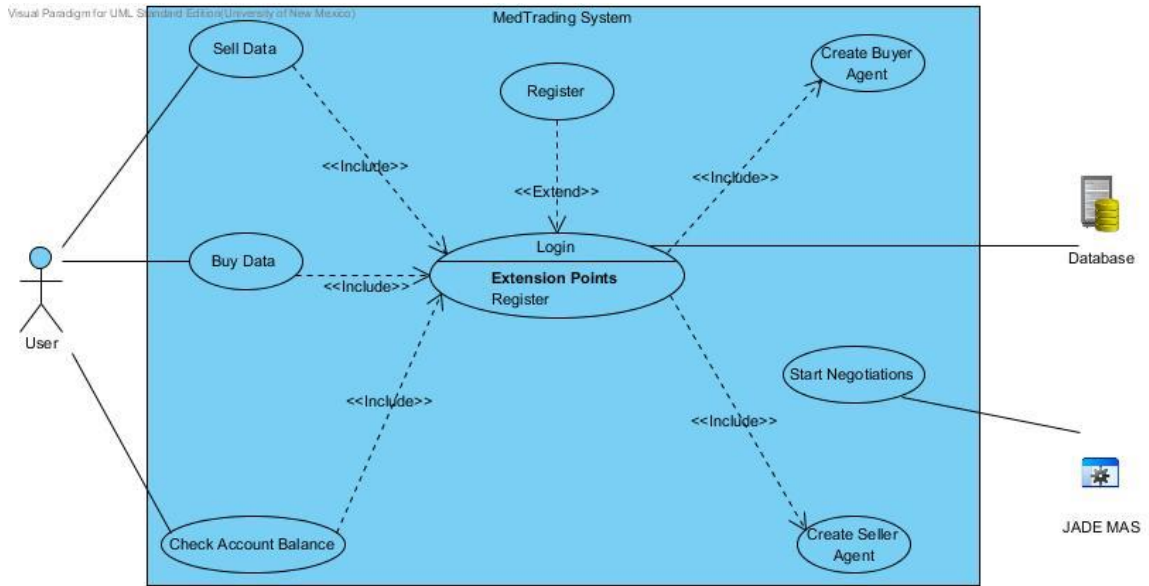

Figure 4: Use Case Diagram

2.2 Components

2.2.1 Source: CCR document

Google prohibits selling of data to a third party, whether personally identifiable or in aggregate form [13]. Microsoft requires consent from end-user in order to disclose end-user data to third party applications [14]. So we have divided the application into two parts. One side of it provides an interface for users to download the CCR documents while the other provides an interface for both the producers (patients/Sellers) and consumers (pharmaceutical companies, research facilities/Buyers) to negotiate over data. So the users themselves upload the CCR documents to our MedTrading system thus avoiding violation of the terms.

The Google Health Data API allows client applications to view and update Health content in the form of a Google Data API feed. Depending upon the user selection, the application has either full READ or READ/WRITE permissions. The Google Health Data API has client libraries in Java, .NET and PHP allowing developers to integrate existing software with Google Health. Microsoft HealthVault also has client libraries in .NET, Java and Ruby and the application can be permitted access at data type level.

For development, both Google Health and Microsoft HealthVault offer sandboxes to test the application.

The authentication and retrieval procedure in Google Health using PHP is as follows.

- 1) There are two methods to authenticate web applications: the AuthSub and OAuth methods of authorization. In AuthSub type of authorization, the users need not share their login credentials directly with the external website; instead the web application redirects the user to the Google Health Website and the user is authenticated by Google and a token is generated which is exchanged, allowing the external website to access the user profile on Google Health. In the OAuth method, the application first requests access to the user profile but gets an unauthorized request token from Google's authorization server. Then the user is asked for permission to grant access to the required data.

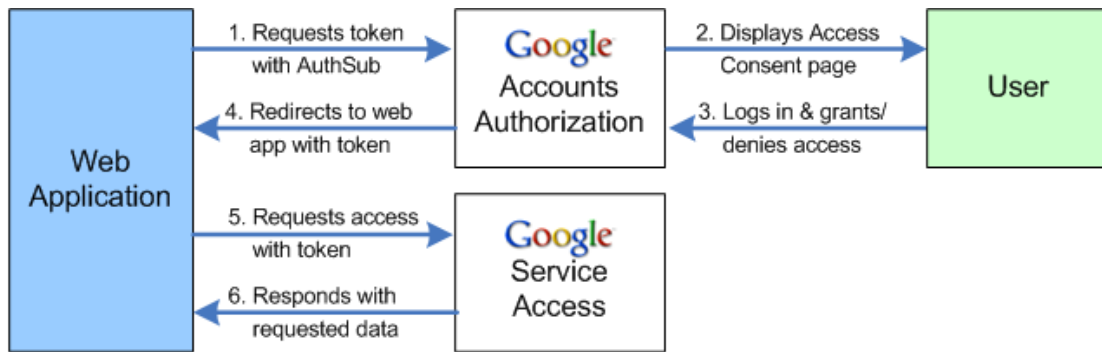

Figure 5: AuthSub Protocol

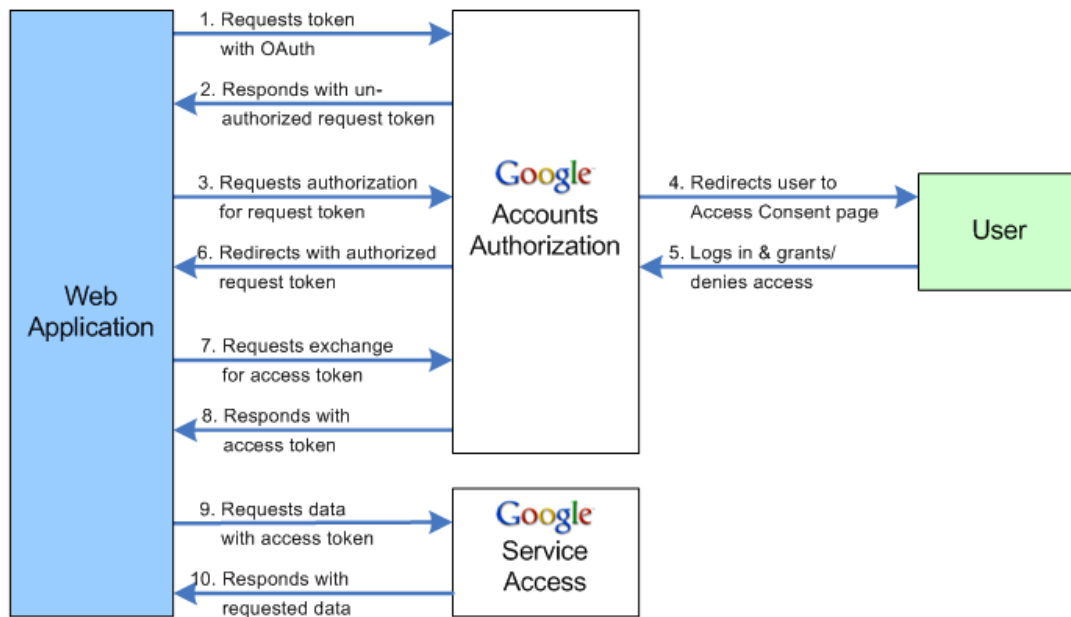

Figure 6: OAuth Protocol

2) After the client login authentication process, the user is redirected back to the next URL, usually our web application, with a single-use token appended to the end. The token is then extracted and upgraded to a session token for using it in subsequent transactions.

3) Google provides an extension to the Google Data PHP Client Library. The user's entire profile is stored in a CCR which can be retrieved from Google Data feeds whose XML elements are from the CCR namespace. Each profile is encapsulated inside of an Atom <atom:entry> feed. The data is extracted by sending a query

and then iterating through the feed to retrieve each CCR entry. The Zend_Gdata_Health_Extension_Ccr class makes use of PHP's magic __call method to extract a particular section of the CCR data.

- 4) The CCR document is downloaded on to the client's computer.

```
<?xml version="1.0"?>
- <ContinuityOfCareRecord xmlns="urn:astm-org:CCR">
  <CCRDocumentObjectID>o5hQgcyS6Zc</CCRDocumentObjectID>
  + <Language>
    <Version>V1.0</Version>
  + <DateTime>
  + <Patient>
  + <From>
  - <Body>
    + <Payers>
    + <FunctionalStatus>
    + <Problems>
    + <SocialHistory>
    + <Alerts>
    + <Medications>
    + <Immunizations>
    + <VitalSigns>
    + <Results>
    + <Procedures>
  </Body>
  + <Actors>
</ContinuityOfCareRecord>
```

Figure 7: Sample CCR

2.2.2 Unmarshalling XML document to Content Objects.

In order for accessing the XML document through the Java programming language, we made use of the Java Architecture for XML Binding (JAXB) API, Using JAXB, the XML schema is derived into classes and interfaces by the process of binding. The XML document is then unmarshalled into Java content objects. These objects represent the content and organization of the XML document and these objects can be

accessed directly by the Java program and the data can be displayed. The developer need not have any understanding of how the XML document is represented.

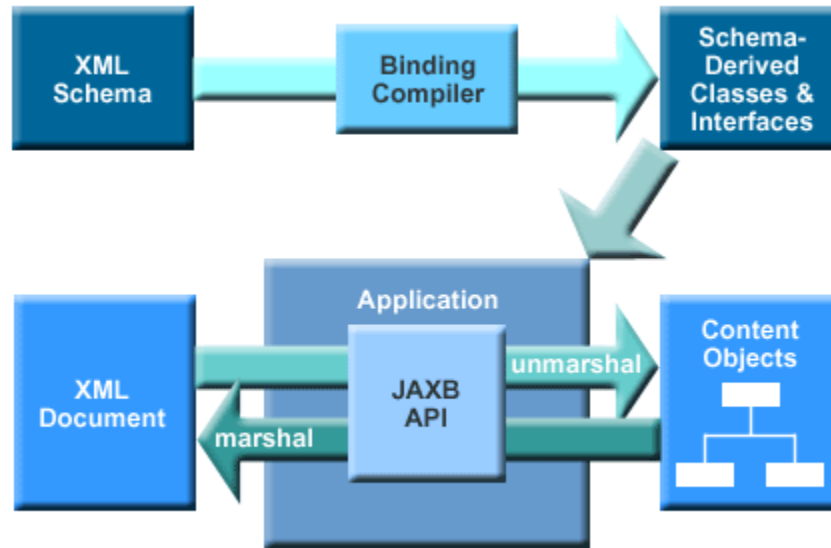

Figure 8: JAXB API

2.2.3 Health Vocabularies and Coding Systems.

A CCR usually allows multiple codes from different coding systems. Some of the codes that both Google Health and Microsoft HealthVault can interpret are:

1. Medications: RxNorm, NDC, FDB
2. Conditions and symptoms: SNOMED CT, ICD9, FDB
3. Procedures: CPT, SNOMED CT
4. Allergies: SNOMED CT
5. Immunizations: CPT
6. Lab test: LOINC, CPT, SNOMED

SNOMED CT (Systematized Nomenclature of Medicine -- Clinical Terms) is distributed by NLM, the U.S. Member of International Health Terminology Standards Development

Organisation (IHTSDO). SNOMED CT is a vast vocabulary of clinical terms that can be used to code, retrieve and analyze clinical data. Typically clinicians use different names at different points of care which might have the same meaning. Thus SNOMED CT was developed as a standardized terminology to facilitate better analysis of clinical information. With SNOMED CT, applications can be developed that work on clinical data for data aggregation, exchange and informational purposes.

The SNOMED CT vocabulary is comprised of concepts, descriptions and relationships.

Concepts are formally defined terms including descriptions of their relationships with other concepts and have unique numeric identifiers called ConceptIDs.

For example, 55822004 is the ConceptID for concept Hyperlipidemia (disorder).

Descriptions are used to name a concept. In case of synonyms there can be multiple descriptions for a single concept. Descriptions can be distinguished with their unique Description ID

Types of Descriptions

Fully Specified Name (FSN)

Every concept has an FSN and its main purpose is to identify a concept and clarify its meaning. It always ends with a semantic tag to specify the category that it belongs like disorder, finding, procedure etc.

For example,

Abdominal pain (finding), Osteoporosis (disorder), Anticoagulant therapy (procedure).

Preferred Term is used to represent a common name that is widely used for a concept.

A Preferred Term can be used for more than one concept.

Synonyms are used to represent the given concept.

Relationships

Relationships connect concepts in SNOMED CT. Every concept is logically represented with IS-A relationships and form the basis of the SNOMED CT's hierarchies.

For implementation we made use of the CORE Problem List Subset of SNOMED CT. Since SNOMED CT is a vast vocabulary, CORE Subset was developed to help starters focus on implementing SNOMED CT as the terminology for problem lists or other summary level clinical documentation.

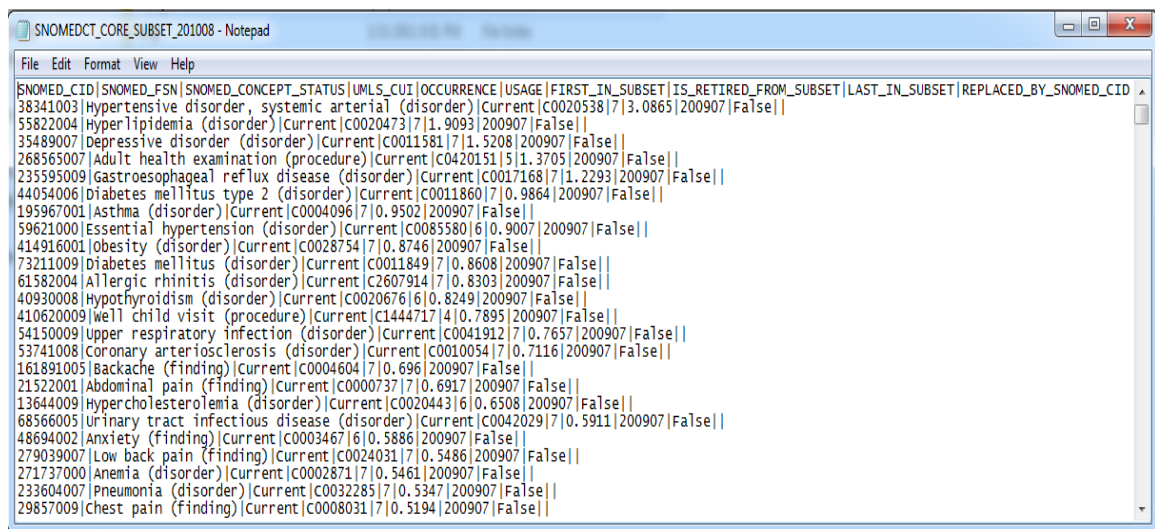

```
SNOMED_CID|SNOMED_FSN|SNOMED_CONCEPT_STATUS|UMLS_CUI|OCCURRENCE|USAGE|FIRST_IN_SUBSET|IS_RETIRED_FROM_SUBSET|LAST_IN_SUBSET|REPLACED_BY_SNOMED_CID
38341003|Hypertensive disorder, systemic arterial (disorder)|Current|C0020538|7|3.0865|200907|False|
55822004|Hyperlipidemia (disorder)|Current|C0020473|7|1.9093|200907|False|
35489007|Depressive disorder (disorder)|Current|C0011581|7|1.5208|200907|False|
268565007|Adult health examination (procedure)|Current|C0420151|5|1.3705|200907|False|
235595009|Gastroesophageal reflux disease (disorder)|Current|C0017168|7|1.2293|200907|False|
44054006|Diabetes mellitus type 2 (disorder)|Current|C0011860|7|0.9864|200907|False|
195967001|Asthma (disorder)|Current|C0004096|7|0.9502|200907|False|
59621000|Essential hypertension (disorder)|Current|C0085580|6|0.9007|200907|False|
414916001|obesity (disorder)|Current|C0028754|7|0.8746|200907|False|
73211009|Diabetes mellitus (disorder)|Current|C0011849|7|0.8608|200907|False|
61582004|Allergic rhinitis (disorder)|Current|C2607914|7|0.8303|200907|False|
40930008|Hypothyroidism (disorder)|Current|C0020676|6|0.8249|200907|False|
410620009|well child visit (procedure)|Current|C1444717|4|0.7895|200907|False|
54150009|upper respiratory infection (disorder)|Current|C0041912|7|0.7657|200907|False|
53741008|Coronary arteriosclerosis (disorder)|Current|C0010054|7|0.7116|200907|False|
161891005|Backache (finding)|Current|C0004604|7|0.696|200907|False|
21522001|Abdominal pain (finding)|Current|C0000737|7|0.6917|200907|False|
13644009|Hypercholesterolemia (disorder)|Current|C0020443|6|0.6508|200907|False|
68566005|Urinary tract infectious disease (disorder)|Current|C0042029|7|0.5911|200907|False|
48694002|Anxiety (finding)|Current|C0003467|6|0.5886|200907|False|
279039007|Low back pain (finding)|Current|C0024031|7|0.5486|200907|False|
271737000|Anemia (disorder)|Current|C0002871|7|0.5461|200907|False|
233604007|Pneumonia (disorder)|Current|C0032285|7|0.5347|200907|False|
29857009|Chest pain (finding)|Current|C0008031|7|0.5194|200907|False|
```

Figure 9: SNOMED CT CORE Problem List Subset

The fields of the SNOMED CT CORE subset data file are:

- SNOMED_CID – conceptId of the SNOMED CT concept
- SNOMED_FSN – SNOMED CT Fully Specified Name
- SNOMED_CONCEPT_STATUS – It just describes that only current SNOMED CT concepts are included
- UMLS_CUI – It is the corresponding UMLS concept identifier, if concept is not yet in the UMLS this will be NA

- OCCURRENCE – It is the number of institutions having this concept on their problem list (from 1 to 7)
- USAGE – the average usage percentage among all institutions
- FIRST_IN_SUBSET – the version of subset first containing this concept
- IS_RETIRED_FROM_SUBSET – IF IHTSDO drops the concept in future releases then it is marked retired
- LAST_IN_SUBSET – the version of Subset last containing this concept
- REPLACED_BY_SNOMED_CID – the concept that replaces the retired concept from Subset

Except the first two fields, we do not need any of the other fields as they are release-specific details and not actual clinical information (Source: IHTSDO)

RxNorm is a standardized nomenclature for clinical drugs and drug delivery devices. Due to the many commercial drug information systems available that use different naming conventions at different stages of patient care and organizations, a standardized nomenclature that can combine different source vocabularies within the Unified Medical Language System (UMLS) Metathesaurus to facilitate sharing of data across multiple systems was developed. RxNorm includes the name of the clinical drug along with its ingredients, strengths and dose forms.

For example:

For generic drug name-

Acetaminophen 500 MG Oral Tablet

For a branded drug name-

Acetaminophen 500 MG Oral Tablet [Tylenol]

For a generic drug pack-

{5 (Aspirin 325 MG Oral Tablet) / 5 (Pravastatin 20 MG Oral Tablet) } Pack

For a branded drug pack-

{30 (Aspirin 325 MG Oral Tablet) / 30 (Pravastatin 20 MG Oral Tablet
[Pravachol]) } Pack [Pravigard 325/20].

RxNorm provides information in the following files:

- RXCONSO, Concept and Source Information
- RXNREL, Relationships
- RXNSAT, Attributes
- RXNSTY, Semantic Type

(Source: www.nlm.nih.gov)

2.2.4 Java Agent DEvelopment Framework (JADE)

JADE is a software platform implemented in the Java language that facilitates the development of multi-agent systems (MAS). It is fully compliant with the Foundation for Intelligent Physical Agents (FIPA) specifications that enables it with standards that work over a vast number of software agent technologies.

The following JADE features make it the best choice when compared with other agent based systems.

- FIPA Compliance
- Distributed system – The agents can be deployed across network.
- Graphical Debugging tools

- Support for content languages and ontologies – With the help of ACL messages conversations can be coded into specific content languages and checked for proper semantics using a specified ontology.
- Exposure of agent services as web services and easy creation of agents using servlets.
- Support for mobile devices.
- Plethora of add-ons.

2.2.4.1 JADE Architecture

The JADE platform is composed of agent containers that provide the JADE run-time and services needed for hosting and executing agents. These containers which hold the agents are Java processes that can be distributed over the network.

The first container being the main container which initiates the procedure; any further containers register themselves with the main container.

The main container is also responsible for launching two special agents namely, Agent Management System (AMS) and Directory Facilitator (DF).

The task of AMS is to provide a naming service for all agents in the platform. Every agent is registered with the AMS and obtains an Agent Identifier (AID) when it is first created.

DF provides a Yellow Pages service which can help agents register their service or find other agents providing services.

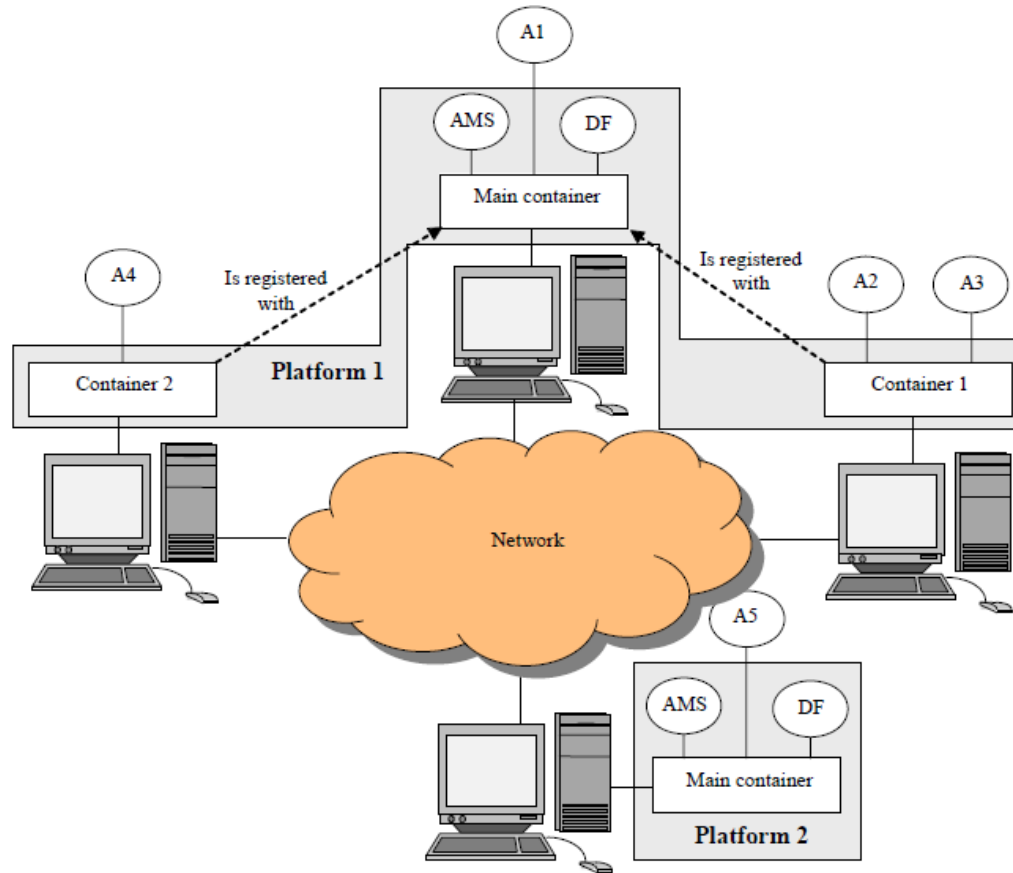

Figure 10: JADE Architecture

2.2.4.2 FIPA standards

The Foundation for Intelligent Physical Agents (FIPA) standards are developed to promote agent-based technology and the interoperability of its standards with other technologies.

Figure 11 shows the FIPA specifications that are available at the various levels of agents construction most of which have been implemented by JADE.

The primary aspect of agent based systems is communication. Agent communication in FIPA is comprised of a set of Interaction protocols, Communication Acts and Content Languages.

The FIPA Agent Communication Language (FIPA ACL) is a set of communicative acts required for effective agent communication. A FIPA ACL message structure contains a set of one or more message parameters.

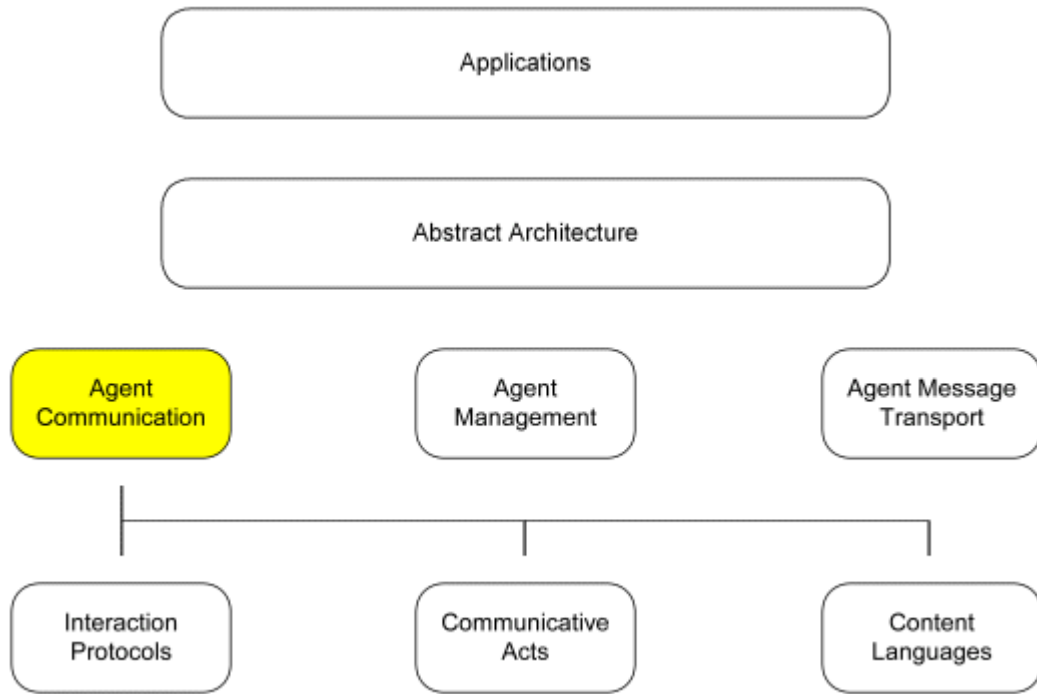

Figure 11: FIPA specifications classifications [Source: www.fipa.org]

Parameter	Category of Parameters
Performative	Type of communicative acts
Sender	Participant in communication
Receiver	Participant in communication
reply-to	Participant in communication
Content	Content of message
Language	Description of Content
Encoding	Description of Content
Ontology	Description of Content
Protocol	Control of conversation
conversation-id	Control of conversation
reply-with	Control of conversation
in-reply-to	Control of conversation
reply-by	Control of conversation

Table 1: FIPA ACL message parameters [9]

2.2.4.3 FIPA Communicative Acts

There are, in total 22, communicative acts specified in FIPA compliant acts library. With a standardized library, developers will find it very useful in writing agents that can interact with other agents using the same set of acts. Communicative acts also facilitate the development of customized interaction protocols for custom applications.

Communicative act	Summary
accept-proposal	The action of accepting a previously submitted proposal to perform an action
agree	The action of agreeing to perform some action, possibly in the future
cancel	The action of one agent informing another agent that the first agent no longer has the intention that the second agent perform some action.
Cfp (Call for Proposal)	The action of calling for proposals to perform a given action
confirm	The sender informs the receiver that a given proposition is true, where the receiver is known to be uncertain about the proposition
disconfirm	The sender informs the receiver that a given proposition is false, where the receiver is known to believe, or believe it likely that, the proposition is true.
failure	The action of telling another agent that an action was attempted but the attempt failed.
inform	The sender informs the receiver that a given proposition is true.
inform-if	A macro action for the agent of the action to inform the recipient whether or not a proposition is true.
inform-ref	A macro action for sender to inform the receiver the object which corresponds to a descriptor, for example a name.
not-understood	The sender of the act (for example, i) informs the receiver (for example, j) that it perceived that j performed some action, but that i did not understand what j just did.
propagate	The sender intends that the receiver treat the embedded message as sent directly to the receiver, and wants the receiver to identify the agents denoted by the given descriptor and send the received propagate message to them.
propose	The action of submitting a proposal to perform a certain action, given certain preconditions.
proxy	The sender wants the receiver to select target agents denoted by a given description and to send an embedded message to them.
query-if	the action of asking another agent whether or not a given proposition is true.

query-ref	The action of asking another agent for the object referred to by a referential expression.
refuse	The action of refusing to perform a given action, and explaining the reason for the refusal.
reject-proposal	The action of rejecting a proposal to perform some action during a negotiation.
request	The sender requests the receiver to perform some action.
request-when	The sender wants the receiver to perform some action when some given proposition becomes true.
request-whenever	The sender wants the receiver to perform some action as soon as some proposition becomes true and thereafter each time the proposition becomes true again.
subscribe	The act of requesting a persistent intention to notify the sender of the value of a reference, and to notify again whenever the object identified by the reference changes.

Table 2: FIPA Communicative Act Library [10]

2.2.4.4 FIPA Interaction Protocols

Based on the communicative acts, FIPA provides a set of predefined communication protocols that are made up of a sequence of messages which are common to real-world situations. These protocols help the developers to create applications that can communicate using this predefined communication pattern without any knowledge of the underlying domain. There are about 9 predefined protocols specified by FIPA. The one we are using to frame the negotiations in our model is the FIPA Contract Net Interaction Protocol.

In the FIPA Contract Net Interaction protocol, one agent (the Initiator) takes the role of a manager which wishes to have some task performed by one or more other agents and further wishes to optimize a function that characterizes the task. The characterization is commonly expressed as the price, in some domain specific way. For any given task, any number of the participants may respond with a proposal. The negotiations then continue with the proposed participants. [10]

```

(cfp
 :sender (agent-identifier :name Buyer@mydomain.com)
 :receiver (agent-identifier :name Seller@mydomain.com)
 :protocol fipa-contract-net
 :conversation-id data-trade
 :content((medCondition+conditionOfUse+options))
)

```

Figure 12: A sample FIPA-ACL message with cfp performative

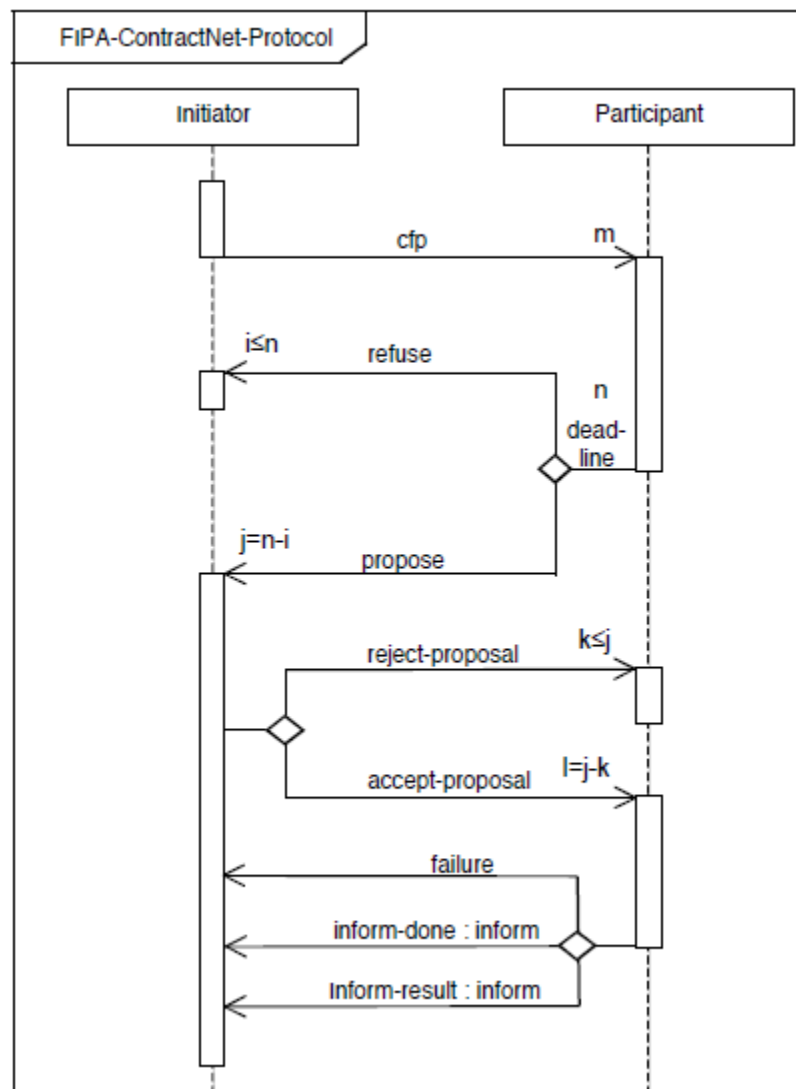

Figure 13: FIPA Contract Net Interaction Protocol

3 Implementation

3.1 Application Development

The implementation is divided into separate web applications. The first CCR Downloader application, aids the user in downloading the CCR document from Google Health servers. The second web application is our MedTrading exchange server application that communicates with the JADE multi-agent system and maintains all the user accounts, further it creates queries based on user inputs that are passed on to the agents.

3.1.1 CCR Downloader Application

The CCR Downloader Application has been developed using the Google Data PHP Client Library that connects with and uses the Google Health Data API. The application redirects the user to the H9 Developer's sandbox where the user is authenticated and is redirected back to our application with a token that can be used to access the user profile. Using the Zend GData classes, the user profile that is contained in an atom feed is downloaded in the form of XML. This XML file is then uploaded to the MedTrading system by the user.

3.1.2 The MedTrading exchange server application

The MedTrading exchange server application has been deployed as a Java servlet on Apache Tomcat Server backed with MySQL database connectivity. The servlet using the jade.wrapper.gateway classes can launch a container and create agents. The agents are passed, with parameters, given by the user needed for the negotiations.

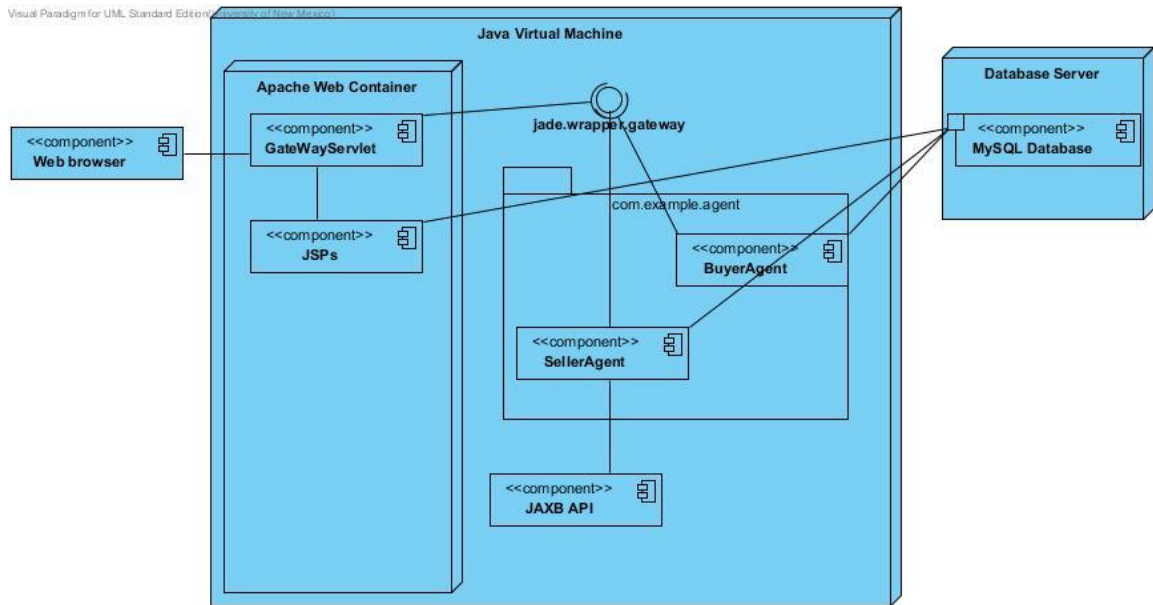

Figure 14: Deployment Diagram

3.2 Agents Development

Negotiations take place between agents representing buyers and sellers. The agents can be classified as minimum into two different types;

- 1) The Seller agent which is the Participant, puts its medical data on sale, proposes its offer to prospective buyer agents, distributes information when the proposal is accepted, and continues selling till specified by some time
- 2) The Buyer agent, which is the Initiator, calls for proposals from interested seller agents about a task; in our case requesting information, receiving proposals over a characteristic function such as price, accepting or refusing proposals, buying information and continues buying till specified by some time.

During the initialization phase, the seller agent (Participant) provides the Directory Facilitator (DF) Agent with a description about the list of services that it supports along with its AID. The `DFAgentDescription`, `ServiceDescription` and `Property` classes that are included in the `jade.domain.FIPAAgentManagement` package provide the abstractions to

create the service descriptions. The agent, after setting its AID and naming its service description calls the register() method notifying its registration.

```
DFAgentDescription dfd = new DFAgentDescription();
dfd.setName(getAID());
ServiceDescription sd = new ServiceDescription();
sd.setType("Data-selling");
sd.setName(getLocalName()+"-Data-selling");
dfd.addServices(sd);
try {
    DFService.register(this, dfd);
}
catch (FIPAException fe) {
    fe.printStackTrace();
}
```

Figure 15: Sample DF agent registration

The Buyer agent (Initiator), on the other hand, calls for proposals from seller agents (Participants) by issuing a call for proposals (cfp) act specifying that it needs information about a specific medical condition, its intended usage of the information and additional options for a price that include, if it wants to purchase, the whole CCR document outright or only part of the specific CCR element. The Seller Agents (Participants) that receive the call for proposals with agreed upon usage terms, responds with a propose act pertaining to the specific condition that the initiator places with a price. Among the n Participants if i number of Participants refuse, the Initiator receives $j=n-i$ proposals. When the deadline passes, the Initiator evaluates the received j proposals and selects the best (or alternatively may not choose any proposal). If a proposal is selected, an accept-proposal act is sent to that particular agent and reject-proposal act to all remaining k agents. After receiving the accept-proposal the Participant extracts either specific CCR element from the Java objects that were unmarshalled using JAXB or the entire CCR record and sends the Initiator with inform-result act to notify the task completion and the output. The

output is the information that the Initiator initially sought and the information is stored in the database completing the transaction. After the transaction is completed the Initiator which is the buyer agent, removes the seller agent AID from its list and proceeds to send call for proposals again to the remaining or any new Participants. The process is carried until the time deadline expires and then the agent is terminated. The negotiation, in terms of price, is formulated as a linear function of time. As the time passes, the Buyer will increase the price linearly until it reaches the maximum price allowed whereas the Seller will decrease the price linearly until it reaches the minimum price. Figure 16 shows the sequence diagram for a Buyer using the MedTrading system.

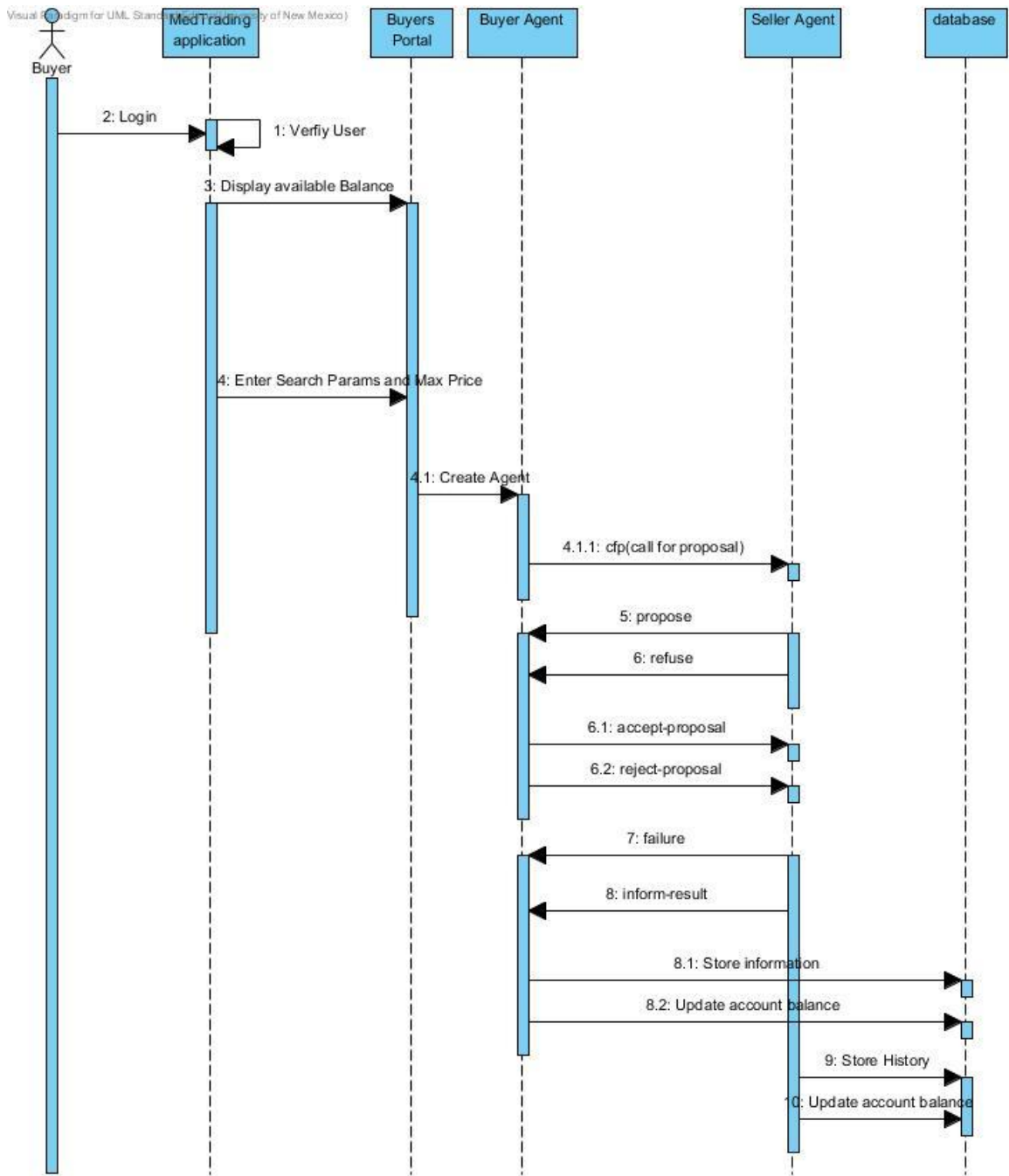

Figure 16: Sequence Diagram of Buyer

4 The framework in Action

4.1 The CCR Downloader Application

The CCR Downloader Application working is demonstrated through the following sequence of figures. The CCR Downloader Application webpage redirects to the Google Health Authentication webpage as shown in Figure 17.

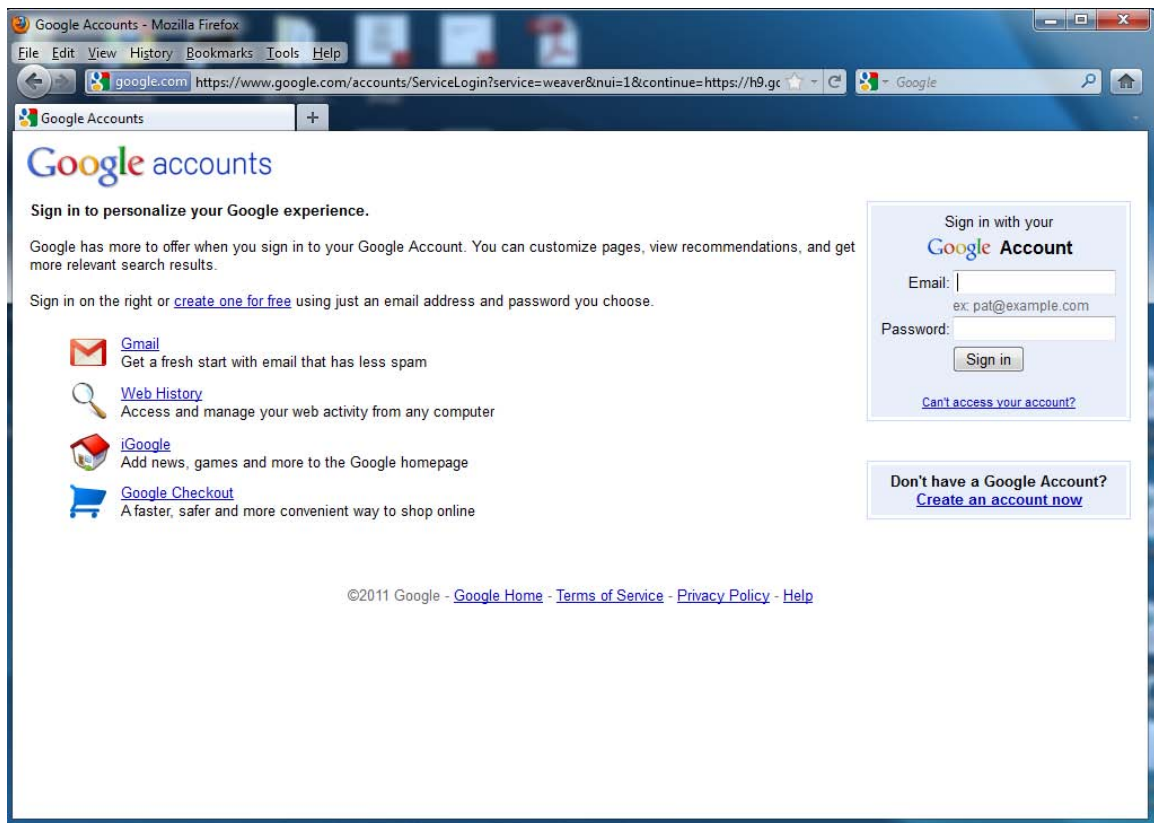

Figure 17: User is redirected to H9 Sandbox where authentication is done

The user is next asked to authenticate the external application to access the Google Health account pertaining to this user. Once the user clicks “Yes, link my accounts” the application receives a token that it can use further to access the user profile.

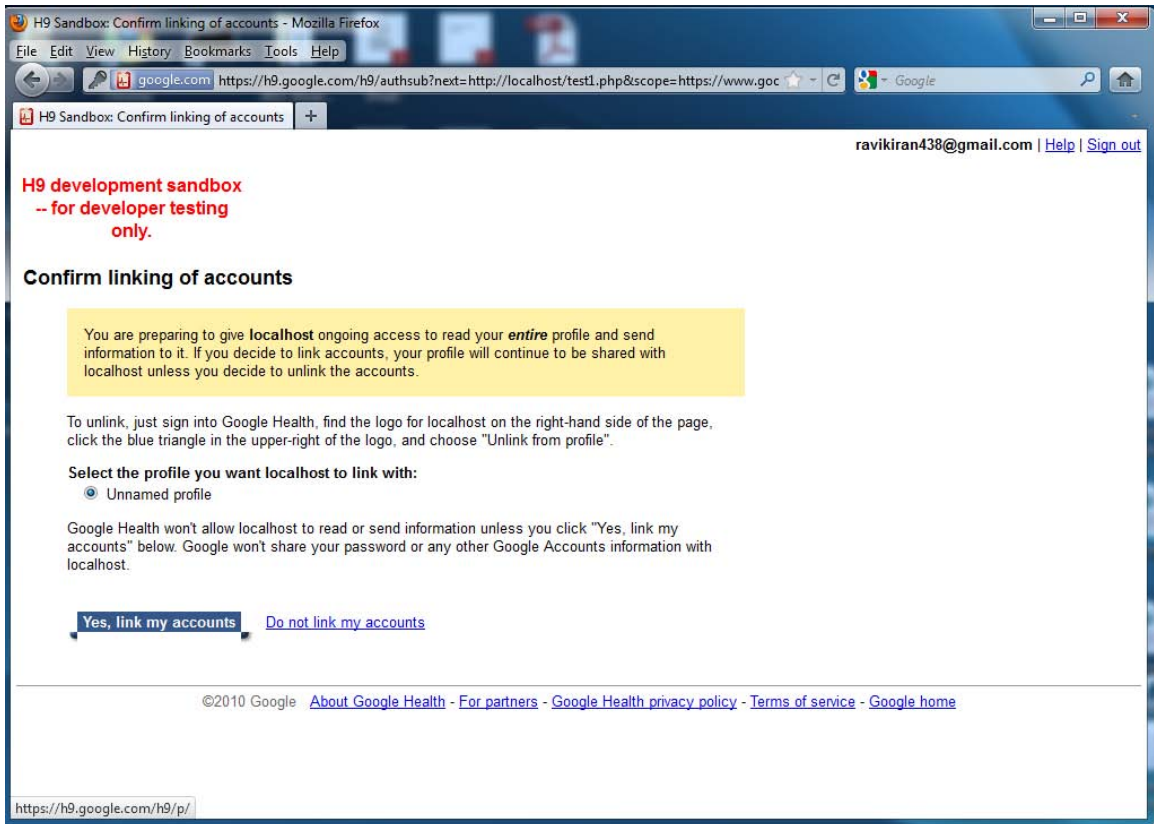

Figure 18: User authorizes the application access to the profile

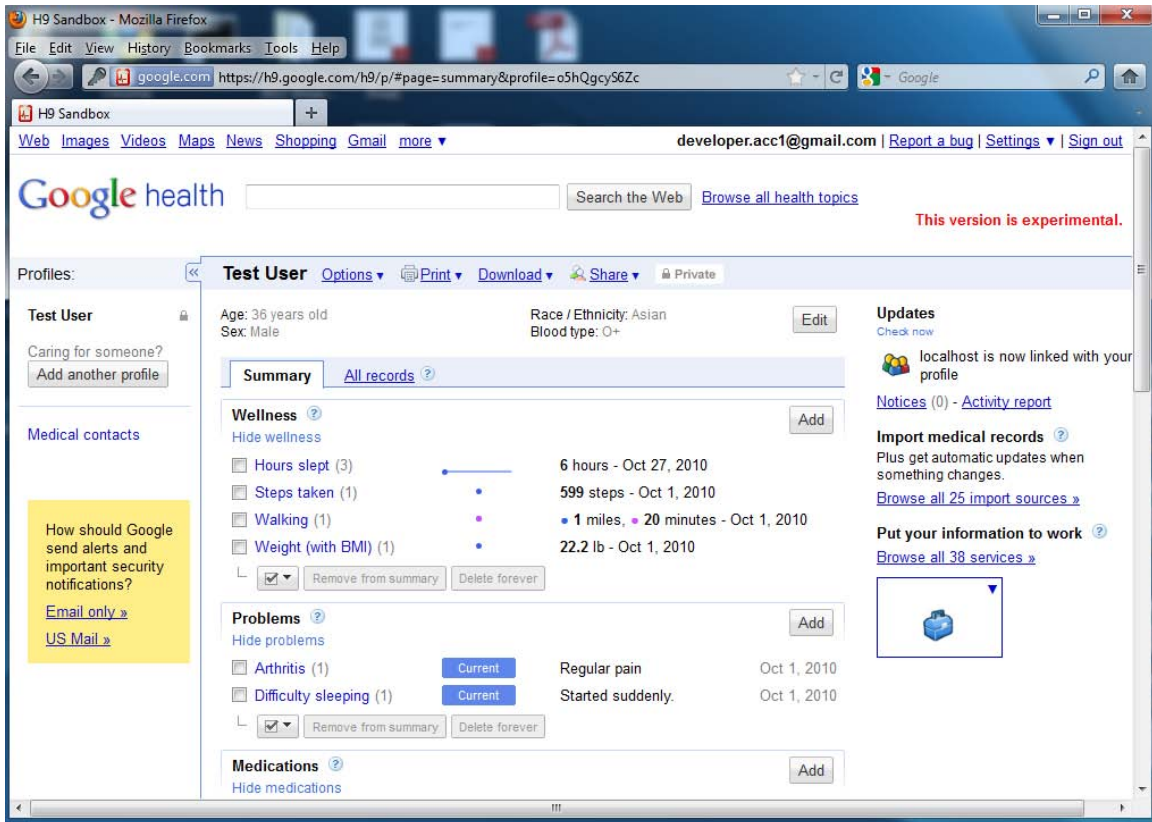

Figure 19: Google Health Web Interface to enter Health Information

The user can then download the CCR document onto his computer which can be used with the MedTrading exchange server.

4.2 MedTrading Exchange Server in Action

The steps to follow include how the user of the application server starts the negotiations.

In the first step, the user is asked to enter his login credentials or, if he is new to the system, to register with the system. The figure below shows the login page for our MedTrading application.

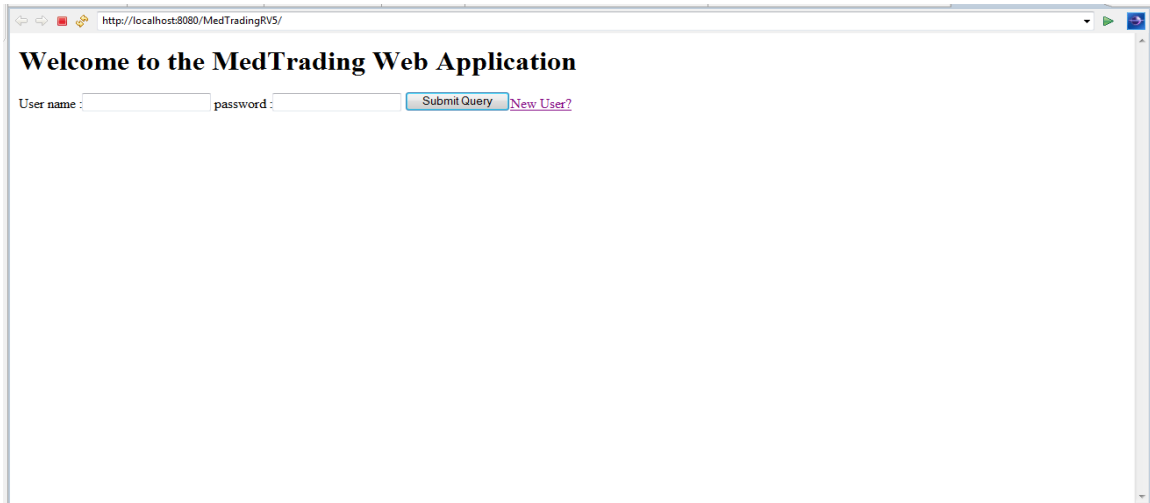

Figure 20: Login Page

In the second step, the user is directed to a page where he selects, a Buyer or a Seller role.

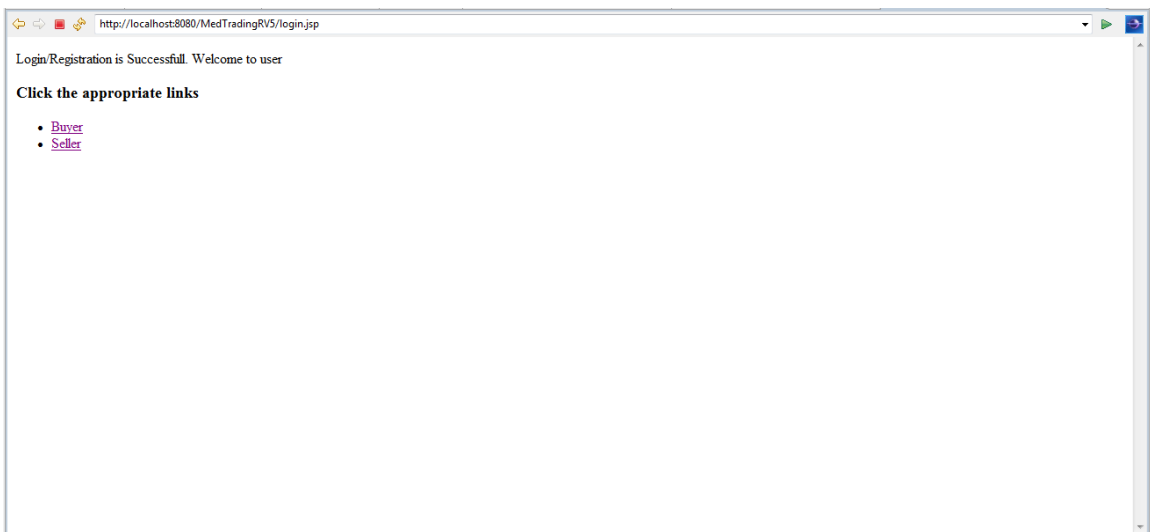

Figure 21: User choice selection

Depending upon the choice of participation, the user is redirected to the appropriate page.

The Figure 22 below shows the interface for a Buyer.

Available balance = 500
Please fill in the form to start the automatic negotiation

Looking For: Please Type in only disorders

Looking For: Drug

License Type:

Need Full CCR file Yes No

Max Cost

Deadline in ms

Start Processing

- Asthma (disorder)
- Asthenia (finding)
- Asthmatic bronchitis (disorder)
- Asthma without status asthmaticus (disorder)
- Asthma with status

Figure 22: Buyer Interface

In the above figure, the User is shown the available balance in his account and a set of options to start of the negotiations process. The Buyer can select the type of disorder for which he needs information about the particular drug the patient uses. Alternatively, the user can select both the disorder and drug information and then request the full CCR file from the seller to study the allergies and also other medications that the patient uses along with the current drug. The user also needs to select the type of usage. For example: for commercial purposes or non-commercial purposes that include research. The user must indicate maximum price that is acceptable and the maximum time the agent that acts on behalf of the user has to remain alive.

If the user has made the selection as a Seller, the interface for the Seller will be as shown below.

Available balance = 500

Please Enter Your Name and Upload your CCR Document and Terms Document Below

Upload CCR Here

Upload Terms file

Starting Price

Min Price

Price for Full CCR

Deadline in ms

Start Processing

[Go Back](#)

Figure 23: Seller Interface

The Seller will be displayed with the current balance in his account. The web interface provides fields to upload the CCR file obtained from Google Health and then another field to upload the usage terms file. A typical usage terms file is as shown below.

```

- <terms>
  - <usage>
    <type>commercial-use</type>
  </usage>
</terms>

```

Figure 24: A sample of the terms file

The usage terms file indicates the user's decision regarding participating in negotiations with Buyer agents. If the user is interested in selling data to research facilities, the type would indicate non-commercial-use and the user might just auction the data for a lower price for research facilities.

In both the scenarios, once the user clicks the submit button, respective agents will be created on the JADE main container that send messages to each other in the process of negotiation.

Below is the output from the console showing agents being created.

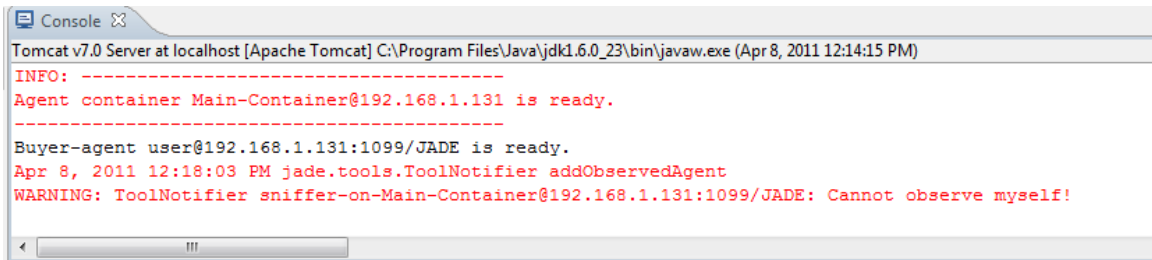

```
Tomcat v7.0 Server at localhost [Apache Tomcat] C:\Program Files\Java\jdk1.6.0_23\bin\javaw.exe (Apr 8, 2011 12:14:15 PM)
INFO: -----
Agent container Main-Container@192.168.1.131 is ready.
-----
Buyer-agent user@192.168.1.131:1099/JADE is ready.
Apr 8, 2011 12:18:03 PM jade.tools.ToolNotifier addObservedAgent
WARNING: ToolNotifier sniffer-on-Main-Container@192.168.1.131:1099/JADE: Cannot observe myself!
```

Figure 25: Console output

The conversations between the agents can be visualized via a sniffer agent that is provided by JADE for debugging purposes. The Figure 26 below shows a graphical representation of the messages that are exchanged between the Buyer and Seller Agents, where each arrow represents a message with its direction and different colors to identify a particular conversation.

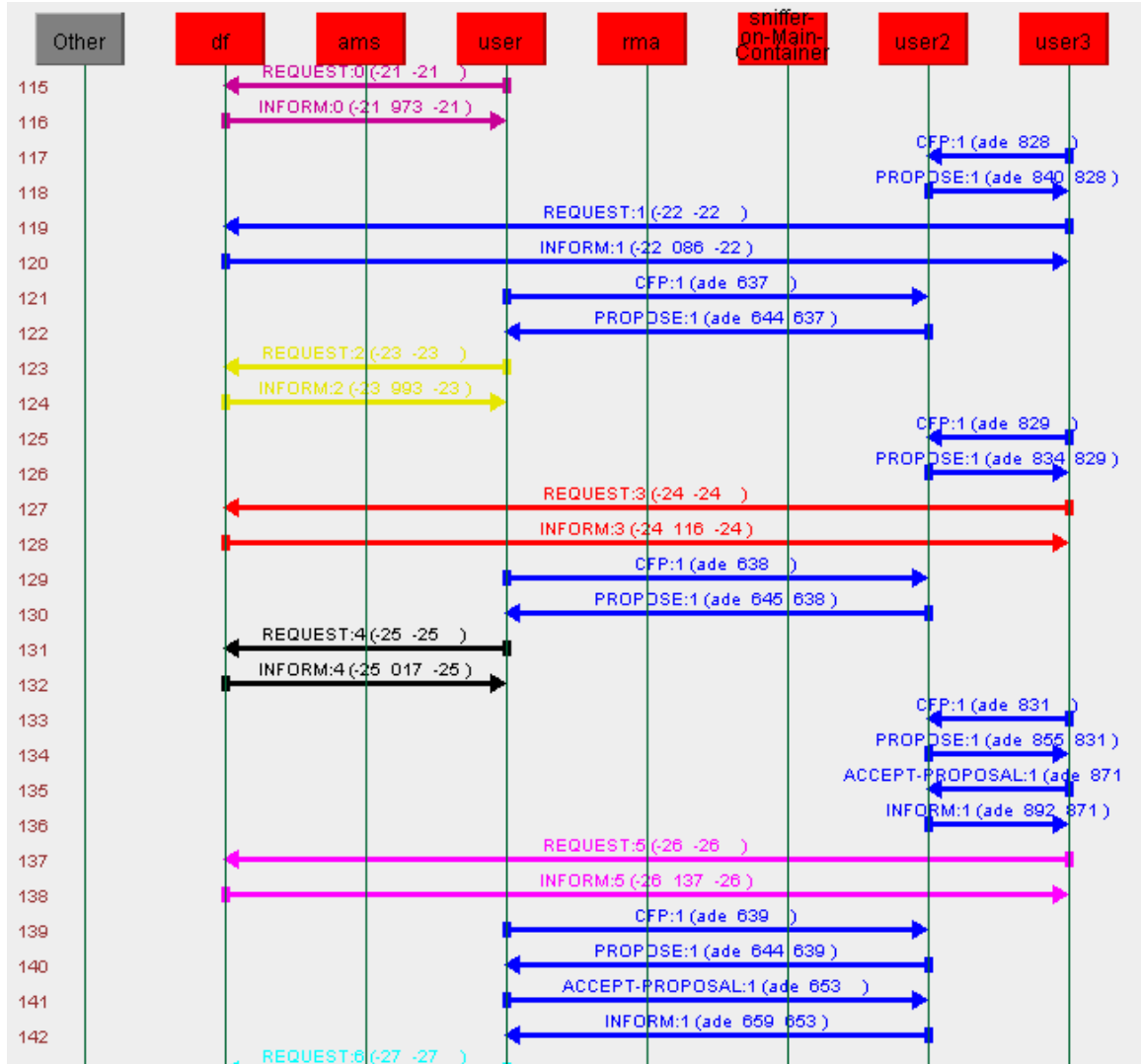

Figure 26: Conversation Visualization with the help of Sniffer Agent

In this scenario, there are two Buyer agents requesting some information and one Seller agent that responds to these Buyer agents. The negotiation is carried according to the FIPA Contract Net Interaction Protocol. After successful completion of negotiation, the database corresponding to the users of these agents is updated accordingly. For Buyer agent, the information is stored in XML format and the account balance is decremented by the amount made for the purchase of information. For the Seller agent, its corresponding user account balance is incremented every time it sells some information.

5 Conclusions and Future Work

The MedTrading exchange server is the proof of concept that we have envisioned and have successfully implemented. We developed a system that makes users more powerful with a more appropriate Usage Managed Health Record (UMHR) for the scenario. Allowing users to manage the usage of their personal health records and share health data with prospective drug companies and research facilities with monetary gains has a great deal of potential for changing the entire scenario as to how healthcare is delivered. This approach will significantly reduce the time to know about drug safety issues and also the money required for the development of new drugs. It can also help in understanding the effectiveness of the drug over a large population through the available data. Incentives can be in the form of money or any other means but will encourage participants to get involved in sharing their information.

In the future, this model can be further extended to include features such as security mechanisms for the web application, data authenticity checking to verify the accuracy of data provided by the users through certifications or digital signatures and an ontology that will aid processing of complex messages by the agents.

6 References

1. Scott Endsley, David C. Kibbe, Anthony Linares, Karen Colorafi, “An Introduction to Personal Health Records”. *Fam Pract Manag.* 2006 May;13(5):57-62.
2. ASTM E2369 - 05e1 Standard Specification for Continuity of Care Record (CCR).
URL: <http://www.astm.org/Standards/E2369.htm>
3. Ashish Singh, Preston Henske, “Has The Pharmaceutical Blockbuster Model Gone Bust?”, a Bain & Company press release 12/08/2003.
4. Katie Zingg, “FDA Post-market Drug Surveillance: In Need Of an Overhaul”, 2007.
5. Weitzman ER, Kaci L, Mandl KD, “Sharing Medical Data for Health Research: The Early Personal Health Record Experience”, *J Med Internet Res* 2010;12(2):e14
URL: <http://www.jmir.org/2010/2/e14/>
6. Joseph Conn, “Standards rivals' collaboration could have major impact”, URL: <http://www.modernhealthcare.com/article/20070213/FREE/70213004#>, Feb 13, 2007
7. Encouraging the Use of, and Rethinking Protections for De-Identified (and “Anonymized”) Health Data, Center for Democracy & Technology, June 2009
8. Charles Safran, Meryl Bloomrosen, W. Edward Hammond, Steven Labkoff, Suzanne Markel-Fox, Paul C. Tang, Don E. Detmer, “Toward a National Framework for the Secondary Use of Health Data: An American Medical Informatics Association White Paper”,

URL: https://www.amia.org/files/workforthesecondaryuseofhealthdata_09_08_06_.pdf

9. [FIPA00061] FIPA ACL Message Structure Specification. Foundation for Intelligent Physical Agents, 2000. URL: <http://www.fipa.org/specs/fipa00061/>

10. [FIPA00037] FIPA Communicative Act Library Specification Foundation for Intelligent Physical Agents, 2000. URL: <http://www.fipa.org/specs/fipa00037/>

11. [FIPA00029] FIPA Contract Net Interaction Protocol Specification Foundation for Intelligent Physical Agents, 2000. URL: <http://www.fipa.org/specs/fipa00029/>

12. Developing Multi-Agent Systems with JADE, “Fabio Bellifemine, Giovanni Caire, Dominic Greenwood”, John Wiley & Sons, Ltd.

13. Google Health Developer Policies, September 2, 2010,

URL: <http://www.google.com/intl/en-US/health/about/devpp.html>

14. Microsoft HealthVault Operating and Privacy Requirements,

URL: <http://msdn.microsoft.com/en-us/healthvault/cc268231.aspx>

15. JADE Tutorial, JADE Programming For Beginners, 30 June 2009.