

May 2016

On the Scattering of an Acoustic Plane Wave by a Soft Prolate Spheroid

Joseph Michael Borromeo
University of Nevada, Las Vegas, borrome4@unlv.nevada.edu

Follow this and additional works at: <https://digitalscholarship.unlv.edu/thesesdissertations>



Part of the [Acoustics, Dynamics, and Controls Commons](#), [Applied Mathematics Commons](#), and the [Mathematics Commons](#)

Repository Citation

Borromeo, Joseph Michael, "On the Scattering of an Acoustic Plane Wave by a Soft Prolate Spheroid" (2016). *UNLV Theses, Dissertations, Professional Papers, and Capstones*. 2643.
<https://digitalscholarship.unlv.edu/thesesdissertations/2643>

This Thesis is protected by copyright and/or related rights. It has been brought to you by Digital Scholarship@UNLV with permission from the rights-holder(s). You are free to use this Thesis in any way that is permitted by the copyright and related rights legislation that applies to your use. For other uses you need to obtain permission from the rights-holder(s) directly, unless additional rights are indicated by a Creative Commons license in the record and/or on the work itself.

This Thesis has been accepted for inclusion in UNLV Theses, Dissertations, Professional Papers, and Capstones by an authorized administrator of Digital Scholarship@UNLV. For more information, please contact digitalscholarship@unlv.edu.

ON THE SCATTERING OF AN ACOUSTIC PLANE WAVE
BY A SOFT PROLATE SPHEROID

by

Joseph Michael Borromeo

Bachelor of Science - Mathematics
University of Nevada, Las Vegas
2011

A thesis submitted in partial fulfillment
of the requirements for the

Master of Science - Mathematical Sciences

Department of Mathematical Sciences
College of Sciences
The Graduate College

University of Nevada, Las Vegas
May 2016

© 2016

Joseph M. Borromeo

ALL RIGHTS RESERVED



Thesis Approval

The Graduate College
The University of Nevada, Las Vegas

April 18, 2016

This thesis prepared by

Joseph Borromeo

entitled

On the Scattering of an Acoustic Plane Wave by a Soft Prolate Spheroid

is approved in partial fulfillment of the requirements for the degree of

Master of Science - Mathematical Sciences
Department of Mathematical Sciences

Dieudonne Phanord, Ph.D.
Examination Committee Chair

Kathryn Hausbeck Korgan, Ph.D.
Graduate College Interim Dean

Amei Amei, Ph.D.
Examination Committee Member

Rohan J. Dalpatadu, Ph.D.
Examination Committee Member

Diejo Assane, Ph.D.
Graduate College Faculty Representative

ABSTRACT

On the Scattering of an Acoustic Plane Wave

by a Soft Prolate Spheroid

By

Joseph M. Borromeo

This thesis solves the scattering problem in which an acoustic plane wave of propagation number K_1 is scattered by a soft prolate spheroid. The interior field of the scatterer is characterized by a propagation number K_2 , while the field radiated by the scatterer is characterized by the propagation number K_3 . The three fields and their normal derivatives satisfy boundary conditions at the surface of the scatterer. These boundary conditions involve six complex parameters depending on the propagation numbers. The scattered wave also satisfies the Sommerfeld radiation condition at infinity. Through analytical methods, series representations are constructed for the interior field and scattered field for an arbitrary sphere and a prolate spheroid. In addition, results for the reciprocity relations and Energy theorem are derived. Application to detection of whales and submarines are discussed, as well as classification of fish, squid and zoo plankton. In general Ref[] is used for reference and the work is done in three dimensions.

ACKNOWLEDGMENTS

This thesis could not have been completed by my effort alone and it would therefore sound ungrateful if I did not acknowledge the contributions and assistance of the following people.

First and foremost, I must express my gratitude to Dr. (Professor) Dieudonne D. Phanord for all of his time, guidance and patience. Without his mentor-ship, this work could not have been completed to the level of thoroughness required. His many years of studying and writing papers on scattering became quite obvious very early in the process of writing this paper. His knowledge and experience was instrumental in my research.

I also wish to express my heartfelt gratitude to my committee members, Dr. Rohan Dalpatadu, Dr. Amei Amei and Dr. Djeto Assane for their time, dedication and invaluable input.

I would not have said it all if I did not render special thanks to my parents Mr. And Mrs. Joseph C. Borromeo, my beautiful fiancée and soon to be wife Erika, and my sister Laurie for their love and support throughout my graduate education. They are the reason I have made it this far.

TABLE OF CONTENTS

Abstract	iii
Acknowledgments	iv
List of Figures	viii
Chapter 1. INTRODUCTION	1
1.1. Incident Wave ϕ_i	3
1.2. Interior Field ψ_{in}	3
1.3. Scattered Wave u	3
1.4. Boundary Conditions	4
1.5. Scattering Amplitude	5
1.6. Comparison to Twersky	5
Chapter 2. EXISTING RESULTS	7
2.1. Single Object in Isolation	7
2.2. Separation of Variables	8
2.2.1. Azimuthal Equation	10
2.2.2. Polar Equation	11
2.2.3. Radial Equation	13
2.2.4. Series Solutions	13
2.3. Transition Conditions	14
2.4. Radiation Condition	16
2.5. Green's Function Representation	17

2.6.	Scattering Amplitude	20
2.7.	Reciprocity Relation and Energy Theorem	22
2.7.1.	Reciprocity Relation	22
2.7.2.	Energy Theorem	24
Chapter 3. PLANE WAVE SCATTERING BY SOFT PROLATE SPHEROID-		
S	27
3.1.	Overview of a Prolate Spheroid	27
3.2.	Definition of a Prolate Spheroid	28
3.3.	Separation of Variables in Prolate Spheroidal Coordinates	33
3.3.1.	Angular Prolate Spheroidal Equation	37
3.3.2.	Power Series Expansion for $S_{mn}(\gamma, \eta)$	37
3.3.3.	Radial Prolate Spheroidal Equation	39
3.3.4.	The ϕ -dependent Prolate Spheroidal Equation	40
3.4.	Returning to the Scattering Problem	41
3.5.	Transition Conditions and the Expansion Coefficients	42
3.6.	Green's Function Representation	44
3.7.	Operator Form of the Spheroidal Scattering Amplitude	45
3.8.	Reciprocity Relation and Energy Theorem	47
3.8.1.	Reciprocity Relation	47
3.8.2.	Energy Theorem	48
3.8.3.	Energy Theorem for a Lossy and a Gainy Scatterer	49
Chapter 4. APPLICATIONS		
4.1.	C. Yeh	51

4.2.	T. Okumura, T. Masuya, Y. Takao and K. Sawada	52
4.3.	N. Gorska and D. Chu	54
Chapter 5.	CONCLUSION AND FUTURE WORK	57
5.1.	Conclusion	57
5.2.	Future work	58
5.2.1.	Extension to Oblate Spheroidal Geometry	58
5.2.2.	Numerical Calculations	58
5.2.3.	Multiple Scattering	59
Appendix A.	NOTATION AND CONVENTIONS FOR COORDINATE SYSTEMS	60
A.1.	Oblate Spheroidal Coordinates	60
References	62
Curriculum Vitae	67

LIST OF FIGURES

Figure 1.1. Vizualization of the Three Media (Spheriodal)	1
Figure 2.1. Vizualization of the Three Media (Spherical)	7
Figure 3.1. Prolate Spheroid	27
Figure 3.2. Prolate Spheroid	28
Figure 3.3. Vizualization of the Three Media (Spherical)	28
Figure 3.4. Elliptic Cylindrical Coordinates	29
Figure 3.5. Vizualization of the Three Media (Spheroidal)	41

CHAPTER 1

INTRODUCTION

This thesis solves for the interior field ψ_{in} and scattered wave u due to an incident plane wave ϕ_i scattered by a soft spheroidal object. The scatterer is a prolate spheroid whose surface is $\mathcal{S} \subset \mathbb{R}^3$, and the volume bounded by \mathcal{S} is $\mathcal{V} \subset \mathbb{R}^3$. The scatterer is embedded in a medium of volume V , characterized by the propagation vectors \mathbf{K}_1 and \mathbf{K}_3 . See Figure 1.1 The interior volume \mathcal{V} is a second medium

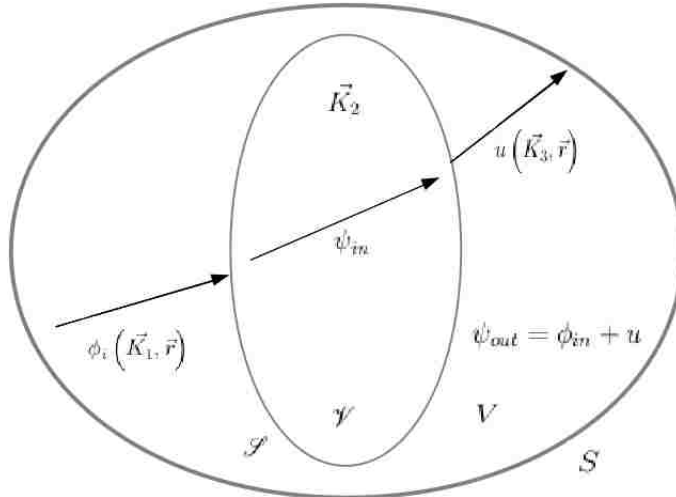

Figure 1.1: Visualization of the Three Media (Spheroidal)

described by its own propagation vector $\mathbf{K}_2 = k\eta'\mathbf{i}'$, where η' is the relative index of refraction of the interior medium. As in Ref [1], we permit the scatterer to be excited in \mathbf{K}_1 space and radiate in \mathbf{K}_3 space.

The problem is generally modeled by the wave equation,

$$\left(\nabla^2 - \frac{1}{c^2} \frac{\partial^2}{\partial t^2} \right) \Psi = 0, \quad (1.1)$$

and the time component is assumed to be harmonic. That is to say

$$\Psi(\mathbf{r}, t) = \psi(\mathbf{r}) e^{-i\omega t},$$

where the angular frequency $\omega = \frac{2\pi}{\tau}$ and τ is the period of oscillations Ref [2]. When substituted into 1.1, leads to the Helmholtz equation

$$(\nabla^2 + K^2) \psi(\mathbf{r}) = 0, \quad (1.2)$$

where $K = \frac{\omega}{c}$. Equation 1.2 is referred to sometimes in the literature as the reduced wave equation. In this entire thesis the harmonic time dependence is suppressed.

Due to the geometry of the soft prolate spheroidal scatterer, the coordinate system required to support the work and the symmetries involved are prolate spheroidal coordinates. They are given by:

$$x = c\sqrt{(\xi^2 - 1)(1 - \eta^2)} \cos \phi, \quad (1.3)$$

$$y = c\sqrt{(\xi^2 - 1)(1 - \eta^2)} \sin \phi, \quad (1.4)$$

$$z = c\xi\eta, \quad (1.5)$$

with $1 \leq \xi < +\infty$, $-1 \leq \eta \leq 1$, and $0 \leq \phi \leq 2\pi$. In prolate spheroidal coordinates, the Laplacian, ∇^2 , takes the form

$$\nabla^2 \equiv \frac{1}{c^2(\xi^2 - \eta^2)} \left[\frac{\partial}{\partial \xi} \left((\xi^2 - 1) \frac{\partial}{\partial \xi} \right) + \frac{\partial}{\partial \eta} \left((1 - \eta^2) \frac{\partial}{\partial \eta} \right) + \frac{\xi^2 - \eta^2}{(\xi^2 - 1)(1 - \eta^2)} \frac{\partial^2}{\partial \phi^2} \right]$$

Ref [3]. (1.6)

In the sequel, the incident wave ϕ_i , the scattered wave u , the interior solution ψ_{in} and total outside solution $\psi = \phi_i + u$ will be considered.

1.1 Incident Wave ϕ_i

The incident wave used to solve the problem is a plane wave of the form $\phi_i = e^{i\mathbf{K}_1 \cdot \mathbf{r}}$, where the observation vector is $\mathbf{r} = r\hat{\mathbf{o}}$ and the propagation vector is $\mathbf{K}_1 = k\eta\hat{\mathbf{i}}$. The direction of propagation is $\hat{\mathbf{i}}$, while the direction of observation is $\hat{\mathbf{o}}$ and $|\hat{\mathbf{i}}| = |\hat{\mathbf{o}}| = 1$. Since the problem is about propagation of an acoustic wave, it is always appropriate to impose the requirement that $\hat{\mathbf{o}}$ is parallel to $\hat{\mathbf{i}}$. The incident wave must satisfy

$$(\nabla^2 + K_1^2) \phi_i = 0, \quad (1.7)$$

where $K_1 = k\eta$.

1.2 Interior Field ψ_{in}

The soft prolate spheroidal scatterer is penetrable. Therefore, there exists an interior field ψ_{in} satisfying the following Helmholtz equation,

$$(\nabla^2 + K_2^2) \psi_{in} = 0 \quad (1.8)$$

and is regular at the center of the prolate spheroidal object.

1.3 Scattered Wave u

In V , the scattered region, u , the scattered wave, satisfies also the reduced wave equation,

$$(\nabla^2 + K_3^2) u = 0. \quad (1.9)$$

Similar to equation 5 in Ref [1], $K_3 = k = |\mathbf{k}| = \frac{2\pi}{\lambda}$, where λ is the wave length. The scattered wave, u , must satisfy the Sommerfeld radiation condition at infinity Ref [1],

$$\lim_{r \rightarrow \infty} r^{(n-1)/2} (\partial_r u - iK_3 u) = 0, \quad (1.10)$$

where n is the dimensionality of the space. Also u must be bounded and must have the form of an outgoing wave Ref [4]. In this scattering problem, it is understood that u identifies how the radiation of the isolated source ϕ_i has been redistributed by the prolate spheroid Ref [5].

Therefore the total outside solution according to Ref [1] is given by

$$\psi_{out} = \phi_i + u \quad (1.11)$$

1.4 Boundary Conditions

Analogous to equation 3 in Ref [1], the general boundary conditions will be used:

$$\begin{aligned} A\phi_i + u &= A'\psi_{in} ; A = A_1/A_3, A' = A_2/A_3, \\ B\partial_n\phi_i + \partial_n u &= B'\partial_n\psi_{in} ; B = B_1/B_3, B' = B_2/B_3, \end{aligned} \quad (1.12)$$

where A_i is the compressability of medium i and B_i is the inverse mass density of region i Ref [6]. The fields and their normal derivatives must be continuous at the surface of the scatterer, thus the boundary conditions are sometimes referred to as transition conditions Ref [4].

1.5 Scattering Amplitude

Analogous to Twersky's equation 4 in Ref [5], at large distances ($|r| \rightarrow \infty$) the scattered wave

$$u \sim {}_p g(\hat{\mathbf{o}}, \hat{\mathbf{i}}) {}_p h(r) \quad (1.13)$$

where ${}_p g$, the scattering amplitude due to the prolate spheroid is independent of r and ${}_p h(r)$, the new Hankle type function corresponding to the new scatterer, that is not equal to $e^{ikr}/(ikr)$ in three dimensions. However, due to the use of the prolate spheroidal coordinates, the scattering amplitude of this problem, while maintaining its operational form, will be quite different than in Ref [5]. The scattering amplitude will be used in reciprocity relations to obtain energy theorems for the problem Ref [7]. Even though the method used will follow Ref [5], Ref [6], Ref [7], the result will be those associated to the choice of the coordinate system appropriately used in this work. Energy theorems are generally associated with scattering cross section, absorption cross section, and total energy cross section which is the sum of the two.

Different functional forms for the scattered wave, u , will be derived Ref [1], Ref [7] using Green's Theorem. Both surface and volume integral representations of the scattered wave will form the basis of Twersky's "brace algebra" Ref [7]. The "brace algebra" will be fundamental to the derivation of the energy theorem.

1.6 Comparison to Twersky

With the correspondence principle as used to verify the results of quantum mechanics in the limits of classical mechanics Ref [8], the soft prolate spheroidal

scatterer will be collapsed to its spherical limit. This procedure will yield Twerky's appropriate result regarding a three dimensional spherical object Ref [7], Ref [9] and will serve as a means of verification for the new work.

CHAPTER 2

EXISTING RESULTS

In Ref [1], Ref [4], Ref [5], Ref [6], Ref [7], Ref [9], Twersky considered the problem for the scattering of a single object in isolation using spherical geometry. For completeness, a brief presentation of the important results needed for subsequent derivations will be provided here. For more details, the interested reader is advised to consult the literature and/or the references listed above.

2.1 Single Object in Isolation

We consider the scattering of plane incident wave $\phi_i = e^{i\mathbf{K}_1 \cdot \mathbf{r}} = e^{ik\eta\hat{\mathbf{i}} \cdot r\hat{\mathbf{o}}}$ by a penetrable sphere. See Figure 2.1.

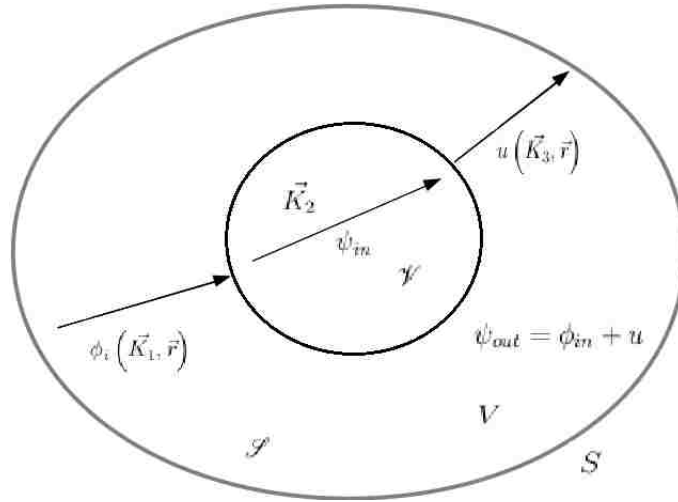

Figure 2.1: Visualization of the Three Media (Spherical)

The scatterer of volume \mathcal{V} , bounded by \mathcal{S} , is embedded in a medium contained in

volume V . The internal field, ψ_{in} , in the volume \mathcal{V} satisfies the differential equation $(\nabla^2 + K_2^2)\psi_{in} = 0$. The scattered wave, u , also satisfies the differential equation $(\nabla^2 + K_3^2)u = 0$. As in references Ref [1], Ref [2], Ref [5], Ref [6], Ref [7], Ref [9], the interior field is regular at the origin of coordinates which is the center of the scatterer. The scattered wave is bounded and also satisfies the Sommerfeld radiation condition of equation 1.10.

This thesis is looking for power series solutions. To obtain such solutions, the Helmholtz equation must be solved in the three different media defining the scattering problem. The method of choice is separation of variables.

2.2 Separation of Variables

In this section, a general solution of the Helmholtz equation is constructed.

Written in spherical polar coordinates (r, θ, ϕ) , it took the form

$$\frac{1}{r^2} \frac{\partial}{\partial r} \left(r^2 \frac{\partial \psi(\mathbf{r})}{\partial r} \right) + \frac{1}{r^2 \sin \theta} \frac{\partial}{\partial \theta} \left(\sin \theta \frac{\partial \psi(\mathbf{r})}{\partial \theta} \right) + \frac{1}{r^2 \sin^2 \theta} \frac{\partial^2 \psi(\mathbf{r})}{\partial \phi^2} + K^2 \psi(\mathbf{r}) = 0. \quad (2.1)$$

In equation 2.1, ψ represents ϕ_i , ψ_{in} and u , respectively for K_1 , K_2 and K_3 . ψ is assumed to be the product,

$$\psi(r, \theta, \phi) = R(r) \Theta(\theta) \Phi(\phi). \quad (2.2)$$

Divide both sides of equation 2.1 by $R\Theta\Phi$ to yield

$$\frac{1}{r^2 R} \frac{d}{dr} \left(r^2 \frac{dR}{dr} \right) + \frac{1}{r^2 \Theta \sin \theta} \frac{d}{d\theta} \left(\sin \theta \frac{d\Theta}{d\theta} \right) + \frac{1}{r^2 \Phi \sin^2 \theta} \frac{d^2 \Phi}{d\phi^2} + K^2 = 0. \quad (2.3)$$

In order to isolate the ϕ -dependence, multiply both sides of equation 2.3 by $r^2 \sin^2 \theta$ and rearrange terms, giving

$$\frac{1}{\Phi} \frac{d^2 \Phi}{d\phi^2} = r^2 \sin^2 \theta \left(-K^2 - \frac{1}{r^2 R} \frac{d}{dr} \left(r^2 \frac{dR}{dr} \right) - \frac{1}{r^2 \Theta \sin \theta} \frac{d}{d\theta} \left(\sin \theta \frac{d\Theta}{d\theta} \right) \right). \quad (2.4)$$

The left-hand side of equation 2.4 depends on ϕ , while the right-hand side is independent of ϕ . Therefore both sides of equation 2.4 are equal to a constant, $-m^2 \in \mathbb{R}$.

Thus

$$\frac{1}{\Phi} \frac{d^2 \Phi}{d\phi^2} = -m^2. \quad (2.5)$$

Use the substitution defined by equation 2.5 to rewrite equation 2.3 in terms of the separation constant, $-m^2$:

$$\frac{1}{r^2 R} \frac{d}{dr} \left(r^2 \frac{dR}{dr} \right) + \frac{1}{r^2 \Theta \sin \theta} \frac{d}{d\theta} \left(\sin \theta \frac{d\Theta}{d\theta} \right) - \frac{m^2}{r^2 \sin^2 \theta} + K^2 = 0. \quad (2.6)$$

Multiply both sides of equation 2.6 by r^2 and rearrange terms in order to isolate the θ -dependence:

$$\frac{1}{\Theta \sin \theta} \frac{d}{d\theta} \left(\sin \theta \frac{d\Theta}{d\theta} \right) - \frac{m^2}{\sin^2 \theta} = -\frac{1}{R} \frac{d}{dr} \left(r^2 \frac{dR}{dr} \right) - K^2 r^2. \quad (2.7)$$

The left-hand side of equation 2.7 depends on θ , while the right-hand side is independent of θ . Again both sides of equation 2.7 equal a constant, $l(l+1) \in \mathbb{R}$. The remaining separated equations are

$$\frac{1}{\sin \theta} \frac{d}{d\theta} \left(\sin \theta \frac{d\Theta}{d\theta} \right) - \frac{m^2}{\sin^2 \theta} \Theta + l(l+1) \Theta = 0, \quad (2.8)$$

and

$$r^2 \frac{d^2 R}{dr^2} + 2r \frac{dR}{dr} + (K^2 r^2 - l(l+1)) R = 0. \quad (2.9)$$

2.2.1 Azimuthal Equation

Equation 2.5 involves the azimuthal angle ϕ and the separation constant $-m^2$:

$$\frac{d^2\Phi(\phi)}{d\phi^2} + m^2\Phi(\phi) = 0. \quad (2.10)$$

For every $m \in \mathbb{R}$, equation 2.10 admits solutions

$$\Phi_m(\phi) = \frac{1}{\sqrt{2\pi}} e^{im\phi}, \quad (2.11)$$

and

$$\Phi_{-m}(\phi) = \frac{1}{\sqrt{2\pi}} e^{-im\phi}. \quad (2.12)$$

Because the solutions of equation 2.10 must be single-valued, they satisfy a periodicity condition:

$$\Phi_{\pm m}(\phi + 2\pi) = \Phi_{\pm m}(\phi), \quad \phi \in [0, 2\pi]. \quad (2.13)$$

For $\phi = 0$, equation 2.13 becomes

$$\Phi_{\pm m}(2\pi) = \Phi_{\pm m}(0), \quad (2.14)$$

or, equivalently,

$$e^{\pm 2\pi mi} = 1. \quad (2.15)$$

We conclude that m is an integer ($m \in \mathbb{Z}$).

Let \mathcal{M} be a set of functions defined by

$$\mathcal{M} = \{\Phi_n | n \in \mathbb{Z}\}. \quad (2.16)$$

The collection \mathcal{M} forms a basis for the Hilbert space $L^2([0, 2\pi])$ of all complex-valued functions on $[0, 2\pi]$ with finite Lebesgue measure Ref [10]. This basis satisfies an orthogonality condition:

$$\int_0^{2\pi} \Phi_p(\phi)^* \Phi_q(\phi) d\phi = \delta_{p,q}, \quad p, q \in \mathbb{Z}. \quad (2.17)$$

2.2.2 Polar Equation

Equation 2.8 involves the polar angle θ , the separation constants $-m^2$, and $l(l+1)$:

$$\frac{1}{\sin \theta} \frac{d}{d\theta} \left(\sin \theta \frac{d\Theta}{d\theta} \right) + \left(l(l+1) - \frac{m^2}{\sin^2 \theta} \right) \Theta = 0. \quad (2.18)$$

Temporarily, x is used to denote an arbitrary real or complex value, not the first component of the position vector $\mathbf{r} = (x, y, z) \in \mathbb{R}^3$. Consider the substitution

$$x = \cos \theta. \quad (2.19)$$

By the chain rule, we have

$$\frac{d}{d\theta} = -\sin \theta \frac{d}{dx}. \quad (2.20)$$

Working with equations 2.19 and 2.20, equation 2.18 is written in a standard form:

$$(1-x^2) \frac{d^2\Theta}{dx^2} - 2x \frac{d\Theta}{dx} + \left(l(l+1) - \frac{m^2}{1-x^2} \right) \Theta = 0. \quad (2.21)$$

Equation 2.21 is the associated Legendre equation, admitting solutions designated as associated Legendre polynomials of the first kind,

$$P_l^m(x) = (-1)^m (1-x^2)^{m/2} \frac{d^m}{dx^m} P_l(x) \quad (2.22)$$

and associated Legendre functions of the second kind, which are not of any use in the scattering problem Ref [11].

We require solutions of equation 2.21 to be finite on the closed interval $[-1, 1]$. As demonstrated by Ref [11] on page 98 the finiteness requirement demands that $l \in \mathbb{Z}$ with $l \geq 0$. In our discussion of the azimuthal equation in Subsection 2.2.1, we established that $m \in \mathbb{Z}$. Let \mathcal{P} be a set of functions defined by

$$\mathcal{P} = \{P_l^m | l, m \in \mathbb{Z}, 0 \leq |m| \leq l\}. \quad (2.23)$$

The collection \mathcal{P} forms a basis for the Hilbert space $L^2([-1, 1])$. This basis satisfies an orthogonality condition:

$$\int_{-1}^1 P_l^m(x) P_{l'}^m(x) dx = \frac{2}{2l+1} \frac{(l+m)!}{(l-m)!} \delta_{l,l'}, \quad l, l' \in \mathbb{Z}. \quad (2.24)$$

The reader may consult Ref [10] page 727 for the manner in which the normalization constant from equation 2.24 was found. The associated Legendre function P_l^m is related to the Legendre functions P_l by the following property:

For all $l \in \mathbb{Z}$ with $l \geq 0$,

$$P_l^0(x) = P_l(x), \quad x \in \mathbb{R}. \quad (2.25)$$

As a special case of equation 2.24, for $m = 0$, we have an orthogonality condition for the Legendre functions:

$$\int_{-1}^1 P_l(x) P_{l'}(x) dx = \frac{2}{2l+1} \delta_{l,l'}, \quad l, l' \in \mathbb{Z}, l, l' \geq 0. \quad (2.26)$$

2.2.3 Radial Equation

Equation 2.9 involves the radial coordinate r , the separation constant $l(l+1)$, and the wave number K :

$$r^2 \frac{d^2 R}{dr^2} + 2r \frac{dR}{dr} + (K^2 r^2 - l(l+1)) R = 0. \quad (2.27)$$

If we let $\rho = Kr$, then

$$\frac{d}{dr} = K \frac{d}{d\rho} \quad (2.28)$$

and

$$\frac{d^2}{dr^2} = K^2 \frac{d^2}{d\rho^2}. \quad (2.29)$$

Using substitutions 2.28 and 2.29, equation 2.27 becomes

$$\rho^2 \frac{d^2 R}{d\rho^2} + 2\rho \frac{dR}{d\rho} + (\rho^2 - l(l+1)) R = 0, \quad (2.30)$$

where $R(\rho) = R(Kr)$. The spherical Bessel equations 2.27 and 2.30 have two solutions, $j_l(\rho) = j_l(Kr)$ and $n_l(\rho) = n_l(Kr)$. $j_l(\rho)$ is regular at the origin while $n_l(\rho)$ has a logarithmic singularity. However for this problem we are going to use the Hankel function $h_l^{(1)} = h_l$, the spherical Hankel function of the first kind, where $h_l = j_l + in_l$. The functions $h_l(\rho)$, $j_l(\rho)$ and $n_l(\rho)$ are given in Ref [3], Ref [10] and Ref [11].

2.2.4 Series Solutions

In spherical coordinates, j_n , h_n , and P_n denote, respectively, the spherical Bessel function of the first kind, Hankel function of the first kind, and the Legen-

dre polynomial. Expanding as in Ref [3] the incident plane wave ϕ_i we obtain

$$\phi_i(\mathbf{r}) = \sum_{n=0}^{+\infty} i^n (2n+1) j_n(K_1 r) P_n(\cos\theta) \quad \text{Ref [11]}. \quad (2.31)$$

Similar to equation 2.31 the power series solution of the internal field is given by

$$\psi_{in}(\mathbf{r}) = \sum_{n=0}^{+\infty} i^n (2n+1) b_n j_n(K_2 r) P_n(\cos\theta) \quad (2.32)$$

where the second solution of the spherical Bessel, n_n , is missing due to the regularity at the origin of coordinates which is the center of the sphere. Analogous to equations 2.31 and 2.32 the scattered wave is represented by

$$u(\mathbf{r}) = \sum_{n=0}^{+\infty} i^n (2n+1) c_n h_n(K_3 r) P_n(\cos\theta). \quad (2.33)$$

The presence of the Hankel function, $h_n = j_n + in_n$, is because r is large. These are general functional forms of the interior field and the scattered wave. To determine the coefficients of expansion b_n and c_n , transition conditions are applied at the surface for the soft scatterer.

2.3 Transition Conditions

In spherical polar coordinates, the gradient $\nabla\psi$ can be written as a linear combination of the orthonormal basis vectors $\{\hat{\mathbf{e}}_r, \hat{\mathbf{e}}_\theta, \hat{\mathbf{e}}_\phi\}$:

$$\nabla\psi = \frac{1}{h_r} \frac{\partial\psi}{\partial r} \hat{\mathbf{e}}_r + \frac{1}{h_\theta} \frac{\partial\psi}{\partial\theta} \hat{\mathbf{e}}_\theta + \frac{1}{h_\phi} \frac{\partial\psi}{\partial\phi} \hat{\mathbf{e}}_\phi \quad (2.34)$$

where $h_r = 1$, $h_\theta = r$ and $h_\phi = r \sin \theta$ Ref [12]. The normal derivative may be expressed as

$$\begin{aligned}
\hat{\mathbf{n}} \cdot \nabla \psi &= \hat{\mathbf{e}}_r \cdot \nabla \psi \\
&= \hat{\mathbf{e}}_r \cdot \left(\frac{1}{h_r} \frac{\partial \psi}{\partial r} \hat{\mathbf{e}}_r + \frac{1}{h_\theta} \frac{\partial \psi}{\partial \theta} \hat{\mathbf{e}}_\theta + \frac{1}{h_\phi} \frac{\partial \psi}{\partial \phi} \hat{\mathbf{e}}_\phi \right) \\
&= \frac{1}{h_r} \frac{\partial \psi}{\partial r} \\
&= \frac{\partial \psi}{\partial r}.
\end{aligned} \tag{2.35}$$

Motivated by the Transition Conditions provided in and similar to equation 13 of Ref [1], equations 1.12 lead to:

$$\begin{aligned}
A_1 \psi_1(\mathbf{r}) + A_3 u(\mathbf{r}) &= A_2 \psi_2(\mathbf{r}) \quad \text{at } r = a, \\
\sum_{n=0}^{+\infty} i^n (2n+1) P_n(\cos \theta) [A_1 j_n(K_1 a) + A_3 c_n h_n(K_3 a)] \\
&= \sum_{n=0}^{+\infty} i^n (2n+1) P_n(\cos \theta) A_2 b_n j_n(K_2 a)
\end{aligned} \tag{2.36}$$

and

$$\begin{aligned}
B_1 \hat{\mathbf{n}} \cdot \nabla \psi_1(\mathbf{r}) + B_3 \hat{\mathbf{n}} \cdot \nabla u(\mathbf{r}) &= B_2 \hat{\mathbf{n}} \cdot \nabla \psi_2(\mathbf{r}) \quad \text{at } r = a, \\
\sum_{n=0}^{+\infty} i^n (2n+1) P_n(\cos \theta) [K_1 B_1 j_n'(K_1 a) + K_3 B_3 c_n h_n'(K_3 a)] \\
&= \sum_{n=0}^{+\infty} i^n (2n+1) P_n(\cos \theta) K_2 B_2 b_n j_n'(K_2 a).
\end{aligned} \tag{2.37}$$

Simplifying the equations 2.36 and 2.37 using orthogonality we obtain

$$A_1 j_n(K_1 a) + A_3 c_n h_n(K_3 a) = A_2 b_n j_n(K_2 a) \tag{2.38}$$

and

$$K_1 B_1 j_n'(K_1 a) + K_3 B_3 c_n h_n'(K_3 a) = K_2 B_2 b_n j_n'(K_2 a). \tag{2.39}$$

The system of linear equations, equations 2.38 and 2.39, is solved to obtain the coefficients,

$$b_n = \frac{1}{\Delta_n} [kA j_n(Ka) h'_n(ka) - KB h_n(ka) j'_n(Ka)], \quad (2.40)$$

$$c_n = \frac{1}{\Delta_n} [AK' B' j_n(Ka) j'_n(K'a) - A' KB j_n(K'a) j'_n(Ka)], \quad (2.41)$$

where

$$\Delta_n = kA' j_n(K'a) h'_n(ka) - K' B' h_n(ka) j'_n(K'a), \quad (2.42)$$

$$A = \frac{A_1}{A_3}, \quad A' = \frac{A_2}{A_3}, \quad B = \frac{B_1}{B_3}, \quad B' = \frac{B_2}{B_3}, \quad K = K_1, \quad K' = K_2, \quad k = K_3. \quad (2.43)$$

2.4 Radiation Condition

We now verify that the series for u from equation 2.33 satisfies the Sommerfeld radiation condition, equation 1.10. We use the expression for the directional derivative from equation 2.35 in order to write the radiation condition in spherical polar coordinates:

$$\lim_{r \rightarrow +\infty} \left[r \frac{\partial u(\mathbf{r})}{\partial r} - iK_3 r u(\mathbf{r}) \right] = 0. \quad (2.44)$$

Using the general solution for u from equation 2.33, the radiation condition becomes

$$\lim_{r \rightarrow +\infty} \left[K_3 r \sum_{n=0}^{+\infty} i^n (2n+1) c_n \mathbf{P}_n(\cos \theta) [h'_n(K_3 r) - i h_n(K_3 r)] \right] = 0. \quad (2.45)$$

The asymptotic value of $h_n(x)$ as $x \rightarrow +\infty$ is given by

$$h_n(x) \sim (-i)^{n+1} \frac{e^{ix}}{x}, \quad x \gg \frac{n(n+1)}{2} \quad \text{Ref [10]}. \quad (2.46)$$

The spherical Hankel function, h_n , satisfies a recurrence relation,

$$nh_{n-1}(x) - (n+1)h_{n+1}(x) = (2n+1)h'_n(x) \quad \text{Ref [10].} \quad (2.47)$$

We isolate $h'_n(x)$ from equation 2.47 to get

$$h'_n(x) = \frac{n}{2n+1}h_{n-1}(x) - \frac{n+1}{2n+1}h_{n+1}(x). \quad (2.48)$$

Using the asymptotic behavior of h_n given by equation 2.46, combined with equation 2.48, we find the asymptotic behavior of $h'_n(x)$ as $x \rightarrow +\infty$:

$$\begin{aligned} h'_n(x) &\sim (-i)^n \frac{n}{2n+1} \frac{e^{ix}}{x} - (-i)^{n+2} \frac{n+1}{2n+1} \frac{e^{ix}}{x} \\ &= (-i)^n \frac{e^{ix}}{x}, \quad x \gg \frac{(n+1)(n+2)}{2}. \end{aligned} \quad (2.49)$$

Given the fact that the limit is over r as $r \rightarrow \infty$, equation 2.45 simplifies to

$$\lim_{r \rightarrow +\infty} r (h'_n(K_3r) - ih_n(K_3r)) = 0. \quad (2.50)$$

Using the asymptotic behavior of h_n and h'_n from equations 2.46 and 2.49, we obtain

$$\begin{aligned} r (h'_n(K_3r) - ih_n(K_3r)) &\sim (-i)^n \frac{e^{iK_3r}}{K_3r} - i(-i)^{n+1} \frac{e^{iK_3r}}{K_3r} \\ &= r \left((-i)^n \frac{e^{iK_3r}}{K_3r} + (-i)^{n+2} \frac{e^{iK_3r}}{K_3r} \right) \\ &= 0. \end{aligned} \quad (2.51)$$

Equation 2.51 confirms that equation 2.50 is a true statement since $(-i)^{n+2} = -(-i)^n$.

Thus u satisfies the radiation condition.

2.5 Green's Function Representation

To derive the surface and volume integral of the scattered wave and establish Twersky's "brace algebra," it is convenient to use equations 22 and 23 of Ref [1].

In addition to the convenience, two different forms of the scattered wave will be considered. Equation 22 is the well-known divergence theorem and equation 23 is Green's Identity expressed as

$$\oint (\mathcal{G}\nabla u - u\nabla\mathcal{G}) \cdot d\vec{S} = \int (\mathcal{G}\nabla^2 u - u\nabla^2\mathcal{G}) dV. \quad (2.52)$$

Recall that $d\vec{S}$ is $\hat{\mathbf{n}} \cdot dS$ and $\hat{\mathbf{n}} \cdot \nabla = \partial_n$ and $\hat{\mathbf{n}}$ is the outward unit normal. With the information above, equation 2.52 is transformed into

$$\oint (\mathcal{G}\partial_n u - u\partial_n\mathcal{G}) dS = \int (\mathcal{G}\nabla^2 u - u\nabla^2\mathcal{G}) dV. \quad (2.53)$$

\mathcal{G} , the Green's Function, is the fundamental or distributional solution of the generalized reduced wave equation

$$(\nabla^2 + K_3^2) \mathcal{G} \left(|\vec{r} - \vec{r}'| \right) = \delta \left(\vec{r} - \vec{r}' \right). \quad (2.54)$$

The work was conducted in spherical coordinates. The Green's Function is known as

$$\mathcal{G} = \frac{h_0^{(1)} \left(k |\vec{r} - \vec{r}'| \right)}{4\pi i/k} \quad \text{Ref [1]}. \quad (2.55)$$

To proceed equation 2.53 must be simplified with the knowledge of $\nabla^2 u$ and $\nabla^2\mathcal{G}$. From equation 1.9 $\nabla^2 u = -K_3^2 u$ and from equation 2.54, $\nabla^2\mathcal{G} = -K_3^2\mathcal{G} + \delta$. Using the facts above in equation 2.53 recalling from Chapter 1, $K_3 = k$, yields

$$\begin{aligned} & \oint \left(\mathcal{G} \left(k |\vec{r} - \vec{r}'| \right) \partial_n u(kr') - u(kr') \partial_n \mathcal{G} \left(k |\vec{r} - \vec{r}'| \right) \right) dS \left(\vec{r} - \vec{r}' \right) \\ & = - \int \mathcal{G} \left(k |\vec{r} - \vec{r}'| \right) k^2 u dV - \int u \left(kr' \right) \left(-k^2 \mathcal{G} \left(k |\vec{r} - \vec{r}'| \right) + \delta \left(\vec{r} - \vec{r}' \right) \right) dV. \end{aligned} \quad (2.56)$$

Observing Figure 2.1, note there are two surfaces and two volumes to be considered,

$$V = \mathcal{V} + V_\infty \text{ and } S = \mathcal{S} + S_\infty. \quad (2.57)$$

At infinity, Sommerfield radiation conditions of equation 1.10 are used on the Green's function, \mathcal{G} , to eliminate the corresponding contributions from both surface and volume integrals. With these changes implemented, equation 2.56 becomes

$$\begin{aligned} \oint \left(\mathcal{G} \left(k \left| \vec{r} - \vec{r}' \right| \right) \partial_n u(k\vec{r}') - u(k\vec{r}') \partial_n \mathcal{G} \left(k \left| \vec{r} - \vec{r}' \right| \right) \right) d\mathcal{S} \left(-\vec{r}' \right) \\ = - \int u \left(k\vec{r}' \right) \delta \left(\vec{r} - \vec{r}' \right) d\mathcal{V}. \end{aligned} \quad (2.58)$$

There are three issues to be considered:

- (1) $d\mathcal{S} \left(-\vec{r}' \right) = - d\mathcal{S} \left(\vec{r}' \right)$
- (2) The right hand side of equation 2.58 is the generalized operator in the sense of a distribution (Ref[11] page 29, equation sub 3 in describing the proportions of the delta function), is the value of the function evaluated at the singularity.
- (3) $\int u \left(k\vec{r}' \right) \delta \left(\vec{r} - \vec{r}' \right) d\mathcal{V} = u \left(k\vec{r}' \right)$.

Now the surface integral representation of the scattered wave is given by

$$u \left(k\vec{r}' \right) = \oint \left(\mathcal{G} \left(k \left| \vec{r} - \vec{r}' \right| \right) \partial_n u(k\vec{r}') - u(k\vec{r}') \partial_n \mathcal{G} \left(k \left| \vec{r} - \vec{r}' \right| \right) \right) d\mathcal{S} \left(\vec{r}' \right). \quad (2.59)$$

Equation 2.59 permits us to evaluate the scattered wave at an observation point far removed from the surface of the scatterer, from the knowledge (measurement) of the scattered solution at the surface. A volume integral equation, similar to equation

2.59, can be obtained by using again Green's identity and the transition of equation 1.12. For the scope of this thesis, equation 2.59 will suffice.

For the sake of generality and subsequent developments, replace the scattered solution, $u(k\vec{r}')$, by the incident wave, ϕ_i , in equation 2.59 to obtain the zero solution for \vec{r} outside the surface of the scatterer since the incident wave is regular over the entire space Ref[7]. Equation 2.59 can be written in its operator form

$$u(k\vec{r}) = \left\{ \mathcal{G} \left(k \left| \vec{r} - \vec{r}' \right| \right), u(k\vec{r}') \right\}. \quad (2.60)$$

To simplify notation and introduce functional forms ready for applications let $\mathcal{G}(k|\vec{r} - \vec{r}'|) = h_0(k|\vec{r} - \vec{r}'|)$ and as in Section 1 of Chapter 1, $\vec{r} = r\hat{o}$ and $\vec{k} = k\hat{i}$. That is to say, \hat{i} and \hat{o} represent respectively the directions of incidence and observation. Therefore, as in Ref[9] Equation 4, equation 2.59 is transformed into

$$u(k\hat{o}, \hat{i}) = \left\{ h_0 \left(k \left| \vec{r} - \vec{r}' \right| \right), u(\vec{r}', \hat{i}) \right\}. \quad (2.61)$$

Hence, the scattered wave can be written in terms of the total outside solution

$$u(k\hat{o}, \hat{i}) = \left\{ h_0 \left(k \left| \vec{r} - \vec{r}' \right| \right), \psi_{out}(\vec{r}', \hat{i}) \right\} \quad (2.62)$$

where ψ_{out} is given in equation 1.11.

2.6 Scattering Amplitude

For large distance, $\vec{r} \gg \vec{r}'$, the asymptotic form $h_0(k|\vec{r} - \vec{r}'|)$ given in equation 30 of Ref[1] is used in equation 2.61 to obtain

$$u(k\hat{o}, \hat{i}) \sim \left\{ ch(kr)e^{-ik\hat{o}\cdot\vec{r}'} , u(\vec{r}', \hat{i}) \right\}. \quad (2.63)$$

For the spherical geometry $c = \frac{k}{4i\pi}$ and $h = \frac{e^{ikr}}{ikr}$. In equation 2.63 the integration at the surface of the scatterer is over \vec{r}' . Therefore, equation 2.63 can be written as

$$u(k\hat{o}, \hat{i}) \sim c \frac{e^{ikr}}{ikr} \left\{ e^{-ik\hat{o}\cdot\vec{r}'} , u(\vec{r}', \hat{i}) \right\} \quad (2.64)$$

which is

$$u(k\hat{o}, \hat{i}) \sim h(k\vec{r}') g(k\hat{o}, K_1\hat{i}). \quad (2.65)$$

In equation 2.65, $h(k\vec{r}')$ is the spherical Hankel function of the first kind and $g(k\hat{o}, K_1\hat{i})$ is the scattering amplitude, given as

$$\begin{aligned} g(k\hat{o}, K_1\hat{i}) &= c \left\{ e^{-ik\hat{o}\cdot\vec{r}'} , u(\vec{r}', \hat{i}) \right\} \\ &= c \int \left[e^{-ik\hat{o}\cdot\vec{r}'} \partial_n u(\vec{r}', \hat{i}) - u(\vec{r}', \hat{i}) \partial_n e^{-ik\hat{o}\cdot\vec{r}'} \right] d\mathcal{S}(\vec{r}'). \end{aligned} \quad (2.66)$$

The scattering amplitude $g(k\hat{o}, K_1\hat{i})$ can be interpreted as the response of the scatterer to the impinging incident wave. Equation 2.65 is fundamental to the solution of the scattering problem. Notice that the incident wave is known and the Hankel functions are tabulated in Ref[14]. To obtain the scattered wave, $u(k\hat{o}, \hat{i})$, it is sufficient to know $g(k\hat{o}, K_1\hat{i})$ which is a function of angles. Again, a volume integral

formulation for the scattering amplitude can be obtained using the transition conditions and divergence theorem of equation 2.53. The surface integral representation of the scattering amplitude $g(k\hat{o}, K_1\hat{i})$ is again sufficient for this thesis.

2.7 Reciprocity Relation and Energy Theorem

2.7.1 Reciprocity Relation

To establish the reciprocity relation as in Ref[7], two different total outside solutions are required here. The two solutions satisfy the same transition conditions at the surface of the scatterer. Let the two solutions be ψ_1 due to the incident wave ϕ_1 and ψ_2 due to the incident wave ϕ_2 . Their corresponding propagation vectors are \vec{K}_1 and \vec{K}_2 . ψ_1 and ψ_2 take the following forms

$$\psi_1 = \phi_1 + u_1 \text{ and } \psi_2 = \phi_2 + u_2. \quad (2.67)$$

At the surface of the scatterer,

$$\{\psi_1, \psi_2\} = 0. \quad (2.68)$$

Substituting equations 2.67 into equation 2.68 leads to

$$\{\phi_1 + u_1, \phi_2 + u_2\} = 0. \quad (2.69)$$

The linearity of the operator allows the following

$$\{\phi_1, \phi_2\} + \{\phi_1, u_2\} + \{u_1, \phi_2\} + \{u_1, u_2\} = 0. \quad (2.70)$$

At the surface of the scatterer the first and fourth term of equation 2.70 must vanish

$$\{\phi_1, \phi_2\} = s_\infty \{u_1, u_2\} = 0. \quad (2.71)$$

Notice that the incident waves have no singularities. The scattered waves, u_1, u_2 , must satisfy the Somerfeld Radiative condition at infinity. Hence, it has no contribution. Therefore equation 2.70 is transformed into

$$\{\phi_1, u_2\} + \{u_1, \phi_2\} = 0 \quad (2.72)$$

or

$$\{\phi_1, u_2\} = -\{u_1, \phi_2\} = \{\phi_2, u_1\}. \quad (2.73)$$

The general form of the reciprocity relation is

$$\{\phi_1, u_2\} = \{\phi_2, u_1\}. \quad (2.74)$$

Returning to the surface integral, equation 2.74 is written as

$$\begin{aligned} & \oint \left[e^{iK_1 \cdot \vec{r}'} \partial_n u_2(K_2 \vec{r}') - u_2(K_2 \vec{r}') \partial_n e^{iK_1 \cdot \vec{r}'} \right] d\mathcal{S}(\vec{r}') \\ &= \oint \left[e^{iK_2 \cdot \vec{r}'} \partial_n u_1(K_1 \vec{r}') - u_1(K_1 \vec{r}') \partial_n e^{iK_2 \cdot \vec{r}'} \right] d\mathcal{S}(\vec{r}'). \end{aligned} \quad (2.75)$$

What is missing to recover the scattering amplitude is a negative in the argument in the exponential. Utilizing the fact that $e^{\vec{i}K_1 \cdot \vec{r}'} = e^{-i(-K_1 \cdot \vec{r}')}$, equation 2.75

$$g(-\hat{K}_1, \hat{K}_2) = g(-\hat{K}_2, \hat{K}_1) \quad (2.76)$$

as in Ref[4], the two directions of incidence are represented by vectors $\vec{K}_1 = K_1 \hat{K}_1$ and $\vec{K}_2 = K_2 \hat{K}_2$.

2.7.2 Energy Theorem

Replacing ψ_1 with ψ_1^* in equation 2.68, where ψ_1^* is the complex conjugate of ψ_1 in equation 2.67, leads to

$$\begin{aligned} \{\psi_1^*, \psi_2\} &= \{\phi_1^* + u_1^*, \phi_2 + u_2\} \\ &= \{\phi_1^*, \phi_2\} \\ &\quad + \{\phi_1^*, u_2\} \\ &\quad + \{u_1^*, \phi_2\} \\ &\quad + \{u_1^*, u_2\} \\ &= 0. \end{aligned} \quad (2.77)$$

As shown before in equation 2.71 $\{\phi_1^*, \phi_2\} = 0$, therefore equation 2.77 reduces to

$$\{\phi_1^*, u_2\} + \{u_1^*, \phi_2\} = -\{u_1^*, u_2\} \quad (2.78)$$

The right hand side of equation 2.78 is given in Ref[4] equation 10 as

$$\{u_1^*, u_2\} = 2M \left[g^*(\hat{o}, \hat{K}_1) g(\hat{o}, \hat{K}_2) \right] \quad (2.79)$$

where

$$M = \frac{1}{4\pi} \int_0^{2\pi} d\phi \int_0^\pi \sin(\theta) d\theta.$$

The first term on the left hand side of equation 2.78 is the scattering amplitude defined in equation 2.66,

$$\{\phi_1^*, u_2\} = \{e^{-i\hat{K}_1 \cdot \hat{K}_2 \cdot \vec{r}^j}, u_2\} = g(\hat{K}_1, \hat{K}_2). \quad (2.80)$$

The second term on the left hand side of equation 2.78

$$\{\phi_1^*, u_2\} = -\{\phi_2, u_1^*\}. \quad (2.81)$$

Recall the definition in equation 2.66

$$g(\hat{K}_2, \hat{K}_1) = \{e^{-i\hat{K}_1 \cdot \hat{K}_2 \cdot \vec{r}^j}, u_1(\hat{K}_1 \vec{r}^j)\}. \quad (2.82)$$

Taking the complex conjugate of equation 2.82 leads to

$$\begin{aligned}
g^*(\hat{K}_2, \hat{K}_1) &= \{e^{-i\hat{K}_1 \cdot \hat{K}_2 \cdot \vec{r}'} , u_1(\hat{K}_1 \vec{r}')\}^* & (2.83) \\
&= \{\phi_2, u_1^*\}^* \\
&= -\{\phi_2, u_1^*\}.
\end{aligned}$$

Therefore equation 2.78 becomes

$$-\left(g(\hat{K}_1, \hat{K}_2) + g^*(\hat{K}_2, \hat{K}_1)\right) = 2M \left[g^*(\hat{o}, \hat{K}_1)g(\hat{o}, \hat{K}_2)\right] \quad (2.84)$$

which is the general form of the Energy Theorem. In the case where $\hat{K}_1 = \hat{K}_2 = \hat{K}$ equation 2.84 becomes

$$-\left(g(\hat{K}, \hat{K}) + g^*(\hat{K}, \hat{K})\right) = 2M \left[g^*(\hat{o}, \hat{K})g(\hat{o}, \hat{K})\right]. \quad (2.85)$$

Simplifying equation 2.85 gives, as in Ref[4] and Ref[7],

$$-\text{Re}(g(\hat{K}, \hat{K})) = M|g(\hat{o}, \hat{k})|^2 = \frac{1}{2}\{u^*, u\} = \frac{\sigma_s}{\sigma_0} \quad (2.86)$$

where σ_s is the scattering cross section and $\sigma_0 = \frac{4\pi}{K^2}$. Equation 2.86 is referred to as the Optical Theorem in Ref[11].

CHAPTER 3

PLANE WAVE SCATTERING BY SOFT PROLATE SPHEROIDS

3.1 Overview of a Prolate Spheroid

The work done in this chapter is an extension to prolate spheroidal geometry Ref [13] (see Figure 3.1 and Figure 3.2) of Twersky's research in Ref [1], Ref [5], Ref [6], Ref [7], Ref [9] associated to spherical domains (see Figure 3.3). To provide a better understanding and clarity of purpose it would be convenient to succinctly describe the geometry at work.

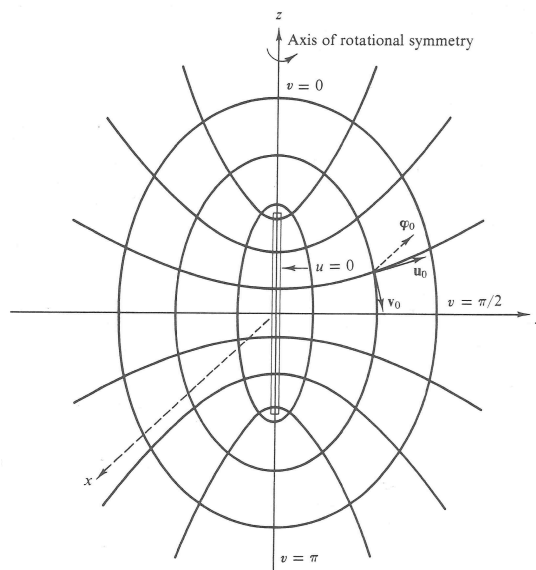

Figure 3.1: Prolate Spheroid

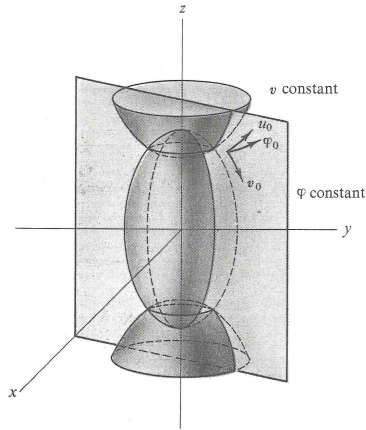

Figure 3.2: Prolate Spheroid

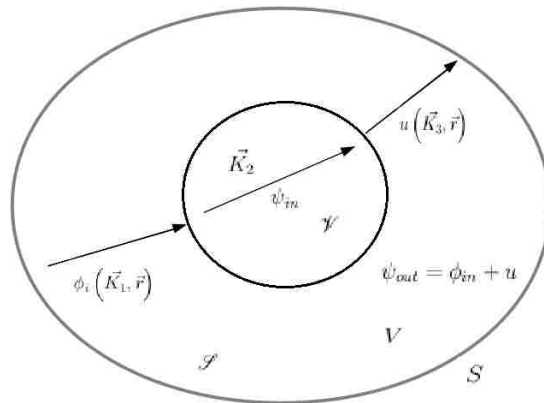

Figure 3.3: Visualization of the Three Media (Spherical)

3.2 Definition of a Prolate Spheroid

To establish a working definition of the prolate spheroidal coordinate system this thesis begins with the consideration of elliptic cylindrical coordinates described in Ref [13] (see Figure 3.4).

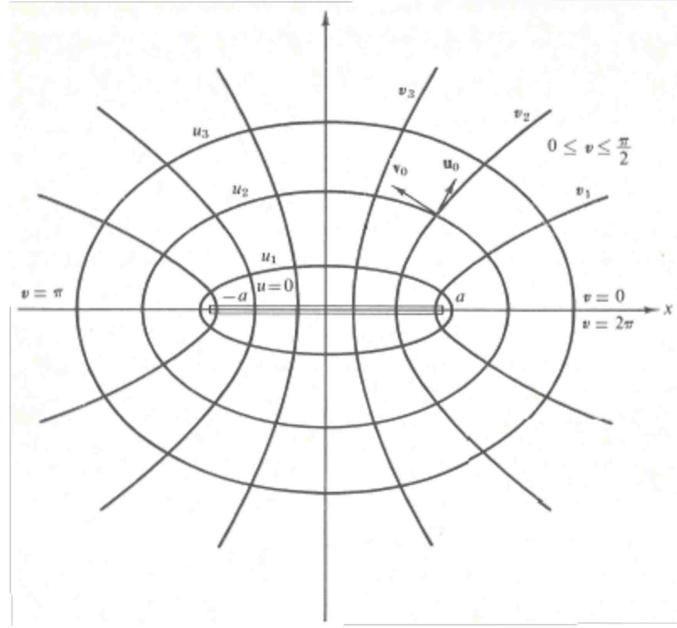

Figure 3.4: Elliptic Cylindrical Coordinates

Elliptic cylindrical coordinates are given in Ref [13] equation 2.73 as

$$\begin{aligned}
 x &= a \cosh u \cos v, \\
 y &= a \sinh u \sin v, \\
 z &= z,
 \end{aligned}
 \tag{3.1}$$

where u is a bounded constant, $0 \leq u < \infty$ and a is the focal distance. If the interfocal distance d is used, then $a = \frac{d}{2}$. As can be identified in Figure 3.4 the major axis of the elliptic cylinder lies on the x-axis. Rotating the elliptic cylinder about its major axis, adding the azimuthal angle φ and using z as the axis of rotational symmetry

similar to Ref [13] equation 2.96 leads to the needed prolate spheroidal coordinates:

$$\begin{aligned}x &= a \sinh u \sin v \cos \varphi, \\y &= a \sinh u \sin v \sin \varphi, \\z &= a \cosh u \cos v,\end{aligned}\tag{3.2}$$

with $u \in [0, \infty)$, $v \in [0, \pi]$ and $\varphi \in [0, 2\pi)$. Analogous to Ref [13] equation 2.97, the scale factors are

$$\begin{aligned}h_1 &= a (\sinh^2 u + \sin^2 v)^{\frac{1}{2}}, \\h_2 &= a (\sinh^2 u + \sin^2 v)^{\frac{1}{2}}, \\h_3 &= a \sinh u \sin v.\end{aligned}\tag{3.3}$$

For convenience the scale factors can be written as h_u , h_v and h_φ respectively. Notice that Figure 3.1 is a visual representation of the transformation described above.

For a detailed review of the nature of the scale factors which express the ratio of differential distances to the differentials of the coordinate parameters when dealing with curvilinear coordinate systems, all interested readers are referred to Ref [3], [13], [15] and [16]. In addition, the scale factors collectively are identified as the metric Ref [13] equation 2.4,

$$ds^2 = dx^2 + dy^2 + dz^2 = \sum_{i,j} h_{ij}^2 dq_i dq_j.\tag{3.4}$$

Similar to Ref [16] equations 38 and 39

$$dv = \sqrt{g} du^1 du^2 du^3\tag{3.5}$$

and

$$g = \begin{vmatrix} g_{11} & g_{12} & g_{13} \\ g_{21} & g_{22} & g_{23} \\ g_{31} & g_{32} & g_{33} \end{vmatrix}, \quad (3.6)$$

display the same interpretation of the scale factors. For orthogonal coordinate systems ($g_{ij} = 0$ when $i \neq j$) the following abbreviations are used in Ref [16] equations 68 and 69,

$$h_1 = \sqrt{g_{11}}, \quad h_2 = \sqrt{g_{22}}, \quad h_3 = \sqrt{g_{33}}$$

$$g^{ii} = \frac{1}{g_{ii}} = \frac{1}{h_i^2}. \quad (3.7)$$

Recall that the coordinate system used in this chapter, prolate spheroidal, is an orthogonal system.

To introduce forms ready for application, equation 3.2 is modified by the following transformations:

$$\begin{aligned} \xi &= \cosh u, \\ \eta &= \cos v, \\ \phi &= \varphi, \\ c &= a, \end{aligned} \quad (3.8)$$

where $\xi \in [1, \infty)$, $\eta \in [-1, 1]$, and $\phi \in [0, 2\pi)$ Ref [14]. Equation 3.8 is substituted into equation 3.2, the fundamental identity for hyperbolic functions is used to obtain

$$\begin{aligned} x &= c\sqrt{(\xi^2 - 1)(1 - \eta^2)} \cos \phi, \\ y &= c\sqrt{(\xi^2 - 1)(1 - \eta^2)} \sin \phi, \\ z &= c\xi\eta, \end{aligned} \quad (3.9)$$

with transformed associated scale factors of equation 3.3 expressed by

$$\begin{aligned} h_\xi &= c\sqrt{\frac{\xi^2 - \eta^2}{\xi^2 - 1}}, \\ h_\eta &= c\sqrt{\frac{\xi^2 - \eta^2}{1 - \eta^2}}, \\ h_\phi &= c\sqrt{(\xi^2 - 1)(1 - \eta^2)}. \end{aligned} \quad (3.10)$$

Equation 3.10 is identical to equation 2.2.2a of Ref [17] with $c = \frac{d}{2}$.

As provided in equation 5.1.30 of Ref [3], the expression for the Laplacian in generalized curvilinear coordinates ξ_n is

$$\nabla^2\psi = \sum_n \frac{1}{h_1 h_2 h_3} \frac{\partial}{\partial \xi_n} \left[\frac{h_1 h_2 h_3}{h_n^2} \frac{\partial \psi}{\partial \xi_n} \right]. \quad (3.11)$$

In this application, the prolate spheroidal coordinates allow n to go from 1 to 3. The triplet (ξ_1, ξ_2, ξ_3) corresponds to (ξ, η, ϕ) and the scale factors (h_1, h_2, h_3) transform to (h_ξ, h_η, h_ϕ) . Hence, the prolate spheroidal coordinates representation for ∇^2 is obtained from equation 3.11 utilizing the following process:

(1) Writing out the three terms of equation 3.11

$$\nabla^2 = \frac{1}{h_\xi h_\eta h_\phi} \left[\frac{\partial}{\partial \xi} \left(\frac{h_\eta h_\phi}{h_\xi} \frac{\partial \psi}{\partial \xi} \right) + \frac{\partial}{\partial \eta} \left(\frac{h_\xi h_\phi}{h_\eta} \frac{\partial \psi}{\partial \eta} \right) + \frac{\partial}{\partial \phi} \left(\frac{h_\xi h_\eta}{h_\phi} \frac{\partial \psi}{\partial \phi} \right) \right], \quad (3.12)$$

(2) simplifying the first term of the right-hand side of equation 3.11

$$\begin{aligned} \frac{\partial}{\partial \xi} \left(\frac{h_\eta h_\phi}{h_\xi} \frac{\partial \psi}{\partial \xi} \right) &= \frac{\partial}{\partial \xi} \left(c\sqrt{\frac{\xi^2 - \eta^2}{1 - \eta^2}} \sqrt{(\xi^2 - 1)(1 - \eta^2)} \sqrt{\frac{\xi^2 - 1}{\xi^2 - \eta^2}} \frac{\partial \psi}{\partial \xi} \right) \\ &= \frac{\partial}{\partial \xi} \left(c(\xi^2 - 1) \frac{\partial \psi}{\partial \xi} \right), \end{aligned} \quad (3.13)$$

(3) simplifying the second term of the right-hand side of equation 3.11

$$\begin{aligned}\frac{\partial}{\partial \eta} \left(\frac{h_\xi h_\phi}{h_\eta} \frac{\partial \psi}{\partial \eta} \right) &= \frac{\partial}{\partial \eta} \left(c \sqrt{\frac{\xi^2 - \eta^2}{\xi^2 - 1}} \sqrt{(\xi^2 - 1)(1 - \eta^2)} \sqrt{\frac{1 - \eta^2}{\xi^2 - \eta^2}} \frac{\partial \psi}{\partial \eta} \right) \\ &= \frac{\partial}{\partial \eta} \left(c (1 - \eta^2) \frac{\partial \psi}{\partial \eta} \right),\end{aligned}\tag{3.14}$$

(4) simplifying the third term of the right-hand side of equation 3.11

$$\begin{aligned}\frac{\partial}{\partial \phi} \left(\frac{h_\xi h_\eta}{h_\phi} \frac{\partial \psi}{\partial \phi} \right) &= \frac{\partial}{\partial \phi} \left(c \sqrt{\frac{\xi^2 - \eta^2}{\xi^2 - 1}} \frac{1}{\sqrt{(\xi^2 - 1)(1 - \eta^2)}} \sqrt{\frac{\xi^2 - \eta^2}{1 - \eta^2}} \frac{\partial \psi}{\partial \phi} \right) \\ &= \frac{\partial}{\partial \phi} \left(c \frac{\xi^2 - \eta^2}{(\xi^2 - 1)(1 - \eta^2)} \frac{\partial \psi}{\partial \phi} \right).\end{aligned}\tag{3.15}$$

(5) Note that

$$\begin{aligned}\frac{1}{h_\xi h_\eta h_\phi} &= \frac{1}{c^3} \sqrt{\frac{\xi^2 - 1}{\xi^2 - \eta^2}} \sqrt{\frac{1 - \eta^2}{\xi^2 - \eta^2}} \frac{1}{\sqrt{(\xi^2 - 1)(1 - \eta^2)}} \\ &= \frac{1}{c^3 (\xi^2 - \eta^2)}.\end{aligned}\tag{3.16}$$

(6) Combining steps (1) through (5) above produced the results stated in equation 1.6

$$\nabla^2 \equiv \frac{1}{c^2 (\xi^2 - \eta^2)} \left[\frac{\partial}{\partial \xi} \left((\xi^2 - 1) \frac{\partial}{\partial \xi} \right) + \frac{\partial}{\partial \eta} \left((1 - \eta^2) \frac{\partial}{\partial \eta} \right) + \frac{\xi^2 - \eta^2}{(\xi^2 - 1)(1 - \eta^2)} \frac{\partial^2}{\partial \phi^2} \right].$$

3.3 Separation of Variables in Prolate Spheroidal Coordinates

This section constructs a general solution of the Helmholtz equation

$\nabla^2 \psi + K^2 \psi = 0$ given in Chapter 1. Written in prolate spheroidal coordinates (ξ, η, ϕ) ,

equation 1.2 (the Helmholtz equation) is

$$\begin{aligned}\frac{1}{c^2 (\xi^2 - \eta^2)} \left(\frac{\partial}{\partial \xi} \left((\xi^2 - 1) \frac{\partial \psi}{\partial \xi} \right) + \frac{\partial}{\partial \eta} \left((1 - \eta^2) \frac{\partial \psi}{\partial \eta} \right) + \frac{\xi^2 - \eta^2}{(\xi^2 - 1)(1 - \eta^2)} \frac{\partial^2 \psi}{\partial \phi^2} \right) \\ + K^2 \psi = 0.\end{aligned}\tag{3.17}$$

Divide both sides of equation 3.17 by ψ , yields

$$\begin{aligned} \frac{1}{c^2(\xi^2 - \eta^2)\psi} \left(\frac{\partial}{\partial \xi} \left((\xi^2 - 1) \frac{\partial \psi}{\partial \xi} \right) + \frac{\partial}{\partial \eta} \left((1 - \eta^2) \frac{\partial \psi}{\partial \eta} \right) + \frac{\xi^2 - \eta^2}{(\xi^2 - 1)(1 - \eta^2)} \frac{\partial^2 \psi}{\partial \phi^2} \right) \\ + K^2 = 0. \end{aligned} \quad (3.18)$$

The general method of separation of variables applied to partial differential equations in three dimensions, assumes the wave function ψ to be a product of three functions. In particular,

$$\psi(\xi, \eta, \phi) = w_1(\xi) w_2(\eta) w_3(\phi). \quad (3.19)$$

Using equation 3.19 and changing the partial differential operators to ordinary differential operators, equation 3.18 becomes

$$\begin{aligned} \frac{1}{c^2(\xi^2 - \eta^2)w_1} \frac{d}{d\xi} \left((\xi^2 - 1) \frac{dw_1}{d\xi} \right) + \frac{1}{c^2(\xi^2 - \eta^2)w_2} \frac{d}{d\eta} \left((1 - \eta^2) \frac{dw_2}{d\eta} \right) \\ + \frac{1}{c^2(\xi^2 - 1)(1 - \eta^2)w_3} \frac{d^2 w_3}{d\phi^2} + K^2 = 0. \end{aligned} \quad (3.20)$$

In order to isolate the ϕ -dependence, multiply both sides of equation 3.20 by $c^2(\xi^2 - 1)(1 - \eta^2)$ and rearrange terms to obtain

$$\begin{aligned} \frac{1}{w_3} \frac{d^2 w_3}{d\phi^2} = - \frac{(\xi^2 - 1)(1 - \eta^2)}{(\xi^2 - \eta^2)w_1} \frac{d}{d\xi} \left((\xi^2 - 1) \frac{dw_1}{d\xi} \right) \\ - \frac{(\xi^2 - 1)(1 - \eta^2)}{(\xi^2 - \eta^2)w_2} \frac{d}{d\eta} \left((1 - \eta^2) \frac{dw_2}{d\eta} \right) \\ - \gamma^2 (\xi^2 - 1) (1 - \eta^2) \end{aligned} \quad (3.21)$$

with $\gamma^2 = K^2 c^2$. The left-hand side of equation 3.21 depends on ϕ , while the right-hand side is independent of ϕ . We conclude that both sides of equation 3.21

are equal to the separation constant $-m^2 \in \mathbb{C}$. The ϕ -dependent equation from equation 3.21 is

$$\frac{1}{w_3} \frac{d^2 w_3}{d\phi^2} = -m^2. \quad (3.22)$$

Similar to Ref [17] page 12, this work is interested only in solutions satisfying the physical requirement of single valuedness and finiteness of the wave function at the pole of the prolate spheroid. Therefore m must be a positive integer.

The other coupled equation is

$$\begin{aligned} \frac{(\xi^2 - 1)(1 - \eta^2)}{(\xi^2 - \eta^2) w_1} \frac{d}{d\xi} \left((\xi^2 - 1) \frac{dw_1}{d\xi} \right) + \frac{(\xi^2 - 1)(1 - \eta^2)}{(\xi^2 - \eta^2) w_2} \frac{d}{d\eta} \left((1 - \eta^2) \frac{dw_2}{d\eta} \right) \\ + \gamma^2 (\xi^2 - 1) (1 - \eta^2) = m^2. \end{aligned} \quad (3.23)$$

Multiply both sides of equation 3.23 by $\frac{\xi^2 - \eta^2}{(\xi^2 - 1)(1 - \eta^2)}$ and rearrange terms lead to

$$\begin{aligned} \frac{1}{w_1} \frac{d}{d\xi} \left((\xi^2 - 1) \frac{dw_1}{d\xi} \right) + \frac{1}{w_2} \frac{d}{d\eta} \left((1 - \eta^2) \frac{dw_2}{d\eta} \right) \\ - \frac{m^2 (\xi^2 - \eta^2)}{(\xi^2 - 1)(1 - \eta^2)} + \gamma^2 (\xi^2 - \eta^2) = 0. \end{aligned} \quad (3.24)$$

Observe that the factor multiplying $-m^2$ in equation 3.24 is simplified as

$$\begin{aligned} \frac{\xi^2 - \eta^2}{(\xi^2 - 1)(1 - \eta^2)} &= \frac{\xi^2 - 1 + 1 - \eta^2}{(\xi^2 - 1)(1 - \eta^2)} \\ &= \frac{\xi^2 - 1}{(\xi^2 - 1)(1 - \eta^2)} + \frac{1 - \eta^2}{(\xi^2 - 1)(1 - \eta^2)} \\ &= \frac{1}{1 - \eta^2} + \frac{1}{\xi^2 - 1}. \end{aligned} \quad (3.25)$$

Working with equation 3.25, equation 3.24 is transformed into

$$\begin{aligned} -\frac{1}{w_1} \frac{d}{d\xi} \left((1 - \xi^2) \frac{dw_1}{d\xi} \right) + \frac{1}{w_2} \frac{d}{d\eta} \left((1 - \eta^2) \frac{dw_2}{d\eta} \right) \\ - m^2 \left(\frac{1}{1 - \eta^2} - \frac{1}{1 - \xi^2} \right) + \gamma^2 \xi^2 - \gamma^2 \eta^2 = 0. \end{aligned} \quad (3.26)$$

Equation 3.26 is decoupled into the two similar expressions in η and ξ respectively

$$\begin{aligned} \frac{1}{w_2} \frac{d}{d\eta} \left((1 - \eta^2) \frac{dw_2}{d\eta} \right) - \frac{m^2}{1 - \eta^2} - \gamma^2 \eta^2 \\ = \frac{1}{w_1} \frac{d}{d\xi} \left((1 - \xi^2) \frac{dw_1}{d\xi} \right) - \frac{m^2}{1 - \xi^2} - \gamma^2 \xi^2. \end{aligned} \quad (3.27)$$

Due to the presence of $-\gamma^2 \eta^2$ and $-\gamma^2 \xi^2$, both sides of equation 3.27 represent a modified spherical associated Legendre equation. Continuing with the method of separation of variables, λ is the second separation constant introduced to obtain

$$\frac{1}{w_2} \frac{d}{d\eta} \left((1 - \eta^2) \frac{dw_2}{d\eta} \right) - \frac{m^2}{1 - \eta^2} - \gamma^2 \eta^2 = -\lambda, \quad (3.28)$$

and

$$\frac{1}{w_1} \frac{d}{d\xi} \left((1 - \xi^2) \frac{dw_1}{d\xi} \right) - \frac{m^2}{1 - \xi^2} - \gamma^2 \xi^2 = -\lambda. \quad (3.29)$$

Multiplying both sides of equations 3.28 and 3.29 by w_2 and w_1 , respectively, and rearranging terms leads to Ref [17, 18] the standard forms:

$$\frac{d}{d\eta} \left((1 - \eta^2) \frac{dw_2}{d\eta} \right) + \left(\lambda - \gamma^2 \eta^2 - \frac{m^2}{1 - \eta^2} \right) w_2 = 0, \quad (3.30)$$

and

$$\frac{d}{d\xi} \left((1 - \xi^2) \frac{dw_1}{d\xi} \right) + \left(\lambda - \gamma^2 \xi^2 - \frac{m^2}{1 - \xi^2} \right) w_1 = 0. \quad (3.31)$$

Notice that equations 3.30 and 3.31 have the same functional form. The solutions differ in the range of values for the independent variable: $\eta \in (-1, 1)$ for equations 3.30, and $\xi \in (1, +\infty)$ for equation 3.31.

Analogous to the physical restriction imposed on m , the fact that the solution must be finite means λ must be an integer. To comply with the literature Ref [17], λ

will be replaced with λ_{mn} , with the caveat n is an integer. Therefore equations 3.30 and 3.31 become

$$\frac{d}{d\eta} \left((1 - \eta^2) \frac{dw_2}{d\eta} \right) + \left(\lambda_{mn} - \gamma^2 \eta^2 - \frac{m^2}{1 - \eta^2} \right) w_2 = 0, \quad (3.32)$$

and

$$\frac{d}{d\xi} \left((1 - \xi^2) \frac{dw_1}{d\xi} \right) + \left(\lambda_{mn} - \gamma^2 \xi^2 - \frac{m^2}{1 - \xi^2} \right) w_1 = 0. \quad (3.33)$$

3.3.1 Angular Prolate Spheroidal Equation

Equation 3.32,

$$\frac{d}{d\eta} \left((1 - \eta^2) \frac{dw_2}{d\eta} \right) + \left(\lambda_{mn} - \gamma^2 \eta^2 - \frac{m^2}{1 - \eta^2} \right) w_2 = 0,$$

is recognized as the standard angular prolate spheroidal equation. For each $m \in \mathbb{Z}$, $m \geq 0$, and $n \in \mathbb{Z}$, $n \geq m$, equation 3.32 has eigenvalues $\lambda = \lambda_{mn}$. To facilitate understanding and subsequent development let $w_2 \equiv S_{mn}(\gamma, \eta)$. Consequently equation 3.32 is written as

$$\frac{d}{d\eta} \left((1 - \eta^2) \frac{S_{mn}(\gamma, \eta)}{d\eta} \right) + \left(\lambda - \gamma^2 \eta^2 - \frac{m^2}{1 - \eta^2} \right) S_{mn}(\gamma, \eta) = 0 \quad (3.34)$$

which coincides with equation (3.3.2) of Ref [17].

3.3.2 Power Series Expansion for $S_{mn}(\gamma, \eta)$

An observation of equation 3.34 suggests that, as in Ref [17] page 16, the following power series solution for $S_{mn}(\gamma, \eta)$,

$$S_{mn}(\gamma, \eta) = \sum_{r=0,1}^{\infty} 'd_r^{mn}(\gamma) P_{m+r}^m(\eta). \quad (3.35)$$

The prime over the summation sign indicates that the summation is over only even values of r when $n - m$ is even and odd values of r when $n - m$ is odd. The coefficients $d_r^{mn}(\gamma)$ are given as a recursion relation in Ref [17] page 17,

$$\begin{aligned} & \frac{(2m+r+2)(2m+r+1)c^2}{(2m+2r+3)(2m+2r+5)} d_{r+2}^{mn}(c) \\ & + \left[(m+r)(m+r+1) - \lambda_{mn}(c) + \frac{2(m+r)(m+r+1) - 2m^2 - 1}{(2m+2r-1)(2m+2r+3)} c^2 \right] d_r^{mn}(c) \\ & + \frac{r(r-1)c^2}{(2m+2r-3)(2m+2r-1)} d_{r-2}^{mn}(c) = 0, \quad (r \geq 0). \end{aligned} \quad (3.36)$$

Equation 3.36 is obtained by substituting the following formulas

$$P_{m+r}^m(\eta) = (1 - \eta^2)^{m/2} \frac{d^m P_{m+r}(\eta)}{d\eta^m} \quad (\text{Ferris' definition for } -1 \leq \eta \leq 1), \quad (3.37)$$

$$P_{m+r}(\eta) = \frac{1}{2^{m+r}(m+r)!} \frac{d^{m+r}}{d\eta^{m+r}} (\eta^2 - 1)^{m+r} \quad \text{and} \quad (3.38)$$

$$P_n^m(\eta) = (1 - \eta^2)^{m/2} \frac{d^m}{d\eta^m} \left(\frac{1}{2^n n!} \frac{d^n}{d\eta^n} (\eta^2 - 1)^n \right) \quad (3.39)$$

into the differential equation 3.34. As discussed in Ref[17] page 17, equation 3.36 is a linear homogeneous difference equation of the second order, thereby has two nontrivial independent solutions. This thesis considers only the solution leading to a convergent series. To illustrate the point made above the following procedure is used. Firstly, use equation 3.36 to solve for $d_r^{mn}(\gamma)$ in terms of $d_{r+2}^{mn}(\gamma)$ and $d_{r-2}^{mn}(\gamma)$. Secondly, divide $d_r^{mn}(\gamma)$ by $d_{r-2}^{mn}(\gamma)$. Thirdly, take the limit as $r \rightarrow \infty$. The procedure above produces the ratio

$$\frac{d_r^{mn}(\gamma)}{d_{r-2}^{mn}(\gamma)} \rightarrow \frac{-c^2}{4r^2}$$

which vanishes at the limit. Therefore the spheroidal wave function $S_{mn}(\gamma)$ contained in the angular prolate spheroidal equation is completely determined.

3.3.3 Radial Prolate Spheroidal Equation

Equation 3.33 with $w_1 \equiv R_{mn}(\gamma, \xi)$, the radial prolate spheroidal equation is

$$\frac{d}{d\xi} \left((1 - \xi^2) \frac{dR_{mn}(\gamma, \xi)}{d\xi} \right) + \left(\lambda_{mn} - \gamma^2 \xi^2 - \frac{m^2}{1 - \xi^2} \right) R_{mn}(\gamma, \xi) = 0. \quad (3.40)$$

Simplification leads to

$$(\xi^2 - 1) \frac{d^2 R_{mn}(\gamma, \xi)}{d\xi^2} + 2\xi \frac{dR_{mn}(\gamma, \xi)}{d\xi} + \left(\gamma^2 \xi^2 - \lambda_{mn} - \frac{m^2}{\xi^2 - 1} \right) R_{mn}(\gamma, \xi) = 0, \quad (3.41)$$

which is a modified radial Bessel differential equation in prolate spheroidal coordinates. Recall equation 2.30

$$\rho^2 \frac{d^2 R}{d\rho^2} + 2\rho \frac{dR}{d\rho} + (\rho^2 - l(l+1)) R = 0$$

has two solutions j and n . j is known to be regular at the origin while n has a logarithmic singularity there. In addition the spherical Hankel function of the first kind, $h^{(1)} = j + in$, is also a solution of equation 2.30.

Analogous to equation 2.30, equation 3.41 posses two solutions $R^{(1)}$ which is regular at the origin and $R^{(2)}$ exhibiting logarithmic singularity also at the origin. The complex sum of the two solutions $R^{(3)} = R^{(1)} + iR^{(2)}$ is also a solution of equation 3.41. Therefore $R^{(1)}$, $R^{(2)}$ and $R^{(3)}$ are the prolate spheroidal analogues of j , n and $h^{(1)}$. For this scattering problem only $R^{(1)}$ and $R^{(3)}$ are needed since $R^{(1)}$ will be contained in the solution for the interior of the soft prolate spheroidal object and $R^{(3)}$ will be part of the scattered wave at large distances Ref [17], Ref [18], Ref [19], Ref [20], Ref [21], Ref [22], Ref [23]. With the complete knowledge of S_{mn} , $R_{mn}^{(1)}$ and $R_{mn}^{(3)}$, equations 3.30 and 3.31 are completely solved.

The power series representation for $R_{mn}^{(1)}$, $R_{mn}^{(2)}$ and $R_{mn}^{(3)}$ are explicitly provided in Ref [17], equations (4.1.15), (4.1.16) and (4.1.19). In particular, they are given as follows

$$\begin{aligned}
R_{mn}^{(1)}(\gamma, \xi) &= \frac{1}{\sum_{r=0,1}^{\infty} 'd_r^{mn}(\gamma) \frac{(2m+r)!}{r!}} \left(\frac{\xi^2 - 1}{\xi^2} \right)^{\frac{1}{2}m} \sum_{r=0,1}^{\infty} 'i^{r+m-n} d_r^{mn}(\gamma) \frac{(2m+r)!}{r!} j_{m+r}(\gamma\xi) \\
R_{mn}^{(2)}(\gamma, \xi) &= \frac{1}{\sum_{r=0,1}^{\infty} 'd_r^{mn}(\gamma) \frac{(2m+r)!}{r!}} \left(\frac{\xi^2 - 1}{\xi^2} \right)^{\frac{1}{2}m} \sum_{r=0,1}^{\infty} 'i^{r+m-n} d_r^{mn}(\gamma) \frac{(2m+r)!}{r!} n_{m+r}(\gamma\xi) \\
R_{mn}^{(3)}(\gamma, \xi) &= \frac{1}{\sum_{r=0,1}^{\infty} 'd_r^{mn}(\gamma) \frac{(2m+r)!}{r!}} \left(\frac{\xi^2 - 1}{\xi^2} \right)^{\frac{1}{2}m} \sum_{r=0,1}^{\infty} 'i^{r+m-n} d_r^{mn}(\gamma) \frac{(2m+r)!}{r!} h_{m+r}^{(1)}(\gamma\xi).
\end{aligned} \tag{3.42}$$

In addition the eigenvalues λ_{mn} contained in equation 3.36 will be determined through the application of the transition conditions of equation 1.12.

3.3.4 The ϕ -dependent Prolate Spheroidal Equation

In equation 3.22 let $w_3 \equiv \Phi(\phi)$, so the equation becomes

$$\frac{d^2\Phi}{d\phi^2} + m^2\Phi = 0 \tag{3.43}$$

which is the harmonic oscillator. Henceforth

$$\Phi_m = \sum_0^{\infty} e^{im\phi}. \tag{3.44}$$

With the knowledge of Φ_m added to that of S_{mn} , $R_{mn}^{(1)}$ and $R_{mn}^{(3)}$ the method of separation of variables displays a regular, well-behaved and bounded solution for the Helmholtz equation, $(\nabla^2 + K^2)\Psi = 0$, in prolate spheroidal coordinates.

3.4 Returning to the Scattering Problem

Provided by Figure 3.5, is a visualization of the problem. The incident wave

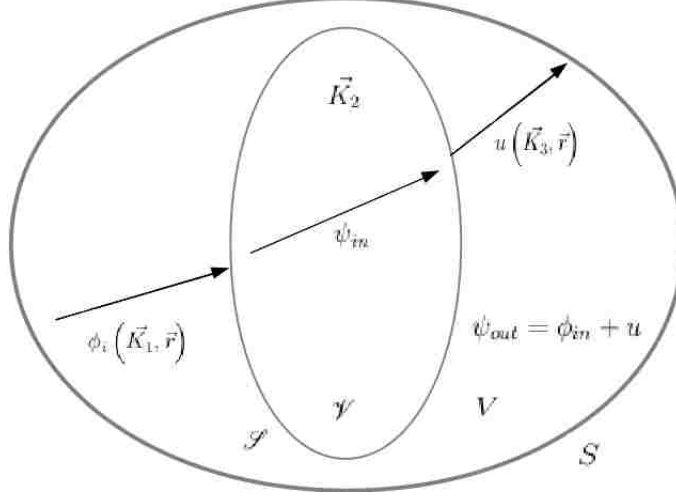

Figure 3.5: Vizualization of the Three Media (Spheroidal)

$\phi_i = e^{i\mathbf{K}_1 \cdot \mathbf{r}}$ satisfying $(\nabla^2 + K_1^2) \phi_i = 0$, has the power series expansion

$$e^{iK_1 r \cos \theta} = 2 \sum_{m,n} i^n \frac{(2 - \delta_{0m})}{N_{mn}} S_{mn}(\gamma_1, \cos v_0) S_{mn}(\gamma_1, \eta) R_{mn}^{(1)}(\gamma_1, \xi) \cos m(\phi - \phi_0), \quad (3.45)$$

where $\gamma_i = K_i c, i = 1, 2, 3$ and

$$\cos \theta = \cos v \cos v_0 + \sin v \sin v_0 \cos(\phi - \phi_0) \quad (3.46)$$

as in Ref [3] equation 11.3.96, Ref [17] equation 5.3.3, Ref [19] equation 4, Ref [24] equation 1, and Ref [25] equation 2. Here η, ξ, ϕ are the prolate spheroidal coordinates of the point of observation and the v_0, ϕ_0 are the spherical coordinates of the positive propagation of the plane wave.

$$N_{mn} = 2 \sum_{r=0,1}^{\infty} \frac{(r+2m)! (d_r^{mn})^2}{(2r+2m+1)r!} \quad (3.47)$$

is the constant of normalization and δ_{0m} is the Kroneker delta function. In this thesis the work will be done by letting $\theta \rightarrow 0$ and $\phi_0 \rightarrow 0$. Also, in Ref [19] the plane of incidence is $\phi_0 = 0$. Therefore equation 3.45 is written as

$$e^{iK_1 r} = 2 \sum_{m,n} i^n \frac{(2 - \delta_{0m})}{N_{mn}} S_{mn}(\gamma_1, \cos v_0) S_{mn}(\gamma_1, \eta) R_{mn}^{(1)}(\gamma_1, \xi) \cos m\phi. \quad (3.48)$$

Similar to the incident wave the interior solution ψ_{in} satisfying $(\nabla^2 + K_2^2) \psi_{in} = 0$ is given by

$$\psi_{in}(\xi, \eta, \phi) = 2 \sum_{m,n} C_{mn} i^n \frac{(2 - \delta_{0m})}{N_{mn}} S_{mn}(\gamma_2, \cos v_0) S_{mn}(\gamma_2, \eta) \left[{}_{in}R_{mn}^{(1)}(\gamma_2, \xi) \right] \cos m\phi, \quad (3.49)$$

where $\left[{}_{in}R_{mn}^{(1)}(\gamma_2, \xi) \right]$ is the interior solution of the radial prolate spheroidal differential equation Ref [25] equation 4.

The scattered wave u satisfying $(\nabla^2 + K_3^2) u = 0$ is given by

$$u(\xi, \eta, \phi) = 2 \sum_{m,n} D_{mn} i^n \frac{(2 - \delta_{0m})}{N_{mn}} S_{mn}(\gamma_3, \eta) R_{mn}^{(3)}(\gamma_3, \xi) \cos m\phi \quad (3.50)$$

as in Ref [25] equation 3, where the constants C_{mn} and D_{mn} by the using the transition conditions at the surface of the prolate spheroid when $\xi = a$.

3.5 Transition Conditions and the Expansion Coefficients

Combining equation 1.12 with equations 3.48, 3.49, 3.50 gives the following system of algebraic equations to solve for the coefficients C_{mn} and D_{mn} . Proceeding similarly to Ref[1] equation 13 the resulting system of equations is given by

$$\begin{aligned}
A \sum_{m,n} S_{mn}(\gamma_1, \cos \nu_0) S_{mn}(\gamma_1, \eta) R_{mn}^{(1)}(\gamma_1, a) + \sum_{m,n} D_{mn} S_{mn}(\gamma_3, \eta) R_{mn}^{(3)}(\gamma_3, a) & \quad (3.51) \\
= A' \sum_{m,n} C_{mn} S_{mn}(\gamma_2, \eta) [\text{in} R_{mn}^{(1)}(\gamma_2, a)] &
\end{aligned}$$

and

$$\begin{aligned}
B \sum_{m,n} S_{mn}(\gamma_1, \cos \nu_0) S_{mn}(\gamma_1, \eta) R_{mn}^{(1)'}(\gamma_1, a) + \sum_{m,n} D_{mn} S_{mn}(\gamma_3, \eta) R_{mn}^{(3)'}(\gamma_3, a) & \quad (3.52) \\
= B' \sum_{m,n} C_{mn} S_{mn}(\gamma_2, \eta) [\text{in} R_{mn}^{(1)'}(\gamma_2, a)]. &
\end{aligned}$$

Equations 3.51 and 3.52 are very complicated equations to solve. Nonetheless, an algebraic solution does exist using the orthogonality of the spheroidal wave [see Ref [18], Ref [24] equation 7 and Ref [25] equations 6 and 10]. With the values of C_{mn} and D_{mn} the series solution for the penetrable prolate spheroid is completely determined.

Similar to Twersky Ref [1] equation 21 and Ref [24] equation 20, a power series for the scattering amplitude, which is the response of the prolate spheroid to the propagation of the acoustic wave, can be deduced from equation 3.50. Notice that the scattering amplitude is only a function of angles. In particular,

$$g(\eta, \phi) = 2 \sum_{mn} i^{mn} D_{mn} \frac{2 - \delta_{mn}}{N_{mn}} S_{mn}(\gamma_3, \eta) \cos m\phi. \quad (3.53)$$

This is identical to the result published in Ref [26] equation 10.

3.6 Green's Function Representation

The Green's function representation follows exactly the derivation in Section 2.6, where the functions used now are described in prolate spheroidal coordinates. In particular,

$$(\nabla^2 + k^2)\mathcal{G}(\vec{r}, \vec{r}') = -\delta(\vec{r} - \vec{r}') \quad (3.54)$$

where

$$\delta(\vec{r} - \vec{r}') = h_\eta^{-1} h_\xi^{-1} h_\phi^{-1} \delta(\eta - \eta') \delta(\xi - \xi') \delta(\phi - \phi'). \quad (3.55)$$

In prolate spheroidal coordinates the Green's function expansion as in Ref [17] equation 5.2.9 is

$$\frac{e^{ik|\vec{r}-\vec{r}'|}}{4\pi|\vec{r}-\vec{r}'|} = \frac{ik}{2\pi} \sum_{m=0}^{\infty} \sum_{n=m}^{\infty} \frac{2 - \delta_{mn}}{N_{mn}} S_{mn}(\gamma, \eta) S_{mn}(\gamma, \eta') \cos m(\phi - \phi') \quad (3.56)$$

$$\begin{cases} R_{mn}^{(1)}(\gamma, \xi) R_{mn}^{(3)}(\gamma, \xi'), & \xi < \xi' \\ R_{mn}^{(1)}(\gamma, \xi') R_{mn}^{(3)}(\gamma, \xi), & \xi > \xi'. \end{cases}$$

A major difference between Twersky's work and this thesis is in addition to working in spheroidal coordinates, the Green's function is broken into two pieces depending on $\xi < \xi'$ or $\xi' < \xi$. Therefore, the functional forms of equations 2.60, 2.61 and 2.62 do remain consistent with the understanding that $\mathcal{G} \rightarrow \mathcal{G}$, $u \rightarrow \mathcal{U}$, $\phi \rightarrow \Phi$ and $\psi \rightarrow \Psi$. Hence, they are transformed into

$$\mathcal{U}(k\vec{r}) = \left\{ \mathcal{G}\left(k\left|\vec{r}-\vec{r}'\right|\right), \mathcal{U}(k\vec{r}) \right\}, \quad (3.57)$$

$$\mathcal{U}(k\hat{o}, \hat{i}) = \left\{ h_0\left(k\left|\vec{r}-\vec{r}'\right|\right), \mathcal{U}\left(\vec{r}', \hat{i}\right) \right\} \text{ and}$$

$$\mathcal{U}(k\hat{o}, \hat{i}) = \left\{ h_0\left(k\left|\vec{r}-\vec{r}'\right|\right), \Psi_{out}\left(\vec{r}', \hat{i}\right) \right\}.$$

Where once again, \hat{o} and \hat{i} are the unit vectors of observation and propagation respectively. In addition, the brace algebra, the surface integral, is operating at the surface of the scatterer. Equation 3.57 allows us to calculate the scattered wave from the outside when the solution is known at the surface.

3.7 Operator Form of the Spheroidal Scattering Amplitude

This treatment will take place in the domain where $\xi \gg \xi'$. In the concerned region only the second part of the Green's function will be considered, in particular

$$\begin{aligned} \mathcal{G} &= \frac{e^{ik|r-r'|}}{4\pi|r-r'|} \\ &= \frac{ik}{2\pi} \sum_{m=0}^{\infty} \sum_{m=m}^{\infty} \frac{2-\delta_{mn}}{N_{mn}} S_{mn}(\gamma, \eta) S_{mn}(\gamma, \eta') \cos m(\Phi - \Phi') R_{mn}^{(1)}(\gamma, \xi') R_{mn}^{(3)}(\gamma, \xi). \end{aligned} \quad (3.58)$$

Due to the symmetry of the Green's Functions $S(\gamma, \eta) = S(\gamma, -\eta)$ and $S(\gamma, \eta') = S(\gamma, -\eta')$. Asymptotically, when $\xi \gg \xi''$ the radial functions $R_{mn}^{(1)}(\gamma, \xi)$ and $R_{mn}^{(3)}(\gamma, \xi)$ take the forms

$$R_{mn}^{(1)}(\gamma, \xi') \rightarrow \frac{1}{\gamma\xi'} \sin\left(\gamma\xi' - \frac{m+n}{2}\pi\right) = j_{m+n}(\gamma, \xi') \quad (3.59)$$

and

$$R_{mn}^{(3)}(\gamma, \xi) \rightarrow \frac{1}{\gamma\xi} \sin\left(\gamma\xi - \frac{m+n+1}{2}\pi\right). \quad (3.60)$$

See Ref [27] for more details.

The asymptotic form of the Green's function analogous to Ref [1], in spheroidal coordinates, is

$$\begin{aligned} \mathcal{G}(k|\xi - \xi'|) &\sim \quad (3.61) \\ \frac{ik}{2\pi} \sum_{m=0}^{\infty} \sum_{n=m}^{\infty} \frac{2 - \delta_{mn}}{N_{mn}} S_{mn}(\gamma, -\eta) S_{mn}(\gamma, -\eta') \cos m(\phi - \phi') j_{m+n}(\gamma, \xi') \frac{1}{\gamma\xi} e^{i(\gamma\xi - \frac{m+n+1}{2}\pi)}. \end{aligned}$$

Similar to Ref [9] equation (18), $e^{-ikr'}$ is written as

$$e^{-ikr'} = \sum_{m=0}^{\infty} \sum_{n=0}^{\infty} \frac{2 - \delta_{mn}}{N_{mn}} S_{mn}(\gamma, -\eta) S_{mn}(\gamma, -\eta') \cos m(\phi - \phi') j_{m+n}(\gamma, \xi'). \quad (3.62)$$

Substituting 3.62 and 3.61 yields

$$\mathcal{G}(k|\xi - \xi'|) \sim \frac{ike^{-ikr'}}{4\pi\gamma\xi} e^{i(\gamma\xi - \frac{m+n+1}{2}\pi)}. \quad (3.63)$$

Substituting equation 3.63 into the middle part of equation 3.57 and integrating ξ' yields

$$\begin{aligned} \mathcal{U}(k\hat{o}, \hat{i}) &\sim \left\{ \frac{ike^{-ikr'}}{4\pi} \frac{1}{\gamma\xi} e^{i(\gamma\xi - \frac{m+n+1}{2}\pi)}, \mathcal{U}(\xi', \hat{i}) \right\} \quad (3.64) \\ &= \frac{ik}{4\pi} \frac{1}{\gamma\xi} e^{i(\gamma\xi - \frac{m+n+1}{2}\pi)} \left\{ e^{-ikr'}, \mathcal{U}(\xi', \hat{i}) \right\} \\ &= h(\gamma\xi) \mathfrak{g}(k\hat{o}, K_1\hat{i}) \end{aligned}$$

where

$$\mathbf{g} = \frac{ike^{-i\frac{m+n}{2}\pi}}{4\pi} \left\{ e^{-ikr'}, \mathcal{U}(\xi', \hat{i}) \right\}. \quad (3.65)$$

Therefore equation 3.65 is the spheroidal analogue of Twersky's Ref [1] equation 31.

3.8 Reciprocity Relation and Energy Theorem

3.8.1 Reciprocity Relation

Similar to section 2.7 equation 2.68, the prolate spheroidal coordinate analogue is

$$\{\Psi_1, \Psi_2\} = 0 \quad (3.66)$$

The subscripts indicate two different solutions of the same differential equation satisfying the same boundary condition at the surface of the scatterer, where $\Psi_i = \Phi_i + \mathcal{U}_i$.

The derivation follows closely the work done by Twersky in Ref [7] and section 2.7 of this thesis. The prolate spheroidal analogue of equation 2.74 is

$$\{\Phi_1, \mathcal{U}_2\} = \{\Phi_2, \mathcal{U}_1\} \quad (3.67)$$

and it's surface integral is given by

$$\begin{aligned} & \oint (e^{i\vec{K}_1 \cdot \vec{r}'} \partial_n \mathcal{U}_2(\vec{K}_2 \vec{r}') - \mathcal{U}_2(\vec{K}_2 \vec{r}') \partial_n e^{i\vec{K}_1 \cdot \vec{r}'}) d\mathcal{S}(\vec{r}') \\ &= \oint (e^{i\vec{K}_2 \cdot \vec{r}'} \partial_n \mathcal{U}_1(\vec{K}_1 \vec{r}') - \mathcal{U}_1(\vec{K}_1 \vec{r}') \partial_n e^{i\vec{K}_2 \cdot \vec{r}'}) d\mathcal{S}(\vec{r}'). \end{aligned} \quad (3.68)$$

Using equation 3.65 in equation 3.68 gives

$$\mathbf{g}(-\hat{K}_1, \hat{K}_2) = \mathbf{g}(-\hat{K}_2, \hat{K}_1) \quad (3.69)$$

which is the general reciprocity relation in prolate spheroidal coordinates.

3.8.2 Energy Theorem

Rewriting equation 2.78 in prolate spheroidal coordinates gives

$$\{\Phi_1^*, \mathcal{U}_2\} + \{\mathcal{U}_1^*, \Phi_2\} = -\{\mathcal{U}_1^*, \mathcal{U}_2\}. \quad (3.70)$$

Proceeding similarly to subsection 2.7.2, the first term on the left hand side of 3.70 is the scattering amplitude defined in equation 3.65,

$$\{\Phi_1^*, \mathcal{U}_2\} = \{e^{-i\hat{K}_1 \cdot \hat{K}_2 \cdot \vec{r}^j}, \mathcal{U}_2\} = \mathfrak{g}(\hat{K}_1, \hat{K}_2). \quad (3.71)$$

The second term on the left hand side of equation 3.70,

$$\{\mathcal{U}_1^*, \Phi_2\} = -\{\Phi_2, \mathcal{U}_1^*\}. \quad (3.72)$$

Here the prolate spheroidal analogue to the definition in equation 2.66,

$$\mathfrak{g}(\hat{K}_2, \hat{K}_1) = \{e^{-iK_1 \hat{K}_2 \cdot \vec{r}^j}, \mathcal{U}_1(\hat{K}_1 \vec{r}^j)\}, \quad (3.73)$$

is used. Taking the complex conjugate of equation 3.73

$$\begin{aligned} \mathfrak{g}^*(\hat{K}_2, \hat{K}_1) &= \{e^{-iK_1 \hat{K}_2 \cdot \vec{r}^j}, \mathcal{U}_1(\hat{K}_1 \vec{r}^j)\}^* \\ &= \{\Phi_2, \mathcal{U}_1^*\}^* \\ &= -\{\Phi_2, \mathcal{U}_1^*\}. \end{aligned} \quad (3.74)$$

The right hand side of equation 3.70

$$\{\mathcal{U}_1^*, \mathcal{U}_2\} = 2\mathcal{M}[\mathfrak{g}^*(\hat{o}, \hat{K}_1)\mathfrak{g}(\hat{o}, \hat{K}_2)] \quad (3.75)$$

where \mathcal{M} is the mean over all values of $\hat{\delta}$ when dealing with the solid angle in prolate spheroidal coordinates analogous to Ref [7] equation 22 and Ref [28] equation 30.

Therefore, equation 3.70 becomes

$$-(\mathbf{g}(\hat{K}_1, \hat{K}_2) + \mathbf{g}^*(\hat{K}_2, \hat{K}_1)) = 2\mathcal{M}[\mathbf{g}^*(\hat{\delta}, \hat{K}_1)\mathbf{g}(\hat{\delta}, \hat{K}_2)] \quad (3.76)$$

which, similar to equation 2.84, is the general form of the Energy Theorem. Again in the case where $\hat{K}_1 = \hat{K}_2 = \hat{K}$, equation 3.76

$$-(\mathbf{g}(\hat{K}, \hat{K}) + \mathbf{g}^*(\hat{K}, \hat{K})) = 2\mathcal{M}[\mathbf{g}^*(\hat{\delta}, \hat{K}_1)\mathbf{g}(\hat{\delta}, \hat{K}_2)]. \quad (3.77)$$

Simplifying equation 3.77 gives, analogous to Ref [4] and Ref [7],

$$-Re(\mathbf{g}(\hat{K}, \hat{K})) = \mathcal{M}\mathbf{g}(\hat{\delta}, \hat{K}) = \frac{1}{2}\{\mathcal{U}^*, \mathcal{U}\} = \frac{\varsigma_S}{\varsigma_o}. \quad (3.78)$$

where ς_s is the scattering cross section.

3.8.3 Energy Theorem for a Lossy and a Gainy Scatterer

For a lossy scatterer, equation 2.77 does not vanish. Instead,

$$\{\psi_1^*, \psi_2\} = \frac{\sigma_A}{\sigma_o} \quad (3.79)$$

where σ_A is the absorption cross section as in Ref [28] equation 24 when working in spherical coordinates. The prolate spheroidal analogue of equation 3.79 is

$$\{\Psi_1^*, \Psi_2\} = \frac{\varsigma_A}{\varsigma_o}. \quad (3.80)$$

Following the previous development of subsection 3.8.2 and using equation 3.78, equation 3.80 is transformed into

$$-Re(\mathbf{g}(\hat{K}, \hat{K})) = -\frac{1}{2}\{\Psi^*, \Psi\} + \frac{1}{2}\{\mathcal{U}^*, \mathcal{U}\} = \frac{\varsigma_A + \varsigma_S}{\varsigma_o}. \quad (3.81)$$

For a gainy scatterer, the incident wave might produce energy of the form $-\varsigma_A$.

Therefore, equation 3.81 becomes

$$-\varsigma_o Re(\mathfrak{g}(\hat{K}, \hat{K})) = -\varsigma_A + \varsigma_S. \quad (3.82)$$

For more details see Ref[28] equation 35 and 36.

CHAPTER 4

APPLICATIONS

The application of scattering in problems involving the STEM discipline, industrial activities and medicine are numerous and diverse. Wherever scattering amplitude is needed the work done in this thesis is applicable. Of course, the geometry involved has to be one that can be approximated by a prolate spheroid. It is beyond the scope of this work to discuss all of the possible applications. However, an effort is made to cover some interesting cases. This chapter begins by discussing C. Yehs work in Ref [29].

4.1 C. Yeh

In C. Yehs Scattering of Acoustic Waves by a Penetrable Prolate Spheroid. I. Liquid Prolate Spheroid Ref [29], the problem of scattering of an acoustic wave by a fluid filled prolate spheroid is considered. Power series expansions were utilized to derive the asymptotic approximation of the scattered wave given in equations 4 and 5 of the above mentioned reference. Also, the relevance of the solution to the scattering by submarines and whales was identified.

Equations 4 and 5, the major equations of the reference, could have been easily deduced using Twerkys version of the work done in this thesis. The appropriate equations are 3.64 and 3.65, they entail the scattered wave and the scattering amplitude. Since most measurements use the optical theorem which is the specialized

energy theorem of equation 3.78 for both forward and backscattering, the result of the thesis is directly applicable.

Yeh treated the case of the oblique incidence and allowed θ_0 to vary from 0° to 30° , to 60° and to 90° . The case that corresponds to the work done in this thesis is when $\theta_0 = 0$ degrees, represented by the figure in Ref [29] page 520 caption (d).

4.2 T. Okumura, T. Masuya, Y. Takao and K. Sawada

The authors of Acoustic Scattering by an Arbitrarily Shaped Body: An Application of the Boundary Element Method Ref [30] used the boundary element method (BEM) to calculate the extinction coefficients and extinction cross-sections of four types of scatterers: vacant, rigid, liquid and gas-filled spheroids . Of the types considered, relevant to this thesis are the fluid and gas filled prolate spheroidal cavities.

The BEM, in comparison to the analytical Twersky approach used in this thesis, is a numerical computational approach. It is based on discretizing the boundary into a finite number of boundary elements. Through solving a single system of equations boundary displacements and tractions are calculated as described in Ref [31].

In Ref [30] the BEM is used to estimate the scattering amplitudes corresponding to different objects. Equation 3,

$$\sigma = \frac{4\pi}{k} \text{Im}[f(k_{in}, k_{in})] \quad (4.1)$$

of Ref [30] is the optical theorem in the forward direction of scattering where $f(k_{in}, k_{in})$ according to Twerskys Ref [32] page 702 is

$$f(k, k) = \frac{1}{ik}g(k, k) \tag{4.2}$$

Recall, $g(k, k)$ is the scattering amplitude in the energy theorem.

This type of scattering problem has application in biological sciences. In particular, when the determination of species, body shapes and target strengths are needed. Consequently, the biological problem is an inverse scattering problem which requires the knowledge of the scattering amplitude. Therefore, equations 3.64 and 3.65 which give the scattered wave and scattering amplitude are germane to the fish identification problem.

The BEM used in the Ref [30] to calculate the scattering amplitude is approximative. Its limitations are well known as documented in Ref [33] and Ref [34]. The resulting matrices are dense, non-symmetric and fully populated making them difficult to solve. The density of these matrices also limits the size of the models to be analyzed. Additionally, the BEM is not well known to the engineering community thus it is not widely used. In addition to the above mentioned difficulties, in all BEM studies one must parametrize the boundary of an obstacle. In two dimensions such difficulties can be overcome with a minimal error. In three dimensions, namely prolate spheroidal coordinates, the difficulties are huge and almost intractable Ref [35].

In contrast, the work done in this thesis generates an integral at the surface or the volume of the scatterer. Outside the scatterer, that is when $r \rightarrow \infty$, the Sommerfeld radiative condition is imposed to guarantee the vanishing of the surface at

S_∞ contribution. Therefore the equations 3.64 and 3.65 are not approximations and they lead to the obtention of the scattered wave outside from the knowledge of the solution on the inside which is measurable.

The ultimate goal of Ref [30] was to obtain a fair approximation for the extinction cross section that determines the attenuation of acoustic waves within a fish school or a cloud of plankton. Equations 3.64 and 3.65 coupled to equation 3.78 of this thesis solve the problem for lossless, lossy and gainy prolate spheroidal obstacles.

4.3 N. Gorska and D. Chu

The authors of Ref [36], in equation 1, use the optical theorem to evaluate the extinction cross section and calculate the scattering amplitude employing the PC-DWBA (Phase-Compensated-Distorted Wave Born Approximation) approach. The scatterer is transparent (penetrable) thus there is a wave inside that satisfies the Helmholtz equation with its own K' depending on the physical characteristics of the medium inside the scatterer. The solution inside the scatterer must be regular therefore it is customary to replace the internal solution by the incident wave. This is what is known as the Born Approximation. In the DWBA (Distorted Wave Born Approximation) the incident wave number inside the integral is replaced by the wave number vector resulting from the local sound speed and frequency of the incident sound wave. For more details see Ref [37].

According to Ref [36] the difficulty with the DWBA approach resides in the phase mismatch between the exact solution and the DWBA based solution. The correction of the phase in-congruence is handled by the PC-DWBA as described in Ref

[38]. According to Chu and Ye of Ref [38] the defect of the DWBA is more profound. The approach ignores the imaginary part of the scattering amplitude violating the optical theorem. Therefore, no extinction cross section can be calculated.

In one dimensional problems the phase compensation method can be easily handled, however in three dimensional models such as a sphere it is quite complicated. It is even more involved when dealing with a prolate spheroid. According to Chu and Ye of Ref [38] the heuristic approach for a penetrable spherical scatterer involves the following steps:

- I. Transform the 3-D problem into a quasi 1-D problem.
- II. Look for a reasonable approximate phase compensation term similar to the 1-D problem.
- III. To obtain a result that is applicable, approximate the sphere by a cylinder by preserving the volume. Therefore, the cylinder can then be transformed into a line.
- IV. Using the center of the sphere as the origin of coordinates, the quasi 1-D approximation of the sphere is achieved.

To the best knowledge of the author of this thesis, the heuristic technique described above has been attempted only for spherical geometry it's extension to prolate spheroidal geometry is yet to be utilized to produce realistic results. Chu and Ye in Ref [38] use the spherical approach to model the prolate spheroid. It is a restrictive case since only when the eccentricity is unity does the prolate spheroid approximation produce the spherical result. This is due to the fact that the prolate spheroid's approximation ignores the imaginary part. Therefore, the PC-DWBA did

not remedy the DWBA for the prolate spheroid. To arrive at a fair approximation Chu and Ye used the equivalent spherical object approximation approach to construct the imaginary part of the scattering amplitude. Henceforth, the optical theorem can be applied.

In contrast the work done in this thesis, equation 3.78 coupled with equation 3.65 directly produces the scattering amplitude g . Recall, what this thesis calls scattering amplitude g is referred to in the literature as f and the relation between f and g is

$$f(k, k) = \frac{1}{ik}g(k, k) \tag{4.3}$$

Therefore, the work in this thesis has great application in Marine Biology as far as when dealing with fish, squid and zooplankton.

CHAPTER 5

CONCLUSION AND FUTURE WORK

5.1 Conclusion

This thesis solves the scattering problem of an acoustic wave impinging on a soft prolate spheroidal scatterer. The main result was obtained by using Twersky's method. The scattered wave solution for the prolate spheroid is given by

$$\begin{aligned}
 \mathcal{U}(k\hat{o}, \hat{i}) &\sim \left\{ \frac{ike^{-ikr'}}{4\pi} \frac{1}{\gamma\xi} e^{i(\gamma\xi - \frac{m+n+1}{2}\pi)}, \mathcal{U}(\xi', \hat{i}) \right\} \\
 &= \frac{ik}{4\pi} \frac{1}{\gamma\xi} e^{i(\gamma\xi - \frac{m+n+1}{2}\pi)} \left\{ e^{-ikr'}, \mathcal{U}(\xi', \hat{i}) \right\} \\
 &= h(\gamma\xi) \mathbf{g}(k\hat{o}, K_1\hat{i})
 \end{aligned} \tag{5.1}$$

where

$$\mathbf{g} = \frac{ike^{-i\frac{m+n}{2}\pi}}{4\pi} \left\{ e^{-ikr'}, \mathcal{U}(\xi', \hat{i}) \right\}. \tag{5.2}$$

In addition, Twersky's reciprocity relation of Ref[1], [5], [7] and [9] and his Brace Algebra permitted the derivation of the Energy Theorem of equation 3.76

$$-(\mathbf{g}(\hat{K}_1, \hat{K}_2) + \mathbf{g}^*(\hat{K}_2, \hat{K}_1)) = 2\mathcal{M}[\mathbf{g}^*(\hat{o}, \hat{K}_1)\mathbf{g}(\hat{o}, \hat{K}_2)] \tag{5.3}$$

for the prolate spheroidal scatterer. Collapsing the prolate spheroid results in the recovery of the solution for the sphere. Therefore the "correspondence principle" cited in Ref[8] is verified.

The effectiveness of the method is captured in the direct calculation of the scattering amplitude. Once the scattering amplitude is known, the scattered wave solution can be obtained. Essentially, they can be viewed as Fourier inverses of each other. In contrast to other works in the literature, where it is extremely difficult to arrive at a direct answer for the scattering amplitude, equation 5.2 provides the scattering amplitude directly. Consequently, most applications do require the knowledge of the scattering amplitude which is the response of the scatterer to the incident wave. Therefore, the work done in this thesis provides professionals in the scattering field a direct avenue to obtaining more accurate measurements.

5.2 Future work

5.2.1 Extension to Oblate Spheroidal Geometry

For scientists engaged in problems involving oblate spheroidal geometries, the work in this thesis can be smoothly extended. A brief sketch of the coordinate system and the Helmholtz Differential Equation are provided in Appendix A.

5.2.2 Numerical Calculations

For research and applications desiring numerical values, a search of the literature for numerical data corresponding to scattering amplitude can be transported and implemented in the Twersky method. In particular, tenuous scatterers which are present in clouds, can be considered. The frequently addressed question in this area

of inquiry involves the knowledge of the cloud morphology (Pruppacher and Klett in Ref[39]), the cloud micro-physics (Rakov and Uman in Ref[40]) and the study of lightning radiative transfer (Koshak and et all in Ref[41]).

5.2.3 Multiple Scattering

The problem solved in this thesis is the single scatterer in isolation. The knowledge of the single scatterer in isolation is the fundamental requirement for the study of multiple scattering as in Ref[5], [6], [7], and [9]. The multiple scattering problem is usually divided into three components:

- (a) The two body problem,
- (b) The fixed configuration of n scatterers which takes into account the way the scatterers are distributed:
 - i. Uniform distributions of identical scatterers,
 - ii. Uniform distributions of heterogeneous scatterers ,
 - iii. Non-uniform distributions of identical scatterers,
 - iv. Non-uniform distributions of heterogeneous scatterers,
- (c) Ensemble of fixed configuration of scatterers.

In all multiple scattering problems, configurational or ensemble averages for the scattering amplitude and the scattered wave must be developed, derived and calculated.

APPENDIX A

Notation and Conventions for Coordinate Systems

In this appendix, we give the transformation equations for the oblate spheroidal coordinate system. These transformation equations relate the Cartesian coordinates (x, y, z) and the curvilinear coordinates (q_1, q_2, q_3) . For convenience, the Helmholtz equation written in oblate spheroidal coordinates is presented.

A.1 Oblate Spheroidal Coordinates

Our notation and conventions for oblate spheroidal coordinates are the same as those used by Morse and Feshbach in Ref[3]. Let $c > 0$ be given. The Cartesian coordinates (x, y, z) and oblate spheroidal coordinates (ξ, η, ϕ) are related by the transformation equations

$$x = c\sqrt{(\xi^2 + 1)(1 - \eta^2)} \cos \phi, \tag{A.1}$$

$$y = c\sqrt{(\xi^2 + 1)(1 - \eta^2)} \sin \phi, \tag{A.2}$$

$$z = c\xi\eta, \tag{A.3}$$

with $1 \leq \xi < +\infty$, $-1 \leq \eta \leq 1$, and $0 \leq \phi \leq 2\pi$.

In oblate spheroidal coordinates, the Laplacian, ∇^2 , has the form

$$\begin{aligned} \nabla^2 f = & \frac{1}{c^2(\xi^2 + \eta^2)} \left[\frac{\partial}{\partial \xi} \left((\xi^2 + 1) \frac{\partial}{\partial \xi} \right) \right. \\ & \left. + \frac{\partial}{\partial \eta} \left((1 - \eta^2) \frac{\partial}{\partial \eta} \right) + \frac{\xi^2 + \eta^2}{(\xi^2 + 1)(1 - \eta^2)} \frac{\partial^2}{\partial \phi^2} \right] f. \end{aligned} \tag{A.4}$$

Therefore, the Helmholtz equation, $\nabla^2 f = -K^2 f$, has the form

$$\begin{aligned} \nabla^2 f = \frac{1}{c^2(\xi^2 + \eta^2)} & \left[\frac{\partial}{\partial \xi} \left((\xi^2 + 1) \frac{\partial}{\partial \xi} \right) \right. \\ & \left. + \frac{\partial}{\partial \eta} \left((1 - \eta^2) \frac{\partial}{\partial \eta} \right) + \frac{\xi^2 + \eta^2}{(\xi^2 + 1)(1 - \eta^2)} \frac{\partial^2}{\partial \phi^2} \right] f = -K^2 f. \end{aligned} \quad (\text{A.5})$$

REFERENCES

- [1] Twersky, V. (July-August 1962). On a General Class of Scattering Problems. *Journal of Mathematical Physics*, 3, 716.
- [2] Kibble, T. W. B. (1973). *Classical Mechanics*, 2nd Edition (pp 16-19). New York: Halsted Press
- [3] Morse, P. M., Feshbach, H. (1953). *Methods of Theoretical Physics*, 2 Pts. (pp. 24-44, 510). New York: MacGraw-Hill
- [4] Solakiewicz, Richard (May 1987). *Scattering by an Obstacle in a Half-Space Bounded by a Penetrable Interface*. Ph.D Dissertation, UIC
- [5] Twersky, V. (Feb 1962). Multiple Scattering of Waves and Optical Phenomena. *Journal of the Optical Society of America*, Vol. 52, No. 2.
- [6] Twersky, V. (Dec 1977). Coherent Scalar Field in Pair-Correlated Random Distributions of Aligned Scatterers. *Journal of Mathematical Physics*, Vol. 18, No. 12.
- [7] Twersky, V. (April 1966). Multiple Scattering of Electromagnetic Waves by Arbitrary Configurations. *Journal of Mathematical Physics*, Vol. 8, No. 3.
- [8] Merzbacher, Eugen (1961). *Quantum Mechanics*, 2nd Edition. (pp. 3, 5-6, 41-43, 65, 338). New York : John Wiley & Sons, Inc.
- [9] Twersky, V. (January-February 1962). Multiple Scattering by Arbitrary Configurations in Three Dimensions. *Journal of Mathematical Physics*, Vol. 3, No. 1.

- [10] Arfken, G. B., & Weber, H. J. (1995). *Mathematical Methods for Physicists*, 4th Edition (pp. 553, 565-567, 570-574, 682, 727). California: Academic Press
- [11] Jackson, J. D., (1975). *Classical Electrodynamics*, 2nd Edition (pp. 98, 767). New York: John Wiley & Sons, Inc.
- [12] Lorrain, P., & Corson, D. (1970). *Electromagnetic Fields and Waves*, 2nd Edition, (pp. 27-28). California: W. H. Freeman Company
- [13] Arfken, G. B., (1966). *Mathematical Methods for Physicists*, 1st Edition (pp. 64-110, 553, 565-567, 570-574, 682, 727). New York: Academic Press
- [14] Abramowitz, M., & Stegun, I. A. (1972). *Handbook of Mathematical Functions with Formulas, Graphs, and Mathematical Tables*, 9th Edition, (p. 752). New York: Dover.
- [15] Hildebrand, F. B. (1976). *Advanced Calculus for Applications*, 2nd Edition, (pp. 306-313). New Jersey: Prentice-Hall, Inc.
- [16] Stratton, J. A. (1941). *Electromagnetic Theory*, 1st Edition (pp. 47-59). New York: McGraw-Hill Book Company.
- [17] Flammer, C. (1957). *Spheroidal Wave Functions*, 1st Edition, (pp. 10-13). California: Stanford University Press.
- [18] Li, W. L., Kang, X. K., & Leong, M. S. (2002). *Spheroidal Wave Functions in Electromagnetic Theory* (pp. 13-60). New York: John Wiley & Sons, Inc.
- [19] Spence, R. D., and Granger, S. (November 1951). The Scattering of Sound from a Prolate Spheroid. *J. Acoust. Soc. Am.*, Vol. 23, No. 6.

- [20] Hodge, D. B., (August 1970). Eigenvalues and Eigenfunctions of the Spheroidal Wave Equation. *Journal of Mathematical Physics* Vol. 11, No. 8.
- [21] Zhou, H., and Hong, L. (July 2014). Motion of a Rigid Prolate Spheroid in a Sound Wave Field. *Journal of Mathematical Physics* Vol. 36, No. 2.
- [22] Asano, S. and Sato, M. (January 1975). Light Scattering by a Spheroidal Particle. *Journal of Applied Optics*, Vol. 14, No. 1.
- [23] Asano, S. and Sato, M. (March 1980). Light Scattering by a Randomly Oriented Spheroidal Particles. *Journal of Applied Optics*, Vol. 19, No. 6.
- [24] Kotsis, A.D., and Roumeliotis, J.A. (2008). Acoustic Scattering by a Penetrable Spheroid. *Acoustical Physics*, Vol. 54, No. 2 (pp. 189-204).
- [25] Burke, J.E., (October 1967). Scattering by Penetrable Spheroids. *The Journal of the Acoustical Society of America*, Vol. 43, No. 4.
- [26] Chu, D. and Stanton, T.K., (November 1989). Application of Twersky's Boss Scattering Theory to Laboratory Measurements of Sound by a Rough Surface. *Acoustical Society of America*, Vol. 87, No. 4.
- [27] Stratton, J.A., Morse, P.M., Chu, L.S., Corbato, F.J. (1956). *Spheroidal Wave Functions*, (pp. 43-44). New York: John Wiley and Son, Inc.
- [28] Twersky, V. (August 1983). Scattering and Nonscattering Obstacles. *SIAM J. Appl. Math.*, Vol. 43, No. 4.
- [29] Yeh, C. (1967). Scattering of Acoustic Waves by a Penetrable Prolate Spheroid. I. Liquid Prolate Spheroid. *The Journal of the Acoustic Society of America*, Vol.

42, No.2.

- [30] Okumura, T., Masuya, T., Tukeo, Y., and Sawada, K. (2003). Acoustic Scattering by an arbitrarily shaped body: an application of the boundary element method. *Journal of Marine Science*, Vol. 60, pp. 563-570.
- [31] Fischnallar, H. (September 2009). Numerical Integration-An Introduction For The Boundary Element Method. Masters Project for Graz University of Technology.
- [32] Twersky, V. (July 1962). On Scattering of Waves by Random Distributions. I. Free-Space Formalism. *Journal of Mathematical Physics* 125. Vol. 3. , No. 4.
- [33] Liu, Y. (November 2013). An Introduction to the Boundary Element Method (BEM) and Its Applications in Engineering. University of Cincinnati.
- [34] Mushtaq, M., Ali Shah, Ni, and Muhammad, G. (2010). Advantages and Disadvantages of Boundary Element Methods For Compressible Fluid Flow Problems. *Journal of American Science*. Vol. 6, No. 1
- [35] Gunda, R. (March 2008). Boundary Element Acoustics and the Fast Multipole Method (FMM). *Sound and Vibration*. pp. 12-16
- [36] Gorska, N. (Nov. 2001). Some Aspects of Sound Extinction by Zooplankton. *J. Acoustic. Soc. Am.* Vol. 110., No. 5.
- [37] Jones, B.A. , Lavery, A.C., and Stanton, T.K. (January 2009). Use of the Distorted Wave Born Approximation to Predict Scattering by Inhomogeneous Objects: Application to Squid. *J. Acoustic. Soc. Am.* Vol. 125., No. 1.

- [38] Chu, D., and Ye, Z. (October 1999). A Phase-Compensated Distorted Wave Born Approximation Representation of the Bistatic Scattering by Weakly Scattering Objects: Application to Zooplankton. *J. Acoustic. Soc. Am.* Vol. 106., No. 4.
- [39] Pruppacher, H. R., and Klett, J. D. (2003). *Microphysics of Clouds and Precipitation* (pp. 502-503). Dordrecht: Kluwer Academic Publishers.
- [40] Rakov, V. A. and Uman, M. A. (2003). *Lightning*. Cambridge University Press.
- [41] Koshak, W. J., Solakiewicz, R. J., Phanord, D. D., and Blakeslee, R. J. (1994). Diffusion Model for Lightning Radiative Transfer, *Journal of Geophysical Research*, Vol. 99, No D7, 14361-14371.

Curriculum Vitae
Graduate College
University of Nevada, Las Vegas

Joseph M. Borromeo

Local Address:

948 Rainbow Rock Street

Las Vegas, NV 89123

Degrees:

Associates of Applied Science in Business Administration, 2008

Mercer County Community College, New Jersey

Associates of Science in Business Management, 2008

Mercer County Community College, New Jersey

Bachelor of Science in Mathematics, 2011

University of Nevada, Las Vegas

Thesis title:

On the Scattering of an Acoustic Plane Wave by a Soft Prolate Spheroid

Thesis Examination Committee:

Chairperson, Dr. Dieudonne Phanord, Ph.D.

Committee Member, Dr. Amei Amei, Ph.D.

Committee Member, Dr. Rohan Dalpatadu, Ph.D.

Graduate Faculty Representative, Dr. Djeto Assane