

5-2011

## Operation span task's susceptibility to math anxiety: Support from fluid intelligence

Robert T. Durette  
University of Nevada, Las Vegas

Follow this and additional works at: <https://digitalscholarship.unlv.edu/thesesdissertations>

 Part of the [Other Psychology Commons](#)

---

### Repository Citation

Durette, Robert T., "Operation span task's susceptibility to math anxiety: Support from fluid intelligence" (2011). *UNLV Theses, Dissertations, Professional Papers, and Capstones*. 1002.  
<https://digitalscholarship.unlv.edu/thesesdissertations/1002>

This Dissertation is protected by copyright and/or related rights. It has been brought to you by Digital Scholarship@UNLV with permission from the rights-holder(s). You are free to use this Dissertation in any way that is permitted by the copyright and related rights legislation that applies to your use. For other uses you need to obtain permission from the rights-holder(s) directly, unless additional rights are indicated by a Creative Commons license in the record and/or on the work itself.

This Dissertation has been accepted for inclusion in UNLV Theses, Dissertations, Professional Papers, and Capstones by an authorized administrator of Digital Scholarship@UNLV. For more information, please contact [digitalscholarship@unlv.edu](mailto:digitalscholarship@unlv.edu).

OPERATION SPAN TASK'S SUSCEPTIBILITY TO MATH ANXIETY:

SUPPORT FROM FLUID INTELLIGENCE

by

Robert Thomas Durette

Bachelor of Arts  
University of Nevada, Las Vegas  
2006

Master of Arts  
University of Nevada, Las Vegas  
2009

A dissertation in partial fulfillment of  
the requirements for the

**Doctor of Philosophy in Psychology**  
**Department of Psychology**  
**College of Liberal Arts**

**Graduate College**  
**University of Nevada, Las Vegas**  
**May, 2011**

Copyright by Robert Thomas Durette 2011  
All Rights Reserved



**THE GRADUATE COLLEGE**

We recommend the dissertation prepared under our supervision by

**Robert Thomas Durette**

entitled

**Operation Span Task's Susceptibility to Math Anxiety: Support from Fluid Intelligence**

be accepted in partial fulfillment of the requirements for the degree of

**Doctor of Philosophy in Psychology**

Mark H. Ashcraft, Committee Chair

David E. Copeland, Committee Member

Joel S. Snyder, Committee Member

Gabriele Wulf, Graduate Faculty Representative

Ronald Smith, Ph. D., Vice President for Research and Graduate Studies  
and Dean of the Graduate College

**May 2011**

## ABSTRACT

### **Operation Span Task's Susceptibility to Math Anxiety: Support from Fluid Intelligence**

by

Robert Thomas Durette

Dr. Mark H. Ashcraft, Examination Committee Chair  
Professor of Psychology  
University of Nevada, Las Vegas

This experiment tested possible math anxiety effects on the two most prominent working memory span tasks, the operation span and reading span tasks. Math anxiety effects on the performance of the processing component of the operation span task, which is math based, were found, but not on the processing component of the reading span task, which is reading based. High math anxious individuals were the largest group of individuals that failed to meet the prescribed 85% accuracy threshold of the processing component of the operation span, countering the hypothesis that not meeting the threshold score is due to a lack of motivation. Math anxiety groups did not differ in working memory capacity (i.e., storage component of the operation span task, processing and storage components of the reading span task) or fluid intelligence (i.e., RAPM and PMA number series performance), further supporting theories that high math anxious individuals do not differ from others in working memory capacity and that they should not be removed from experimental analyses due to the failure to meet the prescribed 85% threshold of the processing component of the operation span task.

## ACKNOWLEDGEMENTS

I would like to thank my committee members: Dr. David Copeland, Dr. Joel Snyder, and Dr. Gabriele Wulf. Your input in the proposal, data collection and write up is appreciated. I felt I could seek your guidance throughout the process. I want to also say thank you to my math cognition lab partners: Jeremy Krause, Michelle Guillaume, Alex Moore, Nathan Rudig, and Ricardo Rios. Much of this was a team effort and I thank you each for your help in completing it.

I want to take the opportunity to say a special thanks to my committee chair and advisor over the last five years, Dr. Mark Ashcraft. The edits were sometimes painful, but always helpful. Your thoughtfulness and calming influence helped me get through a number of instances when my results were panic invoking. I am still thankful that you let me join your lab.

To Lisa, whose idea it was to get a Ph.D. in the first place, thank you for believing in me (and sort of supporting me along the way). I don't know what this validates more: me or your choosing me as your husband. Thank you for going through the process with me, it would not have been possible without you.

To my grandmother who always called me her little professor, and mom and dad who instilled in me a love of reading, I hope this makes you proud.

Finally to Alli, I hope that one day when you are older you will read this and realize that you can do anything that you strive for in life. If daddy can do this, you can do so much more.

## TABLE OF CONTENTS

ABSTRACT .....	iii
ACKNOWLEDGMENTS .....	iv
CHAPTER 1 INTRODUCTION .....	1
Reading Span (Rspan) .....	4
Operation Span (Ospan) .....	7
Working Memory Span Task Conclusion .....	9
Math Anxiety .....	10
Fluid Intelligence .....	15
Number Series .....	15
Raven’s Advanced Progressive Matrices (RAPM) .....	19
Fluid Intelligence and Working Memory .....	23
Introduction Conclusion .....	25
CHAPTER 2 METHOD .....	27
Participants .....	27
Instruments .....	27
CHAPTER 3 RESULTS .....	32
Structural Equation Model Results .....	32
Span Task Overall Results .....	33
Span Task Processing Component Performance and Math Anxiety .....	35
Math Anxiety Effects due to Math Ability .....	36
Span Task Storage Component Performance and Math Anxiety .....	37
Span Task Threshold Results .....	39
Fluid Intelligence Measures and Math Anxiety .....	44
CHAPTER 4 DISCUSSION .....	46
APPENDIX 1 TABLES AND FIGURES .....	54
APPENDIX 2 OPRS APPROVALS .....	68
APPENDIX 3 BIBLIOGRAPHY .....	69
APPENDIX 4 VITA .....	82

## CHAPTER 1

### INTRODUCTION

This experiment tested for possible math anxiety effects on the two most prominent working memory span tasks, the operation span (Ospan) and reading span (Rspan) tasks. The Ospan task has a math based processing component while the Rspan task has a reading based processing component. It was hypothesized that math anxiety will affect performance on the processing component of the Ospan task, but not the Rspan task. The results of this hypothesis not only have an impact on future research on the construct of working memory, but also on any past experiments that used Ospan task performance as an inclusion criterion. Current working memory literature (Conway, Kane, Bunting, Hambrick, Wilhelm, & Engle, 2005) prescribes that participants score at least an 85% accuracy rate on the processing component in order to be included in experimental analyses. It was hypothesized that the majority of individuals that fail to meet the prescribed 85% accuracy threshold of the processing component of the Ospan task will have a high level of math anxiety, countering the hypothesis that not meeting the threshold score is actually due to a lack of motivation (Turner & Engle, 1989), and that those high math anxiety individuals do not differ in working memory capacity (i.e., storage component of the Ospan task, processing and storage components of the Rspan task) or fluid intelligence (i.e., Raven's Advanced Progressive Matrices (RAPM; Raven, Raven, & Court, 1998) and Thurstone's PMA number series performance (Thurstone & Thurstone, 1938; 1962)). The implication of this result is that previous researchers using the Ospan task as instructed by the Ospan task creators biased their sample in an unwanted manner by removing high math anxious, not low motivated or low working



memory capacity individuals. Specifically, researchers would be removing half of all high math anxious individuals or 10 to 15% of the entire population due to their math anxiety, which would directly increase data collection time and cost, and shrink the pool of possible participants. Additionally, this result will further support theories that high math anxious individuals do not differ from others in working memory capacity, despite their poor performance on the processing component of the Ospan task, and that these individuals should not be removed from experimental analyses due to their failure to meet the prescribed 85% threshold. Math ability was also tested to determine if online interference or long term avoidance, two hypotheses of the process of the effects of math anxiety, is the more likely culprit for decreased performance.

Psychologists have created many tasks to measure working memory, one of the earliest being Daneman and Carpenter's (1980) Rspan task. Span tasks, as they are now known, are actually made up of two separate tasks that are completed in parallel: a processing task and a storage task. It is theorized that these two tasks, when completed together, reveal an individual's working memory capacity or span. In effect, working memory span tasks tell researchers the amount of information a person can store and successfully recall while at the same time completing some other "processing" task. This is analogous to everyday tasks that people are faced with: holding a number of pieces of information in memory that may or may not be needed to solve a problem while at the same time completing some other separate task. One's proficiency in completing a span task has proven to predict performance on other cognitive (Daneman & Carpenter, 1980; Engle, 2002; Masson & Miller, 1983; Turner & Engle, 1989), social (Schmader & Johns,

2003), academic (Engle Tuholski, Laughlin, & Conway 1999), and intelligence (Conway, Cowan, Bunting, Theriault, & Minkoff, 2002) tests.

The construct of working memory has its roots at the beginning of cognitive psychology and George Miller's suggestion that we have the ability to maintain 7 plus or minus 2 items in memory at any one time (Miller, 1956). This ability is now called short term memory. Early in the study of short term memory, many tasks were created to measure the number of items that individuals could store and recall. Simple span tasks of different sorts, some using words, some using letters, were used by Baddeley and others (Baddeley, 1986; Baddeley & Hitch, 1974) to coin the term working memory and develop a theory that we have different components within our working memory that maintain and process different types of stimuli. Daneman and Carpenter (1980) and others (Baddeley & Hitch, 1974) suggested that a task made up of solely storage and recall was not sufficient to determine an individual's working memory capacity. They suggested a two component task, one with storage and recall accompanied by a processing requirement. This new span task, sometimes called a complex span task to differentiate from the earlier simple span tasks that just required storage and recall, was found to correlate highly with reading comprehension (Daneman & Carpenter, 1980). Subsequent experiments using Daneman and Carpenter's complex span task (i.e., Rspan task) and other similar complex span tasks have been found to relate to performance on many other, seemingly unrelated tasks.

Researchers (Conway et al., 2005) suggest that the current working memory span tasks, such as the Ospan and Rspan tasks, are not domain specific, but actually tap into domain general executive attention and control. In fact, many authors have made the

claim that there is no distinction between types of working memory capacities (Cantor, Engle, & Hamilton, 1991; Conway et al., 2005; Turner & Engle, 1989). While this may be true, aspects of and context of the span tasks may elicit individual differences that have profound effects on one's span task score, as Conway, Kane, Bunting, Hambrick, Wilhelm, and Engle (2005) explained: "For example, the operation span task measures WMC but, most likely, also taps mathematical ability, motivation, and word knowledge, among other factors." This is the central argument of this paper: aspects (i.e., mathematical versus reading processing components) of working memory span tasks have differential effects on individuals, such that their overall working memory span is not correctly measured.

### Reading Span (Rspan)

One of the first working memory span tasks was Daneman and Carpenter's (1980) Rspan task, which required participants to read a sentence while at the same time remember and subsequently recall the last word of each sentence. The authors created 3 sets of 2, 3, 4, 5, and 6 sentences that required participants to recall the last words of the sentences for each set in the order they were presented. The person's working memory span was the level at which 2 of the 3 words were correctly recalled. In other words, an individual's working memory capacity or span was between 2 and 6.

In Daneman and Carpenter's (1980) second experiment they added a true-false response requirement to the reading aspect of their working memory span task. Participants indicated whether the sentences, drawn from general knowledge materials, were true or not within 1.5 seconds. This additional step's purpose was to prevent

participants from using a strategy of ignoring the content of the sentences in order to focus working memory resources on word storage for recall but, Daneman and Carpenter (1980) failed to record the accuracy of the sentence verification aspect of the Rspan task. Turner and Engle (1989) rectified that and imposed an 80% cut off score for inclusion in analysis, although they failed to report the performance on the processing component of the Rspan or the Ospan task. Similar to Daneman and Carpenter (1980), Turner and Engle's focus was on storage component performance to determine one's working memory capacity. Subsequently, the 80% threshold was increased to the current standard of 85% accuracy on the processing component of the Ospan task (Conway, et al., 2005; Engle & Conway, 1996; Engle, Tuholski, Laughlin, & Conway, 1999).

Another alteration to the Rspan task was the addition of a separate word used for recall that is different from the last word in the processing component's sentences. After reading the sentence and verifying whether it followed syntax and grammar rules, a separate word, different from any word in the sentence is shown to the participant. This separate word is the one that is required for later recall. In another version of the Rspan task, isolated letters are required for recall, replacing individual words that follow sentence verification (Kane, Hambrick, Tuholski, Wilhelm, Payne, & Engle, 2004).

An untested concern of Daneman and Carpenter (1980; 1983) was that reading ability, which is required to read the sentences, would affect the sentence based Rspan task performance. Daneman and Carpenter hypothesized that an individual with a higher level of reading ability would be able to read the sentences of the processing component faster and free up time during the task for rehearsal of the to be recalled words. This may inflate a participant's working memory span. Applying this concern to the math based

Ospan task is central to this paper: math ability and math anxiety may influence Ospan task performance, such that the results are not a valid measure of one's working memory span/capacity.

Turner and Engle (1989) updated Daneman and Carpenter's (1980) Rspan task by lowering the number of words to be recalled from 15 to 12 and altered the sentence (i.e., processing task) aspect from a general knowledge test to a test of whether the sentences were semantically and syntactically correct. In addition to these two primary changes, Turner and Engle (1989) also changed the sentence reading from self-paced to a experimenter-paced administration to combat any individual differences in reading proficiencies that participants may have. Turner and Engle also tested one of Daneman and Carpenter's hypotheses that a rapid reader would be able to free time for more last word rehearsal opportunities, thereby increasing word recall. But, Turner and Engle's (1989) results suggested that reading comprehension ability did not assist in the processing or the word recall component of the Rspan task. The possibility of individual differences affecting performance on the processing component is also central to this paper: anxiety elicited by situations consisting of arithmetic may affect performance on the processing (i.e., arithmetic) component of the Ospan task.

A current hypothesis about how math anxiety affects arithmetic performance is that working memory resources are consumed by intrusive thoughts elicited by math situations (Ashcraft & Kirk, 1998; 2001; Kellog, Hopko, & Ashcraft, 1999). This math anxiety hypothesis would have a direct impact on a math based instrument's performance that is measuring working memory span. However, as the Rspan task is not a math based

measure of working memory capacity, there should be no decrease in performance for high compared to low math anxious individuals.

### Operation Span (Ospan)

The Ospan task was created by Turner and Engle (1989) as a counterpart to the Rspan task and sought to show that working memory was not a domain specific, but a domain general construct. The Ospan task mirrored the construction of the Rspan task, but replaced sentence verification with the verification of a mathematical equation. By finding no differences in performance between the math and reading based working memory span tasks, Turner and Engle's results supported the theory that the working memory span construct was domain general.

Currently, the Ospan task is similar to the Rspan task in that it consists of a processing and storage component. The processing component of the Ospan task requires individuals to verify whether a mathematical equation is correct. The equation follows a consistent formula: multiplication or division of 2 single digits and the addition of a third single digit (i.e.,  $(6 / 3) + 3 = 5$ ). Participants respond with y or n as to whether the equation is correct. A single syllable word is subsequently presented for later recall. Set size emulates the Rspan task with 2, 3, 4, 5, 6 sets of equation verifications and word presentations prior to word recall.

Conway and Engle (1996) altered the difficulty of the arithmetic operation of the processing component of the Ospan task and found that it did not affect the performance on the storage component. Participants completed the Ospan task with both single and two digit addition or subtraction verification problems (i.e., easy condition) or more

difficult single and two digit multistep arithmetic verification problems that involved both multiplication, division and addition and subtraction. The increase in difficulty of the processing component did not decrease performance on the storage component, further supporting a theory that the processing component is secondary and that the storage component is actually measuring working memory capacity/span (Conway & Engle, 1996; Engle, Cantor, & Carullo, 1992; Turner & Engle, 1989). Conway and Engle's (1996) results support the claim of this paper, that math anxiety's possible effects on the arithmetic processing component of the Ospan task should not eliminate individuals with high levels of the math anxiety from inclusion in analyses, as processing component performance does not necessarily reflect working memory capacity.

Researchers have found math anxiety effects on the performance of simple arithmetic problems, such as the simple arithmetic of the processing component of the Ospan task, in specific conditions (Ashcraft & Krause, 2007; Faust, Ashcraft & Fleck, 1996). Performance on similar, but untimed simple arithmetic problems, such as the problems that make up the first three lines of the Wide Range Achievement Test – 3, Arithmetic (WRAT-3), have not been found to be affected by math anxiety (Ashcraft & Krause, 2007). However, Faust et al., (1996) did find accuracy decreased for high math anxiety individuals on timed simple arithmetic problems in comparison to the same untimed problems. Similarly, the processing component of the Ospan task has a 5 second time constraint that may elicit math anxiety effects (i.e., a decrease in accuracy). This additional aspect of the Ospan task may require enough working memory resources that there is a competition between task completion and math anxiety's intrusive thoughts. This competition may cause a decrease in processing or storage task performance that

may be associated with a specific set size. In other words, individuals with high math anxiety may have a decrease in equation verification accuracy in set sizes 4, 5 and 6, but individuals with low math anxiety may exhibit a decreased performance in equation verification only in set 6. This may indicate the specific amount of working memory resources that math anxiety consumes, depending on one's level of math anxiety.

### Working Memory Span Task Conclusion

This experiment will test the effects of math anxiety on the two most prominent working memory span tasks, the Ospan and Rspan tasks. Research below supports a hypothesis that math anxiety will affect performance on the processing component (i.e., the math based portion of the Ospan), but not the storage component of the Ospan task and neither the processing or storage component of the Rspan task. This hypothesis is based on research that indicates high math anxiety individual's working memory is consumed by intrusive thoughts surrounding math situations (Ashcraft & Kirk, 1998; 2001; Kellog, Hopko, & Ashcraft, 1999). Differing scores between the processing components of the Ospan and Rspan tasks could be due to a number of reasons, such as math anxiety, math ability or possibly lower general cognitive ability (i.e., lower fluid intelligence). To determine if math ability or fluid intelligence may explain different scores on the two span tasks, two fluid intelligence measures (i.e., RAPM and the PMA number series) and a math ability test (i.e., WRAT-3) will be administered. A lack of difference on these additional measures (e.g., PMA number series, RAPM, and WRAT-3) will further support the hypothesis that math anxiety is a cause for poor performance on



the processing component of only the Ospan and that the individuals that do not meet the 85% threshold should not be removed from further analyses.

### Math Anxiety

Math anxiety is a condition that arises when individuals are faced with a situation dealing with numbers or arithmetic resulting in apprehension, anxiety or feelings of fear and primarily affects people's ability to perform mathematical tasks, but also has effects on other aspects of individual's lives. There are two theories, not mutually exclusive, as to the effects of math anxiety. The first theory is one of avoidance, both short-term, in the moment avoidance and long-term avoidance such as taking fewer math classes. A second theory of math anxiety effects deals with online competition for working memory resources.

An individual with high levels of math anxiety may just want to escape a math situation such as a math test, as quickly as possible, with no care as to their grade or the accuracy of their answer (Faust et al., 1996). This is evident in math cognition research that has shown speed-accuracy tradeoff results for individuals with high levels of math anxiety, but this attempt to quickly complete a math task with little regard for accuracy is not present for similar math ability individuals that do not have high levels of math anxiety (Faust et al., 1996).

Math anxiety may also lead individuals to avoid situations that range from simple mathematical tasks to selecting math courses of study. Individuals may become less skilled in math due to avoidance, less practice and performing fewer mathematical problems in academic and real world situations. A meta-analysis of math anxiety

research showed a negative correlation between math anxiety and various academic measures: a  $-.31$  correlation between math anxiety and number of high school math classes enrolled and a  $-.32$  correlation between math anxiety and college math courses enrolled (Hembree, 1990). This lack of classroom participation may compound one's already poor math performance and increase an individual's math anxiety. Math anxiety is widespread across the population with an estimated 17% of the population classified as being high math anxious (Ashcraft, Krause, & Hopko, 2007).

Another theory that may explain math anxiety effects is Eysenck and Calvo's 1992 processing efficiency theory. Eysenck and Calvo's (1992) results showed that higher levels of general anxiety decreased individuals' performance on a secondary task requiring working memory resources. This model was applied to math cognition and math anxiety by Ashcraft and Faust (1994), who found that an individual with math anxiety has competition in working memory between the intrusive thoughts of worry and fear about math anxiety and completing the actual math task. This competition for limited mental resources resulted in longer reaction times and/or inaccuracies (Ashcraft & Faust, 1994).

However, math anxiety effects are not associated with all math problems. Simple arithmetic problems, such as single digit addition or multiplication problems, are theorized to be completed using retrieval instead of more cognitively intense processes (for a review, see Ashcraft, 1995). Simple math problems are not associated with a speed-accuracy tradeoff (i.e., longer reaction times or higher error rates in individuals with high math anxiety (Lefevre, DeStefano, Coleman, and Shanahan, 2005; Sietz, Schumann-Hengsteler, 2002)). This lack of differentiation among math anxiety groups

may be due to the simplistic nature of the math task which requires very little working memory resources (De Rammelaere, 1999; De Rammelaere, Stuyven, and Vandierendonck, 2001; De Rammelaere and Vandierendonck, 2001).

In Ashcraft and Kirk's (2001) task, participants were faced with a dual task situation made up of a primary (i.e., processing) task of two-column addition problems (half with a carry function and half without a carry function) and a secondary (i.e., storage) task of holding two or six letters in working memory for later recall. The problems with a carry operation were especially important due to the increased working memory requirements for successful completion (LeFevre, DeStafeno, Coleman, and Shanahan, 2005). This required a participant to maintain two or six letters in working memory while at the same time completing an addition problem. Maintaining the set of letters in working memory decreases the amount of working memory resources that an individual has to complete the mathematical operations. An individual with high math anxiety would have even more competition for their limited working memory resources from their math related intrusive thoughts and fears.

Ashcraft and Kirk (2001) found that the increase from two to six letter sets and math problems with a carry operation increased error rates. Specifically in experiment 2, error rates increased from 10% for low math anxious individuals to greater than 27% for high math anxious individuals completing the 6 letter condition with problems that required carrying. These results indicate that math anxiety is competing with letter rehearsal/recall and math operations for working memory resources. Ashcraft and Kirk's (2001) dual task experiment's stimuli is similar to the Ospan task in that they both

required participants to complete arithmetic operations while at the same time store and recall non-numerical information.

A widely used instrument for the assessment of math anxiety (Ashcraft & Kirk, 2001; Ashcraft & Moore, 2009; Beilock, Gunderson, Ramirez, & Levine, 2010; Faust et al., 1996; Hopko, Ashcraft, Gute, Ruggiero, & Lewis, 1998; Kellog Hopko & Ashcraft, 1999) is the shortened Math Anxiety Rating Scale (sMARS). The sMARS has been selected to measure math anxiety in part due to its quick and easy administration, and that it covers three academic areas: feelings, studying for math tests, and actually completing math homework and tests. The sMARS originated from a longer scale created by Richardson and Suinn in 1972. Richardson and Suinn (1972) called their scale the Math Anxiety Rating Scale (MARS), which consisted of 98 items that asked subjects about their feelings involving situations that require mathematics. Participants rated their level of anxiety in various situations using a five point Likert-type scale with results having a reliability of .85 (Brush, 1978). Richardson and Suinn's (1972) MARS was shortened from 98 to 25 items by Alexander and Martray in 1989 and was titled the shortened Math Anxiety Rating Scale (sMARS). The shortened scale was studied by Fleck, Sloan, Ashcraft, Slane, and Strakowski in 1989 and found to have a mean score of 35.0, standard deviation of 16.0, and correlated with the original MARS at .96. The mean and standard deviation of the sMARS has been used to create 3 math anxiety groups: low, medium and high (Ashcraft & Kirk, 2001), allowing for extreme groups comparisons. Individuals that score less than one standard deviation below the grand mean on the sMARS are classified as low math anxious, individuals that score with half a standard deviation above or below the grand mean on the sMARS are classified as medium math

anxious and individuals that score greater than one standard deviation above the grand mean on the sMARS are classified as high math anxious.

The WRAT has a history of being used to determine math ability in the research of math anxiety (Ashcraft & Kirk, 1998; 2001; Ashcraft & Krause, 2007). Specifically, Ashcraft and Krause (2007) found that high math anxious individuals perform similarly on items in the first half of the 40 item test, but separate themselves on items later in the test with a much lower accuracy rate. The literature has age and grade appropriate norms that can be used for math achievement comparisons (Wilkerson, 1993).

There are two theories of math anxiety effects on math performance. One theory states that math anxiety hampers performance on math tasks by consuming working memory resources through intrusive thoughts and the other states that individuals with high math anxiety are poor at math due to a lifelong avoidance of math situations such as academic arithmetic classes. Math anxiety is expected to differentially affect the processing component of the two span tasks, one being math based and the other reading based.

To find support for the two theories of math anxiety, online interference or long term avoidance of math related situations, participants' math ability and math anxiety levels will be measured. For example, a participant with high math anxiety and high math ability that performs poorly on the processing component of the Ospan task would be exhibiting the effects of online interference. An individual that has high math anxiety and low math ability that performs much worse on the processing component of the Ospan task than the Rspan task does not necessarily disprove the online interference theory, but does lend some support for the avoidance theory of math anxiety.

## Fluid Intelligence

Fluid intelligence is a psychological construct that predates working memory. One of the first scientific attempts at defining the construct of intelligence was Spearman's designation of "g" (1904; 1927), or general intelligence. Spearman originally defined g as the underlying relationship between the performance on multiple academic (i.e., spelling, reading, and mathematics) tests (Jensen, 1987). For example, people's general intelligence would be reflected by the correlation between their performances on tests of different subject matters. Each test's results would reflect that person's experience and recall of information specific to that subject, but the shared variance between the tests would reflect an underlying level of cognitive ability. This cognitive ability would aid in performing any task or test, no matter the specific domain of the current task. This is the basis for Spearman's definition of general intelligence. Now the term "g" is interchangeable with general intelligence (Raven et al., 1998) and is thought to relate to multiple real world behaviors (cf. Gardner, 1983), such as academic achievement (Brand, 1987; Kuncel, Hezlett, & Ones, 2001) and job performance (Gottfredson, 1997; Lubinski, Webb, Morelock, & Benbow, 2001; Ree & Caretta, 1998; Schmidt, 2002). The two most frequently used tasks that determine fluid intelligence are the PMA number series and RAPM.

## Number Series

The PMA number series instrument is a test of fluid intelligence and has been used in recent years to show the close relationship between fluid intelligence and working memory capacity (Ackerman, Beier, & Boyle, 2002; Unsworth, 2010a; Unsworth &

Spillers, 2010). In this experiment, performance on the PMA number series and RAPM will be used to form a fluid intelligence factor, similar to the manner in which current working memory researchers use the performance on these two instruments (Unsworth & Spillers, 2010). It is hypothesized that not every item of the PMA number series requires an arithmetic operation to solve.

The PMA number series completion tasks are arithmetic tests that require a person to determine the next number in a series of digits (e.g., 2 4 6 8 ?). The PMA number series have long been used in standardized tests to determine individuals' scholastic aptitude (e.g., SAT), intelligence (e.g., Thorndike and Hagen's Cognitive Abilities Test (CAT), 1971; Thurstone and Thurstone's PMA number series, 1938; 1962) problem solving and domain specific (e.g., arithmetic) knowledge (e.g., GRE). The PMA number series completion is a useful instrument to measure fluid intelligence, math ability and working memory capacity due to the many operations and relations that can be manipulated within the task. While using familiar and basic stimuli such as numbers, a varied number of mathematical operations can be used to form the relationship within the presented sequence or pattern. Not only are individuals attempting to discern or induce the relationships (i.e., rules) between the numbers, but they also must maintain these rules in working memory and apply them to determine the unknown digit (i.e., answer). Depending on the manipulations within a number series item, the item may require domain specific knowledge (i.e., number values, number relationships, and arithmetic operations) and domain general abilities (i.e., pattern detection and progression, and working memory capacity for maintenance of domain specific information).

Number series tasks require an individual to continue the sequence of numbers that they are shown. For example, the completion of the pattern “2 3 4 ?” is 5. Each number in the sequence is 1 digit higher than the previous (i.e., 2 to 3 to 4). The continuation of this pattern past 4 leads to the correct response of 5. This example is one of simple, one-step addition; however, other operations can be used such as subtraction, multiplication, and division. These operations can also be mixed together within one sequence or trial. Here is an example of a sequence with more than one operation: “2 3 6 7 14 ?”. Here, the correct answer would be 15. The relationship between 2 and 3 is an addition of 1 digit, but the relationship between 3 and 6 is a multiplication of 3 times 2 (which was ambiguous, but became clear and certain later in the sequence), the relationship between 6 and 7 was again an addition of 1 and the relationship between 7 and 14 was the same as 3 and 6, a multiplication of the former digit by 2. Finally, applying the discovered rules gives us the correct response to this pattern as 15, or adding 1 to the previous digit of 14. As you can see above, problems with more than one operation require more numbers given to the test taker to disambiguate the possible operations that make up the complete pattern.

Holzman, Pelligrino and Glaser (1983) also found that the number series’ working memory demands (i.e., the number of items that must be maintained and manipulated in working memory) explained the largest amount of variance compared to all other manipulations. They found that working memory load was an important factor in number series performance and that working memory capacity, as determined by backward digit span performance, correlated positively with performance on the items that had a higher working memory load. Holzman et al. (1983)’s other findings indicated that other



problem features, such as period (i.e., how many numbers within the sequence are needed to form the rule or relationship) and sequence length (i.e., how many numbers are in the sequence), were not as related to accuracy as the number of items that must be maintained in working memory.

In addition, since this particular PMA number series has not been tested for its sensitivity to math anxiety, math anxiety groups' performance on the PMA number series will also be compared. Similarly, the relationship between PMA number series performance and math ability (i.e., WRAT-3 performance) will also be tested. Pilot studies have not shown that math anxiety or math ability affects performance on the PMA number series instrument, but it is hypothesized that this is due to the administration method, in which participants are only given 4.5 minutes to complete the 15 number series items that make up the PMA number series. In pilot studies, very few participants have been able to complete all 15 items within the time limit, which made analyses of the final problems impossible. In the proposed experiment, administration of the PMA number series will include the widely used instructions stating a 4.5 minute time limit, but allow participants to complete all of the PMA number series items. In other words, the instructions at the beginning of the task will state that there is 4.5 minutes to complete all the items of the task. While participants complete all 15 items of the PMA number series a timer will record the number of items completed within the 4.5 time limit without signaling participants as they are working. Separate analyses will be performed for problems that were completed within the time limit and performance on all 15 problems with no time limit. In this proposed experiment, performance on the PMA number series task will be used in a number of different ways, but most importantly coupled with

RAPM performance as a fluid intelligence factor. It is hypothesized that individuals with math anxiety not only have similar working memory capacities as individuals that do not have math anxiety, but that they have similar levels of fluid intelligence (i.e., similar performance on the RAPM and PMA number series). If high math anxious individuals score similarly on the RAPM and PMA number series, it would further support that high math anxious individuals that do not meet the 85% threshold on the processing component of the Ospan task should not be removed from experimental analyses. In other words those individuals that do not meet the 85% threshold are no different than those that do in two prominent cognitive constructs, working memory capacity and fluid intelligence.

#### Raven's Advanced Progressive Matrices (RAPM)

The RAPM is the second measure of fluid intelligence to be used in this experiment. It also has been used by working memory researchers to test working memory capacity's relationship to fluid intelligence, alone (Kane, et al., 2004; Mogle, Lovett, Stawski, & Sliwinski, 2008; Unsworth & Engle, 2005) and forming a fluid intelligence latent factor with Thurstone's PMA number series (Ackerman et al. , 2002; Unsworth, 2010a; Unsworth & Spillers, 2010). The RAPM is a counterpart to the PMA number series as the Rspan task is to the Ospan task. The RAPM and PMA number series are measures of fluid intelligence and the Ospan and Rspan tasks are measures of working memory capacity. The PMA number series task and Ospan task are number based and the RAPM and Rspan task are not. RAPM performance (i.e., fluid intelligence) will be compared between individuals that meet and exceed the 85% threshold for the processing

component of the Ospan and those that do not. It is hypothesized that high math anxious individuals that do not meet the 85% threshold do not differ in levels of fluid intelligence and these people would not score as poorly on a non-math based measure of working memory capacity.

The original Raven's Standard Progressive Matrices (SPM) test (1939) was created to assess one of the two components that make up intelligence, eductive ability (Raven, 1962; Raven et al., 1998). This component is now widely called fluid intelligence with the other component called either reproductive ability (Spearman, 1927) or crystallized intelligence (Cattell, 1963). Crystallized intelligence is thought to tap previously learned, semantic knowledge (Cattell, 1963) while fluid intelligence would be an individual's ability to correctly respond to a new, novel task (Cattell, 1971). Domain specific, recitation, or reproduction tests may be able to determine a person's crystallized intelligence; however, a test of fluid intelligence would need to involve stimuli that the test taker had not been exposed to or completed before (Raven et al., 1998). Tests of fluid intelligence should not be made up of language, grammar, arithmetic or number knowledge (Raven, 1962), or else prior levels of experience with these domains would affect the test results. Because of these limitations, Raven's matrices (i.e., test items) are not made up of words or numbers. However, other tests of fluid intelligence are made up of multiple domain specific tests, such as the PMA number series (Thurstone, 1938; 1962).

Raven's set of progressive matrices have long been thought of as the singular test of an individual's "g" or general intelligence (Jensen, 1980; Spearman, 1946; Vernon & Perry, 1949). It was originally created by Raven (1939) in an attempt to better capture g

as opposed to using the correlation of performance on multiple instruments. During the last 70 years, the original test (SPM, Raven, 1939) has been expanded (Coloured Progressive Matrices (CPM), Raven, 1947) and has increased in difficulty (Advanced Progressive Matrices, Raven, 1947). There have been revisions, such as the re-sequencing and shortening from 48 items to 36 items to make the latest version of the RAPM in 1962. Additional items have been created to make second versions of both the CPM and the SPM.

Two sets of geometric figures make up the RAPM. Set I is predominantly treated as a practice set and Set II as the test set. Set I is made up of 12 total items and Set II is made up of 36 items. Each item consists of the three rows of three figures each. The third figure from the left (i.e., the third figure in that row) on the bottom (i.e., third) row is blank and is the figure that the test taker must select, from a set of 8 options, to complete the array. Below the three by three array is a set of figures that are the options that can be used to “replace” the blank figure and constitute the test taker’s response to the item. The possible answers are similar figures as the above and are arranged in two rows of four figures each and are numbered 1 to 8. The figures within the items have different characteristics, such as lines (solid or dashed), shapes (squares, circles, triangles, etc.), shadings, or hatchings. These characteristics change from one figure to the next, in a progression. Sometimes the change involves different shadings, hatchings, one shape transitioning to another, thickening or thinning of interior and/or exterior walls. The answer figures have similar characteristics, but with only some of the characteristics needed for a correct response, but not all (i.e., 7 of them are lures). The RAPM requires the test taker to study the parts of individual figures and their whole, mentally construct

rules about the figure's characteristics, maintain these complex pieces of information in memory, then compare each of the eight possible answers at the bottom of the page with all the rows of figures at the top of the page, while making decisions as to the importance of each characteristic at each step. Many cognitive abilities are needed to complete the matrices: difference detection, decision-making, an amount of working memory capacity, and motivation; all adding up to fluid intelligence, or the ability to solve new, never before seen tasks.

Carpenter, Just and Shell (1990) found that five rules that can be used to correctly answer the items of the RAPM: (1) constant in a row: the characteristic is found in all the figures of that row, but changes from the first column to the second and third, (2) quantitative pairwise progression: a characteristic of the figure has an increases or decreases from one figure within an item to another, (3) figure addition or subtraction: one figure is added or subtracted to another figure to create a third, (4) distribution of three values: three characteristics are distributed (or in each figure) in a row, (5) distribution of two values: same as rule 4, but a third figure in the row does not have the characteristic. It should be noted that items in the RAPM are not restricted to only one of the above rules; some items may have figures that use one or more of the above rules. The authors, using a simple regression, found that the total number of rules found in an item accounted for 57% of the variance in errors.

Carpenter, Just and Shell (1990), in addition to studying possible rules used to complete RAPM items, the authors also analyzed item difficulty. They found that mean reaction times correlated positively with errors,  $r = .87$ , meaning that more difficult problems took longer than easier ones. The final items of set II of the RAPM (i.e., item

36, 83% error rate; item 29, 75%; item 32, 75%; and item 35, 67%) were found to be the most difficult. The more difficult items needed people to recognize and apply at least two rules to complete them, with item 36 requiring all five rules (Carpenter, et al. 1990, appendix).

### Fluid Intelligence and Working Memory

Many researchers have investigated the relationship between working memory capacity and fluid intelligence and found that performance on different working memory span tasks has significantly correlated with fluid intelligence measures (Ackerman et al., 2002; Conway, Cowan, Bunting, Theriault, & Minkoff, 2002; Engle, Tuholski, Laughlin, & Conway, 1999; Kyllonen & Christal, 1990; Mogel, Lovett, Stawski, & Sliwinski, 2008). Current working memory models hold that it is domain general to varying degrees (i.e., Baddeley, 1986; Engle & Kane, 2004; cf. Shah & Miyake, 1996) and is similar to fluid intelligence (Cattell, 1961; Spearman, 1904; 1972). Each of these constructs, working memory capacity and fluid intelligence, would aid in completing a task no matter the specifics of the stimuli or problem. While all agree that there is a relationship between working memory capacity and fluid intelligence, proponents of specific working memory theories have continued to parcel out which of the underlying subcomponents of working memory (i.e., attention versus secondary memory, Unsworth & Spillers, 2010; simple versus complex memory spans, Unsworth & Engle, 2006; short-term memory capacity and processing speed, Conway et al., 2002; primary versus secondary memory, Mogle, Lovette, Stawski, & Sliwinski, 2008) accounts for more or less of the variance in fluid intelligence.

Unsworth and Spillers (2010) performed a structural equation model (SEM) of the relationship between attentional control, working memory capacity (WMC), secondary memory and fluid intelligence. They found a significant direct effect of .53 between the latent variable of working memory capacity derived from three span tasks and the fluid intelligence latent variable of three intelligence instruments. Unsworth and Spillers (2010) chose the widely used Rspan and Ospan tasks in conjunction with the symmetry span task. All three span tasks have a processing component (i.e., Ospan task: verify the solution to a two step arithmetic problem; Rspan task: determine if a sentence makes sense; symmetry span task: determine if the coloring of an array of blocks was symmetrical) and a storage component (i.e., Ospan task: recall words displayed after each math problem; Rspan task: recall letters shown after each sentence; symmetry span task: recall sequence of illuminated blocks shown after each symmetrical verification). Unsworth and Spillers (2010) used the RAPM (Raven et al., 1998), PMA number series task (Thurstone, 1938; 1962), and a verbal analogy task to make up a fluid intelligence latent variable and found a strong correlation between WMC and fluid intelligence, supporting earlier WMC and fluid intelligence research. A significant correlation,  $r = .30$ ,  $p < .05$ , was found between performance on the RAPM and PMA number series task, which indicates their moderate relationship.

The RAPM (Raven et al., 1998) and PMA number series (Thurstone, 1938; 1962) are two instruments that are used separately (Kane, et al., 2004; Mogle, Lovett, Stawski, & Sliwinski, 2008; Unsworth & Engle, 2005) or together (Ackerman et al., 2002; Unsworth, 2010a; Unsworth & Spillers, 2010) to determine a person's fluid intelligence. This experiment will test whether individuals that fail to reach the prescribed (Conway et al.,

2005) 85% threshold on the processing component of the Ospan task is similar in fluid intelligence as individuals that do not reach the 85% threshold, by comparing each group's (i.e., participants that reach or exceed 85% accuracy and those that do not) performance on the RAPM and PMA number series. In addition, the hypothesis is that a majority of individuals that do not meet the 85% threshold of the processing component of the Ospan task are high math anxious, but that these high math anxious individuals do not differ in terms of fluid intelligence. This experiment will use the RAPM and PMA number series to show that individuals that have high levels of math anxiety and/or do not meet the 85% threshold on the processing component of the Ospan do not differ in terms of fluid intelligence.

#### Introduction Conclusion

The two most prominent and frequently used working memory tasks are the Ospan and Rspan tasks. One is a math based task and the other is reading based. The two have been used separately to determine working memory capacity and together to form a working memory capacity factor. However, a theory of math anxiety is that when an individual is faced with or completing a math based task, anxious and intrusive thoughts consume working memory resources that would otherwise be used for task completion. It is possible that a high level of math anxiety causes a decrease in performance and yields a lower and inaccurate working memory capacity score on a math based working memory task. This experiment tests that hypothesis by comparing math anxiety groups' performance on the two most prominent and widely used working memory span tasks. Specifically, individuals with high levels of math anxiety will score lower on the math



portion of the Ospan task than on the Rspan task, which has a reading component in place of the math based component. This decrease in performance will be so low (i.e., less than 85% accuracy) that, according to the current literature (Conway et al., 2005), it would suggest removal of these individuals from further experiment analyses. This would remove half of all high math anxious individuals or up to 15% of the general population from being included in research experiments solely due to their level of math anxiety. This experiment will not only test whether high math anxious individuals are similar to their low math anxious counterparts on the Rspan task, but also on fluid intelligence measures (i.e., RAPM and PMA number series) as well, further supporting a hypothesis that high math anxious individuals do not differ in cognitive matters such as working memory capacity or intelligence, except when facing a math task.

## CHAPTER 2

### METHOD

#### Participants

Participants were drawn from the UNLV department of psychology's subject pool. Of the total 147 participants, there were 57 males (38.8%) that participated in this experiment. Researchers have suggested that math anxiety is widespread across the population with an estimated 17% of the population classified as being high math anxious (Ashcraft, Krause, & Hopko, 2007). The sample collected for this experiment was made up of 41 (27.9%) high, 45 (30.6%) medium, 26 (17.7%) low math anxious individuals, and 35 (23.8%) individuals that were not classified in any of the three math anxiety groups. Individuals were removed from analyses if they scored at or less than chance (50%) on the processing component of either span task. Four individuals performed at or less than chance on the processing component of the Ospan, 2 on the Rspan and 3 for both span tasks. See Table 1 for a full demographic breakdown.

#### Instruments and Procedure

The order of instruments was randomized for each participant using the Latin Square method.

*Demographic questionnaire.* The simple demographic questionnaire consisted of questions about the subject's age, gender, year in school, level of math achievement and experiences with math throughout formal school.

*Operation span (Ospan).* Participants verified whether individual math equations are correct while trying to remember a set of 2, 3, 4, 5 or 6 single syllable nouns (30-120

word frequency in English, based on the Kucera & Francis (1967) word frequency database). Sets sizes were presented randomly for each participant. Participants were shown a math equation and determined whether the equation was correct or incorrect (e.g. “ $(8 / 4) - 2 = 4$ ”) within 5 seconds, which constituted the processing component of the Ospan task. Half of the math equations were correct and half were not. After participants gave their response by typing “y” or “n” they were presented with a single syllable word for 1 second. At that point, the next math equation was presented, followed by another word; this pattern continued until all equations and words were presented for that set size. At the end of a set, participants were instructed to recall and type the words into the computer one at a time in the order they were presented, which constituted the storage component of the Ospan task. Participants were also encouraged to guess if they were not sure about a particular word (i.e., there was no penalty for guessing), but could respond with “dk” (i.e., “don’t know”) if they could not make a guess. There were three trials of each set size (e.g., 2, 3, 4, 5, and 6 sets) for a total possible score of 60.

Processing component accuracy was the overall percentage of correct responses to math equations. Processing component accuracy was also broken down by set size. Based on Friedman and Miyake (2005), storage component performance was calculated as the number of overall correct words recalled in the order they were presented (i.e., strict scoring method). Storage component performance was also analyzed as a percentage of words recalled in each set size due to the greater number of words that are able to be recalled for higher set sizes. Overall percentage of correct math equation responses was calculated, as well as the percent correct for each word set size.

*PMA number series (PMA)*. This task consisted of a series of numbers and required participants to select from a group of possible responses that would continue the series of numbers (Thurstone, 1962). Each of the 15 items required a rule to be discerned in order to select the correct response from five provided options. Following five practice items, participants were told that they have 4.5 minutes to complete 15 test items, which is the standard presentation method. However, participants were allowed to attempt all items even after the 4.5 minutes expired. The PMA number series items were scored in the following ways: 1) overall correct items, 2) overall correct items in 4.5 minutes, 3) number of correct pattern completion items, and 4) number of correct math based items.

*Reading Span (Rspan)*. Participants were required to read individual sentences while trying to remember a set of 2, 3, 4, 5 or 6 single syllable nouns (30-120 word frequency in English, based on the Kucera & Francis (1967) word frequency database) similar to the Ospan. Sets increased in size for all participants. Participants read a sentence and determined whether the sentence made sense (e.g., “The man ate the pizza”) or not (e.g. “The pizza ate the man”) within 5 seconds, which constituted the processing component of the Rspan task. Half of the sentences made sense while the other half did not. After participants gave their response by typing “y” or “n” they were presented with a word for 1 second. At that point, the next sentence was presented, followed by another word; this pattern continued until all sentences and words were presented for that set size. At the end of a set, participants were instructed to recall and type the words into the computer in the order they were presented, which constituted the storage component of the Rspan task. Participants were also encouraged to guess if they were not sure about a particular word (i.e., there was no penalty for guessing), but could respond with “dk” (i.e., “don’t

know”) if they could not make a guess. There were three trials of each set size (i.e., 2, 3, 4, 5, and 6 sets) for a total possible score of 60.

Scoring was done in a similar manner as was done for the Ospan task. Processing component accuracy was the overall percentage of correct responses to sentence queries. Processing component accuracy was also broken down by set size. Based on Friedman and Miyake (2005), storage component performance was calculated as the number of overall correct words recalled in the order they were presented (i.e., strict scoring method). Storage component performance was also analyzed as a percentage of words recalled in each set size due to the greater number of words that are able to be recalled for higher set sizes. Overall percentage of correct math equation responses was calculated, as well as the percent correct for each word set size.

*Raven’s Advanced Progressive Matrices (RAPM, Raven et al., 1998).* The RAPM was used as a measure of abstract reasoning (Raven et al., 1998). The test consisted of 12 practice items followed by 36 test items which increased in difficulty. Each item was made up of a 3 X 3 matrices of geometric patterns with the bottom right pattern missing. A set of 8 options was provided at the bottom of the screen with only one option correctly completing the above pattern. Participants typed their responses into the computer. This task had no time limit, with accuracy and reaction time recorded for each item. A participant’s score was the total number of correct solutions.

*Short Math Anxiety Rating Scale (sMARS, Alexander & Martray, 1989).* The sMARS is a 25 item, 1-5 Likert-type response questionnaire that assessed an individuals’ anxiety about math and math situations. An example item asked a participant to respond how anxious (“1 Not at all” to “5 very much”) they became by “receiving a math text book”.

Scores ranged from 0 to 100 by totaling up the responses to all items (a response of 1 was scored as a 0, a response of 2 was scored as a 1, etc.), with a lower score indicating lower math anxiety.

*Wide Range Achievement Test-3, Arithmetic (WRAT-3)*. The WRAT-3 is an arithmetic test made up of 40 mathematics problems ranging from simple addition to algebra and was used to determine math ability. A participant's score was the total number of problems correct.

## CHAPTER 3

### RESULTS

#### Structure Equation Modeling Results

A structure equation model of the relationship between working memory capacity and fluid intelligence was fit to two samples: all participants and only the participants that meet the span task thresholds. Model fit was acceptable for participants that meet the threshold:  $\chi^2 = .02$ ,  $p < .90$ ,  $CFI = 1.00$  and  $RMSEA = 0.00$ . Each indicator (i.e., RAPM and PMA, and Ospan and Rspan task storage components scores) was significantly related to the respective factors, (i.e., fluid intelligence and working memory capacity). Figure 1 shows that working memory capacity significantly correlated with fluid intelligence,  $r = .50$ , replicating previous findings (Mogle et al., 2008; Unsworth & Spillers, 2010) and indicating that this sample is similar to samples in the published literature. Figure 2 shows the same structural equation model, but including participants that failed to meet the 85% threshold for the Ospan or Rspan. Again, the model fit was acceptable:  $\chi^2 = .69$ ,  $p < .41$ ,  $CFI = 1.00$  and  $RMSEA = 0.00$ . Each indicator significantly related to their respective factors and the working memory latent variable significantly correlated with the fluid intelligence latent variable,  $r = .69$ . This indicates that the relationship between working memory capacity and fluid intelligence did not change with the inclusion of individuals that fail to meet the 85% accuracy threshold. Please see table 2 for the correlation matrix for the relationship between the dependent variables of this experiment (i.e., span task components, fluid intelligence instrument scores, sMARS and WRAT scores).

## Span Task Overall Results

Overall span task analyses (i.e., ANOVA's for processing and storage components) were completed for comparison of this sample to similar samples in the published literature. A repeated measures 2 (Type of span task: Ospan and Rspan) X 5 (Set size: 2, 3, 4, 5, and 6) ANOVA was completed to test for processing component accuracy differences between the two span tasks. The processing component of the Ospan task consisted of math equation verifications and the processing component of the Rspan task consisted of sentence semantics verification. Accuracy on the processing component was the dependent variable, and the two span tasks (i.e., Ospan and Rspan) and all 5 set sizes were treated as within-subjects variables. See Table 3 for set size processing component accuracy of the two span tasks.

A significant main effect was found for type of span task, with a higher accuracy associated with the processing component of the Rspan task ( $M = .930$ ,  $SE = .005$ ) than the Ospan task ( $M = .891$ ,  $SE = .007$ ),  $F(1, 146) = 30.240$ ,  $MSE = .019$ ,  $p < .0005$ ,  $\eta_p^2 = .172$ , possibly indicating a higher level of difficulty of the processing component of the Ospan task. A second main effect was found for set size on processing performance,  $F(4, 584) = 10.436$ ,  $MSE = .007$ ,  $p < .0005$ ,  $\eta_p^2 = .067$ . Using Bonferroni's  $t$  statistic (used for all post hoc testing), post hoc tests revealed that set size 2 was significantly higher than set size 6,  $p < .0005$ ; set size 3 was significantly higher than set size 5, and 6,  $p < .05$  and  $p < .0005$ , respectively; set size 4 was significantly higher than set size 6,  $p < .001$ ; set size 5 was significantly higher than set size 6,  $p < .005$ . As the items of the processing task increased in difficulty, the decrease in mean scores across set size indicate a competition



for working memory resources from the increase in words to be recalled. The interaction between type of span task and set size was not significant,  $F = .657, p = .622$ .

A second repeated measures 2 (Type of span task: Ospan and Rspan) X 5 (Set size: 2, 3, 4, 5, and 6) ANOVA was completed to test for storage component performance differences between the two span tasks. Percentage of words correctly recalled in the order they were presented was the dependent variable, and the two span tasks (i.e., Ospan and Rspan) and all 5 set sizes were treated as within-subjects variables. See Table 3 for set size storage component performance of the two span tasks.

A significant main effect was found for type of span task, with a higher percentage of words correctly recalled in the order they were presented for the Ospan task ( $M = .786, SE = .011$ ) than the Rspan task ( $M = .699, SE = .012$ ),  $F(1, 146) = 108.364, MSE = .026, p < .0005, \eta_p^2 = .426$ . Similar words for recall were used in the storage component of both span tasks, so this difference could be explained by a difference in difficulty of the processing component of the task or proactive interference within the Rspan task. A second main effect was found for set size on storage performance,  $F(4, 584) = 316.814, MSE = .024, p < .0005, \eta_p^2 = .685$ . Post hoc tests revealed that a significantly higher percentage of words was correctly recalled in the order they were presented for each set size compared to the next higher set size,  $p < .0005$ . This main effect is intuitive: difficulty increased as set size increased due to the increase in words required for recall.

A significant two-way interaction was found between set size and type of span task on storage performance,  $F(4, 584) = 12.258, MSE = .016, p < .0005, \eta_p^2 = .077$ . The differences in percentage of words correctly recalled decreased at a higher rate for the Rspan task compared to word recall on the Ospan task. Post hoc tests revealed that word

recall on each set of the Ospan task was higher than the same Rspan task set size, except for set 2  $p < .05$ . See Figure 3 for the interaction of set size and type of span task on word recall. Again, this interaction may be due to either an increased level of difficulty in the processing component of the Ospan task or proactive interference in the Rspan task.

### Span Task Processing Component Performance and Math Anxiety

Hypothesis 1: Individuals with high math anxiety will score statistically significantly lower on the processing (i.e., math based) component of the Ospan task than the processing (i.e., reading based) component of the Rspan task.

Math anxiety groups are a subset of the total number of participants of this experiment and their results replicate many of the previous overall span task results. The three math anxiety groups are made up of 112 of the total 147 participants, with the difference being the 35 participants that did not fit in the math anxiety group parameters. Please see tables 4, 5, and 6 for the correlation matrix for the relationship between the dependent variables of this experiment (i.e., span task components, fluid intelligence instrument scores, sMARS and WRAT scores) for each math anxiety group (i.e., low, medium, and high).

Separate one-way ANOVAs were completed for the three math anxiety group's (i.e., low, medium and high) performance on the processing component of the Rspan and the Ospan. A significant difference was found between the low ( $M = .92$ ,  $SE = .013$ ), medium ( $M = .91$ ,  $SE = .009$ ) and high ( $M = .86$ ,  $SE = .102$ ) math anxiety groups on the processing component of the Ospan task,  $F(2,111) = 4.806$ ,  $p = .010$ . Post hoc tests revealed that high math anxious individuals and medium math anxious individuals scored

significantly lower than low math anxious individuals,  $p=.018$  and  $p=.050$ . A significant difference was not found between the low ( $M = .94$ ,  $SE = .011$ ), medium ( $M = .93$ ,  $SE = .009$ ) and high ( $M = .92$ ,  $SE = .010$ ) math anxiety groups on the processing component of the Rspan task,  $F(2,111) = 1.690$ ,  $p=.189$ . See Table 7 for math anxiety groups' span task processing component performance and Table 8 for processing component performance by set size.

### Math Anxiety Effects due to Math Ability

Hypothesis 2: Math anxiety groups will not score significantly differently on the processing component of the Ospan task when controlling for math ability.

A mixed model 3 (Math anxiety groups: low, medium, and high) X 2 (Type of span task: Ospan and Rspan) ANCOVA was completed, controlling for math ability (i.e., WRAT-3 performance), to test for math ability effects on processing component performance of the two span tasks. Accuracy on the processing component was the dependent variable. Math anxiety group was treated as a between-subjects variable and the two span tasks (i.e., Ospan and Rspan) were treated as within-subjects variable and WRAT-3 performance was a covariate.

A significant main effect was found for type of span task, with Ospan processing component accuracy ( $M = .893$ ,  $SE = .007$ ) being lower than Rspan processing component accuracy ( $M = .930$ ,  $SE = .006$ ),  $F(1, 108) = 10.465$ ,  $MSE = .004$ ,  $p<.005$ ,  $\eta_p^2 = .088$ , similar to the above overall and math anxiety span task results. An interaction between type of span task and math anxiety group membership was not found,  $F = .357$ . Post hoc tests showed that low ( $M = .899$ ,  $SE = .015$ ), medium ( $M = .901$ ,  $SE = .011$ ) and

high ( $M = .880$ ,  $SE = .012$ ) math anxious individuals no longer performed significantly differently on the Ospan processing component when controlling for math ability,  $p > .5$  or greater.

#### Span Task Storage Component Performance and Math Anxiety

Hypothesis 4: Math anxiety groups will not perform differently on the storage component of the two working memory span tasks.

A mixed model 3 (Math anxiety group: low, medium, and high) X 2 (Type of span task: Ospan and Rspan) ANOVA was completed to test for math anxiety effects on overall storage performance. The total number of words correctly recalled was the dependent variable. Math anxiety group was a between-subjects variable and the two span tasks (i.e., Ospan and Rspan) were within-subjects variables. See Table 7 for math anxiety groups' span task overall storage component performance and Table 9 for storage component performance by set size.

A significant main effect for type of span task was found, with more words recalled on the Ospan task ( $M = 45.255$ ,  $SE = .866$ ) than the Rspan task ( $M = 39.287$ ,  $SE = .959$ ),  $F(1, 109) = 86.592$ ,  $MSE = 21.760$ ,  $p < .0005$ ,  $\eta_p^2 = .443$ . A significant difference was not found in overall word recall by math anxiety groups on the two span tasks combined,  $F = 2.477$ ,  $p = .089$ , or individually on the Ospan task or Rspan task,  $p > .10$  for all groups. However, post hoc tests revealed that all three math anxiety groups recalled more words on the Ospan task than the Rspan task,  $p < .0005$ . The three math anxiety groups' span task storage component performance is found in Table 7.

Finally, the interaction between type of span task and math anxiety group on storage performance was not significant,  $F = .015, p = .985$ .

To further explore whether there were any differences between the anxiety groups for the storage component, a mixed model 3 (Math anxiety group: low, medium, and high) X 2 (Type of span task: Ospan and Rspan) X 5 (2, 3, 4, 5, and 6 Set size) ANOVA was completed. The percentage of words correctly recalled for each set was the dependent variable. Math anxiety group was a between-subjects variable, the two span tasks (i.e., Ospan and Rspan) and set sizes (i.e., set size 2, 3, 4, 5, and 6) were within-subjects variables.

A main effect was not found for math anxiety group membership on storage component performance on the two span tasks,  $F = 2.226, p = .113$ , and post hoc testing revealed no differences between the groups,  $p > .05$ . Post hoc tests revealed that all three math anxiety groups recalled a higher percentage of words on the Ospan task (Low:  $M = .803, SE = .027$ , Medium:  $M = .821, SE = .021$ , High:  $M = .759, SE = .022$ ) than the Rspan task (Low:  $M = .722, SE = .030$ , Medium:  $M = .736, SE = .023$ , High:  $M = .677, SE = .024$ ),  $p < .0005$ .

A significant main effect was found for type of span task, with Ospan task storage component performance ( $M = .794, SE = .013$ ) being higher than Rspan task storage component performance ( $M = .712, SE = .015$ ),  $F(1, 109) = 62.121, MSE = .029$ ,  $p < .0005, \eta_p^2 = .363$ .

A significant main effect was again found for set size on storage performance (Set 2:  $M = .918, SE = .011$ , set 3:  $M = .865, SE = .015$ , set 4:  $M = .785, SE = .017$ , set 5:  $M = .664, SE = .019$ , and set 6:  $M = .535, SE = .018$ ),  $F(4, 436) = 228.354, MSE = .022$ ,

$p < .0005$ ,  $\eta_p^2 = .677$ . Post hoc tests revealed that performance significantly decreased for each set size,  $p < .001$ .

A significant two-way interaction was found between set size and type of span task in storage performance,  $F(4, 436) = 10.009$ ,  $p < .0005$ ,  $\eta_p^2 = .084$ . Word recall on the Rspan task declined at a greater rate as set size increased compared to word recall on the Ospan task. Post hoc tests revealed that word recall on all set sizes except set size 1 of the Ospan task was higher than the Rspan task,  $p < .01$  or less. Word recall performance for both span tasks significantly decreased as set size increased,  $p < .005$  or less, except for set size 2 and 3 of the Ospan task.

Significant interactions were not found between type of span task and math anxiety group,  $F = .014$ ,  $p = .986$ , set size and math anxiety group,  $F = 1.808$ ,  $p = .074$ , or type of span task and set size and math anxiety group on storage performance,  $F = 1.035$ ,  $p = .408$ .

### Span Task Threshold Results

A primary question of this paper was whether math anxiety may be a cause for poor performance on the math based Ospan task processing component. Specifically, math anxiety may negatively influence performance on the processing component of the Ospan task to such a degree that high math anxious individuals fail to reach the inclusion criterion of 85% accuracy and subsequently are removed from experimental analyses. The current literature (summarized by Conway et al., 2005) suggests that individuals that fail to reach the 85% accuracy threshold of the processing component of the Ospan task lack motivation. Of the total 147 participants, 37 (25.2%) failed to meet the 85%

accuracy threshold of the processing aspect of the Ospan task. To differentiate between possible math anxiety effects and a possible lack of motivation on span task performance, three “threshold” groups were formed: (1) participants that met the 85% accuracy threshold on the processing component of the Ospan task or the “met threshold” group, (2) low and medium math anxious individuals that failed to meet the 85% accuracy threshold on the processing component of the Ospan task or the “low anxiety-failed threshold” group, and (3) high math anxious individuals that failed to meet the 85% accuracy threshold on the processing component of the Ospan task or the “high anxiety-failed threshold” group. These three groups allowed for testing whether math anxiety influenced performance on the math based processing component of the Ospan task. Comparisons can be made between high anxiety-failed threshold group and low anxiety – failed threshold group, and between high anxiety – failed threshold group and met threshold group. For example, if math anxiety is a cause of poor performance on the Ospan task processing component, high math anxious individuals that failed to meet the threshold would perform at a higher level compared to all other participants that failed to meet the threshold at other non-math based tasks (e.g., storage component, Rspan task processing component, RAPM, and PMA). The probable cause of high math anxiety individuals’ poor performance on the Ospan processing component would not be present for non-math based instruments, whereas the lack of motivation that is the probable cause of others’ poor performance would remain for other tasks. In addition, these same high anxiety – failed threshold individuals would perform at similar levels as the met threshold individuals.

Of the 147 total participants in this experiment, 37 (25.2%) and 15 (10.2%) failed to reach the 85% accuracy threshold on the processing components of the Ospan and Rspan tasks, respectively. Of those, 7 failed both tasks with 4 being high math anxious (out of 41 total high math anxious individuals). See Table 8 for a breakdown of threshold groups' span tasks processing component and storage component performances.

Hypothesis 3: Individuals with high math anxiety will make up a majority of individuals that do not meet the 85% threshold of the processing component of the Ospan task.

As shown in Table 1, there were 13 high anxiety – failed threshold individuals, which is greater than the 11 low anxiety – failed threshold individuals. The 13 high anxiety – failed threshold individuals constituted 54.2% of the participants that fit into the three math anxiety groups that failed to meet the accuracy threshold.

A mixed model 3 (Threshold groups: met threshold, low anxiety - failed threshold, and high anxiety – failed threshold) X 2 (Type of span task: Ospan and Rspan) ANOVA was completed to test for processing component accuracy differences between the individuals that met and failed to meet the 85% accuracy threshold of the processing component of the Ospan task. Accuracy on the processing component was the dependent variable. The between-subjects variable was threshold group membership, which had three levels: met threshold, low anxiety – failed threshold, or high anxiety – failed threshold. Type of span task (i.e., Ospan and Rspan) was treated as within-subjects variables. Threshold group performance on the processing component of each span task is found in Table 9.

A significant main effect was found for the three threshold groups, with the met threshold group ( $M = .931$ ,  $SE = .004$ ) scoring higher on the two span tasks than the low



anxiety – failed threshold group ( $M = .853$ ,  $SE = .013$ ) and the high anxiety – failed threshold group ( $M = .822$ ,  $SE = .012$ ),  $F(2, 109) = 50.066$ ,  $MSE = .004$ ,  $p < .0005$ ,  $\eta_p^2 = .479$ . Post hoc tests revealed that all three groups performed significantly differently,  $p < .0005$ .

Replicating the overall span results and math anxiety groups results, a significant main effect was found for the two span tasks, with processing component accuracy higher on the Rspan task ( $M = .917$ ,  $SE = .008$ ) than the Ospan task ( $M = .820$ ,  $SE = .007$ ),  $F(1, 109) = 97.567$ ,  $MSE = .002$ ,  $p < .0005$ ,  $\eta_p^2 = .472$ .

A significant two-way interaction was found between the met threshold group, low anxiety – failed threshold group and high anxiety – failed threshold group, and type of span task,  $F(2, 109) = 37.501$ ,  $p < .0005$ ,  $\eta_p^2 = .408$ ). This interaction is primarily due to the two failed threshold groups scoring higher on the Rspan task than the Ospan task,  $p < .0005$ . Post hoc tests revealed that the met threshold group scored significantly higher on the Ospan task processing component than both failed threshold groups,  $p < .0005$ . This difference between the three threshold groups is a given and is due to the method used to create the groups (i.e., the groups were divided using the participants Ospan task processing component performance and the arbitrary 85% accuracy threshold). In addition, the low anxiety – failed threshold group scored significantly higher on the processing component of the Ospan task than the high anxiety – failed threshold group,  $p < .05$ . The three threshold groups did not perform significantly differently on the processing component of the Rspan task,  $p > .05$ . This result indicates that while these groups perform differently on the processing component of the Ospan task, they do not perform differently on the processing component of the Rspan task. See Figure 4 for the

interaction between the threshold groups' processing component performance on the two span tasks.

A mixed model 3 (Threshold groups: met threshold, low anxiety – failed threshold, and high anxiety – failed threshold) X 2 (Type of span task: Ospan and Rspan) ANOVA was completed to test for storage component differences between the individuals that met and failed to meet the 85% accuracy threshold of the processing component of the Ospan task. Storage component performance on the two span tasks was the dependent variable. The between-subjects variable was threshold group membership, which had three levels: met threshold, low anxiety – failed threshold, and high anxiety – failed threshold. Type of span task (i.e., Ospan and Rspan) was treated as within-subjects variables.

A significant main effect was found between the three threshold groups, as the met threshold group recalled more words on the two span tasks ( $M = 43.972$ ,  $SE = .881$ ) than low anxiety – failed threshold group ( $M = 33.227$ ,  $SE = 2.492$ ) and high anxiety – failed threshold group ( $M = 38.115$ ,  $SE = 2.293$ ),  $F(2, 109) = 136.650$ ,  $MSE = 10.088$ ,  $p < .0005$ ,  $\eta_p^2 = .156$ . Post hoc tests revealed that the met threshold group recalled more words on both span tasks than the low anxiety – failed threshold group,  $p < .0005$ , but not significantly more than high anxiety – failed threshold group,  $p > .05$ . The lack of difference between the met threshold group and the high anxiety – failed threshold group directly supports a primary claim of this paper: that high math anxious individuals, even those that fail to meet the Ospan processing component threshold, have a similar working memory capacity as individuals that do meet the threshold. A second main effect was found for type of span task, with more words correctly recalled in the storage component of the Ospan task ( $M = 41.317$ ,  $SE = 1.177$ ) than the Rspan task ( $M = 35.559$ ,  $SE =$

1.329),  $F(1, 109) = 38.452$ ,  $MSE = 21.647$ ,  $p < .0005$ ,  $\eta_p^2 = .261$ . A Significant interaction was found between type of span task and threshold group,  $F(2, 109) = 37.501$ ,  $MSE = .002$ ,  $p < .0005$ ,  $\eta_p^2 = .408$ . Please see Figure 4 and Table 9 for the threshold groups' storage component performance on the two span tasks. Post hoc tests revealed that the met threshold group correctly recalled more words on the Ospan task than either the low anxiety – failed threshold group or the high anxiety – failed threshold group,  $p < .0005$  and  $p < .05$  respectively. However, the met threshold group correctly recalled more words on the Rspan task than only the low anxiety – failed threshold group,  $p < .001$ .

#### Fluid Intelligence Measures and Math Anxiety

Hypothesis 5: Math anxiety groups will not perform differently on the RAPM.

Hypothesis 6: Individuals with high math anxiety will score statistically significantly lower on the PMA number series than medium or low math anxious individuals.

Separate one-way ANOVAs were completed for the three math anxiety groups and the two most prominently used fluid intelligence measures in the recent working memory literature, the RAPM and PMA, and the Wide Range Arithmetic Test-3 (WRAT-3). The three math anxiety groups did not perform significantly differently on the full RAPM,  $F = .867$ ,  $p = .423$ , odd items,  $F = .782$ ,  $p = .460$ , or even items,  $F = .967$ ,  $p = .384$ . The three math anxiety groups did not perform differently on the PMA with a 4.5 minute time limit,  $F = 1.862$ ,  $p = .160$ , or untimed,  $F = 1.488$ ,  $p = .230$ . Unsurprisingly, the three math anxiety groups performed differently on the WRAT-3,  $F(2, 109) = 9.448$ ,  $p < .0005$ . High math anxious individuals ( $M = 27.49$ ,  $SE = 1.059$ ) scored significantly lower than

either low math anxious ( $M = 33.23$ ,  $SE = .855$ ) or medium math anxious individuals ( $M = 30.73$ ,  $SE = .665$ ),  $p < .0005$  and  $p < .05$  respectively.

Separate one-way ANOVAs were completed for the three threshold groups (e.g., Individuals that met the threshold, low and medium math anxious individuals that failed to meet the threshold and high math anxious individuals that failed to meet the 85% accuracy threshold on the processing component of the Ospan) and the same two fluid intelligence measures from above, the RAPM and the PMA number series, and the WRAT-3. On the subset of even items of the RAPM, which is frequently used in the working memory literature as a substitute for the full RAPM, the met threshold group ( $M = 9.61$ ,  $SE = .336$ ) scored marginally significantly higher than the low anxiety – failed threshold group ( $M = 7.27$ ,  $SE = .604$ ),  $p = .053$ . The met threshold group did not differ from the high anxiety – failed threshold group,  $p = .452$ . Mirroring differences in performance on the RAPM, the met threshold group ( $M = 8.73$ ,  $SE = .223$ ) scored significantly higher on the PMA only compared to the low anxiety – failed threshold group ( $M = 6.73$ ,  $SE = .333$ ),  $p < .01$ . Differences in WRAT-3 performance were due to the high anxiety – failed threshold group ( $M = 22.92$ ,  $SE = .2.165$ ) scoring lower than either the met threshold group ( $M = 31.41$ ,  $SE = .515$ ) or the low anxiety – failed threshold group ( $M = 28.36$ ,  $SE = .1.064$ ),  $p < .0005$  and  $p < .05$  respectively.

## CHAPTER 4

### DISCUSSION

Working memory is historically, and to this day remains, a central construct of cognitive psychology. An individual's working memory capacity was originally measured using simple recall tasks, called simple span tasks, that determined the number of separate items that an individual could store and recall. Later, as research on the nature of working memory has grown, more complicated measures have been created. The construct of working memory and an individual's working memory capacity has been found to relate to a host of behaviors and activities, such as reading comprehension (Daneman & Carpenter, 1980) and performance on academic (Engle, et al., 1999) and intelligence (Conway et al., 2002) tests.

The Ospan and Rspan tasks are the most frequently and widely used instruments that measure a person's working memory capacity. The two span tasks are used interchangeably throughout the field of psychology. Researchers (Conway et al., 2005) suggest that the current working memory span tasks, such as the Ospan, are not domain specific, but actually tap into domain general executive attention and control. Working memory capacity does not fluctuate due to task characteristics.

Spurred by Baddeley and Hitch's (1974) suggestion that a true measure of working memory is more than just a recall task and that simple span tasks were not sufficient to measure working memory, Daneman and Carpenter (1980) created the Rspan task. The reading span task is made up of two components: a processing and a storage component. Researchers (Turner & Engle, 1989; Conway et al., 2005) use a person's storage component score as the participant's actual working memory capacity and suggest that

the processing component is just a secondary task that inhibits or interferes with the use of strategies such as rehearsal to improve storage performance. In fact, Engle (e.g., Turner & Engle, 1989) implicitly acknowledges the processing component's role in determining a person's working memory capacity by applying a performance threshold as an exclusion criterion. Turner and Engle (1989) applied a threshold of 80% accuracy on the processing component of the operation span task, a counterpart to Daneman and Carpenter's (1980) reading span task, for a person's inclusion in an experiment. Failing to meet this threshold was suggested to be due to a lack of motivation on the part of the participant. The processing component accuracy threshold was subsequently raised to its current level of 85% (as reported by Conway et al., 2005).

Aside from a loose measure of motivation, performance on the processing component was viewed with an additional concern. Daneman and Carpenter (1980) hypothesized that individuals with high reading ability may complete the processing component of the reading span (i.e., reading sentences) more quickly and allow for alternative cognitive strategies that would not be available to individuals with low reading ability. This concern, that greater abilities associated with the nature of the processing task could influence overall span task performance, was also raised by Turner and Engle (1989) for both the reading span and operation span processing component. However, Daneman and Carpenter (1980) failed to measure processing task performance and Turner and Engle (1989) failed to report their sample's performance on the processing component.

Some of the current experiment's results support the theory that individuals that fail to reach the 85% accuracy threshold of the processing component of either span task are different than those that do meet or exceed the threshold. Two of the most prominent

examples would be the significant differences in the Ospan task processing component performance (a given) and more importantly the differences in Ospan task storage component performance. The met threshold group was able to recall significantly more words in the storage component compared to those that failed to meet the threshold.

However, many of this experiment's results do not support the use of the arbitrary 85% accuracy threshold of the Ospan task processing component. This is especially evident in the improvement in processing component performance from the Ospan task to the Rspan task. Individuals that failed to meet the 85% threshold on the Ospan task performed significantly lower than individuals that met the threshold, but only on the Ospan task. These groups did not perform differently on the processing component of the Rspan task. If a general lack of motivation is the reason for failure to meet the threshold, why would a person be motivated to complete one span task, the Rspan, but not the other, the Ospan?

This is the central question of this experiment: are there differences between the processing components of the two span tasks that could potentially hinder performance? Specifically, why would an individual perform better on the processing component of the Rspan task than the Ospan task? Or asked differently, why would an individual fail to meet the 85% accuracy threshold on the processing component of the Ospan task, but not the Rspan task? There is wide spread acknowledgement that some participants in research experiments lack motivation. But, they lack motivation only on one task, specifically, on the math based processing component of the Ospan task?

There may be an alternative explanation for the poor performance on the Ospan task processing component beside a general lack of motivation, one concerning the math

aspect of the processing component of the Ospan task: individuals perform much worse on the processing component of the Ospan task compared to the Rspan task due to math anxiety. In fact, a greater number of high math anxious individuals (13) failed to reach the Ospan task processing component 85% accuracy threshold than both low and medium math anxious individuals combined (11). This indicates that a primary reason for failure to meet the accuracy threshold is due to math anxiety, especially when the performance of these individuals improves so dramatically on the processing component of the Rspan task.

Hypothesis 1, which stated that high math anxiety individuals would score lower than other math anxiety groups on the processing component of the Ospan task, was supported by high math anxious individuals scoring lower than medium and low math anxious individuals on the Ospan task processing component. In contrast, the three math anxiety groups did not perform differently on the Rspan task processing component. This indicates that math anxiety has a significant influence on performance on the math based Ospan task. The math anxiety effect appears to be so great that high math anxious individuals, as a group, barely perform above the 85% threshold on the Ospan task, unlike their quite normal performance on the Rspan task.

Hypothesis 2 predicted that math anxiety groups would not score significantly differently on the processing component of the Ospan task when controlling for math ability and was supported. This hypothesis supports the long term avoidance theory of math anxiety effects on math tasks. Long-term avoidance theory suggests that individuals with high math anxiety are poor at math due to a lifelong avoidance of math situations such as academic arithmetic classes. Performance on the WRAT-3 reflects



acquisition of math skills through schooling and life experience with lower scores possibly indicating avoidance of math learning situations. Low math anxious individuals scored significantly higher than high math anxious individuals on the math based processing component of the Ospan task, but when math ability (i.e., WRAT-3) performance was covaried out, the difference was no longer significant, supporting hypothesis 2. This change indicates that a portion of the difference between the math anxiety groups is due to math ability.

What are the implications of math anxiety's influence on Ospan task performance? Experimenters using the Ospan task to determine their participants' working memory capacity (of which there are many) may be biasing their sample and removing many participants from experimental analyses that they should not. As an example, a hypothetical researcher is studying cognitive variable X and believes that working memory capacity plays a role in variable X. The researcher determines that 100 participants are needed to study the effects of working memory capacity on variable X. If 20 participants fail to reach the Ospan task processing component accuracy threshold of 85%, the results of this experiment suggest that at least 10 of those participants have failed due to math anxiety. This hypothetical researcher using this working memory measure would be increasing data collection efforts by 10 to 20%. This may not sound like much, but 10% of each researcher's sample, experiment after experiment, year after year adds up to a large number of participants that would have been included in an experiment, if not for their high level of math anxiety.

A second possible implication of math anxiety's effects on Ospan performance is that a researcher's data may be skewed. For example, a second hypothetical researcher is

studying the relationship between working memory capacity and decision-making involving an arithmetic task. The researcher predicts that individuals with high working memory capacity would select a math based strategy to respond to coin tossing questions. In testing this hypothesis the researcher uses the Ospan task to determine participants working memory capacity. However, using the 85% threshold for inclusion in the experiment an inordinate number of high math anxious individuals would be removed. These individuals are less likely to use a math based strategy to complete the coin tossing task, instead preferring to use a heuristic. The researcher's results would not reflect the accurate number of individuals that would have used a strategy other than a math based one and would lead to an incorrect conclusion.

According to nearly all working memory researchers, storage component performance, not processing component performance, is the actual indicator of working memory capacity. Hypothesis 4 predicted that math anxiety groups would not perform differently on the storage component of either of the two working memory span tasks. Results supported hypothesis 4 by math anxiety groups not recalling a significantly different number of words in the span task storage components. This indicates that high, medium and low math anxious individuals, despite differences in Ospan task processing component performance, did not have differences in working memory capacity.

Results indicated that math anxiety played a significant role in the Ospan task processing component performance, which led to subsequent testing of its role in the failure to meet the Ospan processing component 85% accuracy threshold and the formation of three "threshold" groups: (1) participants that met the 85% accuracy threshold on the processing component of the Ospan task or the "met threshold" group,

(2) low and medium math anxious individuals that failed to meet the 85% accuracy threshold on the processing component of the Ospan task or the “low anxiety-failed threshold” group, and (3) high math anxious individuals that failed to meet the 85% accuracy threshold on the processing component of the Ospan task or the “high anxiety-failed threshold” group. The threshold groups allowed for an investigation into possible differences between individuals that failed to meet the threshold. Specifically, math anxiety appears to have such a detrimental effect on the Ospan task processing component performance that even among the members of the math anxiety groups that failed to meet the threshold, high math anxious individuals perform lower than medium and low math anxious individuals. However, the three threshold groups, met threshold group, low anxiety – failed threshold group and high anxiety – failed threshold group, did not perform differently on the Rspan task processing component. The high anxiety – failed threshold group was also able to recall as many words in the Rspan task storage component as the met threshold group, indicating their similar levels of the working memory capacity.

To further explore math anxiety’s effects on the performance of both the Ospan and Rspan tasks, and that the 85% threshold for processing component performance may be an inappropriate criterion, participants completed two widely used fluid intelligence measures in the current working memory literature, the RAPM and PMA number series. Fluid intelligence is thought to be a domain general cognitive ability that aids in completing novel tasks. Working memory researchers (Conway et al., 2002; Mogle et al., 2008; Unsworth & Engle, 2006) have found that working memory capacity and fluid intelligence are positively related. Hypothesis 6 predicted a difference in performance on

the PMA number series by math anxiety groups, but was not supported by the results. This prediction was based on the fact that the PMA number series task was math based and would therefore generate math anxiety effects on performance. However, it appears that the PMA number series task does not invoke a level of math anxiety that interferes with task performance, possibly due to the fact that some of the trials of the PMA number series do not call for even a single arithmetic operation to be performed. However, RAPM results supported hypothesis 5 and indicated that high math anxious individuals do not differ from other math anxiety groups and specifically that the high anxiety – failed threshold group was not different than the met threshold group in terms of fluid intelligence. PMA number series results matched RAPM results: the high anxiety – failed threshold group did not differ from the met threshold group. These two fluid intelligence measures' results further support a claim that high math anxious individuals should not be excluded from an experiment, and the 85% Ospan processing component threshold may not be an appropriate exclusion criterion.

APPENDIX 1

TABLES AND FIGURES

Table 1  
Summary of Demographic Variables.

Demographic Variable	Math Anxiety Groups			Significance
	Low (n = 26)	Med. (n = 45)	High (n = 41)	
Gender (M/F)	12/14	16/29	12/29	
Age	21.42	19.39	21.98	
Class Year	1.88	1.73	1.90	
Number of H.S. math courses taken	4.04	3.84	3.83	
H.S. math grade	3.15	3.09	2.62	<i>p</i> <.05
Number of college math courses	1.73	1.52	1.00	
College math grade	2.64	2.23	1.86	
Rated math anxiety	3.04	5.23	5.85	<i>p</i> <.0005
Rated math enjoyment	6.88	5.09	3.53	<i>p</i> <.0005
sMARS score	10.27	36.22	60.34	<i>p</i> <.0005
	n (%)	n (%)	n (%)	
Failed to reach 85% Ospan Proc.	4 (15.4)	7 (15.6)	13 (31.7)	
Failed to reach 85% Rspan Proc.	2 (7.7)	5 (11.1)	4 (9.8)	
Ethnic Group				
African-American	2 (7.7)	4 (8.9)	4 (10.0)	
Hispanic/Latino	2 (7.7)	5 (11.1)	9 (22.5)	
Asian/Pacific Islander	3 (11.5)	15 (33.3)	14 (35.0)	
Caucasian	18 (69.2)	20 (44.4)	13 (32.5)	
Other	1 (3.8)	1 (2.2)		

Table 2  
Overall Correlation matrix ( $n=147$ )

---

	RAPM	RAPM even	WRAT	sMARS	PMA NS	Ospan Proc	Ospan storage	Rspan Proc	Rspan storage
RAPM	--	.930	.273	-.123	.265	.236	.359	.136	.256
RAPM even		--	.227	-.059	.256	.204	.361	.138	.269
WRAT			--	-.354	.363	.437	.290	.276	.258
sMARS				--	-.123	-.160	-.117	-.102	-.073
PMA NS					--	.383	.335	.165	.299
Ospan process						--	.470	.288	.380
Ospan storage							--	.216	.757
Rspan process								--	.329
Rspan storage									--

---

Note: all correlation coefficients greater than .164,  $p < .05$  or less

Table 3  
 Processing and Storage Component Performance of each Span Task by Set Size.  $M (SE)$ .

		Set Size $M (SE)$				
		2	3	4	5	6
Processing Component	Ospan	.897 (.015)	.923 (.011)	.897 (.010)	.894 (.010)	.882 (.010)
	Rspan	.952 (.009)	.941 (.008)	.936 (.009)	.931 (.009)	.914 (.008)
Storage Component	Ospan	.926 (.014)	.890 (.017)	.826 (.019)	.715 (.020)	.614 (.019)
	Rspan	.910 (.014)	.841 (.018)	.739 (.020)	.613 (.023)	.455 (.020)

Table 4  
 Correlation matrix of low math anxiety group ( $n=26$ )

	RAPM	RAPM even	WRAT	sMARS	PMA NS	Ospan Proc	Ospan storage	Rspan Proc	Rspan storage
RAPM	--	.945	.384	.113	.345	.308	.506	.031	.472
RAPM even		--	.309	.176	.320	.290	.477	.069	.473
WRAT			--	-.038	.338	.573	.460	.199	.425
sMARS				--	.136	.217	.352	.493	.289
PMA NS					--	.363	.362	-.137	.398
Ospan process						--	.735	.367	.567
Ospan storage							--	.363	.775
Rspan process								--	.462
Rspan storage									--

Note: all correlation coefficients greater than .385,  $p < .05$  or less



Table 5  
 Correlation matrix of medium math anxiety group ( $n=45$ )

	RAPM	RAPM even	WRAT	sMARS	PMA NS	Ospan Proc	Ospan storage	Rspan Proc	Rspan storage
RAPM	--	.907	.233	-.019	.413	.302	.365	.239	.241
RAPM even		--	.189	-.029	.387	.241	.345	.270	.208
WRAT			--	.023	.451	.405	.316	.348	.231
sMARS				--	-.162	-.180	.143	.091	.140
PMA NS					--	.589	.406	.246	.301
Ospan process						--	.498	.249	.394
Ospan storage							--	.215	.797
Rspan process								--	.284
Rspan storage									--

Note: all correlation coefficients greater than .300,  $p < .05$  or less

Table 6  
Correlation matrix of high math anxiety group ( $n=41$ )

	RAPM	RAPM even	WRAT	sMARS	PMA NS	Ospan Proc	Ospan storage	Rspan Proc	Rspan storage
RAPM	--	.925	.270	-.236	.090	.111	.251	-.031	.072
RAPM even		--	.288	-.146	.082	.149	.287	.034	.128
WRAT			--	-.125	.293	.422	.213	.185	.223
sMARS				--	.012	.225	-.223	.063	-.100
PMA NS					--	.233	.323	-.110	.065
Ospan process						--	.189	.183	.065
Ospan storage							--	.101	.693
Rspan process								--	.232
Rspan storage									--

Note: all correlation coefficients greater than .312,  $p < .05$  or less

Table 7  
 Math Anxiety Groups' Span Task Performance. *M (SE)*.

Math Anxiety Group	Processing Accuracy			Storage Performance		
	Ospan	Rspan	sig	Ospan	Rspan	sig
Low (n=26)	.920 (.016)	.945 (.012)	n.s.	45.885 (1.747)	40.077 (1.935)	<i>p</i> <.0005
Medium (n=45)	.905 (.012)	.931 (.009)	n.s.	46.978 (1.328)	40.978 (1.471)	<i>p</i> <.0005
High (n=41)	.863 (.013)	.917 (.009)	<i>p</i> <.0005	42.902 (1.391)	36.805 (1.541)	<i>p</i> <.0005
Overall (n=112)	.896 (.008)	.931 (.006)	<i>p</i> <.0005	45.255 (.866)	39.287 (.959)	<i>p</i> <.0005

Table 8  
 Processing Component Accuracy of each Span Task by Math Anxiety Group by Set Size.  
*M (SE).*

Set Size	Ospan			Rspan		
	Math Anxiety Groups			Math Anxiety Groups		
	Low	Medium	High	Low	Medium	High
2	.922 (.030)	.911 (.022)	.857 (.024)	.968 (.019)	.936 (.015)	.951 (.015)
3	.958 (.023)	.919 (.017)	.892 (.018)	.937 (.016)	.949 (.013)	.938 (.013)
4	.917 (.020)	.904 (.015)	.870 (.016)	.940 (.019)	.936 (.014)	.934 (.015)
5	.910 (.021)	.912 (.016)	.859 (.016)	.948 (.018)	.936 (.014)	.910 (.015)
6	.909 (.020)	.890 (.016)	.848 (.016)	.941 (.015)	.913 (.012)	.889 (.012)

Table 9  
 Storage Component Performance of each Span Task by Math Anxiety Group by Set Size.  
*M (SE).*

Set Size	Ospan			Rspan		
	Math Anxiety Groups			Math Anxiety Groups		
	Low	Medium	High	Low	Medium	High
2	.942 (.027)	.952 (.021)	.885 (.022)	.916 (.027)	.929 (.021)	.886 (.022)
3	.880 (.034)	.907 (.026)	.882 (.027)	.830 (.037)	.828 (.028)	.866 (.030)
4	.843 (.038)	.837 (.029)	.799 (.030)	.747 (.039)	.786 (.030)	.685 (.031)
5	.718 (.039)	.749 (.030)	.677 (.031)	.649 (.047)	.644 (.035)	.545 (.037)
6	.633 (.039)	.658 (.030)	.552 (.031)	.467 (.040)	.493 (.031)	.405 (.032)

Table 10  
 Threshold Groups' Span Task Performance. *M (SE)*

Ospan 85% Accuracy Threshold	Processing Accuracy			Storage Performance		
	Ospan	Rspan	sig	Ospan	Rspan	sig
Met (n=88)	.928 (.005)	.935 (.006)	n.s.	47.034 (.889)	40.909 (1.004)	<i>p</i> <.0005
Low/Medium Failed (n=11)	.793 (.015)	.914 (.018)	<i>p</i> <.0005	36.455 (2.516)	30.000 (2.839)	<i>p</i> <.001
High Failed (n=13)	.741 (.013)	.903 (.017)	<i>p</i> <.0005	40.462 (2.314)	35.769 (2.612)	<i>p</i> <.05

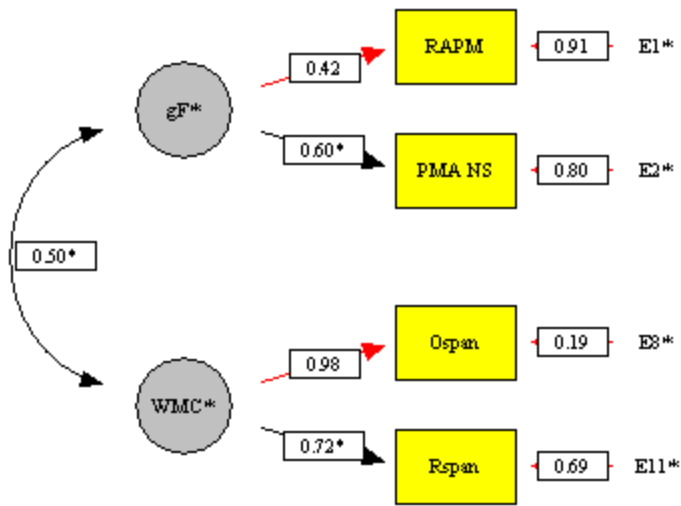

Fig. 1. Structural equation model of relationship between working memory capacity and fluid intelligence with participants that met Ospan and Rspan thresholds ( $n=102$ ).

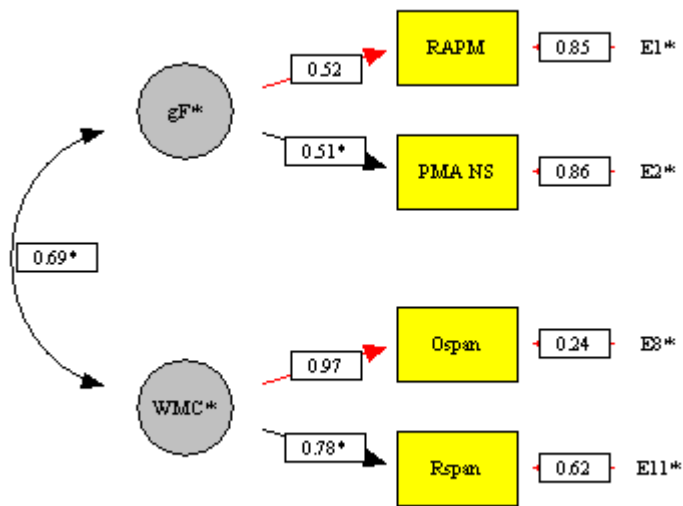

Fig. 2. Structural equation model of relationship between working memory capacity and fluid intelligence with all participants included ( $n=147$ ).



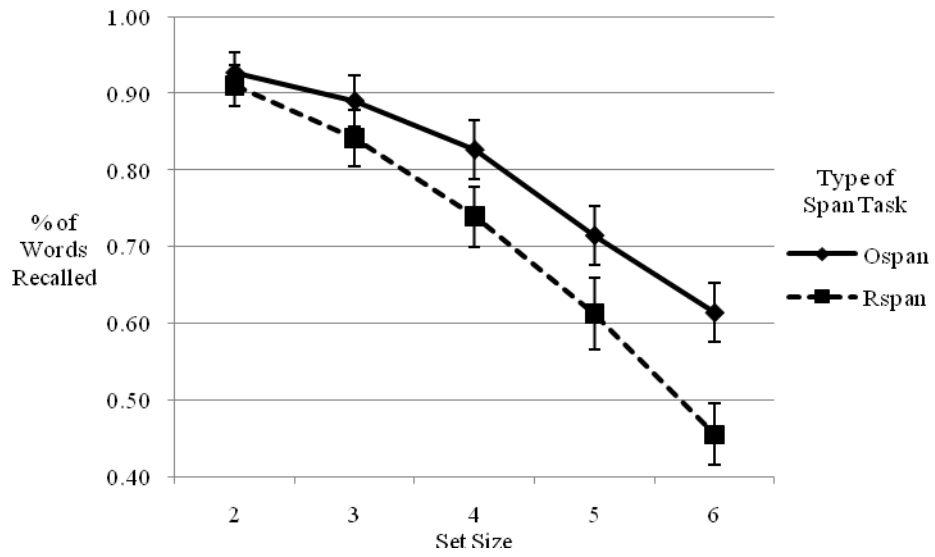

Fig. 3. Set Size Word Recall % on the Storage Component of the Two Span Tasks.

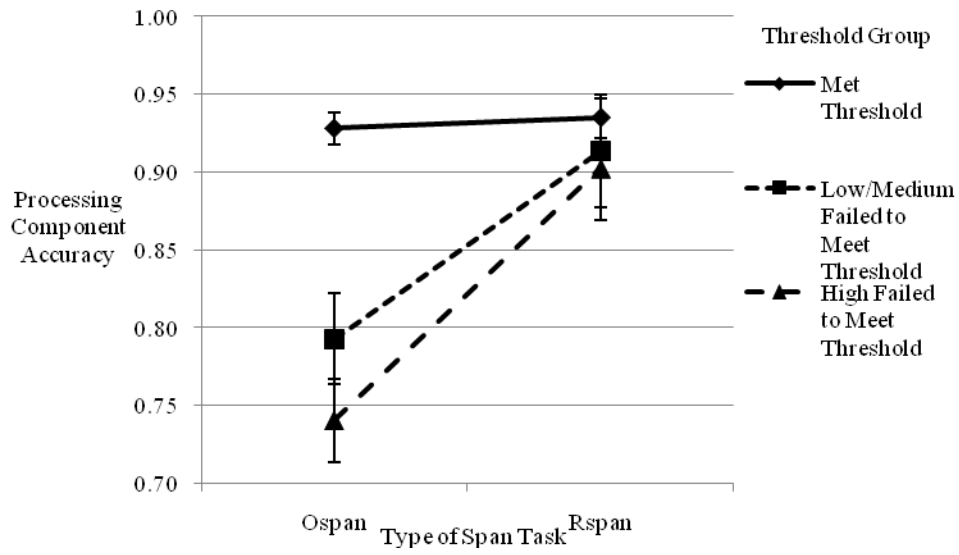
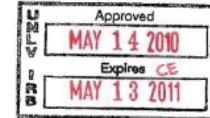

Fig. 4. Processing Component Accuracy by the Three Threshold Groups on the Two Span Tasks.

## APPENDIX 2

### OPRS APPROVAL



### Social/Behavioral IRB – Expedited Review Approval Notice

#### NOTICE TO ALL RESEARCHERS:

*Please be aware that a protocol violation (e.g., failure to submit a modification for any change) of an IRB approved protocol may result in mandatory remedial education, additional audits, re-consenting subjects, researcher probation suspension of any research protocol at issue, suspension of additional existing research protocols, invalidation of all research conducted under the research protocol at issue, and further appropriate consequences as determined by the IRB and the Institutional Officer.*

**DATE:** May 14, 2010  
**TO:** Dr. Mark Ashcraft, Psychology  
**FROM:** Office of Research Integrity - Human Subjects  
**RE:** Notification of IRB Action by Dr. Charles Rasmussen, Co-Chair *CR/CE*  
Protocol Title: **Pattern Recognition: Linear Number Sequences and Raven's Matrices**  
Protocol #: 1004-3447

---

This memorandum is notification that the project referenced above has been reviewed by the UNLV Social/Behavioral Institutional Review Board (IRB) as indicated in Federal regulatory statutes 45 CFR 46. The protocol has been reviewed and approved.

The protocol is approved for a period of one year from the date of IRB approval. The expiration date of this protocol is May 13, 2011. Work on the project may begin as soon as you receive written notification from the Office of Research Integrity - Human Subjects (ORI Human Subjects).

#### PLEASE NOTE:

Attached to this approval notice is the **official Informed Consent/Assent (IC/A) Form** for this study. The IC/A contains an official approval stamp. Only copies of this official IC/A form may be used when obtaining consent. Please keep the original for your records.

Should there be *any* change to the protocol, it will be necessary to submit a **Modification Form** through ORI Human Subjects. No changes may be made to the existing protocol until modifications have been approved by the IRB.

Should the use of human subjects described in this protocol continue beyond May 13, 2011, it would be necessary to submit a **Continuing Review Request Form** 60 days before the expiration date.

If you have questions or require any assistance, please contact the Office of Research Integrity - Human Subjects at [IRB@unlv.edu](mailto:IRB@unlv.edu) or call 895-2794.

Office of Research Integrity - Human Subjects  
4505 Maryland Parkway • Box 451047 • Las Vegas, Nevada 89154-1047

## BIBLIOGRAPHY

- Ackerman, P. L., Beier, M. E., & Boyle, M. O. (2002). Individual differences in working memory within a nomological network of cognitive and perceptual speed abilities. *Journal of Experimental Psychology: General*, *131*, 567–589.
- Alderton, D. L., & Larson, G. E. (1990). Dimensionality of Raven's Advanced Progressive Matrices items. *Educational and Psychological Measurement*, *50*, 887-900.
- Anastasi, A. (1988). *Psychological testing*. New York, NY, England: Macmillan Publishing.
- Arthur, W., & Woehr, D. J. (1993). A confirmatory factor analytic study examining the dimensionality of the Raven's Advanced Progressive Matrices. *Educational and Psychological Measurement*, *53*, 471-478.
- Ashcraft, M. H. (1982). The development of mental arithmetic: A chronometric approach. *Developmental Review*, *2*, 213-236.
- Ashcraft, M. H. (1985). Is it farfetched that some of us remember our arithmetic facts? *Journal of Research in Mathematics Education*, *16*, 99-105.
- Ashcraft, M. H. (1995). Cognitive psychology and simple arithmetic: A review and summary of new directions. *Mathematical Cognition*, *1*, 3-34.
- Ashcraft, M. H., & Battaglia, J. (1978). Cognitive arithmetic: Evidence for retrieval and decision processes in mental addition. *Journal of Experimental Psychology: Human Learning & Memory*, *4*, 527-538.
- Ashcraft, M. H., & Fierman, B. A. (1982). Mental addition in third, fourth, and sixth graders *Journal of Experimental Child Psychology*, *33*, 216-234.

- Ashcraft, M. H., & Kirk, E. P. (1998). *The relationships among working memory, math anxiety, math competence, and attitudes toward math*. Unpublished manuscript.
- Ashcraft, M. H., & Kirk, E. P. (2001). The relationships among working memory, math anxiety, and performance. *Journal of Experimental Psychology: General*, *130*, 224-237.
- Ashcraft, M. H., Kirk, E. P. Hopko, D. (1998). On the cognitive consequences of mathematics anxiety, The development of mathematical skills, Donlan (Ed.) Hove, England: Psychology Press, 1998, 175-196.
- Ashcraft M. H., & Moore, A. M. (2009). Mathematics anxiety and the affective drop in performance. *Journal of Psychoeducational Assessment*, *27*(3), 197-205.
- Ashcraft, M. H., & Stazyk, E. H. (1981). Mental addition: A test of three verification models. *Memory & Cognition*, *9*, 185-196.
- Baddeley, A. D. (1966). Short-term memory for word sequences as a function of acoustic, semantic and formal similarity. *The Quarterly Journal of Experimental Psychology*, *18*, 362-365.
- Baddeley, A. D. (1986). *Working memory*. Oxford, England: Oxford University Press.
- Baddeley, A. D. (1992). Is working memory working? The Fifteenth Bartlett lecture. *Quarterly Journal of Experimental Psychology*, *44A*, 1-31.
- Baddeley, A. D. (2000). The episodic buffer: A new component of working memory? *Trends in Cognitive Science*, *11*, 417-423.
- Baddeley, A. D. (2003) Working memory: Looking back and looking forward. *Nature Reviews Neuroscience*, *4*, 829-839.

- Baddeley, A. D., & Hitch, G. J. (1974). Working memory. In G. H. Bower (Ed.), *The psychology of learning and motivation* (Vol. 8, pp. 47-89). New York: Academic Press.
- Baddeley, A.D., Thomson, N., & Buchanan, M. (1975). Word length and the structure of short-term memory. *Journal of Verbal Learning & Verbal Behavior*, *14*, 575-589.
- Baroody, A. J., (1983). The development of procedural knowledge: An alternative explanation for chronometric trends of mental arithmetic. *Developmental Review*, *3*, 225-230.
- Beilock, S. L., Gunderson, E. A., Ramirez, G., & Levine, S. C. (2010). Female teachers' math anxiety affects girls' math achievement. *Proceedings of the National Academy of Sciences of the United States of America*, *107*(5), 1860-1863.
- Brand, C. (1987). Bryter still and bryter? *Nature*, *328*, 110.
- Campbell, J. I. D. (1987). Production, verification, and priming of multiplication facts. *Memory & Cognition*, *15*, 349-364.
- Campbell, J. I. D. (1995). Mechanisms of simple addition and multiplication: A modified network-interference theory and simulation. *Mathematical Cognition*, *1*, 121-164.
- Campbell, J. I. D., & Graham, D. J. (1985). Mental multiplication skill: Structure, process and acquisition. *Canadian Journal of Psychology*, *39*, 338-366.
- Campbell, J. I. D., & Xue, Q. (2001). Cognitive arithmetic across cultures. *Journal of Experimental Psychology: General*, *130*, 299- 315.
- Carpenter, P. A., Just, M. A., and Shell, P. (1990). What one intelligence test measures: A theoretical account of the processing in the Raven Progressive Matrices test. *Psychological Review*, *97*, 404-431.

- Cattell, R. B. (1963). Theory of fluid and crystallized intelligence: A critical experiment. *Journal of Educational Psychology, 54*, 1-22.
- Cattell, R. B. (1971). *Abilities: their structure, growth, and action*. Oxford, England: Houghton Mifflin.
- Colle, H. A., & Welsh, A. (1976). Acoustic masking in primary memory. *Journal of Verbal Learning & Verbal Behavior, 15*, 17-31.
- Colom, R., Escorial, S., & Rebollo, I. (2004). Sex differences on the progressive matrices are influenced by sex differences on spatial ability. *Personality and Individual Differences, 37*, 1289-1293.
- Colom, R., Rebollo, I., Palacios, A., Juan-Espinosa, M., & Kyllonen, P. (2004). Working memory is (almost) perfectly predicted by g. *Intelligence, 32*, 277-296.
- Conrad, R. & Hull, A. J. (1964). Information, acoustic confusion, and memory span. *British Journal of Psychology, 55*, 429-432.
- Conway, A. R. A., Cowan, N., Bunting, M. F., Theriault, D. J., & Minkoff, S. R. B. (2002). A latent variable analysis of working memory capacity, short-term memory capacity, processing speed, and general fluid intelligence. *Intelligence, 30*, 163–183.
- Cowan, N. (2001). The magical number 4 in short-term memory: A reconsideration of mental storage capacity. *Behavioral and Brain Sciences, 24*, 97–185.
- Court, J. H. (1983). Sex differences in performance on Raven's progressive matrices: A review. *Alberta Journal of Educational Research, 29*, 54–74.
- De Rammelaere, S., Stuyven, E., & Vandierendonck, A. (1999). The contribution of working memory resources in the verification of simple mental arithmetic sums. *Psychological Research, 62*, 72-77.

- De Rammelaere, S., Stuyven, E., and Vandierendonck, A. (2001). Verifying simple arithmetic sums and products : Are the phonological loop and the central executive involved? *Memory & Cognition*, *29*, 267-273.
- De Rammelaere, S., & Vandierendonck, A. (2001). Are executive processes used to solve simple arithmetic production tasks. *Current Psychology Letters: Behaviour, Brain and Cognition*, *5*, 79-90.
- DeShon, R. P., Chan, D., & Weissbein, D. A. (1995). Verbal overshadowing effects on Raven's Advanced Progressive Matrices: Evidence for multidimensional performance determinants. *Intelligence*, *21*, 135–155.
- Dillon, R. F., Pohlman, J. T., & Lohman, D. F. (1981). A factor analysis of Raven's Advanced Progressive Matrices freed of difficulty factors. *Educational and Psychological Measurement*, *41*, 1295-1302.
- Engle, R. W., Tuholski, S. W., Laughlin, J. E., & Conway, A. R. A. (1999). Working memory, short-term memory and general fluid intelligence. A latent-variable approach. *Journal of Experimental Psychology: General*, *128*, 309–331.
- Faust, M. W., Ashcraft, M. H., & Fleck, D. E. (1996). Mathematics anxiety effects in simple and complex addition. *Mathematical Cognition*, *2(1)*, 25-62.
- Friborg, O., Barlaug, D., Martinussen, M., Rosenvinge, J. H., & Hjemdal, O. (2005). Resilience in relation to personality and intelligence. *International Journal of Methods in Psychiatric Research*, *14*, 29-42.
- Foulds G. A., and Raven, J. C. (1950). An experimental survey with progressive matrices (1947). *British Journal of Educational Psychology*, *20*, 104-110.



- Forbes, A. R. (1964). An item analysis of the advanced matrices. *British Journal of Educational Psychology*, 34, 1-14.
- Fürst, A. J., and Hitch, G. J. (2000). Separate roles for executive and phonological components of working memory in mental arithmetic. *Memory & Cognition*, 28, 774-782.
- Gardner, M. K. (1983). Some remaining puzzles concerning analogical reasoning and human abilities. *Dissertation Abstracts International*, 43, 4177.
- Geary, D. C., Brown S. C., & Samaranajake, V. A. (1991). Cognitive addition: A short longitudinal study of strategy choice and speed-of-processing differences in normal and mathematically disabled children. *Developmental Psychology*, 27, 787-797.
- Gottfredson, L. S. (1997). Why g matters: The complexity of everyday life. *Intelligence*, 24, 79-132.
- Groen, G. J., & Parkman, J. M. (1972). A chronometric analysis of simple addition. *Psychological Review*, 79, 329-343.
- Hamann, M. S., & Ashcraft, M. H. (1986). Textbook presentations of the basic addition facts. *Cognition & Instruction*, 3, 173-192.
- Heathcote, D. (1994). The role of visuo-spatial working memory in the mental addition of multi-digit addends. *Current Psychology of Cognition*, 13, 207-245.
- Hecht, S. (2002). Counting on working memory in simple arithmetic when counting is used for problem solving. *Memory & Cognition*. 30, 447-455.
- Holzman, T. G., Glaser, R., & Pellegrino, J. W. (1980, April). Cognitive determinants of series completion: Individual and developmental differences. *Paper presented at the meeting of the American Educational Research Association*, Boston, MA.

- Holzman, T. G., Pellegrino, J. W., & Glaser, R. (1982). Cognitive dimensions of numerical rule induction. *Journal of Educational Psychology, 74*, 360-373.
- Holzman, T. G., Pellegrino, J. W., & Glaser, R. (1983). Cognitive variables in series completion. *Journal of Educational Psychology, 75*, 603-618.
- Hopko, D. R., Ashcraft, M. H., Gute, J., Ruggiero, K. J., & Lewis, C. (1998). Mathematics anxiety and working memory: support for the existence of a deficient inhibition mechanism. *Journal of Anxiety Disorders, 4*, 343-355.
- Irwing, P., & Lynn, R. (2005). Sex differences in means and variability on the progressive matrices in university students: A meta-analysis. *British Journal of Psychology, 96*, 505-524.
- Jacobs, P. I. (1966). Programmed progressive matrices. *Proceedings of the 74th Annual Convention of the American Psychological Association, 2*, 263-264. (Abstract)
- Jacobs, P. I., & Vandeventer, M. (1968). Progressive Matrices: An experimental, developmental, non-factorial analysis. *Perceptual and Motor Skills, 27*, 759-766.
- Jacobs, P. I., & Vandeventer, M. (1972). Evaluating the teaching of intelligence. *Educational and Psychological Measurement, 32*, 235-248.
- Jensen, A. (1980). *Bias in mental testing*. London: Methuen.
- Jensen, A. R. (1987). Psychometric g as a focus of concerted research effort. *Intelligence, 11*, 193-198.
- Jensen, A. R. (1998). *The g Factor*. Westport, CT: Praeger.
- Jensen, A. R., & Reynolds, C. R. (1983). Sex differences on the WISC-R. *Personality and Individual Differences, 4*, 223-226. 1984

- Kane, M. J., Hambrick, D. Z., Tuholski, S. W., Wilhelm, O., Payne, T. W., & Engle, R. W. (2004). The generality of working-memory capacity: A latent-variable approach to verbal and visuo-spatial memory span and reasoning. *Journal of Experimental Psychology: General*, *133*, 189–217.
- Kellog, J., Hopko, D. R., & Ashcraft, M. H. (1999). The effects of time pressure on arithmetic performance, *Journal of Anxiety Disorders*, *13*(6), 591-600.
- Kyllonen, P. C., & Christal, R. E. (1990). Reasoning ability is (little more than) working-memory capacity? *Intelligence*, *14*, 389–433.
- Kotovsky, K., & Simon, H. A. (1973). Empirical tests of a theory of human acquisition of concepts for sequential patterns. *Cognitive Psychology*, *4*, 399-424.
- Kucera and Francis, W.N. (1967). *Computational Analysis of Present-Day American English*. Providence: Brown University Press.
- Kuncel, N., R., Hezlett, S. A., and Ones, D. S. (2004). Academic performance, career potential, creativity, and job performance: Can one construct predict them all? *Journal of Personality and Social Psychology*, *86*, 148-161.
- Lee, K., & Kang, S. (2002). Arithmetic operation and working memory: differential suppression in dual tasks. *Cognition*, *83*, 63-68.
- Lefevre, J., & Lui, J. (1997). The role of experience in numerical skill: Multiplication performance in adults from Canada and China. *Mathematical Cognition*, *3*, 31-62.
- LeFevre, J. A., Sadesky, G. S., & Bisanz, J. (1996). Selection of procedures in mental addition: Reassessing the problem-size effect in adults. *Journal of Experimental Psychology: Learning, Memory, & Cognition*, *22*, 216-230.

- LeFevre, J. A., Shanahan, T., & Destefano, D. (1996). The tie effect in simple arithmetic: An access-based account. *Memory & Cognition*, 32, 1019-1031.
- Lemaire, P., Abdi, H., & Fayol, M. (1996). The role of working memory resources in simple cognitive arithmetic. *European Journal of Cognitive Psychology*, 8, 73-103.
- Logie, R.H., Gilhooly, K. J., & Wynn, V. (1994). Counting on working memory in arithmetic problem solving. *Memory & Cognition*, 22, 395-410.
- Lubinski, D., Webb, R. M., Morelock, M. J. & Benbow, C. P. (2001). Top 1 in 10,000: a 10-year follow-up of the profoundly gifted. *Journal of Applied Psychology*, 84, 718-729.
- Lynn,R. (1998). Sex differences in intelligence: a rejoinder to Mackintosh. *Journal of Biosocial Science*, 30, 529–532.
- Lynn, R. (2002). Sex differences on the Progressive Matrices among 15–16 year olds: Some data from South Africa. *Personality and Individual Differences*, 33, 669–677.
- Lynn, R., & Chan, P. W. (2002). Sex differences on the Progressive Matrices: Some data from Hong Kong. *Journal of BiosocialScience*, 34, 145–154.
- Lynn, R., & Irwing, P. (2004). Sex differences on the advanced progressive matrices in college students. *Personality and Individual Differences*, 37, 219-223.
- Mackintosh, N. J. (1996). Sex differences and IQ. *Journal of Biosocial*, 28, 559–572.
- Mackintosh, N. J., & Bennett, E. S. (2005). What do Raven’s Matrices measure? An analysis in terms of sex differences. *Intelligence*, 33, 663-674.
- Miller, G. A. (1956). The magical number seven, plus or minus two: Some limits on our capacity for processing information. *PsychologicalReview*.63. 81-97.

- Miller, K., Perlmutter, M., & Keating, D. (1984). Cognitive arithmetic: Comparison of operations. *Journal of Experimental Psychology: Learning, Memory, and Cognition*, *10*, 1984.
- Miyake, A., & Shah, P. (1999). *Models of working memory: mechanisms of active maintenance and executive control*. New York: Cambridge University Press.
- Mogle, J. A., Lovett, B. J., Stawski, R. S., & Sliwinski, M. J. (2008). What's so special about working memory? An examination of the relationship among working memory, secondary memory, and fluid intelligence. *Psychological Science*, *19*, 1071–1077.
- Parkman, J. H. (1972). Temporal aspects of simple multiplication and comparison. *Journal of Experimental Psychology*, *95*, 437-444.
- Parkman, J. H., and Groen, G. J. (1971). Temporal aspects of simple addition and comparison. *Journal of Experimental Psychology*, *89*, 335-342.
- Paul, S. M. (1985). The advanced Raven's Progressive Matrices: normative data for an American university population and examination of the relationship with Spearman's *g*. *Journal of Experimental Education*, *54*, 95–100.
- Ree, M. J., & Caretta, T. R. (1998). In top-down decisions, weighting variables does not matter: A consequence of Wilks' theorem. *Organizational Research Methods*, *14*, 1998.
- Raven, J. C. (1939). The RECI series of perceptual tests: An experimental survey. *British Journal of Medical Psychology*, *18*, 16–34.
- Raven, J. C. (1947). *Advanced Progressive Matrices*. London: Lewis.
- Raven, J. C. (1947). *Coloured Progressive Matrices (Sets I, II and III)*. London: Lewis.

- Raven, J. C. (1962). *Advanced Progressive Matrices* (Sets I and II). London: Lewis.
- Raven, J. C., Raven, J. E., & Court, J. H. (1998). *Progressive Matrices*. Oxford, England: Oxford Psychologists Press.
- Salame, P. and Baddeley, A. D. (1982). Disruption of short-term memory by unattended speech: Implications for the structure of working memory. *Journal of Verbal Learning & Verbal Behavior*, 21, 150-164.
- Schmidt, F. L. (2002). The role of general cognitive ability and job performance: Why there cannot be a debate. *Human Performance*, 15, 187-211.
- Seitz, K., and Schumann-Hengsteler, R. (2002). Phonological loop and central executive processes in mental addition and multiplication. *Psychologische Beiträge, Special Issue: Working memory*, 44, 275-302.
- Shah, P. & Miyake, A. (1997). The separability of working memory resources for spatial thinking and language processing: An individual differences approach. *Journal of Experimental Psychology*, 125, 4-27.
- Simon, H. A., and Kotovsky, K. (1963). Human acquisition of concepts for sequential patterns. *Psychological Review*, 70, 534-546.
- Spearman, C. (1904). 'General intelligence', objectively determined and measured. *The American Journal of Psychology*, 15, 201-293.
- Spearman, C. (1927). *The abilities of man*. New York: Macmillan.
- Spearman, C. (1946). Theory of general factor. *British Journal of Psychology*, 36, 117-131.

- Stazyk, E.H., Ashcraft, M.H., & Hamann, M. S. (1982). A network approach to mental multiplication. *Journal of Experimental Psychology: Learning, Memory, & Cognition*, 8, 320-335.
- Suss, H., Oberauer, K., Wittman, W. W., Wilhelm, O., & Schulze, R. (2002). Working-memory capacity explains reasoning ability—and a little bit more. *Intelligence*, 30, 261-288.
- Svenson, O. (1984). Cognitive processes in judging cumulative risk over different periods of time. *Organizational Behavior & Human Performance*, 33, 22-41.
- Thorndike, R. L., and Hagen, E. (1971). *Cognitive Abilities Test*. Boston: Houghton Mifflin.
- Thurstone, T. G. (1962). *Primary Mental Abilities*. Chicago: Science Research Associates.
- Trbovich, P. L. and Lefevre, J. (2003). Phonological and visual working memory in mental addition. *Memory & Cognition*, 31, 738-745.
- Unsworth, N. (2010a). On the division of working memory and long-term memory and their relation to intelligence: A latent variable approach. *Acta Psychologica*, 134, 16-28.
- Unsworth, N. (2010b). Interference control, working memory capacity, and cognitive abilities: A latent variable analysis. *Intelligence*, 38, 255-267.
- Unsworth, N., & Engle, R. W. (2006). Simple and complex memory spans and their relation to fluid abilities: Evidence from list-length effects. *Journal of Memory and Language*, 54, 68–80.

- Unsworth, N., Heitz, R. P., Schrock, J. C., & Engle, R. W. (2005). An automated version of the operation span task. *Behavior Research Methods*, *37*, 498–505.
- Unsworth, N., & Spillers, G. (2010). Working memory capacity: Attention control, secondary memory, or both? A direct test of the dual-component model. *Journal of Memory and Language*, *62*, 392-406.
- Vallar, G., & Shallice, T. (1990). *Neuropsychological impairments of short-term memory*. New York, NY, US: Cambridge University Press.
- Verguts, T., & De Boeck, P. (2002). On the correlation between working memory capacity and performance on intelligence tests. *Learning and Individual Differences*, *13*, 37-55.
- Vernon, P. E. and Parry, J. B. (1949). *Personnel selection in the British forces*. London, England: University of London Press.
- Wilkinson, G. S. (1993). *Manual for the Wide Range Achievement Test* (3rd ed.). Wilmington, DE: Wide Range.
- Yates, A. J. (1961). Item analysis of progressive matrices: 1947. *British Journal of Educational Psychology*, *31*, 152-157.



## VITA

Graduate College  
University of Nevada, Las Vegas

Robert Thomas Durette

### Degrees:

Bachelor of Arts, Psychology, 2006

University of Nevada, Las Vegas, Las Vegas, Nevada

Master of Arts, Psychology, 2009

University of Nevada, Las Vegas, Las Vegas, Nevada

### Publications:

**Durette, R.** Gray, P., & Marrs, C. (Manuscript accepted on 18 June 2010). *Fathers faring poorly: Results of an internet-based survey of fathers of young children.* American Journal of Men's Health

Marrs, C., **Durette, R.**, Ferraro, D., & Cross, C. (2009). Dimensions of postpartum psychiatric distress: Preliminary evidence for broadening clinical scope. *Journal of Affective Disorders, 115*, 100-111.

Dissertation Title: Operation Span Task's Susceptibility to Math Anxiety:  
Support from Fluid Intelligence

### Dissertation Examination Committee:

Chairperson, Mark H. Ashcraft, Ph.D.

Committee Member, David E. Copeland, Ph.D.

Committee Member, Joel S. Snyder, Ph.D.

Graduate Faculty Representative, Gabriele Wulf, Ph.D.