

2009

## Health motivation in health behavior: Its theory and application

Xiaoyan Xu

University of Nevada Las Vegas

Follow this and additional works at: <https://digitalscholarship.unlv.edu/thesesdissertations>



Part of the [Social Psychology Commons](#)

---

### Repository Citation

Xu, Xiaoyan, "Health motivation in health behavior: Its theory and application" (2009). *UNLV Theses, Dissertations, Professional Papers, and Capstones*. 42.

<https://digitalscholarship.unlv.edu/thesesdissertations/42>

This Dissertation is protected by copyright and/or related rights. It has been brought to you by Digital Scholarship@UNLV with permission from the rights-holder(s). You are free to use this Dissertation in any way that is permitted by the copyright and related rights legislation that applies to your use. For other uses you need to obtain permission from the rights-holder(s) directly, unless additional rights are indicated by a Creative Commons license in the record and/or on the work itself.

This Dissertation has been accepted for inclusion in UNLV Theses, Dissertations, Professional Papers, and Capstones by an authorized administrator of Digital Scholarship@UNLV. For more information, please contact [digitalscholarship@unlv.edu](mailto:digitalscholarship@unlv.edu).

HEALTH MOTIVATION IN HEALTH BEHAVIOR: ITS THEORY AND  
APPLICATION

by

Xiaoyan Xu

Bachelor of Science  
Chongqing Normal University (China)  
1999

Master of Arts  
Southwest University (China)  
2003

Master of Arts  
University of New Hampshire  
2006

A dissertation submitted in partial fulfillment  
of the requirements for the

**Doctor of Philosophy in Psychology**  
**Department of Psychology**  
**College of Liberal Arts**

**Graduate College**  
**University of Nevada, Las Vegas**  
**August 2009**

Copyright by Xiaoyan Xu 2009  
All Rights Reserved

## ABSTRACT

### **Health Motivation in Health Behavior: Its Theory and Application**

by

Xiaoyan Xu

Dr. Murray G. Millar, Examination Committee Chair  
Associate Professor of Psychology  
University of Nevada, Las Vegas

The present research proposed a definition and a theoretical model of health motivation that consists of four stages: development of health motivation tendency, formation of health intention, initiation of health related action, and persistence in actions to achieve goals developed at the first stage. Based upon this model, two health motivation scales – the Health Motivation Scale in Physical Activities (HMS-PA) and Health Motivation Scale in Healthy Eating (HMS-HE) were developed. Two studies were conducted to validate the validity of the scores obtained by these two scales. Study 1 proposed a definition and a theoretical model of health motivation, as well as two scales – HMS-PA and HMS-HE. By examining 251 UNLV undergraduate participants, the construct validity of the scores of these two scales was tested using exploratory factor analysis respectively. Three different models for each of the two scales were determined. Their scores' discriminant validity was tested by correlating them with Health Self Determinism Index (HSDI) and Self-Motivation Inventory (SMI) respectively as well. The correlations of the scores of these scales were close to zero, indicating that these two scales were different from the HSDI and SMI. Study 2 examined and compared the three models of each scale. It was found that HMS-PA model 2 was the best among the three

and HMS-HE model 3 was the best among its three models. Study 2 also investigated the predictive power of health motivation by comparing it with several other variables – health value, health self-efficacy, and BMI. The findings showed that health motivation was a powerful predictor of health behaviors, especially among females. For males, health self-efficacy was a stronger predictor of their health behaviors than health motivation. In conclusion, the proposed theoretical model of health motivation and the two health motivation scales are effective to capture individuals' health motivation. This model and the scales can be applied to related theoretical and empirical studies.

## TABLE OF CONTENTS

ABSTRACT.....	iii
LIST OF TABLES.....	vii
LIST OF FIGURES.....	ix
ACKNOWLEDGMENTS.....	x
CHAPTER 1 INTRODUCTION.....	1
CHAPTER 2 MOTIVATION.....	3
Theories of Motivation.....	3
Measures of Motivation.....	6
Health Motivation.....	8
CHAPTER 3 A BRIEF REVIEW ON HEALTH MOTIVATION.....	10
Theories of Health Behavior that Include Health Motivation.....	10
Empirical Studies Involving Health Motivation.....	23
Measures of Health Motivation and Health Behaviors.....	27
Limitations in Previous Research and Purposes of the Present Study.....	31
CHAPTER 4 STUDY 1.....	32
A Proposed Theoretical Model of Health Motivation.....	32
Health Motivation Scales in Physical Activities and Healthy Eating.....	34
Methods.....	35
Results.....	38
CHAPTER 5 STUDY 2.....	69
Purposes.....	69
Methods.....	69
Results.....	76
CHAPTER 6 CONCLUSION AND DISCUSSION.....	146
The Construct Validity of the Scores Obtained by the Two Health Motivation Scales.....	146
Discriminant Validity.....	148
Predictive Validity.....	148
The Process Model of Health Motivation.....	150
Health Motivation, Health Self-efficacy, Health Value, and BMI.....	151
Gender Effects.....	152
Conclusion.....	153

APPENDIX I THE TWO HEALTH MOTIVATION SCALES.....	155
APPENDIX II ADOLESCENT FOOD HABITS CHECKLIST.....	159
APPENDIX III THE TWO OTHER MOTIVATION SCALES.....	160
APPENDIX IV ROKEACH'S HEALTH VALUE SURVEY.....	164
APPENDIX V HEALTH SELF-EFFICACY SCALE.....	165
APPENDIX VI IRB APPROVALS.....	166
BIBLIOGRAPHY.....	170
VITA.....	183

## LIST OF TABLES

Table 1 Comparison among the Models.....	24
Table 2 The 95 <sup>th</sup> Percentile of the Random Eigenvalues and Eigenvalues from the Original Data (for HMS-PA Model 1).....	41
Table 3 Pattern Coefficients (PC) and Structure Coefficients (SC) Obtained from Principal Axis Factoring Solution with Oblimin Rotation (N=259) for the HMS-PA Model 1.....	43
Table 4 Pattern Coefficients (PC) and Structure Coefficients (SC) Obtained from Principal Axis Factoring Solution with Oblimin Rotation (N=259) for the HMS-PA Model 1.....	44
Table 5 The 95 <sup>th</sup> Percentile of the Random Eigenvalues and Eigenvalues from the Original Data (for the HMS-PA Model 2).....	46
Table 6 Pattern Matrix Obtained from Principal Axis Factoring Solution (N = 259) Sorted by Size of Factor Loadings for the HMS-PA Model 3.....	47
Table 7 The 95 <sup>th</sup> Percentile of the Random Eigenvalues and Eigenvalues from the Original Data (for the HMS-PA Model 3).....	50
Table 8 The 95 <sup>th</sup> Percentile of the Random Eigenvalues and Eigenvalues from the Original Data (for the HMS-HE Model 1).....	56
Table 9 Pattern Coefficients (PC) and Structure Coefficients (SC) Obtained from Maximum Likelihood Solution with Oblimin Rotation (N = 259) for the HMS-HE Model 1.....	57
Table 10 Pattern Coefficients (PC) and Structure Coefficients (SC) Obtained from Maximum Likelihood Solution with Oblimin Rotation (N = 259) for the HMS-HE Model 2.....	59
Table 11 The 95 <sup>th</sup> Percentile of the Random Eigenvalues and Eigenvalues from the Original Data (for the HMS-HE Model 2).....	61
Table 12 Pattern Matrix Obtained from Maximum Likelihood Solution (N = 259) Sorted by Size of Factor Loadings for the HMS-HE Model 3.....	62
Table 13 The 95 <sup>th</sup> Percentile of the Random Eigenvalues and Eigenvalues from the Original Data (for the HMS-HE Model 3).....	63
Table 14 Correlations between the First-order Factors in the HMS-PA Model 1.....	77
Table 15 Correlations between the First-order Factors in the HMS-PA Model 2.....	83
Table 16 Correlations between the First-order Factors in the HMS-PA Model 3.....	85
Table 17 Correlations between the First-order Factors in the HMS-HE Model 1.....	93
Table 18 Correlations between the First-order Factors in the HMS-HE Model 2.....	98
Table 19 Correlations between the First-order Factors in the HMS-HE Model 3.....	102
Table 20 Multiple Regression when the HMS-PA Model 1 Included.....	110
Table 21 Multiple Regression when the HMS-PA Model 1 Included among Males....	111
Table 22 Multiple Regression when the HMS-PA Model 1 Included among Females.	112
Table 23 Multiple Regression when the HMS-PA Model 2 Included.....	113
Table 24 Multiple Regression when the HMS-PA Model 2 Included among Males....	114
Table 25 Multiple Regression when the HMS-PA Model 2 Included among Females.	115
Table 26 Multiple Regression when the HMS-PA Model 3 Included.....	116
Table 27 Multiple Regression when the HMS-PA Model 3 Included among Males...	119



Table 28 Multiple Regression when the HMS-PA Model 3 Included among Females.	119
Table 29 Multiple Regression when the HMS-HE Model 1 Included.....	120
Table 30 Multiple Regression when the HMS-HE Model 1 Included among Males....	122
Table 31 Multiple Regression when the HMS-HE Model 1 Included among Females.	122
Table 32 Multiple Regression when the HMS-HE Model 2 Included.....	123
Table 33 Multiple Regression when the HMS-HE Model 2 Included among Males....	124
Table 34 Multiple Regression when the HMS-HE Model 2 Included among Female...	126
Table 35 Multiple Regression when the HMS-HE Model 3 Included.....	127
Table 36 Multiple Regression when the HMS-HE Model 3 Included among Males....	129
Table 37 Multiple Regression when the HMS-HE Model 3 Included among Females.	129

## LIST OF FIGURES

Figure 1	The Two Crucial Junctions in the Path from Motivation to Action.....	7
Figure 2	The Theory of Planned Behavior.....	14
Figure 3	The Health Action Process Approach.....	20
Figure 4	Maddux’s Integrated Model.....	21
Figure 5	A Proposed Model of Health Motivation-General Model.....	36
Figure 6	The Scree Plot of the HMS-PA Model 1.....	41
Figure 7	The Scree Plot of the HMS-PA Model 2.....	45
Figure 8	The Scree Plot of the HMS-PA Model 3.....	48
Figure 9	The Scatter Plot of the HMS-PA Model 1 and the HSDI.....	51
Figure 10	The Scatter Plot of the HMS-PA Model 1 and the SMI.....	51
Figure 11	The Scatter Plot of the HMS-PA Model 2 and the HSDI.....	52
Figure 12	The Scatter Plot of the HMS-PA Model 2 and the SMI.....	52
Figure 13	The Scatter Plot of the HMS-PA Model 3 and the HSDI.....	53
Figure 14	The Scatter Plot of the HMS-PA Model 3 and the SMI.....	53
Figure 15	The Scree Plot of the HMS-HE Model 1.....	55
Figure 16	The Scree Plot of the HMS-HE Model 2.....	60
Figure 17	The Scree Plot of the HMS-HE Model 3.....	64
Figure 18	The Scatter Plot of the HMS-HE Model 1 and the HSDI.....	65
Figure 19	The Scatter Plot of the HMS-HE Model 1 and the SMI.....	66
Figure 20	The Scatter Plot of the HMS-HE Model 2 and the HSDI.....	66
Figure 21	The Scatter Plot of the HME-HE Model 2 and the SMI.....	67
Figure 22	The Scatter Plot of the HMS-HE Model 3 and the HSDI.....	67
Figure 23	The Scatter Plot of the HMS-HE Model 3 and the SMI.....	68
Figure 24	A Proposed Model of Health Motivation-Measurement Model.....	70
Figure 25	HMS-PA Model 1 1 <sup>st</sup> Order CFA.....	78
Figure 26	HMS-PA Model 1 2 <sup>nd</sup> Order CFA.....	79
Figure 27	HMS-PA Model 2 1 <sup>st</sup> Order CFA.....	82
Figure 28	HMS-PA Model 2 2 <sup>nd</sup> Order CFA.....	86
Figure 29	HMS-PA Model 3 1 <sup>st</sup> Order CFA.....	87
Figure 30	HMS-PA Model 3 2 <sup>nd</sup> Order CFA.....	89
Figure 31	HMS-PA Model 3 2 <sup>nd</sup> Order CFA Modified.....	90
Figure 32	HMS-HE Model 1 1 <sup>st</sup> Order CFA.....	94
Figure 33	HMS-HE Model 1 2 <sup>nd</sup> Order CFA.....	96
Figure 34	HMS-HE Model 2 1 <sup>st</sup> Order CFA.....	97
Figure 35	HMS-HE Model 2 2 <sup>nd</sup> Order CFA.....	100
Figure 36	HMS-HE Model 2 Tested with 4 Factors 2 <sup>nd</sup> Order CFA.....	101
Figure 37	HMS-HE Model 3 1 <sup>st</sup> Order CFA.....	103
Figure 38	HMS-HE Model 3 2 <sup>nd</sup> Order CFA.....	105
Figure 39	HMS-HE Model 3 2 <sup>nd</sup> Order CFA Modified.....	106

## ACKNOWLEDGEMENTS

Life is a journey, with ups and downs, joys and sorrows. Pursuing a doctorate degree is also a journey of joys and sorrows. Some people stop their journey for their own reasons. Some people continue and accomplish this journey. I am one of the people who persist. However, this is not my own success. This is the success of all the people who helped me, encouraged me, and supported me along the way to my Ph. D. The first person I would like to thank is Dr. Murray G. Millar for his guidance, support, and inspiration during the entire process. He provided a very friendly environment to work on what I was interested in and was very open to my opinions. I appreciate that very much. In addition, my sincere appreciation goes to my committee members, Dr. David Copeland, Dr. Clayton Silver, Dr. Cortney Warren, and Dr. Rebecca Nathanson, for their valuable time and thoughtful comments and suggestions on my proposal and dissertation. I have learned a great deal from them as well.

Nobody can succeed without the help and support of their friends. My friends were with me on my way to achieving my Ph. D. I would like to express my sincere gratitude to them. They are Dr. Rebecca Warner, Dr. Paje-Manalo, Leila, Dr. Cari Moorhead, Dr. Pablo Chavajay, and Dr. Cathy Angelillo. I give special thanks to Dr. David Mellor for his support during the process and help with my professional growth. I also extend my sincere thanks to the friends whom I did not mention in this short paragraph.

I also would like to acknowledge Dr. Colleen Parks and Dr. Randy Stiles for their help with my data collection. Some of my graduate student colleagues and my research assistants helped me with the data collection or data entry for my dissertation as well. I

greatly appreciate the assistance of Andrea Schoen, Rachel Davis, Roni Glover, Tom Steiner, Nina Brathwaite, Relita Blas, Jennifer Rounds, Kim Sherwood, and Nicole Thomete during the data collection and entry process.

With all my heart, I would like to thank my parents, my brother, and sister-in-law for their unconditional support and help during the difficult times. I love you all! To all the people who contributed to this process, you will be remembered and blessed. Thank you all very much again!

## CHAPTER 1

### INTRODUCTION

Health behaviors refer to any activities that individuals take to maintain, restore, and improve their health or preventing diseases. For instance, exercise, diet, self-examination, washing hands, and brushing teeth are all health related behaviors (e.g., Conner & Norman, 1996). Health behaviors are critical to the survival and reproduction of human beings. Research indicates that unhealthy behaviors (e.g., smoking, drinking, unprotected sexual behavior) increased mortality dramatically (e.g., Belloc, 1973; Breslow & Enstrom, 1980; Conner & Norman, 1996; Hamburg, Elliott, & Parron, 1982; Koop, 1983).

According to the World Health Organization (2000), millions of children die from diseases that can be prevented just by improving personal hygiene (e.g., washing hands after using restroom and before meals), such as diarrheal disease. Health behaviors will improve individuals' health and the chance of survival. For instance, according to the Department of Public Health Service of the United States (1979, 1980), exercise and physical fitness are one of 15 behavior interventions which may reduce death and disease.

Health motivation is one of the most important determinants of healthy behaviors as shown in previous research. For instance, health motivation (or its components) has been included in many health behavior theories (e.g., Protection Motivation Theory (Rogers, 1983; Rogers & Prentice-Dunn, 1997), Theory of Planned Behavior (Ajzen, 1985, 1988, 1991), Health Action Process Approach (Schwarzer, 1992)) and empirical studies have demonstrated the important role of health motivation in health behaviors (e.g., Alexy, 1985; Fisher, Fisher, Williams, & Malloy, 1994; Hall, 1983; McAuley, Wraith, &

Duncan, 1991; Steptoe & Wardle, 1999). However, health motivation has not been systematically studied yet, even without a widely accepted definition. Therefore, the present study aimed to propose a definition and a theoretical model of health motivation and to develop a corresponding scale to measure it. The second purpose of the present research was to investigate to which extent health motivation predicts health behaviors. It was hoped that it could increase our ability to promote health behaviors by explicating the relationship between health motivation and health behaviors, and that this study could be a springboard for further theoretical and empirical studies.

The following sections review previous theoretical research on motivation, the prominent theories of health behavior that included health motivation as a component, and empirical studies on health motivation. Then, two studies were conducted. Study 1 focused on developing scales designed to measure health motivations associated with physical activities and healthy food choice and examined the construct validity using Exploratory Factor Analysis. Study 2 tested the construct validity again by using Confirmatory Factor Analysis, and investigated the extent to which health motivation (as measured by the scales developed in Study 1) predicted physical activities and healthy food choice. Then, the conclusion and discussion were presented.

## CHAPTER 2

### MOTIVATION

#### Theories of Motivation

Motivation is a dynamic inner process that produces an internal force that energizes and orients individuals to select preferred behaviors and try to fulfill pre-set goals. Individuals usually have different motives at one time (e.g., achievement, affiliation, health, religion) and their action is guided by one or more than one of their motives. The goal oriented motivation process includes several sequential stages. First, individuals generate motivational tendencies towards certain goals based upon certain personal or environmental factors. Second, among these tendencies, individuals make plans for salient ones which are most important for them. Third, those salient tendencies motivate individuals to take actions to achieve them. The last stage is a volition stage. Individuals persist in their action and work towards the ending point of their motivational tendencies established at the first stage. Individuals may be able to fulfill their goals at this stage, but they may not due to many factors, for instance, they give up or are interrupted before achieving the goals.

The understanding of motivation has evolved over time and is characterized by diversity. One way to categorize the distinct theories of motivation is to describe it by influential psychological schools. In early last century, Freud, the founder of the psychoanalytic school and father of psychotherapy, believed that people were driven by aggression and sex (Freud, 1915/1963). Lewin (1935) in his expectancy-value theory proposed that motivation is a function of the expectation that the behavior will produce

specific outcomes and the value of these outcomes. Similarly, Vroom (1964) believed that an action is directed by instrumentality that ensures the happening of desirable consequences and nonoccurrence of undesirable effects. Kelly (1962) perceived motivation as a personal construct which guides individuals' action. Finally, Maslow (1970) believed that motivation is the integration of emergence of the desire, the actions it stimulates, and the satisfaction that is produced by the accomplishment of the goal object.

Recently, motivation has been construed in terms of "personal action constructs" (Little, 1999). Such personal action constructs include personal strivings, goals or pursuits that an individual is trying to accomplish (Emmons, 1986) or states of having a particular unsatisfied goal (Klinger, 1975). Although these theories are distinct, components of initiation, goal-directedness, intention, and persistence of behavior have always been the key components (Halisch, & Kuhl, 1987).

Motivation is conceptualized as a dynamic process by many researchers. For instance, Maslow postulated three stages of motivation: appearance of desire, action, and satisfaction of goal accomplishment. Murray (1964) proposed two major components of motivation: drive and goal. The drive "refers to the internal process that goads a person into action"; and reaching a particular goal terminates a motivation (Murray, 1964, p. 7-8). Later, in the book of, "*Motivation and Action*," Heckhausen (1991) described such a process in detail. As can be seen in Figure 1, the path from motivation to action involves three intermediate processes: resultant motivational tendency, intention formation, and initiation of action. According to Heckhausen (1991), normally several motivation



tendencies may be active at the same time, and only the strongest resultant motivation is translated into action. A resultant motivation tendency itself must evolve into an intention to strive individuals to perform an appropriate action (Heckhausen, 1991). After intentions formed, one intention will be implemented because anticipated opportunities are favorable for it (Heckhausen, 1991).

Similar to Heckhausen's perspective on motivation, Gollwitzer (1990; 1993) proposed a model of action phases for his goal theory. This model describes distinct objectives or tasks within the course of wish fulfillment. Sequentially, these objectives are: setting preferences between or among wishes, making plans for goal-directed actions, bringing initiated actions to a successful ending, and evaluating action outcomes (Gollwitzer, 1990; 1993; Gollwitzer & Oettingen, 1998). Originally, the purpose of this model was set to identify potential difficulties individuals may encounter when trying to bring wishes and desires into reality (Gollwitzer, 1990; 1993; Gollwitzer & Oettingen, 1998), but it is a good example to show the process theory of motivation.

Several concepts such as goals, intentions, volitions, and values have been used interchangeably with motivation. To understand motivation, it is essential to specify similarities and differences among these terms. A goal is the object or aim of an action and motivation is goal-directed. Thus, a goal is a conceptual ending point of motivation. Kuhl (1987) defined intention as "an activated plan to which an actor has committed herself or himself" (p. 282). According to Nuttin (1987), intentions are part of motivational process as instrumental goals or aims, and are selected or preferred to achieve the goals. Heckhausen and Kuhl (1985) broke motivational process into two

successive psychological states: motivation (predecisional state) and volition (postdecisional state). According to them, the motivation state involves the decision making process, whereas volition concerns how and when to implement the decision which has been made (Gollwitzer, 1987; Heckhausen & Kuhl, 1985). Although values involve things that individuals desire, it is a mixture of their needs, social norms, and social demands, and it emphasizes what people ought to do; whereas motivation indicates what people want to do or strive to do (Emmons, 1989).

### Measures of Motivation

Traditionally, researchers used questionnaires and thematic measures to assess individuals' motivation. An example of this type of questionnaire is the Personality Research Form (PRF; Jackson, 1999). The PRF is composed of 22 subscales, which represent 20 motives and one social desirability and one infrequency scale. This scale is based upon Murray's need theory and it has six different forms (Jackson, 1999). Individuals who take this questionnaire are instructed to make judgments on statements with "True" (if they agree with a statement) or "False" (if they do not agree with a statement). An example of a thematic measure is the Thematic Apperception Test (TAT; Murray, 1943). The TAT consists of 31 cards, including 30 cards and one blank card (Murray, 1943). Participants are asked to tell a story about a card. Then their stories are analyzed and their motivation are revealed according to certain criteria; for example, if a

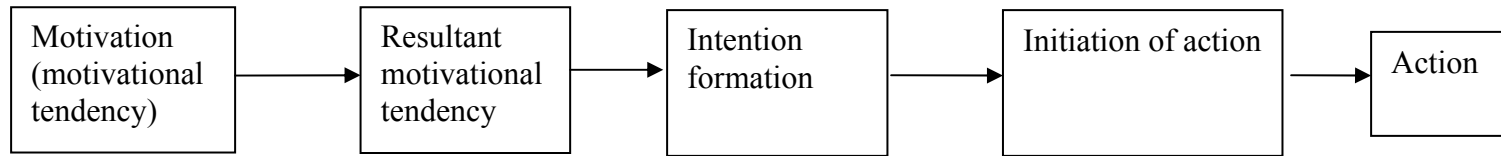

*Figure 1.* The Two Crucial Junctions in the Path from Motivation to Action.

Source: Heckhausen, 1991, p. 11. © Springer-Verlag Publishing.

story is about striving to achieve something or working on something persistently, then achievement motivation should be coded (Murray, 1943). The assumption of this type of test is that participants' inner needs can be projected into the stories they write.

Recently, a new approach of measuring motivation by assessing individuals' acted plans (e.g., personal strivings (Emmons, 1986)) has been applied to this field. For personal striving technique, participants are asked to complete an incomplete sentence, formatted as "I typically try to \_\_\_\_\_." called personal strivings (Emmons, 1986). An example of personal striving is "I typically try to get good grades." Their strivings are coded according to a motivation coding schema (e.g., the Comprehensive Motivation Coding System (Xu, Mellor, Xu, & Duan, 2008)), and then participants' motives are revealed. Because personal strivings are the action aspect of motivation, it can represent individuals' motivation (Emmons, 1986; 1999).

### Health Motivation

In many previous studies, researchers defined and examined health motivation (or motive). For example, Cox (1982) believed that health motivation is a multidimensional subsystem which involves the processes of choice, need for competency, and self-determination in one's health. In their theoretical research on human motivation, Xu, et al. (2008) defined health motivation as "characterized by a strong desire to exercise; to eat well; to live in a healthy environment; to stay in shape, and to be calm and tranquil while sleeping well and avoid stress" (p. 20). Researchers originally used this definition code personal strivings. Although the above two definitions do cover some important

components of health motivation, they do not emphasize the ultimate goals of health motivation such as maintaining or improving health. Furthermore, the latter is too specific to serve as a definition, which should be general and can be applied to a wide variety of situations.

It is unfortunate that there is not a widely accepted definition of health motivation because theoretical and empirical research has shown impact of health motivation on health behaviors. For instance, Sherman, Mann, and Updegraff (2006) suggested that motivational orientations affect health behavior change. Also, Cox (1982; 1986) emphasized the importance of motivation in explaining health behavior and stated that intrinsic motivation should be a primary factor for health behavior. In addition, Croyle (1992) suggested that motivation often biased individuals' appraisal of health threat which affected individuals' health behaviors.

To better understand previous research on the role of health motivation the theories that include health motivation are briefly reviewed. Then, previous empirical research on the relationships between health motivation and health behaviors (physical activities and healthy food choice) are presented. Finally, measurement approaches used to assess health motivation and health behaviors are discussed.

## CHAPTER 3

### A BRIEF REVIEW ON HEALTH MOTIVATION

#### Theories of Health Behavior that Include Health Motivation

##### *Health Belief Model (HBM)*

The Health Belief Model (HBM, Rosenstock, 1974) has been one of the most widely used theoretical frameworks in the field of health behavior since 1970s (Strecher, Champion, & Rosenstock, 1997). The original HBM consists of five constructs: perceived susceptibility, perceived severity, perceived benefits, perceived barriers, and cues to action (Strecher, et al., 1997). Perceived susceptibility and perceived severity determine the threat perception component of this model, and perceived benefits, perceived barriers, and cues to action determine the behavioral evaluation component of this model (Sheeran & Abraham, 1996). Becker, Haefner, and Maiman (1977) added health motivation in a later version of HBM. After that, two additional components were included, which were demographic and socio-psychological variables (Becker, 1990). According to this model, if individuals perceive the threat of disease (e.g., their vulnerability to disease and the severity of disease), and are aware of the benefits of performing certain behaviors (e.g., away from disease), but there is no (or few) barriers prevent individuals' actions. As a result, individuals may be motivated to behave healthily.

The HBM has been applied to a wide range of health behaviors and a wide range of populations (Sheeran & Abraham, 1996). According to Sheeran and Abraham (1996), the HBM has been applied into the following three areas: preventive health behaviors (e.g.,

diet, exercise, smoking), sick role behaviors (e.g., medical regimens), and clinic use (e.g., physician visits). Janz and Becker (1984) reviewed 46 articles involving the HBM and found that the results substantially supported the HBM. Perceived barriers were found to be the most powerful predictive factor of the HBM (Janz & Becker, 1984). However, in a more recent review Sheeran and Abraham (1996) concluded that the HBM was weakly associated with health behaviors.

Although, this model has provided researchers a very useful theoretical framework to understand a variety of behaviors, it has limitations. One of the criticisms this model received is that its components are poorly defined (Armitage & Conner, 2000; Sheeran & Abraham, 1996). Further, a meta-analysis of studies involving the HBM has found that, although all correlations between HBM and behavior were statistically significant, the effect sizes were small (Harrison, Mullen, & Green, 1992; Armitage & Conner, 2000). Sheeran and Abraham (1996) explain the low predictive validity of the HBM by pointing out that there are insufficient definitions of its components, simplified framework, and no combinational rules for the components.

#### *Protection Motivation Theory (PMT)*

The PMT was originally developed to explain the effects of fear arousing on health behaviors (Rogers, 1983; Rogers & Prentice-Dunn, 1997). This model encompassed a number of concepts from the HBM, and it has been revised many times, and the later revisions have received the most attention (Boer & Seydel, 1996; Rogers & Prentice-Dunn, 1997). The main components of the PMT are: “(a) severity: How severe are the consequences of the disease?; (b) vulnerability: How probable is it that I will contact the

disease?; (c) response efficacy: How effective is it the recommended behavior in avoiding the negative consequences?; (d) self-efficacy: To what extent am I able to perform the recommended behavior successfully?; (e) protection motivation: Am I intending to perform the recommended behavior?; and (f) protective behavior: Performing the recommended behavior” (Boer & Seydel, 1996, p.99)

The model of PMT consists of two appraisal processes: threat appraisal process and coping appraisal process (Armitage & Conner, 2000; Boer & Seydel, 1996; Rogers & Prentice-Dunn, 1997). The threat appraisal process of the PMT is very similar to that of the functions of perceived vulnerability and perceived severity in the HBM. The coping appraisal process is determined by individuals’ expectation of removing the threat (response efficacy) and the belief in their ability to perform such behaviors (self-efficacy). Protection motivation is co-determined by the threat appraisal and coping appraisal which act as a mediator that arouse, maintain, and direct health behavior (Boer & Seydel, 1996).

The PMT has been widely used to predict both health behaviors and non-health behaviors (Boer & Seydel, 1996, Floyd, Prentice-Dunn, & Rogers, 2000). In their meta-analysis on 65 studies cross over two decades, Floyd et al. (2000) found that PMT predicted health behavior with an overall moderate effect size ( $d^+ = .52$ ). In addition, each component of PMT was significantly associated with healthy attitude and behaviors. Boer and Seydel (1996) found that PMT predicted intention to engage in preventive health behaviors. For example, the PMT accounted for 36% variance of the intention to participate in breast cancer screening (Boer & Seydel, 1996). Also, the components of response efficacy and self-efficacy are found to play a role in the adoption of preventive



health behaviors (Boer & Seydel, 1996; Rippetoe & Rogers, 1987; Stanley & Maddux, 1986). However, other evidence has been less supportive. In a different meta-analysis, Sheeran and Orbell (1998) revealed that average correlations for all components of the PMT ranged from small to medium, and indicated the low predictive power of the PMT. Despite this low power, the components of the PMT were found to be sensitive to health interventions (Hodgkins, Sheeran, & Orbell, 1998).

### *Theory of Planned Behavior (TPB)*

The Theory of Planned Behavior (TPB; Ajzen, 1985, 1988, 1991) is an extension of the Theory of Reasoned Action (TRA; Fishbein & Ajzen, 1975; Ajzen & Fishbein, 1980). It suggests that the intention to act is a function of the attitude towards the behaviors, the subjective norm, and perceived behavioral control. The attitude towards behaviors is a function of individuals' salient behavioral beliefs. The subjective norm is a function of normative beliefs which represents significant others' preferences about performing a behavior. Perceived behavioral control is one's judgment on whether he or she can successfully perform a behavior (Ajzen, 1985, 1988, 1991; Conner & Sparks, 1996). The TPB suggests that health behavior is "a linear regression function of intentions and perceived behavior control" (Fishbein & Ajzen, 1975; Ajzen & Fishbein, 1980; Conner & Sparks, 1996, p. 123). Figure 2 depicts the relationships among components of the TPB.

The TPB has been applied to explain and predict a variety of behaviors such as exercise, alcohol consumption, health screening attendance, breast/testicle examination, food choice, smoking, and sexual behaviors (Conner & Sparks, 1996; Hardeman, et al., 2002). Most of the findings support the TPB. For example, in their review of its

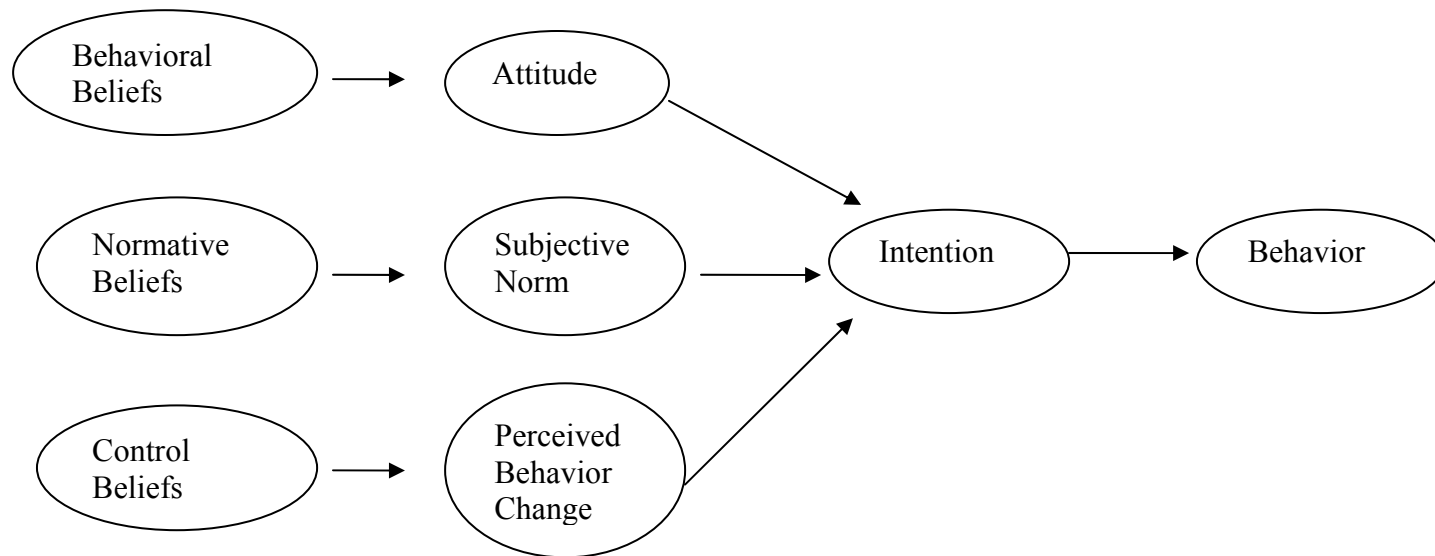

Figure 2. The Theory of Planned Behavior.

Source: Armitage and Conner, 2001, p. 472. Reproduced with permission from the British Journal of Social Psychology, ©

The British Psychological Society.

application to health related behaviors, Godin and Kok (1996) indicated that the TPB accounted for 41% of variance in intention and 34% in health-related behaviors.

Armitage and Conner (2001) found that the TPB could explain 27% and 39% of the variance in behavior and intention in their review of 185 independent studies. In his review on the predictive capacity of the TPB in exercise, Blue (1995) concluded that the TPB was a very useful theoretical framework in predicting exercise behaviors. To examine the predictive power of the TPB in intentions to use condoms, Sheeran and Taylor (1999) reviewed 67 independent samples. They found that the TPB accounted for 42% of the overall variance of behavior intentions for condom use. However, a number of studies suggested that the subjective norm was a weak predictor of intention (e.g., Armitage & Conner, 2001; Hardeman, et al., 2002).

Although researchers paid attention to the TPB and research supported it, the TPB has its limitations. In real research setting, it is problematic to accurately measure one's salient beliefs because it is difficult to ascertain which beliefs are salient and which are not (Conner & Armitage, 1998; Conner & Sparks, 1996). The potential beliefs provided by researchers may not be the salient beliefs of the individuals (Conner & Armitage, 1998). Further, the relationships between the TPB and health behavior are much more complex than allowed for by the model. For instance, the intensity of a behavioral intention varies and does not always cause a person to perform a desired behavior (Conner & Armitage, 1998). Moreover, behaviors may be affected by spontaneous attitudes or attitudes towards other things rather than health behaviors (Conner & Armitage, 1998; Conner & Sparks, 1996; Hardeman, et al., 2002). For example, one day

a person who is on a diet suddenly is attracted to a roasted and nice smelling chicken, and eats the chicken rather than stick to his or her diet plan because he or she thinks it would not be a serious problem if just one exception. Also, as Conner and Sparks (1996) pointed out that, in addition to the components of the TPB, there are many other factors which affect individuals' health behaviors.

### *Health Action Process Approach*

Schwarzer (1992) developed the Health Action Process Approach (HAPA) to distinguish between a motivation stage and an action or maintenance stage in health behaviors. This theoretical model suggests that health behaviors consist of two phases: motivation phase and action phase (see Figure 3) (Schwarzer, 1992). The left part of the diagram represents the motivation phase and the right side represents the action phase. According to Schwarzer (1992), at the motivation stage, individuals develop “an intention to either adopt a precaution measure or change risk behaviors in favor of other behaviors” (p. 234). He believes that self-efficacy expectancies and outcome expectancies are two major predictors of an intention and that the perceived severity and vulnerability co-determine the threat (Schwarzer, 1992). The action phase of this model is composed of cognitive, behavioral, and situational levels (Schwarzer, 1992). The cognitive level is the focus of this phase which instigates and controls the action, but situational barriers and opportunities should be considered too (Schwarzer, 1992). For example, on the one hand, smoking in the presence of a quitter causes a stressful situation for the quitter which may weaken his or her volition; on the other hand, if the spouse of the quitter quits, then the social support situation will strength the quitter's volition of

quitting (Schwarzer, 1992).

Schwarzer and Fuchs (1996) applied the HAPA to food choice. Their findings indicated that intention defined in the HAPA was a strong predictor of food choice behaviors, with a path coefficient of .50, as well as self-efficacy, with a path coefficient of .37 (Schwarzer and Fuchs, 1996). Intention was mainly predicted by positive outcome expectancies and self-efficacy, with path coefficients of .58 and .29 respectively (Schwarzer and Fuchs, 1996). Similar to the limitations of above theoretical models, the HAPA fails to clearly define variables involved in the model. This is particularly a problem for the variables in the action phase. Despite these problems, the model recognizes the important differences between motivation and action (Armitage & Conner, 2000).

#### *An Integrated Model*

Based on the TPB and several other health behavior models (e.g., Protection Motivation Theory, Health Belief Model), Maddux (1993) proposed an integrated model of health behavior, called a revised theory of planned behavior. Figure 4 shows this integrated model (Maddux, 1993). This revised theory of planned behavior suggests that health behavior is the result of three major components: behavioral intentions, self-efficacy for new behavior, and cues-to-action (Maddux, 1993). According to Maddux (1993), “intentions are the most immediate and powerful determinant of behavior;” “self-efficacy influences behavior directly or indirectly through its influences on intentions;” and “situational cues will influence behavior directly when a behavior has been performed repeatedly in the presence of the same cues and is prompted automatically by

these cues (referred to cues-to-action)” (p. 133).

Maddux (1993) believed that it is important to differentiate attitudes toward the current (unhealthy) behavior from new (healthy) behavior because the analysis of benefits and costs of the current and new behaviors influences individuals’ behavior changes. Self-efficacy for new behavior replaces perceived behavioral control in TPB which incorporates both self-efficacy expectancy and outcome expectancy. According to Maddux (1993), the distinction between self-efficacy expectancy and outcome expectancy should be acknowledged and they should be measured respectively rather than being measured as a hybrid; also, because outcome expectancy has been included in the assessment of attitudes toward the behavior, it would be redundant to measure it in both constructs. Furthermore, it is convenient to separate expected social outcomes from other types of expected nonsocial outcomes (Maddux, 1993). Situational cues trigger individuals’ intention to behave, “but not automatically prompt the behavior itself,” called cues-to-decision (Maddux, 1993, p. 135). When the decision making process and the behavior occur repeatedly in the presence of the same cues, cues-to-decision becomes cues-to-action and behaviors are changed (Maddux, 1993).

Besides the above theoretical models, there are other models which have been developed to explain and predict health behaviors; however, they are not as influential as the above models. For example, the Health Motivation Model developed by McEwen (1993) focuses on the motivation of health promotional behaviors (McEwen, 1993). The first facet of the Health Motivation Model is the knowledge of health and potential health threats, which influences perceived severity, perceived susceptibility, and perceived value

of action, and these three variables interact with each other (McEwen, 1993). Their interaction filters through modifying factors of background variable, external aids/hindrances, and internal aids/hindrances (McEwen, 1993). These factors together affect individuals' perceptions respectively or conjointly and then individuals may be motivated to behave healthily (McEwen, 1993). Unfortunately, there is little research on this model.

#### *A Comparison among the Theoretical Models*

As can be seen in previous discussion and Table 1, the reviewed theories have similarities and differences on a theoretical level. One major similarity among these motivation theories of health behavior is that they share a common assumption that the anticipation of a negative health outcome and the desire to avoid this outcome or reduce its impact produce motivation for self-protection. For example, perceived susceptibility and severity are included in HBM, PMT, and HAPA; health intention is included in both TPB and HAPA; health motivation is included in a later version of HBM and PMT. These models differ in several ways. First, although these models share some components, they have distinct components. For example, control beliefs are included in TPB and HAPA, but neither in HBM nor in PTM. Self-efficacy is included in PTM and HAPA, but not in the other two models. Second, the components included in these models are organized differently. For the HBM, its constructs are organized as a catalog of variables that contribute to health behaviors. For other theories, they are organized as continuous processes attempting to match cognitive process and select coping alternative or perform preferred behaviors.

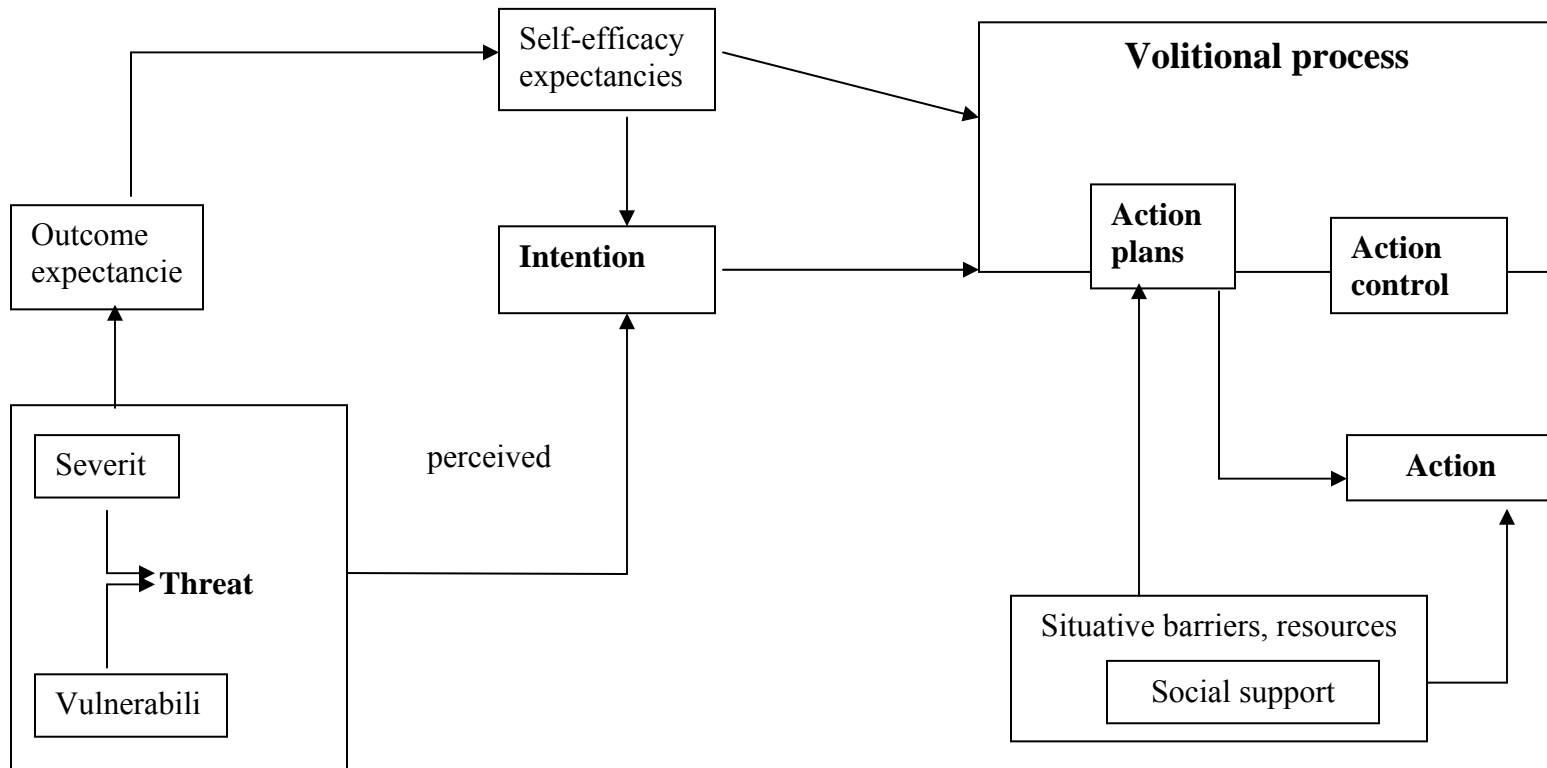
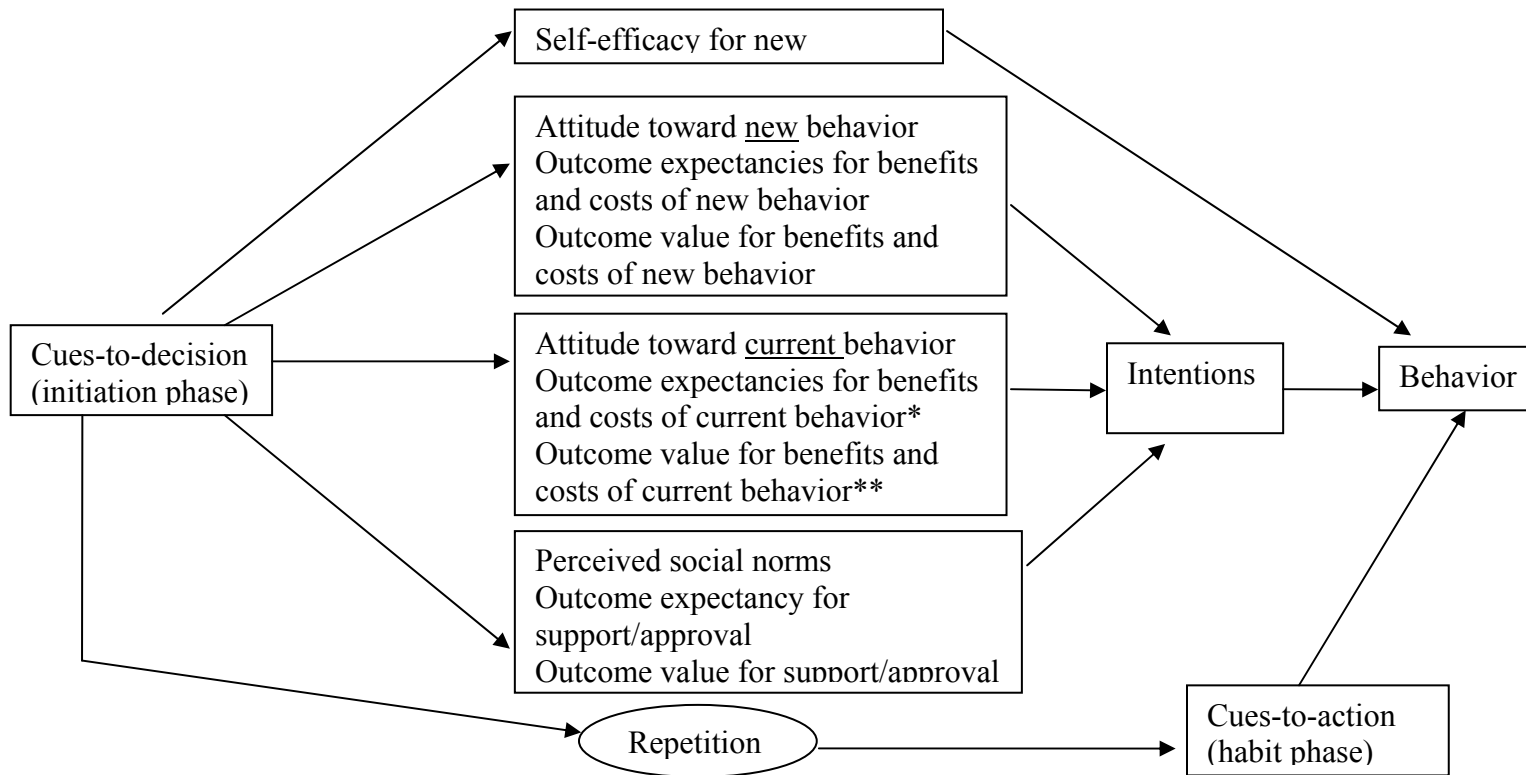

Figure 3. The Health Action Process Approach.  
 Source: Schwarzer, 1992, p. 233. © Hemisphere Publishing Corporation.





\* includes perceived vulnerability to negative health consequences.

\*\* includes perceived severity of negative health consequences.

Figure 4. Maddux's Integrated Model.

Source: Maddux, 1993, p. 134. © Taylor & Francis.

Researchers have conducted studies to compare the predictive power between different theories. According to Norman and Conner's (1996) review, many comparisons have shown similar levels of predictive power among these theories, although some differences have been found. For instance, in their study on the determining factors of women's intentions to conduct breast self-examination and to take a Pap test. Hill, Gardner, and Rassaby (1985) found that the HBM predicted slightly more variance in each case than the TRA did. But, Hill et al. pointed out that these differences might be due to measurement issues. Among the factors suggested by these theories numerous studies have found that self-efficacy is the most important predictor of preventive intentions or behaviors (Dzewaltowski, 1989; Norman, & Conner, 1996; Seydel, Taal, & Wiegman, 1990).

According to the contradicting findings shown in previous studies, it is clear that the above models do not predict or explain health behaviors in a perfect fashion. First of all, the factors affect individuals' health behaviors are more than those discussed in the previous sections. Health behaviors are in a dynamic system which is not just a combination of a group factors. Therefore, a dynamic approach would be appropriate for theoretical construction of health behaviors, which includes the stages of contemplation, initiation, and maintenance of behavior. To be specific, Norman and Conner (1996) proposed a four-stage health behavior model, which involves pre-contemplation, decision making or motivation, planning, and maintenance stages. They posited the main objects of each stage. This dynamic approach includes factors such as past behavior, moral norms, self-efficacy, and self-identity (Norman, & Conner, 1996).

## Empirical Studies Involving Health Motivation

### *Health Motivation and Physical Activities*

Research has shown that health motivation increases the likelihood of taking health enhancement actions. For example, Song, June, and Kim (2004) conducted a study examining whether motivation enhancement would change elders health behaviors. They used traditional Korean dance movements for 6 months, with 4 times per week (Song, et al., 2004). People were grouped into participants or dropouts by the criteria of 80% attendance (Song, et al., 2004). They found that this program improved participants' health motivation and that such enhancement in motivation motivated them to perform health behaviors (Song, et al., 2004).

Based upon Deci and Ryan's (1985) self-determination theory, researchers divided health motivation into intrinsic and extrinsic motivation and examined their relationships with physical activities. For example, McAuley, et al. (1991) demonstrated that intrinsic motivation for aerobic dance was higher among highly efficacious participants than less efficacious participants. Buckworth, Lee, Regan, Schneider, and DiClemente (2007) also found that both intrinsic and extrinsic motivations were highly endorsed in exercise maintenance, but intrinsic motivation contributed to exercise maintenance greater than extrinsic motivation.

Components of health motivation have been demonstrated to be good predictors of physical activities and to enhance physical activities. For instance, health related goals enhance exercise level (e.g., Alexy, 1985). Research has shown that health motivation is a better predictor than many other factors in terms of physical behavior change. For

Table 1

*Comparison among the Models*

Models	Major components and Organization	Strength and Weakness
Health Belief Model	<p>Perceived susceptibility                      Perceived severity → Threat perception                      perceived benefits                      perceived barriers → Behavioral evaluation                      cues to action                      Health motivation (added in a later version)                      Demographic and socio-psychological variable (added in a later version)</p>	<p><b>Strength:</b> a very useful theoretical framework for various behaviors</p> <p><b>Weakness:</b> its components are poorly defined; low predictive validity</p>
Protection Motivation Theory	<p>Severity                      Vulnerability → Threat appraisal                      Response efficacy                      Self-efficacy → Coping appraisal</p>	<p><b>Strength:</b> desirable predictive power in some reported studies; its components are sensitive to health interventions</p> <p><b>Weakness:</b> low predictive power in some studies</p>

Table 1

*Comparison among the Models Continued*

Models	Major components and Organization	Strength and Weakness
Theory of Planned Behavior	<pre> graph LR     BB[Behavioral beliefs] --&gt; Att[Attitude]     NB[Normative beliefs] --&gt; SN[Subjective norm]     CB[Control beliefs] --&gt; PBC[Perceived behavioral control]     Att --&gt; Int[Intention]     SN --&gt; Int     PBC --&gt; Int     Int --&gt; Beh[Behavior]           </pre>	<p><b>Strength:</b> research supports its high predictive power</p>
Health Action Process Approach	<pre> graph LR     S[Severity] --&gt; T[Threat]     V[Vulnerability] --&gt; T     SE[Self-efficacy expectancies] --&gt; MP[Motivation phase]     OE[Outcome expectancies] --&gt; MP     T --&gt; MP     AP[Action plans] --&gt; VP[Volition process]     AC[Action control] --&gt; VP     SB[Situative barriers] --&gt; APH[Action phase]     R[Resources] --&gt; APH     SS[Social support] --&gt; APH     MP --&gt; A[Action]     APH --&gt; A           </pre>	<p><b>Strength:</b> the intention component is a good predictor of healthy food choice behavior</p>
		<p><b>Weakness:</b> poorly defined components</p>

example, a study conducted by Kelly, Zyzanski, and Alemago (1991) illustrated the significant prediction of motivation exercise habits, as well as other five lifestyles (cigarette smoking, dealing with stress, amount and type of food eaten, and use of seat belts, and exercise habits). Duda and Tappe (1988) also demonstrated that personal incentives were significantly associated with individuals' future exercise behaviors.

There are factors which impair health motivation. For instance, Papacharisis and Goudas (2003) examined the effects of gender, attitude towards physical activity, perceived barriers, and intrinsic motivation on a health related program in physical education for middle school students. They found that students' intrinsic motivation was affected by perceived barriers to exercise (Papacharisis & Goudas, 2003).

#### *Health Motivation and Healthy Food Choice*

The relationships between health motivation and food choice are complex because there are many factors impact individuals' food choice, for instance, weight control, price, and flavor. Steptoe and Wardle (1999) demonstrated that there were significantly positive correlations between motive for dietary choice and fiber intake and negatively correlations between dietary motive and fat consumption. In their study, motive for dietary choice was assessed by the Food Choice Questionnaire (Steptoe, Pollard, & Wardle, 1995). This scale consists of nine subscales and 36 items (Steptoe, et al., 1995). They nine subscales are Health, Mood, Convenience, Sensory Appeal, Natural Content, Price, Weight Control, Familiarity, and Ethical Concern (Steptoe, et al., 1995). Participants were instructed to rate each item on a 4-point scale, ranging from "1" not important at all to "4" very important (Steptoe, et al., 1995; Steptoe & Wardle, 1999). An

item example for the Health subscale is that “It is important to me that the food I eat on a typical day contains a lot of vitamins and minerals” (Steptoe & Wardle, 1999). The internal consistencies of the nine subscales range from .72 to .86 (Steptoe & Wardle, 1999).

## Measures of Health Motivation and Health Behaviors

### *Measures of Health Motivation*

Questionnaires are the most widely used technique to measure health motivation and usually employ seven-point Likert and five-point Likert scales. Measures of health motivation differ in terms of the domain of interests and their formats, as well as different understandings of motivation. The following are specific scales of health motivation.

Cox (1985) used Self-determination theory to develop the Health Self Determinism Index (HSDI) to measure motivation in health behaviors. This scale is composed of 17 items divided into four subscales of self-determined health judgments, self-determined health behavior, perceived competency in health matters, and internal-external cue responsiveness.

Another health motivation questionnaire is Self-Motivation Inventory, which consists of 40 self-report items (Dishman, & Ickes, 1981; Dishman, Ickes, & Morgan, 1980). Participants are instructed to rate general motivation statements on 5-point scales, ranging from “unlike me” to “like me” (Dishman, et al., 1980). The reported internal consistency of this measure was .81 (Brenes, Strube, & Storandt, 1998). Moorman’s enduring motivation scale is another one (Moorman, 1990). This scale consists of five domains and

is composed of 21 items (Moorman, 1990). The reported internal consistency of this scale was .92 (Moorman, 1990). It can be adapted into different fields of interests. The health motivation assessment inventory (McEwen, 1993) might be another option for assessing general health motivation. This instrument was based on McEwen's Health Motivation Model discussed above, which included three parts (McEwen, 1993). An item example is "I believe a regular exercise program improves cardiac fitness" (McEwen, 1993). In addition, single item measures have also been used by researchers to assess health motivation (e.g., Kalichman, Picciano, & Roffman, 2008).

#### Measures of Health Behaviors

##### *Measures of Physical Activities*

Different types of measures have been used to assess individuals' physical activities, for instance, questionnaires with one or multiple items and dichotomic response measures. The Seven Day Physical Activity Recall Questionnaire (Blair, 1984) is one of the questionnaires developed to assess one's physical activities with multiple items. Participants are instructed to recall their physical activities in mornings, afternoons, and evenings for one week (Blair, 1984). An example of one item measure is "How often have you participated in one or more physical activities, lasting 20 to 30 minutes per workout session, in your free time during the last 3 months?" (Godin, Desharnais, Jobin, & Cook, 1987). The responses given are: Never, Less than once a month, About once a month, About two or three times a month, About one or two times a week, and Three or more times per week (Godin, et al., 1987). A reported two-week test-retest reliability of this scale is .64 (Godin, et al., 1987). A measure with a dichotomic response format is



that participants are instructed to indicate “Yes” or “No” for regular exercise in each decade of life beginning in their childhood (Brenes et al., 1998). One “Yes” response is coded with 1 (Brenes et al., 1998). The final scores are the sum of all the “1”s divided by the number of decades (Brenes et al., 1998). A higher score suggests a stronger habit of lifetime exercise (Brenes et al., 1998). Also, internet-based assessment tools for physical activity behaviors have been applied into this field (Evers & Carol, 2007).

### *Measures of Food Choice*

Different approaches have been used to measure individuals’ food choice behaviors. For instance, questionnaires have been used to assess food choice (e.g., Richetin, Perugini, Prestwich, & O’Gorman, 2007). Observation of actual food choice has also been used to measure participants’ food choice (e.g., Richetin, et al., 2007). In addition, an interview technique has been applied to assess individuals’ food choice. For instance, Campbell, Crawford, and Hesketh (2007) obtained children’s food choice by interviewing their parents. Furthermore, Evers and Carol (2007) also used internet-based assessment tool for measuring food choices.

### *Measurement Issues*

Undoubtedly, the measures of health motivation helped researchers to study health behaviors or health motivation related topics. However, these measures have their weakness too. For example, researchers measure health motivation under the guidance of their intuitive knowledge about it because there is no consensus on the definition of health motivation. As a result, different versions of health motivation and distinct measures of health motivation have emerged. Furthermore, the construct of health

motivation is complicated because it involves many aspects of health related components (e.g., past experience, knowledge of health, expectations). Also, health motivation has different contents in different areas of our life, for instance, in daily physical activities, daily food choice, and daily disease protection actions (e.g., condom use, hand washing). Therefore, it is difficult to give a general definition to health motivation that is effective everywhere.

The second weakness is that one-item scales have been frequently used in many studies. One-item scores usually do not have qualified reliabilities. If the reliability of the scores of a scale is questionable, then they do not have desired validity. Therefore, in future, if it is possible, researchers should try not to use one item scales. Even using multiple-item scales, researchers should test their reliabilities and validities in their pilot studies before they apply them to their formal studies if the scales are not standardized.

The third weakness, as can be seen in other questionnaires, is that social desirability may bias the responses to the questionnaires. Also, it is easy for participants to guess the purposes of this type of research. Consequently, participants may try to please experimenters by responding the items in a way that favors for the anticipated results. Therefore, it would be desirable to develop or use implicit measures that are usually ambiguous to participants. For example, the Implicit Association Test may be used to assess participants' attitude to health related opinions or beliefs or attitudes. The Striving technique discussed in previous section may be used to assess health motivation.

Better measures for health behaviors have been developed because it is easier to conceptualize a health behavior than health motivation. The techniques (e.g.,

questionnaires, self-monitoring booklet) discussed in previous section are appropriate approaches to assess health behaviors. Researchers might balance the pros and cons of each approach and choose the one that can fulfill their goals perfectly.

#### Limitations in Previous Research and Purposes of the Present Study

As illustrated by the above discussion, although health motivation has been included in the theoretical models of health behavior, it was ill defined. Furthermore, a variety of terms have been used to represent health motivation, for instance, healthy goals, concerns, and intentions. These diverse understandings have resulted in poorly measuring health motivation in empirical studies. Therefore, this study aimed to propose a definition and a theoretical model of health motivation, to develop a health motivation scale to measure this proposed construct, and to investigate to which extent health motivation predicted health behaviors. To achieve these goals, two studies were conducted. Study 1 proposed a definition and a theoretical model of health motivation, developed health motivation scales to measure this model, and tested the construct validity using Exploratory Factor Analysis and examined the discriminant validity. Study 2 examined the construct validity using Confirmatory Factor Analysis and the predictive validity.

## CHAPTER 4

### STUDY 1

In this section, a definition and a theoretical model of health motivation were proposed. The Health Motivation Scale in Physical Activities and the Health Motivation Scale in Healthy Eating were developed to measure health motivation in these two types of behaviors. Exploratory Factor Analysis and correlation analysis were conducted to test the quality of the scales.

#### A Proposed Theoretical Model of Health Motivation

Based upon the theoretical and empirical research on motivation and health motivation, a definition of health motivation is offered. Health motivation produces the inner force which energizes and orients individuals to select such behaviors that can maintain and promote individuals' health and can prevent them from diseases. The inner force acts as an "engine" of a machine. It produces power for individuals' behavior system. The inner force in this definition is very different from intrinsic motivation because intrinsic-extrinsic motivation is a way to categorize human motivation. Intrinsic motivation is what makes people do something without external inducement. If a person does something without external inducement such as money, we can say this person is intrinsically motivated. Both internal and external sources can form an inner force. Internal sources refer to health related self-concepts, such as health beliefs, health value, and health self-efficacy. External sources refer to pressure given by significant others, facilities, and weather. For example, if a person believes that doing physical activities can

maintain or improve his or her health and prevent him or her from disease, he or she may try to find a way to involve in physical activities (e.g., go to a gym regularly). If a person's mother encourages him or her to engage in physical activities, he or she may strive to do that. The force that drives the person to do physical activities is the inner force discussed above.

Health motivation is a process which involves several different stages like Heckhausen's processes described in Figure 1 and Gollwitzer's action stages (see Figure 5). At the first stage, people generate their healthy related motivation tendencies. Personal and environmental factors influence forming these tendencies. Personal factors include self-efficacy, beliefs, health values, knowledge about health, and others, and environmental factors involve peer pressure, facilities in the community, weather, and others. The second stage involves making plans or forming health intentions. At this stage individuals solve the problems such as how and when to implement action to achieve goals or fulfill wishes established in the first stage. The third stage involves the initiation of purposeful actions. For example, if individuals want to improve their health (first stage) and decide to exercise to achieve this goal (second stage), then at this stage they should go to gym or perform any form of exercise. The last stage involves volition or persistence in the behavior. To exercise once or twice cannot achieve one's goal of improving health. That is, to realize the goals or wishes, individuals have to be persistent in their exercise practice. Personal and environmental factors impact not only the first stage, but also all the other stages. Any changes in personal or environmental factors may cause changes of health motivation, and consequently result in changes in health behavior.

Compared with Cox and Xu et al's definition of health motivation, this newly proposed definition has its advantages. For example, although Cox (1982) pointed it out that health motivation is a multidimensional subsystem and listed three processes: choice, need for competency, and self-determination in one's health, this definition does not clearly point out the ultimate goals of health motivation. A motivation, as agreed by motivation psychologists, is goal-oriented. This newly proposed definition clearly and specifically includes the ultimate goals of health motivation. Xu et al.'s definition of health motivation was originally developed to code personal strivings. As can be seen from the definition in an early paragraph, this definition is too specific, which involves very specific daily activities. It is assumed that a definition should be able to generalize to a wide variety of situations. From these perspectives, this newly proposed definition can serve as the definition of health motivation better than the two existing ones.

#### Health Motivation Scales in Physical Activities and Healthy Eating

Two Health Motivation Scales were developed to measure health motivation in physical activities and healthy eating respectively. These two scales are Likert scales and based upon the above definition and model, which consists of four subscales: Health Motivational Tendency, Health Intention, Action Initiation Motivation, and Persistence Motivation (Volition). Subscales are composed of six to nine items closely relevant to the targeted construct, with 30 items in total for each of the scales. To ensure the content validity of the scales, the original scales were sent to four experts for comments and suggestions. The scales were revised based upon their feedback. Then, the revised scales

were sent out for evaluation and comments again. After that, the scales were further revised. Finally, the items of final scales were randomized.

## Methods

### *Participants*

Two hundred and fifty nine undergraduate volunteers were recruited from the Subject pool of Psychology Department at University of Nevada, Las Vegas and a few classes in the same departments. Among them, seventy eight were males; one hundred and sixty four were females; seventeen were not identified. They aged from 18 to 49, with the mean age of 20.83 ( $SD = 4.33$ ). Their weight ranged from 95 to 272 pounds, with the mean weight of 150.93 pounds ( $SD = 35.34$ ), with the height ranging from 59 to 76 inches ( $M = 66.37$  inches,  $SD = 3.98$ ). The minimum BMI was 16.82 and the maximum was 40.35, with a mean of 23.94 ( $SD = 4.36$ ). Most of the participants (45.5%) were White; 6.9% were African American, 9.9% were Hispanic; 7.3% were Native American; 13.3% were Asian; and 17.2% were not-identified or other. Participants were asked to rate their health on a 7-point scale, ranging from “1” (Not healthy at all) to “7” (Extremely healthy). Their health rating ranged from 3 to 7, with a mean of 5.35 ( $SD = 1.06$ ).

### *Measures*

#### *Health Motivation Scales*

The self-developed Health Motivation Scales described above were administered (see Appendix A). An item example of physical activity subscale is “I tend to engage in

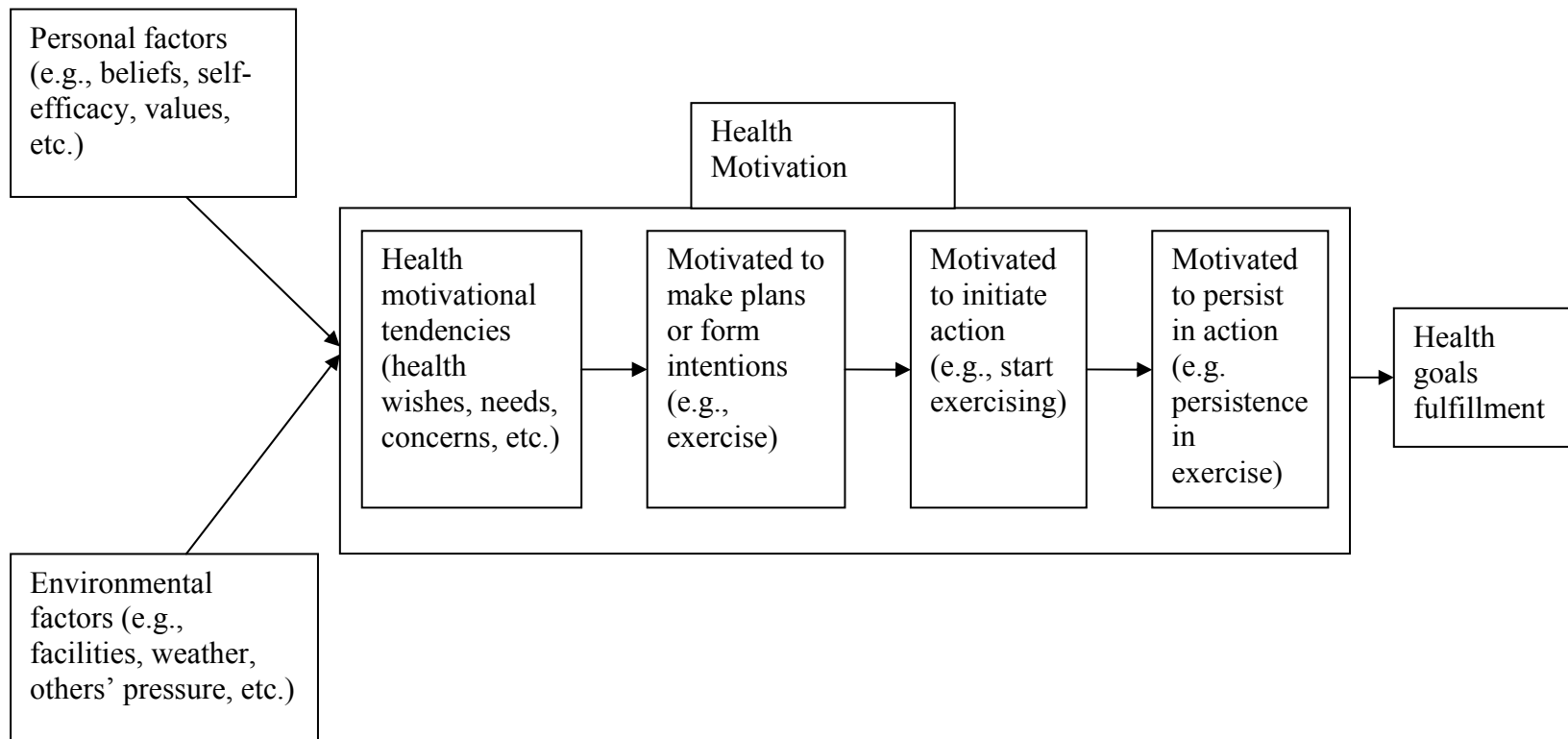

Figure 5. A Proposed Model of Health Motivation-General Model.



physical activities to be healthy.” An example of healthy food choice subscale is “I will start to engage in healthy eating if I want to be healthy.”

#### *Health Self Determinism Index (HSDI)*

Convergent and discriminant validity is another criteria often used to test the validity of a measurement. Convergent validity refers to that if a scale does measure the same construct as the other scale does, then the scores obtained using these two scales should be correlated. On the contrary, discriminant validity refers to that if a scale does not measure the same construct as the other scale does, then the scores obtained using by these two scales should not be correlated. Therefore, two health motivation scales – the Health Self Determinism Index (Cox, 1985) and the Self-Motivation Inventory (Dishman & Ickes, 1981) were selected and their scores were to be correlated with the two newly developed health motivation scales.

The Health Self Determinism Index (Cox, 1985) was based upon the Self-determination theory. This scale consists of four subscales of self-determined health judgments, self-determined health behavior, perceived competency in health matters, and internal-external cue responsiveness. The internal reliabilities of the four domains were .75, .75, .67, and .69 (Cox, 1985). This scale is composed of 17 items. Nine of the 17 items have a 5-point Likert response scale, ranging from “1” (most extrinsic motivation) to “5” (most intrinsic motivation). The rest of eight items have the same Likert response scale, except for ranging from “1” (most intrinsic motivation) to “5” (most extrinsic motivation) (Cox, 1985). An item example is “For me, it takes more willpower than I have to do the things that I know are good for my health.”

### *Self-Motivation Inventory (SMI)*

The Self-Motivation Inventory (Dishman & Ickes, 1981) consists of 40 self-report items. Participants were instructed to rate general motivation statements on 5-point scales, ranging from “very much unlike me” to “very much like me” (Dishman & Ickes, 1981). An item example is “I can persist in spite of pain or discomfort.” The reported internal consistency of this measure was .81 (Brenes, et al., 1998).

### *Procedure*

The proposal of this study was approved by the IRB of the University of Nevada, Las Vegas. The scales were ordered as HMS, HSDI, and SMI, and HMS, SMI, and HSDI with the former for odd experiment ID and the latter for even experiment ID. Experimenters conducted the experiment with the permission of the professors. They were told that researchers were interested in their opinions or daily activities on physical activities and food choice, and that they just needed to fill out some scales, and that they would be offered research credit or extra course credit for their participation. Then, they consented participating in this study if they would like to stay and participate. After the consent, they were instructed to complete the scales. Finally, they were debriefed.

## Results

### *Health Motivation Scale in Physical Activities*

#### *Internal Consistency*

The overall internal consistency alpha for the scores of the Health Motivation Scale in Physical Activities (HMS-PA), called HMS-PA model 1, was .97. Alpha values for the

scores of the four subscales of health motivational tendency, health intention, health action initiation motivation, and persistence motivation were .90, .87, .86, and .92 respectively. The correlations between the hypothesized factors ranged from .76 to .87, with a mean of .81.

### *Construct Validation*

#### *Exploratory Factor Analysis*

Exploratory Factor Analysis (EFA) was conducted to determine whether the hypothesized 4-factor structure underlie the scores of the Health Motivation Scale in Physical Activities. The four hypothesized factors were introduced in the theoretical model establishment section and scale development section, which were health motivational tendency, health intention, health action initiation motivation, and persistence motivation.

A traditionally preliminary extraction was conducted using principal components analysis (PCA), maximum likelihood (ML) factoring and principal axis factoring (PAF). The extraction criterion was to extract four factors because the model was hypothesized to be composed of four factors. Oblimin rotations were used to determine factors because of the high correlations among the original factors. By comparison between ML and PAF solutions, PAF oblimin solution ( $\delta = 0$ ) was selected to report because it was simpler and closer to hypothesized factor structure than the ML resolution. The four factors accounted for 60.59% of the variance. The communalities were generally high, ranging from .40 to .78.

To confirm the number of factors, four different tests were conducted, including using

eigenvalue greater than 1 as the extraction criteria, scree test, Minimum Partial Average test (MAP; Velicer, 1976), and Parallel Analysis (PA; Horn, 1965; Cota, Longman, Holden, & Rekken, 1993). Using eigenvalue greater than 1 as the extraction criteria, when PAF was applied with rotation of oblimin ( $\delta = 0$ ), the same results as the above were obtained. That is, four factors were extracted and same factor pattern was resulted. However, the scree test indicated one factor (see Figure 6). The MAP test indicated three factors. Further, the PA test suggested one factor in the data as only the first eigenvalue was greater than the 95<sup>th</sup> percentile of the random eigenvalue (see Table 2). When three factors were extracted, no clear factor pattern was identified. The one factor might yield meaningful information, so the one factor model, called HMS-PA model 1\*, was tested in Study 2. These different tests have distinct implications of the number of the factors that underlie the data. By comparison among these different tests, the four-factor solution can be retained because it was most meaningful.

The pattern coefficients and structure coefficients are shown in Table 3. The pattern coefficients indicated that the four extracted factors roughly corresponded to the four domains established in a previous paragraph. Seven items of persistence motivation domain loaded on this factor, with their loadings ranging from .35 to .73. One item's loading was low (.22). For the other three factors, four corresponding items loaded on each of them respectively, with their loadings ranging from .35 to .91. However, as can be seen in Table 3, some items had very low loadings on any factors, for example, HMT 8. Some items loaded on more than one factors such as HI1. Some designated items did not load on their designated factors (e.g., AIM3 and HMT4) (see Table 3). These results

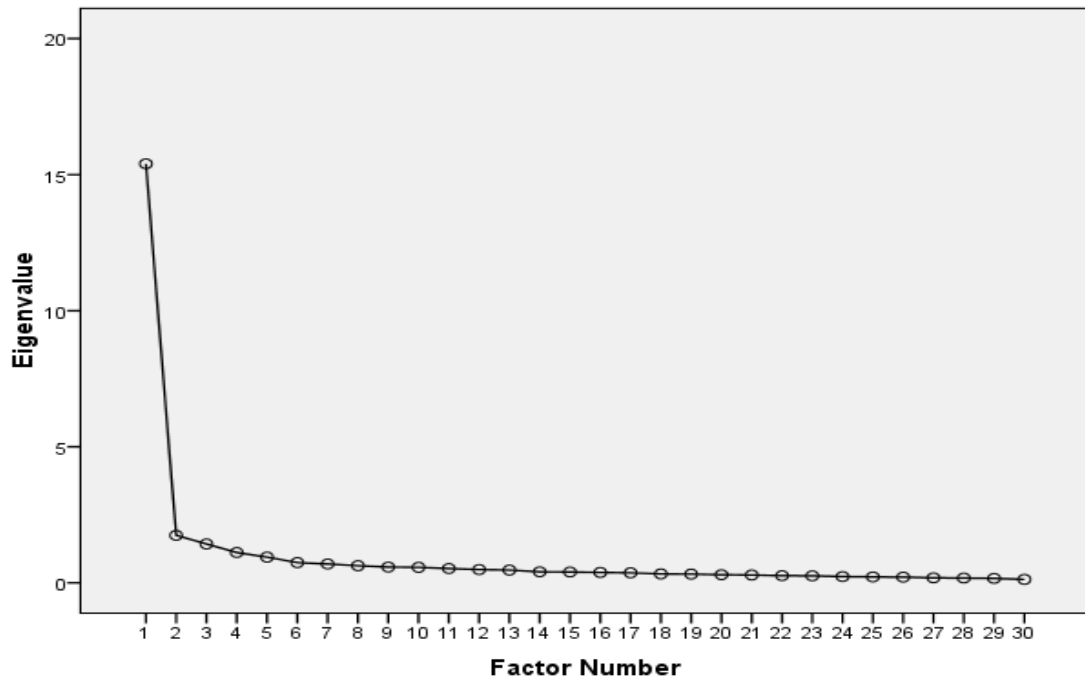

Figure 6. The Scree Plot of the HMS-PA Model 1.

Table 2

*The 95<sup>th</sup> Percentile of the Random Eigenvalues and Eigenvalues from the Original Data (for the HMS-PA Model 1)*

Root	95 <sup>th</sup> Percentile Random Eigenvalue	Eigenvalue from the Original Data
1	1.79	15.05
2	1.66	1.36
3	1.58	1.07
4	1.51	0.73
5	...	...

indicated that some items might be deleted. This original model was called HMS-PA Model 1.

Based upon the above findings, 17 items were deleted due to their low loadings or their loadings on more than one factor. The items loaded on their designated factors and had loadings no less than .45 were retained. The deleted items were AIM1, HMT6, HMT4, AIM3, HMT1, AIM2, HMT8, HMT5, PM6, PM1, PM7, HI5, HI1, HI2, HMT7, AIM4, and AIM5. After deleting these items, the same extraction and rotation factoring methods were applied to the remaining items; that is, using the PAF with oblimin rotation method ( $\delta = 0$ ). The four factors accounted for 75.26% of the variance. The communalities were generally high, ranging from .44 to .77. The results suggested that this factor structure was well defined for all the items, with loading ranging from .45 to .88 (see Table 4). This model was called HMS-PA Model 2.

To further confirm the number of factors in this model 2, the same factor determination tests were conducted, including using eigenvalue greater than 1 as the extraction criteria, scree test, Minimum Partial Average test (MAP; Velicer, 1976), and Parallel Analysis (PA; Horn, 1965; Cota, Longman, Holden, & Rekken, 1993). Using eigenvalue greater than 1 as the extraction criteria, when PAF was applied with rotation of oblimin ( $\delta = 0$ ), two factors were identified. In the first factor, the health motivation tendency, health intention, and action initiation went together; the persistency motivation was the second factor. However, the scree test indicated one factor (see Figure 7). The MAP test indicated two factors. When two factors were extracted, the first three factors (health motivation tendency, health intention, and action initiation motivation)

Table 3

*Pattern Coefficients (PC) and Structure Coefficients (SC) Obtained from Principal Axis Factoring Solution with Oblimin Rotation (N = 259) for the HMS-PA Model 1*

	Factor 1 <sup>b</sup>		Factor 2		Factor 3		Factor 4	
	PC	SC	PC	SC	PC	SC	PC	SC
PM4 <sup>a</sup>	<u>0.73</u>	0.81						
PM3	<u>0.66</u>	0.76						
AIM3	0.66	0.70						
PM5	<u>0.66</u>	0.81						
PM8	<u>0.60</u>	0.72						
HMT6	0.51	0.73	0.39					
PM2	<u>0.49</u>	0.76						
HMT4	0.43	0.75						
AIM2	0.42	0.68			0.30			
HMT1	0.39	0.63						
AIM1	0.39	0.67	0.33					
HMT8	0.56		0.48		0.53		0.58	
HI4			<u>0.72</u>	0.81				
HMT5	0.34		0.72	0.81				
HI3			<u>0.63</u>	0.68				
HI6			<u>0.55</u>	0.69				
HI2			0.35	0.59				
HMT9					<u>0.81</u>	0.78		
PM6					0.60	0.71		
PM1	0.41				0.55	0.79		
HMT2					<u>0.53</u>	0.75		
HMT3			0.34		<u>0.48</u>	0.64		
PM7	0.35				0.43	0.69		
HMT7					0.39	0.57		
HI5					0.38	0.68		
HI1			0.31		0.34	0.68	0.31	0.70
AIM6							<u>0.91</u>	0.84
AIM7							<u>0.78</u>	0.80
AIM4					0.32		0.46	0.66
AIM5							0.38	0.64

*Note.* <sup>a</sup> Letters indicate the domain originally assigned in the HMS. HMT = Health Motivation Tendency, HI = Health Intention, AIM = Action Initiation Motivation, and PM = Persistence Motivation. Loadings larger than .30 are reported. <sup>b</sup>Eigenvalues after rotation for the four factors from the left to the right were 10.65, 8.42, 10.01, and 10.08 respectively. The total explained variance was 65.65%.

Table 4

*Pattern Coefficients (PC) and Structure Coefficients (SC) Obtained from Principal Axis Factoring Solution with Oblimin Rotation (N = 259) for the HMS-PA Model 2*

	Factor 1 <sup>c</sup>		Factor 2		Factor 3		Factor 4	
	PC	SC	PC	SC	PC	SC	PC	SC
HMT3 <sup>a</sup>	0.69	0.77						
HMT9	0.60	0.76						
HMT2	0.60	0.67						
HI4			0.66	0.79				
HI3			0.50	0.66				
HI6	0.30		0.45	0.62				
AIM6					-0.88	-0.86		
AIM7					-0.81	-0.83		
PM4			0.31				-0.81	-0.83
PM3							-0.69	-0.78
PM8							-0.69	-0.78
PM5							-0.66	-0.77
PM2	0.34						-0.56	-0.77
Label <sup>b</sup>	Health motivation tendency		Health intention		Action initiation motivation		Persistence motivation	

*Note.* <sup>a</sup> Letters indicate the domain originally assigned in the HMS. HMT = Health Motivation Tendency, HI = Health Intention, AIM = Action Initiation Motivation, and PM = Persistence Motivation. Loadings larger than .30 are reported. <sup>b</sup> Label indicates the suggested factors. <sup>c</sup> Eigenvalues after rotation for the four factors from the left to the right were 5.58, 5.50, 5.31, and 3.80 respectively, with the total explained variance of 69%.



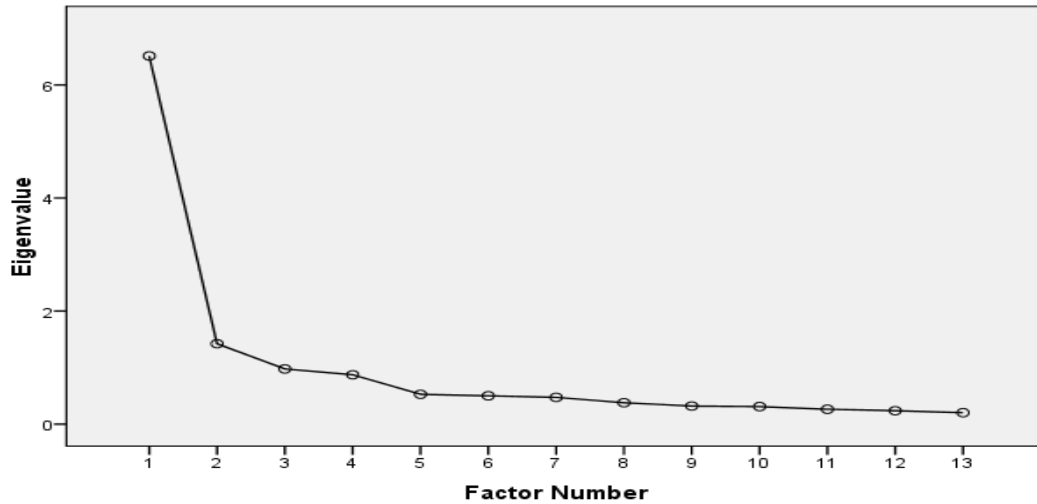

Figure 7. The Scree Plot of the HMS-PA Model 2.

went together and became the first factor, and the persistency motivation was the second factor. Further, the PA test suggested one factor in the data as only the first eigenvalue was greater than the 95<sup>th</sup> percentile of the random eigenvalue (see Table 5). The one factor might yield meaningful information, so the one factor model, called HMS-PA model 2\*, was tested in Study 2. These different tests have distinct implications of the number of the factors that underlie the data. By comparison among these different tests, the four-factor solution was retained again because of its meaningfulness.

The overall internal consistency alpha for the scores of the HMS-PA model 2 was .92. The alphas for the scores of the four subscales of health motivational tendency, health intention, health action initiation motivation, and persistence motivation were .79, .79, .83, and .90 respectively.

Table 5

*The 95<sup>th</sup> Percentile of the Random Eigenvalues and Eigenvalues from the Original Data  
(for the HMS-PA Model 2)*

Root	95 <sup>th</sup> Percentile Random Eigenvalue	Eigenvalue from the Original Data
1	1.48	6.09
2	1.35	0.97
3	1.28	0.51
4	1.20	0.44
5	...	...

To retain more items and try to see a clearer picture of the model, the cutting criterion was extended to loadings no less than .30. Consequently, 13 items were deleted due to their low loadings. The deleted items were AIM1, HMT6, HMT4, AIM3, HMT1, AIM2, HMT8, HMT5, PM6, PM1, PM7, HI5, and HI1. After deleting these items, the same extraction and rotation factoring methods were applied to the remaining items; that is, using the PAF with oblimin rotation method (delta = 0). The four factors accounted for 60.12% of the variance. The communalities were generally high, ranging from .40 to .76. This model was called HMS-PA Model 3.

The results suggested that this factor structure was well defined for almost all the items, except for AIM4. Item AIM4 loaded on health motivational tendency and action initiation motivation, with a lower loading on its designated factor – action initiation motivation (-.34 vs. .44) (see Table 6). This item is subjected to be reworded in future use.

Table 6

*Pattern Coefficients (PC) and Structure Coefficients (SC) Obtained from Principal Axis Factoring Solution with Oblimin Rotation (N = 259) for the HMS-PA Model 3*

	Factor 1 <sup>c</sup>		Factor 2		Factor 3		Factor 4	
	PC	SC	PC	SC	PC	SC	PC	SC
HMT9 <sup>a</sup>	0.68	0.71						
HMT3	0.67	0.74						
HMT2	0.53	0.74						
HMT7	0.51	0.62						
PM4			-0.82	-0.84			-0.30	
PM3			-0.69	-0.77				
PM8			-0.69	-0.77				
PM5			-0.67	-0.80				
PM2	0.34		-0.56	-0.78				
AIM6					-0.89	-0.86		
AIM7					-0.77	-0.82		
AIM4	0.44				-0.34	-0.50		
AIM5					-0.31	-0.57		
HI4							-0.67	-0.79
HI3							-0.57	-0.67
HI6							-0.49	-0.67
HI2							-0.32	-0.55
Label <sup>b</sup>	Health motivation tendency		Persistence motivation		Action initiation motivation		Health intention	

*Note.* <sup>a</sup> Letters in front of the item number indicate the domain originally assigned in the HMS. HMT = Health Motivation Tendency, HI = Health Intention, AIM = Action Initiation Motivation, and PM = Persistence Motivation. Loadings larger than .30 are reported.

<sup>b</sup> Label indicates the suggested factor name.

<sup>c</sup> Eigenvalues after rotation for the four factors from the left to the right were 5.58, 5.50, 5.31, and 3.80 respectively. The total variance explained by the four factors was 69%.

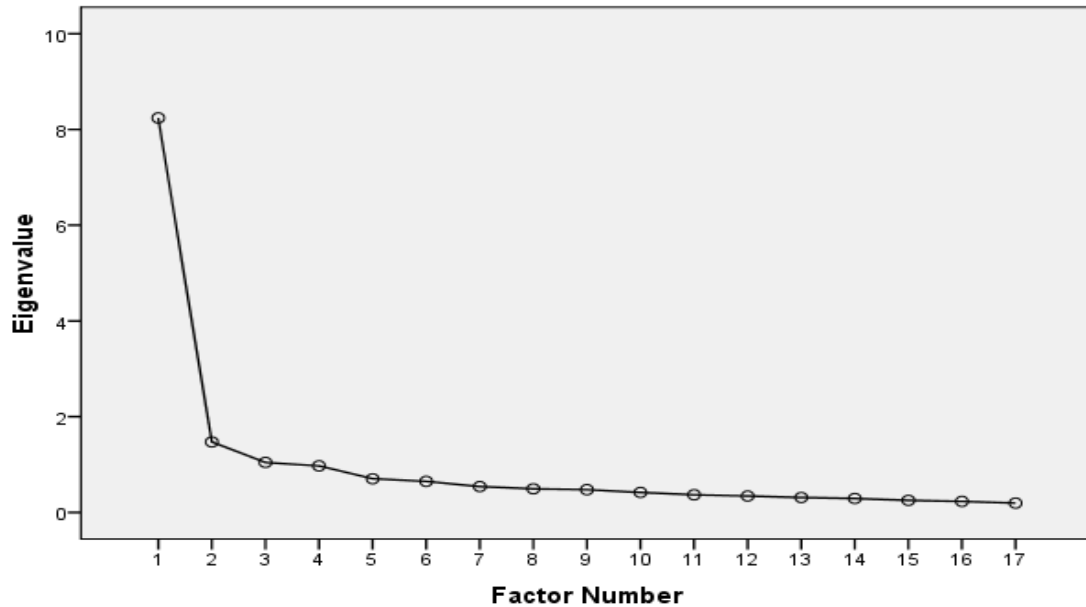

Figure 8. The Scree Plot of the HMS-PA Model 3.

The results suggested that the factor structure of the model 3 in physical activities was well defined for almost all the items, except for AIM4. Item AIM4 loaded on health motivational tendency and action initiation motivation factor, with a lower loading on its designated factor – action initiation motivation (-.34 vs. .44) (see Table 6). This item is subjected to be reworded in future use.

To further confirm the number of factors, three different tests were conducted, including using eigenvalue greater than 1 as the extraction criteria, scree test, Minimum Partial Average test (MAP; Velicer, 1976), and Parallel Analysis (PA; Horn, 1965; Cota

et al., 1993). Using eigenvalue greater than 1 as the extraction criteria, when PAF was applied with rotation of oblimin ( $\delta = 0$ ), three factors were identified. The three factors were health motivation tendency, persistency motivation, and health intention. The hypothesized factor action initiation factor spread in health motivation tendency and health intention, with two items for each. However, the scree test indicated one factor (see Figure 8). The MAP test indicated two factors. Further, the PA test suggested one factor in the data as only the first eigenvalue was greater than the 95<sup>th</sup> percentile of the random eigenvalue (see Table 7). When two factors were extracted, the first three factors (health motivation tendency, health intention, and action initiation motivation) went together and became the first factor, and the persistency motivation was the second factor. This is also meaning because the first three factors involve intentions or thoughts and the second factor involves actual actions. The one factor might yield meaningful information, so the one factor model, called HMS-PA model 3\*, was tested in Study 2. These different tests have distinct implications of the number of the factors that underlie the data. The four-factor solution was retained because of its meaningfulness.

The overall internal consistency alpha for the scores of the HMS-PA model 3 was .93. The alphas for the scores of the four subscales of health motivational tendency, health intention, health action initiation motivation, and persistence motivation were .81, .81, .83, and .90 respectively.

#### *Correlations between the Scores of Three Scales*

To examine the relationship between the HMS-PA and HSDI and SMI, correlation analyses (Pearson  $r$ ) were conducted between the scores of these scales. It was found that

the scores of the HMS-PA Model 1 did not correlate with HSDI and SMI, with correlations of .04 and .02 respectively. The scores of the HMS-PA Model 2 were not related to those of the HSDI and SMI either, with correlations of .06 and .02 respectively. The scores of the HMS-PA Model 3 were not associated with those of the HSDI and SMI either, with correlations of .05 and .01 respectively.

Table 7

*The 95<sup>th</sup> Percentile of the Random Eigenvalues and Eigenvalues from the Original Data (for the HMS-PA Model 3)*

Root	95 <sup>th</sup> Percentile Random Eigenvalue	Eigenvalue from the Original Data
1	1.56	7.81
2	1.44	1.04
3	1.37	0.58
4	1.28	0.55
5	...	...

To further investigate the relationships between the HMS-PA and the HSDI and the SMI, simple scatter plots were drawn between these scales. There were no apparent quadratic relationships between the HMS-PA (including all three models) and the HSDI, and between the HMS-PA (including all three models) and the SMI (see Figure 9 – Figure 14).

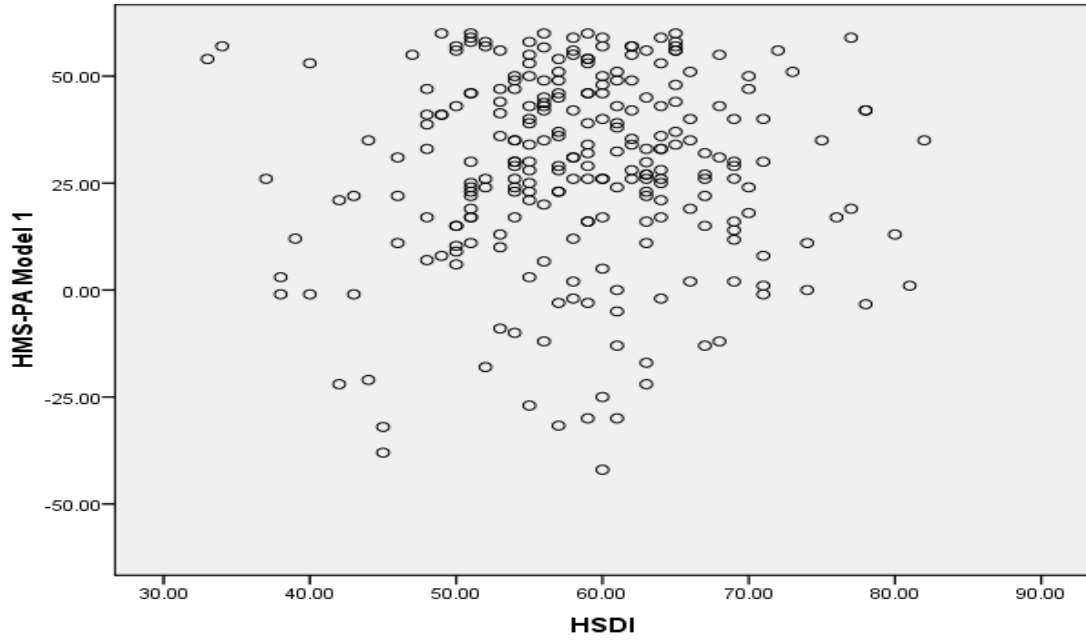

Figure 9. The Scatter Plot of the HMS-PA Model 1 and the HSDI.

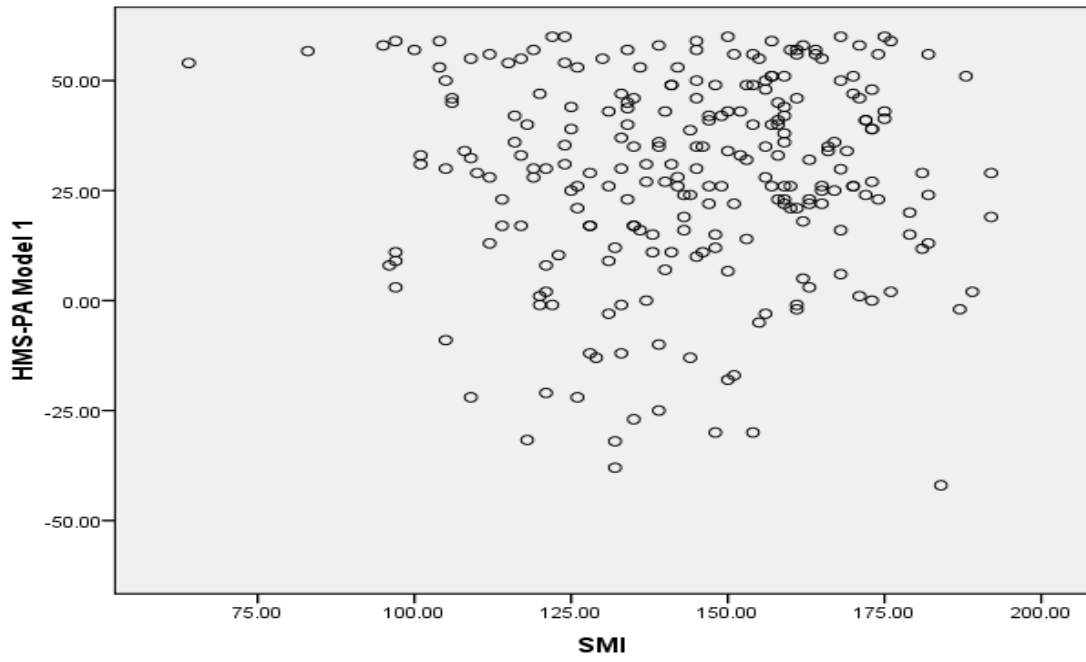

Figure 10. The Scatter Plot of the HMS-PA Model 1 and the SMI.

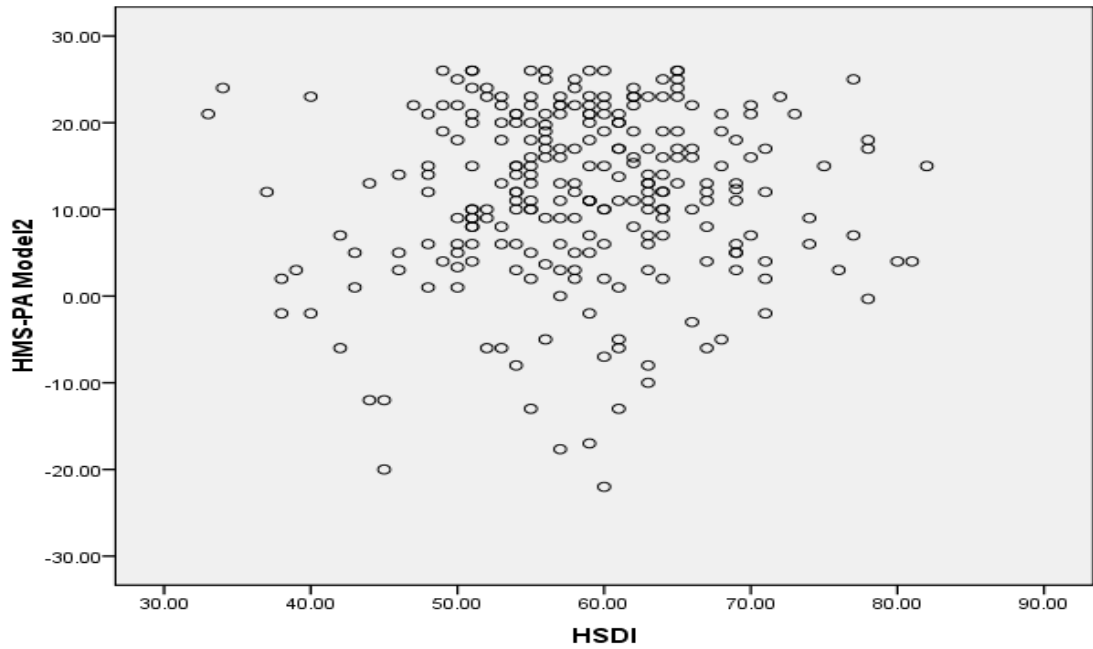

Figure 11. The Scatter Plot of the HMS-PA Model 2 and the HSDI.

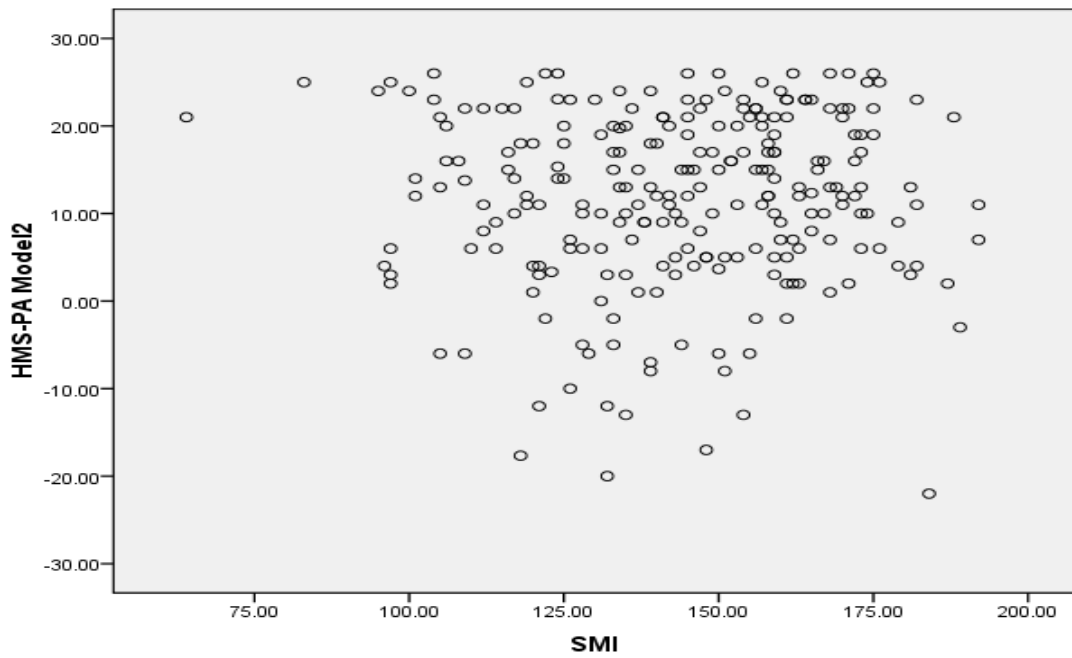

Figure 12. The Scatter Plot of the HMS-PA Model 2 and the SMI.



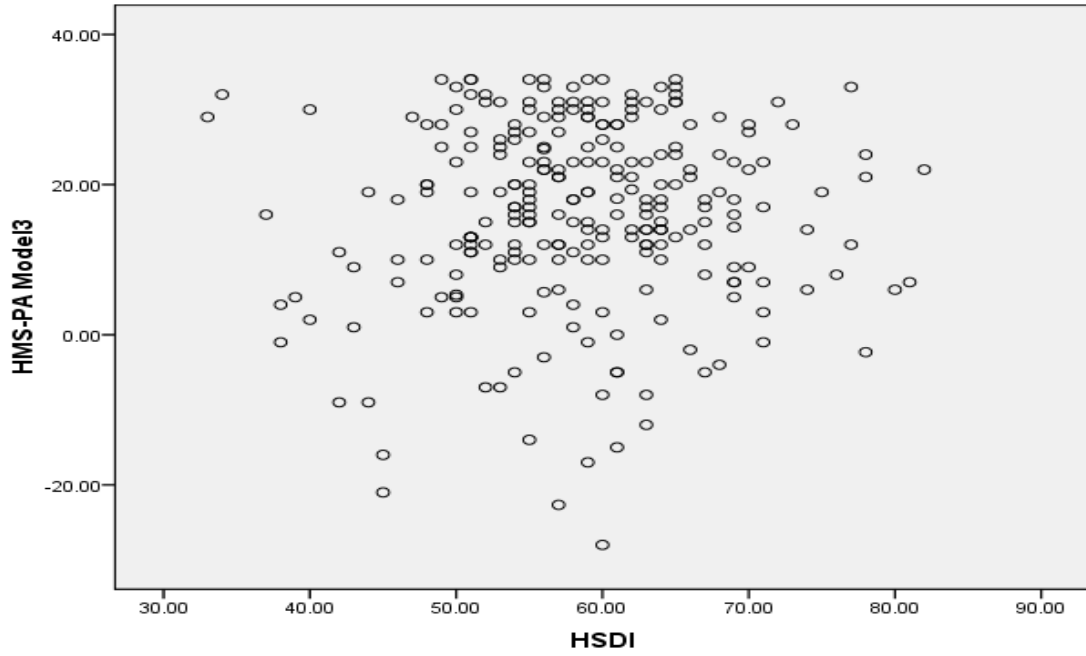

Figure 13. The Scatter Plot of the HMS-PA Model 3 and the HSDI.

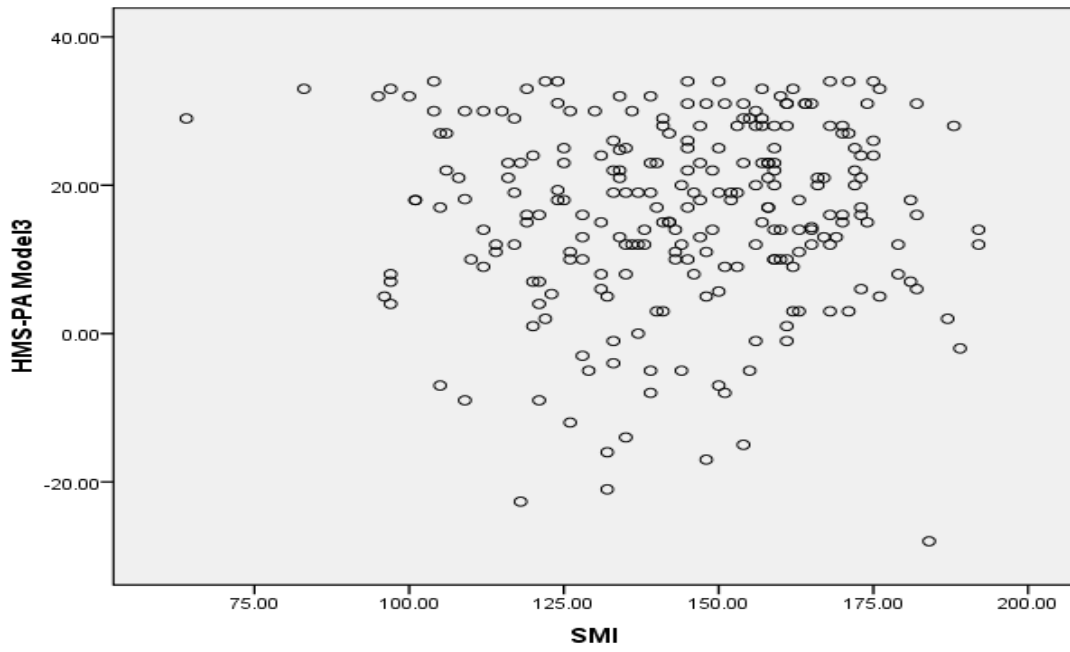

Figure 14. The Scatter Plot of the HMS-PA Model 3 and the SMI.

## *Health Motivation Scale in Healthy Eating*

### *Internal Consistency*

The overall internal consistency alpha for the scores of the Health Motivation Scale in Healthy Eating (HMS-HE), called HMS-HE model 1, was .97. The alphas for the scores of the four subscales – health motivational tendency, health intention, health action initiation motivation, and persistence motivation were .90, .91, .86, and .91 respectively. The correlations between factors ranged from .74 to .92, with a mean of .80.

### *Construct Validation*

#### *Exploratory Factor Analysis*

Exploratory Factor Analysis (EFA) was conducted to determine whether the hypothesized 4-factor structure underlie the scores of the Health Motivation Scale in Healthy Eating. The four hypothesized factors were introduced in the theoretical model establishment section and scale development section, which were health motivational tendency, health intention, health action initiation motivation, and persistence motivation.

A preliminary extraction was conducted using principal components analysis, maximum likelihood (ML) factoring and principal axis factoring (PAF). Oblimin rotations were used to determine factors because of the high correlations among the hypothesized factors. Extracting four factors was the extraction criteria because it was a hypothesized four-factor model. By comparison among PC, ML, and PAF solutions, ML Oblimin solution ( $\delta = 0$ ) was selected to report because it was simpler and closer to hypothesized factor structure. The four factors accounted for 64.05% of the total variance. The communalities were generally high, ranging from .48 to .81.

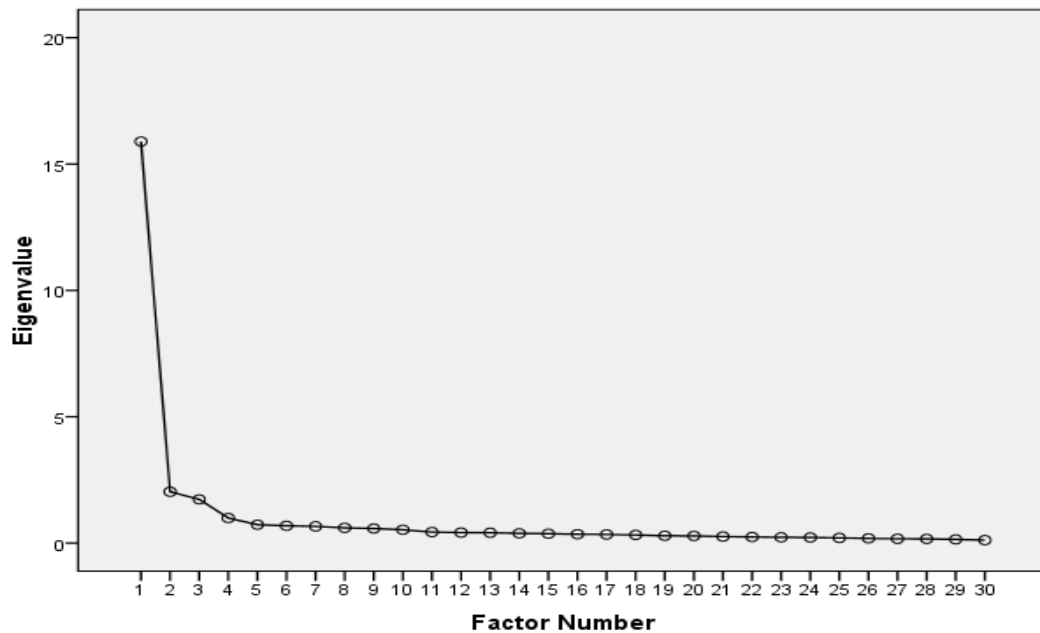

*Figure 15.* The Scree Plot of the HMS-HE Model 1.

To further confirm the number of factors, four tests were conducted, including using eigenvalue greater than 1 as the extraction criteria, scree test, Minimum Partial Average test (MAP; Velicer, 1976), and Parallel Analysis (PA; Horn, 1965; Cota, Longman, Holden, & Rekken, 1993). Using eigenvalue greater than 1 as the extraction criteria, when ML was applied with rotation of oblimin ( $\delta = 0$ ), three factors were identified. However, the scree test indicated one factor (see Figure 15). The MAP test indicated

four factors. Further, the PA test suggested two factors in the data as two eigenvalue from the original data were greater than the 95<sup>th</sup> percentile of the random eigenvalues (see Table 8). The one factor might yield meaningful information, so the one factor model, called HMS-HE model 1\*, was tested in Study 2. These different tests have distinct implication of the number of the factors that underlie the data. By comparison among these different tests, the four-factor solution was retained because it was most meaningful.

Table 8

*The 95<sup>th</sup> Percentile of the Random Eigenvalues and Eigenvalues from the Original Data (for the HMS-HE Model 1)*

Root	95 <sup>th</sup> Percentile Random Eigenvalue	Eigenvalue from the Original Data
1	1.79	15.57
2	1.66	1.69
3	1.58	1.36
4	1.51	0.69
5	...	...

The pattern matrix shown in Table 9 indicates that the four extracted factors roughly corresponded to the four domains established in a previous paragraph. For each of the factors, four corresponding items loaded on them respectively, with their loadings ranging from .36 to .81. However, some items did not load on their designated factors (e.g., PM2 and AIM7) (see Table 9). This model was called HMS-HE Model 1.

Table 9

*Pattern Coefficients (PC) and Structure Coefficients (SC) Obtained from Maximum Likelihood Solution with Oblimin Rotation (N = 259) for the HMS-HE Model 1*

	Factor 1 <sup>b</sup>		Factor 2		Factor 3		Factor 4	
	PC	SC	PC	SC	PC	SC	PC	SC
HMT1 <sup>a</sup>	<u>0.78</u>	0.88						
PM2	0.67	0.81			-0.30			
AIM6	0.63	0.77						
HI1	0.61	0.82						
HMT6	<u>0.50</u>	0.78						
PM7	0.46	0.72					0.35	
AIM7	0.40	0.73	-0.36					
HMT3	0.36	0.73					0.35	
HMT8	0.36				-0.47			
HMT4			-0.91	-0.90				
HI6			<u>-0.81</u>	-0.87				
HI4			<u>-0.77</u>	-0.81				
HI7			<u>-0.71</u>	-0.75				
HMT5			-0.62	-0.75	-0.36			
HI2			<u>-0.60</u>	-0.72				
HI3			-0.37	-0.72			0.40	
PM4					<u>-0.63</u>	-0.74		
AIM2			-0.31		-0.56	-0.72		
PM3					<u>-0.49</u>	-0.67	0.37	
PM5					<u>-0.44</u>	-0.60		
PM8					-0.41	-0.60	0.47	0.65
AIM4							<u>0.78</u>	0.77
PM6							0.70	0.73
AIM1							<u>0.68</u>	0.69
AIM5							<u>0.65</u>	0.74
HMT2							0.58	0.74
HI5							0.55	0.78
PM1							0.49	0.77
AIM3					-0.33		0.48	0.68
HMT7							0.44	0.63

*Note.* <sup>a</sup> Letters indicate the domain originally assigned in the HMS. HMT = Health Motivation Tendency, HI = Health Intention, AIM = Action Initiation Motivation, and PM = Persistence Motivation. <sup>b</sup>Eigenvalues after rotation for the four factors from the left to the right were 11.96, 11.17, 5.68, and 11.20 respectively. The total variance explained by the four factors was 68.83%.

Based upon the above findings, 18 items were deleted due to their miss-loadings or their loadings on more than one factor. The items loaded on their designated factors and had loadings no less than .45 were retained. PM5 was retained, even though its loading was .44 because it loaded on only one factor and the loading was very close to .45. The deleted items were PM2, AIM6, HI1, PM7, AIM7, HMT4, HMT5, AIM2, PM6, HMT2, HI5, PM1, HMT7, HMT3, HMT8, HI3, PM8, and AIM3. After deleting these items, the same extraction and rotation factoring methods were applied to the remaining items; that is, using the ML with oblimin rotation method ( $\delta = 0$ ). The results suggested three factors and the factor structure was well defined (see Table 10). This model was called HMS-HE Model 2.

Similarly, to further confirm the number of factors, four factor determination tests were conducted, including using eigenvalue greater than 1 as the extraction criteria, scree test, Minimum Partial Average test (MAP; Velicer, 1976), and Parallel Analysis (PA; Horn, 1965; Cota, Longman, Holden, & Rekken, 1993). Using eigenvalue greater than 1 as the extraction criteria, when ML was applied with rotation of oblimin ( $\delta = 0$ ), two factors were identified. The scree test indicated one factor (see Figure 16). The MAP test indicated two factors. However, when two factors were extracted, the structure pattern was not clear enough. The PA test suggested one factor in the data as only the first eigenvalue from the original data was greater than the 95<sup>th</sup> percentile of the random eigenvalue (see Table 11). The one factor might yield meaningful information, so the one factor model, called HMS-HE model 2\*, was tested in Study 2. These different tests have

Table 10

*Pattern Coefficients (PC) and Structure Coefficients (SC) Obtained from Maximum Likelihood Solution with Oblimin Rotation (N = 259) for the HMS-HE Model 2*

	Factor 1 <sup>c</sup>		Factor 2		Factor 3	
	PC	SC	PC	SC	PC	SC
HI6 <sup>a</sup>	0.85	0.86				
HI4	0.84	0.82				
HI7	0.77	0.76				
HI2	0.65	0.71				
HMT6	0.49	0.74				
HMT1	0.40	0.69			0.34	
AIM4			0.82	0.81		
AIM5			0.73	0.78		
AIM1			0.65	0.68		
PM4					0.82	0.81
PM5					0.64	0.73
PM3					0.61	0.70
Label <sup>b</sup>	Health motivation tendency and Health intention		Action initiation motivation		Persistency Motivation	

*Note.* <sup>a</sup> Letters indicate the domain originally assigned in the HMS. HMT = Health Motivation Tendency, HI = Health Intention, AIM = Action Initiation Motivation, and PM = Persistence Motivation. Loadings larger than .30 are reported. <sup>b</sup> Label indicates the suggested factor name. <sup>c</sup>Eigenvalues after rotation for the four factors from the left to the right were 4.36, 5.29, 4.67, and 5.42 respectively, with the total variance of 71.63%.

distinct implication of the number of the factors that underlie the data. By comparison among these different tests, the four-factor solution was retained because it is most meaningful.

The overall internal consistency alpha for the scores of the HMS-HE model 2 was .91. The alphas for the scores of the four subscales of health motivational tendency, health intention, health action initiation motivation, and persistence motivation were .84, .86, .80, and .79 respectively.

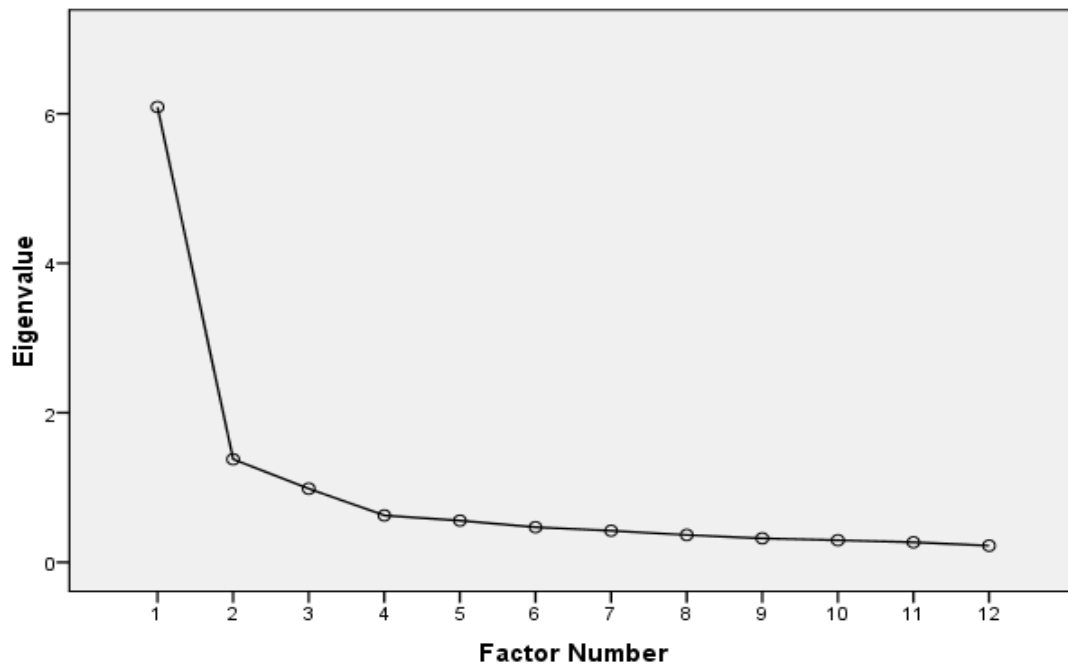

Figure 16. The Scree Plot of the HMS-HE Model 2.



Table 11

*The 95<sup>th</sup> Percentile of the Random Eigenvalues and Eigenvalues from the Original Data  
(for the HMS-HE Model 2)*

Root	95 <sup>th</sup> Percentile Random Eigenvalue	Eigenvalue from the Original Data
1	1.44	5.65
2	1.34	0.90
3	1.24	0.51
4	1.17	0.21
5	...	...

To retain more items and try to see a clearer picture of the model, the cutting criterion was extended to loadings no less than .30. Fourteen items were deleted due to their miss-loadings or their loadings on more than one factor. The deleted items were PM2, AIM6, HI1, PM7, AIM7, HMT4, HMT5, AIM2, PM3, PM6, HMT2, HI5, PM1, and HMT7. After deleting these items, the same extraction and rotation factoring methods were applied to the remaining items; that is, using the ML with oblimin rotation method (delta = 0). The results suggested the factor structure of the reduced Health motivation scale in physical activities was well defined for almost all the items, except for HMT3. Item HMT3 loaded on two non-designated factor – health intention and action initiation motivation (-.35 vs. .35) (see Table 12). In addition, item HMT6 and AIM3 loaded on more than one factor. These items are subjected to further investigate in future use.

Table 12

*Pattern Coefficients (PC) and Structure Coefficients (SC) Obtained from Maximum Likelihood Solution with Oblimin Rotation (N = 259) for the HMS-HE Model 3*

	Factor 1 <sup>c</sup>		Factor 2		Factor 3		Factor 4	
	PC	SC	PC	SC	PC	SC	PC	SC
HMT1 <sup>a</sup>	0.71	0.87						
HMT6	0.41	0.70	-0.40					
HMT8	0.33	0.58					0.46	
HMT3		0.60	-0.35		0.35			
HI4			-0.81	-0.83				
HI6			-0.76	-0.84				
HI7			-0.70	-0.75				
HI2			-0.63	-0.72				
AIM4					0.80	0.81		
AIM5					0.71	0.78		
AIM1					0.61	0.68		
AIM3					0.31	0.60	0.51	
PM5							0.66	0.73
PM4							0.64	0.73
PM8							0.63	0.76
PM3							0.62	0.76
Label <sup>b</sup>	Health motivation tendency		Health intention		Action initiation motivation		Persistence motivation	

*Note.* <sup>a</sup> Letters in front of the item number indicate the domain originally assigned in the HMS. HMT = Health Motivation Tendency, HI = Health Intention, AIM = Action Initiation Motivation, and PM = Persistence Motivation. Loadings larger than .30 are reported. <sup>b</sup> Label indicates the suggested factor name. <sup>c</sup>Eigenvalues after rotation for the four factors from the left to the right were 4.36, 5.29, 4.67, and 5.42 respectively. The total variance explained by the four factors was 71.63%.

Table 13

*The 95<sup>th</sup> Percentile of the Random Eigenvalues and Eigenvalues from the Original Data (for the HMS-HE Model 3)*

Root	95 <sup>th</sup> Percentile Random Eigenvalue	Eigenvalue from the Original Data
1	1.55	7.58
2	1.40	1.15
3	1.31	0.74
4	1.26	0.27
5	...	...

Again three different tests were conducted to further confirm the number of factors, including using eigenvalue greater than 1 as the extraction criteria, scree test, Minimum Partial Average test (MAP; Velicer, 1976), and Parallel Analysis (PA; Horn, 1965; Cota, Longman, Holden, & Rekken, 1993). Using eigenvalue greater than 1 as the extraction criteria, when ML was applied with rotation of oblimin ( $\delta = 0$ ), three factors were identified. However, the scree test indicated one factor (see Figure 17). The MAP test indicated three factors. Further, the PA test suggested one factor in the data as only the first eigenvalue from the original data was greater than the 95<sup>th</sup> percentile of the random eigenvalue (see Table 13). The one factor might yield meaningful information, so the one factor model, called HMS-HE model 3\*, was tested in Study 2. These different tests have distinct implication of the number of the factors that underlie the data. However, the four-factor solution was retained because it was theoretically meaningful.

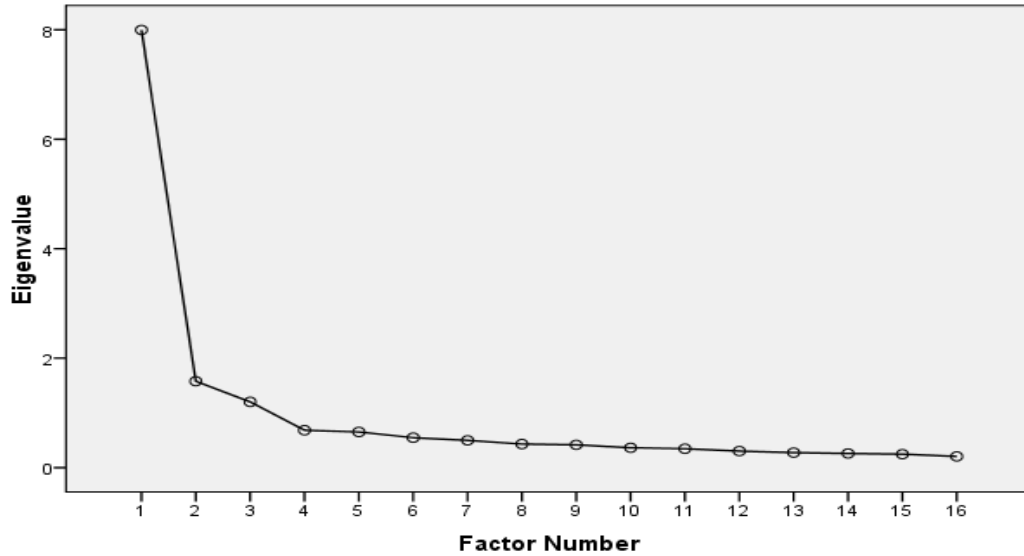

Figure 17. The Scree Plot of the HMS-HE Model 3.

The overall internal consistency alpha for the scores of the HMS-HE model 3 was .93. The alphas for the scores of the four subscales of health motivational tendency, health intention, health action initiation motivation, and persistence motivation were .84, .86, .81, and .83 respectively.

*Correlations between the Scores of Three Scales*

To examine the relationships between the HMS-HE and HSDI and SMI, correlation analyses (Pearson  $r$ ) were conducted between the scores of these scales. It was found that the scores of the HMS-HE Model 1 did not correlate with those of the HSDI and SMI, with correlations of .08 and .03 respectively. The scores of the HMS-HE Model 2 were

not associated with the HSDI and SMI either, with correlations of .07 and .00 respectively. The scores of the HMS-HE Model 3 were not associated with the HSDI and SMI either, with correlations of .07 and .01 respectively.

To further investigate the relationships between HMS-HE and HSDI and SMI, simple scatter plots were drawn between these scales. As can be seen from the following figures (Figure 18-Figure 23), there were no apparent quadratic relationships between HMS-HE (including all three models) and HSDI, and between HMS-HE (including all three models) and SMI.

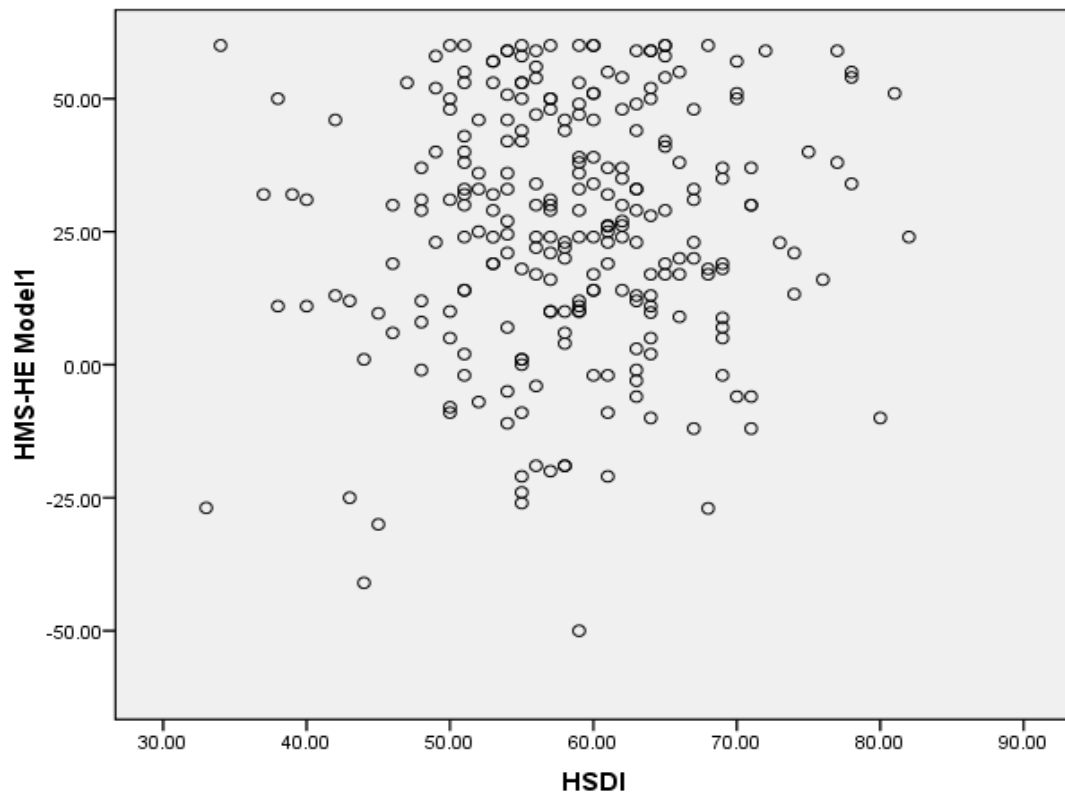

Figure 18. The Scatter Plot of the HMS-HE Model 1 and the HSDI.

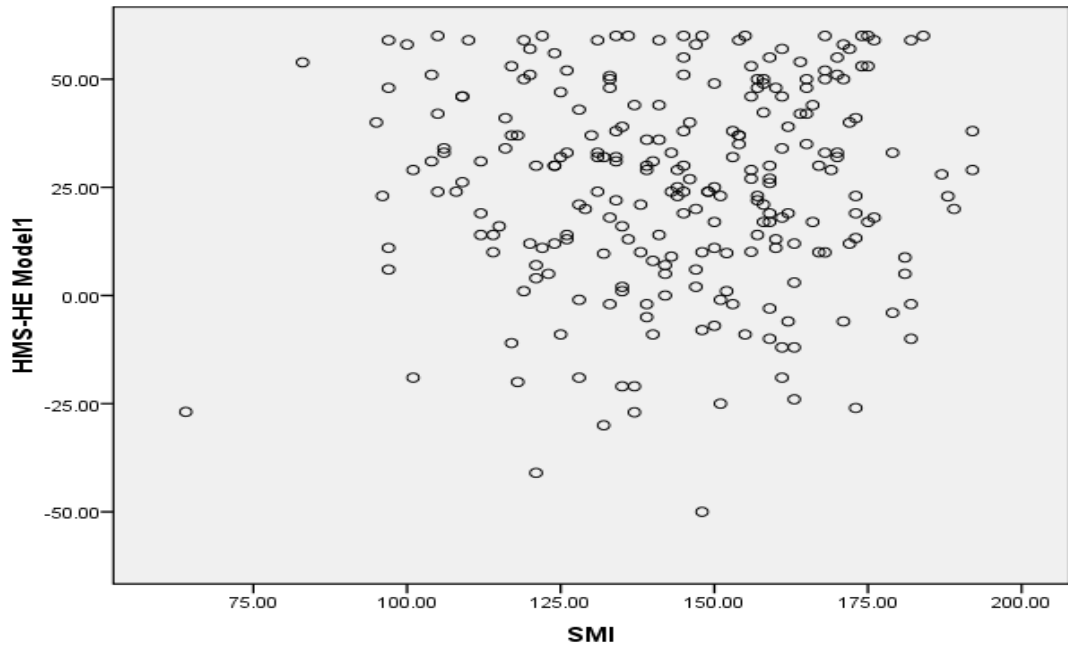

Figure 19. The Scatter Plot of the HMS-HE Model 1 and the SMI.

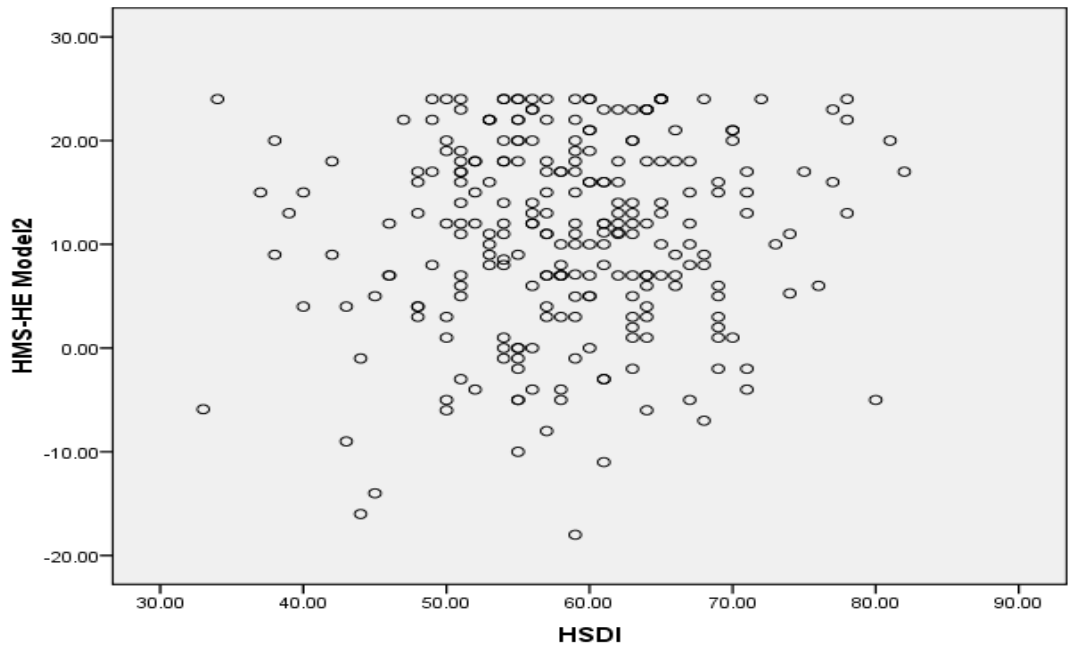

Figure 20. The Scatter Plot of the HMS-HE Model 2 and the HSDI.

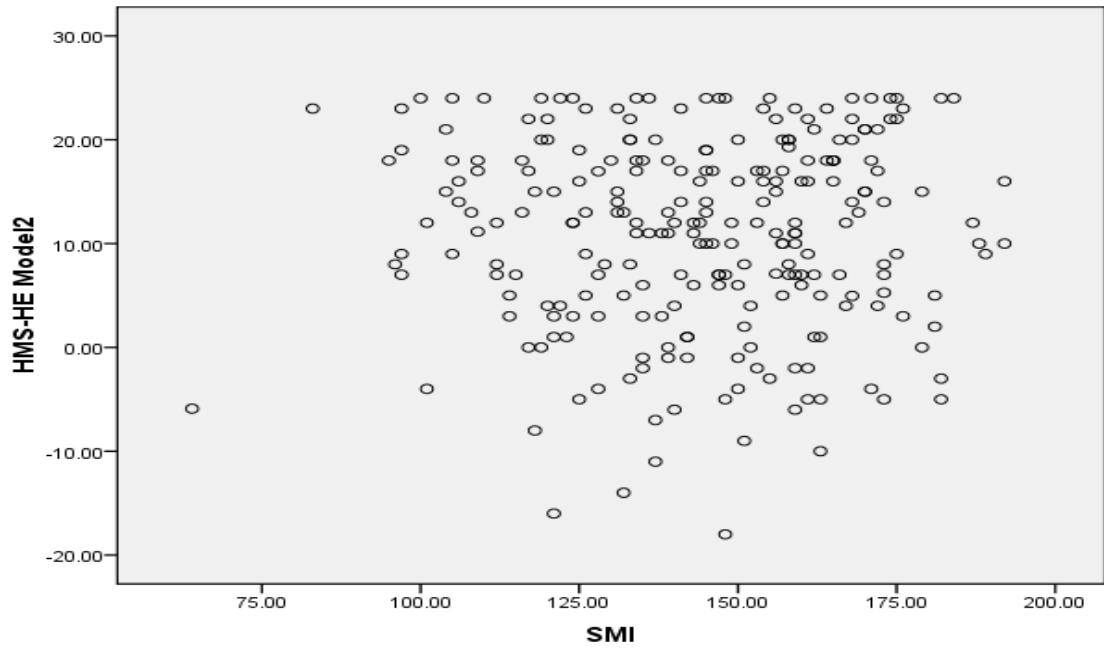

Figure 21. The Scatter Plot of the HMS-HE Model 2 and the SMI.

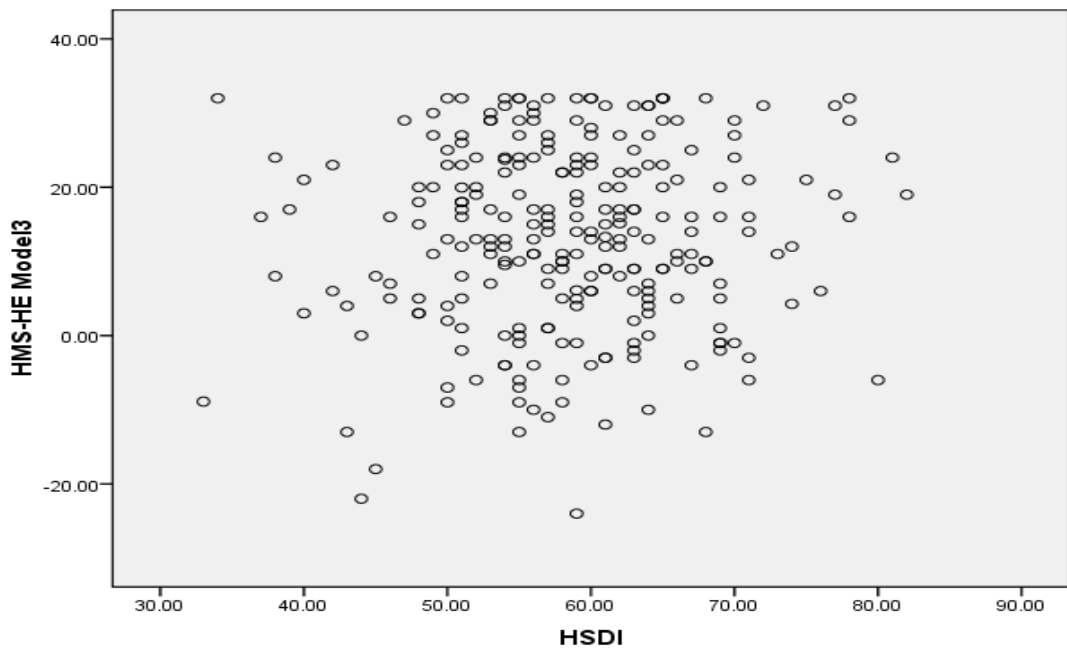
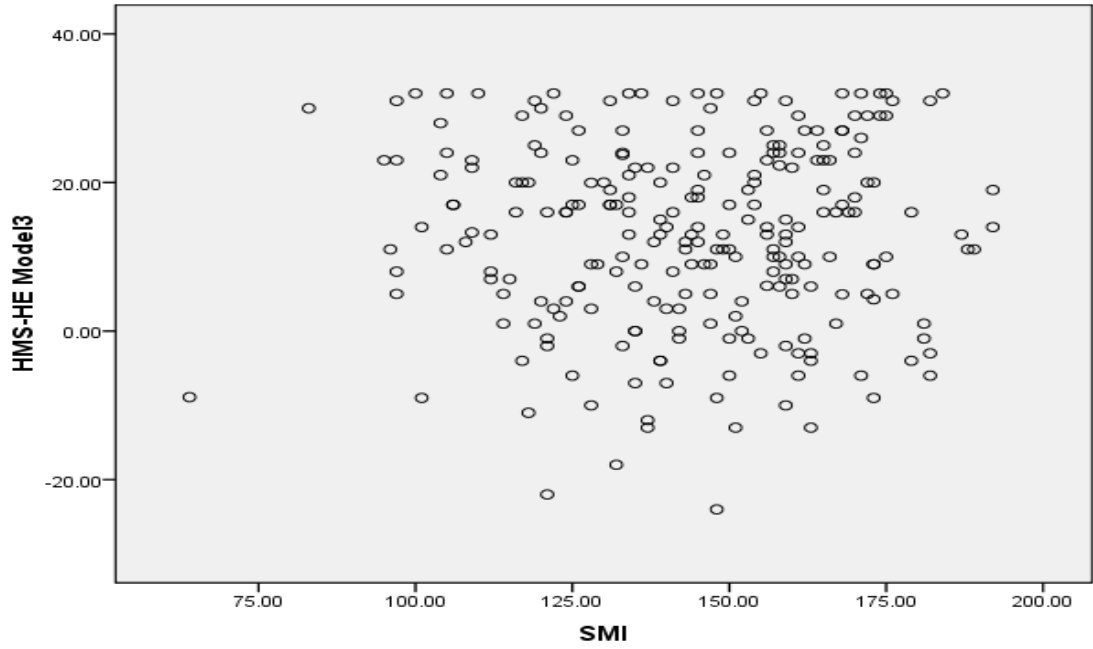

Figure 22. The Scatter Plot of the HMS-HE Model 3 and the HSDI.



*Figure 23.* The Scatter Plot of the HMS-HE Model 3 and the SMI.



## CHAPTER 5

### STUDY 2

#### Purposes

The main purposes of Study 2 were to further validate the quality of the two health motivation scales proposed in Study 1 and to examine how well health motivation predicted health behaviors compared to several other factors such as health self-efficacy and health value. Previous studies mainly focused on disease related or disease prevention behaviors. However, in the present study, health behaviors related to physical activity and healthy food choice were studied in this study because it is believed that daily activities are very critical to individuals' health as well. Confirmatory Factor Analyses were administered to test the construct validity of the scores obtained by the two scales. Figure 24 is the general measurement model of health motivation. Multiple regression analyses were conducted to investigate the causal relationships among variables. The dependent variables involved in the present study were physical activities and healthy food choice. The independent variables involved were Body Mass Index (BMI), health value, health self-efficacy, and health motivation.

#### Methods

##### *Participants*

Two hundred and eighty nine undergraduate volunteers were recruited from the Subject pool of Psychology Department at University of Nevada, Las Vegas. Two cases were excluded from further analysis because of their ages were on the extreme end, with one 53 years old and the other one 75 years old. Among the rest, one hundred and eleven

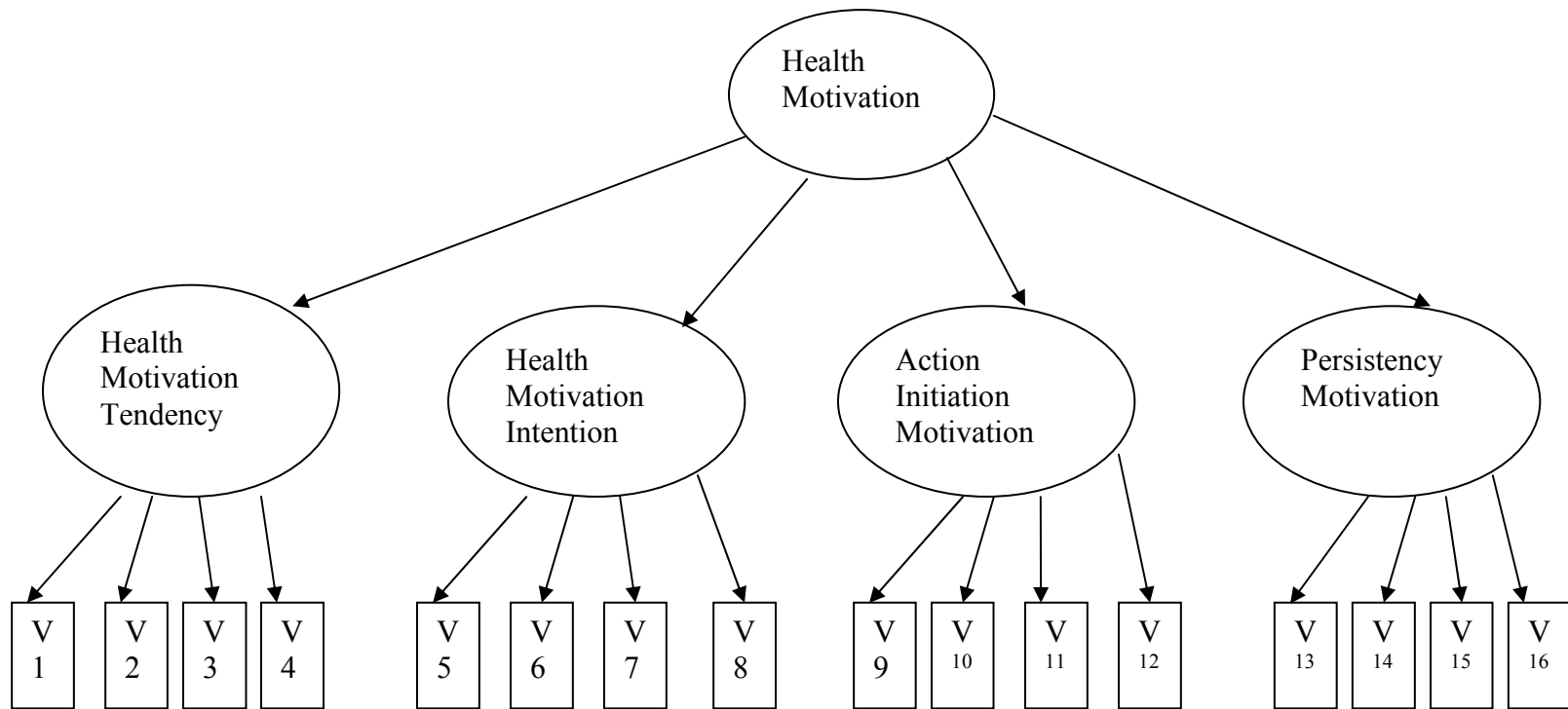

Figure 24. A Proposed Model of Health Motivation-Measurement Model.

were males; one hundred and seventy were females; six were not identified. They aged from 18 to 45, with the mean age of 20.98 ( $SD = 4.30$ ). Two extreme cases were deleted because the participants were over 50 years old. Their weight ranged from 85 to 450 pounds, with the mean weight of 150.67 pounds ( $SD = 39.78$ ), with the height ranging from 58 to 76 inches ( $M = 66.75$  inches,  $SD = 3.91$ ). The minimum BMI was 16.50 and the maximum was 62.76, with a mean of 23.63 ( $SD = 5.11$ ). The BMI was calculated using the formula of  $BMI = (\text{Weight in Pounds} \times 703) / (\text{Height in inches}) \times (\text{Height in inches})$ . Most of the participants (41.8%) were White; 9.8% were African American, 12.9% were Hispanic; 23% were Native American; 9.1% were Asian; and 3.5% were not-identified or other. Participants were asked to rate their health on a 7-point scale, ranging from “1” (Not healthy at all) to “7” (Extremely healthy). Their health rating ranged from 2 to 7, with a mean of 5.46 ( $SD = 0.98$ ).

### *Measures*

#### *Health Behavior Measures*

##### *The Global Physical Activity Questionnaire*

To measure physical activities, the second version of the World Health Organization (WHO) Global Physical Activity Questionnaire (GPAQ) (Armstrong & Bull, 2006) was selected. It was chosen because it is a comprehensive scale that measures physical activities in most related domains. The GPAQ consists of three domains: work, transport, and recreation, with 16 items in total (Armstrong & Bull, 2006). The scores collected using at different times exhibited desirable test-retest reliabilities, with  $r = .67 - .81$  for 3- to 7-day time gap (Armstrong & Bull, 2006). Armstrong and Bull (2006) also reported

the good criterion validity of the physical activities obtained by the GPAQ. Its corresponding coding protocol was applied to code the data collected in this study. The total physical activity scores computed based upon the procedure provided in the coding protocol served as the dependent variable of physical activity in the present study.

#### *The Adolescent Food Habits Checklist*

To measure eating behaviors, the Adolescent Food Habits Checklist (AFHC; Johnson, Wardle, & Griffith, 2002) was selected (see Appendix B). This scale was chosen because the AFHC was developed for adolescence population and my participants were undergraduate students at a university most of whom were adolescent. This scale was original designed to assess adolescences' healthy eating behavior towards a situation in which they are likely to have personal control (Johnson, et al., 2002). Specifically, it emphasizes the areas of fat intake, fruit and vegetable intake. There are 23 items in total. Participants respond to the questions with "True," "False," or a third option that indicates "not applicable" (Johnson, et al., 2002). The reported internal consistency of the AFHC was .83, and the reported test-retest reliability with an interval of two weeks was .90 (Johnson, et al., 2002). The data collected were coded according to the coding protocol John and his colleagues provided. The final score served as the dependent variable of healthy eating in this study.

#### *Health Motivation Scales*

##### *The Revised Striving Assessment*

The revised Striving Assessment (SA-r) was one of the health motivation scales. Original Striving Assessment was developed by Emmons (1986) to study personal

strivings and related issues, for example, the relationships between personal strivings and psychological well-being. In later research, this approach was used to measure motivation (e.g., King, 1995). The original Striving Assessment consists of a number of identical items of “I typically try to \_\_\_\_\_.” A coding schema was developed to code these personal strivings (Emmons, 1999). In this study, a revised Striving Assessment (SA-r) will be used. The SA-r consists of 12 identical items of “I typically try to because \_\_\_\_\_.” The second part was added because it was found that sometimes it was difficult to code these strivings without stating the reason in previous research. For example, a personal striving -- “I typically try to get good grades” would be coded as Achievement motivation in a common sense. However, this coding may not always be accurate because this personal striving can be coded as Affiliation motivation if it is phrased as “I typically try to get good grades *because I want to please my parents.*” Therefore, the revised version of Striving Assessment was developed and used in this study (see Appendix C). In this study, participants were asked to list 12 personal strivings. This number is arbitrary.

The coding of the personal strivings was based upon the criteria for Health motivation proposed by Xu and her colleagues (Xu, et al., 2008). Their operation definition of Health motivation was “a desire to exercise; to eat well; to live in a healthy environment; and to be calm and tranquil while sleeping well and avoiding stress” (Xu, et al., 2008). Specific to this study, the criteria of “a desire to exercise; to eat well; to live in a healthy environment” were adopted to code Health motivation in the present study.

### *The Motivation Ranking Scale*

The motivation ranking scale was another health motivation scale. It is believed that individuals' behaviors are determined by their motivation. If individuals are motivated by several different motives which can result in different behaviors, then the important level of the motives matter a lot. Therefore, the motivation ranking scale (see Appendix C) was used to assess how important the Health motivation was to the participants. The definitions of the listed motivation were proposed by Xu (Xu, 2006).

### *The HMS-PA and HMS-HE*

The newly developed two health motivation scales – the Health Motivation Scales in Physical Activities and Healthy Food Choice developed in Study 1 were the other two health motivation scales used in this study (see Appendix A).

### *Scales of Health Value*

#### *The Four-item Scale*

In this study, a four-item health value scale developed by Lau, Hartman, and Ware (1986) was conducted to measure participants' health value. This scale is a 7-point Likert scale, ranging from 1 "strongly disagree" to 7 "strongly agree." The four items are: (1) If you don't have your health you don't have anything; (2) There are many things I care about more than my health; (3) Good health is of only minor importance in a happy life; and (4) There is nothing more important than good health. The reported internal consistency of this scale was .67, and the test-retest reliability was .78 (Lau, Hartman, & Ware, 1986).

### *The Health Value Ranking Scale*

The second approach used to measure health value was Rokeach's (1973) health value survey. This survey asks participants to rank 18 terminal values in terms of their importance. The variation of this survey has been used to measure health value by a number of researchers; that is, including health on the list (Norman & Bennett, 1996). In a later version, Rokeach replaced one of the values – Happiness (contentedness) with “Health (physical and mental well-being).” This later version (see Appendix D) was administered in this study.

### *The Scale of Health Self-efficacy*

The Health Self-efficacy Scale developed by Becker, Stuijbergen, Oh, and Hall (1993) was used in the present study. This scale consists of four subscales: Exercise, Nutrition, Responsible Health Practices, and Psychological Well-being. For the purpose of this study, only Exercise and Nutrition subscales were chosen and conducted. It is a 5-point scale ranging from 0-not at all to 4-completely, and it has 28 items (see Appendix E). An item example of Exercise is “Do exercises that are good for me.” An example of Nutrition is “Eat a balanced diet.” The reported test-retest reliabilities of the subscales of Nutrition and Exercise were .70 and .63 respectively, and the internal consistencies were .81 and .89 (Becker, et al., 1993).

### *Procedure*

The proposal of this study was approved by the IRB of the University of Nevada, Las Vegas. To minimize the order effect, scales were presented in two orders, with odd experiment number for HMS, SA-r, the motivation ranking scale, GPAQ, AFHC, health

value scales (four-item scale first, then the ranking scale), and health self-efficacy scale and with even experiment number for two health value scales (four-item scale first, then the ranking scale), health self-efficacy scale, GPAQ, AFHC, HMS, SA-r, and the motivation ranking scale. Participants came to the lab in a small group and were assigned an experiment number randomly. Then, they were informed with the purposes of this study before they consented participating in this study. After that, they consented and completed all the scales. They were debriefed when they filled out all the scales.

## Results

### *Construct Validation*

To test the construct validity of scores obtained using the two health motivation scales (HMS-PA and HMS-HE), higher order Confirmatory Factor Analyses were conducted. EQS 6.1 was used to perform the CFA analyses.

#### *Confirmatory Factor Analysis for the HMS-PA*

##### *Confirmatory Factor Analysis for the HMS-PA Model 1*

*First-order factor model.* This first-order model specified four factors (health motivation tendencies, health intention, action initiation, and persistency motivation), with 6-8 indicators for each factor. Each indicator was constrained to load just on the factor it was designated to measure. All the factor covariances were free to be estimated. Error terms that were associated with each indicator were uncorrelated. The indices were:  $\chi^2$  (399,  $N = 228$ ) = 1256.723,  $p < .001$ , CFI = .797, GFI = .688, NFI = .731, NNFI = .779, Standard RMR = .071, RMSEA = .097 (CI = .091, .103). The loadings ranged from .46



to .80 and the *R*-squared ranged from .22 to .68. Figure 25 presents the first-order health motivation model, along with the estimates of factor loadings and error terms.

The Wald test and LM test were conducted to examine the parameters and see if any parameters should be added or dropped. As indicated by Wald test, all the free parameters were reasonable and statistically significant. However, a few factor loading parameters were suggested to be added by the LM test. Nevertheless, no changes were applied to the original first-order model because the scale will be revised and tested again in the next section.

The correlations among the four first-order factors are presented in Table 14. These correlations were very high, ranging from .80 to 1.01. The high correlations indicated that they might measure the same things or there might be a higher-order factor that can explain such strong relationships among these four factors.

Table 14

*Correlations between the First-order Factors in the HMS-PA Model 1*

	Health Motivation Tendency	Health Intention	Action Initiation	Persistency Motivation
Health Motivation Tendency	1.00			
Health Intention	1.01	1.00		
Action Initiation	.94	.91	1.00	
Persistency Motivation	.90	.80	.85	1.00

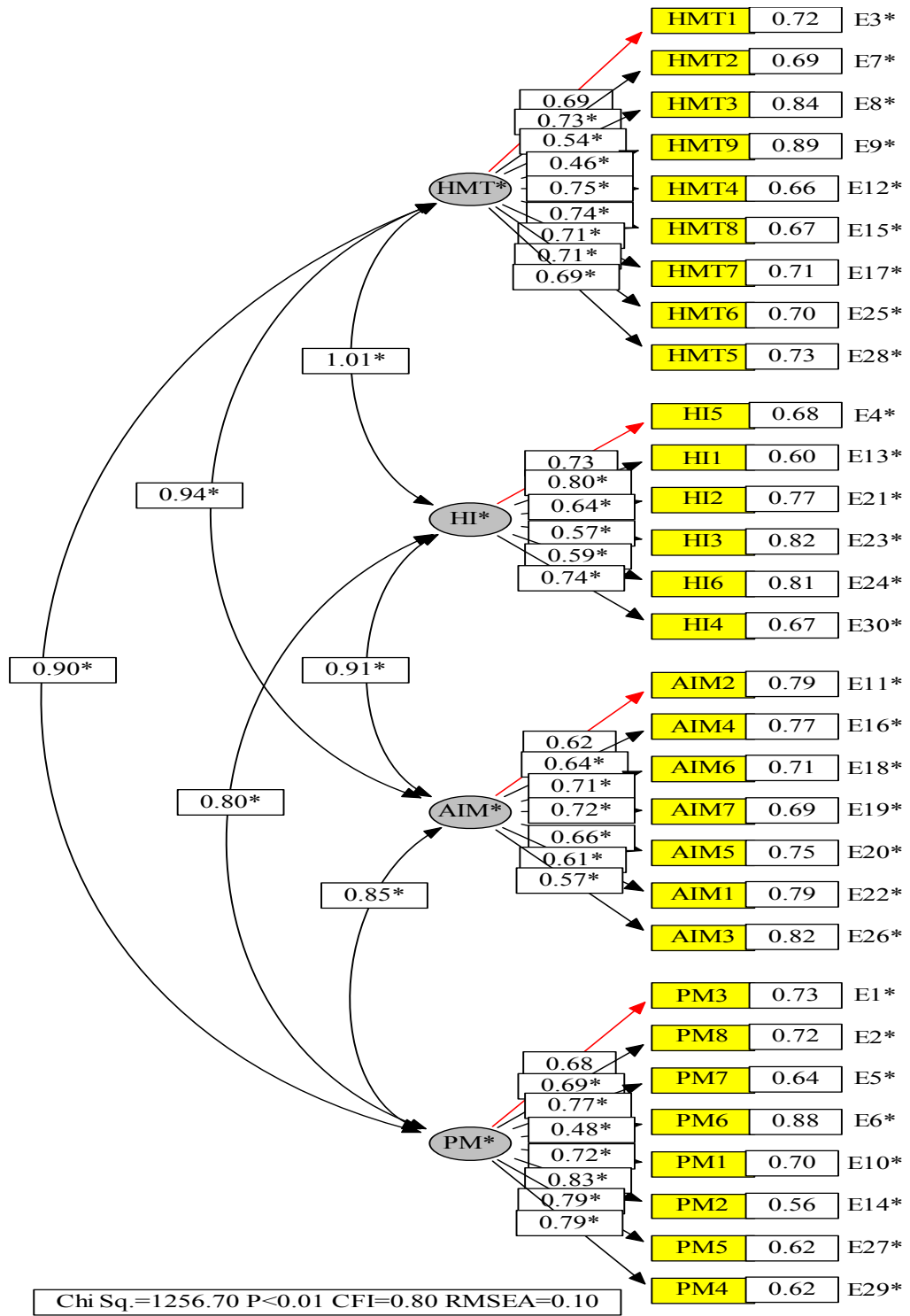

Figure 25. HMS-PA Model 1 1<sup>st</sup> Order CFA.

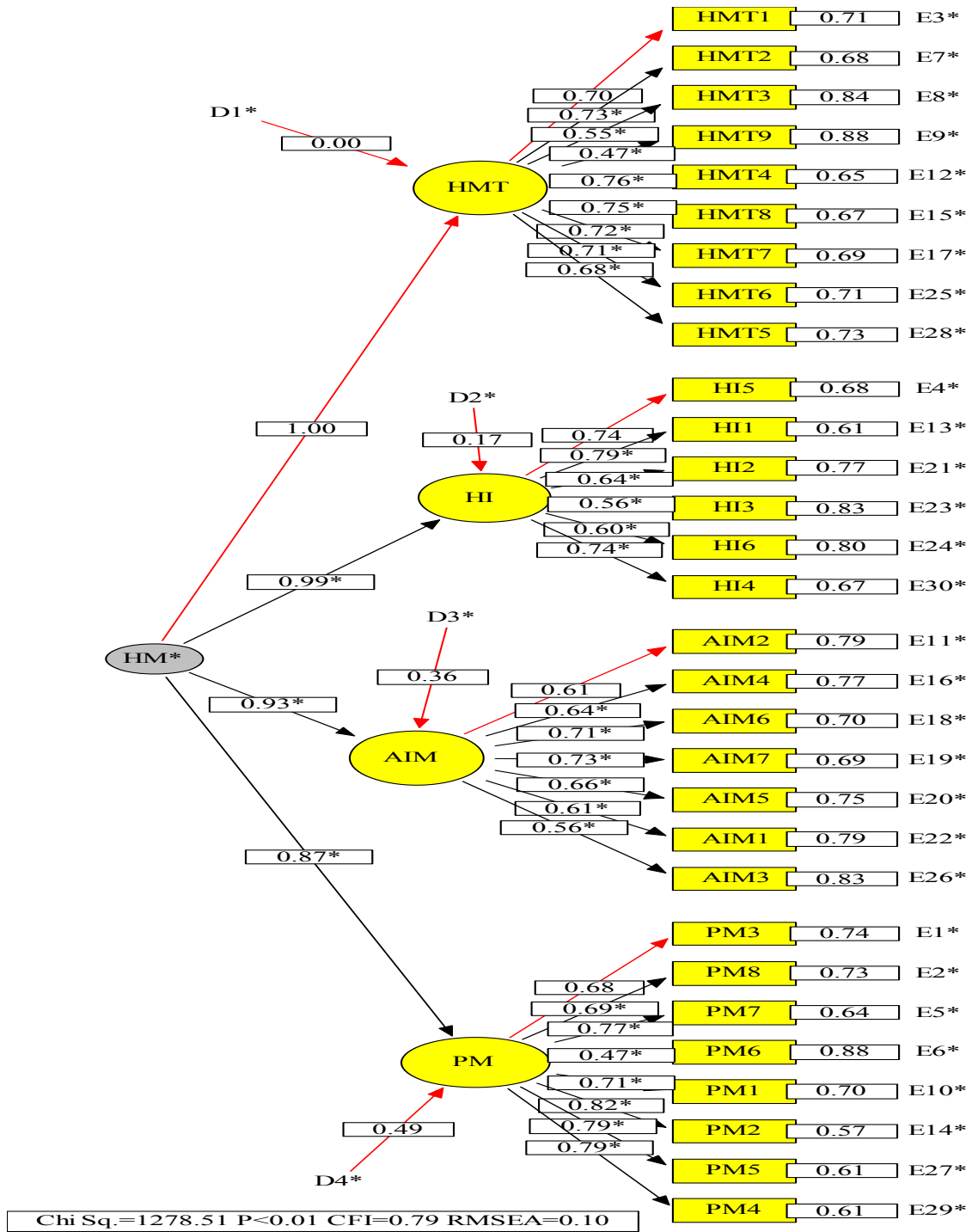

Figure 26. HMS-PA Model 1 2<sup>nd</sup> Order CFA.

*Second-order factor model.* The second-order factor model included only one factor, health motivation, in place of first-order factor covariances. The indices were:  $\chi^2$  (401,  $N = 228$ ) = 1278.51,  $p < .001$ , CFI = .793, GFI = .684, NFI = .726, NNFI = .775, Standard RMR = .073, RMSEA = .098 (CI = .092, .104). The loadings ranged from .47 to 1.00 and the  $R$ -squared ranged from .22 to 1.00. Figure 26 presents the second-order health motivation model in physical activities with the full length scale. The estimates of factor loadings and disturbance terms were along with the figure. The Wald test indicated that disturbance variance of action initiation was not significant. Similar suggestions as that of the first-order factor model examination were made by the LM test.

*Confirmatory factor analysis for the HMS-PA Model 1\*.* This model specified one factor, with 30 indicators in total. Error terms which were associated with each indicator were uncorrelated. The indices were:  $\chi^2$  (405,  $N = 228$ ) = 1425.983,  $p < .001$ , CFI = .759, GFI = .655, NFI = .695, NNFI = .741, Standard RMR = .075, RMSEA = .105 (CI = .099, .111). The loadings ranged from .45 to .77 and the  $R$ -squared ranged from .21 to .60.

The Wald test and LM test were conducted to examine the parameters and see if any parameters should be added or dropped. As indicated by Wald test, all the free parameters were reasonable and statistically significant. No parameters were suggested to be added by the LM test.

#### *Confirmatory Factor Analysis for the HMS-PA Model 2*

*First-order factor model.* This first-order model specified four factors (health motivation tendencies, health intention, action initiation, and persistency motivation),

with 2 to 5 indicators for each factor. Each indicator was constrained to load just on the factor it was designated to measure. All the factor covariances were free to be estimated. Error terms which were associated with each indicator were uncorrelated. The indices were:  $\chi^2 (59, N = 234) = 365.56, p < .001$ , CFI = .925, GFI = .892, NFI = .892, NNFI = .901, Standard RMR = .056, RMSEA = .090 (CI = .074, .106). The loadings ranged from .53 to .88 and the *R*-squared ranged from .28 to .78. Figure 27 presents this first-order health motivation model in physical activities with shortened scale. The estimates of factor loadings and error terms were along with the figure.

All free parameters were reasonable and statistically significant by the Wald test. However, the LM test suggested a few parameters to be added. For example the top two suggested parameters were a parameter between HI4 and persistency motivation and a parameter between PM2 and health motivation tendency. Although the LM test indicated that these two were statistically significant, when these two parameters were added, no significant improvement on the model fit was found. Therefore, no changes were made to this model.

Factor correlations among the four factors are shown in Table 15. The correlations ranged from .56 to .75, indicating that a higher order factor existed and that factor explained the strong relationships among the four factors.

*Second-order factor model.* The second-order factor model included only one factor, health motivation, in place of first-order factor covariances. The indices were:  $\chi^2 (61, N = 234) = 176.715, p < .001$ , CFI = .923, GFI = .889, NFI = .888, NNFI = .901, Standard RMR = .058, RMSEA = .090 (CI = .075, .106). The loadings ranged from .54 to .88 and

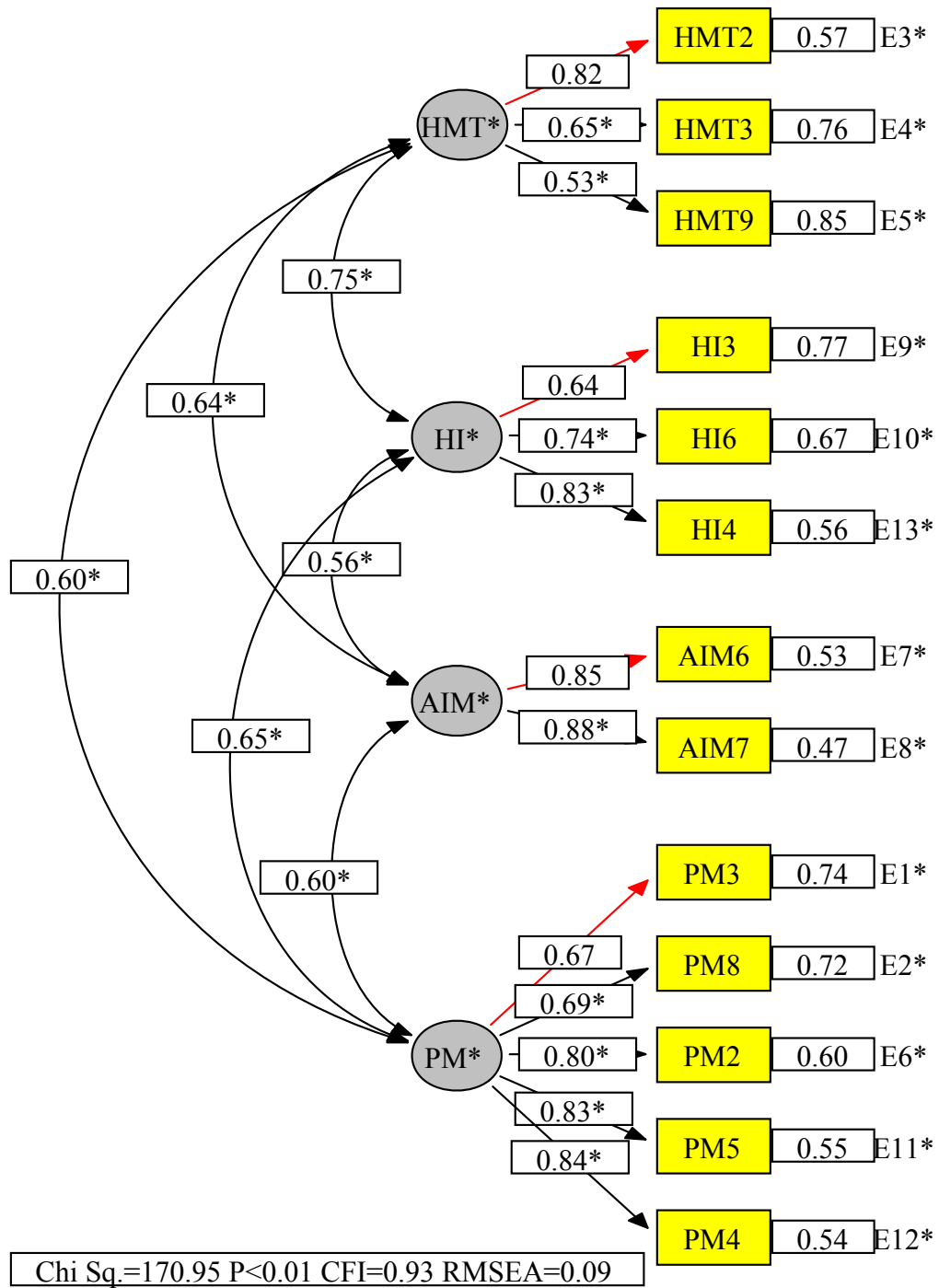

Figure 27. HMS-PA Model 2 1<sup>st</sup> Order CFA.

Table 15

*Correlations between the First-order Factors in the HMS-PA Model 2*

	Health Motivation Tendency	Health Intention	Action Initiation	Persistency Motivation
Health Motivation Tendency	1.00			
Health Intention	.75	1.00		
Action Initiation	.64	.56	1.00	
Persistency Motivation	.61	.65	.60	1.00

the *R*-squared ranged from .29 to .78. Figure 28 presents this second-order health motivation model in physical activities with shortened scale. The estimates of factor loadings and disturbance terms were along with the figure. The Wald test for the second-order model indicated that none of the free parameters needed to be dropped. The LM test also suggested that to add the parameters between HI4 and persistency motivation and PM2 and healthy motivation tendency. However, no significant changes were found when these parameters were added.

*Confirmatory factor analysis for the HMS-PA Model 2\**. This model specified one factor, with 13 indicators in total. Error terms which were associated with each indicator were uncorrelated. The indices were:  $\chi^2$  (65,  $N = 234$ ) = 472.731,  $p < .001$ , CFI = .728, GFI = .731, NFI = .700, NNFI = .673, Standard RMR = .097, RMSEA = .164 (CI = .150, .178). The loadings ranged from .45 to .78 and the *R*-squared ranged from .20

to .61. No parameters were suggested to be added or dropped by the Wald and LM test.

*Confirmatory factor analysis for the HMS-PA Model 2\**. This model specified one factor, with 13 indicators in total. Error terms which were associated with each indicator were uncorrelated. The indices were:  $\chi^2$  (65,  $N = 234$ ) = 472.731,  $p < .001$ , CFI = .728, GFI = .731, NFI = .700, NNFI = .673, Standard RMR = .097, RMSEA = .164 (CI = .150, .178). The loadings ranged from .45 to .78 and the R-squared ranged from .20 to .61. No parameters were suggested to be added or dropped by the Wald and LM test.

#### *Confirmatory Factor Analysis for the HMS-PA Model 3*

*First-order factor model*. This first-order model specified four factors (health motivation tendencies, health intention, action initiation, and persistency motivation), with 4 or 5 indicators for each factor. Each indicator was constrained to load just on the factor it was designated to measure. All the factor covariances were free to be estimated. Error terms which were associated with each indicator were uncorrelated. The indices were:  $\chi^2$  (113,  $N = 233$ ) = 365.56,  $p < .001$ , CFI = .875, GFI = .841, NFI = .831, NNFI = .850, Standard RMR = .063, RMSEA = .098 (CI = .087, .109). The loadings ranged from .52 to .84 and the R-squared ranged from .27 to .70. Figure 29 presents this first-order health motivation model, with the estimates of factor loadings and error terms.

All free parameters were reasonable and statistically significant by the Wald test. However, the LM test suggested to be added a few factor loading parameters. Nevertheless, no changes were made to this model because of the meaningfulness of the model.

Factor correlations among the four factors are shown in Table 16. The correlations



ranged from .64 to .84, indicating that a higher order factor existed and that factor explained the strong relationships among the four factors.

*Second-order factor model.* The second-order factor model included only one factor, health motivation, in place of first-order factor covariances. The indices were:  $\chi^2$  (114,  $N = 233$ ) = 370.48,  $p < .001$ , CFI = .873, GFI = .838, NFI = .829, NNFI = .849, Standard RMR = .063, RMSEA = .098 (CI = .087, .109). The loadings ranged from .52 to .93 and the  $R$ -squared ranged from .27 to .86. Figure 30 presents this second-order health motivation model in the HMS-PA model 3. The estimates of factor loadings and disturbance terms were along with the figure. The Wald test for the second-order model indicated that no parameters needed to be dropped. The LM test suggested that HMT could be explained by AIM4. Therefore, the model was modified by adding a parameter between HMT and AIM4.

Table 16

*Correlations between the First-order Factors in the HMS-PA Model 3*

	Health Motivation Tendency	Health Intention	Action Initiation	Persistency Motivation
Health Motivation Tendency	1.00			
Health Intention	.81	1.00		
Action Initiation	.84	.74	1.00	
Persistency Motivation	.64	.66	.69	1.00

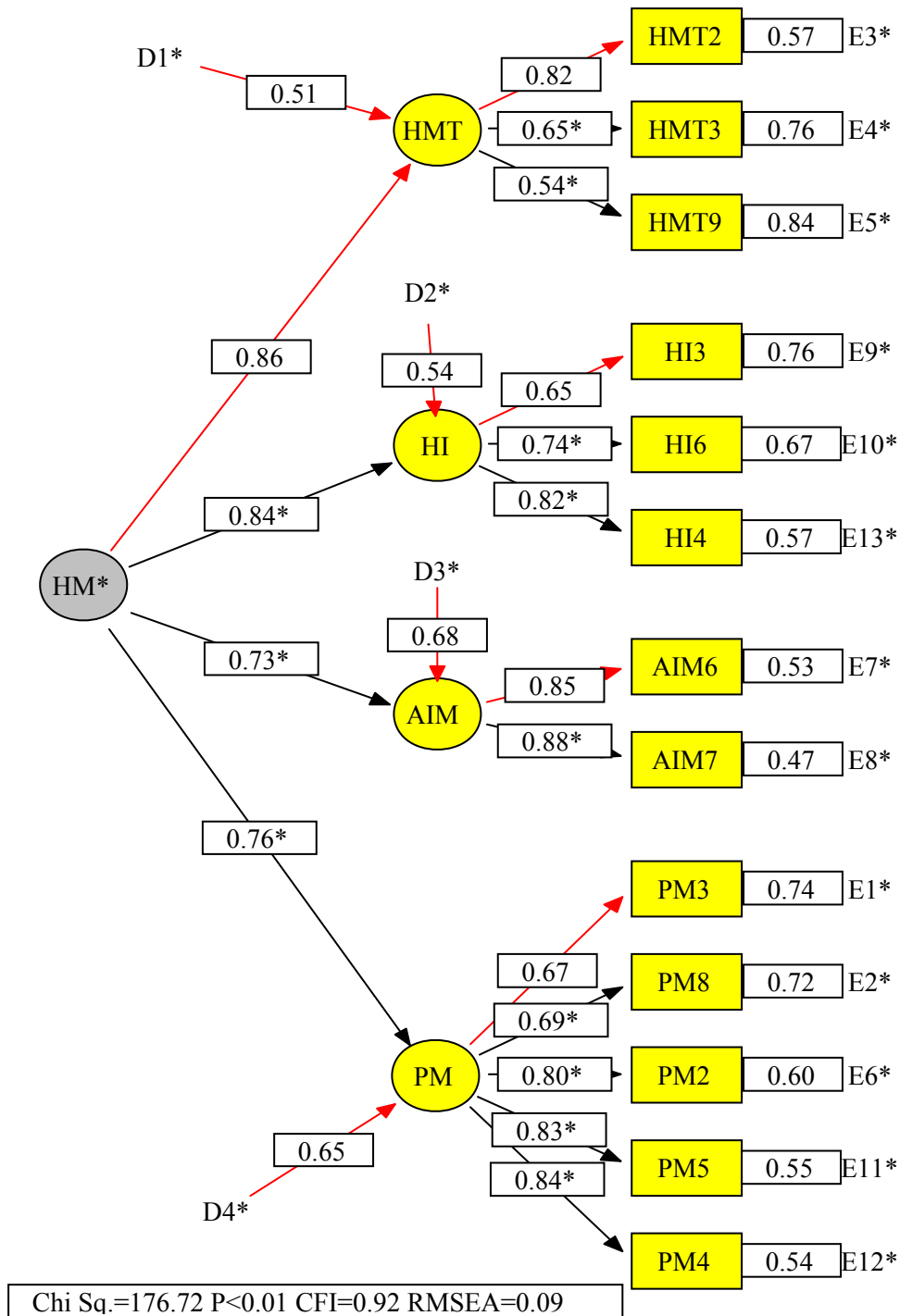

Figure 28. HMS-PA Model 2 2<sup>nd</sup> Order CFA.

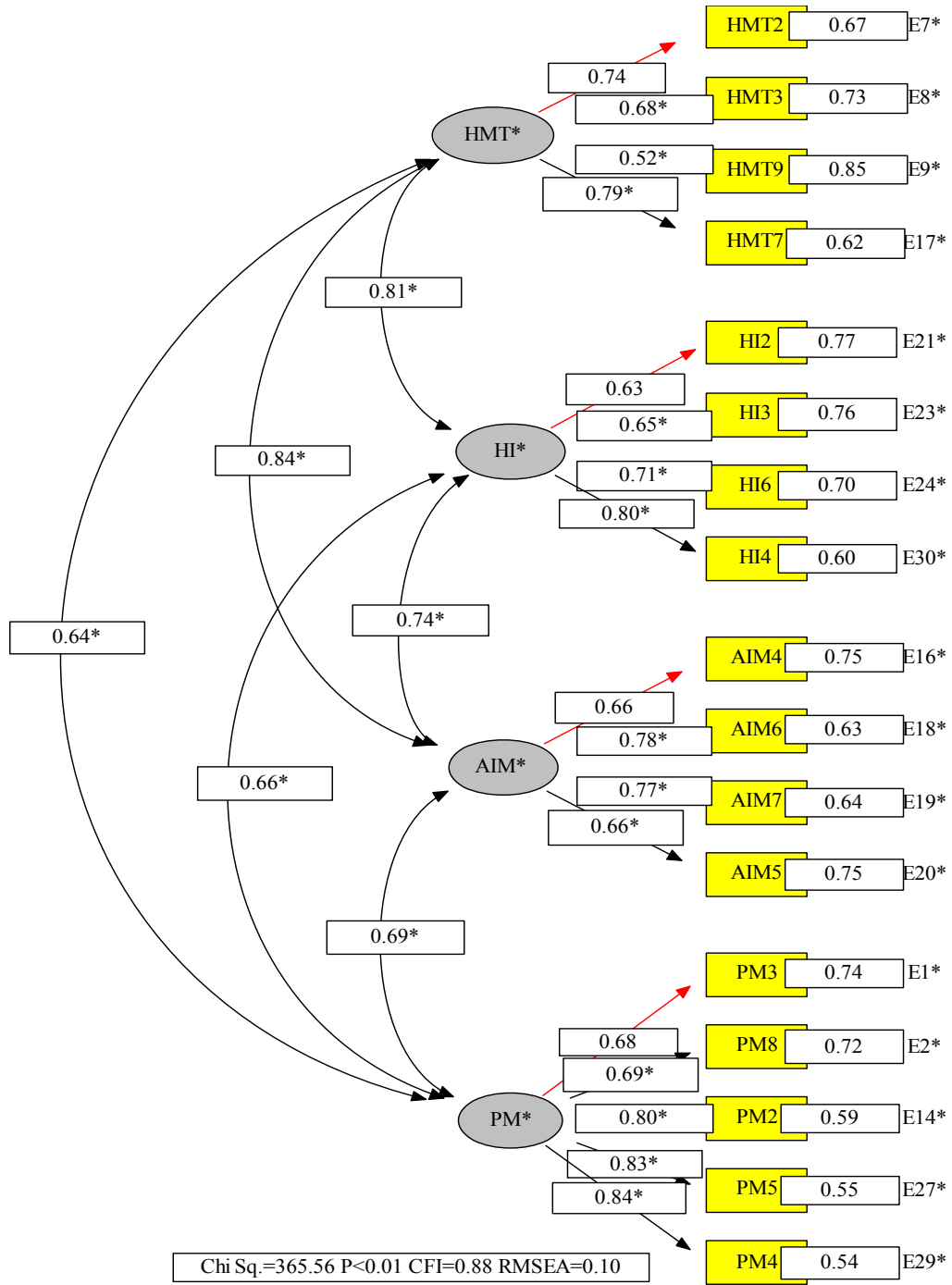

Figure 29. HMS-PA Model 3 1<sup>st</sup> Order CFA.

*Second-order factor model modified.* The indices of this modified model were:  $\chi^2$  (114,  $N = 233$ ) = 345.919,  $p < .001$ , CFI = .886, GFI = .852, NFI = .840, NNFI = .864, Standard RMR = .069, RMSEA = .094 (CI = .082, .105). The loadings ranged from .52 to .91 and the R-squared ranged from .27 to .83. The loading of AIM4 on AIM was .65 in the original model, and the loadings of AIM4 on HMT and AIM was .58 and .12 respectively. The above indices indicated that the modified model did not significantly improve the fit. Therefore, the non-modified second-order factor model was retained because it is simpler than this modified one. Figure 31 presents this modified model. The estimates of factor loadings and disturbance terms were along with the figure.

*Confirmatory factor analysis for the HMS-PA Model 3\*.* This model specified one factor, with 17 indicators in total. Error terms which were associated with each indicator were uncorrelated. The indices were:  $\chi^2$  (119,  $N = 233$ ) = 643.852,  $p < .001$ , CFI = .741, GFI = .724, NFI = .702, NNFI = .704, Standard RMR = .085, RMSEA = .138 (CI = .127, .148). The loadings ranged from .48 to .74 and the R-squared ranged from .23 to .55. All free parameters were reasonable and statistically significant by the Wald test. No parameters were suggested to be added by the LM test.

Although the  $\chi^2$ s of the second-order factor models of all the three HMS-PA models were statistically significant, their normed-chi-squares ( $\chi^2/df$ ) were 3.19 for model 1, 2.90 for model 2, and 3.24 for model 3. The index of normed-chi-square of model 2 was slightly smaller than 3.0 and the other two were a little bit greater than 3.0. That indicated a fit for model 2 and the latter two suggested a poor fit according to Bollen (1989). The normed-chi-square for the modified model 2 was 2.22, which was smaller than 3.0 and

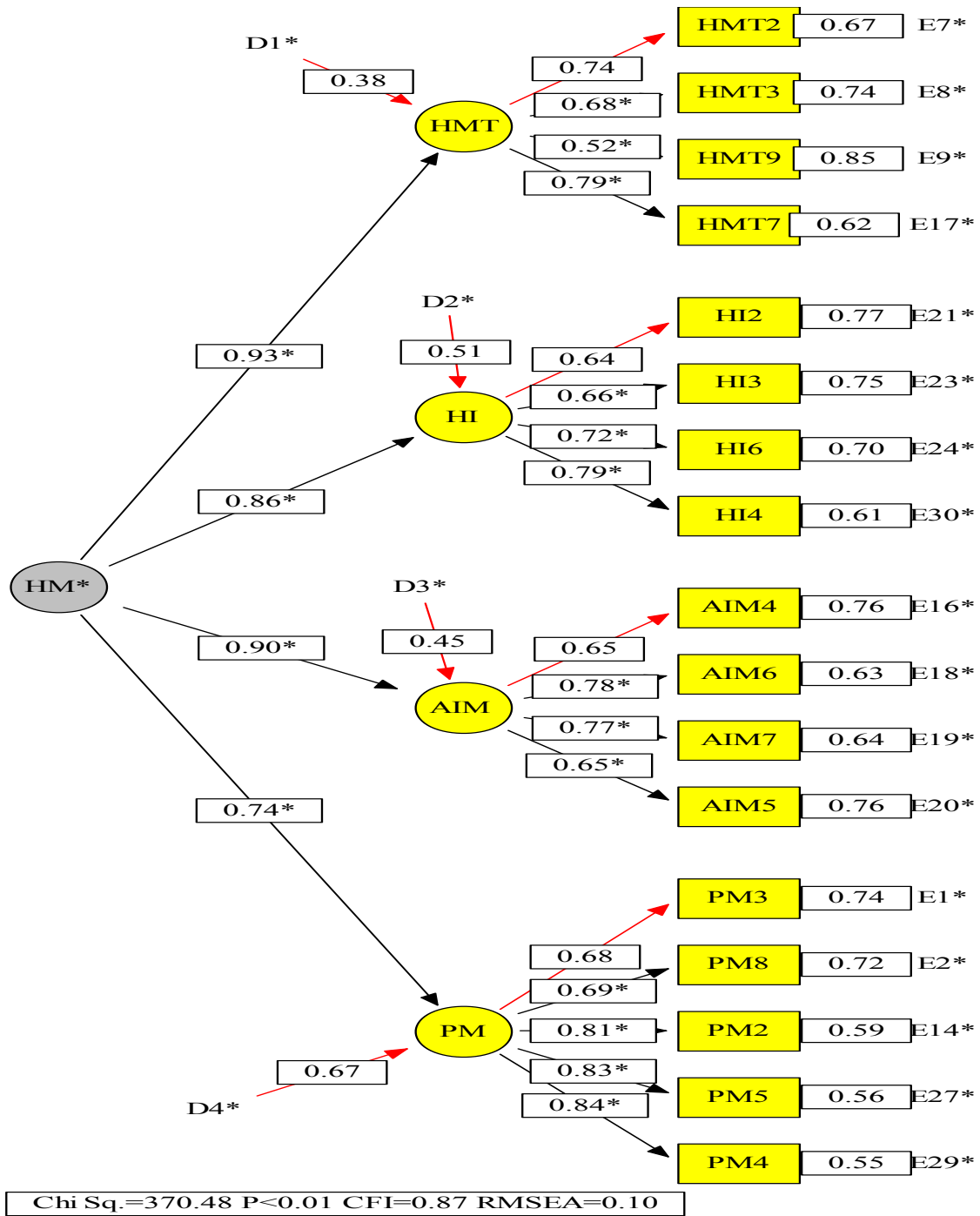

Figure 30. HMS-PA Model 3 2<sup>nd</sup> Order CFA.

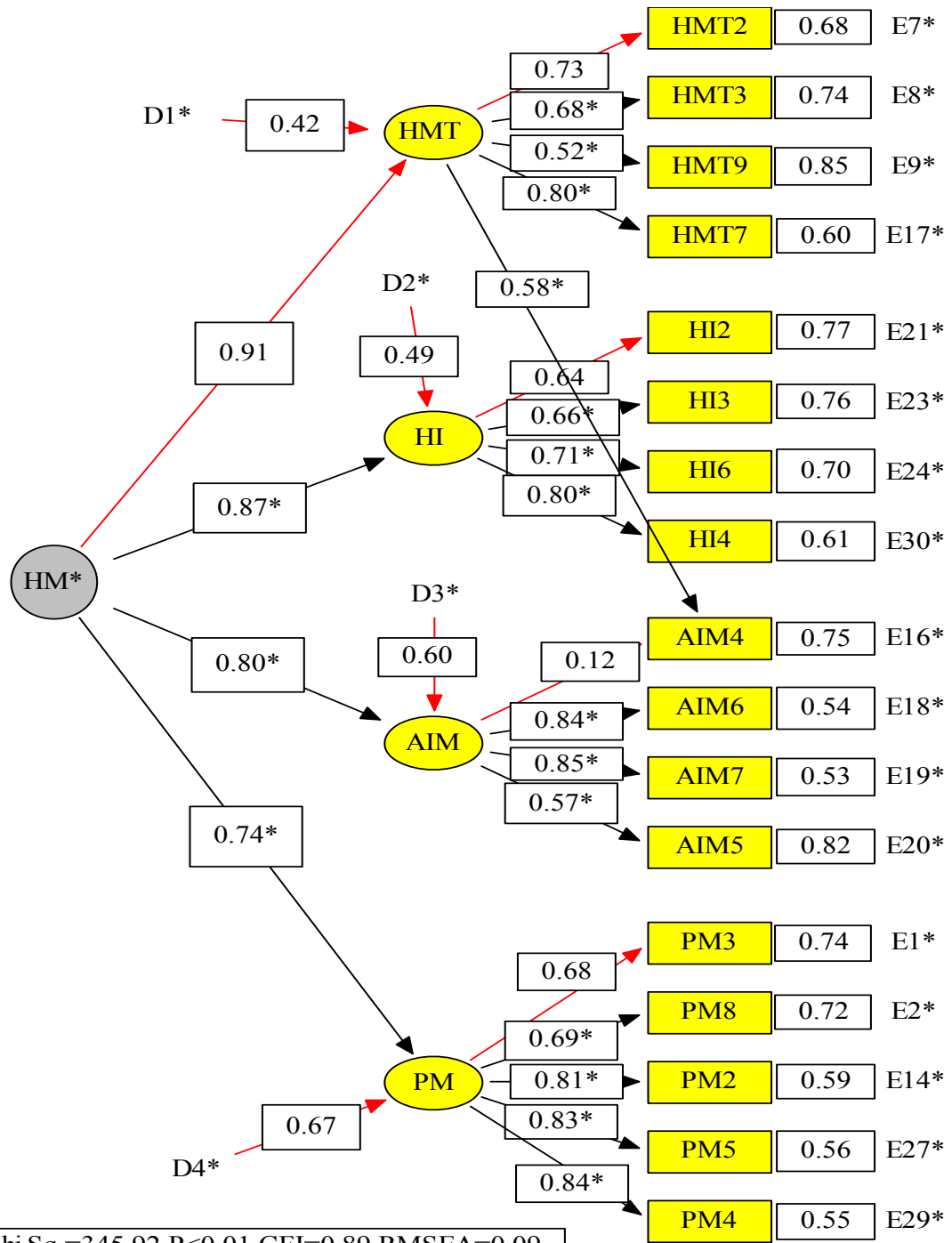

Figure 31. HMS-PA Model 3 2<sup>nd</sup> Order CFA Modified.

indicated a possible good fit too. Hu and Bentler (1999) suggested that the value of CFI greater than roughly .90 indicated a possible good fit of the model. The CFI was .793 for model 1, .923 for model 2, .873 for model 3, and .886 for modified model 3. Among these models, only model 2 which indicated a possible good fit. The GFI for model 1 was .684, .889 for model 2, and .838 for model 3, with all of them smaller than .90. The NFIs were smaller than .90 for three models, with .726 for model 1, .888 for model 2 and .829 for model 3. The NNFI was .775 for model 1, .901 for model 2, and .849 for model 3. Kline (2005) suggested that the favorable value of the Standard RMR is less than .10. The Standard RMRs of the HMS-PA model 1, model 2, and model 3 were .073, .058, and .063 respectively, indicating that the model possibly fit the data. According to Browne and Cudeck (1993), if a RMSEA is not greater than .05, then it indicates a good fit; if a RMSEA is between .05 and .08, then it suggests reasonable error of approximation; if a RMSEA is not smaller than .10, then it suggests poor fit. The RMSEA for model 1 was .098, with 90% confidence interval of (.092, .104). The RMSEA for model 2 was .090, with 90% confidence interval of (.075, .106). The RMSEA for model 3 was .098, with 90% confidence interval of (.087, .109). This indicated a fair amount of sampling error in the scores. The loadings and R-squared were reasonably high. According to these indices, in general, the second-order model of HMS-PA Model 2 fit the data, although couples of indices were not favorable. Also, HMS-PA Model 2 fit the data better than the other two models. For all the one-factor models, they poorly fit the data.

## *Confirmatory Factor Analysis for the HMS-HE*

### *Confirmatory Factor Analysis for the HMS-HE Model 1*

*First-order factor model.* This first-order model specified four factors (health motivation tendencies, health intention, action initiation, and persistency motivation), with 6-8 indicators for each factor. Each indicator was constrained to load just on the factor it was designated to measure. All the factor covariances were free to be estimated. Error terms which were associated with each indicator were uncorrelated. The indices were:  $\chi^2 (399, N = 236) = 1315.943, p < .001$ , CFI = .823, NFI = .765, NNFI = .807, GFI = .694, Standard RMR = .089, RMSEA = .099 (CI = .093, .105). The loadings ranged from .38 to .84 and the R-squared ranged from .14 to .70. Figure 32 presents this first-order health motivation model in the HMS-HE model 1. The estimates of factor loadings and error terms were along with the figure.

All parameters were reasonable and statistically significant indicated by the Wald test. A few factor loading parameters were suggested to be added by the LM test. However, no changes were made because of the meaningfulness of the model.

As can be seen in Table 17, factor correlations among the four first-order factors ranged from .81 to .99, which indicated that a higher order construct might exist. Also, because the correlation between health motivation tendency and health intention and the correlation between action initiation and persistency motivation were too high, health motivation tendency and health intention may measure the same thing, and action initiation and persistency motivation may measure the same thing too.



Table 17

*Correlations between the First-order Factors in the HMS-HE Model 1*

	Health Motivation Tendency	Health Intention	Action Initiation	Persistency Motivation
Health Motivation Tendency	1.00			
Health Intention	.99	1.00		
Action Initiation	.87	.83	1.00	
Persistency Motivation	.87	.82	.99	1.00

*Second-order factor model.* The second-order factor model included only one factor, health motivation, in place of first-order factor covariances. The indices were,  $\chi^2$  (401,  $N = 236$ ) = 1372.394,  $p < .001$ , CFI = .812, NFI = .755, NNFI = .796, GFI = .682, Standard RMR = .073, RMSEA = .102 (CI = .095, .107). The loadings ranged from .39 to .990 and the  $R$ -squared ranged from .15 to .99. Figure 33 presents this second-order health motivation model in the HMS-HE model 1. The estimates of factor loadings and disturbance terms were along with the figure. All parameters were reasonable and statistically significant indicated by the Wald test. The LM test indicated to add the similar parameters as that of in the first-order examination.

*Confirmatory factor analysis for the HMS-HE Model 1\*.* This model specified one factor, with 30 indicators in total. Error terms which were associated with each indicator were uncorrelated. The indices were:  $\chi^2$  (405,  $N = 238$ ) = 1524.671,  $p < .001$ , CFI = .783,

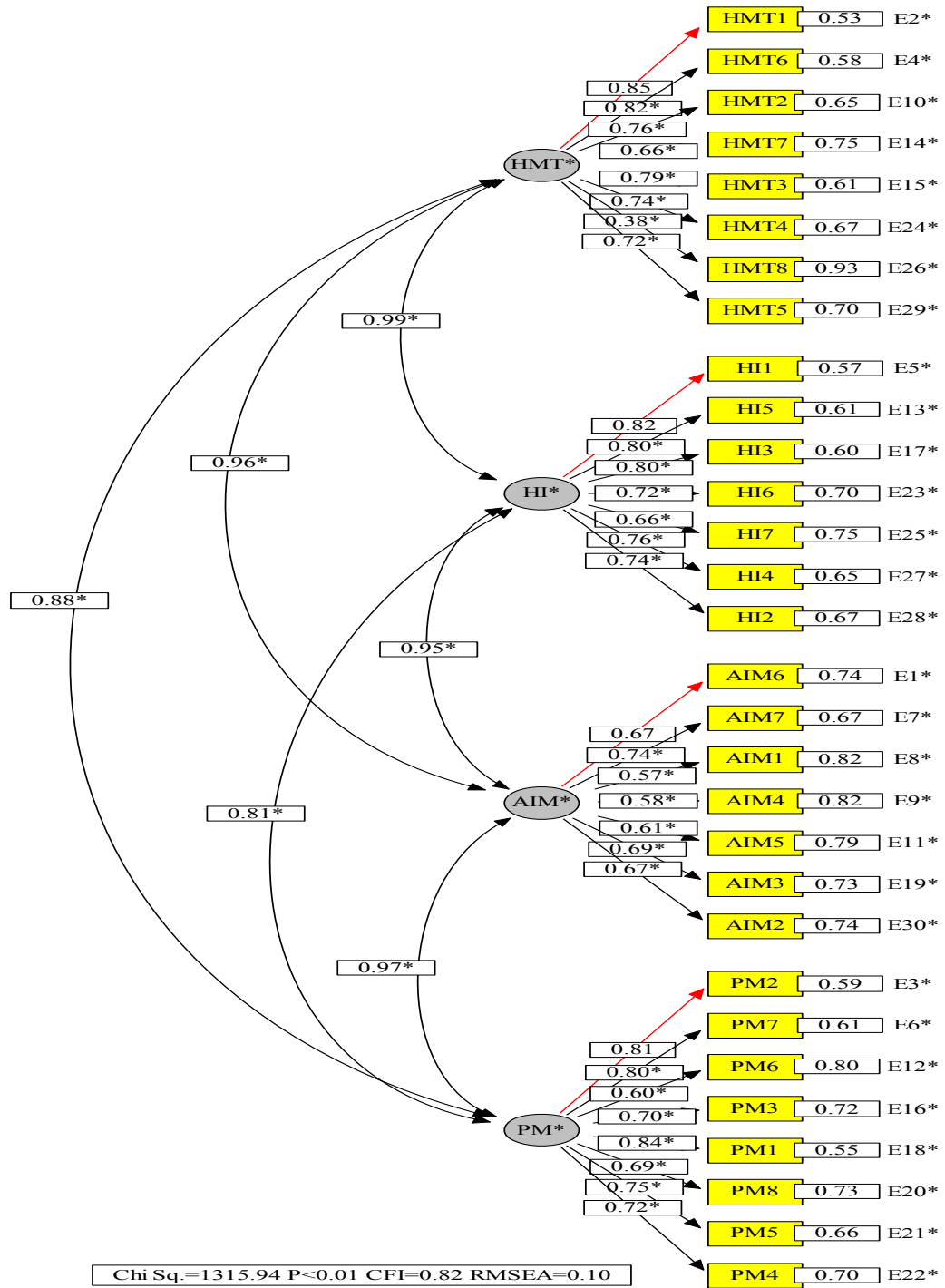

Figure 32. HMS-HE Model 1 1<sup>st</sup> Order CFA.

NFI = .728, NNFI = .767, GFI = .626, Standard RMR = .097, RMSEA = .108 (CI = .102, .114). The loadings ranged from .40 to .83 and the *R*-squared ranged from .16 to .69.

All parameters were reasonable and statistically significant indicated by the Wald test. No parameters were suggested to be added by LM test.

*Confirmatory Factor Analysis for the HMS-HE Model 2*

*First-order factor model.* The first-order model specified three factors (health motivation tendencies and health intention, action initiation motivation, and persistency motivation), with 2-5 indicators for each factor. Each indicator was constrained to load just on the factor it was designated to measure. All the factor covariances were free to be estimated. Error terms which were associated with each indicator were uncorrelated. The indices were:  $\chi^2 (51, N = 238) = 176.920, p < .001$ , CFI = .915, NFI = .886, NNFI = .891, GFI = .873, Standard RMR = .053, RMSEA = .102 (CI = .086, .118). The loadings ranged from .66 to .85 and the *R*-squared ranged from .44 to .73. Figure 34 presents this first-order health motivation model in the HMS-HE model 2. The estimates of factor loadings and error terms were along with the figure.

All parameters were reasonable and statistically significant indicated by the Wald test. Three factor loading parameters were suggested to be added by the LM test, which were HMT6 and action initiation motivation, PM5 and healthy motivation tendency and health intention, and HI2 and action initiation motivation. However, no parameters were added because the meaningfulness of the model.

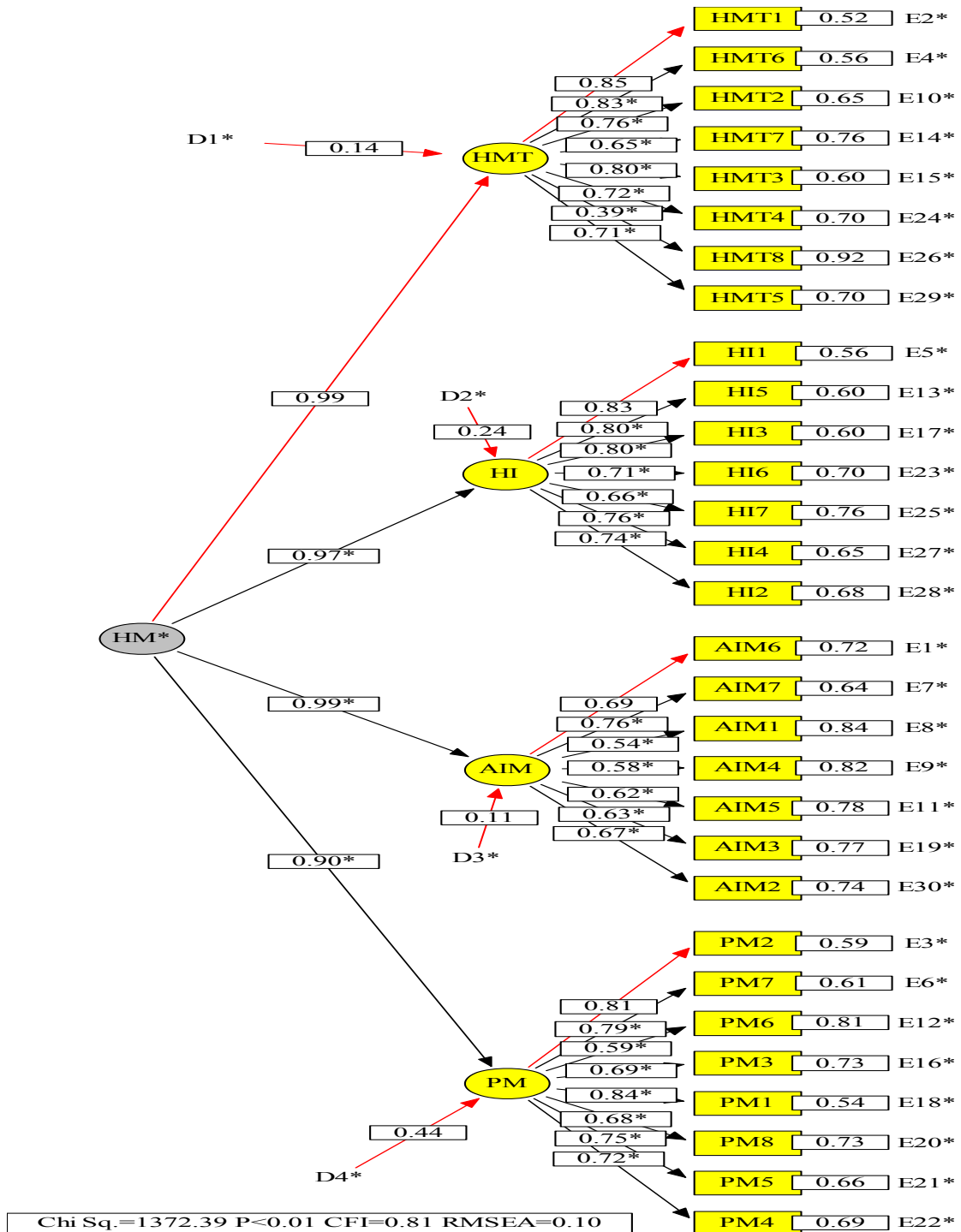

Figure 33. HMS-HE Model 1 2<sup>nd</sup> Order CFA.

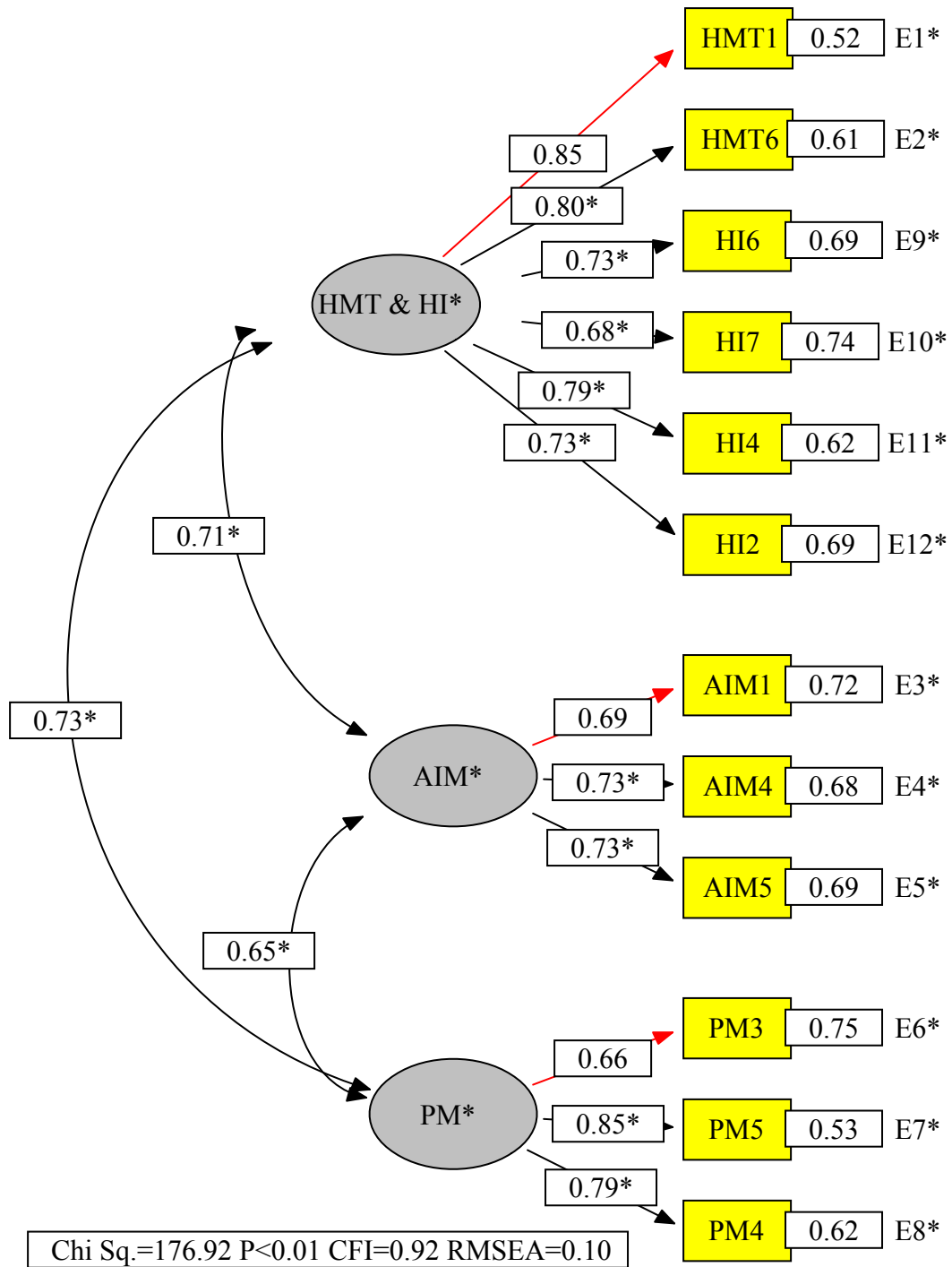

Figure 34. HMS-HE Model 2 1<sup>st</sup> Order.

As can be seen in Table 18, factor correlations among the four factors ranged from .65 to .73, which indicating that a higher order construct existed and explained the strong relationships among these four factors.

Table 18

*Correlations between the First-order Factors in the HMS-HE Model 2*

	Health Motivation Tendency and Health Intention	Action Initiation	Persistency Motivation
Health Motivation Tendency and Health Intention	1.00		
Action Initiation	.71	1.00	
Persistency Motivation	.73	.65	1.00

*Second-order factor model.* The second-order factor model included only one factor, health motivation, in place of first-order factor covariances. The indices were:  $\chi^2 (51, N = 238) = 176.916, p < .001, CFI = .915, NFI = .886, NNFI = .891, GFI = .873, Standard RMR = .053, RMSEA = .102 (CI = .086, .118)$ . The loadings ranged from .66 to .90 and the *R*-squared ranged from .44 to .80. Figure 35 presents this second-order health motivation model. The estimates of factor loadings and disturbance terms were along with the figure. The Wald test indicated that every parameter was statistically significant and no parameters dropped. The LM test suggested that a parameter between HMT6 and persistency motivation, and PM5 and healthy motivation tendency and health intention.

*Confirmatory factor analysis for the HMS-HE Model 2\**. This model specified one factor, with 12 indicators in total. Error terms which were associated with each indicator were uncorrelated. The indices were:  $\chi^2$  (54,  $N = 238$ ) = 336.356,  $p < .001$ , CFI = .810, NFI = .784, NNFI = .768, GFI = .785, Standard RMR = .082, RMSEA = .149 (CI = .133, .163). The loadings ranged from .52 to .84 and the  $R$ -squared ranged from .27 to .71. All parameters were reasonable and statistically significant indicated by the Wald test. No parameters were suggested to be added by the LM test.

*Confirmatory factor analysis for the HMS-HE Model 2 as a four-factor model.* Originally, the model of health motivation consists of four components. The exploratory factor analysis suggested three factors for the HMS-HE model 2. Therefore, the three-factor model was tested. To examine whether the four-factor model worked better, model 2 was tested as a four-factor model using higher order confirmatory factor analysis. For the second order, the  $\chi^2$  was 97.553 and the normed-chi-square was 1.95, with CFI = .968, NFI = .937, NNFI = .958, GFI = .933, Standard RMR = .043, and RMSEA = .063 (CI = .044, .082). The loadings ranged from .66 to .94, and the  $r$ -squared ranged from .43 to .88 (see Figure 36). These findings indicated that a four-factor model fit the data much better than the three-factor model which suggested by the exploratory factor analysis.

#### *Confirmatory Factor Analysis for the HMS-HE Model 3*

*First-order factor model.* The first-order model specified four factors (health motivation tendencies, health intention, action initiation, and persistency motivation), with 4 indicators for each factor. Each indicator was constrained to load just on the factor it was designated to measure. All the factor covariances were free to be estimated. Error

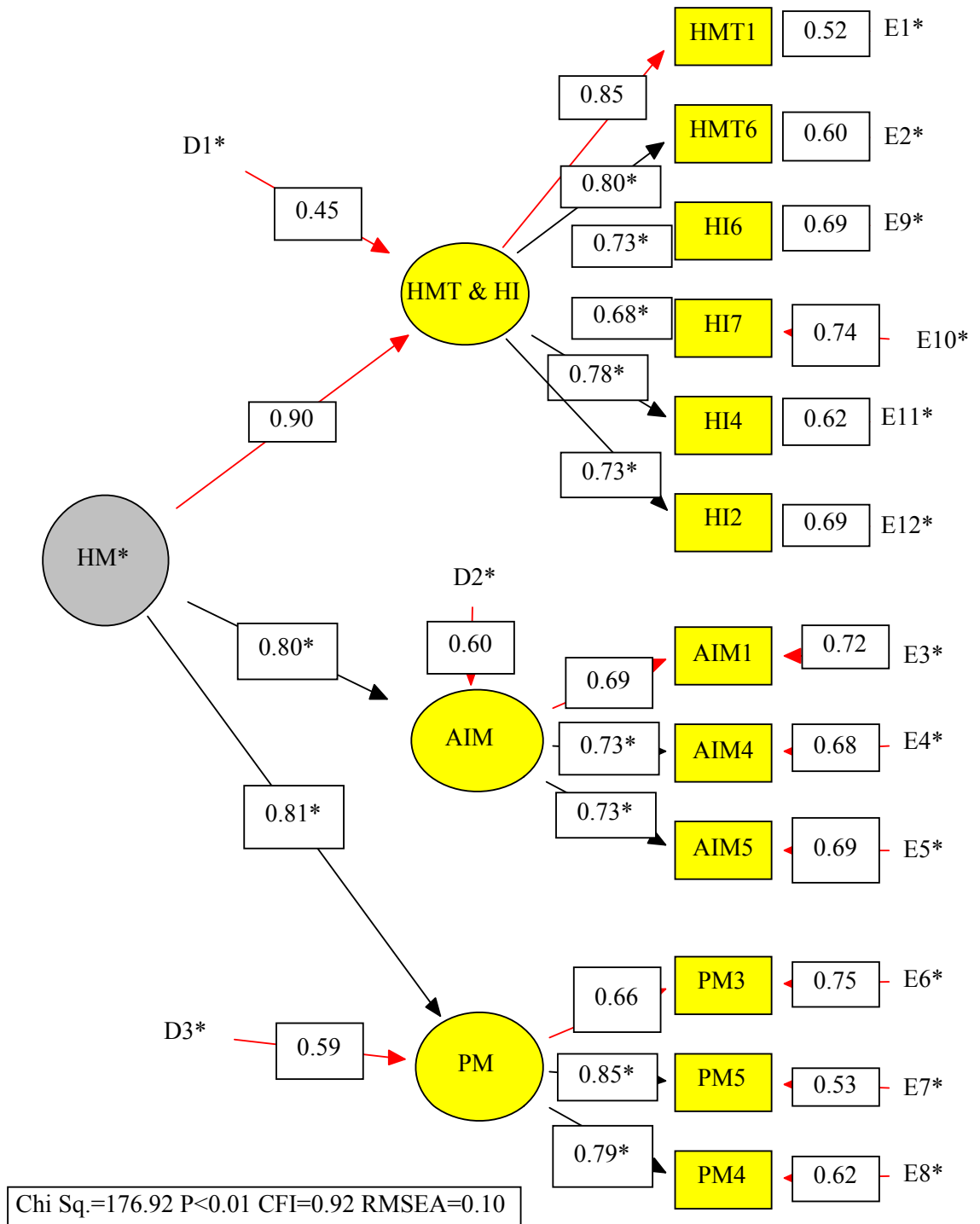

Figure 35. HMS-HE Model 2 2<sup>nd</sup> Order.



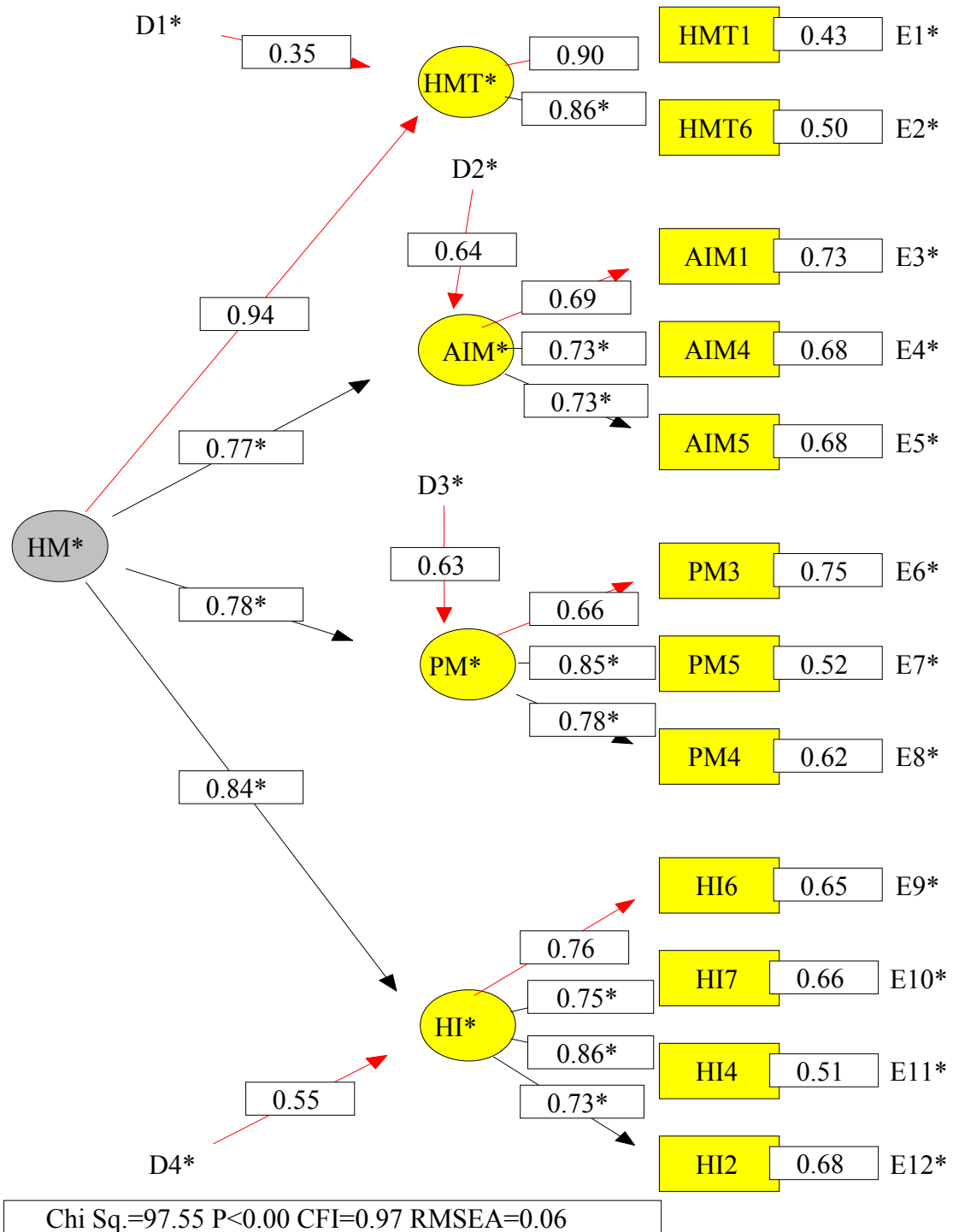

Figure 36. HMS-HE Model 2 Tested with 4 Factors 2<sup>nd</sup> Order CFA.

terms which were associated with each indicator were uncorrelated. The indices were:  $\chi^2$  (98,  $N = 238$ ) = 282.80,  $p < .001$ , CFI = .914, NFI = .875, NNFI = .894, GFI = .859, Standard RMR = .064, RMSEA = .089 (CI = .077, .101). The loadings ranged from .42 to .89 and the  $R$ -squared ranged from .17 to .78. Figure 37 presents this first-order health motivation model in the HMS-HE model 3. The estimates of factor loadings and error terms were along with the figure.

All parameters were reasonable and statistically significantly indicated by the Wald test. A few factor loading parameters were suggested to be added by the LM test. However, no changes were made because of the meaningfulness of the model.

Table 19

*Correlations between the First-order Factors in the HMS-HE Model 3*

	Health Motivation Tendency	Health Intention	Action Initiation	Persistency Motivation
Health Motivation Tendency	1.00			
Health Intention	.79	1.00		
Action Initiation	.78	.65	1.00	
Persistency Motivation	.76	.61	.81	1.00

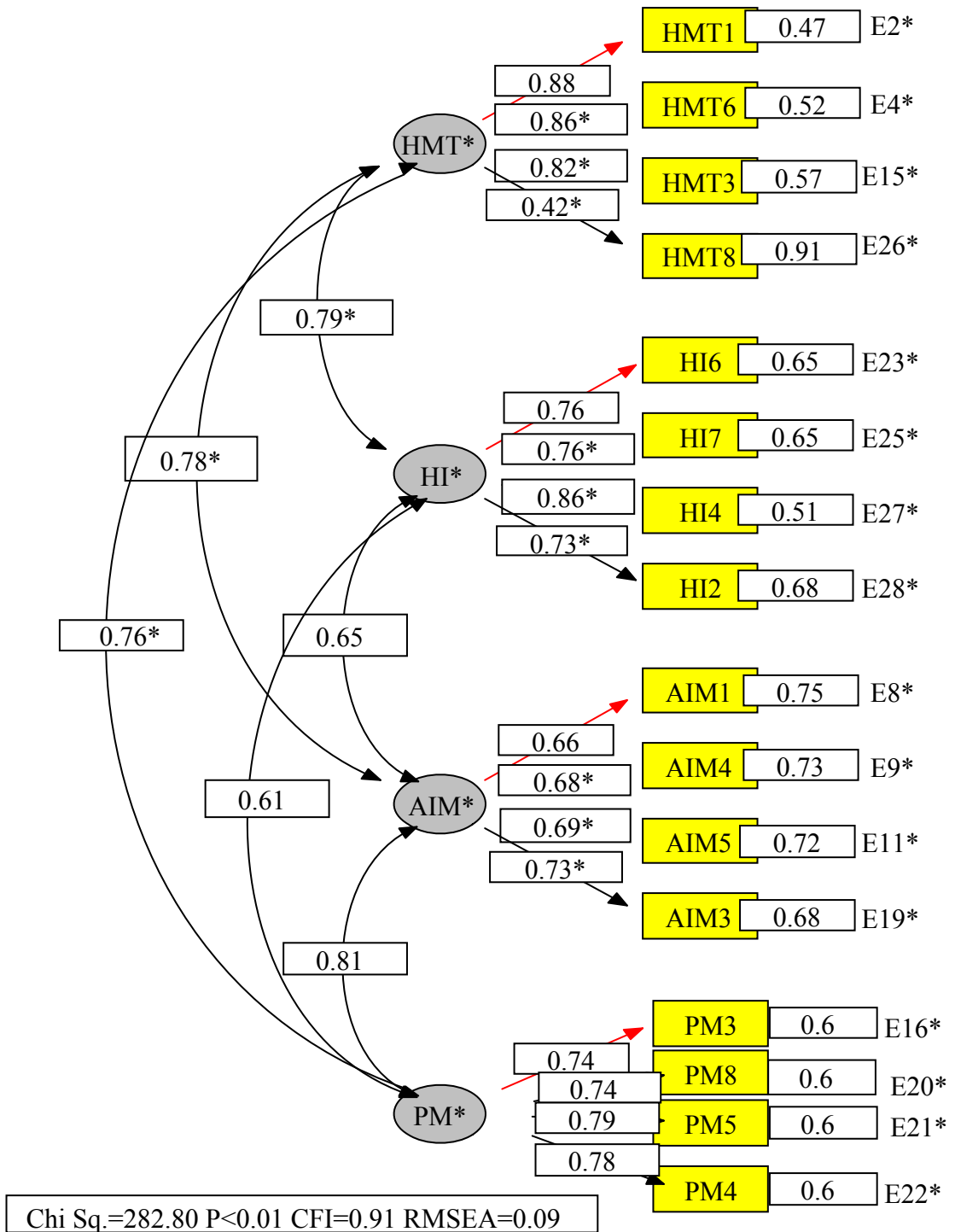

Figure 37. HMS-HE Model 3 1<sup>st</sup> Order CFA.

*Second-order factor model.* The second-order factor model included only one factor, health motivation, in place of first-order factor covariances. The indices were:  $\chi^2 (99, N = 238) = 296.153, p < .001, CFI = .908, NFI = .869, NNFI = .890, GFI = .854, Standard RMR = .068, RMSEA = .091 (CI = .079, .103)$ . The loadings ranged from .42 to .94 and the *R*-squared ranged from .17 to .88. Figure 38 presents the second-order of the HMS-HE model 3. The estimates of factor loadings and disturbance terms were along with the figure. The Wald test indicated that every parameter was statistically significant and no parameters dropped. The LM test suggested a parameter between AIM3 and PM.

*Second-order factor model modified.* Based upon the above LM test, a modified model that included the parameter between AIM3 and PM was tested. The indices were:  $\chi^2 (99, N = 238) = 247.60, p < .001, CFI = .931, NFI = .890, NNFI = .916, GFI = .876, Standard RMR = .061, RMSEA = .080 (CI = .067, .092)$ . The loadings ranged from .22 to .96 and the *R*-squared ranged from .17 to .91. Figure 39 presents this modified model. This modified model did improve the fit. The Wald test suggested no drop for any parameter. The LM test indicated adding a few parameters. However, because adding more parameters did not help the model, no more parameters were added.

*Confirmatory factor analysis for the HMS-HE Model 3\*.* This model specified one factor, with 16 indicators in total. Error terms which were associated with each indicator were uncorrelated. The indices were:  $\chi^2 (104, N = 238) = 567.599, p < .001, CFI = .783, NFI = .749, NNFI = .750, GFI = .715, Standard RMR = .086, RMSEA = .137 (CI = .126, .148)$ . The loadings ranged from .42 to .82 and the *R*-squared ranged from .18 to .67. All parameters were reasonable and statistically significantly indicated by the

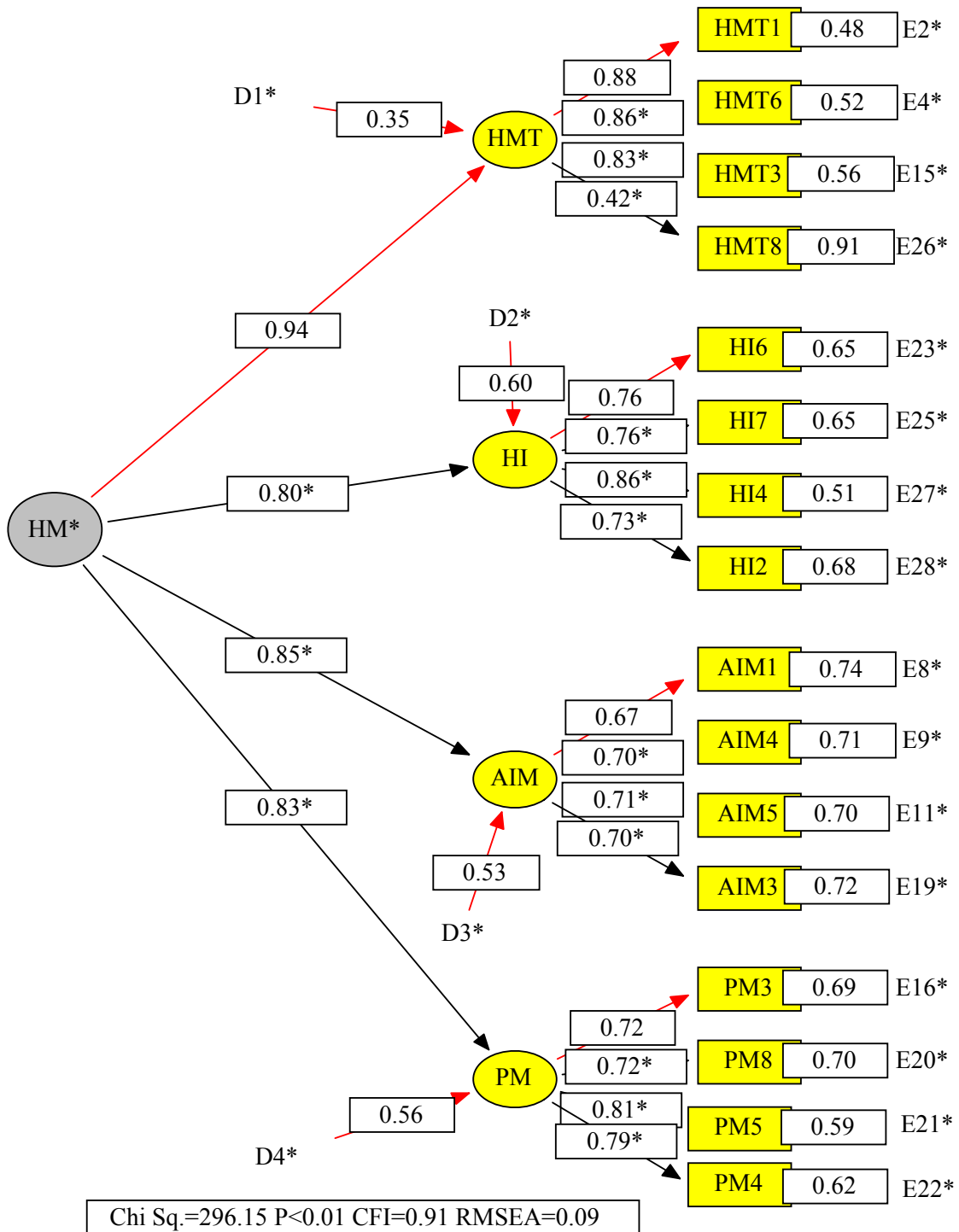

Figure 38. HMS-HE Model 3 2<sup>nd</sup> Order.

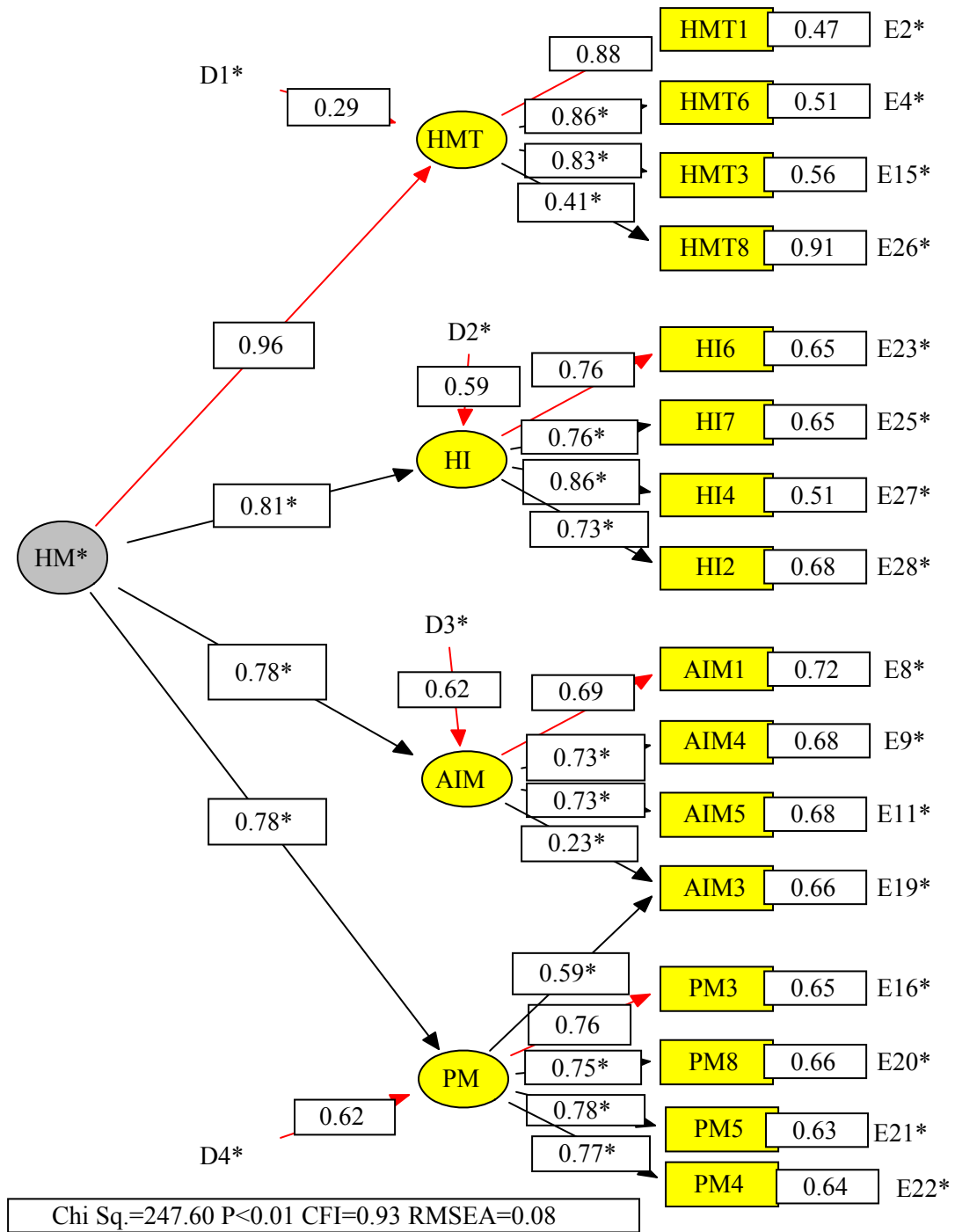

Figure 39. HMS-HE Model 3 2<sup>nd</sup> Order CFA Modified.

to .67. All parameters were reasonable and statistically significantly indicated by the Wald test. No parameters were suggested to be added by the LM test.

The  $\chi^2$ s of the second-order factor models of the three models of HMS-HE were statistically significant. But the normed-chi-squares ( $\chi^2/df$ ) were 3.42 for model 1, 3.47 for model 2, and 2.99 for model 3. Only the third one was smaller than 3, indicating a possible good fit. The CFI was .812 for model 1, .915 for model 2, and .908 for model 3. The last two were greater than .90, indicating a possible fit. The GFIs were smaller than .90 for all three models, with indices of .682, .873, and .854 respectively, indicating a possible poor fit. The NFIs were .755, .886, and .869 for model 1, 2, and 3 respectively, also suggesting a possible poor fit. The indices of NNFI for the three models were .796, .891, and .890 respectively, which indicated a possible poor fit too. The Standard RMR for model 1 was .073, .053 for model 2, and .068 for model 3, indicating that the model possibly fit the data. The RMSEA was .102 for model 1, with a 90% confidence interval of (.095, .107), was .102 for model 2, with a 90% confidence interval of (.086, .118), and was .091, with 90% confidence interval of (.079, .103). This indicated a fair amount of sampling error in the scores for the three models. The loadings and R-squared were reasonably high. According to these indices, in general, HMS-HE Model 3 marginally fit the data marginally well. When being compared the fit indices of the model 3 to its modified model, the modified model did improve the fit. This indicated that item AIM3 may need to be reworded or deleted in future studies. The original model 3 was retained in the present study for further analysis according to the parsimonious rule. That is, the simpler model is preferred. All the one-factor models poorly fit the data.

## *Predictive Validity*

### *The Health Motivation Scale in Physical Activities*

#### *The HMS-PA Model 1 Included*

*All participants included.* To investigate how well health motivation predicts physical activities, the predictive power of health value, health self-efficacy, health motivation in physical activities, and BMI was examined using regression analysis in SPSS 15.0. By examining the correlations between these predictor variables among  $N = 246$  participants, the correlations ranged from  $-.14$  to  $.56$ , indicating that there were no extremely high multicollinearity.

For the overall indices of multiple regression to predict physical activities from BMI, health value, health self-efficacy, and health motivation,  $R = .36$  and  $R^2 = .13$ . That is, when all the four variables were used as predictors, about 13% of the variances in physical activities could be predicted. The adjusted  $R^2$  was  $.12$ . The overall regression was statistically significant,  $F(4, 241) = 9.07, p < .001$ . Complete results for this regression analysis are shown in Table 20. Only health motivation in physical activities statistically significantly predicted physical activities. The predictive equation was as follows:

Physical Activities =  $160.10 + 7.10 * \text{BMI} + 18.33 * \text{Health value} + 151.67 * \text{self-efficacy} + 67.21 * \text{Health motivation}$ .

*Only for males.* Because when females and males were compared in terms of their physical activities, males statistically significantly performed more physical activities than females. Thus, gender may mediate the effects of the variables investigated above on



physical activities. Therefore, the same regression analysis was conducted among male group and female group respectively.

When males were examined, the overall indices of multiple regression to predict physical activities from BMI, health value, health self-efficacy, and health motivation,  $R = .48$  and  $R^2 = .19$ . That is, when all the four variables were used as predictors, about 19% of the variances in physical activities could be predicted. The adjusted  $R^2$  was .20. The overall regression was statistically significant,  $F(4, 91) = 6.91, p < .001$ . Complete results for this regression analysis are shown in Table 21. The correlations between predictors of health motivation, health self-efficacy, and health value were correlated for attenuation with the formula  $r^2_{xy} = r_{xy} / \text{square root of } r_x \text{ and } r_y$ . The  $r_x$  and  $r_y$  are the reliability of the scale involved. The same correction was also applied to the following related correlations. Health self-efficacy in exercise statistically significantly predicted physical activities, but not health motivation. The predictive equation was as follows: Physical Activities = (-5730.87) + 8.32 \* BMI + 144.45 \* Health value + 379.96 \* self-efficacy + 55.57 \* Health motivation.

*Only for females.* When females were examined, the overall indices of multiple regression to predict physical activities from BMI, health value, health self-efficacy, and health motivation,  $R = .29$  and  $R^2 = .09$ . That is, when all the four variables were used as predictors, about 9% of the variances in physical activities could be predicted. The adjusted  $R^2$  was .06. The overall regression was statistically significant,  $F(4, 142) = 3.34, p = .012$ . Complete results for this regression analysis are shown in Table 22. Only health motivation statistically significantly predicted physical activities. The predictive equation

Table 20

*Multiple Regression when the HMS-PA Model 1 Included*

Variables	Physical Activities	BMI	Health Value	Self- efficacy	Health motivation	<i>b</i>	$\beta$	$sr^2_{\text{unique}}$
BMI	-.02					7.10	.01	.00
Health value	.09	-.01				18.33	.02	.00
Self- efficacy	.28*** <sup>a</sup>	-.14	.14			151.67	.13	.01
Health motivation	.35***	-.01	.21***	.56***		67.21**	.27	.05
Intercept = 160.10								
Means	5760.50	23.34	17.03	21.30	28.16			
SD	5465.94	4.48	4.90	4.73	21.77			
$R^2 = .13$ $R^2_{\text{adj}} = .12$ $R = .36$								
$F(4, 241) = 9.07, p < .001$								

*Note.* <sup>a</sup> Bonferroni procedure was conducted to test the significance of each correlation; when  $p < .005$ , the correlation is significant, with the denotation of \*\*\*. This procedure was applied to the rest of correlation significance test.

\*\*  $p < .01$ , \*  $p < .05$ .

equation was as follows:

$$\text{Physical Activities} = 4141.87 + (-37.90) * \text{BMI} + (-56.66) * \text{Health value} + 50.13 * \text{self-}$$

efficacy + 64.40 \* Health motivation.

*Comparisons between males and females.* To compare the male group and the female group, the two *R*s were first transformed to Fisher *Z'*, with .52 and .30 respectively. Then the formula:

$z = (Z_1 - Z_2) / \text{square root of } (1/(N_1-3) + 1/(N_2-3))$  was applied to test the differences between these two *R*s. Because the *z* was 1.63, these two *R*s were not statistically significantly different at the level of  $\alpha = .05$ .

Table 21

*Multiple Regression when the HMS-PA Model 1 Included among Males*

Variables	Physical Activities	BMI	Health Value	Self-efficacy	Health motivation	<i>b</i>	$\beta$	$sr^2_{\text{unique}}$
BMI	.01					8.32	.01	.00
Health value	.21	.04				144.45	.12	.01
Self-efficacy	.42***	-.07	.11			379.96*	.28	.05
Health motivation	.41***	.06	.24	.58***		55.57	.17	.03
Intercept = -5730.87								
Means	6738.10	23.99	16.94	21.56	29.33			
SD	5936.27	4.31	5.08	4.39	23.31			
$R^2 = .23$ $R^2_{\text{adj}} = .20$ $R = .48$								
$F(4, 91) = 6.91, p < .001$								

\*\*\*  $p < .005$ ; \*\*  $p < .01$ ; \*  $p < .05$ .

Table 22

*Multiple Regression when the HMS-PA Model 1 Included among Females*

Variables	Physical Activities	BMI	Health Value	Self- efficacy	Health motivation	<i>b</i>	$\beta$	$sr^2_{\text{unique}}$
BMI	-.06					-37.90	-.03	.00
Health value	-.00	-.02				-56.66	-.05	.00
Self- efficacy	.19	-.18	.15			50.13	.05	.00
Health motivation	.28***	-.06	.17	.56***		64.40**	.26	.05
Intercept = 4141.87								
Means	5137.04	22.87	17.12	21.12	27.53			
SD	5098.88	4.56	4.81	4.96	20.84			
$R^2 = .09$ $R^2_{\text{adj}} = .06$ $R = .29$								
$F(4, 142) = 3.34, p = .012$								

\*\*\*  $p < .005$ ; \*\*  $p < .01$ ; \*  $p < .05$ .

*The HMS-PA Model 2 Included*

*All participants included.* Among  $N = 251$  participants, the correlations between the predictors ranged from  $-.02$  to  $.54$ , indicating that there were no extremely high

multicollinearity. For the overall indices of multiple regression to predict physical activities from BMI, health value, health self-efficacy, and health motivation,  $R = .36$  and  $R^2 = .13$ . That is, when all the four variables were used as predictors, about 13% of the variances in physical activities could be predicted. The adjusted  $R^2$  was .12. The overall regression was statistically significant,  $F(4, 246) = 9.37, p < .001$ . Complete results for this regression analysis are shown in Table 23. Health self-efficacy in exercise ( $p = .044$ ) and health motivation in physical activities ( $p < .001$ ) were significant predictors of physical activities. The predictive equation was as follows:

$$\text{Physical Activities} = -144.08 + 8.11 * \text{BMI} + 22.40 * \text{Health value} + 167.26 * \text{self-efficacy} + 149.04 * \text{Health motivation}.$$

Table 23

*Multiple Regression when the HMS-PA Model 2 Included*

Variables	Physical Activities	BMI	Health Value	Self-efficacy	Health motivation	$b$	$\beta$	$sr^2_{\text{unique}}$
BMI	-.02					8.11	.01	.00
Health value	.09	-.02				22.40	.02	.00
Self-efficacy	.29***	-.14	.14			167.26*	.15	.01
Health motivation	.34***	-.00	.20***	.54***		149.04**	.26	.05
			Intercept = -144.08					
Means	5735.87	23.42	16.96	21.27	11.75			
SD	5437.82	4.52	4.88	4.71	9.51			
			$R^2 = .13$ $R^2_{\text{adj}} = .12$ $R = .36$					
			$F(4, 246) = 9.37, p < .001$					

\*\*\*  $p < .005$ ; \*\*  $p < .01$ ; \*  $p < .05$ .

Table 24

*Multiple Regression when the HMS-PA Model 2 Included among Males*

Variables	Physical Activities	BMI	Health Value	Self-efficacy	Health motivation	<i>b</i>	$\beta$	$sr^2_{\text{unique}}$
BMI	.02					25.79	.02	.00
Health value	.20	.02				134.74	.12	.01
Self-efficacy	.42***	-.06	.10			391.38*	.29	.06
Health motivation	.41***	.05	.23	.54***		128.21	.22	.03
Intercept = -6120.59								
Means	6783.04	24.08	16.84	21.57	12.24			
SD	5883.24	4.37	5.07	4.34	10.22			
$R^2 = .24$ $R^2_{\text{adj}} = .20$ $R = .49$								
$F(4, 93) = 7.14, p < .001$								

\*\*\*  $p < .005$ ; \*\*  $p < .01$ ; \*  $p < .05$ .

*Only for males.* When males were examined, the overall indices of multiple regression to predict physical activities from the same four predictors,  $R = .49$  and  $R^2 = .24$ . That is, when all the four variables were predictors, about 24% of the variances in physical activities could be predicted. The adjusted  $R^2$  was .20. The overall regression was statistically significant,  $F(4, 93) = 7.14, p < .001$ . Complete results are shown in Table 24. Health self-efficacy statistically ( $p = .009$ ) and health motivation ( $p = .047$ ) significantly predicted healthy eating behaviors. The predictive equation was as follows: Physical Activities = (-6120.59) + 25.79 \* BMI + 134.74 \* Health value + 391.38 \* self-efficacy + 128.21 \* Health motivation.

*Only for females.* When females were examined, the overall indices of multiple regression to predict physical activities from BMI, health value, health self-efficacy, and health motivation,  $R = .29$  and  $R^2 = .09$ . That is, when all the four variables were used as predictors, about 9% of the variances in physical activities could be predicted. The adjusted  $R^2$  was .06. The overall regression was statistically significant,  $F(4, 144) = 3.36$ ,  $p = .012$ . Complete results for this regression analysis are shown in Table 25. Only health motivation ( $p = .007$ ) statistically significantly predicted physical activities. The predictive equation was as follows:

$$\text{Physical Activities} = 3841.61 + (-43.18) * \text{BMI} + (-46.50) * \text{Health value} + 66.23 * \text{self-efficacy} + 103.06 * \text{Health motivation}.$$

Table 25

*Multiple Regression when the HMS-PA Model 2 Included among Females*

Variables	Physical Activities	BMI	Health Value	Self-efficacy	Health motivation	$b$	$\beta$	$sr^2_{\text{unique}}$
BMI	-.06					-45.74	-.04	.00
Health value	.00	-.02				-44.47	-.04	.00
Self-efficacy	.19	-.17	.14			54.73	.05	.00
Health motivation	.28***	-.03	.14	.53***		144.59*	.26	.05
Intercept = 4074.17								
Means	5089.03	22.87	17.08	21.11	11.52			
SD	5081.14	4.53	4.79	4.94	9.08			
$R^2 = .09$ $R^2_{\text{adj}} = .06$ $R = .29$								
$F(4, 144) = 3.36, p = .012$								

\*\*\*  $p < .005$ ; \*\*  $p < .01$ ; \*  $p < .05$ .

Table 26

*Multiple Regression when the HMS-PA Model 3 Included*

Variables	Physical Activities	BMI	Health Value	Self- efficacy	Health motivation	<i>b</i>	$\beta$	$sr^2_{\text{unique}}$
BMI	-.02					10.20	.01	.00
Health value	.09	-.03				22.49	.02	.00
Self- efficacy	.29***	-.14	.14			180.35*	.16	.02
Health motivation	.32***	.00	.20***	.55***		106.02**	.23	.04
Intercept = -426.89								
Means	5735.87	23.42	16.96	21.27	16.09			
SD	5437.82	4.53	4.88	4.71	12.00			
$R^2 = .12$ $R^2_{\text{adj}} = .11$ $R = .35$								
$F(4, 246) = 8.56, p < .001$								

\*\*\*  $p < .005$ ; \*\*  $p < .01$ ; \*  $p < .05$ .

*Comparisons between males and females.* To compare the male group and the female group, the two  $R$ s were first transformed to Fisher  $Z'$ , with .53 and .30 respectively. Then the formula:  $z = (Z_1 - Z_2)/\text{square root of } (1/(N_1-3)+1/(N_2-3))$  was applied to test the differences between these two  $R$ s. Because the  $z$  was 1.70, these two  $R$ s were not statistically significantly different at the level of  $\alpha = .05$ .



*The HMS-PA Model 3 Included*

*All participants included.* Among  $N = 251$  participants, the correlations between the predictors ranged from  $-.14$  to  $.55$ , indicating that there were no extremely high multicollinearity. For the overall indices of multiple regression to predict physical activities from BMI, health value, health self-efficacy, and health motivation,  $R = .35$  and  $R^2 = .12$ . That is, when all the four variables were used as predictors, about 12% of the variances in physical activities could be predicted. The adjusted  $R^2$  was  $.11$ . The overall regression was statistically significant,  $F(4, 246) = 8.56, p < .001$ . Complete results for this regression analysis are shown in Table 26. Health self-efficacy in exercise and health motivation in physical activities were significant predictors of physical activities. The predictive equation was as follows:

Physical Activities =  $(-426.89) + 10.20 * \text{BMI} + 22.49 * \text{Health value} + 180.35 * \text{self-efficacy} + 106.02 * \text{Health motivation}$ .

*Only for males.* When males were examined, the overall indices of multiple regression to predict physical activities from BMI, health value, health self-efficacy, and health motivation,  $R = .47$  and  $R^2 = .23$ . That is, when all the four variables were used as predictors, about 23% of the variances in physical activities could be predicted. The adjusted  $R^2$  was  $.19$ . The overall regression was statistically significant,  $F(4, 93) = 6.76, p < .001$ . Complete results for this regression analysis are shown in Table 27. Health self-efficacy in exercise statistically significantly predicted healthy eating behaviors, but not health motivation. The predictive equation was as follows:

Physical Activities =  $(-6526.54) + 27.44 * \text{BMI} + 138.85 * \text{Health value} + 410.65 * \text{self-}$

efficacy + 87.08 \* Health motivation.

*Only for females.* When females were examined, the overall indices,  $R = .28$  and  $R^2 = .08$ . That is, when all the four variables were used as predictors, about 8% of the variances in physical activities could be predicted. The adjusted  $R^2$  was .06. The overall regression was statistically significant,  $F(4, 144) = 2.96, p = .022$ . Complete results for this regression analysis are shown in Table 28. Only health motivation statistically significantly predicted physical activities. The predictive equation was as follows:  
Physical Activities = 3841.61 + (-43.18) \* BMI + (-46.50) \* Health value + 66.23 \* self-efficacy + 103.06 \* Health motivation.

*Comparisons between males and females.* To compare the male group and the female group, their  $R$ s were transformed to Fisher  $Z'$ , with .51 and .29 respectively. Then the formula:  $z = (Z_1 - Z_2) / \text{square root of } (1/(N_1-3) + 1/(N_2-3))$  was applied to test the differences between these two  $R$ s. Because the  $z$  was 1.63, these two  $R$ s were not statistically significantly different at the level of  $\alpha = .05$ .

### *The Health Motivation Scale in Healthy Eating*

#### *The HMS-HE Model 1 Included*

*All participants included.* Among  $N = 247$  participants, the correlations between the predictors ranged from -.11 to .48, indicating that there were no extremely high multicollinearity. The overall indices of multiple regression to predict healthy eating behaviors from BMI, health value, health self-efficacy, and health motivation,  $R = .74$  and  $R^2 = .55$ . That is, when all the four variables were used as predictors, about 55% of the variances in healthy eating behaviors could be predicted. The adjusted  $R^2$  was .54.

Table 27

*Multiple Regression when the HMS-PA Model 3 Included among Males*

Variables	Physical Activities	BMI	Health Value	Self-efficacy	Health motivation	<i>b</i>	$\beta$	$sr^2_{\text{unique}}$
BMI	.02					27.44	.02	.00
Health value	.20	-.02				138.85	.12	.01
Self-efficacy	.42***	-.06	.10			410.65*	.30	.06
Health motivation	.39***	.06	.25	.56***		87.08	.19	.02
Intercept = -6526.54								
Means	6783.04	24.08	16.84	21.57	16.66			
SD	5883.24	4.37	5.06	4.34	12.84			
$R^2 = .23$ $R^2_{\text{adj}} = .19$ $R = .47$								
$F(4, 93) = 6.76, p < .001$								

\*\*\*  $p < .005$ ; \*\*  $p < .01$ ; \*  $p < .05$ .

Table 28

*Multiple Regression when the HMS-PA Model 3 Included among Females*

Variables	Physical Activities	BMI	Health Value	Self-efficacy	Health motivation	<i>b</i>	$\beta$	$sr^2_{\text{unique}}$
BMI	-.06					-43.18	-.04	.00
Health value	.00	-.02				-41.50	-.04	.00
Self-efficacy	.19	-.17	.14			66.22	.06	.00
Health motivation	.26***	-.04	.16	.55***		103.06*	.23	.04
Intercept = 3841.61								
Means	5089.03	22.87	17.08	21.11	15.83			
SD	5081.14	4.53	4.79	4.94	11.52			
$R^2 = .08$ $R^2_{\text{adj}} = .05$ $R = .28$								
$F(4, 144) = 2.96, p = .022$								

\*\*\*  $p < .005$ ; \*\*  $p < .01$ ; \*  $p < .05$ .

The overall regression was statistically significant,  $F(4, 242) = 74.36, p < .001$ . Other indices are shown in Table 29. Health self-efficacy in nutrition and health motivation in healthy eating statistically significantly predicted food choice. The predictive equation was as follows:

$$\text{Food Habits} = 4.96 + .04 * \text{BMI} + .03 * \text{Health value} + .19 * \text{self-efficacy} + .16 * \text{Health motivation}.$$

*Only for males.* When males were examined, the overall indices,  $R = .79$  and  $R^2 = .63$ .

That is, when all the four variables were used as predictors, about 63% of the variances in healthy eating behaviors could be predicted. The adjusted  $R^2$  was .62. The overall regression was statistically significant,  $F(4, 92) = 39.28, p < .001$ . See Table 30 for other

Table 29

*Multiple Regression when the HMS-HE Model 1 Included*

Variables	Healthy eating	BMI	Health value	Self-efficacy	Health motivation	<i>b</i>	$\beta$	$sr^2_{\text{unique}}$
BMI	-.05					.04	.03	.00
Health value	.18***	-.01				.03	.02	.00
Self-efficacy	.46***	-.06	.09			.19**	.14	.02
Health motivation	.73***	-.11	.22***	.48***		.16**	.66	.32
Intercept = 4.96								
Means	12.81	23.52	16.97	16.71	22.28			
SD	5.74	4.60	4.90	4.47	24.17			
$R^2 = .55 R^2_{\text{adj}} = .54 R = .74$								
$F(4, 242) = 74.36, p < .001$								

\*\*\*  $p < .005$ ; \*\*  $p < .01$ ; \*  $p < .05$ .

indices. Health self-efficacy in nutrition and health motivation statistically significantly predicted food choice. The predictive equation was as follows:

Food Habits = 5.05 + .04 \* BMI + (-.08) \* Health value + .26 \* self-efficacy + .15 \* Health motivation.

*Only for females.* When females were examined, the overall indices of multiple regression to predict healthy eating behaviors from BMI, health value, health self-efficacy, and health motivation,  $R = .72$  and  $R^2 = .52$ . That is, when all the four variables were used as predictors, about 52% of the variances in healthy eating behaviors could be predicted. The adjusted  $R^2$  was .51. The overall regression was statistically significant,  $F(4, 140) = 38.11, p < .001$ . Complete results for this regression analysis are shown in Table 31. Only health motivation in healthy eating statistically significantly predicted food choice. The predictive equation was as follows:

Food Habits = 4.82 + .02 \* BMI + .12 \* Health value + .12 \* self-efficacy + .17 \* Health motivation.

*Comparisons between males and females.* To compare the male group and the female group, the two  $R$ s were first transformed to Fisher  $Z'$ , with 1.07 and .91 respectively.

Then the formula:

$z = (Z_1 - Z_2) / \text{square root of } (1/(N_1-3) + 1/(N_2-3))$  was applied to test the differences between these two  $R$ s. Because the  $z$  was 1.19, these two  $R$ s were not statistically significantly different at the level of  $\alpha = .05$ .

#### *The HMS-HE Model 2 Included*

*All participants included.* Among  $N = 249$  participants, the correlations between the

Table 30

*Multiple Regression when the HMS-HE Model 1 Included among Males*

Variables	Healthy eating	BMI	Health value	Self-efficacy	Health motivation	<i>b</i>	$\beta$	$sr^2_{\text{unique}}$
BMI	.03					.04	.03	.00
Health value	.10	.01				-.08	.07	.00
Self-efficacy	.53***	-.06	.02			.26**	.21	.03
Health motivation	.77***	.02	.24	.47***		.15**	.69	.34
Intercept = 5.05								
Means	11.75	24.17	16.87	16.44	18.76			
SD	5.94	4.52	5.09	4.66	27.50			
$R^2 = .63$ $R^2_{\text{adj}} = .62$ $R = .79$								
$F(4, 92) = 39.28, p < .001$								

\*\*\*  $p < .005$ ; \*\*  $p < .01$ ; \*  $p < .05$ .

Table 31

*Multiple Regression when the HMS-HE Model 1 Included among Females*

Variables	Healthy eating	BMI	Health value	Self-efficacy	Health motivation	<i>b</i>	$\beta$	$sr^2_{\text{unique}}$
BMI	-.10					.02	.02	.00
Health value	.25***	-.00				.12	.11	.01
Self-efficacy	.42***	-.02	.11			.12	.09	.00
Health motivation	.71***	-.18	.20	.49***		.17**	.65	.30
Intercept = 4.82								
Means	13.94	22.98	17.10	16.97	24.69			
SD	5.51	4.59	4.82	4.32	24.66			
$R^2 = .52$ $R^2_{\text{adj}} = .51$ $R = .72$								
$F(4, 140) = 38.11, p < .001$								

\*\*\*  $p < .005$ ; \*\*  $p < .01$ ; \*  $p < .05$ .

predictors ranged from -.08 to .47, indicating that there were no extremely high multicollinearity. For the overall indices of multiple regression to predict food choice from BMI, health value, health self-efficacy, and health motivation,  $R = .74$  and  $R^2 = .54$ . That is, when all the four variables were used as predictors, about 54% of the variances in physical activities could be predicted. The adjusted  $R^2$  was .54. The overall regression was statistically significant,  $F(4, 244) = 72.41, p < .001$ . Complete results for this regression analysis are shown in Table 32. Health self-efficacy in nutrition ( $p < .001$ ) and health motivation in healthy eating ( $p < .001$ ) were significantly predictive of food choice. The predictive equation was as follows:

$$\text{Food Habits} = 4.56 + .02 * \text{BMI} + .03 * \text{Health value} + .22 * \text{self-efficacy} + .37 * \text{Health motivation}.$$

Table 32

*Multiple Regression when the HMS-HE Model 2 Included*

Variables	Healthy eating	BMI	Health value	Self-efficacy	Health motivation	$b$	$\beta$	$sr^2_{\text{unique}}$
BMI	-.05					.02	.01	.00
Health value	.17***	-.02				.03	.03	.00
Self-efficacy	.47***	-.05	.07			.22**	.18	.02
Health motivation	.72***	-.08	.20***	.47***		.37**	.63	.30
Intercept = 4.56								
Means	12.81	23.50	16.96	16.71	9.56			
SD	5.75	4.59	4.91	4.50	9.75			
$R^2 = .54$ $R^2_{\text{adj}} = .54$ $R = .74$								
$F(4, 244) = 72.41, p < .001$								

\*\*\*  $p < .005$ ; \*\*  $p < .01$ ; \*  $p < .05$ .

*Only for males.* When males were examined, the overall indices,  $R = .79$  and  $R^2 = .63$ . That is, when all the four variables were used as predictors, about 63% of the variances in healthy eating behaviors could be predicted. The adjusted  $R^2$  was .61. The overall regression was statistically significant,  $F(4, 92) = 39.07, p < .001$ . Complete results for this regression analysis are shown in Table 33. Health self-efficacy in nutrition ( $p = .002$ ) and health motivation in healthy eating ( $p < .001$ ) statistically significantly predicted food choice. The predictive equation was as follows:

$$\text{Food Habits} = 5.43 + (-.01) * \text{BMI} + (-.07) * \text{Health value} + .29 * \text{self-efficacy} + .37 * \text{Health motivation}.$$

Table 33

*Multiple Regression when the HMS-HE Model 2 Included among Males*

Variables	Healthy eating	BMI	Health value	Self-efficacy	Health motivation	<i>b</i>	$\beta$	$sr^2_{\text{unique}}$
BMI	.03					-.01	-.01	.00
Health value	.10	.01				-.07	-.06	.00
Self-efficacy	.53***	-.06	.02			.29**	.23	.04
Health motivation	.76***	.08	.22	.44***		.37**	.67	.34
						Intercept = 5.43		
Means	11.75	24.17	16.87	16.44	8.12			
SD	5.93	4.52	5.09	4.66	10.98			
								$R^2 = .63$ $R^2_{\text{adj}} = .61$ $R = .79$
								$F(4, 92) = 39.07, p < .001$

\*\*\*  $p < .005$ ; \*\*  $p < .01$ ; \*  $p < .05$ .



*Only for females.* When females were examined, the overall indices of multiple regression to predict healthy eating behaviors from BMI, health value, health self-efficacy, and health motivation,  $R = .71$  and  $R^2 = .50$ . That is, when all the four variables were used as predictors, about 50% of the variances in healthy eating behaviors could be predicted. The adjusted  $R^2$  was .51. The overall regression was statistically significant,  $F(4, 142) = 35.68, p < .001$ . Complete results for this regression analysis are shown in Table 34. Self-efficacy ( $p = .048$ ) and health motivation statistically significantly predicted food choice. The predictive equation was as follows:

Food Habits =  $3.94 + .02 * \text{BMI} + .12 * \text{Health value} + .17 * \text{self-efficacy} + .38 * \text{Health motivation}$ .

*Comparisons between males and females.* To compare the male group and the female group, the two  $R$ s were first transformed to Fisher  $Z'$ , with 1.07 and .89 respectively. Then the formula:  $z = (Z_1 - Z_2) / \text{square root of } (1/(N_1-3) + 1/(N_2-3))$  was applied to test the differences between these two  $R$ s. Because the  $z$  was 1.33, these two  $R$ s were not statistically significantly different at the level of  $\alpha = .05$ .

#### *The HMS-HE Model 3 Included*

*All participants included.* Among  $N = 249$  participants, the correlations between the predictors ranged from -.10 to .49, indicating that there were no extremely high multicollinearity. For the overall indices of multiple regression to predict food choice from BMI, health value, health self-efficacy, and health motivation,  $R = .74$  and  $R^2 = .55$ . That is, when all the four variables were used as predictors, about 55% of the variances in physical activities could be predicted. The adjusted  $R^2$  was .54. The overall regression

Table 34

*Multiple Regression when the HMS-HE Model 2 Included among Females*

Variables	Healthy eating	BMI	Health value	Self-efficacy	Health motivation	<i>b</i>	$\beta$	$sr^2_{\text{unique}}$
BMI	-.09					.02	.02	.00
Health value	.22***	-.01				.12	.11	.01
Self-efficacy	.44***	-.02	.08			.17*	.14	.01
Health motivation	.69***	-.17	.17	.48***		.38**	.61	.27
Intercept = 3.94								
Means	13.39	22.96	17.07	16.97	10.51			
SD	5.55	4.56	4.83	4.38	8.83			
$R^2 = .50$ $R^2_{\text{adj}} = .49$ $R = .71$								
$F(4, 142) = 35.68, p < .001$								

\*\*\*  $p < .005$ ; \*\*  $p < .01$ ; \*  $p < .05$ .

was statistically significant,  $F(4, 244) = 74.74, p < .001$ . Complete results for this regression analysis are shown in Table 35. Health self-efficacy in nutrition and health motivation in healthy eating were significantly predictive of food choice. The predictive equation was as follows:

$$\text{Food Habits} = 4.95 + .03 * \text{BMI} + .04 * \text{Health value} + .19 * \text{self-efficacy} + .30 * \text{Health motivation}.$$

*Only for males.* When males were examined, the overall indices of multiple regression to predict healthy eating behaviors from the same factors,  $R = .79$  and  $R^2 = .63$ . That is, when all the four variables were used as predictors, about 63% of the variances in healthy eating behaviors could be predicted. The adjusted  $R^2$  was .61. The overall

regression was statistically significant,  $F(4, 92) = 38.78, p < .001$ . Other indices are shown in Table 36. Health self-efficacy in nutrition and health motivation in healthy eating statistically significantly predicted food choice. The predictive equation was: Food Habits = 4.90 + .03 \* BMI + (-.07) \* Health value + .27 \* self-efficacy + .28 \* Health motivation.

Table 35

*Multiple Regression when the HMS-HE Model 3 Included*

Variables	Healthy eating	BMI	Health value	Self-efficacy	Health motivation	<i>b</i>	$\beta$	$sr^2_{\text{unique}}$
BMI	-.05					.03	.03	.00
Health value	.17***	-.02				.04	.03	.00
Self-efficacy	.47***	-.05	.07			.19**	.15	.02
Health motivation	.73***	-.10	.20***	.49***		.30**	.65	.31
Intercept = 4.95								
Means	12.81	23.50	16.96	16.71	11.28			
SD	5.75	4.59	4.91	4.50	12.70			
$R^2 = .55$ $R^2_{\text{adj}} = .54$ $R = .74$								
$F(4, 244) = 74.74, p < .001$								

\*\*\*  $p < .005$ ; \*\*  $p < .01$ ; \*  $p < .05$ .

*Only for females.* When females were examined, the overall indices of multiple regression to predict healthy eating behaviors from BMI, health value, health self-

efficacy, and health motivation,  $R = .72$  and  $R^2 = .52$ . That is, when all the four variables were used as predictors, about 52% of the variances in healthy eating behaviors could be predicted. The adjusted  $R^2$  was .51. The overall regression was statistically significant,  $F(4, 142) = 38.49, p < .001$ . Complete results for this regression analysis are shown in Table 37. Only health motivation in healthy eating statistically significantly predicted food choice. The predictive equation was as follows:

Food Habits =  $4.77 + .03 * \text{BMI} + .12 * \text{Health value} + .12 * \text{self-efficacy} + .31 * \text{Health motivation}$ .

*Comparisons between males and females.* To compare the male group and the female group, the two  $R$ s were first transformed to Fisher  $Z'$ , with 1.07 and .91 respectively. Then the formula:  $z = (Z_1 - Z_2) / \text{square root of } (1/(N_1-3) + 1/(N_2-3))$  was applied to test the differences between these two  $R$ s. Because the  $z$  was 1.19, these two  $R$ s were not statistically significantly different at the level of  $\alpha = .05$ .

#### *When Using Motivation Ranking Scale and the Revised Personal Striving Assessment*

##### *Predicting Physical Activities*

*Using the scores obtained by the motivation ranking scale.* When using the ranking of health motivation among 16 motives as a predictor instead of health motivation in physical activities, the overall indices of multiple regression,  $R = .28$  and  $R^2 = .08$ . That is, when all the four variables were used as predictors, about 8% of the variances in physical activities could be predicted. The adjusted  $R^2$  was .06. The overall regression was statistically significant,  $F(4, 252) = 5.29, p < .001$ . Health self-efficacy in exercise was significantly predictive of physical activities, but not the ranking of health motivation.

Table 36

*Multiple Regression when the HMS-HE Model 3 Included among Males*

Variables	Healthy eating	BMI	Health value	Self-efficacy	Health motivation	<i>b</i>	$\beta$	$sr^2_{\text{unique}}$
BMI	.03					.03	.02	.00
Health value	.10	.01				-.07	-.06	.00
Self-efficacy	.53***	-.06	.02			.27**	.22	.04
Health motivation	.77***	.03	.22	.47***		.28**	.68	.34
Intercept = 4.90								
Means	11.75	24.17	16.87	16.44	9.95			
SD	5.93	4.52	5.09	4.66	14.29			
$R^2 = .63$ $R^2_{\text{adj}} = .61$ $R = .79$								
$F(4, 92) = 38.78, p < .001$								

\*\*\*  $p < .005$ ; \*\*  $p < .01$ ; \*  $p < .05$ .

Table 37

*Multiple Regression when the HMS-HE Model 3 Included among Females*

Variables	Healthy eating	BMI	Health value	Self-efficacy	Health motivation	<i>b</i>	$\beta$	$sr^2_{\text{unique}}$
BMI	-.09					.03	.03	.00
Health value	.22***	-.01				.12	.10	.01
Self-efficacy	.44***	-.02	.08			.12**	.10	.01
Health motivation	.71***	-.18	.17	.52***		.31**	.65	.29
Intercept = 4.77								
Means	13.39	22.96	17.07	16.97	12.15			
SD	5.55	4.56	4.83	4.38	11.63			
$R^2 = .52$ $R^2_{\text{adj}} = .51$ $R = .72$								
$F(4, 142) = 38.49, p < .001$								

\*\*\*  $p < .005$ ; \*\*  $p < .01$ ; \*  $p < .05$ .

When males were examined, the overall indices of multiple regression to predict physical activities from BMI, health value, health self-efficacy, and health motivation ranking,  $R = .44$  and  $R^2 = .19$ . That is, when all the five variables were used as predictors, about 19% of the variances in physical activities could be predicted. The adjusted  $R^2$  was .16. The overall regression was statistically significant,  $F(4, 94) = 5.59, p < .001$ . Only self-efficacy in physical activities statistically significantly predicted physical activities. The predictive equation was as follows:

Physical Activities = (-9778.09) + 86.76 \* BMI + 183.91 \* Health value + 520.74 \* self-efficacy + 29.96 \* Health motivation.

When females were examined, the overall indices of multiple regression to predict physical activities from BMI, health value, health self-efficacy, and health motivation ranking,  $R = .23$  and  $R^2 = .05$ . That is, when all the five variables were used as predictors, about 5% of the variances in physical activities could be predicted. The adjusted  $R^2$  was .03. The overall regression was not statistically significant,  $F(4, 148) = 2.03, p = .09$ . No single predictor that statistically predicted physical activities was found either.

*Using the scores of the health motivation measured by the revised personal striving assessment.* When using the health motivation measured by personal strivings as a predictor in place of health motivation in physical activities, the overall indices of multiple regression,  $R = .30$  and  $R^2 = .09$ . The adjusted  $R^2$  was .08. The overall regression was statistically significant,  $F(4, 253) = 6.41, p < .001$ . Health self-efficacy in exercise was significantly predictive of physical activities ( $p < .001$ ); health motivation measured by personal strivings was also a significant predictor of physical activities ( $p < .05$ ).

When males were examined, the overall indices of multiple regression to predict physical activities from BMI, health value, health self-efficacy, and health motivation ranking,  $R = .47$  and  $R^2 = .22$ . That is, when all the five variables were used as predictors, about 22% of the variances in physical activities could be predicted. The adjusted  $R^2$  was .19. The overall regression was statistically significant,  $F(4, 94) = 6.62, p < .001$ . Only self-efficacy in physical activities statistically significantly predicted physical activities. The predictive equation was as follows:

Physical Activities =  $(-8235.79) + 64.81 * \text{BMI} + 159.60 * \text{Health value} + 444.29 * \text{self-efficacy} + 159.13 * \text{Health motivation}$ .

When females were examined, the overall indices of multiple regression to predict physical activities from BMI, health value, health self-efficacy, and health motivation ranking,  $R = .20$  and  $R^2 = .04$ . That is, when all the five variables were used as predictors, about 4% of the variances in physical activities could be predicted. The adjusted  $R^2$  was .01. The overall regression was not statistically significant,  $F(4, 149) = 1.51, p = .20$ . No single predictor that statistically predicted physical activities was found either.

#### *Predicting Healthy Eating Behaviors*

*Using the scores obtained by the motivation ranking scale.* When using the ranking of health motivation among 16 motives as a predictor instead of health motivation in food choice behaviors, the overall indices of multiple regression,  $R = .52$  and  $R^2 = .27$ . That is, when all the four variables were used as predictors, about 27% of the variances in food choice behaviors could be predicted. The adjusted  $R^2$  was .26. The overall regression was statistically significant,  $F(4, 245) = 22.60, p < .001$ . Health self-efficacy in nutrition and

the ranking of health motivation were both significantly predictive of food choice behaviors ( $p < .001$ ).

When males were examined, the overall indices of multiple regression to predict healthy eating behaviors from BMI, health value, health self-efficacy, and health motivation,  $R = .56$  and  $R^2 = .31$ . That is, when all the four variables were used as predictors, about 31% of the variances in healthy eating behaviors could be predicted. The adjusted  $R^2$  was .28. The overall regression was statistically significant,  $F(4, 93) = 10.35, p < .001$ . Only health self-efficacy in nutrition statistically significantly predicted food choice, but not the ranking of the health motivation. The predictive equation was as follows:

Food Habits = .93 + .06 \* BMI + .02 \* Health value + .64 \* self-efficacy + (-.23) \* Health motivation.

When females were examined, the overall indices of multiple regression to predict healthy eating behaviors from BMI, health value, health self-efficacy, and health motivation,  $R = .51$  and  $R^2 = .26$ . That is, when all the four variables were used as predictors, about 26% of the variances in healthy eating behaviors could be predicted. The adjusted  $R^2$  was .24. The overall regression was statistically significant,  $F(4, 142) = 12.33, p < .001$ . Health self-efficacy in nutrition ( $p < .001$ ) statistically and health motivation ranking ( $p = .027$ ) significantly predicted food choice. The predictive equation was as follows:

Food Habits = 7.01 + (-.10) \* BMI + .12 \* Health value + .49 \* self-efficacy + (-.27) \* Health motivation.



*Using the scores of the health motivation measured by personal strivings.* When using health motivation measured by personal strivings as a predictor in place of health motivation in food choice behaviors, the overall indices of multiple regression,  $R = .51$  and  $R^2 = .26$ . The adjusted  $R^2$  was .25. The overall regression was statistically significant,  $F(4, 246) = 21.74, p < .001$ . Health self-efficacy in nutrition was significantly predictive of food choice behaviors ( $p < .001$ ); the health motivation measured by personal strivings ( $p = .017$ ) and health value ( $p = .03$ ) were also significant predictors of food choice behaviors.

When males were examined, the overall indices of multiple regression to predict healthy eating behaviors from the same four predictors,  $R = .58$  and  $R^2 = .33$ . That is, when all the four variables were used as predictors, about 33% of the variances in healthy eating behaviors could be predicted. The adjusted  $R^2$  was .30. The overall regression was statistically significant,  $F(4, 93) = 11.51, p < .001$ . Health self-efficacy in nutrition ( $p < .001$ ) and health motivation measured by personal strivings ( $p = .015$ ) statistically significantly predicted food choice. The predictive equation was as follows:

Food Habits = (-2.96) + .07 \* BMI + .07 \* Health value + .63 \* self-efficacy + .19 \* Health motivation.

When females were examined, the overall indices of multiple regression to predict healthy eating behaviors from BMI, health value, health self-efficacy, and health motivation,  $R = .50$  and  $R^2 = .25$ . That is, when all the four variables were used as predictors, about 25% of the variances in healthy eating behaviors could be predicted. The adjusted  $R^2$  was .22. The overall regression was statistically significant,  $F(4, 143) =$

11.59,  $p < .001$ . Health self-efficacy in nutrition ( $p < .001$ ) and health value ( $p = .016$ ) statistically significantly predicted food choice. The predictive equation was as follows:  
Food Habits = 2.94 + (-.11) \* BMI + .20 \* Health value + .52 \* self-efficacy + .10 \* Health motivation.

*When Using the Scores Obtained by Health Value Ranking Scale*

*Predicting Physical Activities*

*All participants included.* In the above series of analyses, health value was measured by the four-item scales introduced in the method section. The following analyses used the scores obtained by health value ranking scale instead of the four-item scale scores. When the BMI, health value ranking, self-efficacy in exercise, health motivation measured by personal strivings were predictors of physical activities, the overall indices of multiple regression,  $R = .31$  and  $R^2 = .10$ . That is, when all the four variables were used as predictors, about 10% of the variances in healthy eating behaviors could be predicted. The adjusted  $R^2$  was .08. The overall regression was statistically significant,  $F(4, 253) = 6.64$ ,  $p < .001$ . Health self-efficacy in exercise ( $p < .001$ ) and health motivation measured by personal strivings ( $p = .019$ ) were significantly predictive of physical activities, but not health value ranking.

*Only for males.* When males were examined, the overall indices of multiple regression to predict physical activities from BMI, health value ranking, health self-efficacy, and health motivation measured by personal strivings,  $R = .45$  and  $R^2 = .20$ . That is, when all the five variables were used as predictors, about 20% of the variances in physical activities could be predicted. The adjusted  $R^2$  was .16. The overall regression

was statistically significant,  $F(4, 95) = 5.86, p < .001$ . Self-efficacy in physical activities ( $p < .001$ ) and health motivation measured by personal strivings ( $p = .048$ ) statistically significantly predicted physical activities. The predictive equation was as follows:

Physical Activities =  $(-2535.64) + (-35.09) * \text{BMI} + (-59.73) * \text{Health value} + 427.10 * \text{self-efficacy} + 176.15 * \text{Health motivation}$ .

*Only for females.* When females were examined, the overall indices of multiple regression to predict physical activities from BMI, health value ranking, health self-efficacy, and health motivation measured by personal strivings,  $R = .21$  and  $R^2 = .04$ . That is, when all the five variables were used as predictors, about 4% of the variances in physical activities could be predicted. The adjusted  $R^2$  was .02. The overall regression was not statistically significant,  $F(4, 148) = 1.66, p = .162$ . No single predictor that statistically predicted physical activities was found either.

#### *Predicting Healthy Eating Behaviors*

*All participants included.* When using health value ranking instead of the four-item scale scores, health motivation measured by personal strivings, self-efficacy in nutrition, and BMI as predictors of healthy eating, the overall indices of multiple regression,  $R = .52$  and  $R^2 = .27$ . That is, when all the five variables were used as predictors, about 27% of the variances in physical activities could be predicted. The adjusted  $R^2$  was .26. The overall regression was statistically significant,  $F(4, 246) = 22.66, p < .001$ . The health value ranking, health self-efficacy in nutrition, and health motivation measured by personal strivings were all significantly predictive of food choice behaviors. The predictive equation was as follows:

Healthy Eating Behaviors = 6.27 + (-.08) \* BMI + (-.22) \* Health value + .54 \* self-efficacy + .12 \* Health motivation.

*Only for males.* When males were examined, the overall indices of multiple regression to predict healthy eating behaviors from BMI, health value, health self-efficacy, and health motivation measured by personal strivings,  $R = .60$  and  $R^2 = .35$ . That is, when all the five variables were used as predictors, about 35% of the variances in healthy eating behaviors could be predicted. The adjusted  $R^2$  was .33. The overall regression was statistically significant,  $F(4, 94) = 12.88, p < .001$ . Health value ranking ( $p = .018$ ), self-efficacy in nutrition ( $p < .001$ ), and health motivation measured by personal strivings ( $p = .025$ ) significantly predicted healthy eating behaviors. The predictive equation was as follows:

Healthy Eating Behaviors = 3.37 + (-.04) \* BMI + (-.28) \* Health value + .60 \* self-efficacy + .18 \* Health motivation.

*Only for females.* When females were examined, the overall indices of multiple regression to predict healthy eating behaviors from BMI, health value, health self-efficacy, and health motivation measured by personal strivings,  $R = .48$  and  $R^2 = .23$ . That is, when all the five variables were used as predictors, about 23% of the variances in healthy eating behaviors could be predicted. The adjusted  $R^2$  was .21. The overall regression was statistically significant,  $F(4, 142) = 10.72, p < .001$ . Only self-efficacy in nutrition ( $p < .001$ ) significantly predicted healthy eating behaviors. The predictive equation was as follows:

Healthy Eating Behaviors = 8.33 + (-.12) \* BMI + (-.19) \* Health value + .50 \* self-

efficacy + .08 \* Health motivation.

*When Using the Scores Obtained by Health Value Ranking Scale and the Two Health Motivation Scales*

*Predicting Physical Activities*

*Using HMS-PA model 1.* When using health value ranking instead of the four-item scale scores, health motivation measured by the HMS-PA Model 1, self-efficacy in exercise, and BMI as predictors of physical activities, the overall indices of multiple regression,  $R = .36$  and  $R^2 = .13$ . That is, when all the five variables were used as predictors, about 13% of the variances in healthy eating behaviors could be predicted. The adjusted  $R^2$  was .12. The overall regression was statistically significant,  $F(4, 241) = 9.16, p < .001$ . Health motivation ( $p < .001$ ) was significantly predictive of physical activities, but not health value ranking. The predictive equation was as follows:

Physical Activities =  $1803.85 + (-36.21) * \text{BMI} + (-27.89) * \text{Health value} + 144.41 * \text{self-efficacy} + 68.10 * \text{Health motivation}$ .

When males were examined, the overall indices of multiple regression to predict physical activities from BMI, health value ranking, health self-efficacy, and health motivation measured by the HMS-PA Model 1,  $R = .47$  and  $R^2 = .22$ . That is, when all the five variables were used as predictors, about 22% of the variances in physical activities could be predicted. The adjusted  $R^2$  was .18. The overall regression was statistically significant,  $F(4, 92) = 6.39, p < .001$ . Self-efficacy in exercise statistically ( $p = .025$ ) and health motivation ( $p = .036$ ) significantly predicted physical activities. The predictive equation was as follows:

Physical Activities = (-240.48) + (-88.08) \* BMI + (-60.41) \* Health value + 352.95 \* self-efficacy + 63.16 \* Health motivation.

When females were examined, the overall indices of multiple regression to predict physical activities from BMI, health value ranking, health self-efficacy, and health motivation measured by the HMS-PA Model 1,  $R = .29$  and  $R^2 = .09$ . That is, when all the five variables were used as predictors, about 9% of the variances in physical activities could be predicted. The adjusted  $R^2$  was .06. The overall regression was statistically significant,  $F(4, 141) = 3.34, p = .012$ . Only health motivation statistically significantly predicted physical activities ( $p = .009$ ). The predictive equation was as follows:

Physical Activities = 3455.85 + (-38.01) \* BMI + (-21.73) \* Health value + 46.29 \* self-efficacy + 63.46 \* Health motivation.

*Using HMS-PA model 2.* When using health value ranking instead of the four-item scale scores, health motivation measured by the HMS-PA Model 2, self-efficacy in exercise, and BMI as predictors of physical activities, the overall indices of multiple regression,  $R = .36$  and  $R^2 = .13$ . That is, when all the five variables were used as predictors, about 13% of the variances in healthy eating behaviors could be predicted. The adjusted  $R^2$  was .12. The overall regression was statistically significant,  $F(4, 246) = 9.40, p < .001$ . Health motivation ( $p < .001$ ) was significantly predictive of physical activities, but not health value ranking. The predictive equation was as follows:

Physical Activities = 1682.69 + (-37.78) \* BMI + (-33.47) \* Health value + 159.91 \* self-efficacy + 150.03 \* Health motivation.

When males were examined, the overall indices of multiple regression to predict

physical activities from BMI, health value ranking, health self-efficacy, and health motivation measured by the HMS-PA Model 2,  $R = .47$  and  $R^2 = .22$ . That is, when all the five variables were used as predictors, about 22% of the variances in physical activities could be predicted. The adjusted  $R^2$  was .19. The overall regression was statistically significant,  $F(4, 94) = 6.56, p < .001$ . Self-efficacy in exercise statistically ( $p = .014$ ) and health motivation ( $p = .032$ ) significantly predicted physical activities. The predictive equation was as follows:

Physical Activities =  $(-466.11) + (-83.37) * \text{BMI} + (-68.59) * \text{Health value} + 369.52 * \text{self-efficacy} + 139.11 * \text{Health motivation}$ .

When females were examined, the overall indices of multiple regression to predict physical activities from BMI, health value ranking, health self-efficacy, and health motivation measured by the HMS-PA Model 2,  $R = .30$  and  $R^2 = .09$ . That is, when all the five variables were used as predictors, about 9% of the variances in physical activities could be predicted. The adjusted  $R^2$  was .06. The overall regression was statistically significant,  $F(4, 143) = 3.41, p = .011$ . Only health motivation statistically significantly predicted physical activities ( $p = .008$ ). The predictive equation was as follows:

Physical Activities =  $3576.84 + (-45.86) * \text{BMI} + (-21.58) * \text{Health value} + 50.83 * \text{self-efficacy} + 144.16 * \text{Health motivation}$ .

*Using HMS-PA model 3.* When using health value ranking instead of the four-item scale scores, health motivation measured by the HMS-PA Model 3, self-efficacy in exercise, and BMI as predictors of physical activities, the overall indices of multiple regression,  $R = .35$  and  $R^2 = .12$ . The adjusted  $R^2$  was .11. The overall regression was

statistically significant,  $F(4, 246) = 8.59, p < .001$ . Health self-efficacy in exercise ( $p = .041$ ) and health motivation measured by HMS-PA model 3 ( $p = .001$ ) were significantly predictive of physical activities, but not health value ranking. The predictive equation was as follows:

Physical Activities =  $1485.55 + (-36.32) * \text{BMI} + (-40.17) * \text{Health value} + 172.06 * \text{self-efficacy} + 106.49 * \text{Health motivation}$ .

When males were examined, the overall indices of multiple regression to predict physical activities from BMI, health value ranking, health self-efficacy, and health motivation measured by the HMS-PA Model 3,  $R = .46$  and  $R^2 = .21$ . That is, when all the five variables were used as predictors, about 21% of the variances in physical activities could be predicted. The adjusted  $R^2$  was .18. The overall regression was statistically significant,  $F(4, 94) = 6.18, p < .001$ . Self-efficacy in exercise statistically ( $p = .012$ ) significantly predicted physical activities. The predictive equation was as follows: Physical Activities =  $(-709.82) + (-82.22) * \text{BMI} + (-75.35) * \text{Health value} + 385.66 * \text{self-efficacy} + 97.07 * \text{Health motivation}$ .

When females were examined, the overall indices of multiple regression to predict physical activities from BMI, health value ranking, health self-efficacy, and health motivation measured by the HMS-PA Model 3,  $R = .28$  and  $R^2 = .08$ . That is, when all the five variables were used as predictors, about 8% of the variances in physical activities could be predicted. The adjusted  $R^2$  was .05. The overall regression was statistically significant,  $F(4, 143) = 3.00, p = .021$ . Only health motivation statistically significantly predicted physical activities ( $p = .019$ ). The predictive equation was as follows:



Physical Activities = 3416.59 + (-44.26) \* BMI + (-29.25) \* Health value + 61.55 \* self-efficacy + 101.69 \* Health motivation.

*Predicting Healthy Eating Behaviors*

*Using HMS-HE model 1.* When using health value ranking instead of the four-item scale scores, health motivation measured by the HMS-HE Model 1, self-efficacy in nutrition, and BMI as predictors of food choice behaviors, the overall indices of multiple regression,  $R = .74$  and  $R^2 = .55$ . That is, when all the five variables were used as predictors, about 55% of the variances in physical activities could be predicted. The adjusted  $R^2$  was .54. The overall regression was statistically significant,  $F(4, 242) = 72.48, p < .001$ . The health value ranking ( $p = .031$ ), health self-efficacy in nutrition ( $p = .007$ ), and health motivation ( $p < .001$ ) were all significantly predictive of food choice behaviors. The predictive equation was as follows:

Healthy Eating Behaviors = 8.33 + (-.04) \* BMI + (-.13) \* Health value + .17 \* self-efficacy + .15 \* Health motivation.

When males were investigated, the overall indices of multiple regression to predict healthy eating behaviors from BMI, health value ranking, health self-efficacy, and health motivation measured by the HMS-HE Model 1,  $R = .79$  and  $R^2 = .62$ . That is, when all the five variables were used as predictors, about 62% of the variances in healthy eating behaviors could be predicted. The adjusted  $R^2$  was .60. The overall regression was statistically significant,  $F(4, 93) = 37.49, p < .001$ . Self-efficacy ( $p = .007$ ) and health motivation measured by the HMS-HE Model 1 ( $p < .001$ ) significantly predicted healthy eating behaviors. The predictive equation was as follows:

Healthy Eating Behaviors = 8.16 + (-.09) \* BMI + (-.16) \* Health value + .25 \* self-efficacy + .14 \* Health motivation.

When females were investigated, the overall indices of multiple regression to predict healthy eating behaviors from BMI, health value, health self-efficacy, and health motivation measured by the HMS-HE Model 1,  $R = .71$  and  $R^2 = .51$ . That is, when all the five variables were used as predictors, about 51% of the variances in healthy eating behaviors could be predicted. The adjusted  $R^2$  was .50. The overall regression was statistically significant,  $F(4, 139) = 36.78, p < .001$ . Only health motivation measured by the HMS-HE Model 1 ( $p < .001$ ) significantly predicted healthy eating behaviors. The predictive equation was as follows:

Healthy Eating Behaviors = 7.86 + .02 \* BMI + (-.12) \* Health value + .11 \* self-efficacy + .17 \* Health motivation.

*Using HMS-HE model 2.* When using health value ranking instead of the four-item scale scores, health motivation measured by the HMS-HE Model 2, self-efficacy in nutrition, and BMI as predictors of food choice behaviors, the overall indices of multiple regression,  $R = .74$  and  $R^2 = .54$ . That is, when all the five variables were used as predictors, about 54% of the variances in physical activities could be predicted. The adjusted  $R^2$  was .53. The overall regression was statistically significant,  $F(4, 244) = 71.73, p < .001$ . The health value ranking ( $p = .023$ ), health self-efficacy in nutrition ( $p = .001$ ), and health motivation ( $p < .001$ ) were all significantly predictive of food choice behaviors. The predictive equation was as follows:

Healthy Eating Behaviors = 8.07 + (-.06) \* BMI + (-.14) \* Health value + .21 \* self-

efficacy + .36 \* Health motivation.

When males were investigated, the overall indices of multiple regression to predict healthy eating behaviors from BMI, health value ranking, health self-efficacy, and health motivation measured by the HMS-HE Model 2,  $R = .79$  and  $R^2 = .62$ . That is, when all the five variables were used as predictors, about 62% of the variances in healthy eating behaviors could be predicted. The adjusted  $R^2$  was .61. The overall regression was statistically significant,  $F(4, 93) = 38.63, p < .001$ . Self-efficacy ( $p = .002$ ) and health motivation measured by the HMS-HE Model 2 ( $p < .001$ ) significantly predicted healthy eating behaviors. The predictive equation was as follows:

Healthy Eating Behaviors =  $8.34 + (-.12) * \text{BMI} + (-.17) * \text{Health value} + .28 * \text{self-}$   
efficacy +  $.34 * \text{Health motivation}$ .

When females were investigated, the overall indices of multiple regression to predict healthy eating behaviors from BMI, health value, health self-efficacy, and health motivation measured by the HMS-HE Model 2,  $R = .71$  and  $R^2 = .50$ . That is, when all the five variables were used as predictors, about 50% of the variances in healthy eating behaviors could be predicted. The adjusted  $R^2$  was .48. The overall regression was statistically significant,  $F(4, 141) = 34.86, p < .001$ . Only health motivation measured by the HMS-HE Model 2 ( $p < .001$ ) significantly predicted healthy eating behaviors. The predictive equation was as follows:

Healthy Eating Behaviors =  $7.22 + .01 * \text{BMI} + (-.12) * \text{Health value} + .16 * \text{self-}$   
efficacy +  $.39 * \text{Health motivation}$ .

*Using HMS-HE model 3.* When using health value ranking instead of the four-item

scale scores, health motivation measured by the HMS-HE Model 3, self-efficacy in nutrition, and BMI as predictors of food choice behaviors, the overall indices of multiple regression,  $R = .74$  and  $R^2 = .55$ . That is, when all the five variables were used as predictors, about 55% of the variances in physical activities could be predicted. The adjusted  $R^2$  was .54. The overall regression was statistically significant,  $F(4, 244) = 73.70, p < .001$ . The health value ranking ( $p = .021$ ), health self-efficacy in nutrition ( $p = .006$ ), and health motivation ( $p < .001$ ) were all significantly predictive of food choice behaviors. The predictive equation was as follows:

Healthy Eating Behaviors =  $8.47 + (-.04) * \text{BMI} + (-.14) * \text{Health value} + .18 * \text{self-efficacy} + .29 * \text{Health motivation}$ .

When males were investigated, the overall indices of multiple regression to predict healthy eating behaviors from BMI, health value ranking, health self-efficacy, and health motivation measured by the HMS-HE Model 3,  $R = .79$  and  $R^2 = .62$ . That is, when all the five variables were used as predictors, about 62% of the variances in healthy eating behaviors could be predicted. The adjusted  $R^2$  was .60. The overall regression was statistically significant,  $F(4, 93) = 37.87, p < .001$ . Self-efficacy ( $p = .006$ ) and health motivation measured by the HMS-HE Model 3 ( $p < .001$ ) significantly predicted healthy eating behaviors. The predictive equation was as follows:

Healthy Eating Behaviors =  $8.07 + (-.09) * \text{BMI} + (-.16) * \text{Health value} + .26 * \text{self-efficacy} + .26 * \text{Health motivation}$ .

When females were investigated, the overall indices of multiple regression to predict healthy eating behaviors from the same four predictors,  $R = .72$  and  $R^2 = .52$ . That is,

when all the five variables were used as predictors, about 52% of the variances in healthy eating behaviors could be predicted. The adjusted  $R^2$  was .50. The overall regression was statistically significant,  $F(4, 141) = 37.58, p < .001$ . Only health motivation ( $p < .001$ ) significantly predicted healthy eating behaviors. The predictive equation was as follows:

$$\text{Healthy Eating Behaviors} = 8.10 + .02 * \text{BMI} + (-.13) * \text{Health value} + .11 * \text{self-} \\ \text{efficacy} + .31 * \text{Health motivation}.$$

## CHAPTER 6

### CONCLUSION AND DISCUSSION

The purposes of this dissertation project were set out to propose a theoretical model of health motivation, to develop health motivation scales in physical activities (HMS-PA) and healthy eating (HMS-HE) based upon this model, to test the construct and discriminant validity of the scores obtained using these two scales, and to examine the predictive power of this model in terms of daily physical activities and healthy eating behaviors.

#### The Construct Validity of the Scores Obtained by the Two Health Motivation Scales

To examine the construct validity of the scores obtained by the two self-developed health motivation scales, different approaches were applied. In Study 1, the construct validities of the scores of the three models of HMS-PA and the three models of HMS-HE by using exploratory factor analyses. As shown in Study 1, the scores of the HMS-PA Model 1 and HMS-HE Model 1 roughly exhibited the theoretical construct of health motivation. When the items with low loadings or double loadings or irrational loadings were deleted, the scores of the HMS-PA Model 2 and 3 and HMS-HE Model 2 and 3 demonstrated the theoretical models better than the full scales. However, further investigations are needed for few items, for example the HI6, PM4, and PM3 of the HMS-PA and the HMT1 of the HMS-HE.

In Study 2, the construct validities of the scores obtained by the three models of HMS-PA and three models of HMS-HE were investigated by using higher order

confirmatory factor analyses. The results indicated that the HMS-PA Model 2 fit the data better than the other two models of HMS-PA, and that the HMS-HE Model 3 fit the data better than the other two models. However, the item AIM3 of HMS-HE Model 3 should be considered to be deleted or reworded in future studies because it loaded on two factors. However, the HMS-HE was a three-factor model, which was different from the originally proposed theoretical model. To test whether the four-factor better fit the data of the HMS-HE model 2, the higher order confirmatory factor analysis was conducted. The results supported this four-factor model. It was the best fit among all the HMS-HE models.

In Study 1, four tests were conducted to determine the number of factors. Almost all of the tests indicated one factor for all the three models of the two scales. Therefore, the one factor models were tested in Study 2. The findings suggested that the one factor models fit the data poorly. However, the other four-factor models have two levels, and the four factors on the first level converge to the factor of health motivation on the second level. This may correspond to the one factor suggested by the four factor number determining tests, although the confirmatory factor analysis did not support the one-factor models. Considering the findings of the higher order confirmatory factor analyses for four factors, generally speaking, the results of the confirmatory factor analyses marginally supported the four-factor health motivation model. More analyses are needed to further determine the proposed theoretical health motivation model.

## Discriminant Validity

The health motivation defined in the HMS-PA and HMS-HE were supposed to be different from what suggested in HSDI and SMI, although it was claimed that the later two scales aimed to measure health motivation. The close to zero linear correlations between the scores of the three models of HMS-PA and HMS-HE and those of HSDI and SMI and no apparent quadratic relationships indicated that the HMS-PA and HMS-HE models were very different from HSDI and SMI. When analyzing their construct, the HSDI was based upon the self-determination theory that focuses on intrinsic motivation and extrinsic motivation. The SMI was based upon the traditional understanding of motivation. They are indeed very different from the proposed four-factor structure.

## Predictive Validity

To comprehensively test the predictive power of the HMS-PA and HMS-HE, different measurement approaches were applied to Study 2. For instance, self-judgment scales (HMS-PA and HMS-HE), a ranking scale (motivation ranking scale), and a semi-thematic measure (Revised Striving Assessment) were used to measure health motivation. In addition, two measurement approaches were applied to assess health value (a four-item self-judgment scale and Rokeach's value ranking scale).

### *Full Length Health Motivation Scales vs. Their Shortened Versions*

The three models of HMS-PA were statistically significantly predictive of physical activities measured by the Global Physical Activity Questionnaire (GPAQ). The HMS-HE models statistically significantly predicted food habits measured by the Adolescent



Food Habits Checklist (AFHC). These findings indicated that although the scores of HMS-PA Model 1 displayed much worse construct validity than those of the other two models of HMS-PA, they did show similar level of predictive power. This was also true to HMS-HE models. It was expected that HMS-PA Model 1 and HMS-HE Model 1 were less predictive than the other models because of the lower construct validity of its scores. However, the fact was that they did show predictive power. This may be because the desirable internal consistencies of these two models.

#### *The Predictive Power of the Scores of the Other Measures*

The health motivation was measured by a ranking scale, which includes 16 motives in total. However, the ranking of health motivation did not predict physical activities. When health motivation was measured by personal strivings, it was statistically significantly predictive of physical activities. Nevertheless, when food choice behaviors were being predicted, both health motivation ranking and that of being measured by personal strivings were statistically significant predictors. Similarly, the ranking of health value was not statistically significantly predictive of physical activities when predicting physical activities, but it was a statistically significant predictor of food choice behaviors. These findings suggested that the health motivation measured by personal strivings was a good predictor of healthy behaviors, including physical activities and food choice behaviors. However, the predictive power of the ranking of health motivation or health value was mixed. This may be due to the construct the measurements intend to measure. The personal strivings are claimed to measure the action aspect of motivation, which corresponds to the action initiation factor of the proposed health motivation model. This

aspect is closely related to actual behaviors. Therefore, personal strivings are predictive of behaviors. However, for the ranking of health motivation, it just represents its relative importance among other motivations. Even it is highly important, individuals may not actually take actions. Maybe this is why it was not predictive of healthy behaviors.

### The Process Model of Health Motivation

The proposed definition and theoretical model of health motivation and the scales based upon this model are the first attempt to systematically study health motivation. The four components of this theoretical model involve both health motivation initiation (e.g., forming health motivation tendency) and its involving in the process of health-related goal fulfillment, for example being motivated to take action to achieve the pre-set goals, (e.g., health intention and health action initiation) and being driven to persist in the initiated actions in order to accomplish the health-related goals (e.g., persistency motivation). As discussed in the background section, motivation is a goal oriented inner process with sequential stages. This first comprehensive model embodies such sequential process and it does advance the field of health motivation.

This process model of health motivation is more comprehensive and advanced than other constructs. For instance, the construct of health motivation measured by Personal Striving Assessment focuses only on the action aspect of health motivation, not including the process of forming health motivation intention and the process of being motivated to persist in health related actions. Further, health motivation ranking focuses only on the relative importance of health motivation, not involving any health motivation related

internal processes. Maybe that is why health motivation was a more powerful predictor of physical activities and healthy eating in the present study. Also, as reviewed in a previous section, health motivation was often measured using one-item scales. Only one-item cannot effectively capture the complicated construct of health motivation.

#### Health Motivation, Health Self-efficacy, Health Value, and BMI

Previous studies showed that health value played a role in health behaviors (e.g., Kaplan & Cowles, 1978; Wurtele, Britcher, & Saslawsky, 1985). For example, Kaplan and Cowles (1978) demonstrated that people who highly valued health were most successful in achieving and maintaining their reduction in smoking. Other studies suggested that health value was not a good predictor of health behaviors. For instance, it was found that health value was not significantly associated with safe belt use (Riccio-Howe, 1991). However, the present study did not favor health value. Although the ranking scores of health values was statistically significantly predict food habits, the scores of the four-item health value scale were not predictive of either physical activities or food choice behaviors, nor were the ranking scores predictive of physical activities.

It has been shown that BMI is associated with health behaviors. For instance, Liebman et al. (2003) suggested that the higher BMI, the higher likelihood to drink sweetened beverages and less likely to eat high-fiber cereal or breakfast with family. Therefore, it was expected that BMI was associated with people's health related behaviors and its predictive power was tested in the present study. However, it turned out that the predictive power of BMI in physical activities or healthy eating was not

statistically significant.

As discussed in the background section, health self-efficacy has been repeatedly testified to be the most powerful predictor of healthy behaviors in previous studies. The present study confirmed such conclusion again. It has also been shown that health motivation is a good predictor of health behaviors, which can be concluded from current study, as well, although the ranking of health motivation was not a significant predictor of physical activities. Therefore, it can be concluded that health motivation and health self-efficacy are better predictors of physical activities or healthy eating than health value and BMI. When their explained variances being compared, health motivation accounted for more variances than health self-efficacy did, which indicated that health motivation may have stronger predictive power than health self-efficacy.

#### Gender Effects

When females and males were compared in terms of their physical activities and healthy eating behaviors, there were statistically significant differences. Males statistically significantly performed more physical activities than females, whereas females statistically significantly practiced more healthy eating behaviors than males. When the predictive powers of BMI, health value, health self-efficacy, and health motivation in physical activities were examined among males and females respectively, health self-efficacy was a strong predictor of physical activities among males, whereas health motivation was strongly predictive of physical activities among females. However, when the predictive powers of the same variables were investigated among males and

females respectively, self-efficacy was not statistically significantly predictive of health eating among females only when HMS-HE Model 1 was used. The same gender differences did appear when other HMS-HE Models were applied. Such differences may be contributed to different reasons. Firstly, the society values muscular males. Physical activities can help them to build their muscles and make them strong. However, healthy eating may not be as helpful as physical activities do in terms of being muscular. On the contrary, because males exercise more, they consume more and need more food. Therefore, it is reasonable that they perform less healthy eating than females. Secondly, for females, restricting on food intake can help them to maintain or improve their figure. They do not have to engage in physical activities to have a good figure. Furthermore, exercises are always more time consuming than engaging in healthy eating. Therefore, they work out less than males.

### Conclusion

In conclusion, the proposed theoretical model of health motivation was marginally supported by the results from several statistical tests conducted on the scores obtained using health motivation scales (HMS-PA and HMS-HE) that were based upon the theoretical model. Among the three models of HMS-PA, both exploratory factor analysis and confirmatory factor analysis suggested that the HMS-PA Model 2 fit the data better than the other two models. Both exploratory factor analysis and confirmatory factor analysis indicated that the HMS-HE Model 3 fit the data better than the other two models. However, these two models just marginally fit the data according to the confirmatory

factor analysis. However, the four-factor model of HMS-HE Model 2 fit the data very well, which supported the proposed theoretical model. The close to zero correlations between the scores of the HMS-PA and HMS-HE and those of HSDI and SMI indicated that the two newly developed scales were very different from the latter two scales. Also, health motivation exhibited strong predictive power in terms of physical activities and food choice behaviors, but there were gender differences.

However, there are limitations in this study. For example, the participants involved in the present study were college students only. In future studies, this model should be tested among other populations (e.g., elder individuals). Besides the four variables (health motivation, health self-efficacy, BMI, and health value), there are other factors that may affect individuals' healthy behaviors such as social economic status, previous experiences with illness, and the knowledge about health. These factors may be considered in future studies. This studies discussed gender differences, but for people who have different BMI, may behave differently too. This should also be considered in the future too. This study focused on physical activities and healthy eating only. Whether health motivation affects other healthy behaviors, for instance, personal hygiene and safe sexual behavior needs to be studied as well.

Taken together, these findings suggest the effectiveness of the proposed theoretical model of health motivation, and suggest that the HMS-PA Model 2 and HMS-HE Model 3 can be applied to both theoretical and empirical studies. I hope that this proposed definition and theoretical model of health motivation bring a new view to people, and that this definition and theoretical model contribute to the field of motivation.

## APPENDIX I

### THE TWO HEALTH MOTIVATION SCALES

#### Health Motivation Scale in Physical Activities

##### **Instructions:**

In the following section you will find a series of statements that are used to describe your physical activities. Physical activities mentioned here include a broad range of behaviors, for example, exercise, fitness, swim, run, jog, walk, play basketball, etc. Please carefully read each statement and decide to what extent it describes you on a 5-point scale, ranging from -2 “extremely not like me”, -1 “somewhat not like me”, 0 “neutral”, 1 “somewhat like me”, to 2 “extremely like me”. Please circle the corresponding number after you make your judgment. Please note that your responses are anonymous and for research purpose only; there are no good or bad answers; just be honest and objective.

##### **Items:**

###### **Health motivational tendency**

1. I tend to engage in physical activities to be healthy.
2. I intend to perform physical activities to be healthy.
3. I desire to perform physical activities to be healthy.
4. I am motivated to perform physical activities to be healthy.
5. I do not have the desire to perform physical activities to be healthy.
6. I do not have the motivation to engage in physical activities to be healthy.
7. I wish to be healthy through performing physical activities.
8. I have the need to perform physical activities to be healthy.
9. My intention of being healthy through physical activities is strong.

###### **Health intention**

1. I plan to perform physical activities because I want to be healthy.
2. I do not have any plan to perform physical activities to be healthy.
3. I never think to perform physical activities to be healthy.
4. I do not have the intention to perform physical activities for the purpose of being healthy.
5. To be healthy, I plan to perform physical activities regularly.
6. I do not intend to perform physical activities for the purpose of being healthy.

###### **Action initiation motivation**

1. Although I have the desire to be healthy, I do not think I will initiate any physical activities to satisfy my desire.
2. If I decide to be healthy through physical activities, I will take actions to reach my health related goals.
3. I may not perform physical activities, although I want to be healthy.
4. I will start to engage in physical activities if I want to be healthy.

5. I will initiate physical activities if I want to be healthy.
6. For the purpose of being healthy, I will make a physical activity plan.
7. To be healthy, I try to make physical activity plans.

**Persistence motivation (Volition)**

1. I can persist in physical activities because I want to be healthy.
2. I can engage in physical activities over a long period of time for the purpose of being healthy.
3. If I decided to engage in physical activities to be healthy, no matter what happens, I can stick to my plan.
4. Even if I wanted to be healthy through physical activities, I don't think I can do it for a long time.
5. I do not think I will stick to a long-term physical activity plan for the purpose of being healthy.
6. If I have strong motivation to be healthy through physical activities, I think I can be persistent in these activities.
7. I would persist in my physical activities for a long time to be healthy.
8. If I planned to perform physical activities to be healthy and I actually started my plan, I won't stop it easily.



## Health Motivation Scale in Healthy Eating

### **Instructions:**

In the following section you will find a series of statements that are used to describe your eating style. Healthy eating here refers to having food which is healthy or nutrition balanced such as fruit, vegetable, low fat food, low calorie food, whole grains, milk and other dairy, food with protein (e.g., fish, egg, beans, peas, nuts, seeds, or meat), etc. Please carefully read each statement and make judgments about to what extent it describes you on a 5-point scale, ranging from -2 “extremely not like me”, -1 “somewhat not like me”, 0 “neutral”, 1 “somewhat like me”, to 2 “extremely like me”. Please circle the corresponding number after you make your judgment. Please note that your responses are anonymous and for research purpose only; there are no good or bad answers; just be honest and objective.

### **Items:**

#### **Health motivational tendency**

1. I tend to eat healthily for the purpose of being healthy.
2. I desire to eat healthily for the purpose of being healthy.
3. I have the motivation to eat healthily for the purpose of being healthy.
4. I do not have the desire to eat healthily.
5. I do not have the motivation to eat healthily.
6. I am motivated to eat healthily because I want to be healthy.
7. I need to eat healthily for the purpose of being healthy.
8. I may not eat healthily, although I want to be healthy.

#### **Health intention/plan**

1. I plan to eat healthily because I want to be healthy.
2. I do not have any plan to eat healthily.
3. I have the intention to eat healthily for the purpose of being healthy.
4. I do not have any intention to eat healthily.
5. I plan to eat healthy food more often because I want to be healthy.
6. I do not intend to eat healthily.
7. I don't care whether I eat healthily or not.

#### **Action initiation motivation**

1. If my intention of being healthy through healthy eating is strong enough, I will eat healthily.
2. Although I have the desire to be healthy, I do not think I will eat healthily.
3. If I decide to eat healthily for the purpose of being healthy, I will do that to reach my goals.
4. I will start to engage in healthy eating if I want to be healthy.
5. I will initiate healthy eating if I want to be healthy.
6. For the purpose of being healthy, I will make a healthy eating plan.
7. I try to make healthy eating plans because I want to be healthy.

**Persistence motivation (Volition)**

1. I can persist in healthy eating because I want to be healthy.
2. I can engage in healthy eating over a long period of time for the purpose of being healthy.
3. If I decided to engage in healthy eating to be healthy, no matter what happens, I can stick to my plan.
4. Even if I wanted to be healthy through healthy eating, I don't think I can do it for a long time.
5. I do not think I will stick to a long-term healthy eating plan for the purpose of being healthy.
6. If I have the strong motivation to be healthy through healthy eating, I think I can be persistent in it.
7. I would persist in healthy eating for the purpose of being healthy.
8. If I planned to eat healthily for the purpose of being healthy and I actually started my plan, I won't stop it easily.

## APPENDIX II

### ADOLESCENT FOOD HABITS CHECKLIST

1. If I am having lunch away from home, I often choose a low-fat option.  
True False I never have lunch away from home
2. I usually avoid eating fried foods. True False
3. I usually eat a dessert or pudding if there is one available. True False
4. I make sure I eat at least one serving of fruit a day. True False
5. I try to keep my overall fat intake down. True False
6. If I am buying crisps, I often choose a low-fat brand. True False I never buy crisps
7. I avoid eating lots of sausages and burgers.  
True False I never eat sausages or burgers
8. I often buy pastries or cakes. True False
9. I try to keep my overall sugar intake down. True False
10. I make sure I eat at least one serving of vegetables or salad a day. True False
11. If I am having a dessert at home, I try to have something low in fat.  
True False I don't eat desserts
12. I rarely eat takeaway meals. True False
13. I try to ensure I eat plenty of fruit and vegetables. True False
14. I often eat sweet snacks between meals. True False
15. I usually eat at least one serving of vegetables (excluding potatoes) or salad with my evening meal. True False
16. When I am buying a soft drink, I usually choose a diet drink.  
True False I never buy soft drinks
17. When I put butter or margarine on bread, I usually spread it thinly.  
True False I never have butter or margarine on bread
18. If I have a packed lunch, I usually include some chocolate and or biscuits.  
True False I never have a packed lunch
19. When I have a snack between meals, I often choose fruit.  
True False I never eat snacks between meals
20. If I am having a dessert or pudding in a restaurant, I usually choose the healthiest one.  
True False I never have desserts in restaurants
21. I often have cream on desserts.  
True False I don't eat desserts
22. I eat at least three servings of fruit most days.  
True False
23. I generally try to have a healthy diet.  
True False

APPENDIX III

THE TWO OTHER MOTIVATION SCALES

Personal Striving List

One way to describe oneself is to consider the purposes or goals that we are seeking in our everyday behavior. We are interested in the things that you typically or characteristically try to do. We might call these objectives "strivings." No matter what one's age or stage in life, there are certain goals or purposes that motivate us. Here are some examples of strivings:

- I typically try to go to church on Sundays because I believe in god.
- I typically try to get good grades because I want to please my parents.
- I typically try to help others in need of help because I want them good.
- I typically try to seek new and exciting experiences because I don't want to be bored.
- I typically try to avoid feeling inferior to others because I should not feel inferior to others.
- I typically try to eat a healthy, nutritious diet because I want to be healthy.

Note that these strivings are phrased in terms of what you are "trying" to do, regardless of whether or not you are actually successful. They may be fairly broad, such as "trying to make others happy," or more specific: "trying to make my partner happy." Also note that the strivings may be about something you typically try to obtain or keep, or things that you typically try to avoid or prevent. Finally, please note each striving has a reason for it.

You can see that this way of describing yourself is different from using trait adjectives (friendly, intelligent, honest). We do not want you to use trait adjectives. Since you may have never thought of yourself in this way before, think carefully about what we are asking you to do before you write anything down.

Now we want you to provide us with a list of your strivings. Please write down 12 strivings in the spaces provided. Please think of yourself and your purposes alone. Be as honest and as objective as possible; you shouldn't simply give socially desirable strivings or strivings you think you "ought" to have. Take your time with this task; spend some time thinking about your goals before you begin. (Please write clearly enough for us to read what you have written.)

I typically try to \_\_\_\_\_

because \_\_\_\_\_.

I typically try to \_\_\_\_\_

because \_\_\_\_\_.

I typically try to \_\_\_\_\_

because \_\_\_\_\_.

I typically try to \_\_\_\_\_

because \_\_\_\_\_.

I typically try to \_\_\_\_\_

because \_\_\_\_\_.

I typically try to \_\_\_\_\_

because \_\_\_\_\_.

I typically try to \_\_\_\_\_

because \_\_\_\_\_.

I typically try to \_\_\_\_\_

because \_\_\_\_\_.

I typically try to \_\_\_\_\_

because \_\_\_\_\_.

I typically try to \_\_\_\_\_

because \_\_\_\_\_.

I typically try to \_\_\_\_\_

because \_\_\_\_\_.

I typically try to \_\_\_\_\_

because \_\_\_\_\_.

## Motivation Ranking Scale

Please rank the following motives based upon their importance to you. Please be sure to read all the definitions before you rank them. Please put a number in front of each motive; “1” indicates the most important motive to you, “2” is less important compared to “1”, “3” is less important than “2”, and so on and so forth. There are no correct or right answers for this study. Your responses are anonymous and just for research purposes. Please be objective and honest.

Motives	Definitions
Achievement	characterized by a strong desire to meet standards of excellence; to anticipate achieving one’s goals; to be competitive in performance; and to persist in the face of obstacles
Power	characterized by a need to influence, persuade, and/or protect others; to be an organizer and an implementer; to practice dominance and leadership through strong, forceful actions; and to offer help
Affiliation	characterized by the desire to form friendships and associations; to maintain interpersonal networks; to desire to be liked and accepted; and to cooperate and work well with others
Intimacy	characterized by loving and tender behavior; the sharing of intimate thoughts and ideas in a trusting context, seeking harmony with others and desiring reciprocal help; and frequent dialogue or discussions of personal and/or relationship issues
Acquisition	characterized by wanting to gain possessions and property; bargaining for things and entering contests; working specifically for money or goods; and protecting and maintaining belongings
Health	characterized by a strong desire to exercise; to eat well; to live in a healthy environment; to stay in shape, and to be calm and tranquil while sleeping well and avoiding stress
Independence	characterized by striving for independence; resisting coercion and others' influence; seeking freedom; and being concerned with individuality and resisting conformity and authority

---

Organization	characterized by an emphasis on living in an orderly and structured fashion, according to schedule, being on time, being neat, and preferring regularity in one's life
Self-improvement	characterized by seeking to flourish and to find fulfillment however the individual defines it, especially through developing the self and being true to the self; by the desire of self-control and self-regulation
Honesty/Integrity	characterized by the desire to behave and live according to moral guidelines, to exhibit integrity and truthfulness; desiring to act with a sense of responsibility toward one's self and others
Instrumentality	characterized by the need to use time efficiently, to avoid laziness and staleness, and to keep one's self busy doing things, to perform needed or otherwise important acts in one's own and others lives
Novelty	characterized by needing to experience new things, especially thrilling and sensational experiences; wanting to do new and different activities in one's leisure time and to "blow off steam" by satisfying sudden urges
Religion /Spirituality	characterized by a need to understand one's higher purpose and place in the universe; desiring a strong sense of faith and loyalty to a higher power or God or gods; or seeking a deeper sense of spirituality
Enjoyment	characterized by the need of having fun, enjoying life, playing, and appreciating or being humorous
Social Goodness	characterized by a need to be a good person in the society, to do good things for others or community, to be unselfish and altruistic, to put others' needs before ones' own
Sex	characterized by a desire of having sexual relations with another person

---

## APPENDIX IV

### ROKEACH'S HEALTH VALUE SURVEY (Rokeach, 1973)

Please rank the following things based upon their importance to you. Please be sure to read all of them before you rank them. Please put a number in front of each motive; "1" indicates the most important motive to you, "2" is less important compared to "1", "3" is less important than "2", and so on and so forth. There are no correct or right answers for this study. Your responses are anonymous and just for research purposes. Please be objective and honest.

A comfortable life (a prosperous life)	Inner harmony (freedom from inner conflict)
An exciting life (a stimulating, active life)	Mature love (sexual and spiritual intimacy)
A sense of accomplishment (lasting contribution)	National security (protection from attack)
A world at peace (free of war and conflict)	Pleasure (an enjoyable, leisurely life)
A world of beauty (beauty of nature and the arts)	Salvation (saved, eternal life)
Equality (brotherhood, equal opportunity for all)	Self-respect (self-esteem)
Family security (taking care of loved ones)	Social recognition (respect, admiration)
Freedom (Independence, free choice)	True friendship (close companionship)
Health (physical and mental well-being)	Wisdom (a mature understanding of life)



## APPENDIX V

### HEALTH SELF-EFFICACY SCALE (Becker, et al., 1993)

The following are some health practices. Please make judgments about how well you are able to perform them. Then, please rate your ability of performing them on a 5-point scale, ranging from 0-not at all to 4-completely. There are no right or wrong answers. Your responses are anonymous and just for research purposes.

Please be objective and honest.

#### Exercise

- 1 Do exercises that are good for me
- 2 Fit exercise into my regular routine
- 3 Find ways to exercise that I enjoy
- 4 Find accessible places for me to exercise in the community
- 5 Know when to quit exercising
- 6 Do stretching exercise
- 7 Keep from getting hurt when I exercise

#### Nutrition

- 1 Find Healthy foods that are within my budget
- 2 Eat a balanced diet
- 3 Figure out how much I should weigh to be healthy
- 4 Tell which foods are high in fiber content
- 5 Figure out from labels that foods are good for me
- 6 Drink as much water as I need to drink every day

## APPENDIX VI

### IRB APPROVALS



### Social/Behavioral IRB – Expedited Review Approval Notice

**NOTICE TO ALL RESEARCHERS:**

*Please be aware that a protocol violation (e.g., failure to submit a modification for any change) of an IRB approved protocol may result in mandatory remedial education, additional audits, re-consenting subjects, researcher probation suspension of any research protocol at issue, suspension of additional existing research protocols, invalidation of all research conducted under the research protocol at issue, and further appropriate consequences as determined by the IRB and the Institutional Officer.*

**DATE:** February 3, 2009  
**TO:** Dr. Murray Millar, Psychology  
**FROM:** Office for the Protection of Research Subjects  
**RE:** Notification of IRB Action by Dr. Paul Jones, Co-Chair  
Protocol Title: **Self-Judgement on Daily Activities**  
Protocol #: 0812-2969

---

This memorandum is notification that the project referenced above has been reviewed by the UNLV Social/Behavioral Institutional Review Board (IRB) as indicated in Federal regulatory statutes 45 CFR 46. The protocol has been reviewed and approved.

The protocol is approved for a period of one year from the date of IRB approval. The expiration date of this protocol is January 28, 2010. Work on the project may begin as soon as you receive written notification from the Office for the Protection of Research Subjects (OPRS).

**PLEASE NOTE:**

Attached to this approval notice is the **official Informed Consent/Assent (IC/IA) Form** for this study. The IC/IA contains an official approval stamp. Only copies of this official IC/IA form may be used when obtaining consent. Please keep the original for your records.

Should there be *any* change to the protocol, it will be necessary to submit a **Modification Form** through OPRS. No changes may be made to the existing protocol until modifications have been approved by the IRB.

Office for the Protection of Research Subjects  
4505 Maryland Parkway • Box 451047 • Las Vegas, Nevada 89154-1047  
(702) 895-2794 • FAX: (702) 895-0805

Should the use of human subjects described in this protocol continue beyond January 28, 2010, it would be necessary to submit a **Continuing Review Request Form** *60 days* before the expiration date.

If you have questions or require any assistance, please contact the Office for the Protection of Research Subjects at [OPRSHumanSubjects@unlv.edu](mailto:OPRSHumanSubjects@unlv.edu) or call 895-2794.

COPY

Office for the Protection of Research Subjects  
4505 Maryland Parkway • Box 451047 • Las Vegas, Nevada 89154-1047  
(702) 895-2794 • FAX: (702) 895-0805



## Social/Behavioral IRB – Expedited Review Approval Notice

**NOTICE TO ALL RESEARCHERS:**

*Please be aware that a protocol violation (e.g., failure to submit a modification for any change) of an IRB approved protocol may result in mandatory remedial education, additional audits, re-consenting subjects, researcher probation suspension of any research protocol at issue, suspension of additional existing research protocols, invalidation of all research conducted under the research protocol at issue, and further appropriate consequences as determined by the IRB and the Institutional Officer.*

**DATE:** February 27, 2009  
**TO:** Dr. Murray Millar, Psychology  
**FROM:** Office for the Protection of Research Subjects  
**RE:** Notification of IRB Action by Dr. Paul Jones, Co-Chair  
Protocol Title: **Determinants of Daily Activities**  
Protocol #: 0901-2994

This memorandum is notification that the project referenced above has been reviewed by the UNLV Social/Behavioral Institutional Review Board (IRB) as indicated in Federal regulatory statutes 45 CFR 46. The protocol has been reviewed and approved.

The protocol is approved for a period of one year from the date of IRB approval. The expiration date of this protocol is February 4, 2010. Work on the project may begin as soon as you receive written notification from the Office for the Protection of Research Subjects (OPRS).

**PLEASE NOTE:**

Attached to this approval notice is the **official Informed Consent/Assent (IC/IA) Form** for this study. The IC/IA contains an official approval stamp. Only copies of this official IC/IA form may be used when obtaining consent. Please keep the original for your records.

Should there be *any* change to the protocol, it will be necessary to submit a **Modification Form** through OPRS. No changes may be made to the existing protocol until modifications have been approved by the IRB.

Office for the Protection of Research Subjects  
4505 Maryland Parkway • Box 451047 • Las Vegas, Nevada 89154-1047  
(702) 895-2794 • FAX: (702) 895-0805

Should the use of human subjects described in this protocol continue beyond February 4, 2010, it would be necessary to submit a **Continuing Review Request Form** *60 days* before the expiration date.

If you have questions or require any assistance, please contact the Office for the Protection of Research Subjects at [OPRSHumanSubjects@unlv.edu](mailto:OPRSHumanSubjects@unlv.edu) or call 895-2794.

COPY

Office for the Protection of Research Subjects  
4505 Maryland Parkway • Box 451047 • Las Vegas, Nevada 89154-1047  
(702) 895-2794 • FAX: (702) 895-0805

## BIBLIOGRAPHY

- Ajzen, I. (1985). From intentions to action: A theory of planned behavior. In J. Kuhl and J. Beckman (Eds.), *Action control: From cognitions to behaviors* (pp. 11-39). New York: Springer.
- Ajzen, I. (1988). *Attitudes, personality and behavior*. Milton Keynes: Open University Press.
- Ajzen, I. (1991). The theory of planned behavior. *Organizational Behavior and Human Decision Processes*, 50, 179-211.
- Ajzen, I., & Fishbein, M. (1980). *Understanding attitudes and predicting social behavior*. Englewood Cliffs, NJ: Prentice-Hall.
- Alexy, B. (1985). Goal setting and health risk reduction. *Nursing Research*, 34, 283-288.
- Armitage, C. J., & Conner, M. (2000). Social cognition models and health behavior: A structured review. *Psychology and Health*, 2000, 15, 173-189.
- Armitage, C. J., & Conner, M. (2001). Efficacy of the theory of planned behavior: A meta-analytic review. *British Journal of Social Psychology*, 40, 471-499.
- Armstrong, T., & Bull, F. (2006). Development of the World Health Organization global physical activity questionnaire (GPAQ). *Journal of Public Health*, 14, 66-70.
- Becker, M. H., Haefner, D. P., & Maiman, L. A. (1977). The health belief model in the prediction of dietary compliance: A field experiment. *Journal of Health and Social Behavior*, 18, 348-366.
- Becker, M. H. (1990). Theoretical models of adherence and strategies for improving adherence. In: SA Shumaker, E. B. Schron, J. K. Ockene, C. T. Parker, J. L. Probstfield, & J. M. Wolle (Eds.), *The handbook of health behavior change* (5-43).

- New York: Springer Publishing Company.
- Becker, H., Stuijbergen, A., Oh, H. S., & Hall, S. (1993). Self-rated abilities for health practices: A health self-efficacy measure. *Health Values: The Journal of Health Behavior, Education & Promotion, 17*, 42-50.
- Belloc, N. B. (1973). Relationship of health practices to mortality. *Preventive Medicine, 2*, 67-81.
- Blair, S. N. (1984). How to assess exercise habits and physical fitness. In: J. Matarazze, S. Weiss, J. Herd, & N. Miller (Eds.), *Behavioral health: A handbook of health enhancement and disease prevention* (pp. 424-447). New York: Wiley.
- Blue, C. L. (1995). The predictive capacity of the theory of reasoned action and the theory of planned behavior in exercise research: An integrated literature review. *Research in Nursing & Health, 18*, 105-121.
- Boer, H., & Seydel, E. R. (1996). Protection motivation theory. In: M. Conner and P. Norman (Eds.), *Predicting health behavior* (pp. 95-120). Buckingham, UK: Open University Press.
- Bollen, K. A. (1989). *Structural equations with latent variables*. New York: Wiley.
- Brenes, G. A., Strube, M. J., & Storandt, M. (1998). An application of the theory of planned behavior to exercise among older adults. *Journal of Applied Social Psychology, 28*, 2274-2290.
- Breslow, L., & Enstrom, J. E. (1980). Persistence of health habits and their relationship to mortality. *Preventive Medicine, 9*, 469-483.

- Browne, M. W., & Cudeck, R. (1993). Alternative ways of assessing model fit. In K. A. Bollen & J. S. Long (Eds), *Testing structural equation models* (pp. 136-162). Newbury Park, CA: Sage.
- Buckworth, J., Lee, R. E., Regan, G., Schneider, L. K., DiClemente, C. C. (2007). Decomposing intrinsic and extrinsic motivation for exercise: Application to stages of motivational readiness. *Psychology of Sport and Exercise*, 8, 441-461.
- Campbell, K. J., Crawford, D. A., & Hesketh, K. D. (2007). Australian parents' views on their 5-6-year-old children's food choices. *Health Promotion International*, 22, 11-18.
- Cantor, N. (1990). From thought to behavior: "Having" and "doing" in the study of personality and cognition. *American Psychologist*, 45, 735-750.
- Conner, M., & Norman, P. (1996). The role of social cognition in health behaviours. In M. Conner & P. Norman (Eds.), *Predicting health behavior: Research and practice with social cognition models* (pp.1-22). Buckingham, England: Open University Press.
- Conner, M., & Armitage, C. J. (1998). Extending the theory of planned behavior: a review and avenues for further research. *Journal of Applied Social Psychology*, 28, 1429-1464.
- Conner, M., & Norman, P. (1996). *Predicting health behavior: Research and practice with social cognition models*. Buckingham, England: Open University Press.
- Conner, M., & Sparks, P. (1996). The Theory of planned behavior and health behaviors. In M. Conner & P. Norman (Eds.), *Predicting health behavior: Research and practice with social cognition models* (pp.121-162). Buckingham, England: Open University Press.



- Cota, A.A., Longman, R.S., Holden R.R., & Rekken, G.C. (1993). Comparing different methods for implementing parallel analysis: A practical index of accuracy. *Educational and Psychological Measurement, 53*, 865-875.
- Cox C. (1982). An interaction model of client health behavior: Theoretical prescription for nursing. *Advances in Nursing Science, 5*, 41-56.
- Cox C. (1985). The health self-determinism index. *Nursing Research, 34*, 177-183.
- Cox C. (1986). The interaction model of client health behavior: Application to the study of community-based elders. *Advances in Nursing Science, 9*, 40-57.
- Croyle, R. T. (1992). Appraisal of health threats: Cognition, motivation, and social comparison. *Cognitive Therapy and Research, 16*, 165-182.
- Deci, E. L. & Ryan, R. M. (1985). The general causality orientations scale: Self-determination in personality. *Journal of Research in Personality, 19*, 109-134.
- Dishman, R. K., & Ickes, W. (1981). Self-motivation and adherence to therapeutic exercise. *Journal of Behavioral Medicine, 4*, 421-438.
- Dishman, R. K., Ickes, W., & Morgan, W. P. (1980). Self-motivation and adherence to habitual physical activity. *Journal of Applied Social Psychology, 10*, 115-132.
- Duda, J. L., & Tappe, M. K. (1988). Predictors of personal investment in physical activity among middle-aged and older adults. *Perceptual and Motor Skills, 66*, 543-549.
- Dzewaltowski, D. A. (1989). Toward a model of exercise motivation. *Journal of Sport and Exercise Psychology, 32*, 11-28.
- Emmons, R. A. (1986). Personal strivings: An approach to personality and subjective well-being. *Journal of Personality and Social Psychology, 51*, 1058-1068.
- Emmons, R. A. (1989). The personal striving approach to personality. In L. A. Pervin

- (Ed.), *Goal concepts in personality and social psychology* (pp. 87-126). Hillsdale, NJ, England: Lawrence Erlbaum Associates, Inc.
- Emmons, R. A. (1999). *The Psychology of ultimate concerns*. New York: Guilford.
- Evers, W., & Carol, B. (2007). An internet-based assessment tool for food choices and physical activity behaviors. *Journal of Nutrition Education and Behavior*, *39*, 105-106.
- Fishbein, M, & Ajzen, I. (1975). *Belief, attitude, intention, and behavior*. New York: Wiley.
- Fisher, J. D., Fisher, W. A., Williams, S. S., & Malloy, T. E. (1994). Empirical tests of an information-motivation-behavioral skills model of AIDS-preventive behavior with gay men and heterosexual university students. *Health Psychology*, *13*, 238-250.
- Floyd, D. L., Prentice-Dunn, S., & Rogers, R. W. (2000). A meta-analysis of research on protection motivation theory. *Journal of Applied Social Psychology*, *30*, 407-429.
- Freud, S. (1915/1963). Instincts and their vicissitudes. In P. Rieff (Ed.), *General psychological theory: Papers on metapsychology* (C. M. Baines, Trans.). New York: Macmillan Publishing.
- Godin, G., Desharnais, R., Jobin, J., & Cook, J. (1987). The impact of physical fitness and health-age appraisal upon exercise intentions and behavior. *Journal of Behavioral Medicine*, *10*, 241-250.
- Godin, G., & Kok, G. J. (1996). The theory of planned behavior: A review of its applications to health related behaviors. *American Journal of Health Promotion*, *11*, 87-98.
- Gollwitzer, P. M. (1987). The implementation of identity intentions: A motivational-

- volitional perspective on symbolic self-completion. In F. Halisch & J. Kuhl (Eds.), *Motivation, intention, and volition* (pp. 279-307). New York, NY, US: Springer-Verlag Publishing.
- Gollwitzer, P. M. (1990). Action phases and mind-sets. In E. T. Higgins and R. M. Sorrentino (Eds.), *Handbook of motivation and cognition: Foundations of social behavior* (Vol. 2, pp. 53-92). New York: Guilford.
- Gollwitzer, P. M. (1993). Goal Achievement: The role of intentions. In W. Stroebe and M. Hewstone (Eds.), *European review of social psychology* (Vol. 4, pp. 141-185). Chichester, UK: Wiley.
- Gollwitzer, P. M., & Oettingen, G. (1998). The emergence and implementation of health goals. *Psychology and Health, 13*, 687-715.
- Halisch, F., & Kuhl, J. (1987). *Motivation, intention, and volition*. New York, NY, US: Springer-Verlag Publishing.
- Hall, S. M. (1983). Smoking cessation in patients with cardiopulmonary disease: An initial study. *Addictive Behaviors, 8*, 33-42.
- Hamburg, D. A., Elliot, G. R., & Parron, D. L. (1982). *Health and behavior: Frontiers of research in biobehavioral sciences*. Washington, DC, US: National Academy Press.
- Hardeman, W., Johnston, M., Johnston, D. W., Bonetti, D., Wareham, N. J., & Kinmonth, A. L. (2002). Application of the theory of planned behavior in behavior change interventions: A systematic review. *Psychology & Health, 17*, 123-158.
- Harrison, J. A., Mullen, P. D., & Green, L. W. (1992). A meta-analysis of studies of the health belief model with adults. *Health Education Research, 7*, 107-116.
- Heckhausen, H., & Kuhl, J. (1985). From wishes to action: The dead ends and short cuts

- on the long way to action. In M. Frese & J. Sabini (Eds.), *Goal-directed behavior: psychological theory and research on action* (pp. 134-160). Hillsdale, NJ: Erlbaum.
- Heckhausen, H. (1991). *Motivation and action*. (P. K. Leppmann, Trans.). New York, NY, US: Springer-Verlag Publishing.
- Hill, D., Gardner, G., & Rassaby J. (1985). Factors predisposing women to take precautions against breast and cervix cancer. *Journal of Applied Social Psychology*, *15*, 59-79.
- Hodgkins, S., Sheeran, P., & Orbell, S. (1998). *Prediction and intention in health-related behavior: A meta-analytic review of protection motivation theory*. Unpublished manuscript, University of Sheffield, UK.
- Horn, J.L. (1965). A rationale and test for the number of factors in factor analysis. *Psychometrika*, *30*, 179-185.
- Hu, L. T. & Bentler, P. M. (1999). Cutoff criteria for fit indices in covariance structure analysis: Conventional criteria versus new alternatives. *Structural Equation Modeling*, *6*, 1-55.
- Jackson, D. N. (1999). *Personality Research Form manual* (3<sup>rd</sup> ed.). Port Huron, MI: Sigma Assessment Systems, Inc.
- Janz, N. K., & Becker, M. H. (1984). The health belief model: A decade later. *Health Education Quarterly*, *11*, 1-47.
- Johnson, F., Wardle, J., & Griffith, J. (2002). The Adolescent Food Habits Checklist: Reliability and validity of a measure of healthy eating behavior in adolescents. *European Journal of Clinical Nutrition*, *56*, 644-649.
- Kalichman, S. C., Picciano, J. F., & Roffman, R. A. (2008). Motivation to reduce HIV

- risk behaviors in the context of the information, motivation and behavioral skills (IMB) model of HIV prevention. *Journal of Health Psychology*, 13, 680-689.
- Kaplan, G. D., & Cowles, A. (1978). Health locus of control and health value in the prediction of smoking reduction. *Health Education monographs*, 6, 129-137.
- Kelly, G. A. (1962). Europe's matrix of decision. *Nebraska Symposium on Motivation* (Vol. 10). Lincoln, NE: University of Nebraska Press.
- Kelly, R. B., Zyzanski, S. J., & Alemagno, S. A. (1991). Prediction of motivation and behavior change following health promotion: Role of health beliefs, social support, and self-efficacy. *Social Science & Medicine*, 32, 311-320.
- King, L. A. (1995). Wishes, motives, goals, and personal memories: Relations of measures of human motivation. *Journal of Personality*, 63, 985-1007.
- Kline R. B. (2005). Principles and practice of structural equation modeling (2<sup>nd</sup> ed.). New York, NY, US: Guilford Press.
- Klinger, E. (1975). Consequences of commitment to and disengagement from incentives. *Psychological Review*, 82, 223-231.
- Koop, C. E. (1983). Perspectives on future health care. *Health Psychology*, 2, 303-312.
- Kuhl, J. (1987). Action control: The maintenance of motivational states. In F. Halisch & J. Kuhl (Eds.), *Motivation, intention, and volition* (pp. 279-307). New York, NY, US: Springer-Verlag Publishing.
- Lau R. R., Hartman, K. A., & Ware, J. E. (1986). Health as a value: Methodological and theoretical considerations. *Health Psychology*, 5, 25-43.
- Lewin, K. (1935). *A dynamic theory of personality*. New York: McGraw-Hill.
- Liebman, M., Pelican, S., Moore, S. A., Holmes, B., Wardlaw, M. K., Melcher, L. M., et

- al., (2003). Dietary intake, eating behaviors, and physical activity-related determinants of high body mass index in rural communities in Wyoming, Montana, and Idaho. *International Journal of Obesity*, 27, 684-692.
- Little, B. R. (1983). Personal projects: A rational and method for investigation. *Environment and Behavior*, 15, 273-309.
- Little, B. R. (1999). Personality and motivation: Personal action and the conative evolution. In Pervin, L. A. & John, O. P. (eds.), *Handbook of personality* (pp. 501-524). New York: The Guilford Press.
- Lowry, R., Galuska, D. A., Fulton, J. E., Wechsler, H., Kann, L., & Collins, J. L. (2000). Physical activity, food choice, and weight management goals and practices among U.S. college students. *American Journal of Preventive Medicine*, 18, 18-27.
- Maddux, J. E. (1993). Social cognitive models of health and exercise behavior: An introduction and review of conceptual issues. *Journal of Applied Sport Psychology*, 5, 116-140.
- Maslow, A. H. (1970). *Motivation and personality* (2<sup>nd</sup> ed.). New York, NY, US: Harper & Row Publishers.
- McAuley, E., Wraith, S., & Duncan, T. E. (1991). Self-efficacy, perceptions of success, and intrinsic motivation for exercise. *Journal of Applied Social Psychology*, 21, 139-155.
- McClelland, D. C. (1951). *Personality*. New York: Sloane.
- McClelland, D. C. (1985). *Human motivation*. US: Scott, Foresman and Company.
- McEwen, M. (1993). The health motivation assessment inventory. *Western Journal of Nursing Research*, 15, 770-779.

- Moorman, C. (1990). The effects of stimulus and consumer characteristics on the utilization of nutrition information. *Journal of Consumer Research*, 17, 362-374.
- Murray, E. J. (1964). *Motivation and emotion*. Englewood Cliffs, New Jersey: Prentice Hall Inc.
- Murray, H. A. (1938). *Explorations in personality*. New York: Oxford University Press.
- Murray, H. A. (1943). *Thematic Apperception Test manual*. Cambridge, MA: Harvard University Press.
- Norman, P., & Bennett, P. (1996). Health locus of control. In M. Conner & P. Norman (Eds.), *Predicting health behavior: Research and practice with social cognition models* (pp. 62-94). Buckingham, England: Open University Press.
- Norman P., & Conner, M. (1996). The role of social cognition models in predicting health behaviors: Future directions. In M. Conner & P. Norman (Eds.), *Predicting health behavior: Research and practice with social cognition models* (pp. 197-225). Buckingham, England: Open University Press.
- Nuttin, J. R. (1987). The respective roles of cognition and motivation in behavioral dynamics, intention, and volition. In F. Halisch & J. Kuhl (Eds.), *Motivation, Intention, and Volition* (pp. 309-320). New York, NY, US: Springer-Verlag Publishing.
- Papacharisis, V., & Goudas, M. (2003). Perceptions about exercise and intrinsic motivation of students attending a health-related physical education program. *Perceptual and Motor Skills*, 97, 689-696.
- Riccio-Howe, L. A. (1991). Health values, locus of control, and cues to action as predictors of adolescent safety belt use. *Journal of Adolescent Health*, 12, 256-262.

- Richetin, J., Perugini, M., Prestwich, A., O’Gorman, R. (2007). The IAT as a predictor of food choice: The case of fruits versus snacks. *International Journal of Psychology*, 42, 166-173.
- Rippetoe, P., & Rogers, R. (1987). Effects of components of protection motivation theory on adaptive and maladaptive coping with a health threat. *Journal of Personality and Social Psychology*, 52, 596-604.
- Rogers, R. (1983). Cognitive and physiological processes in fear-based attitude change: A revised theory of protection motivation. In J. Cacioppo & R. Petty (Eds.), *Social psychophysiology: A sourcebook* (pp. 153-176). New York: Guilford Press.
- Rogers R. W., & Prentice-Dunn S. (1997). Protection motivation theory. In D. S. Gochman (Ed.), *Handbook of health behavior research I: Personal and social determinants* (pp. 113-132). New York: Plenum Press.
- Rokeach, M. (1973). *The Nature of human values*. New York: Free Press.
- Rosenstock, I. M. (1974). Historical origins of the health belief model, *Health Education Monographs*, 2, 1-8.
- Schwarzer, R. (1992). Self-efficacy in the adoption and maintenance of health behaviors: Theoretical approaches and a new model. In: R. Schwarzer (Ed.), *Self-efficacy: thought control of action* (pp. 217-243). London: Hemisphere.
- Schwarzer, R., & Fuchs, R. (1996). Self-efficacy and health behaviors. In M. Conner & P. Norman (Eds.), *Predicting health behavior: Research and practice with social cognition models* (pp. 163-196). Buckingham, England: Open University Press.
- Seydel, E., Taal, E., & Wiegman, O. (1990). Risk-appraisal, outcome and self-efficacy expectancies: cognitive factors in preventive behavior related to cancer. *Psychology*



- and Health, 4, 99-109.*
- Sheeran, P., & Abraham, C. (1996). The health belief model. In M. Conner & P. Norman (Eds.), *Predicting health behavior: Research and practice with social cognition models* (pp.23-61). Buckingham, England: Open University Press.
- Sheeran, P., & Orbell, S. (1998). Do intentions predict condom use? Meta-analysis and examination of six moderator variables. *British Journal of Social Psychology, 37, 231-250.*
- Sheeran, P., & Taylor, S. (1999). Predicting intentions to use condoms: A meta-analysis and comparison of the theories of reasoned action and planned behavior. *Journal of Applied Social Psychology, 29, 1624-1675.*
- Sherman, D. K., Mann, T., & Updegraff, J. A. (2006). Approach/avoidance motivation, message framing, and health behavior: Understanding the congruency effect. *Motivation and Emotion, 30, 165-169.*
- Song, R., June, K. J., & Kim, C. G. (2004). Comparisons of motivation, health behaviors, and functional status among elders in residential homes in Korea. *Public Health Nursing, 21, 361-371.*
- Stanley, M. A., & Maddux, J. E. (1986). Cognitive processes in health enhancement: Investigation of a combined protection motivation and self-efficacy model. *Basic and Applied Social Psychology, 7, 101-113.*
- Stephens, A., Pollard, T. M., & Wardle, J. (1995). Development of a measure of motives underlying the selection of food: The food choice questionnaire. *Appetite, 25, 267-284.*
- Stephens, A., & Wardle, J. (1999). Motivational factors as mediators of socioeconomic

- variations in dietary intake patterns. *Psychology & Health, 14*, 391-402.
- Strecher, V. J., Champion, V. L., & Rosenstock, I. M. (1997). The health belief model and health behavior. In D. S. Gochman (Ed.), *Handbook of health behavior research I: Personal and social determinants* (pp. 71-91). New York: Plenum Press.
- U.S. Department of Health and Human Services. (1979). *Surgeon general's report: Promoting health preventing disease, 1990 objectives for the nation*. Washington, DC: Public Health Services, National Institutes of Health.
- U.S. Department of Health and Human Services. (1980). *Promoting health and preventing disease*. Washington, DC: Public Health Services, National Institutes of Health.
- Velicer, W.F. (1976). Determining the number of components from the matrix of partial correlations. *Psychometrika, 41*, 321-327.
- Vroom, V. H. (1964). *Work and motivation*. New York: Wiley.
- Wardle, J. (1993). Food choices and health evaluation. *Psychology & Health, 8*, 65-75.
- World Health Organization. (2000). *World health report*. Geneva: World Health Organization (p.164).
- Wurtele, S. K., Britcher, J. C., & Saslawsky, D. A. (1985). Relationships between locus of control, health value, and preventive health behaviors among women. *Journal of Research in Personality, 19*, 271-278.
- Xu, X. (2006). Global motives: A way to better understand how measures of motivation relate. Master Thesis, University of New Hampshire.
- Xu, X., Mellor, D., Xu, Y., & Duan, L. (2008). A proposed update of Murrayan needs. *Motivation and Emotion* (submitted manuscript).

## VITA

Graduate College  
University of Nevada, Las Vegas  
Xiaoyan Xu

### Local Address:

4765 Gym Road #212  
Las Vegas, NV, 89119

### Home Address:

Banyan Middle School  
Renshou, Sichuan, 612566, P. R. China

### Degrees:

M.A., 2004-2006, University of New Hampshire, Durham, NH, USA: Social/Personality,  
Department of Psychology

M.A., 2000-2003, Southwest China University, Chongqing, China: Personality Process,  
School of Psychology;

B.S., 1995-1999, Chongqing Normal University, Chongqing, China: Mathematics  
Education, Department of Mathematics & Computer Sciences

### Awards and Fellowships:

#### *Major Awards*

Graduate & Professional Student Association Grant Funding (\$500), University of  
Nevada, Las Vegas, 2009

Graduate Access Scholarship (\$750), University of Nevada, Las Vegas, 2008

Summa cum laude, Southwest-China University, 2003

Graduate Fellowship, Southwest-China University, 2001, 2002, & 2003

#### *Essay Awards*

A review of theories of emotional intelligence, Southwest-China University, 2003

A brief review on the Bar-On's model of emotional intelligence and Emotional Quotient  
Inventory, Southwest-China University, 2002

### Publications:

#### *Published Journal Articles*

Mayer, J. D., Fable, M. A., & **Xu, X.** (2007). Seventy-five years of motivation measures  
(1930-2005): A descriptive analysis. *Motivation and Emotion, 31*, 83-103.

Zhang, J., & **Xu X.** (2004). A study of the characteristics of the emotional intelligence of  
college students. *Psychological Science (China), 27*, 293-296.

- Yang, J., **Xu, X.** & Zhang, J. (2003). A survey of the emotional intelligence of middle school students. *Journal of Southwest China University*, 28, 146-150.
- Xu, X.**, & Zhang, J. (2002). A brief review on Bar-On's model of emotional intelligence and emotional quotient inventory. *Psychological Science (China)*, 25, 77-80.
- Xu, X.**, & Zhang, J. (2002). A review of theories of emotional intelligence. *Journal of Southwest China University*, 28, 77-82.

#### *Chapters*

- Xu, X.** (2002). The emotional development of the adolescent. In J. Zhang (Ed.), *Adolescent Psychology* (pp. 175-203). Chongqing: Chongqing Press.
- Xu, X.** (2002). The moral development of the adolescent. In J. Zhang (Ed.), *Adolescent Psychology* (pp. 286-318). Chongqing: Chongqing Press.

#### Conference Presentations and Invited Talks:

- Xu, X.**, Xu, Y., Mellor, D., & Duan, L. (August, 2009). A Cross National Study of Achievement, Power, and Affiliation Motives, *American Psychological Association 117 Annual Convention*.
- Xu, X.**, Mellor, D., Xu, Y., & Duan, L. (April, 2009). A Proposed Update of Murrayan Needs, *Western Psychological Association 89th Annual Convention*.
- Linares, V., Wright T. D., **Xu, X.**, Brehman B., & Barchard K. A. (April, 2009). Relationship between Emotional Expressivity and Emotion Management, *Western Psychological Association 89th Annual Convention*.
- Xu, X.**, Barchard, K. A., Mayer, J. M., & Brehman, B. (April, 2008). Evaluating the quality of a new thematic motivation coding system. *Western Psychological Association 88th Annual Convention*.
- Scott J. R., Thompson A. R., Wright T. D., **Xu X.**, & Barchard K. A. (April, 2008). Data entry methods: Is double entry the way to go? *Western Psychological Association 88th Annual Convention*.
- Xu, X.** (March, 2008). Does the CMCS-SA work as well as those comparator motivation coding systems? 2008 Graduate & Professional Student Research Forum, *University of Nevada, Las Vegas*.
- Xu, X.** (April, 2007). A new general thematic measure of motivation. *A Psychology Research Group at the University of Rochester*
- Xu, X.** & Zhang, J. (August, 2004). The development of the emotional intelligence scale of college students. *Abstract Book of the 28th International Congress of Psychology*, Beijing, China.
- Xu, X.** & Zhang, J. (November, 2001). A study on the characteristics of emotional intelligence of college students. *The Ninth Chinese Academic Conference of Psychology Selection of Abstracts*. Guangzhou, China.

Dissertation Title: Health motivation in health behavior: Its theory and application.

Dissertation Examination Committee:

Chairperson, Dr. Murray Millar, Ph. D.

Committee Member, Dr. David Copeland, Ph. D.

Committee Member, Dr. Clayton Silver, Ph. D.

Committee Member, Dr. Cortney Warren, Ph. D.

Graduate Faculty Representative, Dr. Rebecca Nathanson