

2011

Assessment of Progressive Collapse Requirements for Precast Concrete Buildings

Feng Shi
Lehigh University

Follow this and additional works at: <http://preserve.lehigh.edu/etd>

Recommended Citation

Shi, Feng, "Assessment of Progressive Collapse Requirements for Precast Concrete Buildings" (2011). *Theses and Dissertations*. Paper 1122.

This Thesis is brought to you for free and open access by Lehigh Preserve. It has been accepted for inclusion in Theses and Dissertations by an authorized administrator of Lehigh Preserve. For more information, please contact preserve@lehigh.edu.

Assessment of Progressive Collapse Requirements for Precast Concrete Buildings

By

Feng Shi

A Thesis
Presented to the Graduate and Research Committee
Of Lehigh University
In Candidacy for the Degree of
Master of Science
In Structural Engineering

Lehigh University

September, 2011

This thesis is accepted and approved in partial fulfillment of the requirements for the Master of Science.

July 14th, 2011

Dr. Clay Naito

Associate Professor of CEE Department
Lehigh University

Thesis Advisor

Dr. Sibel Pamukcu

Chairperson of CEE Department
Lehigh University

ACKNOWLEDGEMENTS

I would like to express my sincere appreciation to my supervisor, Dr. Clay Naito for his precious advice and support throughout my Master of Science studies. It has been a great pleasure to work with him and this report could not have been successful without his inspiration and encouragement.

I would like to thank Dr. Ben T. Yen for his valuable recommendations and suggestions while giving unlimited supports and meaningful directions to me.

Finally, I would like to appreciate my wife, Yue Han, for her sincere encouragement and dedicated love while studying abroad. Special thanks to my family for their constant support. From my heart, I thank my parents, Xingsheng Shi and Huifang Li, for their endless care, support, and love and dedicate this report to them.

TABLE OF CONTENTS

Certificate of Approval.....	ii
Acknowledgements	iii
Table of Contents	iv
List of Figures	viii
List of Tables.....	xiii
Abstract	1
1. Introduction and Background.....	3
1.1. Historical Progressive Collapse Events.....	3
1.1.1 Oklahoma City	3
1.2. Literature Review of Analysis Methods.....	5
1.2.1 PCA Study.....	5
1.3. Codified Methods and Criteria	7
1.3.1 ACI-318.....	7
1.3.2 ASCE7-10	7
1.3.3 GSA.....	8
1.3.4 UFC	9
2. Design Details in Modeling Building Structure	10
2.1. Background on System Studies (PCI Seismic Handbook Example).....	10
2.1.1 Special Moment Frames.....	12
2.2. Loads and Load Conditions for Seismic Resistant Design.....	13
2.2.1 Basic Loads Information	13
2.2.2 Seismic Effects Information	14
2.2.3 Load Conditions	16
2.3. Design Details of the Building Structure.....	17
2.3.1 Design Details of Exterior Framing.....	17

2.3.2 Design Details of Interior Framing.....	20
3. Threat Evaluation due to Bombing.....	26
3.1. Column Capacity.....	26
3.1.1 Column Moment Capacity	26
3.1.2 Column Shear Capacity.....	31
3.2. Failure Cases Introduction.....	32
3.2.1 Brisance Failure (Close-in Design)	32
3.2.2 Flexural Failure (Far Field Design).....	33
3.2.3 Direct Shear Failure (Far Field Design)	33
3.3. Failure Cases Analysis	34
3.3.1 Brisance Failure (BF)	34
3.3.2 Flexural Failure (FF)	38
3.3.3 Direct Shear Failure (DSF).....	44
3.4. Combined Effects of Brisance Failure, Flexural Failure and Direct Shear Failure.....	47
3.4.1 Brisance Failure.....	48
3.4.2 Flexural Failure	49
3.4.3 Direct Shear Failure.....	49
3.4.4 Combined Effects of Failure Cases	50
3.5. Generalized Safe-range for Brisance Failure, Flexural Failure and Direct Shear Failure.....	51
3.6. Realistic Failure Criteria.....	53
4. Progressive Collapse Design Criteria and Guidelines.....	54
4.1. ACI-318 Recommendation for Precast Concrete Structures	54
4.1.1 Design Method	55
4.2. ASCE 7 2010.....	56
4.3. UFC	56
4.3.1 Determination of Occupancy Category (OC) and Design Method	57

4.3.2 Design Methods.....	58
4.3.3 Use of Design Methods for Precast Structures.....	63
4.4. GSA.....	63
4.4.1 Exemption Process.....	64
4.4.2 Design Methods.....	64
4.5. Summary of Comparisons of Details in GSA and UFC.....	66
4.5.1 Comparison of Procedures in Alternate Path Method in UFC.....	67
4.5.2 Comparison of Procedures in UFC and GSA.....	68
4.5.3 Comparison of Alternate Path Method in UFC and GSA.....	68
5. Progressive Collapse Modeling of Precast Structure.....	70
5.1. Introduction of Three Model Cases.....	70
5.1.1 Column Removal.....	70
5.1.2 Exterior Section.....	72
5.1.3 Interior Section.....	74
5.2. Analysis Package.....	75
5.2.1 System Model.....	75
5.2.2 Case1: Original Model.....	76
5.2.3 Case2: Modified Model with Cantilever Beam.....	78
5.2.4 Case3: Modified Model with Fixed-fixed Beam.....	80
5.3. Analysis and Design Criteria.....	81
5.3.1 GSA Load Combination and Acceptance Criteria.....	81
5.3.2 UFC Load Combination and Acceptance Criteria.....	82
5.3.3 General Comparison and Summary of GSA and UFC.....	83
5.4. Results Study of Three Model Cases.....	84
5.4.1 Case 1: Original Model.....	84
5.4.2 Case 2: Modified Model with Cantilever Beams.....	94

5.4.3 Case 3: Modified Model with Fixed-fixed Beam.....	105
5.5. Comparison of Three Models.....	109
5.5.1 Comparison of Numbers of Stories about Elements Modification.....	109
5.5.2 Comparison of Deflections from Case 2 and Case 3.....	110
5.6. Limitations of Progressive Collapse Evaluation.....	126
6. Conclusions.....	127
7. Reference.....	130
8. Vita.....	132

LIST OF FIGURES

Figure 1-1: Blast and progressive collapse damage of Oklahoma City Bomb (Smilowitz)....	4
Figure 1-2: Schematic diagram of blast damage in north face elevation (Smilowitz).....	4
Figure 1-3: Schematic diagram of blast damage in north-south section (Smilowitz).....	5
Figure 2-1: Plan view of the building system (PCI, 2007)	11
Figure 2-2: Spandrel beam cross section	18
Figure 2-3: Exterior column section at let-in for beam bearings (PCI, 2007)	19
Figure 2-4: Exterior column section at base (PCI, 2007)	19
Figure 2-5: Spandrel-to-column assembly (PCI, 2007).....	20
Figure 2-6: Details in spandrel-to-column connection (PCI, 2007)	20
Figure 2-7: Interior section of special moment frame from SDC-C (PCI, 2007).....	21
Figure 2-8: Reinforcement details about overhung frames (PCI, 2007).....	22
Figure 2-9: Reinforcement details in inverted tee beam cross section at the first floor level (PCI, 2007).....	22
Figure 2-10: Reinforcement details in overhung part of overhung frame (PCI, 2007)	23
Figure 2-11: Connection between drop-in inverted tee beam and overhanging portion of inverted tee beam (PCI, 2007)	23
Figure 2-12: Elevation of outside overhung frames (PCI, 2007).....	24
Figure 2-13: Elevation of inside frame (PCI, 2007)	24
Figure 2-14: Reinforcements in column cross section of interior section	25
Figure 2-15: Reinforcement details for interior column-to-column connection (PCI, 2007).	25
Figure 3-1: Column cross-sections	27
Figure 3-2: Resistance function column cross section.....	30

Figure 3-3: Shear damaged condition	32
Figure 3-4: Blast load effects due to Brisance Failure at W=500lb.....	35
Figure 3-5: Blast load effects due to Brisance Failure at W=1000lb.....	35
Figure 3-6: Blats load effects due to Brisance Failure at W=2000lb.....	36
Figure 3-7: Blast load effects due to Brisance Failure at W=8000lb.....	36
Figure 3-8: Blast load effects due to Brisance Failure at W=10000lb.....	37
Figure 3-9: Comparison of blast load effects due to Brisance Failure	38
Figure 3-10: Blast load applied on the column.....	39
Figure 3-11: Blast load applied on the walls	40
Figure 3-12: Blast load effects due to Flexural Failure at W=3250lb	41
Figure 3-13: Blast load effects due to Flexural Failure at W=5000lb	42
Figure 3-14: Blast load effects due to Flexural Failure at W=7000lb	43
Figure 3-15: Comparison of blast load effects due to Flexural Failure	44
Figure 3-16: Blast load effects due to Direct Shear Failure at W=500lb.....	45
Figure 3-17: Blast load effects due to Direct Shear Failure at W=5000lb.....	46
Figure 3-18: Comparison of blast load effects due to Direct Shear Failure	47
Figure 3-19: Brisance failure condition at W=5000lb.....	48
Figure 3-20: Flexural failure condition at W=5000lb.....	49
Figure 3-21: Direct shear failure condition at W=5000lb.....	50
Figure 3-22: Combined effects of failure cases	51
Figure 3-23: Generalized safe-range due to BF, FF, and DSF	52
Figure 3-24: Simplified safe-range due to BF, FF, and DSF.....	52
Figure 4-1: Typical arrangement of tensile ties in large panel structures (ACI318-08, 2008)	55

Figure 4-2: Tie forces in a frame structure (UFC4-023-03, 2010)	59
Figure 4-3: Plan view of removed column location (UFC4-023-03, 2010)	60
Figure 4-4: Plan view of loads and load locations of linear and nonlinear static models(UFC4-023-03, 2010).....	61
Figure 4-5: Elevation view of loads and load locations of linear and nonlinear static models (UFC4-023-03, 2010)	61
Figure 4-6: Plan view of external removed column locations of framed structure in GSA (GSA, Progressive Collapse Analysis and Design Guidelines, 2003).....	65
Figure 5-1: 3-D extruded view of the model simulated in ETABS	71
Figure 5-2: Extruded plan view of the model simulated in ETABS.....	71
Figure 5-3: Removed column location in Elevation-5 view of the model simulated in ETABS	72
Figure 5-4: Spandrel Beam Cross Section	73
Figure 5-5: Interior Section Inverted Tee Beam Story1-3 simulated in ETABS.....	74
Figure 5-6: Interior section Inverted Tee Beam Story4-8 simulated in ETABS	75
Figure 5-7: Properties of double tee slab(PCI, 2010)	76
Figure 5-8: Elevation-D of model of Case 1 in ETABS.....	77
Figure 5-9: Local Elevation-D of Case 1	78
Figure 5-10: Elevation-D of model of Case 2 in ETABS.....	79
Figure 5-11: Local Elevation-D of Case 2.....	79
Figure 5-12: Elevation-D of model of Case 3.....	80
Figure 5-13: Local Elevation-D in Case 3	81
Figure 5-14: Detailed checking locations for each response in Case 1	85

Figure 5-15: Moment distribution in Case 1	85
Figure 5-16: Shear force distribution in Case 1	86
Figure 5-17: Detailed checking locations for each response in Case 2	95
Figure 5-18: Moment distribution in Case 2.....	95
Figure 5-19: Shear force distribution in Case 2.....	96
Figure 5-20: Detailed checking locations for each response in Case 3	106
Figure 5-21: Moment distribution in Case 3.....	106
Figure 5-22: Shear force distribution in Case 3.....	107
Figure 5-23: Spandrel-to-column connection (PCI, 2007).....	111
Figure 5-24: Moment distribution of Case 2 if all pinned connections form in ETABS.....	111
Figure 5-25: Moment distribution of Case 3 if all pinned connections form in ETABS.....	112
Figure 5-26: Modified spandrel beam cross-section in Case 2.....	113
Figure 5-27: Vertical concentrated load applied on the cantilever beam	114
Figure 5-28: Yield and ultimate curvature-distance relationship by concentrated load for cantilever beam.....	114
Figure 5-29: End load-deflection relationship of Case 2 by GSA requirements	115
Figure 5-30: Concentrated load-deflection relationship of Case 2 by GSA requirements ...	116
Figure 5-31: Distributed load applied on the cantilever beam.....	117
Figure 5-32: Yield and ultimate curvature-distance relationship by distributed load for cantilever beam.....	117
Figure 5-33: Distributed load-deflection relationship of Case 2 by GSA requirements	118
Figure 5-34: Modified spandrel beam cross-section in Case 3.....	119
Figure 5-35: Vertical concentrated load applied on the simply-supported beam in Case 3 .	120

Figure 5-36: Yield and ultimate curvature-distance relationship by concentrated load for simply-supported beam.....	120
Figure 5-37: End load-deflection relationship of Case 3 by GSA requirements	121
Figure 5-38: Concentrated load-deflection relationship of Case 3 by GSA requirements ...	121
Figure 5-39: Distributed load applied on the simply-supported beam in Case 3	122
Figure 5-40: Yield curvature-distance relationship by distributed load for simply-supported beam.....	123
Figure 5-41: Distributed load-deflection relationship of Case 3 by GSA requirements	123
Figure 5-42: Comparison of direct load-deflection relationship in Case 2 and Case 3	124
Figure 5-43: Summary of deflections in Case 2 and Case 3.....	125

LIST OF TABLES

Table 2-1: Dead load information.....	13
Table 2-2: Live load information.....	14
Table 2-3: Line load information.....	14
Table 2-4: Coefficients in exterior section and interior section.....	15
Table 2-5: Lateral loads due to weight for the design of SDC-B and SDC-C.....	16
Table 2-6: Seismic Load Combinations for the design of SDC-B and SDC-C.....	16
Table 3-1: Resistance-deflection relationship.....	30
Table 3-2: Columns failure condition due to Brisanse Failure.....	34
Table 3-3: Combined blast load effects due to Three Failures.....	47
Table 4-1: UFC occupancy and design requirements.....	57
Table 4-2: Comparison of procedures of progressive collapse analysis and design in GSA and UFC.....	68
Table 4-3: Comparison of Alternate Path method in UFC and GSA.....	69
Table 5-1: Moment and Shear Capacity Details in Connections (un-factored).....	75
Table 5-2: Comparison and Summary of GSA and UFC in load combination and acceptance criteria.....	83
Table 5-3: Response of Case 1 by GSA requirements.....	87
Table 5-4: Response of Case 1 by UFC requirements.....	90
Table 5-5: Summary of response of Case 1 by GSA and UFC requirements.....	93
Table 5-6: Summarized modification details of Case 1 by GSA and UFC requirements.....	94
Table 5-7: Response of Case 2 by GSA requirements.....	96
Table 5-8: Response of Case 2 by UFC requirements.....	100

Table 5-9: Summary of response of Case 2 by GSA and UFC requirements	104
Table 5-10: Summarized modification details of Case 2 by GSA and UFC requirements ..	105
Table 5-11: Summary of response of Case 3 by GSA and UFC requirements.....	108
Table 5-12: Summarized modification details of Case 3 by GSA and UFC requirements ..	109
Table 5-13: Comparison of design modifications using GSA and UFC requirements.....	110
Table 5-14: Summary of deflections in Case 2 and Case 3	125

ABSTRACT

Threat evaluations due to bombing and progressive collapse of precast concrete building systems are examined and presented in this report. A prototype structure based on the moment frame building system from PCI-Seismic Design for Precast/Prestressed Concrete Structures is used for these evaluations. Two distinct studies are conducted. The first examines the potential for abrupt failure of the ground level columns due to intentional detonation of explosives; the second examines the potential for progressive collapse of the building system as a result of this loss. Three types of column failures, including brisance failure, flexural failure, and direct shear failure are discussed and evaluated based on blast load effects. For each failure case, the number of failed columns respect to stand-off ranges with specified weight of charges is determined by employing UFC-3-340-02. A pictorial representation of the stand-off distances and number of failed columns are provided to assess the combined effects of blast load types with a specified charge weight. The generalized image provides a safe-range for each failure type. This methodology can be used to guide engineers in making enhancement to columns based or safe standoff ranges to ensure that safe operating levels are satisfied. In progressive collapse analysis section, the structure is examined using the procedures of the Unified Facilities Criteria (UFC) and the General Services Administration (GSA). Three model cases are compared: original model, modified model with cantilever continuous beam, and modified model with fixed-fixed continuous beam, analyze progressive collapse responses and make modifications by employing linear static procedure. The current GSA progressive collapse guidelines and UFC progressive collapse design are used for evaluations, and the commercially available structural analysis program ETABS Nonlinear V9.7.1 is utilized to perform example analyses. The evaluations

show that UFC provides more conservative requirements in progressive collapse resistance than GSA does. Additionally, the deflections directly above the removed column are evaluated in the modified models with adequate strength, since the original model shows insufficient progressive collapse resistance due to inadequate strength of steel plates and anchorage bars. Consequently, the fixed-fixed continuous beam model, which is modified as simply-supported beam, is preferable due to smaller deflection evaluated.

1. INTRODUCTION AND BACKGROUND

According to The United States General Service Agency (GSA)(GSA, Progressive Collapse Analysis and Design for New Federal Buildings and Major Modernization Projects, 2003), progressive collapse is defined as *“a situation where local failure of a primary structural component(s) lead to the collapse of adjoining members, which in turn leads to additional collapse. Hence, the extent of total damage is disproportionate to the original cause”*. Another way of describing progressive collapse is a chain reaction or propagation of failures following damage of a relatively small portion of a structure. The potential for progressive collapse as a result of an explosion induced failure is examined in this thesis. The study focuses on the potential for progressive collapse mechanisms in precast concrete structural systems.

1.1. Historical Progressive Collapse Events

To provide insight on progressive collapse and the potential implications for precast structures a brief review of major progressive collapse events are provided. Included in the review are the 1995 Alfred P. Murrah Building, and the Ronan Point failure.

1.1.1 Oklahoma City

The Oklahoma City Bombing of Alfred P. Murrah Federal Office Building occurred on April 19th, 1995. This office building was built in 1970s, 9-story reinforcement concrete frame and shear walls consisted its main part. The north side of the building facing the blast loads contained corner column and four other perimeter columns. A truck taken 4000 lb of ANFO was parked near the north side of the building and the distance to the nearest column from the truck is 15.6 ft. The blast wave propagated to the north side of the building, one column was disintegrated directly and two others damaged due to brittle failure. The failure of

transfer girder at the third level resulted in the upper-level collapsed in the progressive fashion. As a result, only 4% of columns were failed due to blast loads; however, 44% of columns were damaged based on progressive collapse. Therefore, progressive collapse is an important factor leading to severe failure of the structure. An image of the failed building is illustrated in Figure 1-1 through Figure 1-3 (ASCE7-10, 2010).

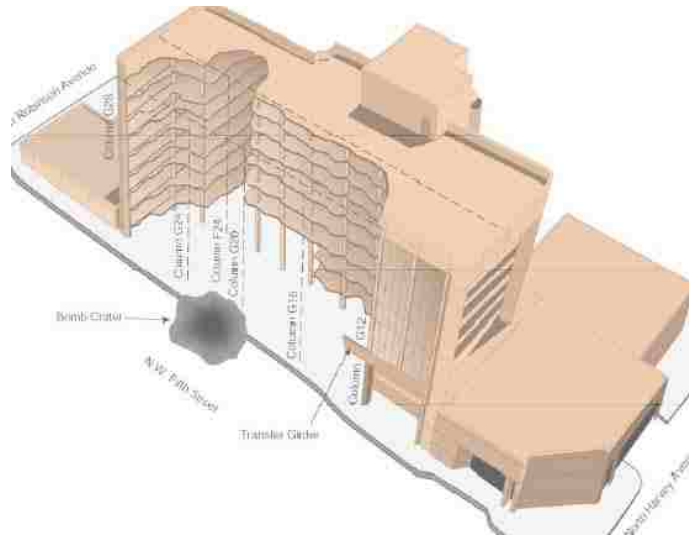

Figure 1-1: Blast and progressive collapse damage of Oklahoma City Bomb (Smilowitz)

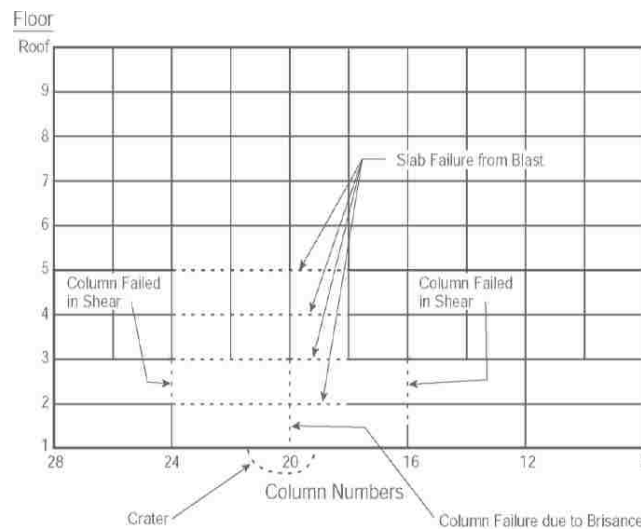

Figure 1-2: Schematic diagram of blast damage in north face elevation (Smilowitz)

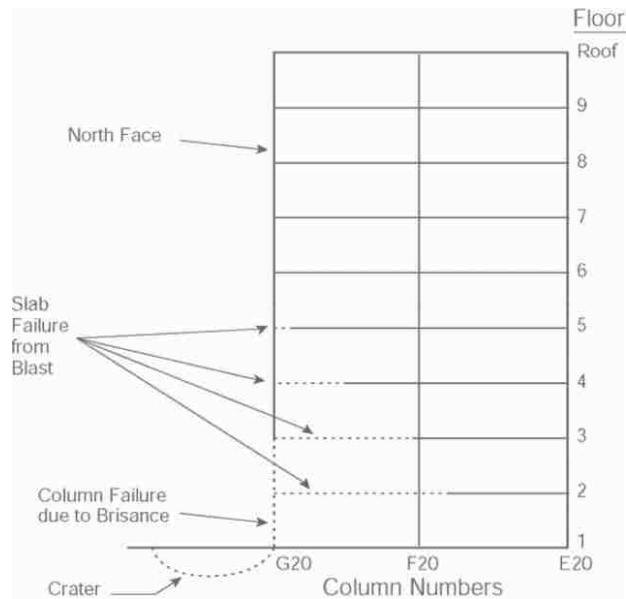

Figure 1-3: Schematic diagram of blast damage in north-south section (Smilowitz)

1.2. Literature Review of Analysis Methods

1.2.1 PCA Study

Structures which safely support conventional design loads may be subject to local damage from abnormal loads such as explosions due to accidental ignition of gas or industrial liquids. Generally, such abnormal loads or events are not design considerations, except for specially designed protective systems. For structures designed to resist such unforeseeable events, minor changes in reinforcement detailing can be made to provide continuity, redundancy and increase the ductility of the structure, and thus limit the effects of local damage to help prevent or minimize progressive collapse (PCA, 2006).

“The overall ability of a reinforced concrete structure to withstand such abnormal loads can be substantially enhanced by providing relatively minor changes in the detailing of the reinforcement, without impacting the overall economy. ACI-318 Section 7.13 provides a requirement of structural integrity for concrete buildings, intended to improve the redundancy and ductility of structures. This is achieved by providing, as minimum, some continuity reinforcement or tie between horizontal framing members. In the event of damage to a major supporting element or an abnormal loading, the integrity reinforcement is intended to confine any resulting damage to a relatively small area, thus improving overall stability”(PCA, 2006).

“Since accidents are normally unforeseeable events, they cannot be defined precisely; likewise, providing general structural integrity to a structure is a requirement that cannot be stated in simple terms. A level of judgment on the part of designer is required to effects and improvements of structural integrity, and differing opinions among designers about how to effectively provide a structural integrity solution for a particular framing system will be generated”(PCA, 2006).

ACI-318 includes specific requirements for reinforcement details for cast-in-place joists, beams, two-way slab construction, and precast structures. For this report, precast concrete structures are examined.

1.2.1.1 Precast Concrete Structure Construction

According to ACI318 (ACI318-08, 2008), precast concrete structural integrity is achieved through the use of TENSION TIES which consist of reinforcement and connection hardware. For precast concrete construction, tension ties are provided in the transverse, longitudinal, and vertical directions and around the perimeter of the structure to effectively tie elements together.

Longitudinal and Transverse ties connect members to a lateral load-resisting system (roof or floor system). Where precast elements form floor or roof diaphragms, the connections between diaphragms and those laterally supported members shall have a nominal tensile strength capable of resisting not less than 300lb/ft (ACI318-08, 2008).

Vertical tension tie requirements shall apply to all vertical structural members, except cladding, and shall be achieved by providing connections at horizontal joints. For precast columns, the nominal strength in tension shall not be less than $200A_g$ in lbf, where A_g is the area of the cross section of the column. If the area of cross section is larger than required by load consideration, a reduced area A_g , based on cross section required but not less than one-half the total area, shall be permitted. For precast wall panels, a minimum of two ties shall be used per panel, with a nominal tensile strength not less than 10000lb/tie. When no tension

acts at the base by design forces, the ties shall be permitted to be anchored into an appropriately reinforced concrete floor slab on ground (ACI318-08, 2008).

As previously mentioned, this report focuses on progressive collapse analysis of precast concrete structures. Instead of examining the use of tension ties through the floor and roof systems, two modified cases studies on spandrel beams are developed in order to determine the preferable solution against disproportional damage due to progressive collapse (ACI318-08, 2008).

1.3. Codified Methods and Criteria

Four progressive collapse design standards are examined in this section.

1.3.1 ACI-318

As described in 1.2.1.1, structural integrity in ACI318 (ACI318-08, 2008) provides requirements for the use of TENSION TIES in precast concrete structures. Tension ties shall be provided in the transverse, longitudinal, and vertical directions and around the perimeter of the structure to effectively tie elements together. The overall integrity of a structure can be substantially enhanced by minor changes in the amount, location, and detailing of member reinforcement and in the detailing of connection hardware, however, connection details that rely solely on friction caused by gravity forces are not permitted. For a detailed background a review of the base document ACI-318 is recommended. The document is listed as open distribution and is available.

1.3.2 ASCE7-10

ASCE (ASCE7-10, 2010) directs attention to the problem of local collapse, presents guidelines for handling it that will aid the design engineer, and promotes consistency of

treatment in all types of structures and in all construction materials. Generally, connections between structural components should be ductile and have a capacity for relatively large deformation and energy absorption under the effect of abnormal conditions. ASCE 7-10 provides a number of conceptual ways of designing for the required integrity, such as good plan layout, returns on wall, ductile detailing and so forth. For example, in bearing-wall structures there should be an arrangement of interior longitudinal walls to support and reduce the span of long sections of cross wall, thus enhancing the stability of individual walls and of the structures as a whole. In the case of local failure, this will also decrease the length of wall likely to be affected. In consideration of ductile detailing, avoid low-ductility detailing in elements that might be subject to dynamic loads or very large distortions during localized failures. For a detailed background a review of the base document ASCE7-10 is recommended. The document is listed as open distribution and is available.

1.3.3 GSA

The GSA guidelines are used for design of Federal Facilities, specifically for the design of new facilities, the assessment of existing facilities, and development of upgrades where needed. Exemption is allowed for facilities with extremely low occupancy and extremely low likelihood for progressive collapse (GSA, Progressive Collapse Analysis and Design for New Federal Buildings and Major Modernization Projects, 2003). An exemption evaluation process is provided. If the facility is not exempt from further consideration of progressive collapse, a linear analysis procedure and/or nonlinear procedure are used. The approach specifically removes one vertical element in the considered location and level in exterior or interior sections for each analysis. For a detailed background a review of the base document

GSA is recommended. Chapter 4 in this report provides more detailed information about GSA criteria.

1.3.4 UFC

The UFC (UFC-4-023-03, 2010) method is applied to both new and existing buildings for military and government facilities. The design approach is dependent on the use or occupancy of the building structure. Based on the level of occupancy three design approaches are used. They include the tie force (TF), enhanced local resistance (ELR), and alternate load path (AP) method. For high levels of occupancy and criticality all three methods may be required while for low levels of criticality none of the methods may be needed. For a detailed background a review of the base document UFC 4-023-03 is recommended. Chapter 4 in this report provides more detailed information about UFC criteria. Comparisons of UFC and GSA are also included in Chapter 4.

2. DESIGN DETAILS IN MODELING BUILDING STRUCTURE

A prototype building is chosen for this study. The prototype is based on the example provided in the PCI Seismic Design Handbook. This chapter provides a summary of the geometry of the building and the details used in the structure.

2.1. Background on System Studies (PCI Seismic Handbook Example)

The example building from PCI seismic design book (PCI, 2007) is a three-bay wide by seven-bay long structure with two lines of inverted tee beams and columns in the interior. The exterior framing uses columns and load bearing spandrel beams that also serve as the architectural exterior finish. The corners of the plan are inset and chamfered as part of the architecture layout to provide lateral support in the orthogonal direction but are not considered as contributing to vertical or lateral resistance in the longitudinal direction of the plan developed in this example. The roof level is framed in the same way with a partial mechanical penthouse roof cover with light steel framing. For simplicity, the load at this level is assumed to be comparable to the lower level floor loads.

The structure used in progressive collapse analysis is a combined frame due to Seismic Design Category B and C. The exterior framing is designed based on Seismic Design Category B, which belongs to ordinary moment frames. The interior framing is designed based on Seismic Design Category C, which belongs to special moment frames. This combined structure provides more conservative seismic resistance when seismic design category B (SDC-B) is required. Therefore, the building system is analyzed on SDC-B requirements. Figure 2-1 illustrates a plan view of the precast concrete structure from PCI (PCI, 2007).

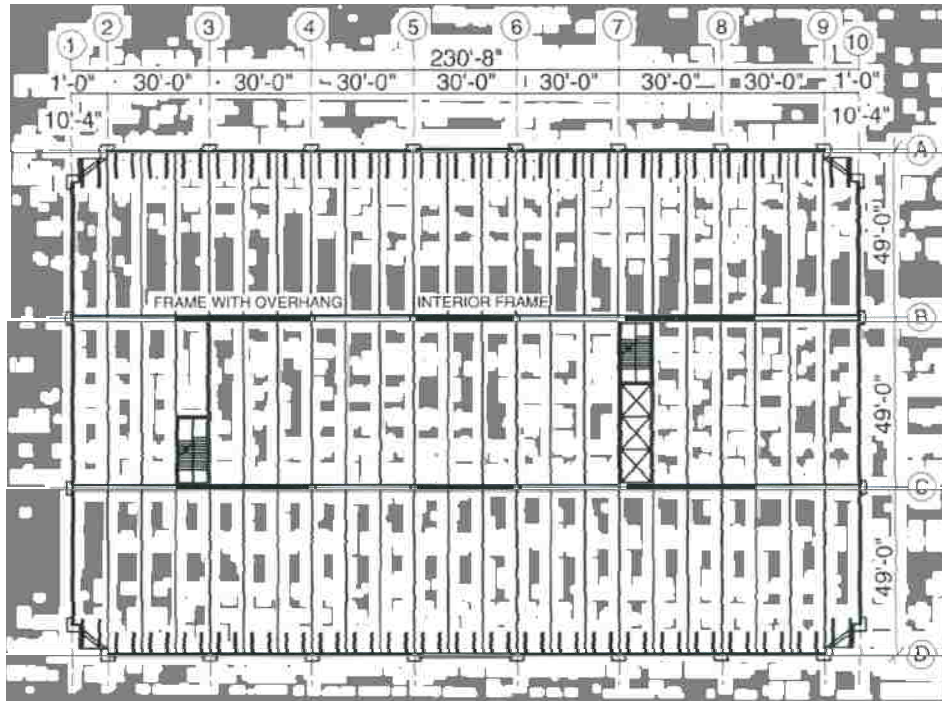

Figure 2-1: Plan view of the building system (PCI, 2007)

According to PCI seismic design book (PCI, 2007), concrete frame structures assigned to seismic design category B are permitted to use ordinary moment frames. These are defined as cast-in-place or precast frames meeting the requirements of ACI-318(ACI318-08, 2008), not including the special prescriptive requirements for seismic design. To reflect the likelihood of low ductility and unfavorable failure mechanisms, ordinary concrete moment frames are assigned a low response modification factor ($R = 3$).

When an engineer elects to use a frame and the seismic requirements permit an ordinary moment frame, it is usually more economical to develop frame continuity through connections made within the gravity load system. In this way, the components that are ordinarily required are extended to provide lateral support without additional components. Connecting these beams to induce negative moments at the columns is not desirable. Negative moments from beam continuity would be additive to the effects of prestressing with a potentially severe demand for top steel and concrete compressive strength. The connections

required for continuity would impose restraints on those elements with the highest creep and shrinkage movements. Poor performance of rigidly-connected prestressed concrete beams experienced early in the development of the precast/prestressed concrete building industry provided valuable lessons that are still valid today. Problems of this nature are rare today because these conditions are avoided. Where it is necessary to establish frame continuity in the precast gravity system, the deep precast spandrel beams on the building perimeter are a preferable option. These beams are naturally dimensioned deeper to provide for both support of the floor framing and for railing or wall height to the windows above the floor. With this depth, they may be lightly prestressed for flexural strength. It is common for these beams to include prestressing above the neutral axis for crack control, particularly for handling consideration. To establish frame continuity, connections can be made near the top and the bottom of the beams with a larger distance between tension/compression that tends to moderate the forces (PCI, 2007).

2.1.1 Special Moment Frames

For combination of seismic hazard, occupancy, and soils that produce moderate seismic risk, the intermediate seismic design category is C. The model codes do not permit ordinary moment frames to be used in category C structures. They require that concrete frames be at least intermediate moment frames. ACI-318-2002 defines an intermediate moment frame as a cast-in-place frame meeting limited detailing requirements. An engineer might develop a precast system that emulates the monolithic cast-in-place concrete intermediate frame and use the assigned R value of 5. The emulation requirements, however, are based on the implicit assumption that the frame members are continuous at the columns. There are requirements for top and bottom longitudinal reinforcement in the beam and for the spacing of beam

stirrups and column ties to ensure some ductility in the region of the beam-column joint. This framing configuration is not common to jointed precast framing with simple-span beams, but required detailing with monolithic column-beam frames. In the code development process, it was reasoned that if a precast system was to be configured in part as a monolithic frame, the engineer would most likely choose to provide the additional detailing for a special moment frame and thereby gain the advantage of the higher response modification factor (PCI, 2007).

2.2. Loads and Load Conditions for Seismic Resistant Design

2.2.1 Basic Loads Information

2.2.1.1 Dead Load

The dead loads are used to determine the effective seismic weight of the structure, W . Section 9.5.3 of ASCE7-10(ASCE7-10, 2010) defines this effective seismic weight. That definition includes the following provision: Where an allowance for partition load is included in the floor load design, the actual partition weight or a minimum weight of 10 psf of floor area, whichever is greater. For this building system, the actual partition weight has been taken as greater than the minimum allowance permitted. Detailed dead load information is shown in Table 2-1.

Table 2-1: Dead load information

Dead Load Types	Dead Load Values (psf)
24in.× 10ft wide double tee floor	47psf
Cast-in-place topping (3in. min, 3 ¹ / ₂ in.avg)	44psf
Partition allowance	20psf
Total uniform dead load	111psf

2.2.1.2 Live Load

The roof load include snow load on the flat roof with sweeping limited by parapets as well as mechanical loads in the penthouse, light metal frame roof, and snow on the penthouse roof(PCI, 2007). For simplicity in this example, these area approximately by using the floor loads. See Table 2-2 for live load details.

Table 2-2: Live load information

Live Load Types	Live Load Values (psf)
Office Loading	50 psf
Corridors	80 psf
Design average	60 psf
Reduced love load = $60 \text{ psf} \times 0.4 = 24 \text{ psf}$	

2.2.1.3 Line Load

According to PCI (PCI, 2007), line loads from inverted tee beams, spandrel beams, external columns, and internal columns are considered in this example. The details are presented in Table 2-3.

Table 2-3: Line load information

Line Load Types	Line Load Values (plf)
Inverted tee beams	1330plf
Spandrel beams	800plf
Exterior columns (24 in × 48 in)	1200psf
Interior columns (30 in × 30 in)	900psf

2.2.2 Seismic Effects Information

2.2.2.1 Seismic Coefficients

According to PCI(PCI, 2007), the mapped maximum considered earthquake (MCE) spectral response acceleration at short period and 1-second period are determined from the spectral

acceleration maps in the IBC. For the exterior section of this building system, a site in Richmond, Virginia, was assumed. The short period value, S_s , is 0.27 and the 1-second period value, S_1 , is 0.08. Without a detailed geotechnical evaluation of the site, the default site class is D. Accordingly, for Site Class D and $S_s = 0.27$, $F_a = 1.568$; for Site Class D and $S_1 = 0.08$, $F_v = 2.4$. For the interior section, a site in New York City was assumed for the purpose of determining the mapped spectral response acceleration values. The short period value, S_s , is 0.43 and the 1-second period value, S_1 , is 0.095. Without a detailed geotechnical evaluation of the site, the default site class is D. Correspondingly, for Site Class D and above values of S_s and S_1 , $F_a = 1.456$ and $F_v = 2.4$.

Detailed coefficient information is provided in Table 2-4.

Table 2-4: Coefficients in exterior section and interior section

SDC and Coefficients	Exterior Section	Interior Section
Seismic Design Category	SDC-B (Ordinary moment frame)	SDC-C (Special moment frame)
S_s	0.27	0.43
S_1	0.08	0.095
F_a	1.568	1.456
F_v	2.4	0.095
$S_{ms} = F_a \times S_a$	0.423	0.626
$S_{m1} = F_v \times S_1$	0.192	0.028
$S_{DS} = \frac{2}{3} \times S_{ms}$	0.282	0.418
$S_{D1} = \frac{2}{3} \times S_{m1}$	0.128	0.152
T_a	1.06 sec	1.06 sec
C_s	0.0401	0.0179

2.2.2.2 Lateral Loads due to the Structure Weight

The base shear is calculated by $V = C_s \times W$, and the vertical distribution of the base shear is given by $F_x = C_{vx} \times V$, where $C_{vx} = \frac{W_x \times h_x^k}{\sum_{i=1}^n W_i \times h_i^k}$. The equations are from PCI (PCI, 2007), and the detailed calculations are also shown in PCI(PCI, 2007) Chapter 4. The lateral loads due to effects of structure weight result in vertical distribution of base shear for SDC-B design and SDC-C design are shown in Table 2-5.

Table 2-5: Lateral loads due to weight for the design of SDC-B and SDC-C

Level	Vertical distribution of the base shear, F (kip)	
	SDC-B (exterior section)	SDC-C (interior section)
Penthouse	497	227
7 th	369	168
6 th	304	139
5 th	242	111
4 th	184	84
3 rd	129	59
2 nd	79	36
1 st	36	17

2.2.3 Load Conditions

The detailed calculations about seismic load combinations are shown in PCI(PCI, 2007) Chapter 4, the results of combinations are presented as follows in Table 2-6.

Table 2-6: Seismic Load Combinations for the design of SDC-B and SDC-C

Seismic Load Combinations	
SDC-B (exterior section)	SDC-C (interior section)
1.256D+E+0.5L	1.284D+E+0.5L
0.844D-E	0.816D+E

2.3. Design Details of the Building Structure

2.3.1 Design Details of Exterior Framing

As prescribed above, the exterior section of the building system is designed due to seismic design category B. Detailed design of elements dimensions and reinforcements are discussed below.

2.3.1.1 Spandrel Beams Design

The 8 ft-deep spandrel beams are designed with thickness of 9 in. However, no detailed information about reinforcements in spandrel beams is provided by PCI(PCI, 2007), thus, as a basic design, 4-#6 bars are placed at the bottom, 2-#6 bars are places at the middle, and 2-#6 bars are placed at the top. Similarly, the shear resistance is designed based on satisfying the minimum requirements, due to limited details of shear reinforcements provided by PCI Design Handbook (PCI, 2010). #4 bars are placed every 12 in with 2 legs providing shear capacity of 316 kip. Figure 2-2 provides reinforcement details in spandrel beam cross section.

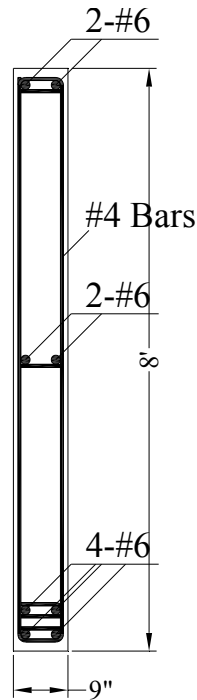

Figure 2-2: Spandrel beam cross section

2.3.1.2 External Columns Design

The column cross-section is a rectangular of 24in \times 48in. At the first level, the column is blocked-out on the corners to make room for the spandrel beam bearings. At the first let-in portion of the column above the base, a biaxial interaction checking is made by PCI using combination forces representative of this level with 8-#10 bars. Reinforcement in the column is laid out with consideration for the changes in cross section for the beam connection pocket. Figure 2-3 shows the external column section at let-in for beam bearings. At the base, as shown in Figure 2-4, the longitudinal bars are placed so that most bars will run continuously in the reduced section. Bars in the corners under the beam bearing block-outs are the same size as the main continuous bears since the axial load at the base requires them. At the upper levels, bars in the position between the pockets are the same.

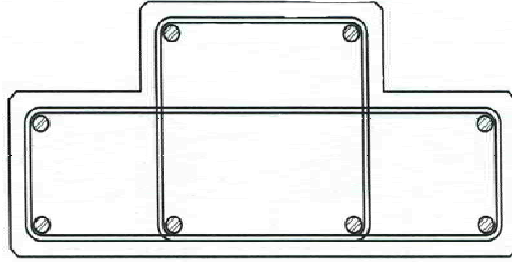

Figure 2-3: Exterior column section at let-in for beam bearings (PCI, 2007)

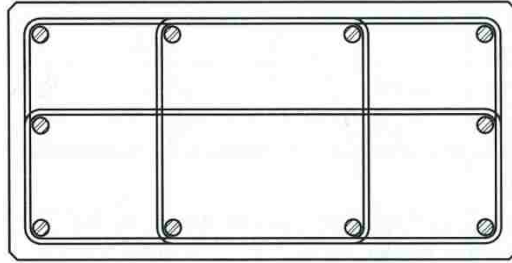

Figure 2-4: Exterior column section at base (PCI, 2007)

2.3.1.3 *Beam-to-Column Connections Design*

The forces in the beam-to-column frame connection require the equivalent of a connection plates $\frac{3}{4}$ in \times 8in with $f_{yt} = 36$ ksi in tension. The top and bottom steel plate connections are spacing 6 ft apart, as shown in Figure 2-5. A typical design for the spandrel beams as simply supported includes four $\frac{3}{4}$ in. strands near the bottom and two $\frac{3}{4}$ in. strands near mid-height for handling and crack control. The anchorage bars for the connection assembly are 3-#9 bars to be sufficient to develop the connection force. These bars are projecting into the length of the beam sufficient for development as a Class B splice. 3-#9 bars with end hooks are placed to match the tail bars from the connection assembly (PCI, 2007). Figure 2-6 provides the details in spandrel-to-column connections.

The beam-to-column link is also designed to accommodate the out-of-plane torsion connection of the spandrel beam to the column, as well as the congestion of column and beam reinforcement. The torsion connection for spandrel beams is commonly made with

high-strength rods through sleeves in the beams and into inserts in the column. These connections are made in addition to the frame connections to provide for an immediate erection connection and for a connection that is stiff for the out-of-plane action (PCI, 2007).

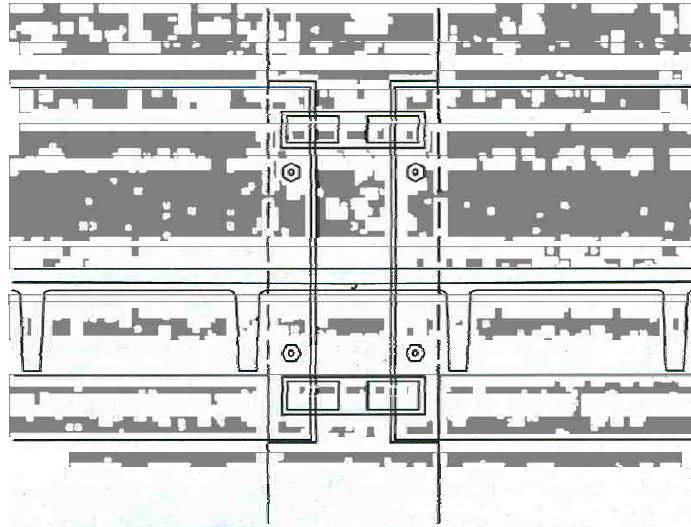

Figure 2-5: Spandrel-to-column assembly (PCI, 2007)

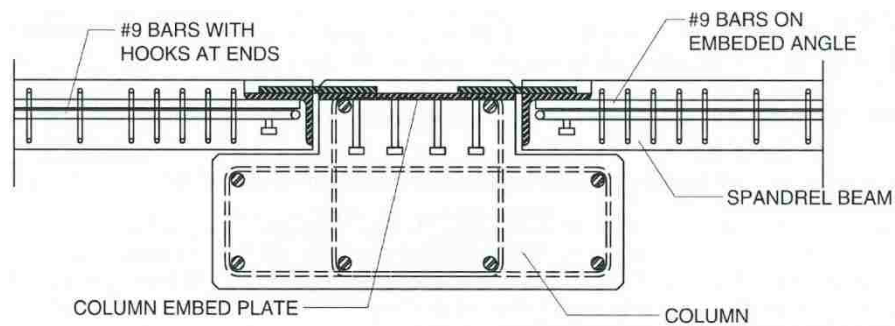

Figure 2-6: Details in spandrel-to-column connection (PCI, 2007)

2.3.2 Design Details of Interior Framing

The internal frame design is utilizing six independent H-frame stacks. The frames are located on the plan in Figure 2-7. These frames are made of inverted tee beams between two columns. The splices are located at mid-height between the floors. The outside frames include overhanging inverted tee beams toward the building ends. For this building system, the

concrete is normal-weight, $W_c = 150\text{pcf}$, with $f'_c = 6000\text{psi}$. The steel reinforcement has a yield strength, f_y , equal to 60000psi (PCI, 2007).

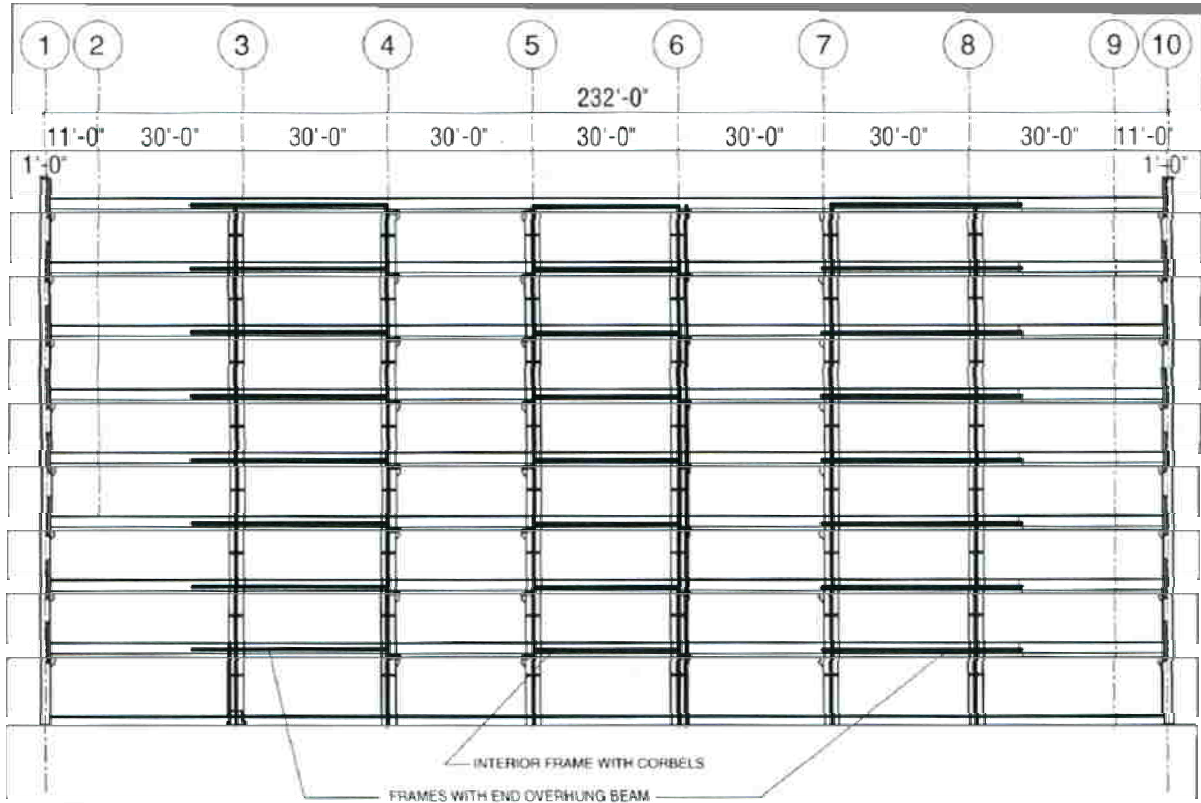

Figure 2-7: Interior section of special moment frame from SDC-C (PCI, 2007)

2.3.2.1 Inverted Tee Beams Design

From the frame analysis of PCI (PCI, 2007), the inverted tee beams are 30 in wide at the stems to match the width of the columns. The beam ledges project 8 in beyond the stems on both sides and have height to support the 24 in-deep double-tee floor framing without daps. The beams at the upper levels are 36 in deep, but at floor levels 1 through 3 they are 42 in-deep, as required for the stiffness of the frame. The details of the inverted tee beams are illustrated in Figure 2-8 through Figure 2-13.

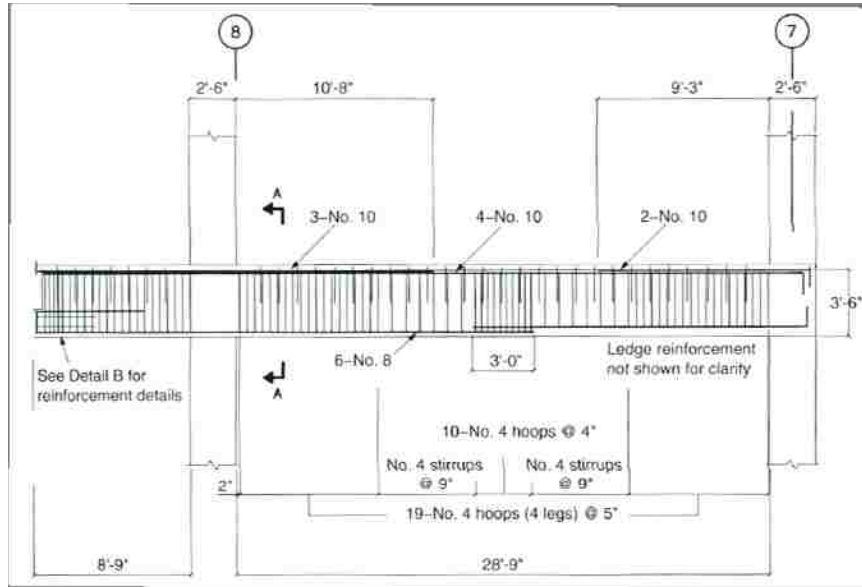

Figure 2-8: Reinforcement details about overhung frames (PCI, 2007)

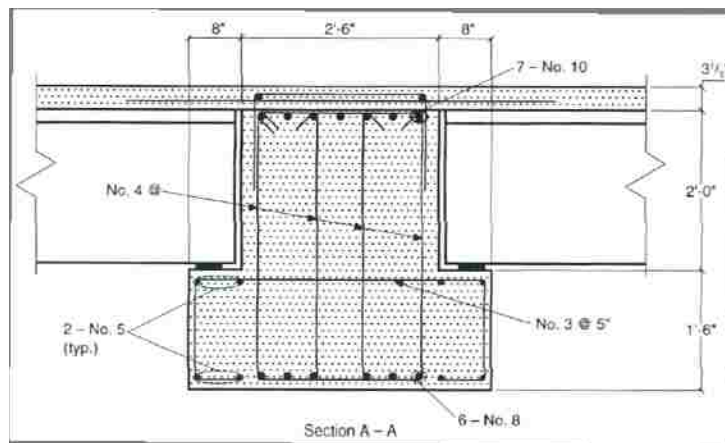

Figure 2-9: Reinforcement details in inverted tee beam cross section at the first floor level (PCI, 2007)

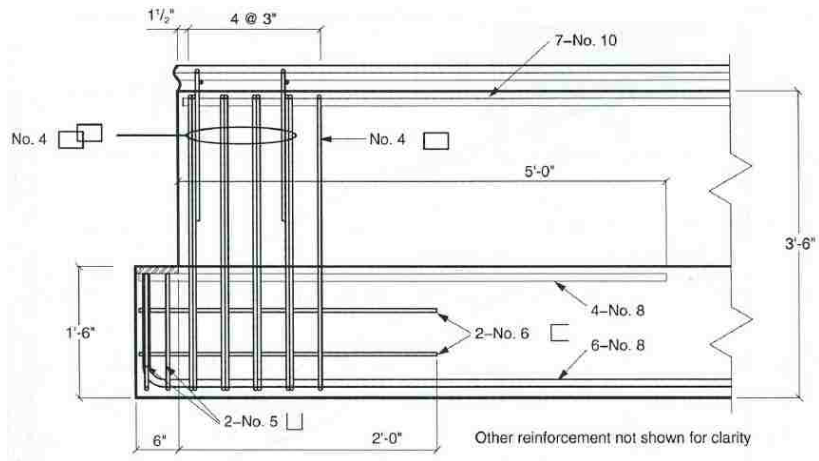

Figure 2-10: Reinforcement details in overhung part of overhung frame (PCI, 2007)

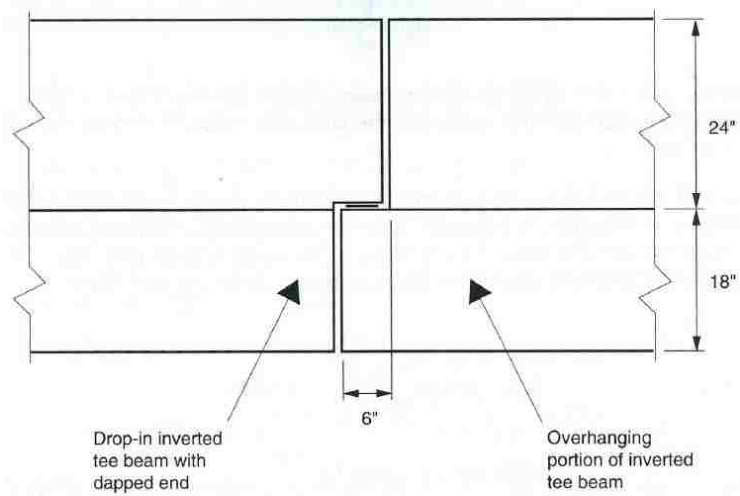

Figure 2-11: Connection between drop-in inverted tee beam and overhanging portion of inverted tee beam (PCI, 2007)

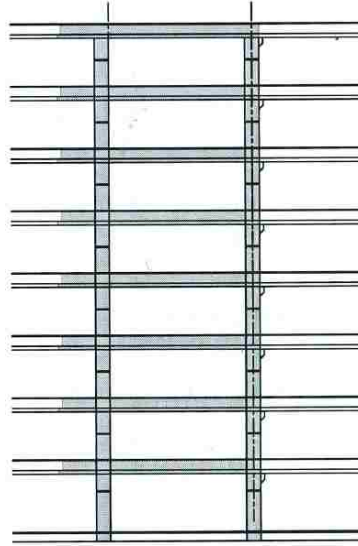

Figure 2-12: Elevation of outside overhung frames (PCI, 2007)

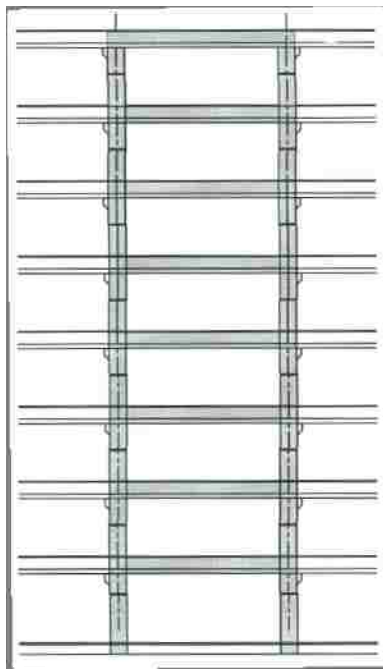

Figure 2-13: Elevation of inside frame (PCI, 2007)

2.3.2.2 Internal Columns Design

Based on the load combinations, a 30in \times 30in column using concrete with f'_c of 7000 psi requires 8-#11 bars to satisfy the axial load demand at the first floor. The flexural requirement is also satisfied by 8-#11 bars. #5 hoops and #4 crossties at 4 in spacing are

provided for the transverse reinforcement at the column base and at the joints with 8-#11 longitudinal bars. Reinforcement's details in internal column are illustrated in Figure 2-14. Figure 2-15 shows the reinforcement details of column-to-column connection in interior section.

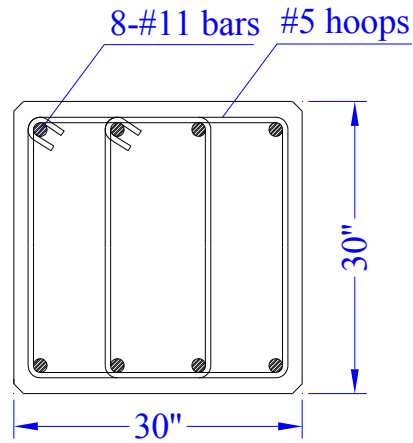

Figure 2-14: Reinforcements in column cross section of interior section

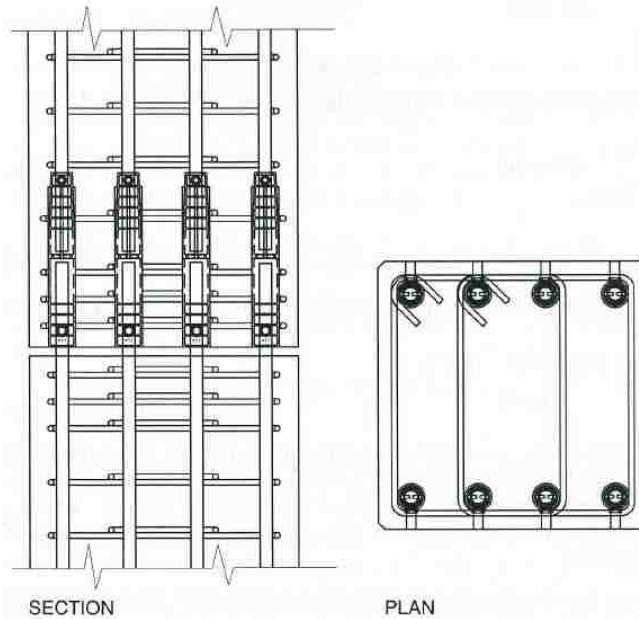

Figure 2-15: Reinforcement details for interior column-to-column connection (PCI, 2007)

3. THREAT EVALUATION DUE TO BOMBING

The potential for column loss due to high explosive detonation near the prototype building is examined in this chapter. The columns are examined for three failure modes: Flexural failure, shear failure, and brisance failure. The potential for multiple column loss as a result of these failure modes is examined.

3.1. Column Capacity

3.1.1 Column Moment Capacity

The column sections are based on the eight-floor office building details presented in the design example of PCI Handbook of Seismic Design of Precast/Prestressed Concrete Structures. The exterior columns at the first floor are rectangular and measure 24in \times 48in in section, except the corner sections. The corner columns have additional corner “return” section making an L-shape 36 in long. For simplicity, L-shape columns are replaced by rectangular columns in threat evaluation. As described in Section 2.3.1.2, the column at the first level is blocked-out on the corners to make room for the spandrel beam bearings. At the first let-in portion of the column above the base, a biaxial interaction checking is made by PCI using combination forces representative of this level with 8-#10 bars, and the nominal moment capacity of the block-outs section is 888.8 kip-ft. Reinforcement in the column is laid out with consideration for the changes in cross section for the beam connection pocket. The external column section at let-in for beam bearings is illustrated in Figure 3-1. The area of one #10 bar is 1.56in², and its diameter is 1.41in. The cover from the edge of the column cross-section to the surface of the bars is 1.5in. At the base, also shown in Figure 3-1, the longitudinal bars are placed so that most bars will run continuously in the reduced section. Bars in the corners under the beam bearing block-outs are the same size as the main

continuous bars since the axial load at the base requires them. At the upper levels, bars in the position between the pockets are the same. To evaluate reinforcing steel dynamic strength, according to UFC-3-34-02 (UFC-3-340-02, 2008), an increase factor of 1.2 is assumed because it is the product of dynamic increase factor and strength increase factor, which is 1.17 and 1.1, respectively. As a result the dynamic nominal moment capacity is 1067 kip-ft. The dynamic nominal moment capacity of the rectangular section is 1163 kip-ft at the mid-height and the bottom. The concrete strength at the first level is assumed to be 8000 psi. Since the columns and beams are connected by steel plates, which are able to provide moment resistance as described in Section 2.3.1.3, the columns are simulated as rigid connected.

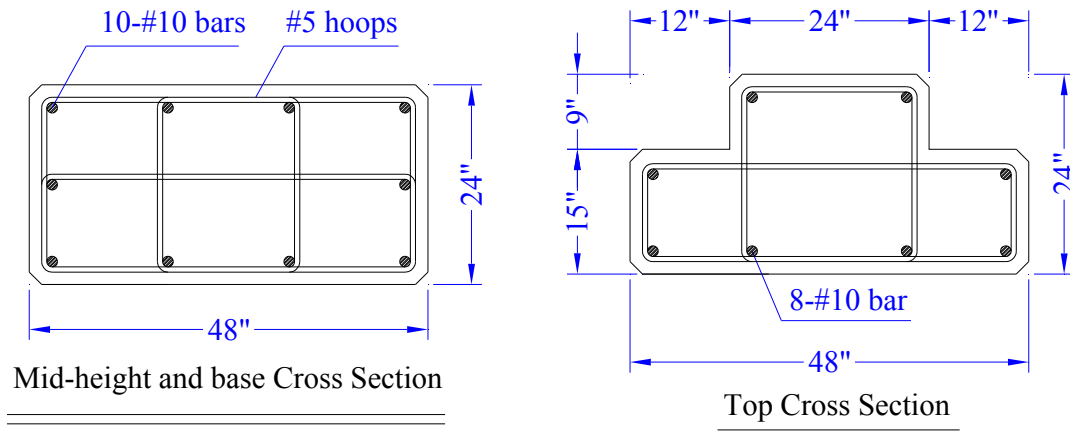

Figure 3-1: Column cross-sections

The deformations of the columns under uniform blast loads are computed. The deflections are evaluated elastically on the full column width by the effective moment of inertia I_e which provides a transition between the gross section moment of inertia I_g and the cracked section

moment of inertia I_{cr} . According to (ACI318-08, 2008) Section 9.5.2.3, $I_e = \left(\frac{M_{cr}}{M_a} \right)^3 \times$

$I_g + \left[1 - \left(\frac{M_{cr}}{M_a} \right)^3 \right] \times I_{cr}$, approximately, for the part below the block-out section,

$I_e = 0.8 \times I_g = 0.8 \times 5.53 \times 10^4 \text{in}^4 = 4.42 \times 10^4 \text{in}^4$. The effective moment inertia of the block-out section is less than $4.42 \times 10^4 \text{in}^4$, but the effects due to the difference is so small that can be ignores. Therefore, $I_e = 4.42 \times 10^4 \text{in}^4$ is used as the effective moment inertia of the column in the following deflection calculations. As described previously, the height of column at first level is $H = 15\text{ft}$, and the width $w = 4\text{ft}$. The concrete modulus E_c is 4696 ksi by equation $E_c = 33 \times \gamma_c \times \sqrt{f_c}$, where $\gamma_c = 150 \text{lb}/\text{ft}^3$, and $f_c = 6000\text{ksi}$.

The spacing between columns is 30ft and 49 ft, in the longitudinal and transverse direction, respectively. In this report, only the columns in the longitudinal directions are considered. The same methods can be followed in threat evaluation for transverse direction columns. For the moment capacity evaluation, the column is simulated as fixed-end, subjected to the uniformly distributed pressure due to blast load and the hinge forms when the normal dynamic moment capacity is exceeded. The dynamic nominal moment capacity at the top section (block-outs section) of the column is $M_{\text{top}} = 1057 \text{kip} - \text{ft}$, it is $M_{\text{mid-bot}} = 1163 \text{kip} - \text{ft}$ below the block-outs section. The effective moment inertia is $I_e = 4.42 \times 10^4 \text{in}^4$.

3.1.1.1 Step 1: First Hinge Formation

When the reflected pressure R applied on the fixed-fixed column increases to 197.5 psi, the block-outs section reaches its dynamic nominal moment capacity M_{top} first by using

equation $\omega = \frac{M_{\text{top}} \times 12}{w \times H^2}$, where ω is uniformly distributed load, and the corresponding deflection at mid-height Δ is 0.062 in through $\Delta = \frac{\omega \times L^4}{384 \times E_c \times I_e}$.

3.1.1.2 Step 2: Second Hinge Formation

After the first hinge formation, the column is fixed at the bottom and pinned at the top. In comparison of moment response at mid-height and bottom, the second hinge forms at the bottom, and the increment of uniform load is calculated by $\omega = \frac{M_{\text{mid-bot}} \times 8}{w \times H^2}$. In addition to the uniform load calculated in step 1, the uniform load applied on the column at the second hinge formation is 209.4 psi. The increment of mid-height deflection is calculated by $\Delta = \frac{\omega \times L^4}{192 \times E_c \times I_e}$, therefore the total mid-height deflection at two-hinge formation reaches to 0.07 in.

3.1.1.3 Step 3: Third Hinge Formation

The column is changed as simply supported since two hinges formed at the top and bottom of the column. $\omega = \frac{M_{\text{mid-bot}} \times 8}{w \times H^2}$ is used to calculate the uniform load increment until the third hinge formation completed at the mid-height. The total uniform load applied at the column in completion of three-hinge formation is increasing to 281.71 kip. The increment of mid-height deflection is evaluated by $\Delta = \frac{5\omega \times L^4}{384 \times E_c \times I_e}$, therefore, the total deflection at mid-height is 0.183 in.

Figure 3-2 shows the resistance-displacement history of the column. Table 3-1 provides the values of deflection at mid-height and uniform load applied on the column at different stages of hinge formation.

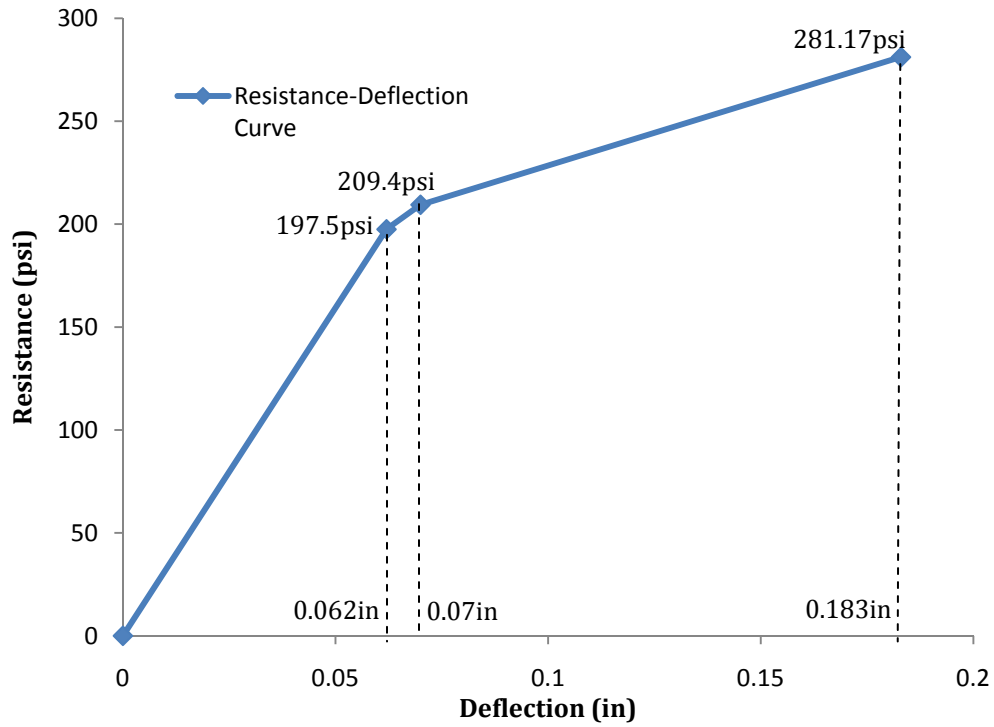

Figure 3-2: Resistance function column cross section

Table 3-1: Resistance-deflection relationship

R-Calculation Equation	$\omega = M_{top} \times 12 / w \times H^2$	$\omega = M_{mid-bot} \times 8 / w \times H^2$	$\omega = M_{mid-bot} \times 8 / w \times H^2$	
R(psi)	0	197.5	209.4	281.17
Δ -Calculation Equation	$\Delta = \omega \times L^4 / 384 \times E_c \times I_e$	$\Delta = \omega \times L^4 / 192 \times E_c \times I_e$	$\Delta = 5\omega \times L^4 / 384 \times E_c \times I_e$	
Δ (in)	0	0.062	0.07	0.183
Hinge Formation	No	Top	Bottom	Mid-height

3.1.2 Column Shear Capacity

The column shear capacity evaluation is mainly used for the case of direct shear failure, based on the static analysis, where the pressure applied on the column is uniformly distributed and no time-history effects were considered. According to PCI-Blast Design of Precast/Prestressed Concrete Components Section 4-1.1, typically, for concrete a dynamic increase factor of 1.1 is used for the strength calculation. In simplification of modeling, the column is simulated as a fixed-fixed end vertical element subjected to uniform load. The cross section of column in exterior section is 24in \times 48in of rectangular and the pressure is applied on the face of 48 in side of the column. Generally, the direct shear is resisted by diagonal transverse reinforcement, not horizontal transverse bars. In this example, however, no diagonal tension bars are provided. The resistance to direct shear is assumed to be provided by the concrete only. According to UFC 3-340-02 Section 4-19.2(UFC-3-340-02, 2008), the ultimate shear force resisted by the concrete is $V_d = 0.16 \times f_{dc}' \times b \times d$, where f_{dc}' is the dynamic concrete strength of 6600psi, b and d is the cross section width and depth, equal to 24 in and 48 in, respectively. Consequently, the dynamic shear capacity determined by the concrete is 1216.5 kip at both ends. The image of shear damaged condition is illustrated in Figure 3-3.

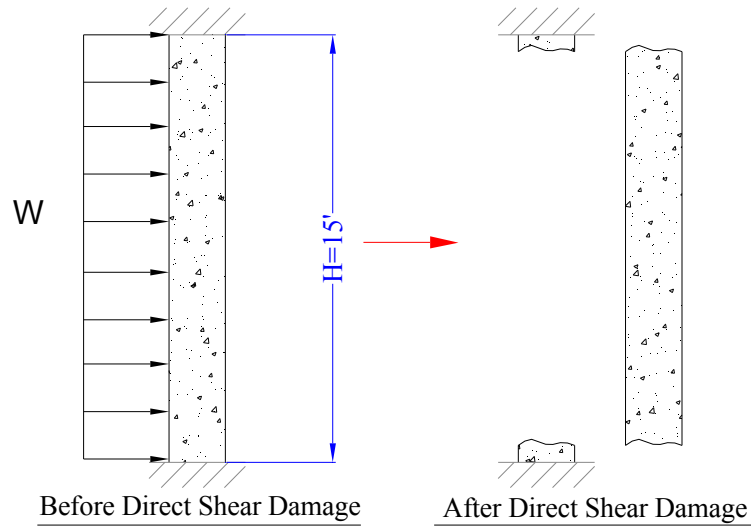

Figure 3-3: Shear damaged condition

3.2. Failure Cases Introduction

3.2.1 Brisance Failure (Close-in Design)

For Brisance Failure the scaled resistant distance Z shall be no greater than $1.5 \frac{\text{ft}}{\text{lb}^{\frac{1}{3}}}$, which means the column will be damaged instantaneously without consideration of dynamic effects (Paul, W, Mete, & Charles, 1998). Thus, only two factors are needed: the range from detonation to the column, R , and the weight of charge, W . The standoff distance of safe-range from the detonation to the column was determined by $R = Z \times W^{\frac{1}{3}}$. A number of explosive sizes are examined; they include 500lb, 1000lb, 2000lb, 8000lb and 10000lb of TNT. Therefore, the standoff distance R can be calculated directly by $R = Z \times W^{\frac{1}{3}}$ with $Z = 1.5 \frac{\text{ft}}{\text{lb}^{\frac{1}{3}}}$ as critical condition under different weight of charge.

3.2.2 Flexural Failure (Far Field Design)

Flexural failure is developed under the consideration of $Z \geq 3.0 \frac{\text{ft}}{\text{lb}^{\frac{1}{3}}}$ and is considered a far field design (UFC-3-340-02, 2008). Flexural failure is defined to occur when the dynamic response of the column results in a deformation in excess of 10 degrees of support rotation. To determine at what demand this occurs the system is simplified to a single degree of freedom (SDOF) system and analyzed dynamically. , and the Resistance-Displacement Relationship is determined by the deflection at mid-height. The load is uniformly distributed on the width side of column, and the first hinge forms at the top of the column as presented in Table 3-1. With the distributed load increasing, the second hinge forms at the bottom, then the third one forms at the mid-height. The mid-height deflection reaches 0.183 in when three-hinge formation completed. The structure is an office building which for this study is classified in a medium level of protection. Under this LOP the column is considered to fail when the support rotation exceeds 10 degrees, consequently, the mid-height deflection shall be no less than 15.8 in, which is far beyond 0.183 in. Thus, the column fails after three-hinge formation. The deflection is calculated based on dynamic analysis. For flexural failure, shear effects are not considered so that the column failure is only evaluated on flexural damage.

3.2.3 Direct Shear Failure (Far Field Design)

According to UFC 3-340-02 Section 4-19.2, direct shear failure of a member is characterized by the rapid propagation of a horizontal crack through the width of the member; this crack is usually located at the supports where the maximum shear stress occurs. Failure of this type is possible even in members reinforced for diagonal tension. This case occurs when $Z \geq 1.5 \frac{\text{ft}}{\text{lb}^{\frac{1}{3}}}$.

Since no diagonal shear reinforcement is used the ultimate shear force is resisted by the

concrete only. Once the direct shear strength is exceeded, the column is removed immediately from the supports.

3.3. Failure Cases Analysis

The three failure modes are examined under five explosive weight levels. These charge sizes represent package-sized to large vehicle borne explosive charges.

3.3.1 Brisance Failure (BF)

Due to the characteristics of brisance, failure under this condition can be assumed to act instantly. Consequently, there is no need to consider the dynamic effects applied on the column. The safe-range is only related to the scaled distance Z and the weight of charge W , as previous discussed. Table 3-2 below presents the number of failed columns corresponding to the selected weight of charge and the standoff distance.

Table 3-2: Columns failure condition due to Brisance Failure

W	500lb	1000lb	2000lb	8,000lb	10,000lb
R	11.906ft	15.00ft	18.899ft	30.00ft	32.317ft
Maximum Number of columns failure	1	2	2	3	3

The following section is about details and discussions for each charge case.

3.3.1.1 $W=500lb$

Under this condition, only one column would be damaged if the detonation was placed within the lined area. Otherwise, no columns would be damaged. Figure 3-4 provides the image of blast load effects under this condition.

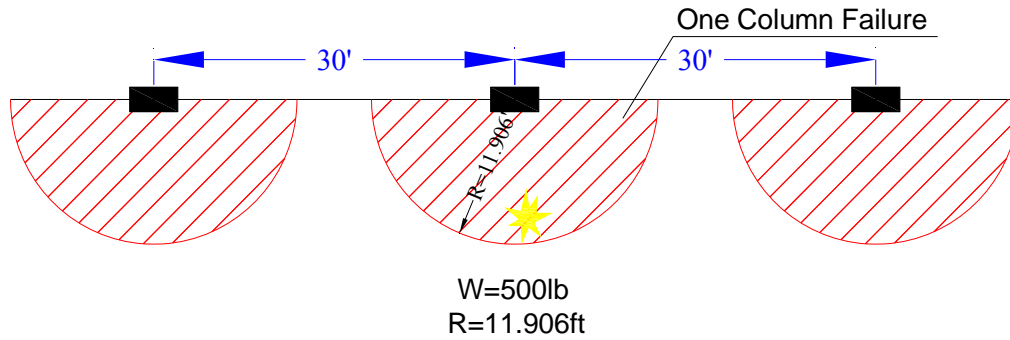

Figure 3-4: Blast load effects due to Brisance Failure at $W=500\text{lb}$

3.3.1.2 $W=1000\text{lb}$

As Figure 3-5 shown, it is a critical condition that two columns would be failed if the detonation was just located at the center between two columns. Otherwise, only one column would be failed when the charge was placed in the lined area, and on failure existed for the location beyond the lined area.

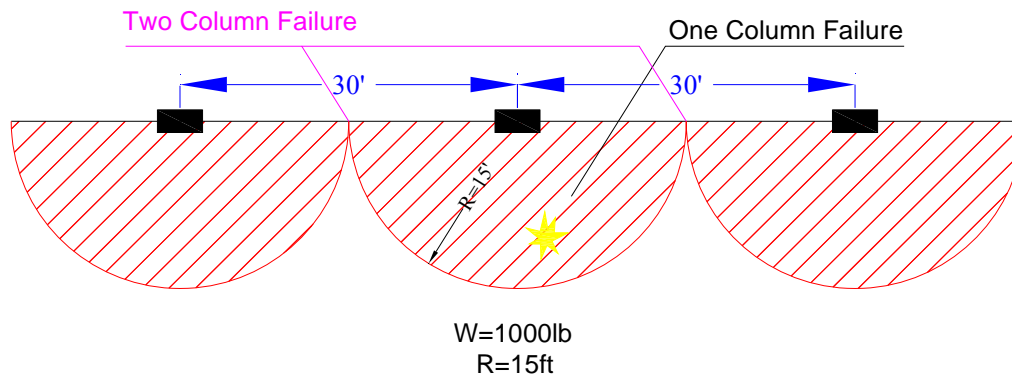

Figure 3-5: Blast load effects due to Brisance Failure at $W=1000\text{lb}$

3.3.1.3 $W=2000\text{lb}$

Two columns will be fail when the detonation is placed within the solid area. Similar as above, in the lined area, only one column fails and no failure occurs for the rest region, as shown in Figure 3-6.

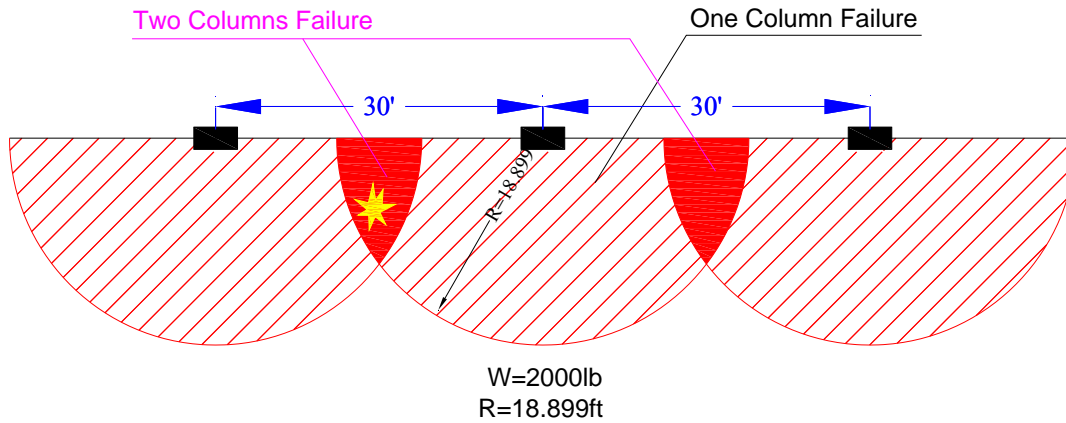

Figure 3-6: Blats load effects due to Brisance Failure at $W=2000lb$

3.3.1.4 $W=8000lb$

Figure 3-7 illustrates another critical condition that three columns will be damaged if the charge explodes right at columns' sites. Although it seems impossible in real case, it provides an important condition to determine the number of columns failed. Similar as the condition of $W=1000lb$, two columns failure will happen when the detonation is placed in the solid area, one failure would occur for the shaded area.

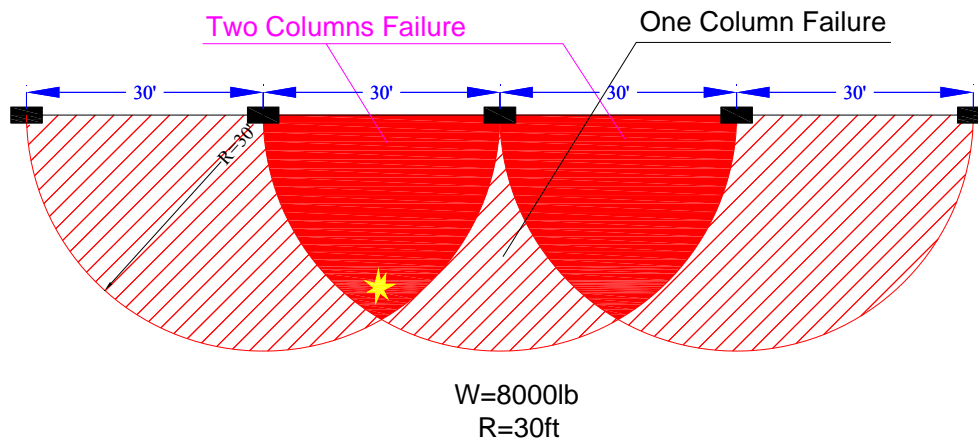

Figure 3-7: Blast load effects due to Brisance Failure at $W=8000lb$

3.3.1.5 $W=10000lb$

It is the most severe case among these five conditions. As shown in Figure 3-8, if the charge is placed within the zigzagged area, three columns will fail due to brisance. Two columns will fail if the charge is placed in the solid region and one column failure will occur in the lined area.

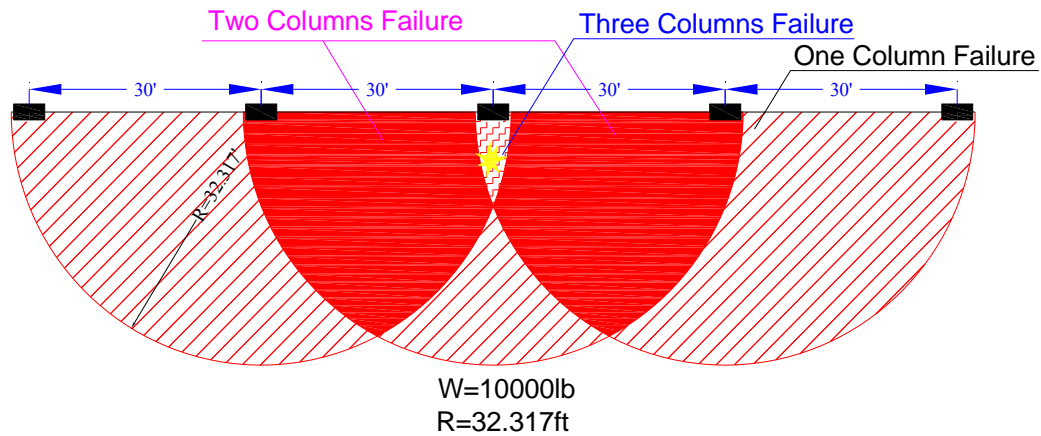

Figure 3-8: Blast load effects due to Brisance Failure at $W=10000lb$

3.3.1.6 Comparison

For Brisance Failure with $Z = 1.5 \frac{ft}{lb^{\frac{1}{3}}}$, the safe-range is related to the weight of charge. From the figure, it is obvious that heavier charge results in more severe damage to columns, so the range of the charge effects is increasing. The most severe condition might occur with three columns failure when the charge is 10,000lb of TNT. Through the two critical conditions, the number of failed columns can be determined, if the weight of charge was given. See details in Figure 3-9.

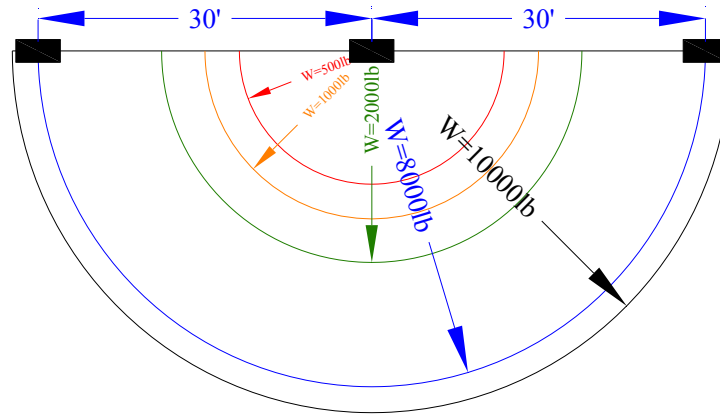

Figure 3-9: Comparison of blast load effects due to Brisance Failure

3.3.2 Flexural Failure (FF)

Flexural failure is determined by the uniform pressure applied on the front face of the column. Rebound effects are not considered. Figure 3-10 illustrates the directly applied load on the column front face. Based on the analysis, the maximum deflection at the mid-height of the column is approximately 0.183 in even when $W=10000\text{lb}$. Under this condition, three-hinges have formed along the column, but the corresponding deflection is not great enough to achieve the failure displacement 15.8 in. According to previous analysis of column flexural capacity, when the column is considered as failure, the support rotation shall be at least 10 degrees. Herein, the height of the column is 15ft and the failure deflection at the mid-height shall be greater than 15.8 in, which is much greater than 0.183 in. Due to the small tributary area of the column, the deflections are minimal under the largest blast demand. The majority of the pressure passes through the spacing between columns.

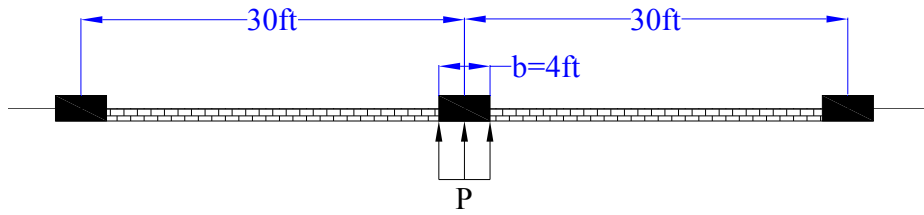

Figure 3-10: Blast load applied on the column

However, if a wall was connected to the columns, then the effects from wall as a transmitter is introduced. As shown in Figure 3-11, the pressure applied on the 30ft length wall will be transferred directly to the column, and increasing the failure potential. While the prototype building does not include such a wall system the assumption is made that a wall is present. This would provide the worse case scenario against a potential detonation. The tributary wall is conservatively assumed to contribute no flexural resistance or mass to the structure under blast load. Since the column width is 48 in, the pressure on the column is multiplied by $30\text{ft}/48\text{ft}$, which is equal to 7.5 times the original pressure. Consequently, the column failures might have more potential to occur due to flexural damage. For simplicity the assumption is also made that the flexural resistance is only provided by the weak axis bending, irrespective of the detonation location. This assumption neglects the reduction in pressure demands due to an angle of incidence between the explosive and the column. While this may be overly conservative it provides a means for determining a safe standoff for the columns under flexural demands.

Three weights of charge ($W=3250$ lb of TNT, $W=5000$ lb of TNT and $W=7000$ lb of TNT) are considered with details demonstrated below.

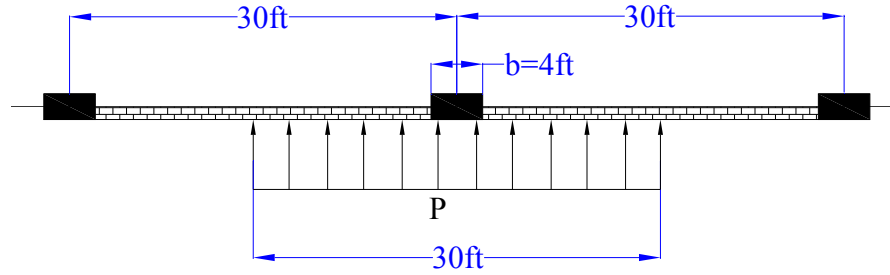

Figure 3-11: Blast load applied on the walls

3.3.2.1 $W=3250lb$

The critical condition for flexural failure occurs when $Z = 3.0 \frac{ft}{lb^{\frac{1}{3}}}$, the reflected pressure P_r and scaled impulse i_r can be read directly from Figure 2-15 of UFC-3-340-02. Since the dynamic effects resulting in the exceeded deformation are related to impulse and reflected pressure, the weight of charge at this condition is determined when the mid-height deflection is greater than 15.8 in, which is 3250 lb of TNT. In other words, no matter how much close the charge located to the column within the flexural damage region, it is not able to result in flexural failure with any weight of detonation less than 3250 lb of TNT. Based on this situation, the standoff distance is 44.44 ft, as shown in Figure 3-12. Similarly as Brisance Failure, common area enclosed by semi-circles with 44.44 ft of radius represents the region of more than one column failure. The shaded area indicates the region, where the charge is located, is leading to three columns failure. In the lined area, two columns will be damaged by flexural failure.

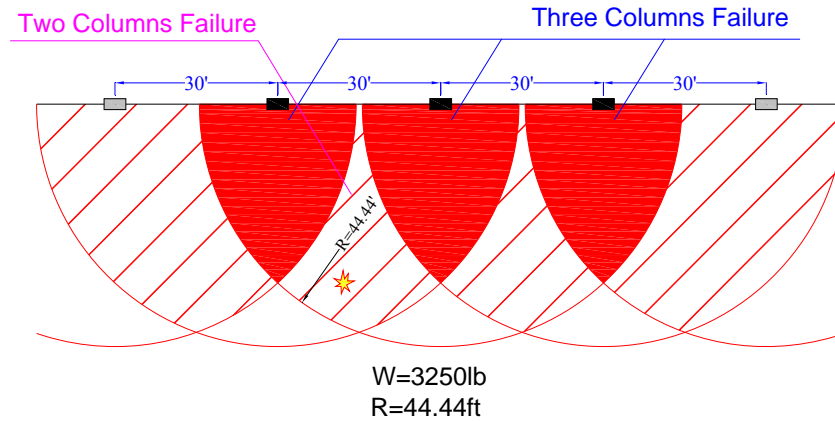

Figure 3-12: Blast load effects due to Flexural Failure at $W=3250\text{lb}$

3.3.2.2 $W=5000\text{lb}$

Under this weight, more than three columns in longitudinal direction will fail at the same time, when the charge is in the zigzagged area. The safe-range is 56.94 ft, but the spacing of two columns is just 30 ft. As a result up to 3 columns could fail as a result of the blast demand.

On the other hand, the spacing of two columns in the transverse direction is 49 ft, compared with longitudinal spacing of 30 ft, thus, more pressure transferred from walls will exert on the columns. The columns in the transverse direction are more likely to be damaged than in longitudinal direction, under the same condition of charge weight and safe-range. Consequently, if the charge has no change, then greater standoff distance of charge from the column is required to specify the safe-range. With the calculation of SDOF System of transverse direction column, the standoff distance is about 83 ft, which is approximately 1.5 times greater than longitudinal direction. Since the spacing ratio of transverse column to longitudinal column is about 1.6, the diagram of safe-range in transverse is roughly proportional to that in longitudinal. Additionally, the columns in the longitudinal direction are much more than in transverse direction and the frame behavior for longitudinal direction

is considered more significantly. Consequently, this figure can be applied for both directions approximately. Figure 3-13 illustrates the blast load effects when the weight of charge is 5000 lb of TNT.

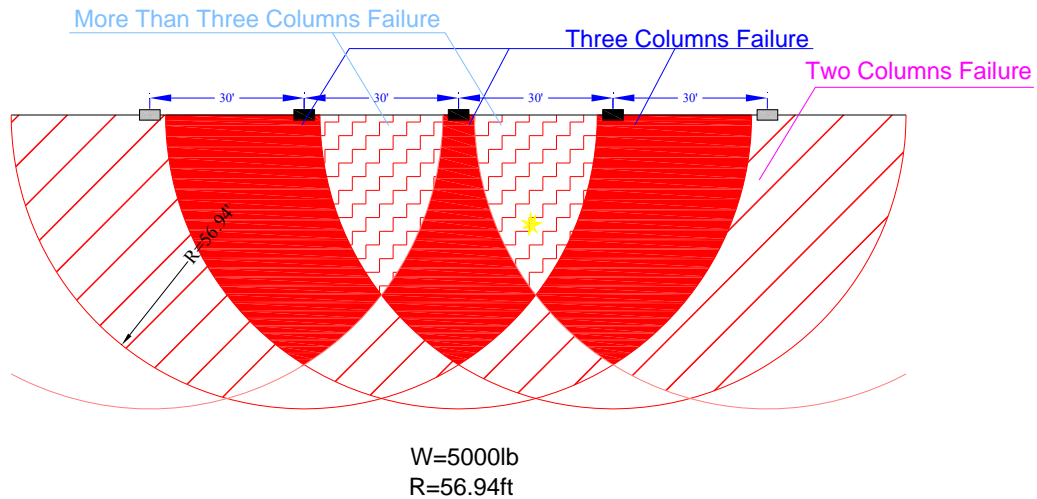

Figure 3-13: Blast load effects due to Flexural Failure at W=5000lb

3.3.2.3 W=7000lb

With the increasing weight of charge, greater distance from column to charge is required to satisfy the safe-range, which is 69.25 ft. The greater common area indicates that the potential of more columns failure is increasing. For the same reason as W=5000 lb, the transverse safe-range situation can also be represented by the longitudinal diagram. The common region and the number of column failure details are presented in Figure 3-14.

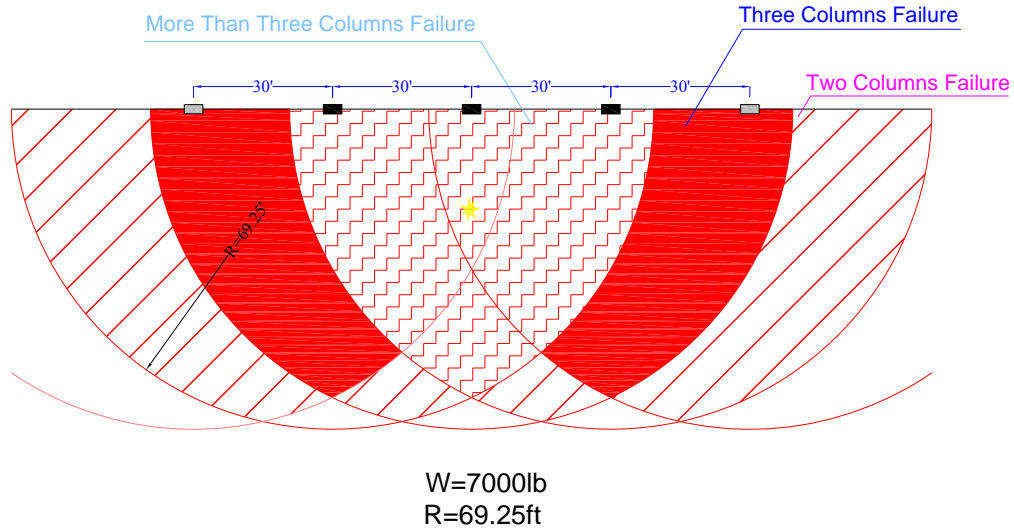

Figure 3-14: Blast load effects due to Flexural Failure at $W=7000\text{lb}$

3.3.2.4 Comparison

Based on three cases analysis above, other two weights of charge are added in this section. Similarly as Brisance Failure, the safe-range under different weights of charge for Flexural Failure are presented in Figure 3-15. In this figure, the greatest standoff distance is required when the charge weight is equal to 10000 lb of TNT. The minimum distance of 44.44 ft is corresponding to the lowest charge weight of 3250 lb of TNT, which is also the critical weight resulting flexural failure. By utilizing the same methods, the stand-off ranges under effects of 9000 lb of TNT and 10000 lb of TNT are illustrated in the following figure.

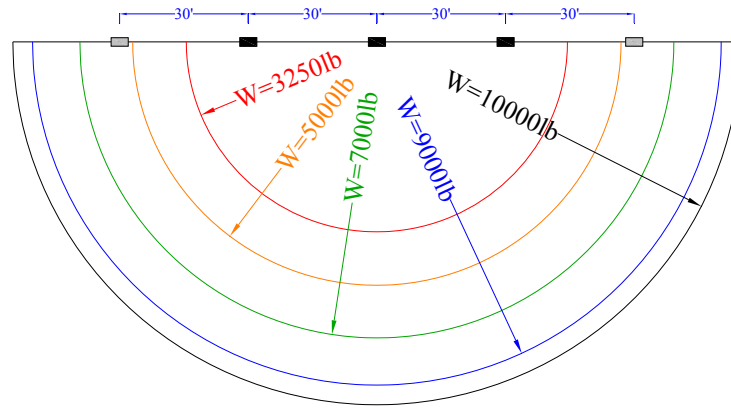

Figure 3-15: Comparison of blast load effects due to Flexural Failure

3.3.3 Direct Shear Failure (DSF)

Since no diagonal tension bars placed in the column, the direct shear resistance is provided by concrete. As described previously, the concrete shear resistance is 1216.5 kip. The demands from a blast result in a dynamic shear reaction at each end of the column as follows: $V = C_r \times R(t) + C_p \times P(t)$. Looking at the initial application of load at time zero the $R(t)$ goes to zero and the $P(t)$ goes to the reflected pressure P_r over the column. The C_p value for a fixed-fixed uniformly loaded column is 0.14. Since the width of the rectangular cross section is 4 ft, the load resulted from reflected pressure can be calculated by $L = 4\text{ft} \times 15\text{ft} \times P_r$. The load is supported by the shear capacity of concrete, and the ultimate reflected pressure is $P_r = \frac{1216.5\text{kip} \times 2}{4\text{ft} \times 15\text{ft}(0.14)} = 2014\text{psi}$. Therefore, safe-range standoff and column failure number corresponding to various weight of charge can be determined. This calculation is based on the column only and the no wall element is assumed to exist. This failure case takes two examples with charge weight of 500 lb of TNT and 5000 lb of TNT.

3.3.3.1 $W=500lb$

Compared with Brisance Failure of the same weight of charge, the safe-range for Direct Shear Failure is 16.25 ft, greater than 11.9 ft. In the longitudinal direction, where the spacing of columns is 30 ft, this standoff distance results in three columns failure region. Since the critical weight of charge for Flexural Failure exceeds 500 lb of TNT, Direct Shear Failure provides the greater safe-range. Moreover, no column would be failed if the detonation exploded beyond the region enclosed by semi-circle with radius of standoff distance, so that safe-range is considered as the upper bound of standoff distance of charge from the column. See details in Figure 3-16.

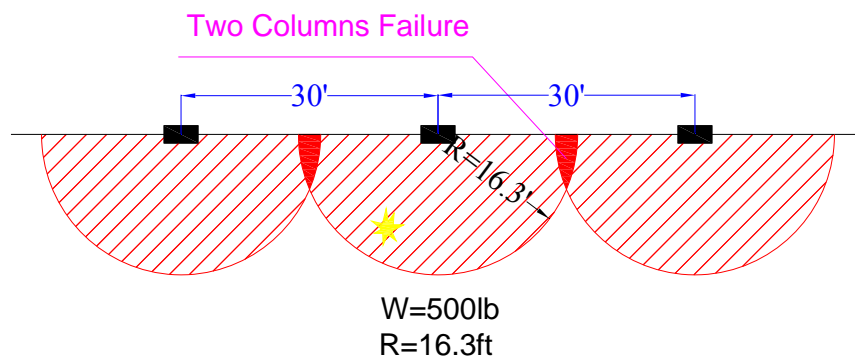

Figure 3-16: Blast load effects due to Direct Shear Failure at $W=500lb$

3.3.3.2 $W=5000lb$

In comparison with Flexural Failure case, where the safe-range is 56.94 ft respect to 5000 lb of TNT charge weight, the standoff distance for Direct Shear Failure is 35.00 ft. If the charge is located within the region enclosed by two semi-circles taking 35 ft as radius, Direct Shear Failure will control the column damage. However, if the explosion occurs within the safe-range of 56.94 ft, but beyond 35 ft, the column will be failed depending on Brisance Failure or Flexural Failure. The number of failed columns and the corresponding stand-off ranges

due to Direct Shear Failure are detailed in Please note the effects of Brisance Failure and Flexural Failure are not shown in Figure 3-17.

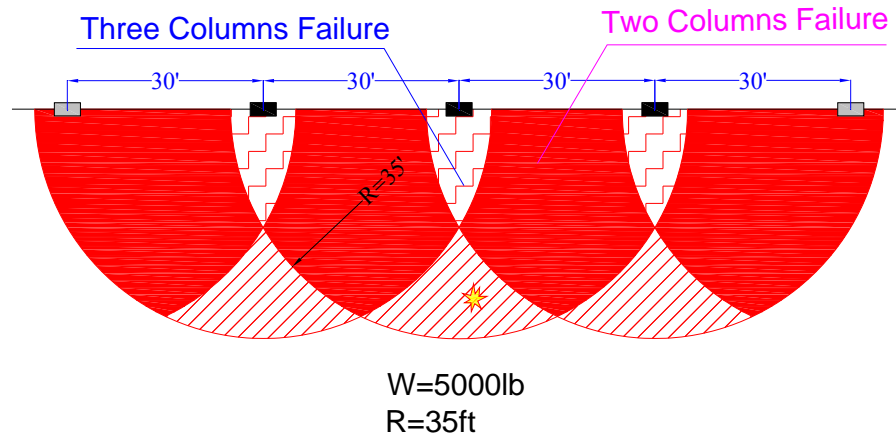

Figure 3-17: Blast load effects due to Direct Shear Failure at W=5000lb

3.3.3.3 Comparison

Based on above three cases analysis, other three weights of charge are added in this section. Similarly as previously discussed, the safe-range respective to weights of charge for Direct Shear Failure are presented in Figure 3-18. In this figure, the greatest standoff distance of 40.9 ft is required when the charge weight is equal to 8000 lb of TNT. The minimum distance of 16.3 ft is corresponding to the lowest charge weight of 500 lb of TNT. By utilizing the same methods, the stand-off ranges under effects of 1000 lb of TNT, 2000 lb of TNT, and 10000 lb of TNT are illustrated in the following figure.

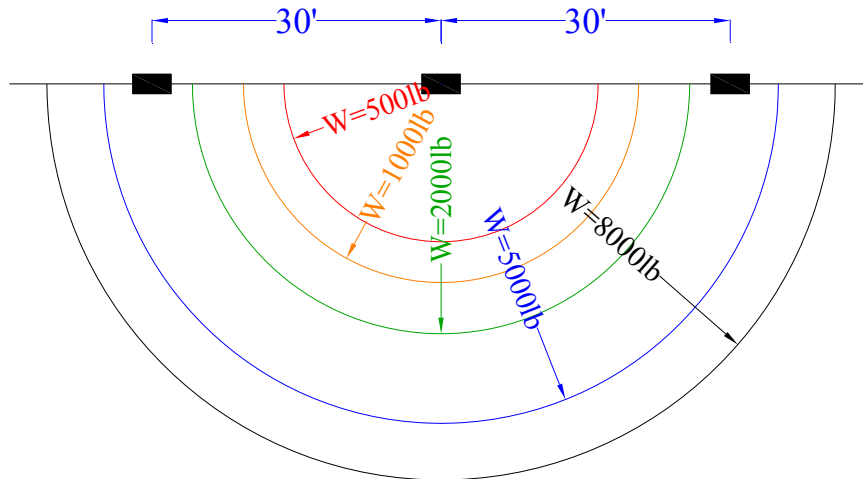

Figure 3-18: Comparison of blast load effects due to Direct Shear Failure

3.4. Combined Effects of Brisance Failure, Flexural Failure and Direct Shear Failure

By the same procedure discussed above for Brisance Failure, Flexural Failure and Direct Shear Failure, more evaluations about standoff distance and weight of charge can be determined as Table 3-3 shows:

Table 3-3: Combined blast load effects due to Three Failures

Weight of Charge (lb)	Standoff Distance (ft)		
	Brisance Failure	Flexural Failure	Direct Shear Failure
500	11.9	No	16.3
1000	15	No	20.5
2000	18.9	No	25.8
3000	21.6	No	29.5
4000	23.8	50.2	32.5
5000	25.6	56.9	35
6000	27.3	63.4	37.2
7000	28.7	69.3	39.2
8000	30	74.8	40.9
9000	31.2	80.3	42.6
10000	32.3	84.9	44.1

In order to specify the combined effects of three failure cases on one structure, taking $W=5000$ lb as an example to illustrate details about the amount of failed columns and the safe-range for Brisance Failure, Flexural Failure, and Direct Shear Failure, respectively.

3.4.1 Brisance Failure

If the charge is located in the Brisance Failure area, more than one column will be damaged instantaneously. Moreover, the number of failed columns will be increased when the explosion occurs in the common area, as discussed previously. Figure 3-19 takes one-quarter of the structure in plan view to illustrate brisance failure condition combined with flexural failure and direct shear failure. In the zigzagged area where the detonation explodes, three columns will be failed; for the lined region, two will be damaged; within the rest area of enclosed region, only one column failure will happen. Beyond the area enclosed by the red curve, columns might be damaged due to Flexural Failure or Direct Shear Failure.

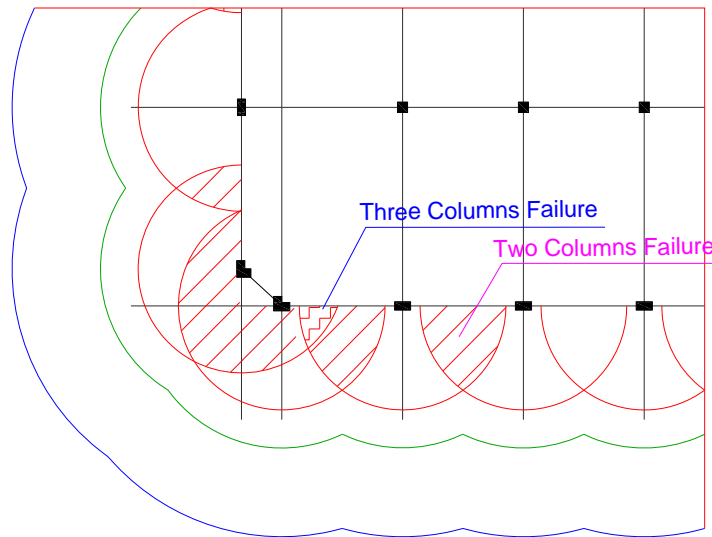

Figure 3-19: Brisance failure condition at $W=5000$ lb

3.4.2 Flexural Failure

Flexural Failure is considered in the region beyond Direct Shear Failure, as illustrated by the blue region in Figure 3-20. Four columns will be failed if the charge is located in the solid area. Additionally, three and two columns failure will happen when the detonation explodes in the zigzagged and lined areas, respectively.

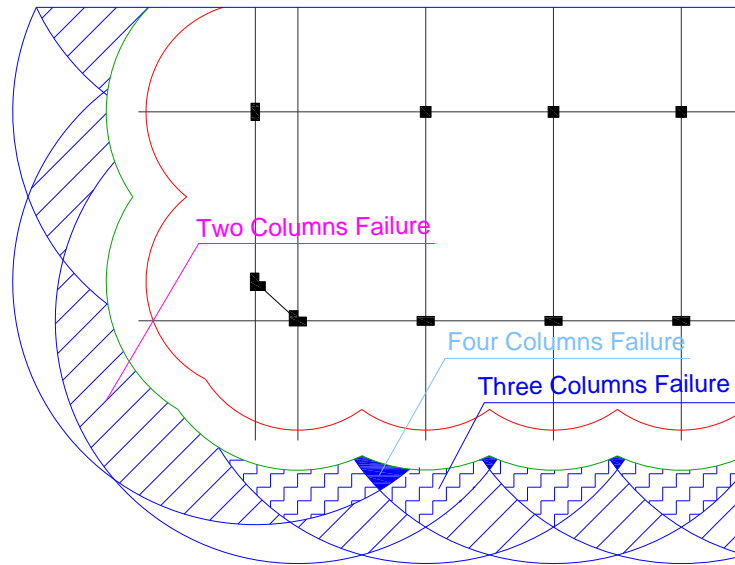

Figure 3-20: Flexural failure condition at $W=5000\text{lb}$

3.4.3 Direct Shear Failure

Direct Shear effects will be applicable only in the green region as shown in

Figure 3-21, which is beyond the common area of Brisance Failure effects but within the region of Flexural Failure effects. Different from Flexural Failure, the maximum number of columns failure is two in this case. Two columns failure happens when the charge is located in the lined region.

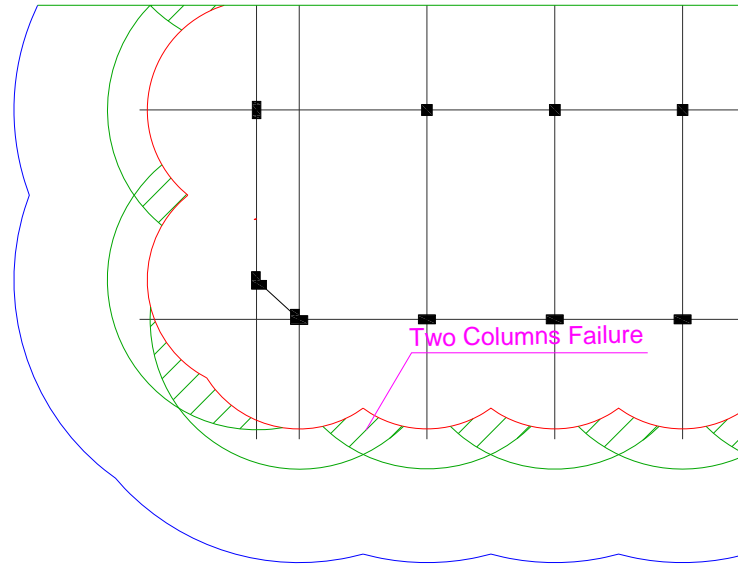

Figure 3-21: Direct shear failure condition at $W=5000\text{lb}$

3.4.4 Combined Effects of Failure Cases

The effects of brisance failure, flexural failure and direct shear failure are combined in Figure 3-22. As shown in Figure 3-22, in the red region, two columns failure due to brisance failure is the case most likely to occur. One columns failure is most likely to occur, if the charge is located in the green region of direct shear failure. Similarly, if the charge is in the blue area, two or three columns are more likely to fail due to flexural failure.

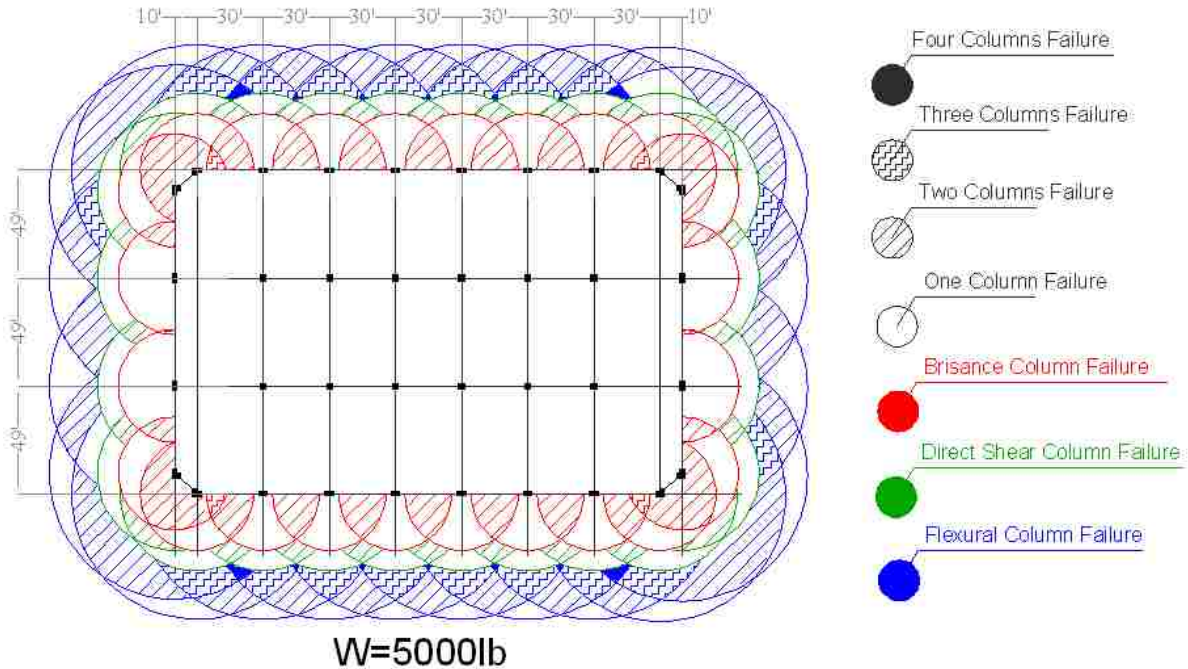

Figure 3-22: Combined effects of failure cases

3.5. Generalized Safe-range for Brisance Failure, Flexural Failure and Direct Shear Failure

Based on the separated and combined analysis for three failure cases, a generalized safe-range could be determined to provide controlling region according to each failure case. Also take $W=5000$ lb of TNT as an example, with the generalized safe-range as shown in Figure 3-23, the failure reason can be roughly but easily determined. For instance, if the charge is located and exploded in the green region, Direct Shear will control the failure, and corresponding enhancement, such as increasing the amount of transverse reinforcements, is needed to the column considered. Therefore, Structural Engineers can be able to apply different methods based on control regions to enhance the columns system conveniently and improve the abnormal load resistance of the whole structure directly. Moreover, a simplified view of generalized safe-range is summarized as an assembly of approximate rectangular

regions in Figure 3-24., the standoff distance for Brisanse Failure is 20 ft, for Flexural Failure is 55.47 ft, and for Direct Shear Failure is 32 ft.

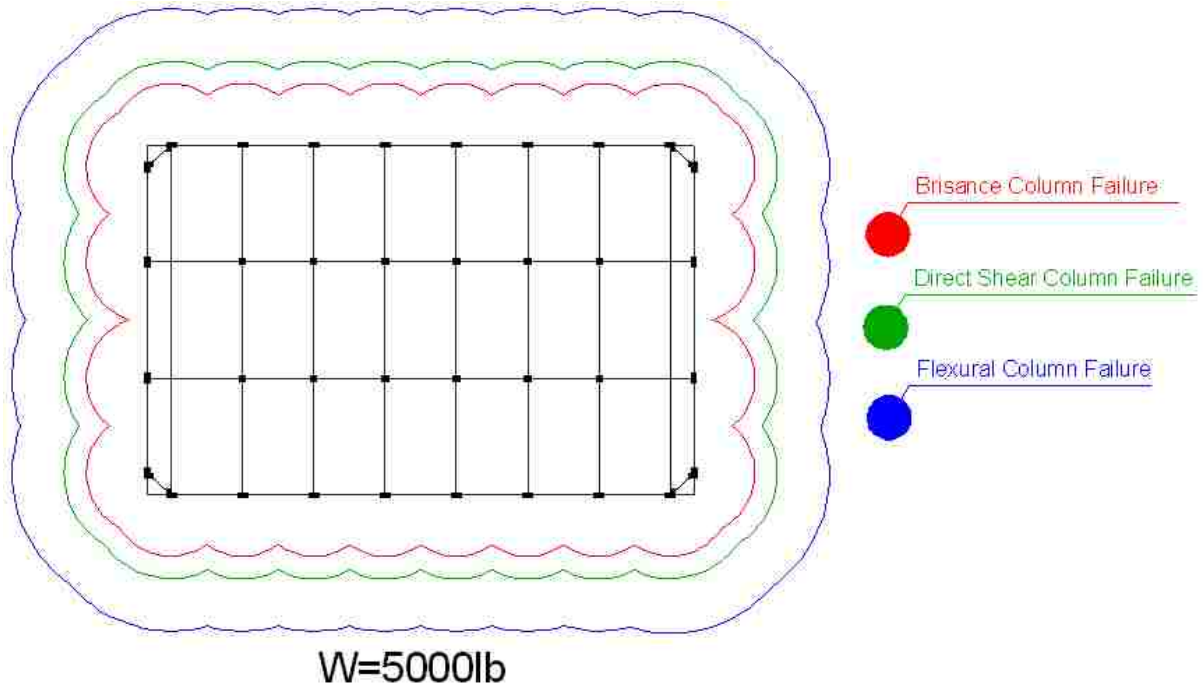

Figure 3-23: Generalized safe-range due to BF, FF, and DSF

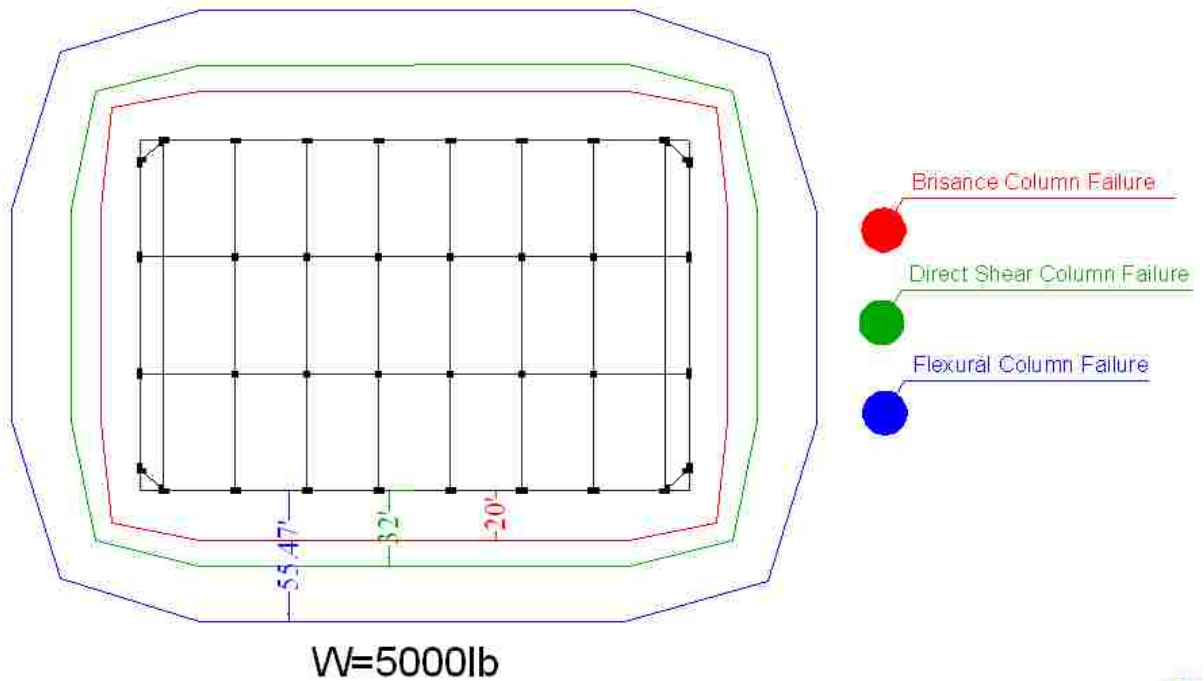

Figure 3-24: Simplified safe-range due to BF, FF, and DSF

3.6. Realistic Failure Criteria

According to the UFC and GSA criteria, only one column is removed under a progressive collapse analysis. Even though different locations of column removal are considered, the condition that more than one column might be damaged due to a blast load is not considered. As illustrated in this chapter it is highly likely that multiple columns could be lost under a blast event. Furthermore the example is focused on a precast concrete structure with widely spaced columns. For traditional reinforced concrete buildings the columns may be spaced at a closer distance and as a result the multiple column loss condition could be amplified. As illustrated multiple column loss should be considered likely and resulting progressive collapse analyses should take this into account. As an alternate the procedure shown can be used to develop minimal standoff distances needed to minimize column failure under various demands. Use of bollards and other perimeter reinforcement measures is recommended.

4. PROGRESSIVE COLLAPSE DESIGN CRITERIA AND GUIDELINES

This section provides information of four criteria about progressive collapse design, including ACI318-08(ACI318-08, 2008), ASCE7-10(ASCE7-10, 2010), GSA(GSA, Progressive Collapse Analysis and Design for New Federal Buildings and Major Modernization Projects, 2003), and UFC(UFC-4-023-03, 2010). The latter two criteria are popular used in real design. Additionally, this report is mainly about progressive collapse analysis of precast concrete structure based on GSA and UFC. Therefore, details in GSA and UFC are mainly discussed in this section.

4.1. ACI-318 Recommendation for Precast Concrete Structures

As described in ACI 318(ACI318-08, 2008), structural integrity is mainly discussing about TENSION TIES which are used in all precast concrete structures by reinforcement and connection hardware to achieve integrity of structures. For precast concrete construction, tension ties include the transverse, longitudinal, and vertical directions and around the perimeter of the structure, in order to tie elements together effectively. See details in Figure 4-1. The overall integrity of a structure can be substantially enhanced by minor changes in the amount, location, and detailing of member reinforcement and in the detailing of connection hardware, however, connection details that rely solely on friction caused by gravity forces are not permitted (ACI318-08, 2008).

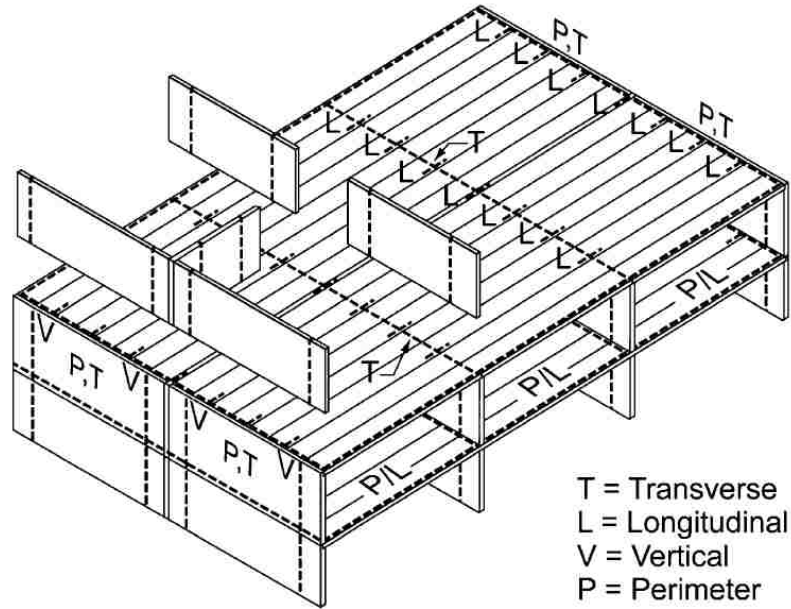

Figure 4-1: Typical arrangement of tensile ties in large panel structures (ACI318-08, 2008)

4.1.1 Design Method

For the horizontal direction, longitudinal and transverse ties are applied to connect members to a lateral load-resisting system. In the roof or floor systems of precast concrete structures, the connections between diaphragms and laterally supported members shall have a nominal tensile strength capable of resisting not less than 300 lb/ft. Individual members can be connected into a lateral load-resisting system by other methods (ACI318-08, 2008).

Vertical tension tie requirements are applied to all vertical structural members, except cladding, and shall be achieved by providing connections at horizontal joints. For precast columns, the nominal strength in tension shall be greater than $200A_g$ in lb, where A_g is the area of the cross section of the column. A reduced area A_g shall be permitted if the area of cross section is larger than required by load consideration, but not less than one-half the total area. For precast wall panels, a minimum of two ties shall be used per panel, with a nominal tensile strength not less than 10000 lb/tie. The ties shall be permitted to be anchored into an

appropriately reinforced concrete floor slab-on-ground, when no tension acts at the base by design forces (ACI318-08, 2008).

4.2. ASCE 7 2010

ASCE (ASCE7-10, 2010) directs attention to the problem of local collapse, presents guidelines for handling it that will aid the design engineer, and promotes consistency of treatment in all types of structures and in all construction materials. Generally, connections between structural components should be ductile and have a capacity for relatively large deformation and energy absorption under the effect of abnormal conditions. ASCE 7-10 provides a number of conceptual ways of designing for the required integrity, such as good plan layout, returns on wall, ductile detailing and so forth. For example, in bearing-wall structures there should be an arrangement of interior longitudinal walls to support and reduce the span of long sections of cross wall, thus enhancing the stability of individual walls and of the structures as a whole. In the case of local failure, this will also decrease the length of wall likely to be affected. In consideration of ductile detailing, avoid low-ductility detailing in elements that might be subject to dynamic loads or very large distortions during localized failures. For a detailed background a review of the base document ASCE7-10 is recommended. The document is listed as open distribution and is available.

4.3. UFC

UFC (UFC-4-023-03, 2010) Design of Buildings to Resist Progressive Collapse is applied in this report. The UFC method is applied to both new and existing buildings . The design approach is dependent on the use or occupancy of the building structure. Based on the level of occupancy three design approaches are used. They include the tie force (TF), enhanced local resistance (ELR), and alternate load path (AP) method. For high levels of occupancy

and criticality all three methods may be required while for low levels of criticality none of the methods may be needed. An overview of the specifics of the approach and the methodologies are presented in this section. For a detailed background a review of the base document UFC 4-023-03 is recommended. The document is listed as open distribution and is available.

4.3.1 Determination of Occupancy Category (OC) and Design Method

The level of progressive collapse design required is based on expected occupancy category (OC) of the structure. The OC level is divided into 4 levels with each level having increasing consequences if a progressive collapse event was to occur. The OC level is based on two main factors: level of occupancy and building function or criticality as outlined in Table 4-1.

The design methods required are based on the occupancy category as summarized in Table 4-1. An outline of each method follows.

Table 4-1: UFC occupancy and design requirements

Occupancy Category	Nature of Occupancy	Design Requirements		
		TF	ELR	AP
I	Low occupancy ; Low hazard to human life in the event of failure	No Specific Requirements		
II	Inhabited buildings with less than 50 personnel, primary gathering buildings, billeting, and high occupancy family housing; Buildings and other structures except those listed in Categories I, III, and IV.	Option 1: TF and ELR or Option 2: AP See UFC for details.		
III	Buildings and other structures that represent a substantial hazard to human life or represent significant economic loss in the event of failure.		√	√
IV	Buildings and other structures designed as essential facilities; Facilities designed as national strategic military assets	√	√	√

4.3.2 Design Methods

4.3.2.1 Tie Force Method

The tie force method is considered as an indirect method to enhance the entire structure in order to resist progressive collapse. The tie force method requires that the tensile force capacity of the floor or roof system be adequate to allow the transfer of load from a damaged portion of the structure to an undamaged portion. The approach does not specifically remove any vertical elements but instead requires a minimum horizontal tensile strength in the floor or roof diaphragm. The required tensile strength F_t is equated to the factored applied vertical dead and live loads, WF . For a uniform floor load a 1.2 dead load factor and 0.5 live load factor is used for computation of WF . For non-uniform or point loads alternate procedures are proposed.

According to UFC, three types of horizontal ties are required to provide integrity to the floor and roof diaphragms. They include longitudinal, transverse and peripheral ties, which are the same as ACI318-08. The longitudinal and transverse ties are equal to 3 times the tributary distributed load. The peripheral ties are equated to 6 times the tributary distributed vertical load.

Vertical ties are required in columns and load-bearing walls across each floor level. These elements must be tied. For these elements the highest vertical force must be transferred in tension. Figure 4-2 shows a 3-D view of ties in a frame structure.

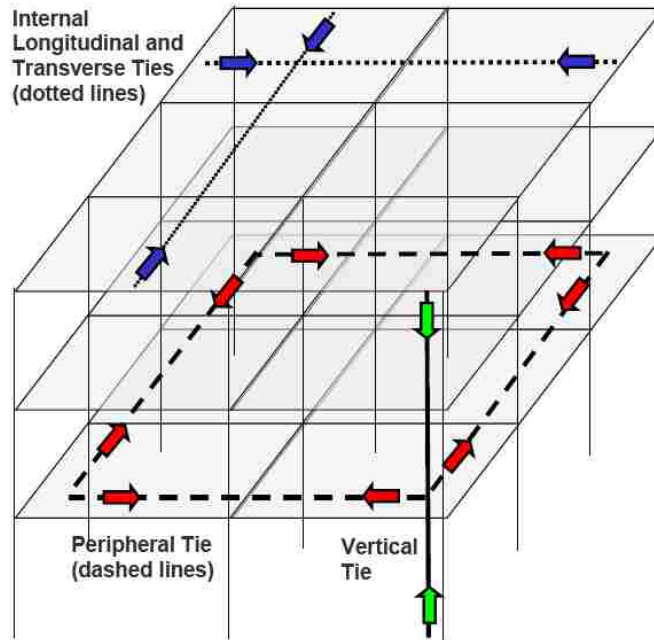

Figure 4-2: Tie forces in a frame structure (UFC4-023-03, 2010)

4.3.2.2 Alternate Path Method

Under this approach the building must bridge across a removed element, so it is a direct method for progressive collapse analysis and design. Especially, if a corner column is specified as the removed element location in a ten story building with a column splice at the third story, one AP analysis is performed for removal of the ground story corner column; another AP analysis is performed for the removal of the corner column at the tenth story; another AP analysis is performed for the fifth story corner column (mid-height story) and one AP analysis is performed for the fourth story corner column (story above the column splice). Figure 4-3 provides a plan view of locations of external removed columns for framed structures.

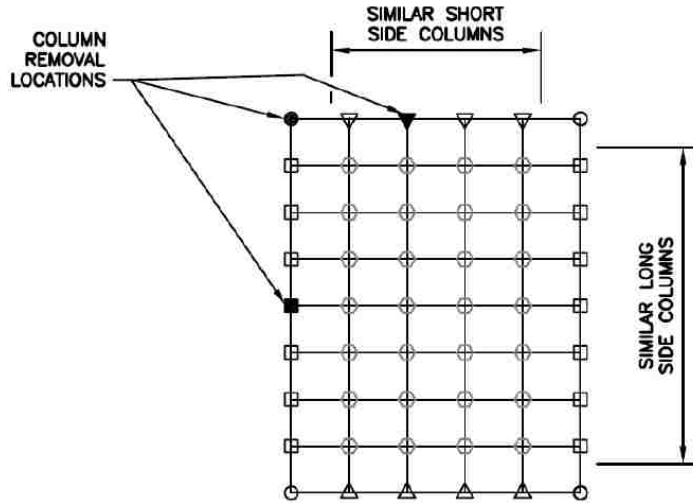

Figure 4-3: Plan view of removed column location (UFC4-023-03, 2010)

For this method, analysis conditions are grouped as deformation controlled action and force controlled action. In calculation of moment, vertical loads should be evaluated with increased factor for deformation-controlled action in the specific area. In consideration of shear force, load increase factor for force-controlled action should be used. Figure 4-4 and Figure 4-5 show the loads and load locations of linear and nonlinear static models in plan view and elevation view, respectively.

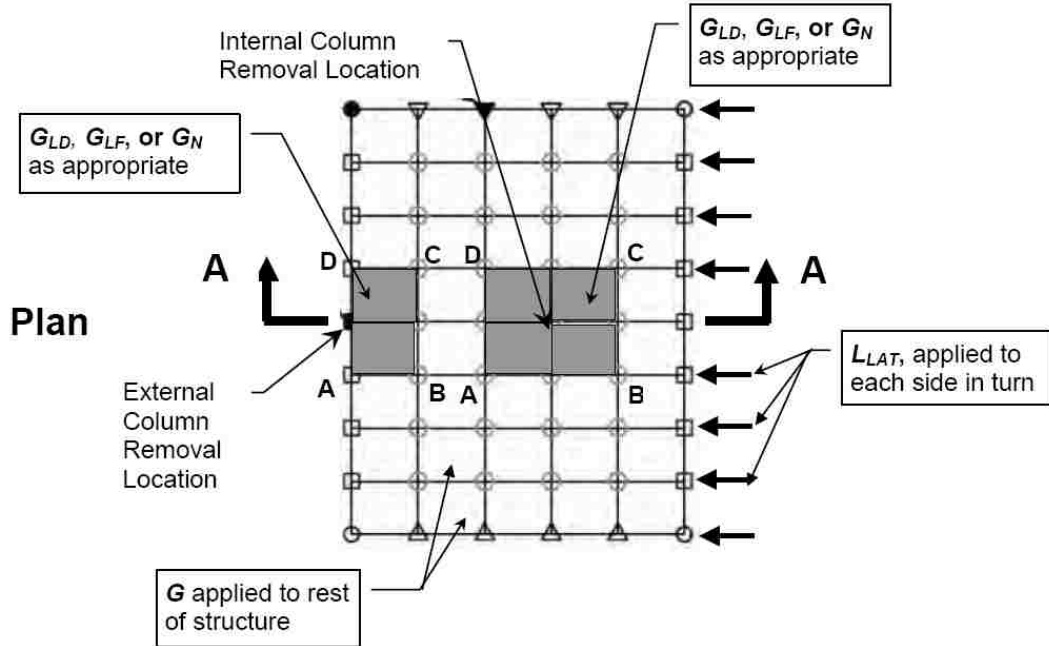

Figure 4-4: Plan view of loads and load locations of linear and nonlinear static models(UFC4-023-03, 2010)

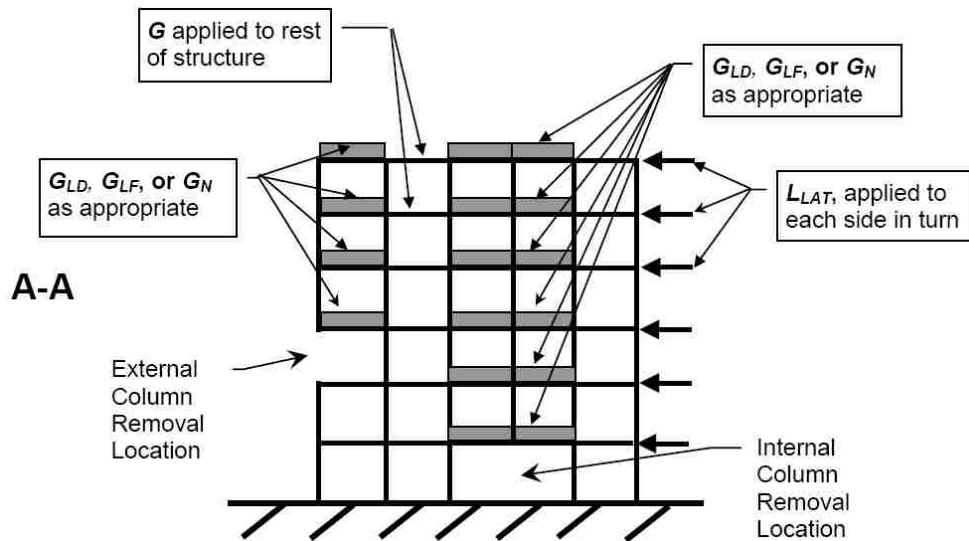

Figure 4-5: Elevation view of loads and load locations of linear and nonlinear static models (UFC4-023-03, 2010)

Three analysis procedures are employed in AP method: Linear Static (LSP), Nonlinear Static (NSP) and Nonlinear Dynamic (NDP).

Linear Static Procedure (LSP) is applied for regular structures or irregular structures with $DCR \leq 2.0$, where DCR is the value of demand-capacity ratio. The model of LSP includes all the primary components except the removed component, yet, it is optional to include secondary components in modeling. When modeling the building by LSP procedure, the column considered to be failed shall be removed preceding the factored load applied on the considered region of the structure. In comparison with GSA method, linear static procedure in UFC requires to apply m-factored load only over the areas above the removed column directly, while for GSA the increased factored load, which is equal to 2 times dead load plus 0.5 times live load, shall be applied at each floor level over the whole structure.

Nonlinear Static Procedure (NSP) and Nonlinear Dynamic Procedure (NDP) have no limitations of structural regularity in applications, and reduction factors shall be applied to the strength models of the deformation-controlled action. For nonlinear procedures, the ductility or ends rotation shall be calculated and designed within limits for in deformation controlled actions, such as moment and axial force. However, in force controlled action, for example the shear force, shall be limited within the strength capacity. NSP is modeling similar as LSP without the removed component; however, all the components shall be included in structural modeling for NDP.

4.3.2.3 Enhanced Local Resistance

ELR is provided through the flexural and shear resistance of perimeter building columns and walls, in order that the shear resistance of the column, load-bearing wall, and their connections must be greater than or equal to the shear capacity associated with the baseline flexure (for OC II option 1 and OC III), or the enhanced flexure (for OC IV). The approach

does not specifically remove any vertical elements but instead requires enough flexural and shear resistance in the column of wall system.

Flexural resistance is the magnitude of the uniform load acting over the height of the wall or load-bearing column which causes flexural failure. For OC II option 1, baseline flexural resistance is depending on definition of flexural resistance, but for OC III, it should meet the requirement of AP method first. In the condition of OC IV, enhanced flexural resistance is applied, which is the larger value of existing flexural resistance and factored baseline flexural resistance.

4.3.3 Use of Design Methods for Precast Structures

“For precast concrete floor and roof systems, the rebar within the precast planks may be used to provide the internal tie forces, providing the rebar is continuous across the structure and properly anchored; thus may be difficult to accomplish in the short direction of plank. Also, the rebar may be placed within a concrete topping; in this case, provide positive mechanical engagement between the reinforcement and the precast floor system, with sufficient strength to insure that the precast units do not separate from topping and fall to the space below. It is not permitted to rely on the bond strength between the topping and precast units, as bond can be distributed by the large deformations associated with catenary behavior. This attachment between the rebar in the concrete topping and precast planks may be accomplished with hooks, loops or other mechanic attachments that are embedded in the precast floor units.”(UFC-4-023-03, 2010)

4.4. GSA

The GSA guidelines are used for design of Federal Facilities, specifically for the design of new facilities, the assessment of existing facilities, and development of upgrades where needed. Exemption is allowed for facilities with extremely low occupancy and extremely low likelihood for progressive collapse (GSA, Progressive Collapse Analysis and Design for New Federal Buildings and Major Modernization Projects, 2003). An exemption evaluation process is provided. If the facility is not exemption from further consideration of progressive collapse,

linear procedure and nonlinear procedure are used. The approach specifically removes one vertical element in the considered location and level in exterior or interior sections for each analysis. Generally, GSA provides a method to determine the potential of progressive collapse, and the collapsed condition can also be simulated by GSA. For the purpose of progressive collapse resistance, the components of even the structures shall be redesigned if the structure is determined as high potential of progressive collapse. An overview of the specifics of the approach and the methodologies are presented in this section. For a detailed background a review of the base document GSA is recommended. The document is listed as open distribution and is available.

4.4.1 Exemption Process

Exemption Process is offered for both new and existing construction, to identify whether or not further progressive collapse consideration are required based on building occupancy, category, number of stories, detailed description of local and significant global structural attributes. In combination with minimum defended standoff distance consistent with the construction type and required level of protection (Table 3.1 from GSA), exemption is determined by flowcharts from Fig 3.1 to Fig 3.6 in GSA. If the structure had high potential progressive collapse, further consideration and design were provided.

4.4.2 Design Methods

According to GSA, all newly constructed facilities shall be designed with the intent of reducing the potential for progressive collapse, regardless of the required level of protection. Four characteristics (redundancy, structural continuity and ductility, resisting load reversal and shear failure) in initial phases of structural design are recommended to be considered. The incorporation of these features will provide for a much more robust structure and

increase the probability of achieving a low potential for progressive collapse when performing the analysis procedure in analysis.

4.4.2.1 Linear Static Procedure

Linear Static Procedure (LSP) is a simplified analysis approach, and implies the use of a static linear-elastic finite element analysis. This approach removes a vertical support component in considered location, and applies the vertical load factored by 2 for dead load and 0.5 for live load at each floor level. Similarly as UFC criteria, for framed structure with external column removal, the removed column locations are at or near the middle of the short side and long side of the building, besides the corner, as shown in Figure 4-6.

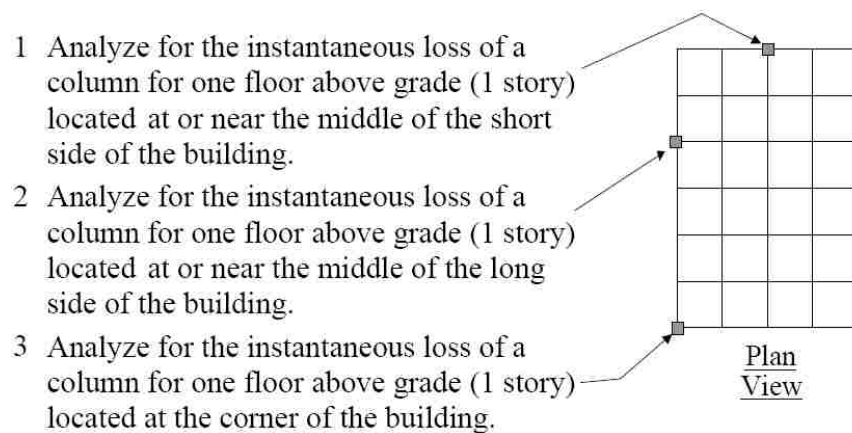

Figure 4-6: Plan view of external removed column locations of framed structure in GSA

(GSA, Progressive Collapse Analysis and Design Guidelines, 2003)

Demand-Capacity Ratios (DCR) is used as acceptance criteria. The applicable DCR value for a typical structure is no greater than 2.0, but for atypical structure is 1.5. With the instantaneous removal of a primary vertical component, the failed columns or walls based on shear force or three-hinge formation shall be removed from the model. A hinge is placed at the member end or connection to release the moment, and apply equal-but-opposite moments,

when the DCR exceeds the applicable value. All the analysis shall be re-run and the process shall be continued until no DCR values are exceeded.

If moments have been re-distributed throughout the entire structure and DCR values are still exceeded in areas outside of the allowable collapse region, the structures will be considered to have a high potential for progressive collapse and shall be redesigned to a level that is consistent with a low potential for progressive collapse

4.4.2.2 Nonlinear Static Procedure

Nonlinear Static Procedure (NSP) is applied in buildings with over 10 stories. Different from linear static procedure, ductility and ends rotation shall be calculated and checked if exceeding the limitation, the exceeding ductility and ends rotation result in removal of the components. Nonlinear static procedure (NSP) is an iteration method as well.

4.5. Summary of Comparisons of Details in GSA and UFC

Generally, GSA and UFC provide guidelines for engineers to design structures resisting progressive collapse. The main function of the GSA Guidelines is to assist in the assessment of the risk of progressive collapse in new and existing Federal Office Buildings. The GSA Guidelines consider three analysis methods: linear elastic static analysis, linear elastic dynamic analysis, and nonlinear dynamic analysis. But the GSA guideline limits the applicability of linear elastic static analysis procedures to buildings with 10 above-ground stories. The GSA guideline allows certain structures to be exempted from progressive collapse analysis on the basis of their occupancy and functional use. The guidelines include a comprehensive flow chart for determining whether a building is exempt. For linear elastic static analysis of a structure, GSA (GSA, Progressive Collapse Analysis and Design for New Federal Buildings and Major Modernization Projects, 2003) mandates the loading conditions

as $\text{Load} = 2 \times \text{Dead Load} + 0.5 \times \text{Live Load}$ in the downward direction, which is applied at each level above the removed element over the whole structure.

The main objective of UFC is to provide guidelines for minimizing casualties from terrorist attacks against DoD facilities. Determining the likelihood of progressive collapse requires performing iterative analysis for linear elastic methods. The iterative analysis method entails removing the elements if their ultimate capacities are exceeded and replacing them with fixed moments equal to their corresponding ultimate moment capacities, then reanalyzing the remaining structure. If the supporting member is determined to fail, its dynamic impact and load redistributions should also be considered. The likelihood of progressive collapse is demonstrated by showing excessive failed structural elements. Different from GSA criteria, the load conditions applied in UFC are based on deformation-controlled action and force-controlled action respectively. Additionally, the increased gravity load combination is applied to those bays immediately adjacent to the removed element and at all floors above the removed element. The detailed load conditions mandated by UFC are included in the following section.

4.5.1 Comparison of Procedures in Alternate Path Method in UFC

Linear static procedure is a simplified method which calculates and performs quickly. However, dynamic effects and material nonlinearity are not considered in linear static procedure. Similarly, nonlinear static procedure includes the nonlinear properties of material without consideration of dynamic effects. Thus, both of them are conservative methods. In general, the most realistic procedure is nonlinear dynamic method, which includes material nonlinearity and dynamic effects. But the disadvantage of nonlinear dynamic procedure is also obvious; it could be very time consuming, high complexity and hard to evaluate the

results. The table below provides details in comparison about linear static procedure, nonlinear static procedure and nonlinear dynamic procedure in UFC.

4.5.2 Comparison of Procedures in UFC and GSA

Both of UFC and GSA criteria provide guideline to design structures in resisting progressive collapse by linear and nonlinear, static and dynamic procedures. Components shall be redesigned or enhanced if the expected capacities are exceeded. Table 4-2 provides a general procedure in analyzing progressive collapse from UFC and GSA.

Table 4-2: Comparison of procedures of progressive collapse analysis and design in GSA and

UFC

	UFC	GSA
1st Step	Determination of OC level: If OC1, then no specific requirements, If other OC levels, need to meet design requirements	Determination of exemption: If it is exemption, no further consideration of progressive collapse, If not exemption, go to further consideration
2nd Step	Three methods for analysis of progressive collapse: <i>Tie Forces</i> (no removal of columns and walls), <i>Alternate Path Method</i> (removal columns and walls in considered location), <i>Enhanced Local Resistance</i> (no removal of columns and walls)	Linear static method and nonlinear static method are applied in progressive collapse analysis in GSA, they are iterating analysis until no DCR of components are exceeded the applicable flexural DCR values

4.5.3 Comparison of Alternate Path Method in UFC and GSA

Column removal is considered in AP method of UFC and GSA, so both methods can be considered as direct methods. For alternate path method in UFC, the components needed to be redesigned or enhanced are determined directly without any other elements removal. However, the methods in GSA are iteration procedures, by which the failed components are

removed and collapse situation can be simulated. More detailed comparisons are included in Table 4-3.

Table 4-3: Comparison of Alternate Path method in UFC and GSA

	Alternate Path method in UFC	GSA
Removal	Remove one column/wall only in considered locations: *Corner section *Mid-span columns or walls in longitudinal and transverse direction	Remove one column/wall in the similar considered locations as UFC. The components shall be removed if they were considered as failure during iteration of linear static analysis or nonlinear static analysis, as following described: *Ends or connections, DCR exceeds by shear *Three hinge formations
Components in consideration	Primary Components, inclusion secondary components is optional, but need to check	All the components without removed columns and walls.
Load	Determined by deformation-controlled action and force-controlled action and locations	For Linear Static Analysis: $L=2(DL+0.25LL)$ For Linear Dynamic Analysis: $L=DL+0.5LL$
Main Procedure	According to load and location of removed components, calculate required strength Note: *For internal columns and load-bearing walls of each plan location, the AP method analysis is only performed for the story with the parking or uncontrolled public area; * For external columns and load-bearing walls of each plan location, perform analysis for: a)First story above grade b)Story directly below roof c)Story at mid-height d)Story above the location of a change in column or wall size.	1. According to load and removal of components, calculate DCR of all members. 2. Determine if DCR exceeds the applicable value(for typical structure, $DCR \leq 2.0$, for atypical structure, $DCR \leq 1.5$) 3. For a member of connection whose DCR exceeds the applicable flexural values, place a hinge at the member end or connection to release the moment, and apply equal-but-opposite moments. 4. Re-run the analysis and repeat Step1 through3. Continue this process until no DCR values are exceeded.
Check	Design strength \geq Required Strength (based on each procedure)	If moments have been re-distributed throughout the entire structure and DCR values are still exceeded in areas outside of the allowable collapse region, the structures will be considered to have a high potential for progressive collapse. The structure shall be redesigned to a level that is consistent with a low potential for progressive collapse

5. PROGRESSIVE COLLAPSE MODELING OF PRECAST STRUCTURE

In this report, the moment frame building system demonstrated in Chapter 2 is used to simulate progressive collapse. Based on the information about the building system, three modeling cases are introduced in this section, including original model, modified model with continuous double-length cantilever beam, and modified model with continuous double-length fixed-fixed end beam. The progressive collapse analyses of the three cases are preceded by Linear Static Analysis (LSP) based on UFC and GSA. The analysis is carried out by using computer program ETABS Nonlinear V9.7.1. Comparison of results and the corresponding modifications in each model is made and detailed analyses about deflections in the later two cases are presented in the following sections.

5.1. Introduction of Three Model Cases

5.1.1 Column Removal

Based on the effects of blast load applied on the building system, the columns located near the middle of the long side are in higher potential of failure than other columns. Additionally, UFC and GSA require that the analysis shall be considered with the instantaneous loss of one column above grade located at or near the middle of long side of the building. Although UFC criterion includes the considerations of columns removal in other floors, only one column is removed instantly when doing analysis of progressive collapse for both UFC and GSA. According to the previous analysis about blast load effects on vertical supporting elements, column failure of Story-1 is only considered in this report. Figure 5-1 shows the 3-D model simulated in ETABS. Figure 5-2 provides an image of plan view of Story-8 simulated in ETABS. The column of Story-1 along Line D-5 is removed in this case, as shown in Figure 5-3.



Figure 5-1: 3-D extruded view of the model simulated in ETABS

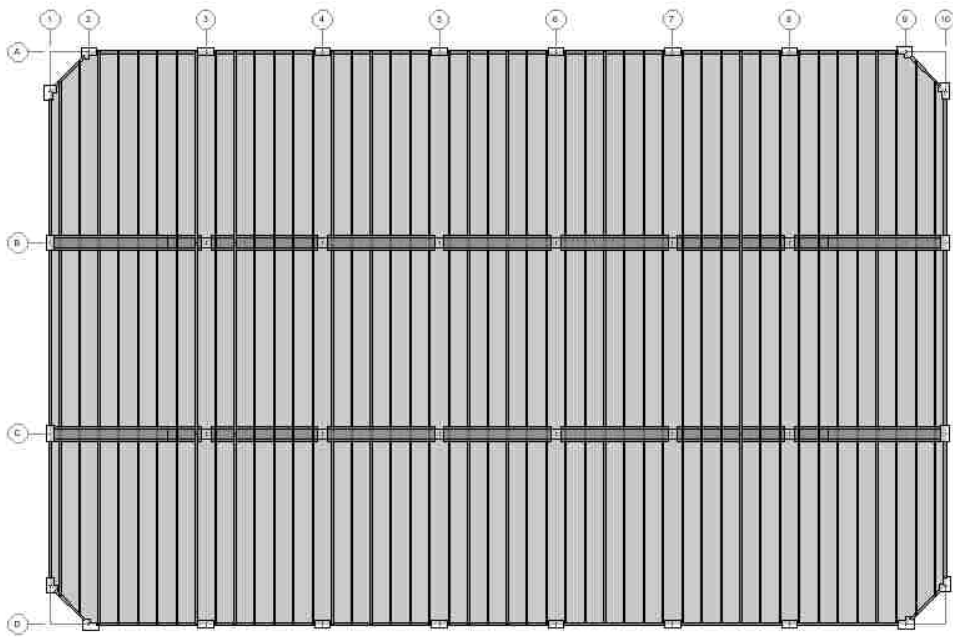

Figure 5-2: Extruded plan view of the model simulated in ETABS

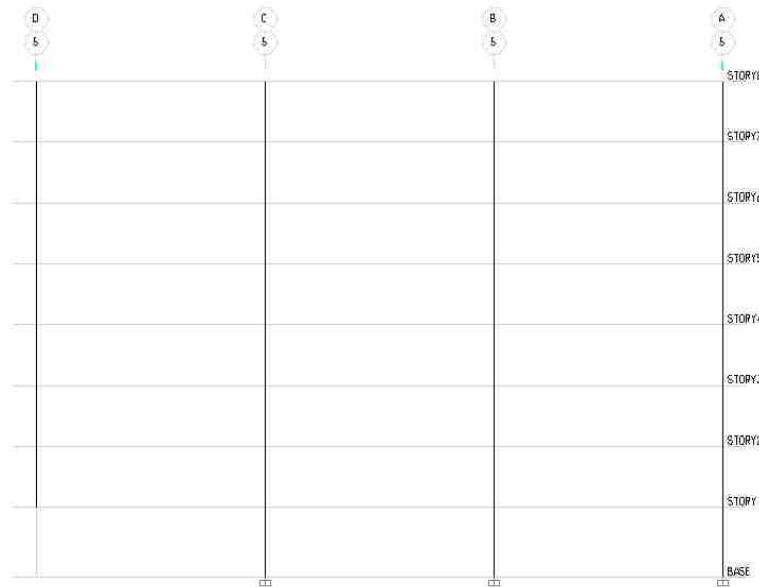

Figure 5-3: Removed column location in Elevation-5 view of the model simulated in ETABS
5.1.2 Exterior Section

The 9 in-wide and 96 in-deep spandrel beams in exterior sections are connected by steel plates based on Seismic Design Category B (SDC B). The steel plates are 0.75 in thick and 8 in deep with $f_y = 36\text{ksi}$ and $f_u = 58\text{ksi}$, which are providing the maximum tensile resistance of 216 kip and ultimate tensile resistance of 348 kip. The spacing between two plates is 6 ft, so the expected moment capacity provided by the plates is 1296 kip-ft and the ultimate moment capacity is 2088 kip-ft. For this connection model, only the flexural capacity is considered, namely, the failure due to inadequate shear capacity is ignored. In linear static analysis, the connection is simulated as rigid. Reinforcement details are illustrated in Figure 5-4.

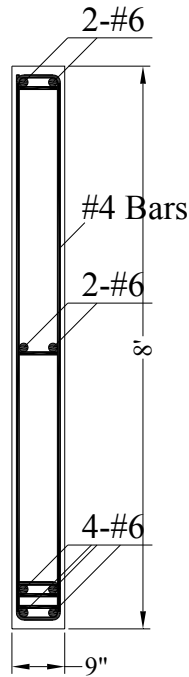

Figure 5-4: Spandrel Beam Cross Section

The length of the single spandrel beam in exterior section is 30 ft with the depth of 8 ft. The column width is 4 ft, the clear length of the beams is 26 ft. According to ACI-318 section 11.7.1, the members with clear length not exceeding four times the overall member depth should be treated as deep beams. Thus, the spandrel beams considered belong to deep beams. Based on ACI-318 section 11.7.4, the area of shear reinforcement perpendicular to the flexural tension reinforcement, A_V , shall not be less than $0.0025 \times b_w \times S$, and S shall not exceed the smaller of $d/5$ and 12 in, where b_w is the beam width, S is center-to-center spacing of transverse reinforcements, d is distance from extreme compression fiber to centroid of longitudinal tension reinforcement. As a result, placing #4 bars with 2 legs at every 12 in satisfies the above requirement, which provides 186 kip shear resistance by equation $V_S = \frac{A_V \times f_{yt} \times d}{S}$, where $f_{yt} = 60$ ksi. Approximately, the shear strength provided by concrete is evaluated by equation $V_C = 2 \times \sqrt{f'_C} \times b_w \times d_p = 130$ kip, where $f'_C = 6$ ksi,

$b_w = 9\text{in}$, and $d_p = 93\text{in}$. Consequently, the spandrel beams with minimum transverse bars provide a shear resistance of 316 kip. The equations utilized are from ACI318 (ACI318-08, 2008).

5.1.3 Interior Section

The beam-column connection in the interior section is rigidly connected. The dimension of inverted tee beam and reinforcements are the same from Story-1 to Story-3. 7-#10 bars are placed at the top of the inverted tee beam for negative moment resistance, and 6-#8 bars are located at the bottom to resist positive moment. The remaining reinforcements in the cross section are #5 bars. Thus, the expected moment capacity at the critical section of the connection is 2171 kip-ft. Similarly, 7-#10 bars and 6-#8 bars are placed at the top and the bottom in the inverted tee beams from Story-4 to Story-8, respectively. The remaining reinforcements in the corner sections are all #5 bars. Even the depth of the beam cross section of story4-8 decreased to 36 in, the connection can provide 1877 kip-ft as expected moment capacity in local-3 direction and 1972 kip-ft in local-2 direction. The shear resistances at the critical sections of beams are 577 kip and 492 kip for story1-3 and story4-8, respectively. The inverted tee beams corresponding to different levels simulated in ETABS are illustrated in Figure 5-5 and Figure 5-6.

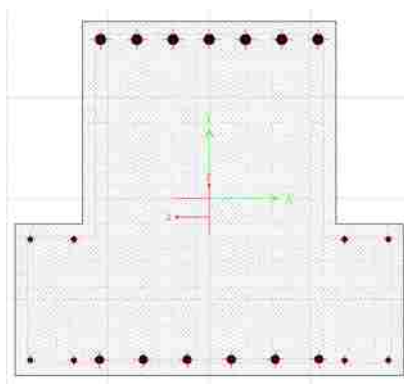

Figure 5-5: Interior Section Inverted Tee Beam Story1-3 simulated in ETABS

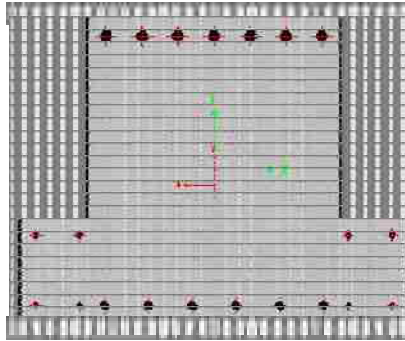

Figure 5-6: Interior section Inverted Tee Beam Story4-8 simulated in ETABS

The detailed moment and shear capacity of each element are summarized in Table 5-1.

Table 5-1: Moment and Shear Capacity Details in Connections (un-factored)

Section	Frame Elements		Moment (kip-ft)		Shear (kip)
			Positive	Negative	
External Section	Spandrel Beam	Steel Plates	2088	2088	Adequate
		Beams	1528	943	316
Internal Section	Inverted Tee Beam in story1-3	Local-3	2171	2787	577
		Local-2	2281	2281	577
	Inverted Tee Beam in story4-8	Local-3	1877	2320	492
		Local-2	1972	1972	492

5.2. Analysis Package

ETABS Nonlinear V9.7.1 is applied in modeling and analyzing by linear static procedure in this report.

5.2.1 System Model

According to the building structure in PCI Seismic Analysis and Design for Precast/Prestressed Concrete Structures, the roof and floor system consist of double tee slabs, and the cross section details are presented in Figure 5-7. The double tee slabs are simply supported on the inverted tee beams. In this building model, the ribs of the double tee slabs

are simulated as secondary deep beams in rectangular cross section with the average width of 4.75 in and the depth of 22 in. Since the topping above slabs is 3.5 in, the depth of the upper section of the double tee slabs combined with the topping above the ribs is equal to 5.5 in. The un-factored dead load applied on the floor and roof system is 111 psf and the reduced live load with a reductive factor of 0.4 is 24 psf. These vertical loads are applied uniformly. The load case combinations of progressive collapse analysis are based on GSA and UFC individually and the corresponding acceptance criteria are different.

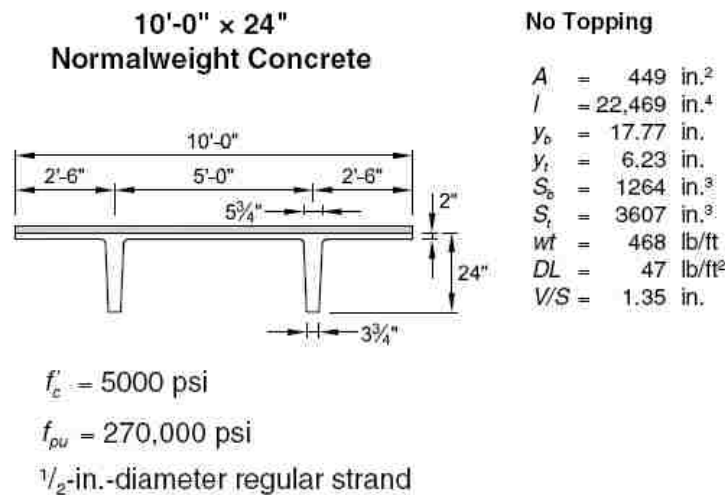

Figure 5-7: Properties of double tee slab(PCI, 2010)

5.2.2 Case1: Original Model

In this case, beam-to-beam connections and beam-to-column connections in the exterior section are simulated as the original model under Seismic Design Category B (SDC B). Since the single spandrel beams are connected to the column by steel plates, the expected moment resistance of 1296 kip-ft and the ultimate moment resistance of 2088 kip-ft are generated. The spandrel beams are modeled as rigidly connected due to the moment generation. Assume the steel plates have adequate shear capacity to resist shear failure, so only the flexural capacity is considered. This assumption also satisfies the requirement of “strong shear, weak

bending”. However, as prescribed in PCI Seismic Analysis and Design for Precast/Prestressed Concrete Structures, a typical design for the spandrel beams as simply supported includes four $\frac{1}{2}$ in. strands near the bottom and two $\frac{1}{2}$ in. strands near mid-height for handling and crack control. The anchorage bars for the connection assembly are 3-#9 bars to be sufficient to develop the connection force. These bars are projecting into the length of the beam sufficient for development as a Class B splice. 3-#9 bars with end hooks are placed to match the tail bars from the connection assembly. Figure 5-8 and Figure 5-9 illustrate the global elevation view and local elevation view about column removal.

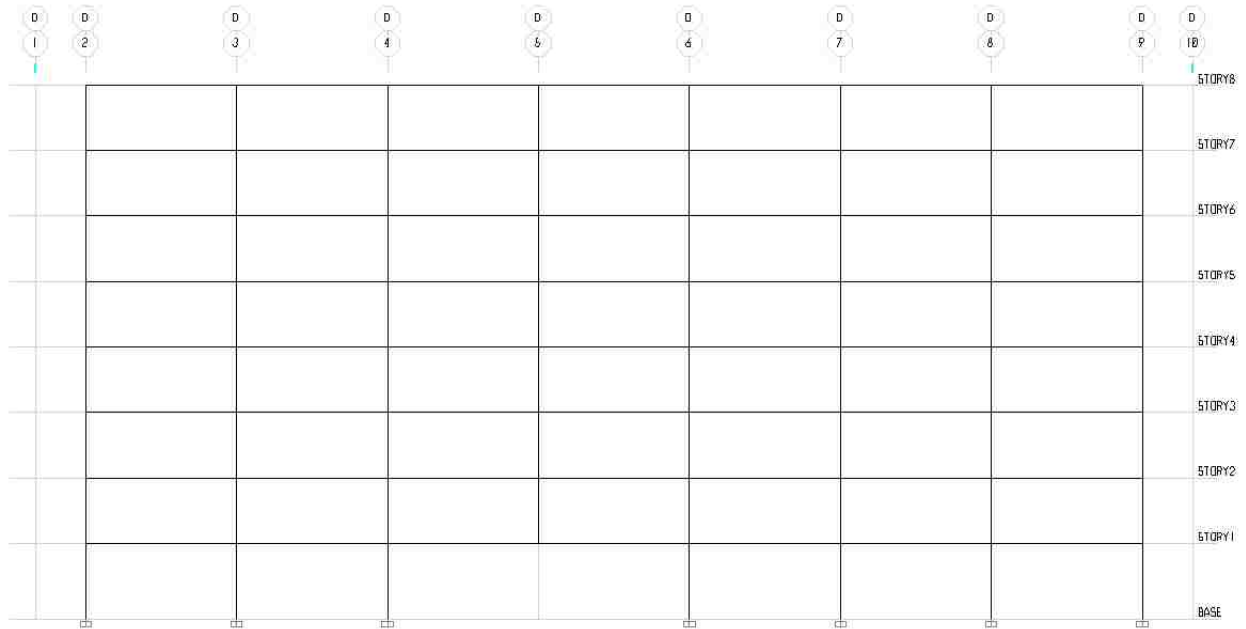

Figure 5-8: Elevation-D of model of Case 1 in ETABS

The detailed local beam-to-column connection is indicated in Figure 5-9.

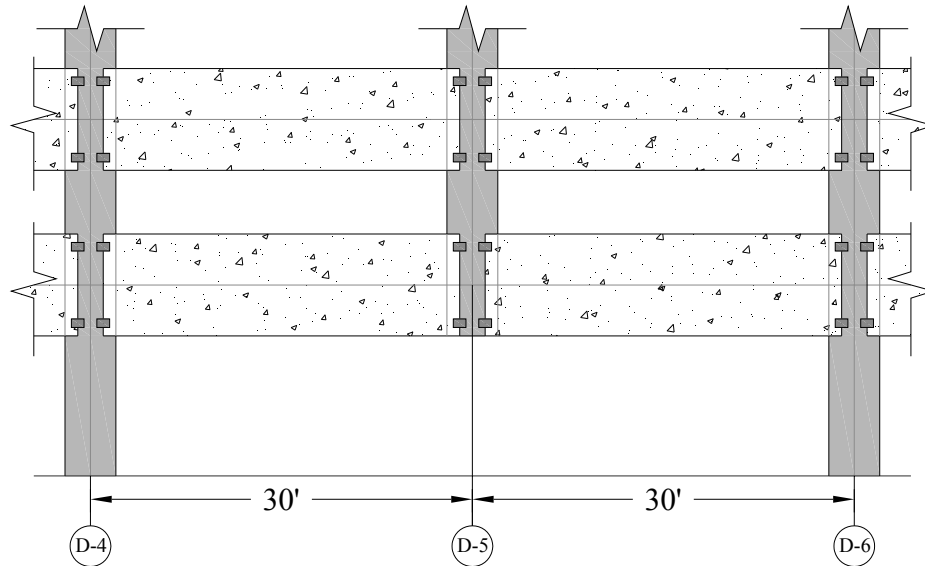

Figure 5-9: Local Elevation-D of Case 1

5.2.3 Case2: Modified Model with Cantilever Beam

For Case 2, two double-length continuous spandrel beams are placed at Story-1 instead of the original single beams.

Similarly as Case 1, the beam-to-column connections are modeled as rigid, except the connection at Line D-5 of Story-1. At Line D-5, the continuous beams of Story-1 are connected to the columns by steel plates as partially fixed; the flexural stiffness is based on the steel plate's moment-rotation relationship. However, the columns above and below the spandrel beams in Line D-4 and Line D-6 are modeled as pinned connected to those beams at Story-1. As expected, the moment of the spandrel beam at the pinned connection develops continuously, which acts like a cantilever beam with fixed end to support the gravity load. Even though the loss of columns' moment resistance at connections results in moment increasing in the spandrel beams, it is more reliable to provide moment resistance by reinforcements in spandrel beams instead of steel plates, since the effectiveness of moment resistance might be affected by the anchorage bars (discuss later). Meanwhile, the portion of

the continuous beam between line D-3 and line D-4 plays a more important role to resist the vertical load acted at the end because of moment continuity. This situation is also applicable for the other continuous beams. Simulation of Elevation-D of Case 2 in ETABS is as shown in Figure 5-10, and the corresponding local condition is illustrated in

Figure 5-11.

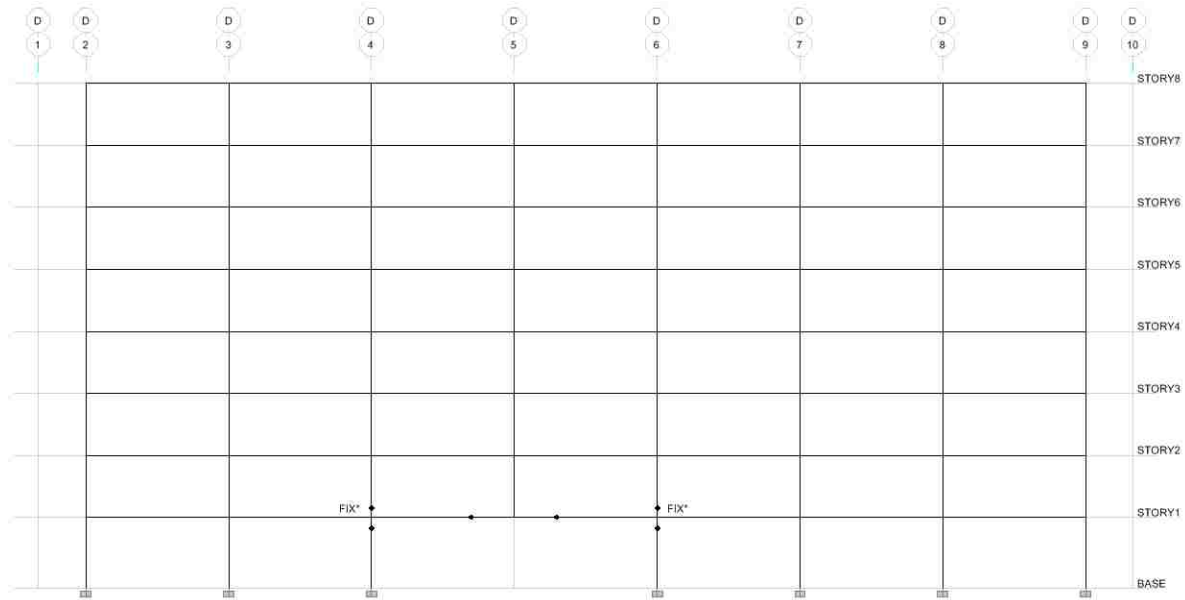

Figure 5-10: Elevation-D of model of Case 2 in ETABS

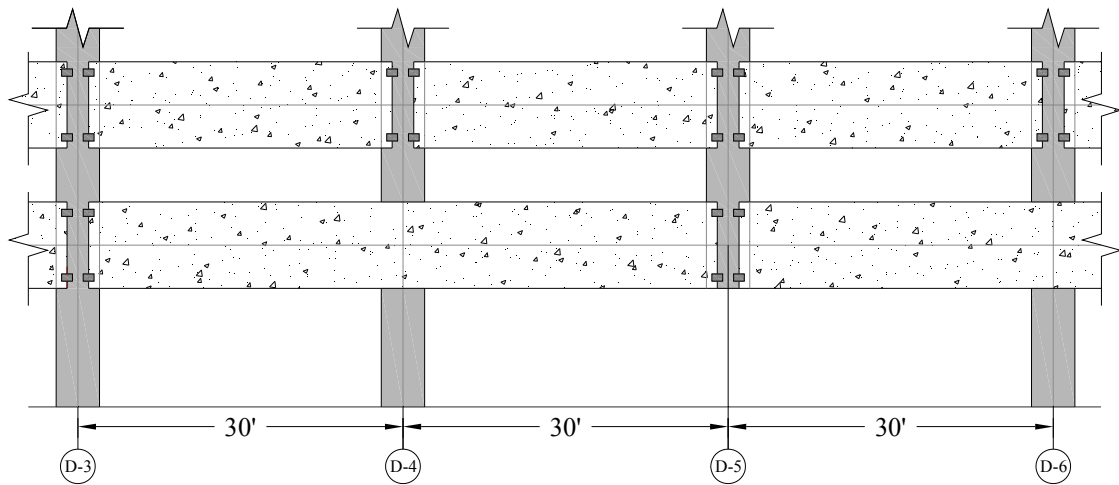

Figure 5-11: Local Elevation-D of Case 2

5.2.4 Case3: Modified Model with Fixed-fixed Beam

For case3, only one double-length continuous spandrel beams at story-1 is placed between line D4 and line D6. It is modeled as a fixed-fixed end continuous beam with double-length span to cross over the removed column. Since the connections are simulated rigidly, no difference in modeling exists between Case 1 and Case 3, as shown in Figure 5-12. As expected, the moment of the spandrel beam above the removed column develops continuously. But for the same reason as case2, the moment resistance by reinforcements in spandrel beams is more reliable than steel plates in consideration of limitations of anchorage bars. The ETABS model of Case 1 is used in this case, but the mid-span moment and shear should be checked according to spandrel beam resistance instead of steel plates. See in Figure 5-13 for continuous spandrel beam local conditions.

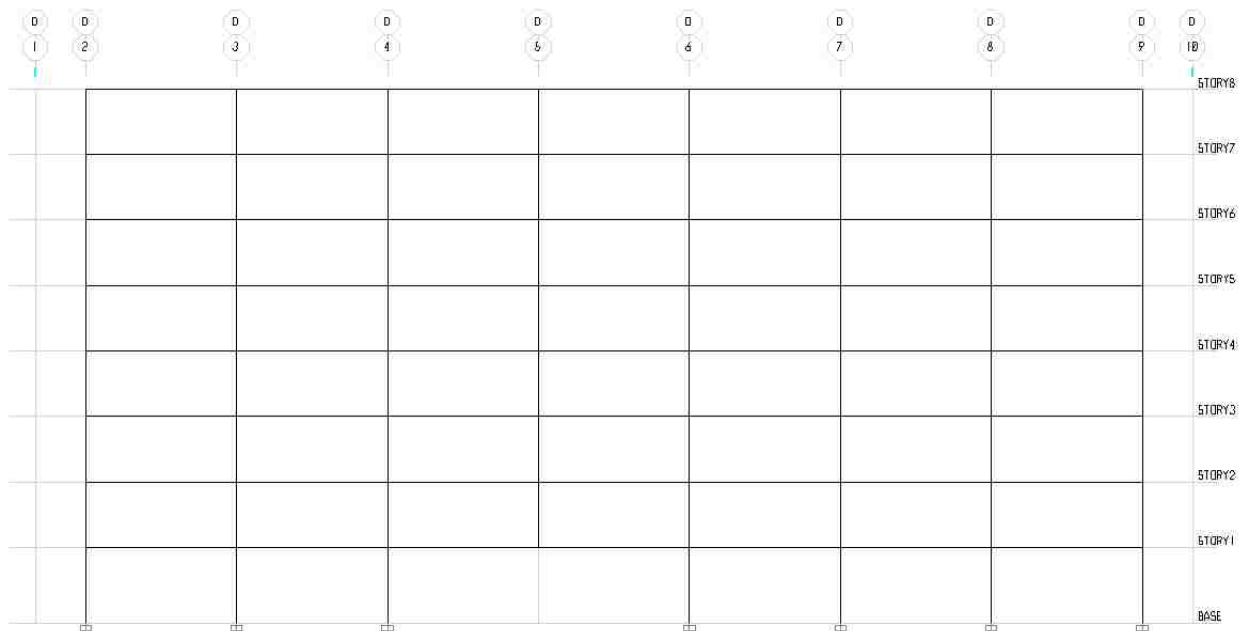

Figure 5-12: Elevation-D of model of Case 3

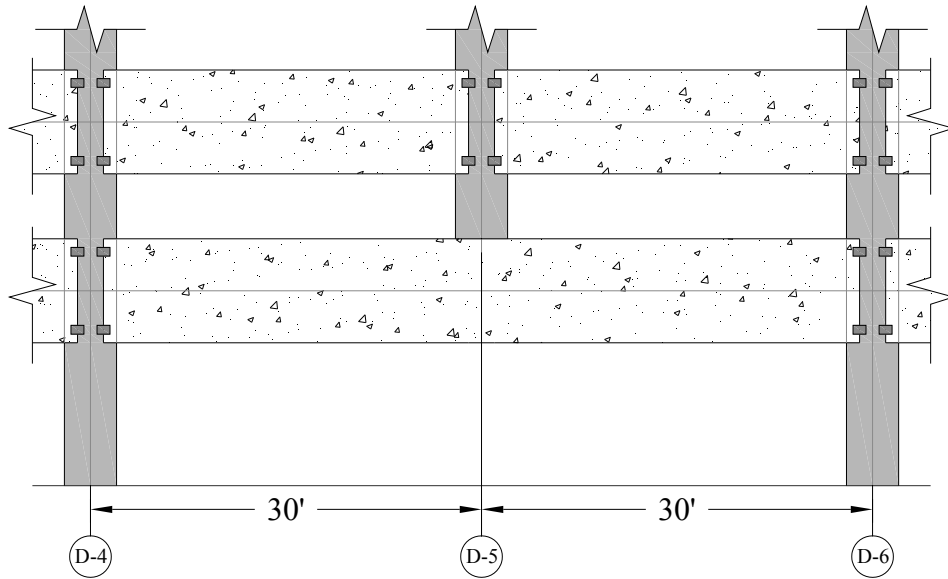

Figure 5-13: Local Elevation-D in Case 3

5.3. Analysis and Design Criteria

The U.S. General Service Administration (GSA)(GSA, Progressive Collapse Analysis and Design Guidelines, 2003) and The U.S. Department of Defense(UFC-4-023-03, 2010) are applied in this report for computer simulation about progressive collapse analysis.

5.3.1 GSA Load Combination and Acceptance Criteria

In GSA criteria, the combination of load $L = 2 \times \text{Dead Load} + 0.5 \times \text{Live Load}$ is applied over each level of the entire structure, where the dead load is 111 psf and the live load is 24 psf. Based on linear static analysis, the column considered is removed first, and then the combined load is applied statically. Accordingly, the acceptance criterion for GSA linear static procedure is depending on DCR values, namely, the demand capacity ratio. For typical structures, the accepted DCR value shall be limited within 2.0, which means the ultimate response quantity shall be less than 2 times the expected component capacity in order to satisfy the acceptance criterion. For GSA the design material strength may be increased by a

strength increase factor to determine the expected material strength. For this report, the increase factor for concrete and reinforcements is 1.25, resulting in corresponding increasing of component capacity by 1.25(GSA, Progressive Collapse Analysis and Design for New Federal Buildings and Major Modernization Projects, 2003).

5.3.2 UFC Load Combination and Acceptance Criteria

The actions in UFC are divided as deformation-controlled action and force-controlled action. The moment and axial force are included in the deformation-controlled action, and the shear force should be checked in force-controlled action. The increased load combination with the corresponding load factors is applied to those bays immediately adjacent to the removed element and all floors above the element.

In deformation-controlled action of linear static procedure of UFC, m-factor is used in determination of deformation-controlled load factor $\Omega_{LD} = 1.2 \times m_{LIF} + 0.8$, where m_{LIF} is defined as the smallest m-factor of any primary beam, girder or spandrel that is directly connected to the columns directly above the column removal location. For this case, m-factor of spandrel beams in exterior section is 1.5, and only spandrel beams are connected to the columns considered, so $m_{LIF} = 1.5$ and $\Omega_{LD} = 2.6$. The increased gravity load for floor area above removed column is expressed as $G_{LD} = 2.6 \times (0.9 \times \text{Dead Load} + 0.5 \times \text{Live Load})$. For force-controlled action, $\Omega_{LF} = 2.0$, so that the increased gravity load for floor area above removed column is expressed as $G_{LF} = 2.0 \times (0.9 \times \text{Dead Load} + 0.5 \times \text{Live Load})$. Gravity load for floor areas away from removed column for deformation-controlled action and force-controlled action is the same, which is $G = 0.9 \times \text{Dead Load} + 0.5 \times \text{Live Load}$, and the lateral loads applied to the structure is $L_{LAT} = 0.002 \times \sum P$, where $\sum P$ is defined as sum of

the gravity loads acting on only that floor, and load increased factor is not applied(UFC-4-023-03, 2010).

When checking the component if the acceptance criteria is satisfied, for deformation-controlled action, $\Phi \times m \times Q_{CE} \geq Q_{UD}$, for the force-controlled action, $\Phi \times Q_{CL} \geq Q_{UF}$, where $\Phi = 0.9$, Q_{CE} and Q_{CL} are defined as the expected strength of the components for deformation-controlled actions and the lower bound strength of components for the force-controlled actions, respectively(UFC-4-023-03, 2010)

5.3.3 General Comparison and Summary of GSA and UFC

According to GSA(GSA, Progressive Collapse Analysis and Design for New Federal Buildings and Major Moderization Projects, 2003) and UFC(UFC-4-023-03, 2010), the comparison of load combination, load applied area, and the checking items are indicated in Table 5-2.

Table 5-2: Comparison and Summary of GSA and UFC in load combination and acceptance criteria

	GSA	UFC	
		Deformation-Controlled	Force-Controlled
Load Combination	$L = 2 \times \text{Dead Load} + 0.5 \times \text{Live Load}$	$G_{LD} = 2.6 \times (0.9 \times \text{Dead Load} + 0.5 \times \text{Live Load})$	$G_{LF} = 2.0 \times (0.9 \times \text{Dead Load} + 0.5 \times \text{Live Load})$
Applied Area	Each level of the entire structure	Those bays immediately adjacent to the removed column and at all floors above the removed column	
Check	$2 \times Q_{CE} \geq Q_{UD}$	$\Phi \times m \times Q_{CE} \geq Q_{UD}$, where $m=1.5$, $\Phi = 0.9$	$\Phi \times Q_{CL} \geq Q_{UF}$, Where $\Phi = 0.9$

5.4. Results Study of Three Model Cases

Linear static procedure (LSP) is applied in the analysis of progressive collapse in this report. All the frame components are connected rigidly, except the simply supported secondary beams which represented the ribs of double tee slabs, and the over-hung sections of the continuous cantilever beam in Case 2. The column considered is removed instantaneously before loads applying. In linear static analysis, the stress-strain curvatures of primary and secondary components are developing linearly so that the structure is modeled elastically. In GSA, DCR values of beams and columns are compared with the acceptance value 2.0 for typical structures. In UFC, the expected strength and the lower bound capacity are factored and compares with the ultimate responses. If the acceptance criteria are failed to be satisfied, redesign of the elements or enhancement of the failed elements capacity is required. The following section provides details about analysis and enhancement of elements capacities.

5.4.1 Case 1: Original Model

Figure 5-14 captures the portions of Story-1 and Story-2 adjacent to the removed column in 2D-view. According to ACI-318 section 11.1.3.1, for non-prestressed members, sections located less than a distance of $d = 8\text{ft}$ from face of support, are permitted to be designed for V_u computed at a distance of $d = 8\text{ft}$ from the face of the support. So the critical section for shear checking is at a distance of 8 ft from the face of support at both ends of elements. If the shear resistance is inadequate, the shear enhancements should be applied along the whole length of the spandrel beams. Select the face at a distance of half depth, namely, 4 ft, from the face of support as the critical section for both positive moment checking and negative moment checking. The steel plates moment is checked at the connection located at a distance of 1 ft from the centroid of columns directly. The details of checking locations are presented

out by corresponding colored short lines in Figure 5-14. The pentagrams indicate where the maximum response quantity in the table is coming from. The moment and shear force distributions analyzed by ETABS are illustrated in Figure 5-15 and Figure 5-16.

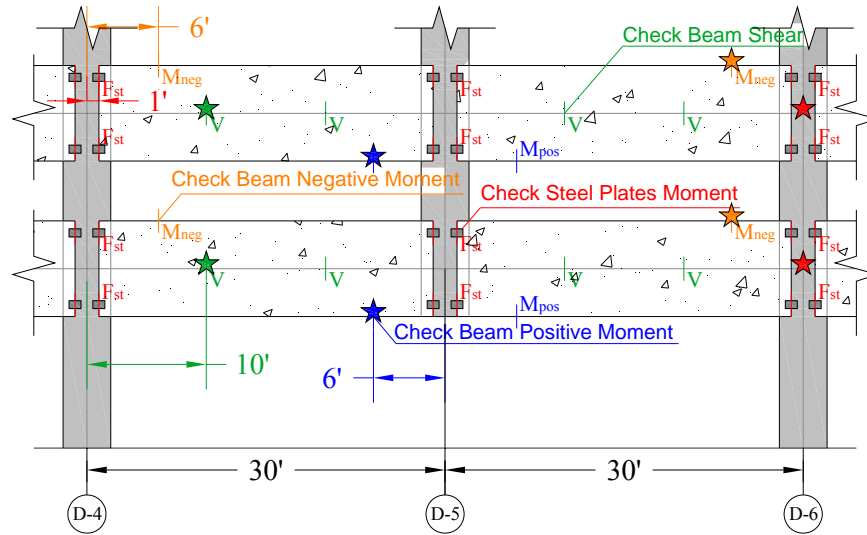

Elevation-D of Case-1

M_{neg} ---Beam negative moment checked location M_{pos} ---Beam positive moment checked location
 V ---Beam shear checked location F_{st} ---Steel plates force checked location

Figure 5-14: Detailed checking locations for each response in Case 1

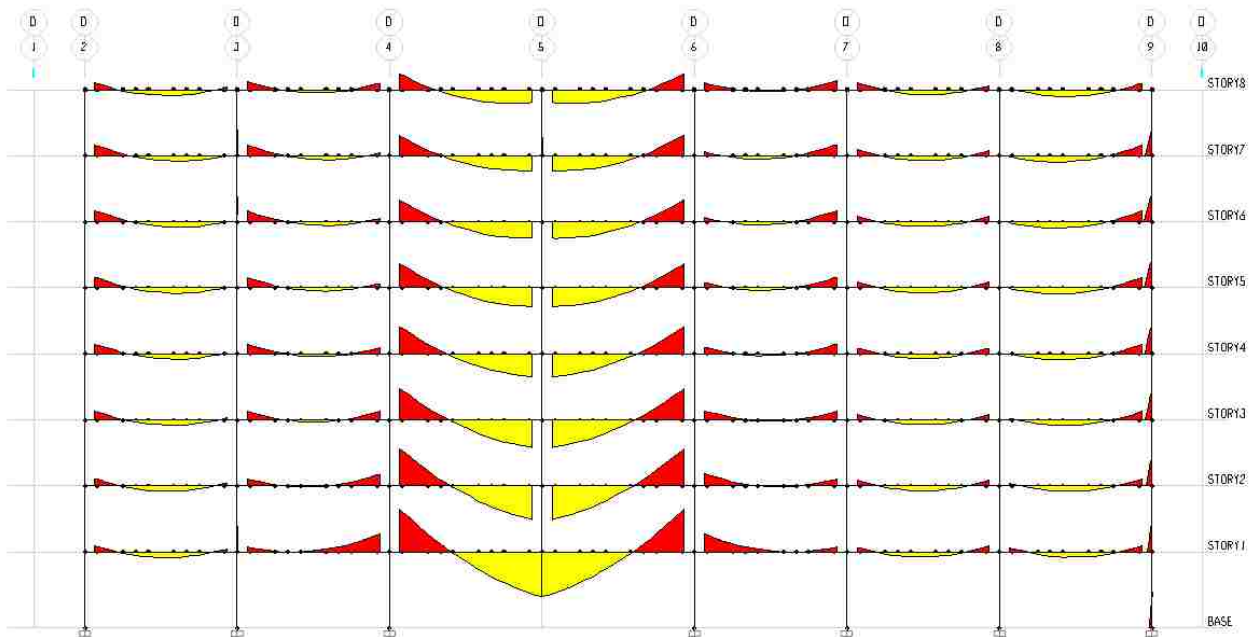

Figure 5-15: Moment distribution in Case 1

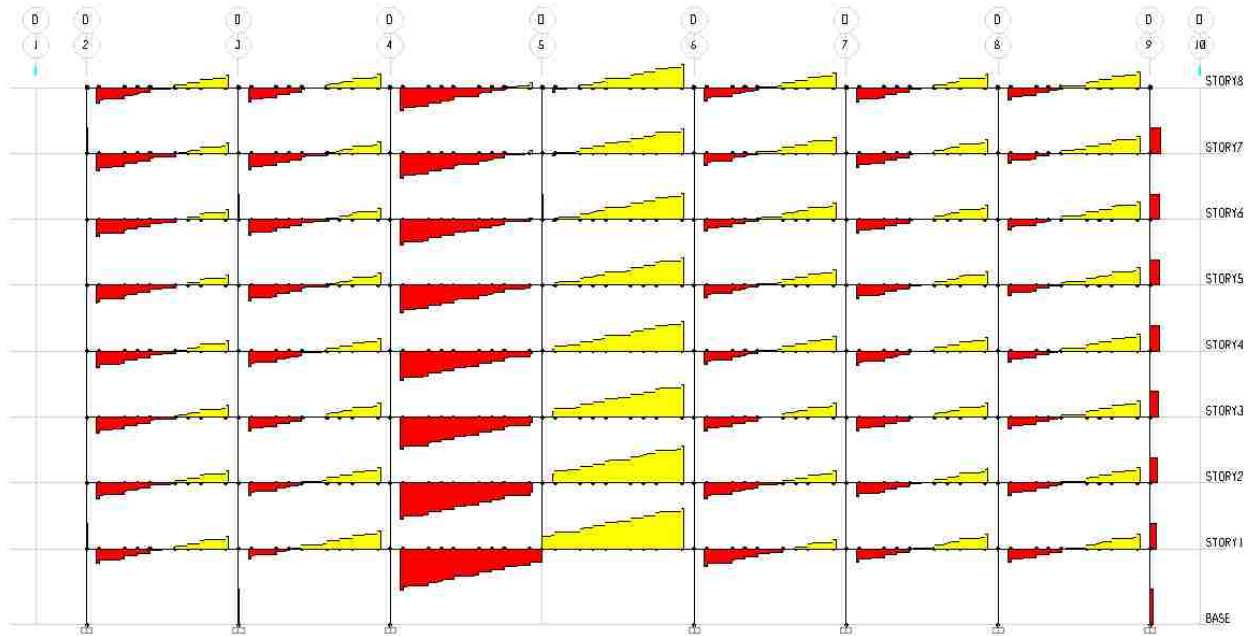

Figure 5-16: Shear force distribution in Case 1

5.4.1.1 Static Linear Analysis by GSA Requirements

5.4.1.1.1 Analysis of Results

The DCR values of components in interior section are within the acceptance limit 2.0, which means no resign or enhancement is required for interior section components, including inverted tee beams and columns. For Elevation-A where no column is removed, the components also provide adequate capacity to satisfy $DCR = \frac{Q_u}{Q_c} \leq 2.0$. For the Elevation of 1 and 10, the same conclusion is obtained. Note that in GSA requirements, the strength increased factor of 1.25 is included in the calculation of elements' expected ultimate capacities(GSA, Progressive Collapse Analysis and Design for New Federal Buidlins and Major Moderization Projects, 2003). The analysis results are presented in Table 5-3.

Table 5-3: Response of Case 1 by GSA requirements

	Elements	Response		Story							
				1	2	3	4	5	6	7	8
GSA	Spandrel Beams	Moment (kip-ft)	Positive	3349	2781	2327	1979	1723	1545	1431	1320
			Negative	2398	2053	1692	1412	1771	1062	962	640
		Shear (kip)	368	317	272	237	212	194	182	158	
	Steel Plates	Moment (kip-ft)	4668	4070	3481	3028	2694	2459	2300	1857	

5.4.1.1.1.1 *Steel Plates*

For beams at story 1 directly above the removed column in Elevation of D, the negative moment at the face of beam-beam connection acted on steel plates is 4668 kip-ft, which is less than 2 times the expected ultimate moment capacity. In other words, the DCR values of the beam-beam connections satisfy the acceptance limit 2.0, so no redesign is required.

$$M_U = 4668 \text{ kip} - \text{ft}$$

$$M_{CP} = 2088 \text{ kip} - \text{ft} \times 1.25 = 2610 \text{ kip} - \text{ft}$$

$$DCR = \frac{M_U}{M_{CP}} = 1.8 < 2.0$$

5.4.1.1.1.2 *Spandrel Beams*

The critical section to check spandrel beam moment is located at a distance of $d = 4\text{ft}$ from the face of the support. From the table of results, the maximum positive moment acted on the spandrel beams of Story-1, which is 3349 kip-ft, is within the acceptance limit of 3820 kip-ft. Thus, no additional reinforcements are required to increase the positive moment capacity of the spandrel beams in this case. However, the negative moment of 2398 kip-ft acted at the

critical section of the same element is exceeding the acceptance limit. Similarly, the negative moment acted on the second floor is beyond the limited value as well.

For Story-1 about Positive Moment:

$$M_{UD} = 3349 \text{ kip} - \text{ft}$$

$$M_{CE} = 1528 \text{ kip} - \text{ft} \times 1.25 = 1910 \text{ kip} - \text{ft}$$

$$DCR = \frac{M_{UD}}{M_{CE}} = 1.75 < 2.0$$

For Story-1 about Negative Moment:

$$M_{UD} = 2398 \text{ kip} - \text{ft}$$

$$M_{CE} = 943 \text{ kip} - \text{ft} \times 1.25 = 1179 \text{ kip} - \text{ft}$$

$$DCR = \frac{M_{UD}}{M_{CE}} = 2.03 > 2.0$$

The steel plates are assumed to provide the adequate shear resistance, the shear failure conditions should be checked only in the spandrel beams. Since the shear critical section is at a distance of 8 ft from the face of the support, the shear force located at 10 ft from column centroid at Story-1 is checked. From the table, the critical shear force is 368 kip, which is much smaller than two times expected shear resistance, namely, 632 kip. For the beams above Story-1, the same conclusions are obtained. Therefore, no more shear resistance is required in this case. Actually, this also matches the requirement of “strong shear, weak bending”.

5.4.1.1.2 Modification about Redesign

For the spandrel beams at Story-2 and Story-2, the negative capacities provided by the spandrel beams should be increased. Adding 2-#8 bars at the top of the cross section at Story-1 and Story-2 will increase the negative moment capacity to 2022 kip-ft produced by 2-#8 bars and 2-#6 bars, which satisfies the requirement.

$$M_{UD} = 2398 \text{kip} - \text{ft}$$

$$M_{CE} = 2022 \text{kip} - \text{ft}$$

$$DCR = \frac{M_{UD}}{M_{CE}} = 1.2 < 2.0$$

Since the spandrel beams can provide adequate shear resistance, no more enhancement or redesign is required for this case based on GSA.

5.4.1.2 Static Linear Analysis by UFC Requirements

5.4.1.2.1 Analysis of Results

In this case, DCR values are not required in Static Linear Analysis by UFC criterion. Instead, $\Phi \times m \times Q_{CE} \geq Q_{UD}$, where $\Phi = 0.9$ and $m = 1.5$, should be satisfied for deformation-controlled actions in order to reduce possibilities of redesign or enhancement. Similarly, for force-controlled actions, $\Phi \times Q_{CL} \geq Q_{UF}$ should be satisfied (UFC-4-023-03, 2010). By running analysis of linear static procedure, the factored response quantities of components, except those in Elevation of D, are within the acceptance limit for deformation-controlled action and force-controlled action. In Table 5-4 the colored boxes represent those responses which are beyond the resistance capacity. The analysis results are shown in Table 5-4.

Table 5-4: Response of Case 1 by UFC requirements

	Elements	Response		Story							
				1	2	3	4	5	6	7	8
UFC	Spandrel Beams	Moment (kip-ft)	Positive	2150	1810	1514	1289	1123	1007	933	861
			Negative	1506	1335	1097	914	782	687	624	412
		Shear (kip)	336	296	260	233	213	198	188	163	
	Steel Plates	Moment (kip-ft)	3152	2620	2232	1938	1721	1569	1465	1177	

5.4.1.2.1.1 *Steel Plates*

At the first level of Elevation-D, the negative moment acted at the face of beam-beam connection of steel plates in the line D-4 above the removed column fails to satisfy the acceptance criteria. The moment response belongs to the group of deformation-controlled action. The acted negative moment is 3541 kip-ft, but the factored expected moment provided by steel plates is 2820 kip-ft. The positive moment at the connection directly above the removed column is less than 3152 kip-ft, so the critical moment is 3152 kip-ft.

$$\Phi \times m \times M_{CE} = 0.9 \times 1.5 \times 2088 \text{ kip} - \text{ft} = 2820 \text{ kip} - \text{ft}$$

$$M_{UD} = 3152 \text{ kip} - \text{ft} > 1749 \text{ kip} - \text{ft}$$

5.4.1.2.1.2 *Spandrel Beams*

Similar as the analysis under GSA requirements, select the section at a distance of $d = 4\text{ft}$ from the face of the support as the critical section for moment checking. From the table of results, the maximum positive and negative moment acted on the spandrel beams of Story-1 are 2150 kip-ft and 1506 kip-ft, respectively, which are beyond the acceptance limits as presented below. Thus, no additional reinforcements are required to increase the positive moment capacity of the spandrel beams in this case. In the same way, the negative moment at

Story-2, which is 1335 kip-ft, also exceeds the factored negative moment capacity provided by the spandrel beams.

For Story-1 about Positive Moment:

$$M_U = 2150 \text{ kip} - \text{ft}$$

$$M_{CB} = 1528 \text{ kip} - \text{ft} \times 1.5 \times 0.9 = 2063 \text{ kip} - \text{ft} < M_U = 2150 \text{ kip} - \text{ft}$$

For Story-1 about Negative Moment:

$$M_U = 1506 \text{ kip} - \text{ft}$$

$$M_{CB} = 943 \text{ kip} - \text{ft} \times 1.5 \times 0.9 = 1273 \text{ kip} - \text{ft} < M_U = 1506 \text{ kip} - \text{ft}$$

The shear forces acted at the critical sections in the spandrel beams of Story-1 are about 336 kip, greater than the factored expected shear capacity $\Phi \times Q_{CL} = 0.9 \times 316 \text{ kip} = 284 \text{ kip}$. Similarly, the shear force acted in the beam at Story-2, which is 296 kip, is also exceeding the acceptance value of shear capacity. Fortunately, the shear forces above Story-2 satisfy the acceptance criteria. Thus, the beams of Story-1 and Story-2 need to be modified to satisfy the requirements.

$$\Phi \times V_{CE} = 0.9 \times 316 \text{ kip} = 284 \text{ kip}$$

For Story-1:

$$V_{UD} = 336 \text{ kip} > 284 \text{ kip}$$

For Story-2:

$$V_{UD} = 296 \text{ kip} > 284 \text{ kip}$$

5.4.1.2.2 Modification about Redesign

Based on the analysis of results above, redesign is necessary for progressive collapse resistance. Different from the GSA case, the steel plates of Story-1 should be improved to increase moment capacity base on the UFC criterion. Apparently, UFC criterion provides a more conservative requirement in progressive collapse resistance than GSA does. Because the negative moment acted at the connections of Story-1 is greater than other levels, take the Story-1 as an example based on conservative consideration. As a result, the plate depth should be increased to 12 in. Thus, the maximum tension is increasing to 450 kip and the corresponding expected moment capacity reaches to 2700 kip-ft. The calculation details are presented as follows. This shall be exerted to the same connections of Story 2-4 as well.

$$F_{ST} = 12\text{in} \times 0.75\text{ in} \times 58\text{ ksi} = 522\text{ kip}$$

$$M_{CE} = F_{ST} \times 6\text{ ft} = 3132\text{ kip} - \text{ft}$$

$$\Phi \times m \times M_{CE} = 0.9 \times 1.5 \times 3132\text{kip} - \text{ft} = 4230\text{ kip} - \text{ft} > M_{UD} = 3541\text{ kip} - \text{ft}$$

For the bottom section of spandrel beams at Story-1, the bottom 2-#6 bars should be replaced by 2-#8 bars in order to satisfy the requirements. So the increased positive moment capacity is now 2018 kip-ft. Similarly, adding 2-#6 bars at the top of the cross section at Story-1 and Story-2 will increase the negative moment capacity to 1528 kip-ft, which satisfies the requirement.

Additionally, the shear capacities of beams at Story-1 and Story-2 are also needed to be improved. Based on $V_s = \frac{A_v \times f_{yt} \times d}{s}$, if using #5 bars with 2-leg placed at every 12in in the middle third section, instead of #4 bars, the shear capacity provided by reinforcing bars will be 288 kip. Therefore, the total shear capacity is 418 kip, the factored shear resistance of the

spandrel beams will increase to 376 kip, which is greater than the maximum shear force, 336 kip.

Fortunately, another factor of deformation-controlled action, namely, the axial forces acted in the columns, are not exceeding the acceptance limit. Thus, the columns will not be failed by axial forces and the beam will not be failed by shear.

5.4.1.3 Comparison of GSA and UFC

5.4.1.3.1 Results Comparison

Based on the results, the shaded area represents the elements of the corresponding stories which are needed to be redesigned. According to Table 5-5, the design for the new buildings or redesign and enhancement for the existing building based upon UFC is more conservative than on GSA, since more elements need to be considered.

Table 5-5: Summary of response of Case 1 by GSA and UFC requirements

	Elements	Response		Story							
				1	2	3	4	5	6	7	8
GSA	Spandrel Beams	Moment (kip-ft)	Positive	3349	2781	2327	1979	1723	1545	1431	1320
			Negative	2398	2053	1692	1412	1771	1062	962	640
		Shear (kip)		368	317	272	237	212	194	182	158
	Steel Plates	Moment (kip-ft)		4668	4070	3481	3028	2694	2459	2300	1857
UFC	Spandrel Beams	Moment (kip-ft)	Positive	2150	1810	1514	1289	1123	1007	933	861
			Negative	1506	1335	1097	914	782	687	624	412
		Shear (kip)		336	296	260	233	213	198	188	163
	Steel Plates	Moment (kip-ft)		3152	2620	2232	1938	1721	1569	1465	1177

5.4.1.3.2 Redesign or Enhancement Comparison

The following table provides modified details for spandrel beams and steel plates in shaded boxes. The information presented in the blank boxes is the same as the original design, as shown in Table 5-6.

Table 5-6: Summarized modification details of Case 1 by GSA and UFC requirements

	Element	Location		Story		
				1	2	3-8
GSA	Spandrel Beams	Longitudinal Reinforcement	Bot	4-#6 Bars		
			Top	4-#6 Bars	2-#6 Bars	
		Transverse Bars	#4 bars @ 12in with 2-leg			
	Steel Plates	Depth of Plates	d=8in, $f_{yt} = 36\text{ksi}$			
		Strength of Material				
UFC	Spandrel Beams	Longitudinal Reinforcement	Bot	2-#8, 2-#6	4-#6 Bars	
			Top	4-#6 Bars	2-#6 Bars	
		Transverse Bars	2-#5 bars @ 12in	2-#4 bars @ 12in		
	Steel Plates	Depth of Plates	d=12in, $f_{yt} = 36\text{ksi}$	d=8in, $f_{yt} = 36\text{ksi}$		
		Strength of Material				

5.4.2 Case 2: Modified Model with Cantilever Beams

From Figure 5-17 below, the checking items and the corresponding locations of Story-1 are different from those of Story-2, according to behaviors of continuous beams. However, those considerations are same from Story-2 to Story-8, so selection of Story-1 and Story-2 represents the consideration about the entire elevation of D. The moment and shear force distributions analyzed by ETABS are illustrated in Figure 5-18 and Figure 5-19.

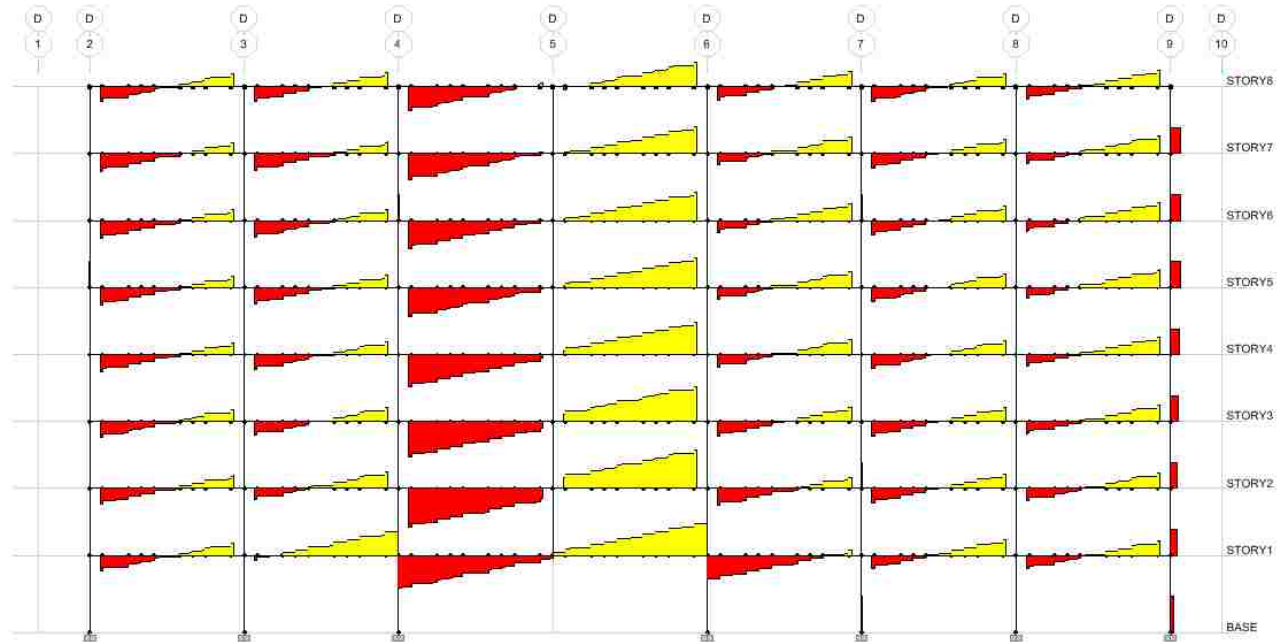

Figure 5-19: Shear force distribution in Case 2

5.4.2.1 Static Linear Analysis by GSA Requirements

5.4.2.1.1 Analysis of Results

Based on the same acceptance criteria of GSA as discussed in the original model case, the detailed calculations about element capacities and enhancement information are presented in the following section. See in Table 5-7 for analysis results by ETABS.

Table 5-7: Response of Case 2 by GSA requirements

	Elements	Response		Story							
				1	2	3	4	5	6	7	8
GSA	Continuous Spandrel Beams	Moment (kip-ft)	Positive	2235	3040	2568	2189	1906	1710	1583	1460
			Negative	3531	2093	1844	1553	1326	1167	1058	701
		Shear (kip)	275	356	293	257	228	209	195	169	
	Steel Plates	Moment (kip-ft)	2586	4192	3744	3265	2898	2639	2464	1975	

5.4.2.1.1.1 Steel Plates

For beams at Story-1 of Elevation-D directly above the removed column, the negative moment at the face of beam-to-beam connection acted on steel plates is 2586 kip-ft, which is less than 2 times the expected ultimate moment capacity. In other words, the DCR values of the beam-beam connections is within the acceptance limit 2.0, therefore, modification for this connection is not required. Similarly, at story 2 the negative moment of the connection acted on steel plates is 4192 kip-ft, the corresponding DCR values of the beam-to-beam connections is also within the acceptance limit 2.0, so it is not required to redesign the steel plated or make an enhancement of the plate's capacities. The similar conditions are also presented in upper levels. Again, the shear capacity provided by the steel plates is adequate as assumed.

$$M_{CE} = 2088 \text{ kip} - \text{ft} \times 1.25 = 2610 \text{ kip} - \text{ft}$$

At Story-1:

$$M_U = 2586 \text{ kip} - \text{ft}$$

$$\text{DCR} = \frac{M_U}{M_{CP}} = 1 < 2.0$$

At Story-2:

$$M_U = 4192 \text{ kip} - \text{ft}$$

$$\text{DCR} = \frac{M_U}{M_{CP}} = 1.6 < 2.0$$

5.4.2.1.1.2 Spandrel Beams

It is the same as the original model that the critical section is at a distance of $d = 4\text{ft}$ from the face of the support. For this case, the double-length continuous beam has continuous moment acted at the connection to the columns in Line-D4 or D6, so the maximum negative moment for Story-1 is located at that connection. As shown in the table, the maximum negative moment is equal to 3531 kip-ft, greater than two times 1179 kip-ft, namely, 2358 kip-ft, the acceptance limit. Fortunately, the negative moments of the continuous beams above Story-1 are all within the acceptance limit. From the table of results, the positive moment acted on the spandrel beams of Story-1 is 2235 kip-ft, within the acceptance limit of 3820 kip-ft. Thus, no additional reinforcements are required.

For Story-1 about Positive Moment:

$$M_U = 2235 \text{ kip} - \text{ft}$$

$$M_{CB} = 1528 \text{ kip} - \text{ft} \times 1.25 = 1910 \text{ kip} - \text{ft}$$

$$DCR = \frac{M_U}{M_{CB}} = 1.17 < 2.0$$

For Story-1 about Negative Moment:

$$M_U = 3531 \text{ kip} - \text{ft}$$

$$M_{CB} = 943 \text{ kip} - \text{ft} \times 1.25 = 1179 \text{ kip} - \text{ft}$$

$$DCR = \frac{M_U}{M_{CB}} = 3.0 > 2.0$$

Since the steel plates are assumed to provide the adequate shear resistance, the shear failure conditions should be checked only in the spandrel beams. As discussed in the original model

case, the critical section of shear computation is at a distance $d=8$ ft from the face of the support. Therefore, the corresponding shear force of Story-1 is about 275 kip, which is much smaller than two times expected shear resistance, namely, 632 kip. For the beams at Story-2, even though the shear force acted at the critical section reaches 334 kip, greater than that of Story-1, it is still within the acceptance limit of 632 kip. For the beams above Story-2, the same conclusions are obtained. Therefore, no more shear resistance is required in this case. Actually, this also matches the requirement of “strong shear, weak bending”.

5.4.2.1.2 Modification about Redesign

For the spandrel beams at Story-1, adding 2-#6 bars at the top of the cross results in increasing the negative moment capacity to 1528 kip-ft, which satisfies the requirement.

$$M_U = 3531 \text{ kip} - \text{ft}$$

$$M_{CB} = 1528 \text{ kip} - \text{ft} \times 1.25 = 1910 \text{ kip} - \text{ft}$$

$$\text{DCR} = \frac{M_U}{M_{CB}} = 1.85 < 2.0$$

Since the spandrel beams can provide adequate shear resistance and positive moment resistance, no more enhancement or redesign is required for this case based on GSA.

5.4.2.2 *Static Linear Analysis by UFC Requirements*

5.4.2.2.1 Analysis of Results

Based on the same acceptance criteria of UFC as discussed in the original model case, the detailed calculations about elements' capacities and enhancement information are presented in the following section. The components response results are presented in Table 5-8.

Table 5-8: Response of Case 2 by UFC requirements

	Elements	Response		Story							
				1	2	3	4	5	6	7	8
UFC	Continuous Spandrel Beams	Moment (kip-ft)	Positive	2277	3139	2725	2390	2141	1970	1860	1724
			Negative	3355	2052	1846	1576	1365	1218	1109	637
		Shear (kip)	235	289	258	228	206	190	180	152	
	Steel Plates	Moment (kip-ft)	2534	4222	3844	3406	3067	2830	2662	2021	

5.4.2.2.1.1 Steel Plates

The steel plates from Story-2 to Story-6 in this case are required to make modifications. For Story-1, the steel plates considered are located above the removed column directly; but for above stories, the steel plates considered are at the other ends of the spandrel beams. At Story-1, the positive moment considered is 2534 kip-ft, and the steel plates' ultimate moment capacity is only 2088 kip-ft with the corresponding factored expected ultimate moment capacity of 2820 kip-ft, which is greater than 2534 kip-ft. Basically, the moment response is included in deformation-controlled action. However, for Story-2 the negative moment is 4222 kip-ft, which much greater than the factored expected moment capacity of 1749 kip-ft. Similar conclusions can be obtained from the stories above.

$$\Phi \times m \times M_{CE} = 0.9 \times 1.5 \times 2088 \text{ kip} - \text{ft} = 2820 \text{ kip} - \text{ft}$$

At Story-1:

$$M_{UD} = 2534 \text{kip} - \text{ft} < 2820 \text{ kip} - \text{ft}$$

At Story-2:

$$M_{UD} = 4222 \text{kip} - \text{ft} < 2820 \text{kip} - \text{ft}$$

5.4.2.2.1.2 Spandrel Beams

Similar as the analysis under GSA requirement, select the section at a distance of $d = 4\text{ft}$ from the face of the support as the critical section. From the table of results, the greater negative moment acted on the pinned connections to the columns in Line D-4 and Line is 3355 kip-ft at Story-1, which is beyond the acceptance limits as presented below. The greater positive moment along the length of the continuous beam at the critical sections is 2277 kip-ft for Story-1 and 3139 kip-ft for Story-2. Obviously, these two values are beyond the acceptance as detailed below. In conclusion, the positive moment capacities are beyond from Story-1 to Story-7, and the negative moment capacities are exceeded from Story-1 to Story-6.

For Story-1 about Positive Moment:

$$M_U = 2277 \text{ kip} - \text{ft}$$

$$M_{CB} = 1528 \text{ kip} - \text{ft} \times 1.5 \times 0.9 = 2063 \text{ kip} - \text{ft} < M_U = 2277 \text{ kip} - \text{ft}$$

For Story-2 about Positive Moment:

$$M_U = 3139 \text{ kip} - \text{ft}$$

$$M_{CB} = 1528 \text{ kip} - \text{ft} \times 1.5 \times 0.9 = 2063 \text{ kip} - \text{ft} < M_U = 3139 \text{ kip} - \text{ft}$$

For Story-1 about Negative Moment:

$$M_U = 3355 \text{ kip} - \text{ft}$$

$$M_{CB} = 943 \text{ kip} - \text{ft} \times 1.5 \times 0.9 = 1273 \text{ kip} - \text{ft} < M_U = 3355 \text{ kip} - \text{ft}$$

For Story-2 about Negative Moment:

$$M_U = 2052 \text{ kip} - \text{ft}$$

$$M_{CB} = 943 \text{ kip} - \text{ft} \times 1.5 \times 0.9 = 1273 \text{ kip} - \text{ft} < M_U = 2052 \text{ kip} - \text{ft}$$

The shear forces acted at the critical sections in the spandrel beams of Story-2 are about 289 kip, a little bit greater than the factored expected shear capacity $\Phi \times Q_{CL} = 0.9 \times 316 \text{kip} = 284 \text{kip}$. Fortunately, the shear force of 235 kip acted in the beam at Story-1 is within the acceptance value of shear capacity. Thus, the beams of Story-2 need to be modified with shear capacities. Different from the original model case in shear resistance under UFC requirements, the beams needed to increase its shear capacities in cantilever beam model is only located at Story-2. The more important point is shear capacities provided by the Story-1 beams are adequate to resist shear failure, which prevents the occurrence of brittle failure of spandrel beams.

For Story-1:

$$\Phi \times V_{CE} = 0.9 \times 316 \text{ kip} = 284 \text{ kip}$$

$$V_{UD} = 235 \text{ kip} < 284 \text{ kip}$$

For Story-2:

$$V_{UD} = 289 \text{ kip} > 284 \text{ kip}$$

5.4.2.2.2 Modification about Redesign

Based on analysis above, redesign or enhancement is necessary for progressive collapse resistance. Compared with GSA procedure, the story levels, where the steel plates should be improved to increase moment capacity, are rising from Story-2 to Story-6 which proves that the UFC criterion provides a more conservative requirement in progressive collapse resistance than GSA does. Because the negative moment acted at the connections of Story-2 is greater than the above Stories, take the Story-2 as an example based on conservative consideration. As a result, the plate depth should be increased to 12 in. Thus, the maximum

tension is increasing to 540 kip and the corresponding expected moment capacity reaches to 3132 kip-ft. The calculation details are presented as follows. This shall be exerted to the same connections for above stories as well.

At Story-2:

$$F_T = 12\text{in} \times 0.75\text{ in} \times 58\text{ ksi} = 540\text{ kip}$$

$$M_C = F_T \times 6\text{ ft} = 3132\text{ kip} - \text{ft}$$

$$\Phi \times m \times M_{CE} = 0.9 \times 1.5 \times 3132\text{ kip} - \text{ft} = 4228\text{ kip} - \text{ft} > M_{UD} = 4222\text{ kip} - \text{ft}$$

For the bottom section of spandrel beams at Story-1, the bottom 2-#6 bars should be replaced by 2-#8 bars in order to satisfy the requirements. So the increased positive moment capacity is now 2018 kip-ft. Similarly, using 2-#10 and 2-#8 bars at the top of the cross section at Story-1 will increase the negative moment capacity to 3100kip-ft, which satisfies the requirement. Other modification details are available in the table.

Additionally, the shear capacities of beams at Story-2 are also needed to be improved. Based on $V_S = \frac{A_v \times f_{yt} \times d}{s}$, if using #5 bars with 2-leg placed at every 12in in the middle third section, instead of #4 bars, the shear capacity provided by reinforcing bars will be 288 kip. Therefore, the total shear capacity is 418 kip, the factored shear resistance of the spandrel beams will increase to 376 kip, which is greater than the maximum shear force, 289 kip.

Fortunately, another factor of deformation-controlled action, namely, the axial forces acted in the columns, are not exceeding the acceptance limit. Thus, the columns will not be failed by axial forces and the beam will not be failed by shear.

5.4.2.3 Comparison of GSA and UFC

5.4.2.3.1 Results Comparison

Based on the results corresponding to GSA and UFC from the table below, apparently, the requirements of UFC are higher than GSA. The shaded area represents the elements at the corresponding stories which are needed to be redesigned. According to this table, the design for the new buildings or redesign and enhancement for the existing building based upon UFC is more conservative than on GSA, since more elements need to be considered. See in Table 5-9 for combination of detailed response results in GSA and UFC.

Table 5-9: Summary of response of Case 2 by GSA and UFC requirements

	Elements	Response		Story							
				1	2	3	4	5	6	7	8
GSA	Continuous Spandrel Beams	Moment (kip-ft)	Positive	2235	3045	2568	2189	1906	1710	1583	1460
			Negative	3531	2093	1844	1553	1326	1167	1058	701
		Shear (kip)	275	334	293	257	228	209	195	169	
	Steel Plates	Moment (kip-ft)		2586	4192	3744	3265	2898	2639	2464	1975
UFC	Continuous Spandrel Beams	Moment (kip-ft)	Positive	2277	3139	2725	2390	2141	1970	1860	1724
			Negative	3355	2052	1846	1576	1365	1218	1109	637
		Shear (kip)	235	289	258	228	206	190	180	152	
		Steel Plates	Moment (kip-ft)		2534	4222	3844	3406	3067	2830	2662

5.4.2.3.2 Redesign or Enhancement Comparison

The following table provides modified details for spandrel beams and steel plates in colored boxes (the original design is shown in the highlighted boxes). The information presented in the blank boxes is the same as the original design. Table 5-10 provides the modification details of Case 2 under GSA requirements and UFC requirements.

Table 5-10: Summarized modification details of Case 2 by GSA and UFC requirements

	Elements			Story				
				1	2	3-6	7	8
GSA	Spandrel Beams	Longitudinal Reinforcement	Bot	4-#6 Bars				
			Top	2-#8, 2-#6	2-#6 Bars			
		Transverse Bars	2-#4 bars @ 12in					
	Steel Plates	Depth of Plates Strength of Material		d=8in, $f_{yt} = 36\text{ksi}$				
UFC	Spandrel Beams	Longitudinal Reinforcement	Bot	2-#8, 2-#6	2-#10, 2-#6			4-#6Bars
			Top	2-#10,2-#8	2-#8, 2-#6		2-#6	
		Transverse Bars	2-#4@12in	2-#5@12in	2-#4@12in			
	Steel Plates	Depth of Plates, Strength of Material		d=8in, $f_{yt} = 36\text{ksi}$	d=12in, $f_{yt} = 36\text{ksi}$		d=8in, $f_{yt} = 36\text{ksi}$	

5.4.3 Case 3: Modified Model with Fixed-fixed Beam

The checking items and corresponding locations are covered in Figure 5-20 as same as Case 1 and Case 2. Since the double-length continuous beams are placed instead of single beams, the mid-span positive moment is checked of the continuous beam at Story-1. The model simulated in ETABS is the same as Case 1, so the force and moment results are applicable from Case 1, as shown in Figure 5-21 and Figure 5-22.

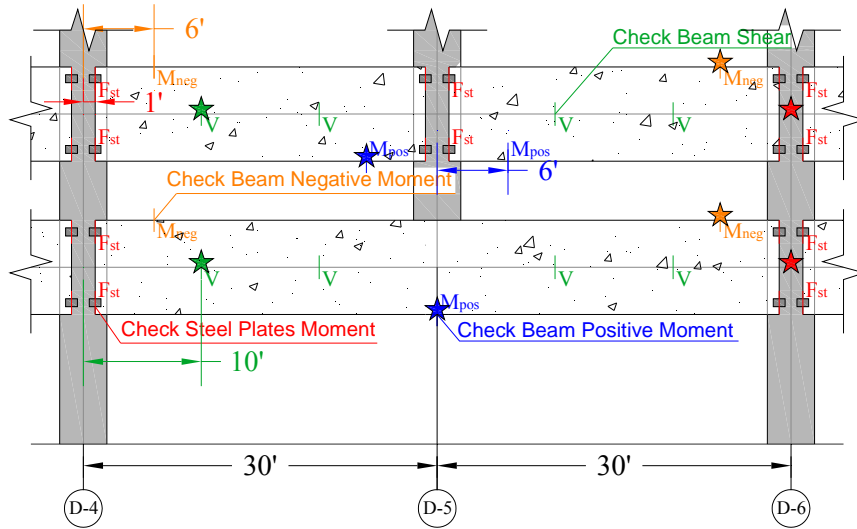

Elevation-D of Case-3

M_{neg} ---Beam negative moment checked loaction M_{pos} ---Beam positive moment checked loaction
 V ---Beam shear checked loaction F_{st} ---Steel plates force checked loaction

Figure 5-20: Detailed checking locations for each response in Case 3

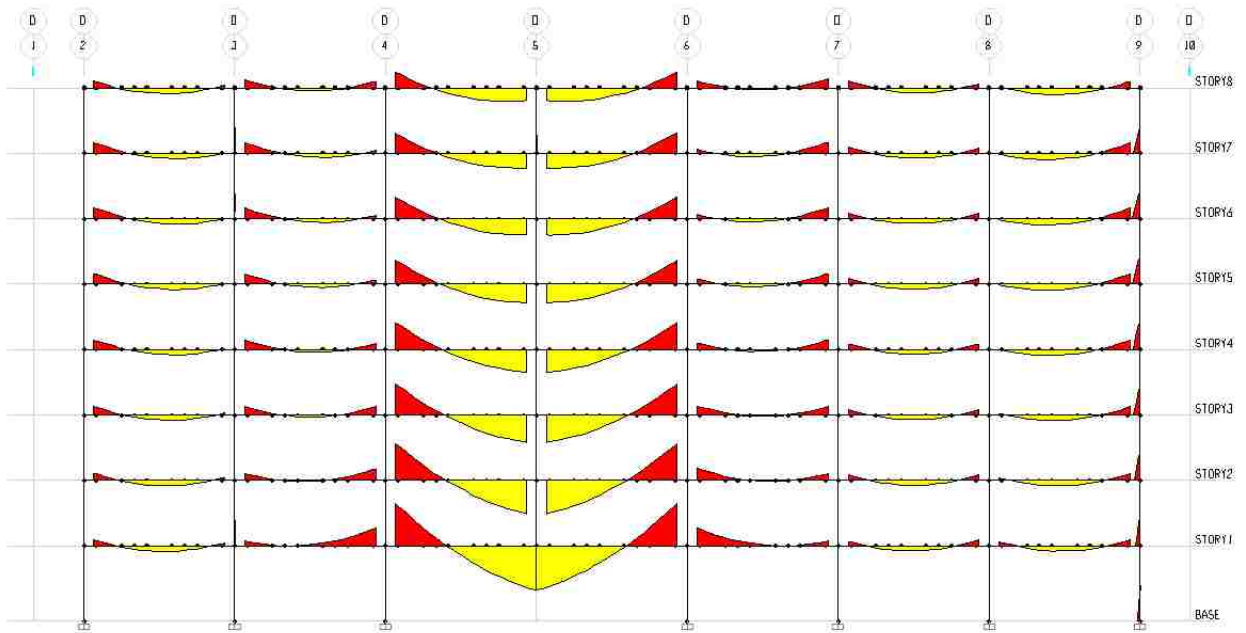

Figure 5-21: Moment distribution in Case 3

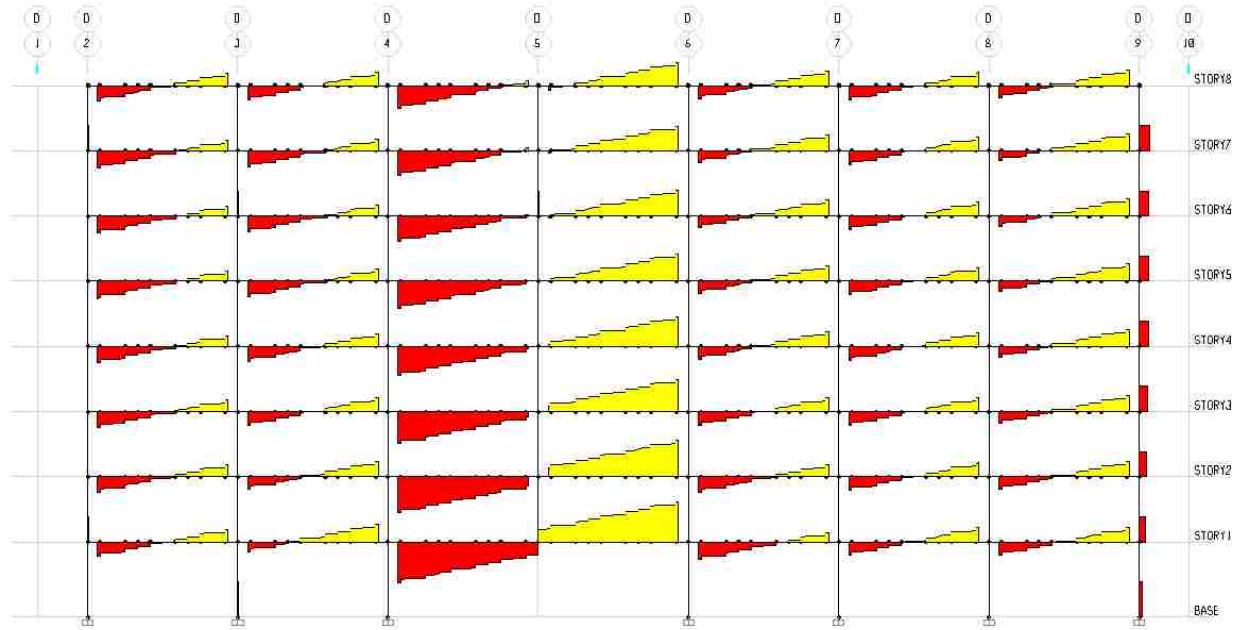

Figure 5-22: Shear force distribution in Case 3

5.4.3.1 Analysis of Results

As discussed in section 5.1.3 about system model, the model of case 3 is the same as Case 1 in ETABS. However, since the two single spandrel beams directly above the removed column are replaced by one continuous spandrel beam which cross over that column, the positive moment of the spandrel beam at the connection should be considered, instead of the steel plates' moment. As presented below, in GSA calculation, the positive moment of the beam at the mid-span is 4429 kip-ft, which is also the largest value of positive moment along the beam length. In UFC, the same quantity has a value of 4358 kip-ft.

5.4.3.2 Modification about Redesign

Since the two single spandrel beams above the removed column directly are replaced by one continuous spandrel beam, the positive moment of the continuous beam at mid-span is checked based upon GSA and UFC. For the GSA requirement, placing 2-#8 and 2-#6 bars at the bottom of the cross section instead of 4-#6 bars increases the positive moment capacity to

2018 kip-ft. Therefore, the expected positive moment with material strength increased factor of 1.25 is up to 2522.5 kip-ft, which is greater than half of the maximum positive moment of 4429 kip-ft at Story-1. In the same way, the bottom bars should be modified as 4-#10 bars at Story-1 complying with UFC requirement.

5.4.3.3 Comparison of GSA and UFC

5.4.3.3.1 Results Comparison

Based on the results corresponding to GSA and UFC from Table 5-11, apparently, the requirements of UFC are higher than GSA. The shaded area represents the elements at the corresponding stories which are needed to be redesigned. According to this table, the design for the new buildings or redesign and enhancement for the existing building based upon UFC is more conservative than on GSA, since more elements need to be considered.

Table 5-11: Summary of response of Case 3 by GSA and UFC requirements

	Elements	Response		Story							
				1	2	3	4	5	6	7	8
GSA	Spandrel Beams	Moment (kip-ft)	Positive	4429	2781	2327	1979	1723	1545	1431	1320
			Negative	2398	2053	1692	1412	1771	1062	962	640
		Shear (kip)		368	317	272	237	212	194	182	158
	Steel Plates	Moment (kip-ft)		4668	4070	3481	3028	2694	2459	2300	1857
UFC	Spandrel Beams	Moment (kip-ft)	Positive	4358	1810	1514	1289	1123	1007	933	861
			Negative	1506	1335	1097	914	782	687	624	412
		Shear (kip)		336	296	260	233	213	198	188	163
	Steel Plates	Moment (kip-ft)		3152	2620	2232	1938	1721	1569	1465	1177

5.4.3.3.2 Redesign or Enhancement Comparison

The following table provides modified details for spandrel beams and steel plates in colored boxes. The information presented in the blank boxes is the same as the original design, as shown in Table 5-12.

Table 5-12: Summarized modification details of Case 3 by GSA and UFC requirements

	Elements			Story		
				1	2	3-8
GSA	Spandrel Beams	Longitudinal Reinforcements	Bot	2-#8, 2-#6	4-#6 Bars	
			Top	4-#6 Bars		2-#6 Bars
		Transverse Bars	#4 bars @ 12in with 2-leg			
	Steel Plates	Depth of Plates Strength of Material	d=8in, $f_{yt} = 36\text{ksi}$			
UFC	Spandrel Beams	Longitudinal Reinforcements	Bot	4-#10 Bars	4-#6 Bars	
			Top	4-#6 Bars		2-#6 Bars
		Transverse Bars	2-#5 bars @ 12in		2-#4 bars @ 12in	
	Steel Plates	Depth of Plates Strength of Material	d=10in, $f_{yt} = 36\text{ksi}$	d=8in, $f_{yt} = 36\text{ksi}$		

5.5. Comparison of Three Models

5.5.1 Comparison of Numbers of Stories about Elements Modification

Table 5-13 summarizes the modification stories of exterior spandrels in each case under GSA and UFC requirements. Through the table, in consideration with GSA, no modifications are required for spandrel embedment plates and spandrel shear strength in all three cases. For spandrel flexural strength, modifications are only needed in case 3. In comparison with GSA, UFC requires more modifications for spandrel embedment plates, shear strength and flexural strength. Even in case 2, modifications are required through almost the whole stories for spandrel embedment plates and spandrel flexural strength. In summary, more elements are

needed to be modified under the requirements of UFC than GSA. Therefore, the UFC criterion provides a more conservative modification than GSA does.

Table 5-13: Comparison of design modifications using GSA and UFC requirements

Case	Spandrel Embedment Plates		Spandrel shear strength		Spandrel flexure strength			
					Positive		Negative	
	GSA	UFC	GSA	UFC	GSA	UFC	GSA	UFC
Case1	No	Story1	No	Story1-2	No	Story1	Story1-2	Story1-2
Case2	No	Story2-6	No	Story2	No	Story1-7	Story1	Story1-6
Case3	No	Story1	No	Story1-2	Story1	Story1	Story1-2	Story1-2

5.5.2 Comparison of Deflections from Case 2 and Case 3

Using steel plates as connection to resist moment due to progressive collapse, is not possible in real case, especially at the portion directly above the removed column. Although the steel plates can provide adequate moment resistance, more anchorage bars are required to resist the tension transferred from steel plates. In Case 1, the ultimate tensile strength provided by 3-#9 bars is $1.25 \times 3 \times 1.0\text{in}^2 \times 65\text{ksi} = 243.75\text{kip}$ for GSA case, and $0.9 \times 3 \times 1.0\text{in}^2 \times 65\text{ksi} = 175.5\text{kip}$ for UFC case, if $f_y = 50\text{ksi}$, $f_u = 65\text{ksi}$. See details in Figure 5-23. However, the demand tensile resistances due to moments at connections above the removed column are 389 kip for both cases. Apparently, the expected ultimate tensile capacities of anchorage bars are much smaller than the demand. In real case, the ultimate tensile resistance provided by strands is about 200 kip to 300 kip. Additionally, no more bars can be connected to the steel plates due to the limited steel plate depth. Accordingly, the connections in Case 1 are more likely to failed due to brittle of anchorage bars, even the strength of steel plates is adequate.

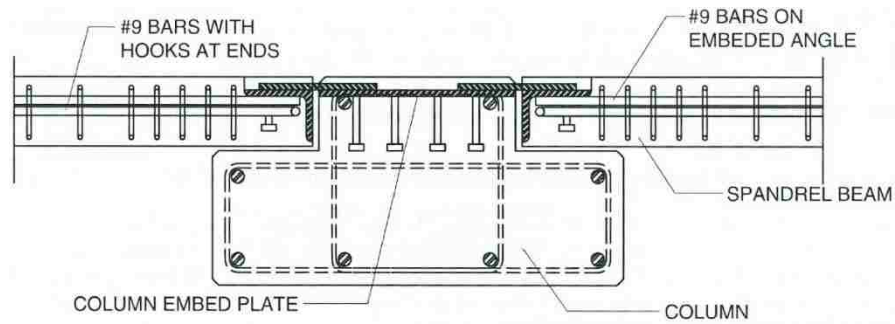

Figure 5-23: Spandrel-to-column connection (PCI, 2007)

By contrast, modifications based on Case 2 and Case 3 are more applicable in practice. Conservatively, the beams at connections are modeled as simply-supported. Under such conditions, in Case 2 the required negative moment acted at the fixed end of the cantilever beam reaches 18870 kip-ft, which needs further redesign to satisfy the demand, as shown in Figure 5-24. The similar condition also exists in Case 3, the required positive moment capacity is 17185 kip-ft, as shown in Figure 5-25. The detailed redesigns are not included in this report.

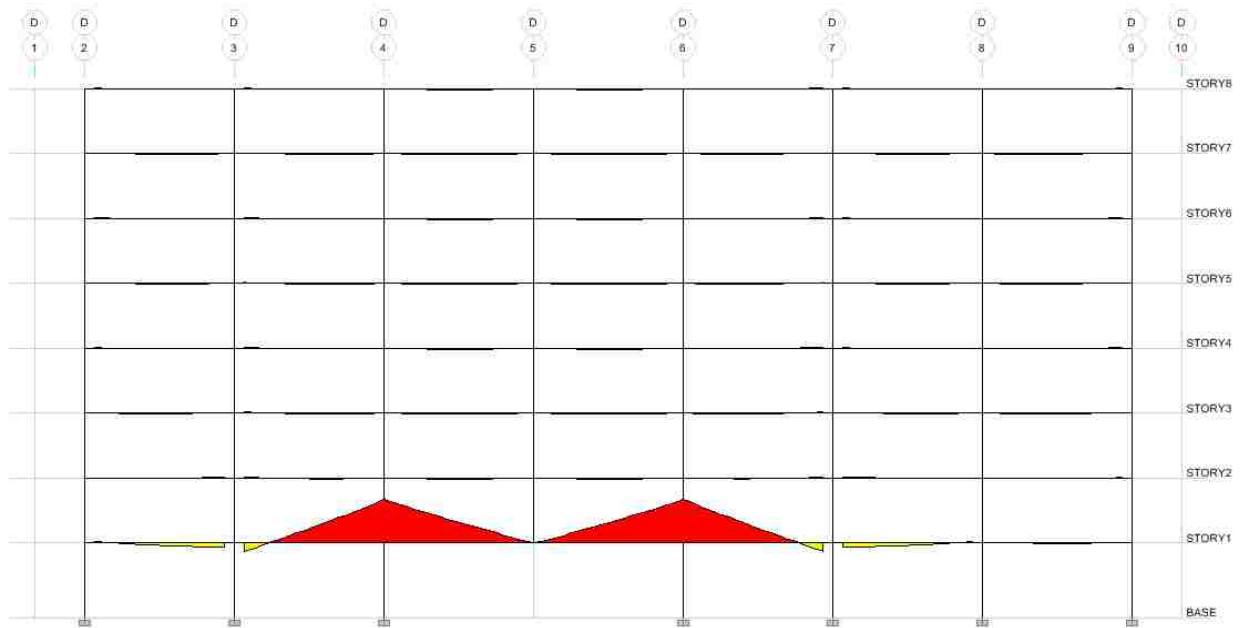

Figure 5-24: Moment distribution of Case 2 if all pinned connections form in ETABS

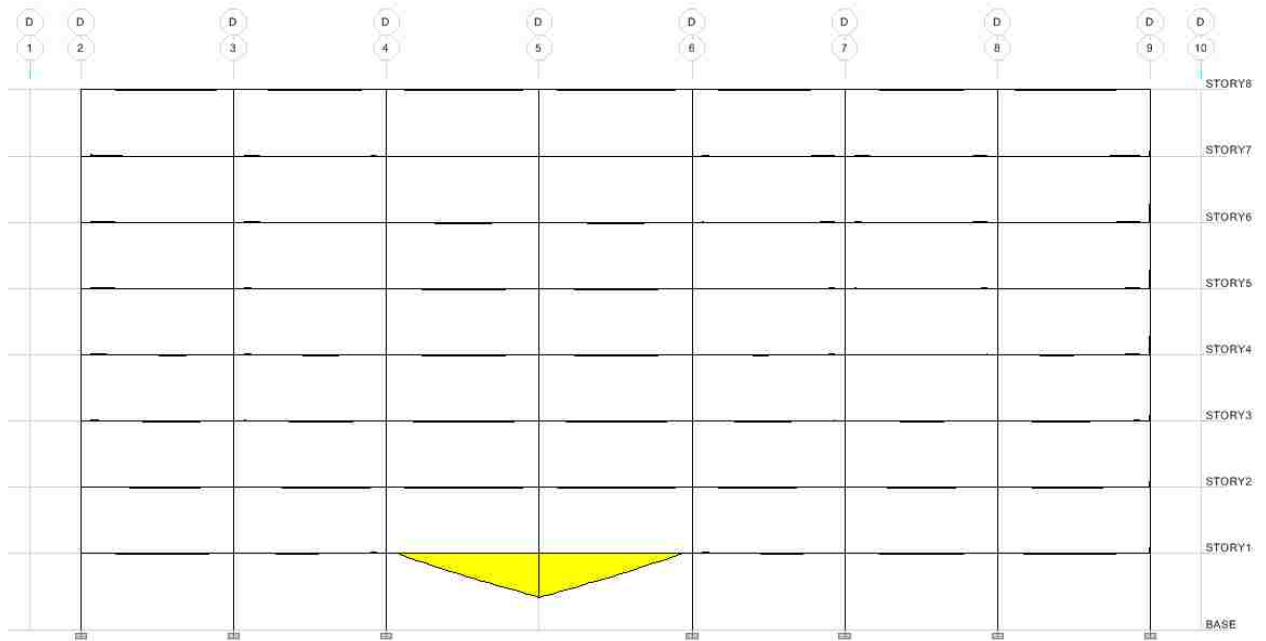

Figure 5-25: Moment distribution of Case 3 if all pinned connections form in ETABS

In the following discussion of this report, upper level connections above Story-1 are assumed to provide adequate strength against failure. The continuous spandrel beams are considered with modification so that no beam failure occurs due to progressive collapse. Therefore, the component's deflection directly above the removed column is checked to determine which modified case is better. Only GSA criterion is considered in the following sections.

5.5.2.1 Load-Deflection Relationships of Case2: Modified Model with Cantilever Beams

In this case, two single spandrel beams are replaced by one continuous beam. Since the connections formed of the steel plates at the ends of the continuous beams are relatively weak they fail to provide sufficient moment capacity. The continuous beam is modeled as a cantilever beam with no moment resistance at its free end. It is conservative to simulate in this way.

Based on GSA requirement, 2-#8 and 2-#6 longitudinal bars are placed at the top of the spandrel beam, as shown in Figure 5-26, so that the negative moment capacity at yielding is increased to 1550 kip-ft, and the ultimate capacity is 2018 kip-ft. The curvatures at yielding and failure are 0.000067 per inch and 0.0009 per inch, respectively.

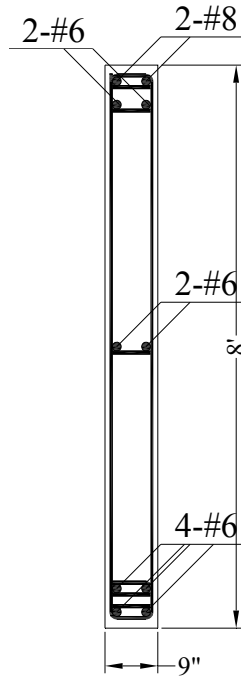

Figure 5-26: Modified spandrel beam cross-section in Case 2

5.5.2.1.1 Vertical Concentrated Load-Deflection Relationship

The yield and ultimate deflections are evaluated by quadratic integral of the curvature at yield and ultimate moment. To evaluate of the yield deflection at the free end, first determine the curvature equation. The curvature with yielding value acts at the fixed end of the cantilever beam, and zero curvature value is at the points where load applied. So curvature along the beam develops linearly and its equation can be easily determined, as shown in Figure 5-28. However, for the ultimate deflection, firstly the location of yield moment is determined based on the assumption that the fixed-end reaches the ultimate moment capacity.

Then the yield curvature occurs at the place of yielding moment and the curvature-distance equation is determined. The ultimate condition is illustrated in Figure 5-28. The deflection is determined by $d_p = \int_0^{X_p} \Phi(x) dx$. From Figure 5-27 below, the end deflection d_e is equal to the deflection d_p (at a distance X_p from the face of the support to the load applied place) plus the product of the rotation and the distance from the face of load applied to the end of the beam, namely, $(L - X_p) \times r$.

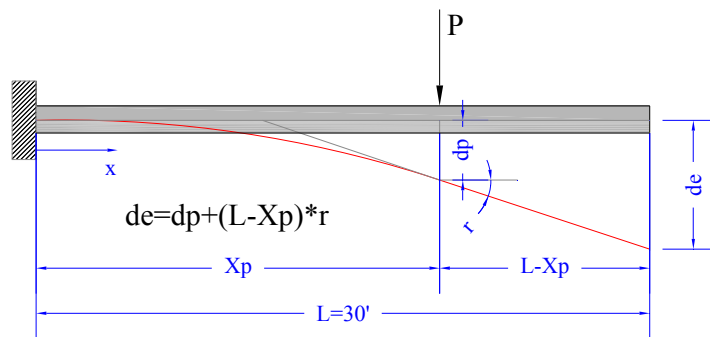

Figure 5-27: Vertical concentrated load applied on the cantilever beam

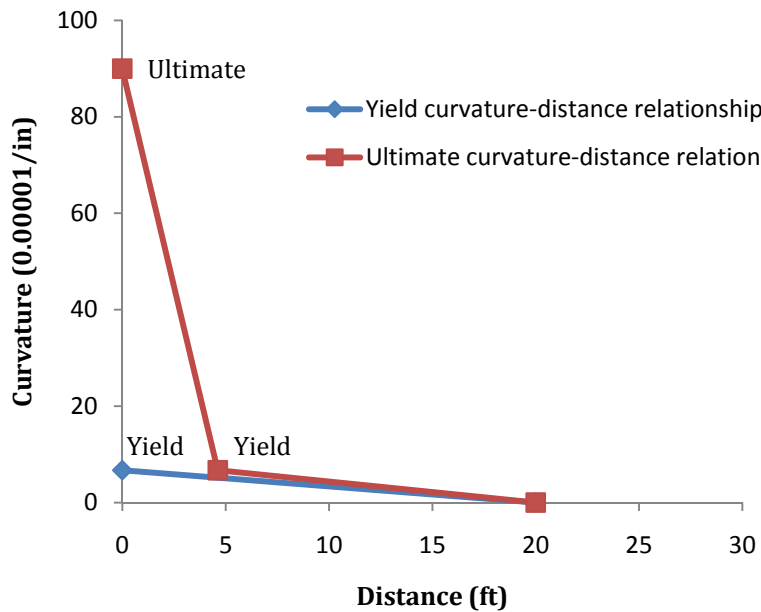

Figure 5-28: Yield and ultimate curvature-distance relationship by concentrated load for cantilever beam

Accordingly, the Load-Deflection Relationships can be determined at different locations where load applies as follows. The transition of moment to concentrated load is $P = M/X_p$, so that the loads of yield and ultimate can be determined directly based on yield moment and ultimate moment. When the load is applied at the end of the spandrel beam, the end deflections at yielding and ultimate are 2.7 in and 15 in, respectively. For other cases, the concentrated loads are located at distances of 2.5 ft, 7.5 ft, 12.5 ft, 17.5 ft, 22.5 ft and 27.5 ft from the center of the beam-to-column connection, due to the effects of secondary beams which are models as ribs of the double tee slabs, as shown in Figure 5-30. Through Figure 5-29, end deflections can be determined readily if the concentrated loads are available. Since the loads transferred from the secondary beams are approximately equal to 38 kip, the total end deflection is the sum of deflections due to each beam vertical load.

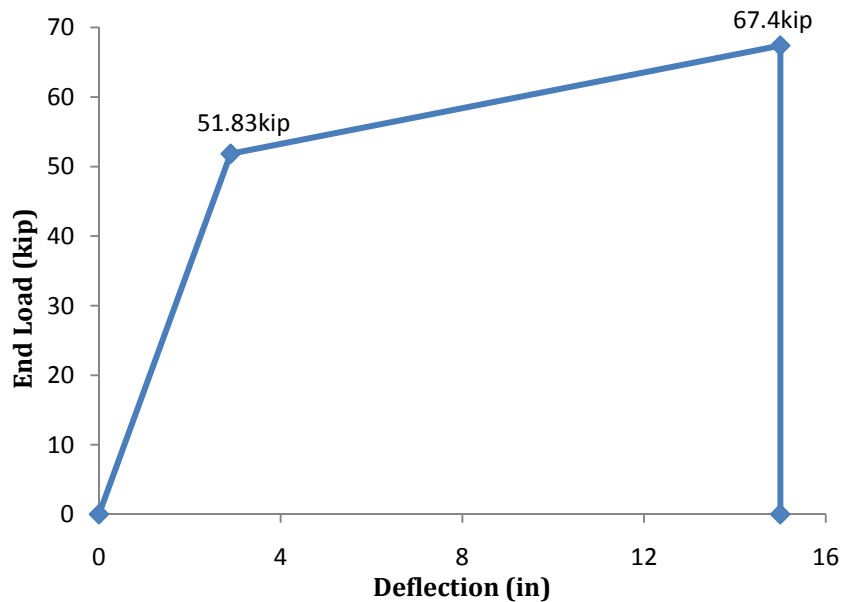

Figure 5-29: End load-deflection relationship of Case 2 by GSA requirements

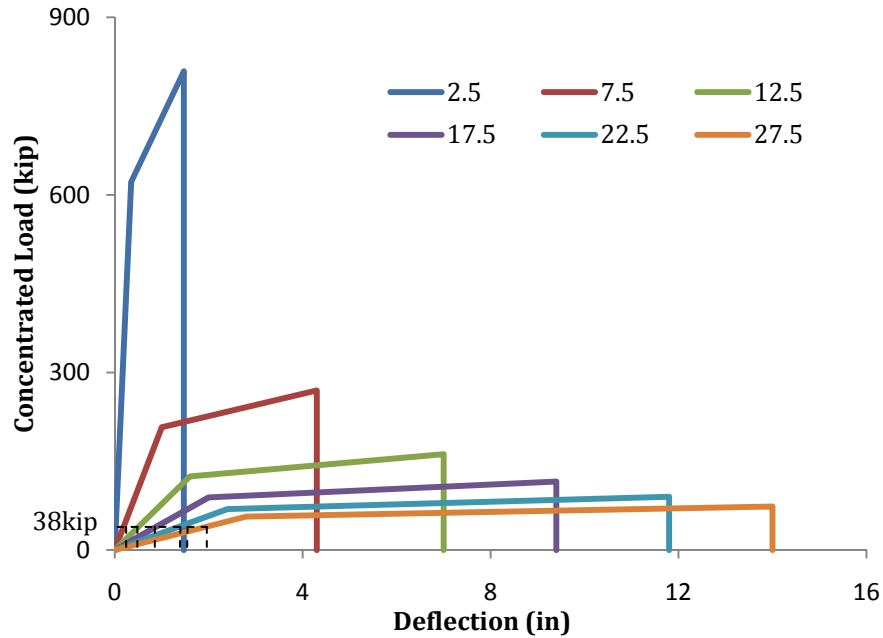

Figure 5-30: Concentrated load-deflection relationship of Case 2 by GSA requirements

Based on Figure 5-30, when the concentrated loads, except the end load, are 38 kip, the end deflection due to each secondary beam effect is read as follows:

For the load applied at 2.5 ft: $\Delta_{2.5} = 0.02$ in

For the load applied at 7.5 ft: $\Delta_{7.5} = 0.2$ in

For the load applied at 12.5 ft: $\Delta_{12.5} = 0.5$ in

For the load applied at 17.5 ft: $\Delta_{17.5} = 0.8$ in

For the load applied at 22.5 ft: $\Delta_{22.5} = 1.3$ in

For the load applied at 27.5 ft: $\Delta_{27.5} = 1.9$ in

Thus, the sum of these loads is $\Delta_{\text{tot_con}} = \sum \Delta = 4.72$ in

5.5.2.1.2 Uniformly Distributed Load-Deflection Relationship

In the same way as concentrated load applied on the cantilever beam, the Load-Deflection Relationship can also be determined by quadratic integral of curvature, see in Figure 5-31. Even though the moment curve due to distributed load is developing non-linearly, the curvature is assumed to display linearly, because the difference between linear results and non-linear results can be neglected. The curvatures respect to the yield condition and ultimate condition are illustrated in Figure 5-32.

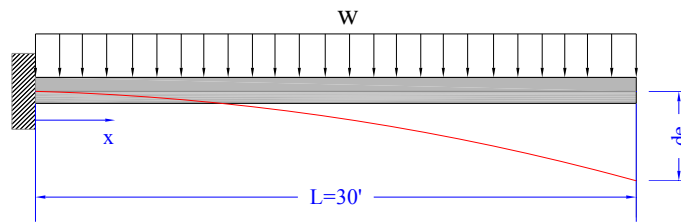

Figure 5-31: Distributed load applied on the cantilever beam

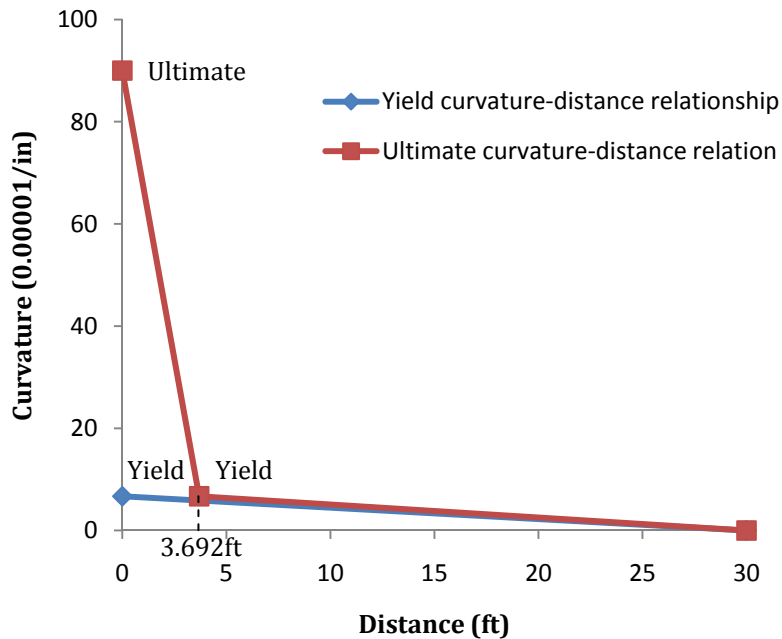

Figure 5-32: Yield and ultimate curvature-distance relationship by distributed load for cantilever beam

The transition of fixed-end moment to uniformly distributed load is applied as $W = 2 \times M/L^2$, so that the loads applied at yield and ultimate situations can be determined directly based on yield moment and ultimate moment. Similarly, the distributed load-deflection relationship is determined as shown in Figure 5-33:

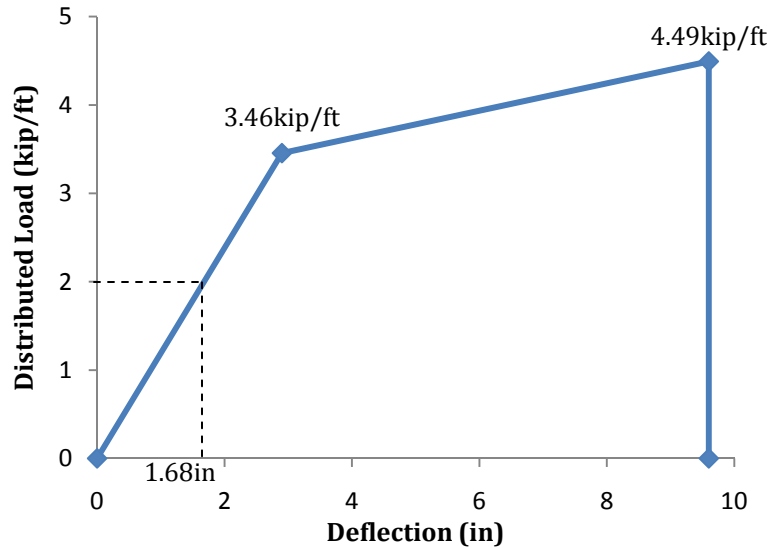

Figure 5-33: Distributed load-deflection relationship of Case 2 by GSA requirements

The uniformly distributed load mainly results from the cantilever beams, and its value is about 2 kip/ft. Accordingly, the end deflection due to the distributed load read from the figure above is 1.68 in.

5.5.2.2 *Load-Deflection Relationships of Case3: Modified Model with Simply-supported Beams*

In this case the steel plates of connections in Line D-4 and Line D-6 of Story-1 fail, thus no moment resistance is provided, and the double-length continuous beam in modeling is modified as simply supported rather than fixed-fixed beams. Simulation in this way leads to a more conservative result.

Based on GSA requirement, in Figure 5-34, 4-#6 longitudinal bars are placed at the top, 2-#8 and 2-#6 bars are placed at the bottom of the spandrel beam, so that the negative yielding moment capacity is increased to 1550 kip-ft, and the ultimate capacity is 2018 kip-ft. The curvatures at yielding and failure are 0.000067 per inch and 0.0009 per inch, respectively. The cross-section of Case 3 is inversion of Case 2, so the cost of the beams in two cases is the same, through which the comparison of two cases is developing under the same condition. As discussed in Case 2, the deflections are determined by quadratic integral of the curvatures.

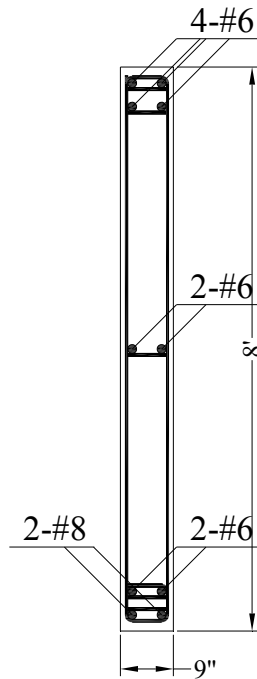

Figure 5-34: Modified spandrel beam cross-section in Case 3

5.5.2.2.1 Vertical Concentrated Load-Deflection Relationship

Since the length of the continuous beam is 60 ft, the curvature equation is based on the whole length. As shown in Figure 5-35, the curvature-distance histories in yield point and ultimate point are used to determine the mid-span deflection. The transition of moment to concentrated load is applied as $P = 2 \times M/X_p$, so that the loads applied at yield and ultimate

situations can be determined directly based on yield moment and ultimate moment. The curvatures respect to the yield condition and ultimate condition are illustrated in Figure 5-36.

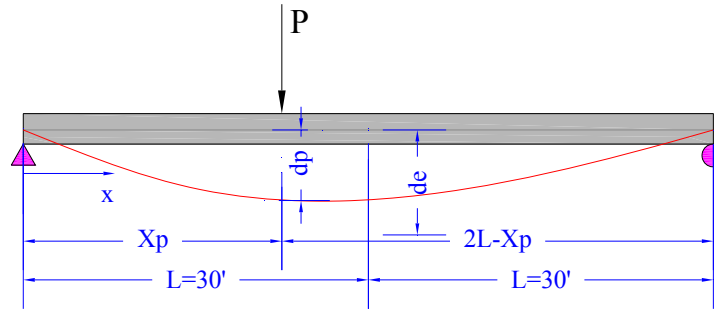

Figure 5-35: Vertical concentrated load applied on the simply-supported beam in Case 3

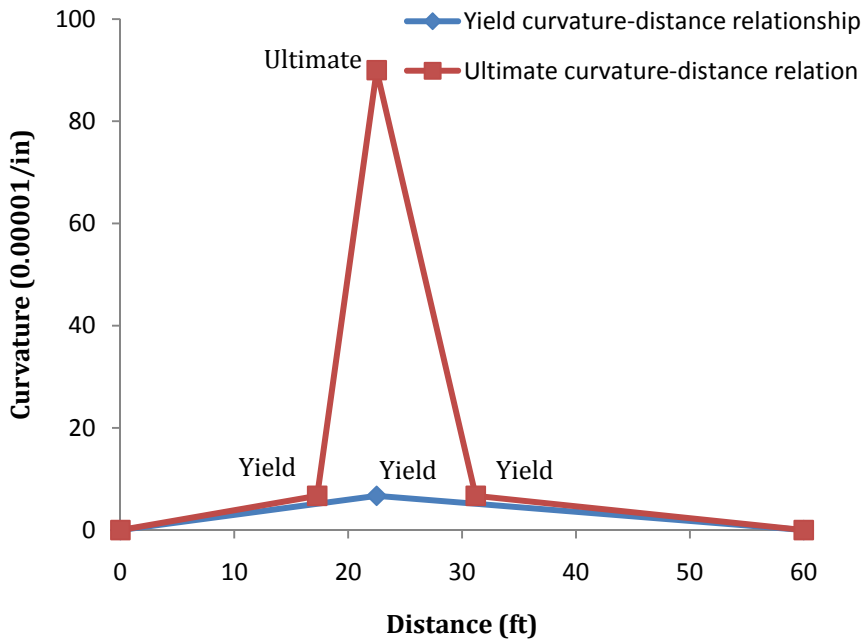

Figure 5-36: Yield and ultimate curvature-distance relationship by concentrated load for simply-supported beam

Accordingly, the Load-Deflection Relationships can be determined at different locations of load applies as follows. For the load applied at the mid-span of the simply-supported beam, the mid-span deflection at yield point and ultimate point are 2.9 in and 5.7 in, respectively. For other cases, the concentrated loads are located at distances of 2.5 ft, 7.5 ft, 12.5 ft, 17.5 ft,

22.5 ft and 27.5 ft from the center of the beam-to-column connection within each 30ft due to secondary beams. Thus, only half span effects in mid-span deflection is considered, and the total mid-span deflection is equal to double deflection of half span effects. Through Figure 5-38, mid-span deflections can be determined readily if the concentrated loads are available. Same as Case 2, the loads transferred from the secondary beams are approximately equal to 38 kip.

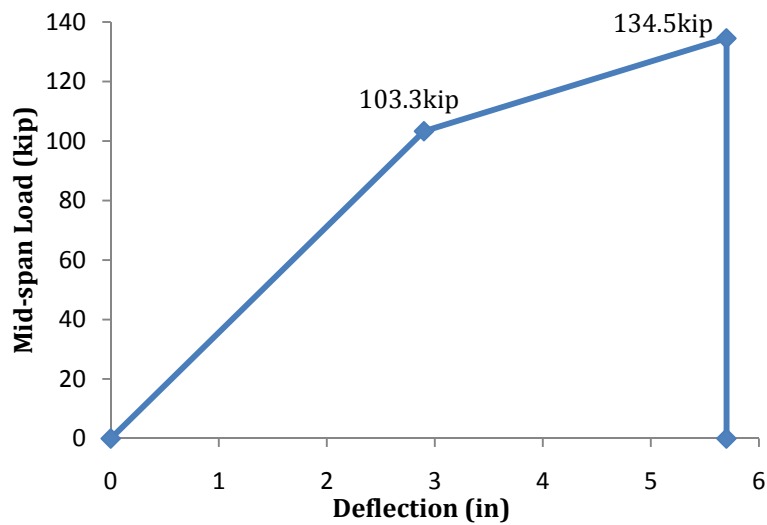

Figure 5-37: End load-deflection relationship of Case 3 by GSA requirements

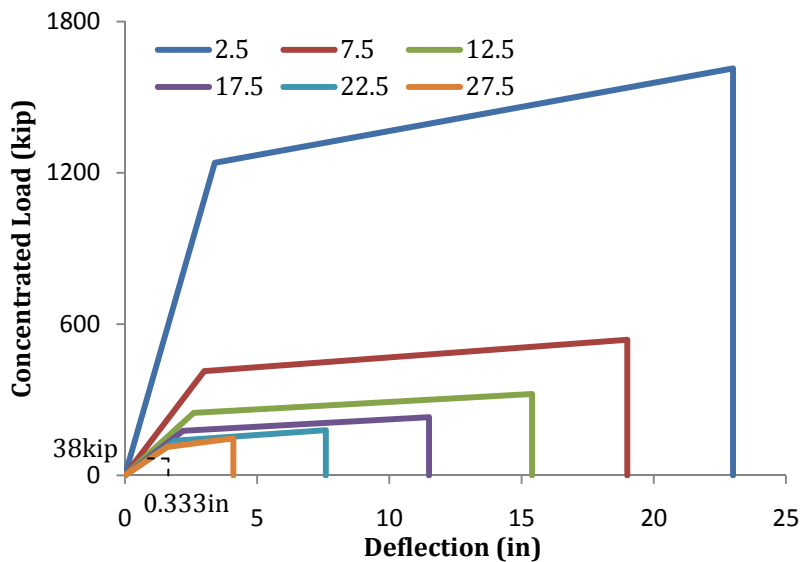

Figure 5-38: Concentrated load-deflection relationship of Case 3 by GSA requirements

Based on Figure 5-37, when the concentrated loads, except the end load, are 38 kip, the averaged mid-span deflection due to 6 secondary beams is about 0.333 in for half span, so that the total mid-span deflection due to vertical loads on the whole span, except the mid-span load, is

$$\Delta_{\text{tot_con}} = \Delta \times 6 \times 2 = 4 \text{ in}$$

5.5.2.2.2 Uniformly Distributed Load-Deflection Relationship

The transition of mid-span moment to uniformly distributed load is applied as $W = 2 \times M/L^2$, so that the loads applied at yield and ultimate situations can be determined directly based on yield moment and ultimate moment. In the same way as concentrated load applied on the cantilever beam, the Load-Deflection Relationship can also be determined by quadratic integral of curvature. Even though the moment curve due to distributed load is developing non-linearly, the curvature is assumed to display linearly, because the difference between linear results and non-linear results can be neglected. The moment and curvature is symmetrical every 30 ft, calculation of entire span load effects is time-consuming and unnecessary, so detailed calculation of half span effects is presented. Figure 5-39 provides an image of condition of distributed load applied on the simply-supported beam.

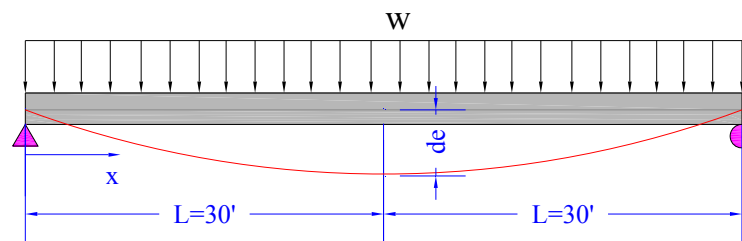

Figure 5-39: Distributed load applied on the simply-supported beam in Case 3

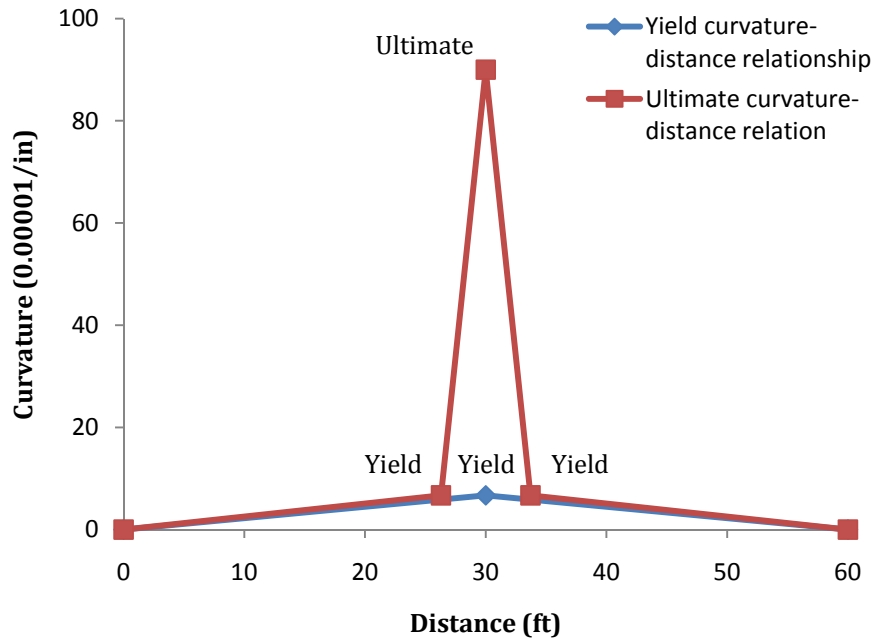

Figure 5-40: Yield curvature-distance relationship by distributed load for simply-supported beam

By integral of curvature in Figure 5-40, the mid-span deflections due to distributed load along the whole span at yield and ultimate conditions are 2.9 in and 3.8 in, respectively.

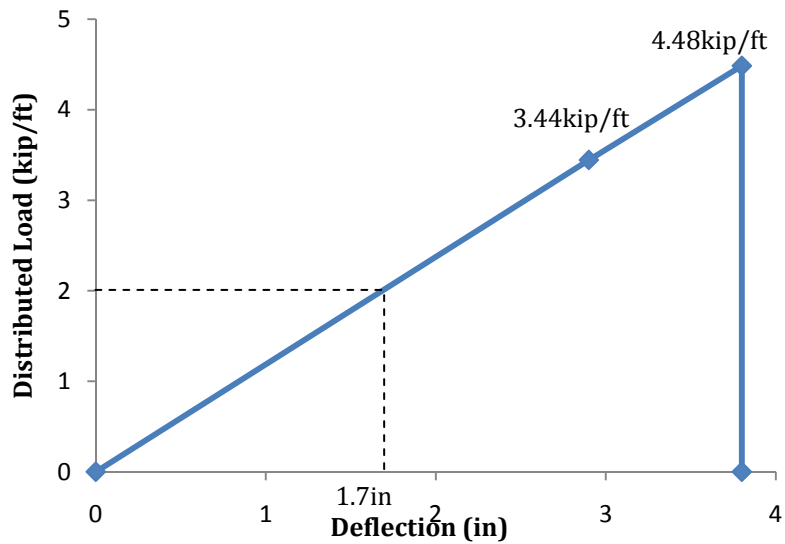

Figure 5-41: Distributed load-deflection relationship of Case 3 by GSA requirements

The uniformly distributed load mainly results from the cantilever beams, and its value is about 2 kip/ft as shown in Figure 5-41. Accordingly, the mid deflection due to the distributed load read from the figure above is 1.7 in, which is almost the same as Case 2.

5.5.2.3 Comparison of Vertical Load Applied at the Continuous Beams Directly above the Removed Column

Basically, the upper level structures above Story-1 are totally the same for Case 2 and Case 3, the vertical loads, transferred from the upper level to Story-1 along Line D-5 are the same for both cases. In Case 2 two continuous beams are pinned connected at the location where the vertical load is applied, half of that load is acted for each continuous beam. However, in Case 3 the simply-supported beam is designed to support the total load. Therefore, the load applied at the end of the cantilever beam will always be half of the load applied at the mid-span of the simply-supported beam.

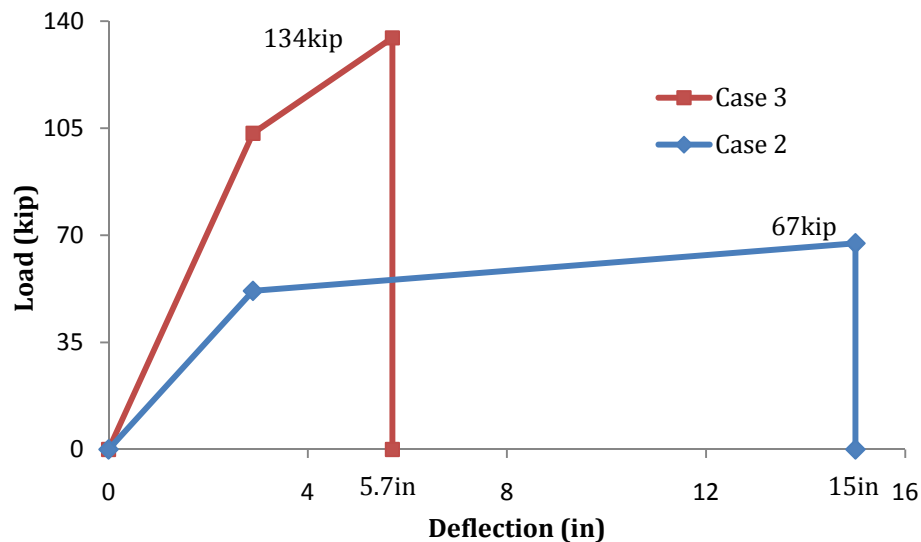

Figure 5-42: Comparison of direct load-deflection relationship in Case 2 and Case 3

Consequently, it is applicable to consider the ultimate situation in determination of the deflection. From the analysis above, the ultimate load applied in Case 3 is 134 kip, in other

words, the load acted in Case 2 also reaches its ultimate value 67 kip. In Case 3, the corresponding mid-span deflection is only 5.7 in, but for Case 2, the end-deflection at the same location is going to 15 in. The details about load-deflection relationship in Case 2 and Case 3 are illustrated in Figure 5-42.

5.5.2.4 Conclusions

All the deflections of three types of loads are concluded in Table 5-14:

Table 5-14: Summary of deflections in Case 2 and Case 3

Load Types	Deflections in Line D-5 (in)	
	Case 2	Case 3
Concentrated Load due to Secondary Beams	4.72 in	4 in
Uniformly Distributed Load	1.68 in	1.7 in
Direct Vertical Load	15 in	5.7 in
TOTAL	21.4 in	11.4 in

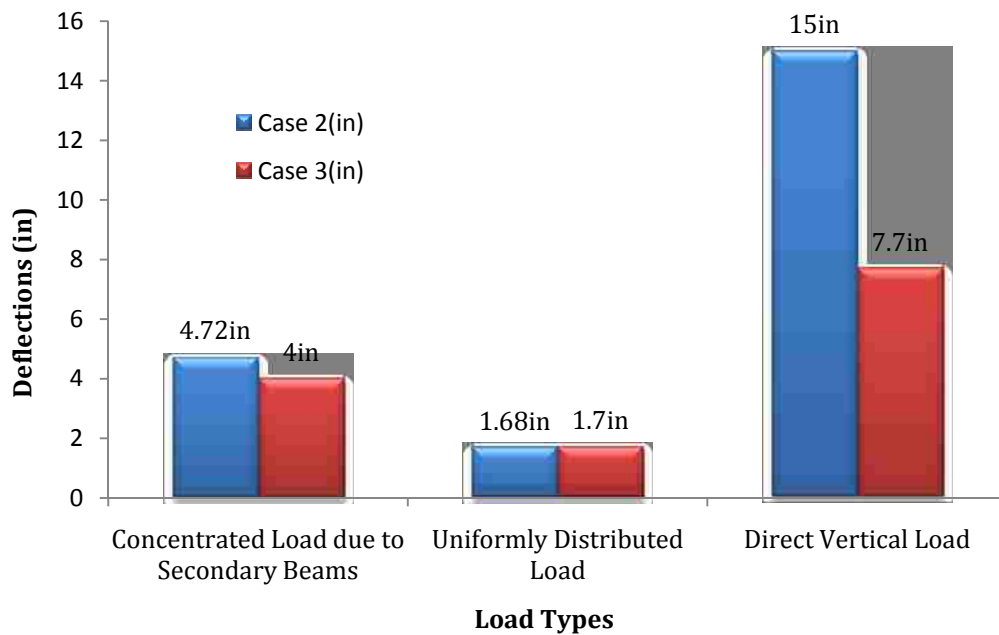

Figure 5-43: Summary of deflections in Case 2 and Case 3

Based on Figure 5-43, the ultimate deflection in Case 3 is approximated as 60 percent of that in Case 2. Since the dimensions, reinforcements and costs are the same for both cases, apparently, Case 3 makes more efforts in deflection reduction than Case 2 does.

5.6. Limitations of Progressive Collapse Evaluation

The progressive collapse evaluation was conducted in a simplified manner. Assumptions were made that localized failure of the spandrel imbeds would not occur and that they would be able to reach their ultimate strength without being compromised prematurely. Recent research by the National Institute of Standards and Technology indicated that premature failure of the embed plates may occur due to prying as the spandrel undergoes large deformations. To address this concern further detailed finite element analysis should be conducted in the future to assess the accuracy of the simplified methods conducted here.

6. CONCLUSIONS

In this report, threat evaluations due to bombing and progressive collapse of a precast concrete building system is examined and presented. A prototype structure based on the moment frame building system from PCI-Seismic Design for Precast/Prestressed Concrete Structures is used for these evaluations. Two distinct studies are conducted. The first examines the potential for abrupt failure of the ground level columns due to intentional detonation of explosives; the second examines the potential for progressive collapse of the building system as a result of this loss. Three types of column failures, including brisance failure, flexural failure, and direct shear failure are discussed and evaluated based on blast load effects.

Comparison of three types of column failures indicates that the columns are most likely to suffer flexural failure, since the safe-range distance of flexural failure is required to be greater than that of brisance failure and direct shear failure in order to keep the structure safe. For a given explosive weight the column will fail in flexure at the furthest standoff followed by direct shear and brisance at reduced standoff distances. In all cases the assumption is made that the in-fill walls on the first floor are adequately attached to the columns to ensure transfer of the blast pressures to the column. If an open first floor is used or light detachable walls are part of the first floor then flexure failure will be unlikely due to the small surface area of the column. In that case direct shear and brisance make up the primary failure cases.

A pictorial representation of the stand-off distances and number of failed columns are provided to assess the combined effects of blast load types with a specified charge weight. The stand-off failure zones are developed for various charge weights using the methods of UFC-3-340-02. The generalized image provides a safe-range for each failure type. This

failure zone illustration could be used in the initial site layout to guide engineers and owners in making appropriate choices for on a safe standoff condition for the facility. For existing facilities it can be used to make decisions on armoring strategies for exterior building columns.

The UFC and GSA consist of a design option which removes one column from the structure to assess progressive collapse resistance. Based on the results of the study, this approach may be unconservative. The failure analyses conducted on the PCI prototype building revealed that failure of multiple columns is likely due to column failure from flexural overload, direct shear, and the shattering effects under brisance. For higher quantities of explosive (~5000 lbs TNT) it is possible that up to four exterior columns can be lost simultaneously if a protective standoffs of less than 55ft is provided. Cases of two to three column failures are also possible due to direct shear and brisance at lower standoff levels with lower quantities of explosive. If however a standoff of 80 ft is maintained for the facility the evaluation shows that the columns would be safe under typical explosive demand sizes. The results of the study indicate that under reduced standoffs a multiple column loss scenario should be adopted for the progressive collapse procedure for the facility.

In progressive collapse analysis section, the structure is examined using the procedures of the Unified Facilities Criteria (UFC) and the General Services Administration (GSA). Three model cases are compared: original model, modified model with cantilever continuous beam, and modified model with fixed-fixed continuous beam, analyze progressive collapse responses and make modifications by employing linear static procedure. The current GSA progressive collapse guidelines and UFC progressive collapse design are used for evaluations,

and the commercially available structural analysis program ETABS Nonlinear V9.7.1 is utilized to perform example analyses.

The evaluations show that UFC provides more conservative requirements in progressive collapse resistance than GSA does. Additionally, the deflections directly above the removed column are evaluated in the modified models with adequate strength, since the original model shows insufficient progressive collapse resistance due to inadequate strength of steel plates and anchorage bars.

In progressive collapse analyses section, the connection of the spandrels to the columns (i.e., steel plates and anchorage bars) are not reliable under column loss, especially around the location where the column is removed directly, even though these elements provide adequate performance under seismic demands. To provide enhanced reliability to the system the spandrel length is increased to two spans. Under this condition loss of a column would result in the spandrel providing support through flexural action. Loss of a column at the end of the two-span spandrel would result in negative flexural support of the upper level columns while midspan loss would result in positive flexural support of the upper floors. Both the continuous cantilever beam and continuous simply-supported beam methods of support perform well above the removed column in progressive collapse resistance, since the large moment and tension are carried by reinforcement in beams instead of anchorage bars and steel plates.

To fully assess the resistance to progressive collapse enhanced nonlinear finite element analysis of the system should be conducted. The results of this effort may indicate the need for enhanced connection detailing to ensure integrity of the spandrel under column loss.

7. REFERENCE

ACI 318-08, *Building Code Requirements for Structural Concrete and Commentary*. American Concrete Institute, 2008.

ASCE 7-10, *Minimum Design Loads for Buildings and Other Structures*. American Society of Civil Engineers, 2010.

Cynthia, R. G., “Breaking the Circle: Educating Undergraduates through Failure Case Studies,” 2002, <http://matdl.org/failurecases/final.pdf>

GSA, *Progressive Collapse Analysis and Design for New Federal Buildings and Major Modernization Projects*. General Service Administration, 2003.

PCI, *PCI Design Handbook*, 7th Ed.. Precast / Prestressed Concrete Institute, 2010.

PCI, *Seismic Design of Precast/Prestressed Concrete Structures*. Precast / Prestressed Concrete Institute, 2007.

UFC-4-023-03, *United Facilities Criteria, Design of Buildings to Progressive Collapse*. Department of Defense, 2010.

UFC-3-340-02, *United Facilities Criteria, Structures to Resist the Effects of Accidental Explosions*. Department of Defense, 2008.

Robert Smilowitz, “Means for Risk Reduction and Analytical Approaches,” http://www.bfrl.nist.gov/861/861pubs/collapse/workshop/3.Smilowitz_2MU.pdf

Lew, H. S., “Workshop on Best Practice for Reducing Potential for Progressive Collapse in Buildings,” [http://www.bfrl.nist.gov/861/861pubs/collapse/workshop/1Lew\(Introduction\).pdf](http://www.bfrl.nist.gov/861/861pubs/collapse/workshop/1Lew(Introduction).pdf)

PCA, *Structural Integrity Requirements for Concrete Buildings*, Portland Cement Association,

2006, [http://www.nebrconcagg.com/assets/PromotionPages/Structural/structural%20\(7\).pdf](http://www.nebrconcagg.com/assets/PromotionPages/Structural/structural%20(7).pdf)

Paul, M. S., W, C. G., Mete, S. A., and Charles, T. H., “The Oklahoma City Bombing: Analysis of Blast Damage to the Murrah Building,” *Journal of Performance of Constructed Facilities*, Volume.12, Issue.3, August, 1998, page.113-119.

Nuan, J., “Precast Concrete: Formidably Formed,” *Servicemagic Home Improvement Articals*, 2010, <http://www.servicemagic.com/article.show.Precast-Concrete-Formidably-Formed.15096.html>

Lain, A. Macleod., “Supplementary Information on Modeling: Photograph of the Ronan Point building after the collapse in 1968,” *Modern Structural Analysis-Modeling Process and Guidance*, ICE Publishing (UK), 2005, http://imacleod.com/msa/supllinfo_ch2_photo.php

example by ETABS, as a conclusion the more reasonable method in UFC and ACI is determined by GSA.

Internship in China Urban Construction Design & Research Institute, Beijing, China, June 2010-Aug 2010

By utilizing structural design software PKPM and AutoCAD, cooperated in structural design and completed structural drawings of Beijing Jinsong Tangbei Mass Organization Building, independently designed and finished construction drawings of No.2 building of Tangshan Ming&Qing Dynasty Business Street. Obtained an Excellent Internship Certification

Internship in Construction Site of Tairanju Residential District, Taiyuan, China, July 2008-Aug 2008

As an assistant supervisor, checked conditions of walls' cracks, supervised process of pavement of road successfully in the construction site of Tairanju Residential District Construction Project

Study on Heat-Insulation Concrete, Taiyuan, China, April 2008-May 2008

As a member of research group, studied heat insulation capability of heat-preserved concrete and successfully reduced the heat conductivity to 85%, attaining the international advanced level

Publication

Integration Technology of Seismic Reinforcement and Energy Saving Reconstruction for Existing Building (Construction Technology 2009(5) Page45)

Leadership

Volunteer, Second Taiyuan Coal & New Energy Sources Industry Exposition, Taiyuan, China, Sept 2008

Led the reception of US and Canada delegate.

Activities

Member of American Society of Civil Engineering, Member of Fritz Engineering Research Society