

University of Windsor

## Scholarship at UWindor

---

Electronic Theses and Dissertations

Theses, Dissertations, and Major Papers

---

8-15-2019

# Investigation of Engine Coolant Loop Flow Modelling from a System Simulation Perspective

Elle Mistruzzi  
*University of Windsor*

Follow this and additional works at: <https://scholar.uwindsor.ca/etd>

---

### Recommended Citation

Mistruzzi, Elle, "Investigation of Engine Coolant Loop Flow Modelling from a System Simulation Perspective" (2019). *Electronic Theses and Dissertations*. 7822.  
<https://scholar.uwindsor.ca/etd/7822>

This online database contains the full-text of PhD dissertations and Masters' theses of University of Windsor students from 1954 forward. These documents are made available for personal study and research purposes only, in accordance with the Canadian Copyright Act and the Creative Commons license—CC BY-NC-ND (Attribution, Non-Commercial, No Derivative Works). Under this license, works must always be attributed to the copyright holder (original author), cannot be used for any commercial purposes, and may not be altered. Any other use would require the permission of the copyright holder. Students may inquire about withdrawing their dissertation and/or thesis from this database. For additional inquiries, please contact the repository administrator via email ([scholarship@uwindsor.ca](mailto:scholarship@uwindsor.ca)) or by telephone at 519-253-3000ext. 3208.

# **Investigation of Engine Coolant Loop Flow Modelling from a System Simulation Perspective**

By  
Elle Mistruzzi

A Thesis  
Submitted to the Faculty of Graduate Studies  
through the Department of Mechanical, Automotive & Materials Engineering  
in Partial Fulfillment of the Requirements for  
the Degree of Master of Applied Science  
at the University of Windsor

Windsor, Ontario, Canada

© 2019 Elle Mistruzzi

# Investigation of Engine Coolant Loop Flow Modelling from a System Simulation Perspective

By

Elle Mistruzzi

Approved by

---

S. Natarajan  
FCA Canada Inc.

---

R. Carriveau  
Department of Civil & Environmental Engineering

---

V. Roussinova  
Department of Mechanical, Automotive & Materials Engineering

---

R. Balachandar, Co-Advisor  
Department of Mechanical, Automotive & Materials Engineering

---

R. Barron, Co-Advisor  
Department of Mechanical, Automotive & Materials Engineering

August 15, 2019

## Declaration of Originality

I hereby certify that I am the sole author of this thesis and that no part of this thesis has been published or submitted for publication.

I certify that, to the best of my knowledge, my thesis does not infringe upon anyone's copyright nor violate any proprietary rights and that any ideas, techniques, quotations, or any other material from the work of other people included in my thesis, published or otherwise, are fully acknowledged in accordance with the standard referencing practices. Furthermore, to the extent that I have included copyrighted material that surpasses the bounds of fair dealing within the meaning of the Canada Copyright Act, I certify that I have obtained a written permission from the copyright owner(s) to include such material(s) in my thesis and have included copies of such copyright clearances to my appendix.

I declare that this is a true copy of my thesis, including any final revisions, as approved by my thesis committee and the Graduate Studies office, and that this thesis has not been submitted for a higher degree to any other University or Institution.

## Abstract

The engine cooling system in a vehicle ensures that the engine runs at its most efficient temperature under a variety of operating conditions. The system includes heat exchangers, a thermostat, pump, plumbing lines and a cooling water jacket. Each branch of the system and its different components need to receive adequate coolant flow. A system simulation (1D) model of the coolant loop is generated with components of the system individually characterized using geometry and/or performance data. Accurately modelling and capturing the flow behaviour of the coolant through the entire system, including the complex water jacket, poses a particular challenge. This thesis explores the use of experimental flow benches to support the research into converting a physical engine cooling system into a robust 1D system model. GT-SUITE software is used as the system simulation modelling platform, and its built-in application GEM3D is used to convert the 3D CAD geometry. A detailed investigation is performed by carefully splitting the plumbing and water jacket into multiple flow components. Non-dimensional pressure loss and Reynolds number are calculated based on pressure drop and flow rate data, for a wide range of temperatures including extreme cold conditions. Outcomes of this thesis include an in-depth and improved modelling process, well validated component and system level models, and an overall reduction in cost and time to achieve accurate results.

## Acknowledgements

I would like to thank my advisors from the University of Windsor, Dr. Ronald Barron & Dr. Ram Balachandar, for all of their support, patience and understanding over the past two years.

From FCA Canada I would like to thank Steve Simic & Kevin Studman for their support with my experimental work, Shankar Natarajan for his support with my simulation work, and Mohammed Malik & Marie Mills for being there whenever I needed help.

Finally, I could not have done any of this without the unconditional love and support of my husband Drew, and our adorable dogs Arlo & Otis.

# Table of Contents

Declaration of Originality .....	III
Abstract.....	IV
Acknowledgements.....	V
List of Figures.....	IX
List of Tables.....	XII
List of Symbols, Nomenclature and Abbreviations .....	XIII
<b>1. Introduction .....</b>	<b>1</b>
<b>1.1 Thesis Objectives.....</b>	<b>4</b>
<b>1.2 Thesis Organization .....</b>	<b>5</b>
<b>2. Literature Review .....</b>	<b>6</b>
<b>2.1 Engine Cooling .....</b>	<b>6</b>
<b>2.1.1 Design Process .....</b>	<b>6</b>
<b>2.1.2 System Breakdown.....</b>	<b>7</b>
<b>2.1.3 Literature Review of Previous Experimental Studies .....</b>	<b>13</b>
<b>2.2 System Simulation.....</b>	<b>16</b>
<b>2.2.1 System Design Principles .....</b>	<b>16</b>
<b>2.2.2 System Simulation Background.....</b>	<b>17</b>
<b>2.2.3 Governing Equations .....</b>	<b>18</b>
<b>2.2.3 Project Specific Equations.....</b>	<b>20</b>
<b>2.2.4 Literature Review of Previous Simulation Work .....</b>	<b>21</b>
<b>3. Experimental Flow Benches .....</b>	<b>24</b>
<b>3.1 Instrumentation .....</b>	<b>26</b>
<b>3.1.1 Pressure Sensors .....</b>	<b>26</b>
<b>3.1.2 Flow Meters.....</b>	<b>27</b>
<b>3.1.3 Thermocouples .....</b>	<b>27</b>
<b>3.1.4 Custom Fittings .....</b>	<b>28</b>
<b>3.2 Data Collection.....</b>	<b>29</b>
<b>3.2.1 Wiring and Connections .....</b>	<b>29</b>
<b>3.2.2 Data Programming Software.....</b>	<b>31</b>
<b>3.3 Single Component Flow Bench.....</b>	<b>32</b>
<b>3.3.1 Flow Schematic .....</b>	<b>33</b>
<b>3.3.2 Run Set Up .....</b>	<b>33</b>

3.3.3	Single Component Data Collection .....	34
3.4	System Level Flow Bench .....	36
3.4.1	Flow Schematic .....	36
3.4.2	Run Set Up .....	37
3.4.3	Detailed Engine Block Instrumentation .....	40
3.4.4	Hot Testing .....	43
3.4.5	Cold Testing .....	44
3.4.6	System Level Data Collection .....	45
4.	Component Level Investigation .....	47
4.1	Radiator and Heater Core .....	48
4.2	Engine Oil Cooler and Transmission Oil Heater .....	50
4.3	Exhaust Gas Recirculation Cooler .....	52
4.4	Hot Bottle .....	54
4.5	Water Pump.....	56
4.6	Component Summary.....	57
5.	System Level Investigation .....	58
5.1	Plumbing .....	59
5.2	Water Jacket Study.....	62
5.2.1	Water Jacket Data.....	62
5.2.2	Water Jacket Geometry.....	64
5.2.3	Water Jacket 1D Model .....	67
5.3	Thermostat .....	71
5.4	System Model Build .....	74
5.5	System Model Run Process .....	76
5.6	System Model Correlation .....	78
5.6.1	Flow Correlation .....	78
5.6.2	Friction and Pressure Drop Effects.....	81
5.6.3	Model Over Prediction.....	83
5.7	Limitations of System Simulation .....	87
6.	Conclusions .....	88
6.1	Summary .....	88
6.2	Conclusions.....	89
6.3	Future Recommendations .....	90



<b>References.....</b>	<b>91</b>
<b>Appendix A: Uncertainty Analysis.....</b>	<b>93</b>
<b>Appendix B: DOE Study .....</b>	<b>94</b>
<b>Vita Auctoris .....</b>	<b>96</b>

## List of Figures

Figure 1. 1 – Engine heat rejection breakdown [1].....	1
Figure 1. 2 – 1D Coolant loop example [2].....	3
Figure 2. 1 – Onset of flow instability in engine cooling system [4]. .....	7
Figure 2. 2 – Radiator exterior and internal geometry [6].....	8
Figure 2. 3 – General schematic for EGRc exhaust and coolant sides [8].....	9
Figure 2. 4 – Engine oil cooler showing coolant supply and return lines [9]. .....	9
Figure 2. 5 – Hot bottle internal coolant distribution [10]. .....	10
Figure 2. 6 – Pump coolant side with two scroll exits [11]. .....	11
Figure 2. 7 – Thermostat wax pellet valve system [1]. .....	11
Figure 2. 8 – Plumbing assembly example [14]. .....	12
Figure 2. 9 – Water jacket block, gasket holes and head [15]. .....	13
Figure 2. 10 – Example of instrumented engine cooling test bench [16]. .....	14
Figure 2. 11 – Automotive product design tree [4]. .....	16
Figure 2. 12 – Computational domain for system simulation set up [15]. .....	17
Figure 2. 13 – Data exchange between 1D network model and 3D CFD model [19]. .....	18
Figure 2. 14 – Schematic of staggered grid discretization [2].....	19
Figure 2. 15 – Simple 1D engine cooling model [20]. .....	23
Figure 3. 1 – Isometric view of engine cooling system flow bench. ....	24
Figure 3. 2 – Side view of engine cooling system flow bench.....	25
Figure 3. 3 – Pressure sensor, before and after bench installation. ....	26
Figure 3. 4 – Flow meter, front and cross-section views. ....	27
Figure 3. 5 – Thermocouple, before and after bench installation. ....	28
Figure 3. 6 – Custom fittings with variable diameter ends. ....	28
Figure 3. 7 – Bench mounted tachometer display and data logger.....	29
Figure 3. 8 – Laser tachometer aimed at water pump. ....	29
Figure 3. 9 – Bench mounted terminal blocks and flow transmitter. ....	30
Figure 3. 10 – Plumbing clamps, water tight grommet, and Amphenol mating connector. ....	30
Figure 3. 11 – Single component flow bench itemization.....	32
Figure 3. 12 – Single component flow bench schematic. ....	33
Figure 3. 13 – Single component flow bench reservoir and pump. ....	34
Figure 3. 14 – Heater core data collected on the single component flow bench.....	35
Figure 3. 15 – TOH data collected on the single component flow bench.....	35
Figure 3. 16 – System level flow bench itemization.....	36
Figure 3. 17 – System level flow bench schematic. ....	37
Figure 3. 18 – Engine and radiator mounting angle diagram. ....	38
Figure 3. 19 – 3D engine cooling system CAD compared to physical flow bench. ....	38
Figure 3. 20 – Motor, pulley and belt system used to drive the water pump. ....	39
Figure 3. 21 – Engine mounted thermostat compression tower.....	40

Figure 3. 22 – Cylinder block inlet CAD to bench instrumentation comparison.....	40
Figure 3. 23 – Cylinder block outlet CAD to bench instrumentation comparison. ....	41
Figure 3. 24 – Head outlet CAD to bench instrumentation comparison. ....	41
Figure 3. 25 – Pump outlet CAD to bench instrumentation comparison. ....	41
Figure 3. 26 – Bypass CAD to bench instrumentation comparison. ....	42
Figure 3. 27 – Thermostat housing CAD to bench instrumentation comparison. ....	42
Figure 3. 28 – Water jacket instrumentation cluster mounted on engine exterior. ....	43
Figure 3. 29 – Insulated system level bench chamber.....	43
Figure 3. 30 – Engine block cylinder bore heaters.....	44
Figure 3. 31 – Port holes on insulated chamber for cold testing.....	44
Figure 3. 32 – Remote conditioning unit fitted to insulated chamber. ....	45
Figure 3. 33 – EGRc data collected on the system level flow bench, closed thermostat. ....	46
Figure 3. 34 – Radiator data collected on the system level flow bench, open thermostat.....	46
Figure 4. 1 – 1D radiator component model.....	48
Figure 4. 2 – Dissected radiator and heater core for detailed geometry investigation. ....	49
Figure 4. 3 – Radiator component bench data to model correlation. ....	49
Figure 4. 4 – 1D TOH component model.....	50
Figure 4. 5 – Dissected TOH for detailed geometry investigation. ....	51
Figure 4. 6 – TOH component bench data to model correlation.....	51
Figure 4. 7 – 1D EGRc component model. ....	52
Figure 4. 8 – Dissected EGRc for detailed geometry investigation.....	53
Figure 4. 9 – EGRc component bench data to model correlation.....	53
Figure 4. 10 – 1D hot bottle component model. ....	54
Figure 4. 11 – Dissected bottle CAD for detailed geometry investigation.....	55
Figure 4. 12 – Hot bottle component bench data to model correlation. ....	55
Figure 4. 13 – 1D pump component model. ....	56
Figure 4. 14 – Pump component supplier data to model correlation. ....	57
Figure 5.1 – Cutting plane location diameter and bend angle. ....	60
Figure 5. 2 – Discretized coolant loop plumbing. ....	61
Figure 5. 3 – Discretized water jacket.....	62
Figure 5. 4 – Water jacket CFD result schematic. ....	63
Figure 5. 5 – Water jacket geometry with data locations.....	63
Figure 5. 6 – Flow split cutting plane. ....	64
Figure 5. 7 – Cylinder block flow splits.....	65
Figure 5. 8 – Port hole numbering in GEM3D.....	65
Figure 5. 9 – Gasket hole connection between block and head flow splits.....	66
Figure 5. 10 – Gasket hole numbering on head subassembly. ....	66
Figure 5. 11 – Gasket hole numbering on block subassembly.....	66
Figure 5. 12 – Head subassembly 1D model. ....	67
Figure 5. 13 – Block subassembly 1D model.....	67
Figure 5. 14 – Complete water jacket 1D model. ....	68

Figure 5. 15 – Left head 1D model correlation. ....	69
Figure 5. 16 – Gasket hole flow rate results. ....	70
Figure 5. 17 – Thermostat CFD result schematic. ....	71
Figure 5. 18 – 1D thermostat model. ....	73
Figure 5. 19 – Thermostat closed 1D model correlation. ....	73
Figure 5. 20 – 1D system level model, with flow component view. ....	75
Figure 5. 21 – 1D system level model, with pipe view. ....	75
Figure 5. 22 – Post processing temperature values, in degrees Celsius. ....	77
Figure 5. 23 – Post processing pressure values, in psi. ....	77
Figure 5. 24 – Heater core correlation within system level model. ....	79
Figure 5. 25 – TOH correlation within system level model. ....	79
Figure 5. 26 – System pressure drop at ambient condition based on thermostat position. ....	80
Figure 5. 27 - Reynolds number at locations throughout the engine cooling system. ....	82
Figure 5. 28 - Pressure drop points in the system model. ....	83
Figure 5. 29 - Virtual mass correction for pressure drop calculation. ....	84
Figure 5. 30 – Extreme cold component model correlation. ....	84
Figure 5. 31 – Extreme cold system model overprediction. ....	85
Figure 5. 32 – Extreme cold system model correlation. ....	86
Figure A. 1 – DOE parameter set-up and experiment number definition. ....	94
Figure A. 2 – Temperature parameter range. ....	94
Figure A. 3 – Result display selection for pressure drop across each heat exchanger. ....	95
Figure A. 4 – DOE study results for pressure drop across heat exchangers, at 1000 RPM pump speed. ....	95
Figure A. 5 – DOE study results for pressure drop across heat exchangers, at 2000 RPM pump speed. ....	95

# List of Tables

Table 2. 1 – Coolant freezing point by antifreeze percentage [5]. ..... 8

Table 4. 1 – Radiator/heater core model inputs..... 49

Table 4. 2 – Oil cooler/heater model inputs. .... 50

Table 4. 3 – EGRc model inputs. .... 53

Table 4. 4 – Hot bottle model inputs. .... 54

Table 5. 1 – List of coolant loop plumbing lines..... 59

Table 5. 2 – 3D to 1D conversion inputs. .... 60

Table 5. 3 – Thermostat vs. bypass lift values. .... 72

Table A. 1 – Uncertainty analysis calculations..... 93

## List of Symbols, Nomenclature and Abbreviations

<b>1D</b>	One-dimensional
<b>3D</b>	Three-dimensional
<b>A</b>	Amps
<b>AWG</b>	American wire gauge
<b>C</b>	Celsius
<b>CAD</b>	Computer aided design
<b>CFD</b>	Computational fluid dynamics
<b>DOE</b>	Design of experiments
<b>EGRc</b>	Exhaust gas recirculation cooler
<b>EOC</b>	Engine oil cooler
<b>GFM</b>	Global friction multiplier
<b>GPM</b>	Gallons per minute
<b>HVAC</b>	Heating, ventilation and air conditioning
<b>kPa</b>	Kilopascals
<b>LPM</b>	Litres per minute
<b>mm</b>	Millimeter
<b>NPT</b>	National pipe thread
<b>OFI</b>	Onset of flow instability
<b>PDM</b>	Pressure drop multiplier
<b>PID</b>	Proportional integral derivative
<b>psi</b>	Pounds per square inch
<b>Re</b>	Reynolds number
<b>RPM</b>	Revolutions per minute
<b>TOH</b>	Transmission oil heater
<b>V</b>	Volts
<b>VFD</b>	Variable frequency drive
<b>VTMS</b>	Vehicle thermal management system
<b>W</b>	Watts

# 1. Introduction

Since the conception of automobiles in the early 20<sup>th</sup> century, a number of advancements have been made in the field of internal combustion engines to improve overall vehicle performance and efficiency. Although many improvements have been made, these engines still lack the ability to harness all the chemical energy produced by fuel combustion into mechanical power needed to propel the vehicle. Some energy produced by the engine is dissipated as waste heat, and therefore an engine cooling system is critical for maintaining an optimum temperature. Figure 1.1 highlights an engine cooling loop with a typical breakdown for engine heat rejection post combustion, indicating coolant is responsible for absorbing 30% of the heat produced. Effective engine cooling ensures a vehicle reaches an efficient operating temperature as quickly as possible and works to maintain this temperature under a wide range of operating conditions and engine loads. At optimum engine operating temperature, the combustion chamber is adequately heated to vapourize fuel, to ensure that oil maintains a lower viscosity to move more freely (thereby wasting less power to move parts), and metal parts undergo reduced wear.

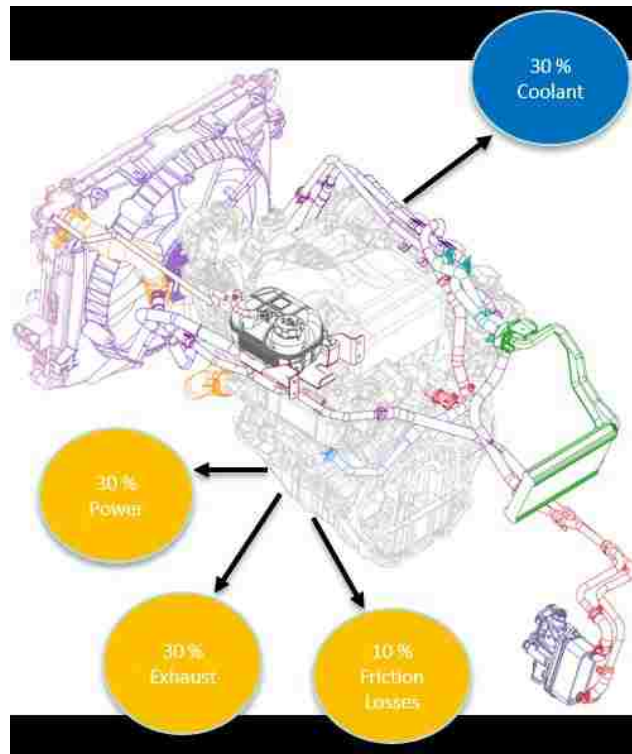

Figure 1. 1 – Engine heat rejection breakdown [1].

Most current production vehicles rely on liquid coolant to flow through the engine cooling loop via plumbing lines, to reach a number of components within the system. Typically, this coolant is a mixture of water and antifreeze, which characteristically has a higher boiling point and lower freezing point than water alone. In addition, while working to regulate the system temperature, the ideal coolant should neither cause nor promote corrosion throughout the system. The components of the system include a number of heat exchangers with passages for coolant to flow through, that either absorb or dissipate the heat, generally in exchange with air or oil.

The complete engine cooling system incorporates plumbing lines, which connect and provide channels for coolant flow to and from components, a thermostat which controls when coolant flows to peripheral components of the system based on coolant temperature, and the water jacket, which provides an intricate geometry of passages for coolant to flow through the engine.

A summary of the system coolant flow path is given below:

1. Coolant leaves the water pump and passes through the water jacket.
2. Before reaching operating temperature, cold coolant leaves the water jacket and flows past the closed thermostat via the bypass pipe to recirculate through the water jacket.
3. Once at operating temperature, hot coolant leaves the water jacket to flow through the open thermostat into a network of plumbing lines.
4. The plumbing lines supply coolant to pass through the tubes, plates or shells of each heat exchanger.
5. Plumbing lines return coolant from each heat exchanger back to the pump to repeat the loop over again.

In reality, this path is quite complicated with a variety of geometries, materials and subassemblies, all relying on each other to function correctly. For example, if a plumbing line diameter is too small, inadequate coolant flow will reach the heat exchanger, or if a water jacket gasket hole is misplaced, engine overheating can occur. This is why establishing a robust coolant circuit is so critical as a first step to designing a fully functioning engine cooling system which incorporates all flow passages and components.



Predicting the engine cooling requirements of various vehicles, and how to sufficiently satisfy them, poses a particular challenge for automakers. A prior estimation of component requirements, how they interact during vehicle operation and an estimation of flow requirements are all crucial to designing an acceptable coolant loop. In recent decades, advancements in computational modelling tools have greatly increased industry capabilities for solving these fluid flow problems. System simulation is a comprehensive tool that can be used to model a number of vehicle systems (i.e. lubrication system, HVAC system, engine cooling system etc.). Each system is made up of many components, and a system simulation model characterizes each component by geometry, and/or performance data across an inlet and outlet. The interactions of these individual components are simulated with appropriate physics, referred to as 1D simulation. Figure 1.2 shows an example of a 1D system simulation model, including several heat exchangers and coolant plumbing lines. System simulation is a useful tool early on in vehicle development when limited information or data is available. In addition, system simulation saves time to reach preliminary results and overall cost for the automaker.

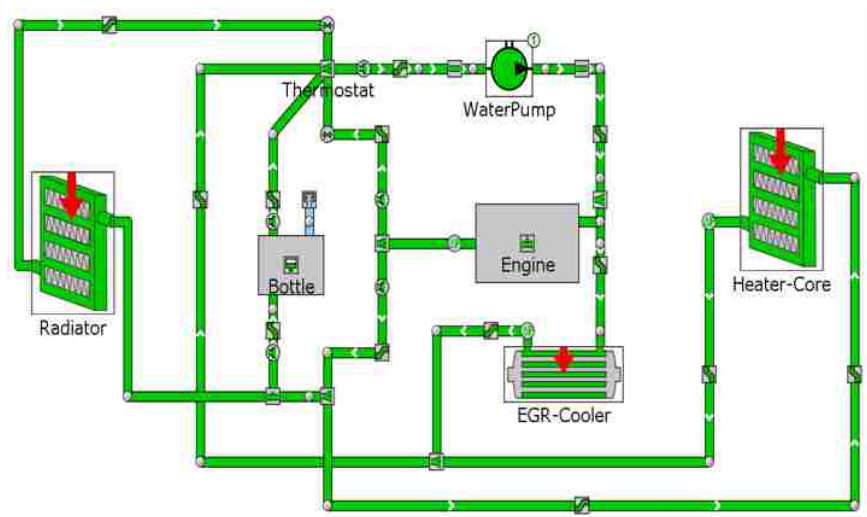

Figure 1. 2 – 1D Engine coolant loop example [2].

## 1.1 Thesis Objectives

The objective of this thesis is to accurately capture and characterize the flow behaviour of engine coolant in a vehicle engine cooling system, using a 1D system level model. The system includes heat exchangers, a thermostat, a pump, plumbing lines, and a cooling water jacket. Before the complex heat transfer phenomena occurring in the system can be analyzed, the flow behavior needs to be understood correctly. Capturing the pressure drop through the various components of the cooling system, viscous effects of working fluids due to extreme cold conditions, and appropriate representation of plumbing line and water jacket pressure drop characteristics are all important to modelling the flow behaviour. An accurate flow model is the first step towards developing a robust transient thermal model. With a good predictive model, it is possible to shorten the overall vehicle design cycle.

For both the experimental and modelling portions of this project, the engine cooling system is referred to as adiabatic. Although in reality heat exchange is always occurring between fluids and components, as that is the fundamental purpose of the engine cooling system, this work is focused strictly on the flow behaviour of coolant at a constant temperature. No external effects (i.e. air flow across the radiator, heat generated from combustion etc.) are imposed or considered.

The first part of this project involves characterizing components individually. This includes the radiator, heater core, transmission oil heater, engine oil cooler, exhaust gas recirculation cooler, coolant hot bottle, thermostat, and pump. Each component presents a unique challenge when it comes to modelling the flow behaviour. Generally, limited supplier data is available, if at all, for each component. Therefore, a component level experimental flow bench was developed to collect pressure and flow data across one component at a time, and validate component models. The second part of this project involves modelling the full engine coolant loop. To accomplish this, the plumbing lines require meticulous discretization to be converted into 1D flow components. The complex 3D water jacket geometry poses a particular challenge for 1D conversion, and existing CFD data aided in validating the flow splits generated in the 1D software. In addition, a system level experimental flow bench was developed to collect data across the complete engine cooling loop, and to validate the system model for varying pump and thermostat

conditions. Furthermore, the system level bench testing capabilities were expanded to collect data at extreme cold conditions to aid in better predicting engine coolant flow behaviour at extreme cold correctly, which is essential during the development phase of the vehicle. This was a significant development not only for experimental capabilities, but for the support it provided in validating the modelling process.

## 1.2 Thesis Organization

This thesis is organized into several chapters outlined below.

- **Chapter 2 – Literature Review:** This chapter presents the background research done during the first phase of the project. It details engine cooling design background, relevant formulae, flow theory and software tools used throughout the project to give the reader an overall understanding of the topic.
- **Chapter 3 – Experimental Flow Benches:** This chapter describes the experimental test setup for both the single component flow bench and system level flow bench, including the extreme cold condition testing. Flow and pressure instrumentation, data logging, data collection, test procedure and physical testing are explained in detail.
- **Chapter 4 – Component Level Investigation:** This chapter explains the detailed investigation done at the component level for each of the heat exchangers and pump including all part dissection, modelling and model validation.
- **Chapter 5 – System Level Investigation:** This chapter explains the detailed investigation done at the system level including conversion of the 3D plumbing geometry into 1D flow components, complex water jacket study, thermostat operation, system modelling and model validation. Results and analysis on how to achieve model correlation for extreme cold condition are discussed.
- **Chapter 6 – Conclusions:** The final chapter expresses the conclusions of the project and recommendations for future work. Important factors that affect flow in 1D modelling are described and a confidence interval on results between experiments and modelling is provided.

## 2. Literature Review

This project involves research on a mid-size internal combustion engine, and more specifically its coolant loop. All background information on the components associated with the coolant loop, as well as the coolant itself, is discussed in this literature review. Past work on engine cooling design and performance is highlighted. Furthermore, a background on system simulation and how this tool can be used in engine cooling is outlined in detail.

### 2.1 Engine Cooling

Automakers introduced engine cooling to control and mitigate the heat rejection of an internal combustion engine. Many variables need to be considered in the design process, such as boiling point of the coolant, specific heat, inlet air velocity and heat rejection values, and the relationship between all these variables must be carefully weighed. Research shows that an adequate flow rate of coolant is essential for the avoidance of hot spots in the engine and acceptable heat dissipation performance by the engine cooling system [3].

#### 2.1.1 Design Process

Engineers have successfully designed and built vehicles for both commercial and personal use for over 100 years, and as time progressed the dimensions and specifications of individual components became standardized, allowing parts to fit together without adjustment. Ultimately this led to mass production and, although vehicles have been refined by performance improvements and shape changes, the fundamental function of vehicles has never changed [4]. Engine internal flow requirements dictate the internal flow subsystem parameters. Under all engine operating conditions, the local coolant flow rate should always be greater than the flow rate at which the onset of flow instability due to vapourization occurs. Moreover, engine coolant flow rate should be less than the flow rate which causes measureable erosion, and sufficient to purge any accumulated air or vapour, under all operating conditions [4]. The pump characteristic/supply curve plots the pressure rise across the pump versus flow rate and illustrates the possible flow rate/pressure rise combinations that a given pump at a single RPM can supply. The possible combinations of flow rates and pressure rise required by a system is illustrated with the system resistance/demand curve (Figure 2.1). The pressure difference trends

upward because the frictional losses increase as the flow rate increases. The operating point where these two curves meet is the point at which the flow rate and pressure rise provided by the pump is equal to that which is required by the system [4]. Onset of flow instability (OFI) is the point at which the flow rate through the coolant plumbing falls below a critical value and vapour bubbles begin to block the flow; increased pressure becomes necessary to maintain required minimum flow. The system must be designed to supply a flow rate well above the critical flow rate to avoid the onset of flow instability and engine overheating [4].

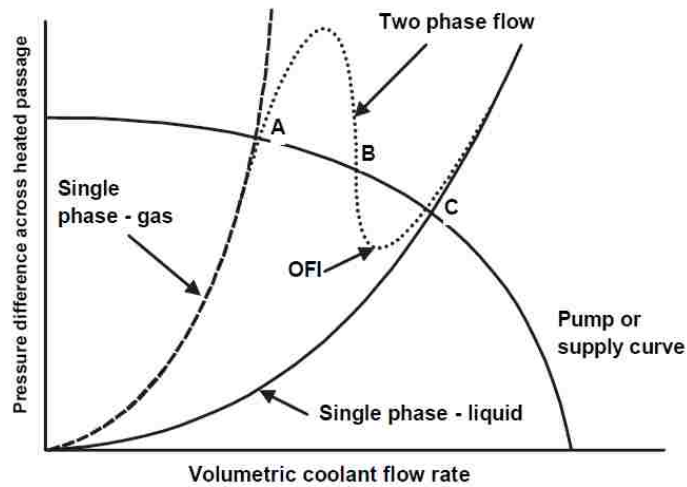

Figure 2. 1 – Onset of flow instability in engine cooling system [4].

### 2.1.2 System Breakdown

#### i. Coolant

Engine coolant is a mixture of water and antifreeze. The antifreeze used in the present study is ethylene glycol, which lowers the freezing point of water-based coolant and increases its boiling point. A 50-50 water to antifreeze mixture is desirable, to ensure a wide range of temperatures at which the coolant can remain in liquid phase and for optimal specific heat capacity. Tables 2.1 lists freezing point for antifreeze, ranked by the percentage of ethylene glycol contained in the mixture. Antifreeze also includes corrosion inhibitors to protect the engine and cooling system against degradation [5].

Table 2. 1 – Coolant freezing point by antifreeze percentage [5].

Ethylene Glycol Solution (% by volume)		Freezing Point						
		0	10	20	30	40	50	60
Temperature	(°F)	32	25.9	17.8	7.3	-10.3	-34.2	-63
	(°C)	0	-3.4	-7.9	-13.7	-23.5	-36.8	-52.8

ii. **Radiator/Heater Core**

A radiator is a heat exchanger which aids in keeping the system at the optimal operating temperature by rejecting excess heat generated by the engine to the ambient air. A tube and fin heat exchanger is shown in Figure 2.2. Hot coolant flows along the internal passages of the engine through many thin tubes of the radiator located at the front grille of the vehicle. Airflow passes perpendicular to these coolant tubes through fins to bring down the coolant temperature. The airflow is both induced by the moving vehicle, known as ram air, and the cooling fan mounted underneath the hood of the vehicle [6].

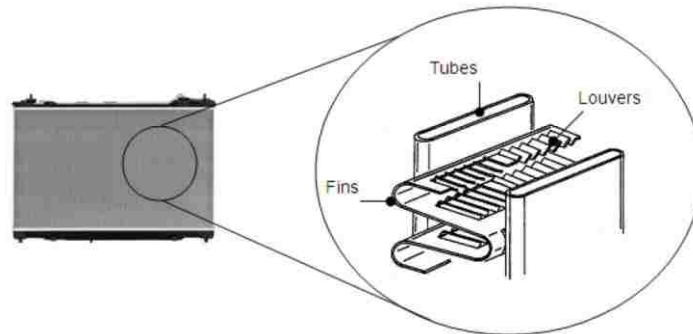

Figure 2. 2 – Radiator exterior and internal geometry [6].

Similarly, a smaller radiator, called a heater core, serves to warm the vehicle interior by use of a blower fan forcing air across the warm coolant lines into the cabin.

iii. **Exhaust Gas Recirculation Cooler**

The thermal efficiency of internal combustion engines can be enhanced by increasing the rate of exhaust gas recirculation (EGR) to help achieve lower temperature combustion. However, if the EGR rate is too high, the flame speed of ignition becomes unstable and overall engine efficiency goes down [7]. Therefore, an exhaust gas recirculation cooler (EGRC) is introduced to aid in reaching low in-cylinder temperature by cooling the intake exhaust gas (Figure 2.3).

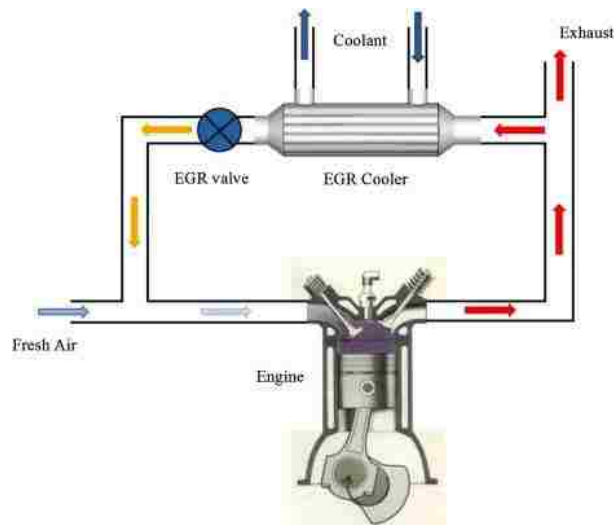

Figure 2. 3 – General schematic for EGRc exhaust and coolant sides [8].

This is also a tube and fin heat exchanger, in which hot exhaust gas passes through fins in one channel and is cooled by liquid coolant passing through the opposite channel.

#### iv. Oil Cooler/Heater

Engine oil and transmission oil are used to lubricate the components of their respective circuits, to improve overall efficiency and increase their lifespan. Depending on the stage of engine warm up or load, a heat exchanger is used to cool or heat oil by use of a plate heat exchanger. In this type of heat exchanger, oil flows between corrugated plates and liquid coolant flows between alternating passages inside the heat exchanger, to either absorb or give off heat to the adjacent oil passages [9]. The engine oil cooler is typically mounted directly on the engine and supplied with inlet coolant flow from the water jacket (Figure 2.4), while the transmission oil heater is generally an extension of the plumbing connected to the transmission.

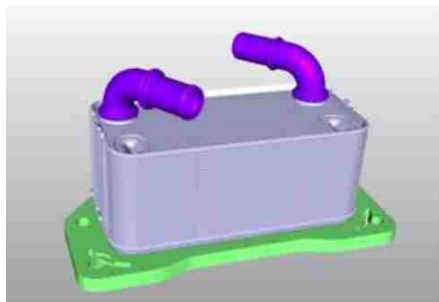

Figure 2. 4 – Engine oil cooler showing coolant supply and return lines [9].

v. *Hot Bottle*

A hot bottle (or degas bottle) is used in the engine coolant loop to provide space for expansion under high heat conditions. Located at the highest point in the system, this bottle is not for overflow, but rather provides a cushion of air to allow for the coolant to expand, and contains sufficient coolant to avoid pulling air into the system (in the case of contraction, or liquid shift) [10]. High flow rates throughout the engine cooling system can cause air bubbles to form, and these bubbles will naturally migrate to the highest point in the system. Without the hot bottle, these air bubbles would degrade the coolant heat transfer quality and could ultimately lead to the engine overheating.



*Figure 2. 5 – Hot bottle internal coolant distribution [10].*

Although a hot bottle has one inlet and one outlet, there are numerous chambers, baffles and passages (Figure 2.5) within the bottle that the coolant must flow through to allow for aeration and prevent system starvation.

vi. *Pump*

A mechanical, centrifugal pump is mounted to the engine and driven via the crankshaft by a belt system with a fixed pump-speed to engine-speed ratio. As the engine speed increases, the heat being produced also increases, and therefore the need for cooling capacity increases.



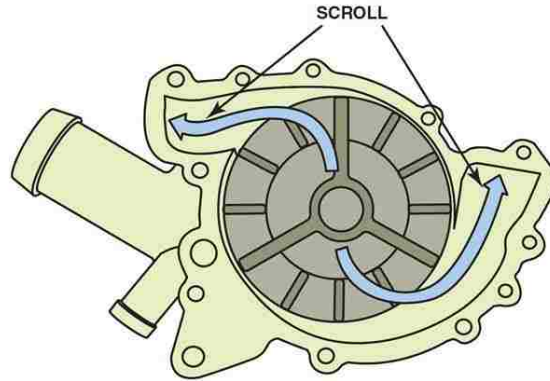

*Figure 2. 6 – Pump coolant side with two scroll exits [11].*

Coolant leaves the pump through a smoothly curved scroll passage to enter the warm cylinder block (on two sides in the case of a V style engine block, see Figure 2.6), then circulates through the hot head passages, out to the radiator where it cools and recirculates back through the engine cooling system. Ultimately the pump is used to circulate coolant through the entire engine cooling system and overcome pressure losses [12].

*vii. Thermostat*

A thermostat is used to control flow of coolant through the engine cooling system. A wax-pellet valve (Figure 2.7) will open when the engine and the coolant passing through it approach operating temperature (in the range of 95 to 100°C) [13]. A small bypass passage allows coolant to flow past the seat of the closed thermostat under cold conditions. Coolant will continue to cycle through this bypass until the engine heats up sufficiently and the thermostat opens. Upon opening, the thermostat valve then allows coolant to flow to the peripheral heat exchangers to begin the process of cooling via the radiator.



*Figure 2. 7 – Thermostat wax pellet valve system [1].*

### *viii. Plumbing*

A variety of pipes and hoses are used to supply coolant to each component in the engine cooling system, and return the coolant back through the engine block to repeat the cycle. This plumbing circuit is designed to withstand high and low temperature extremes and be flexible enough to withstand vibrations that occur under the vehicle hood [14].

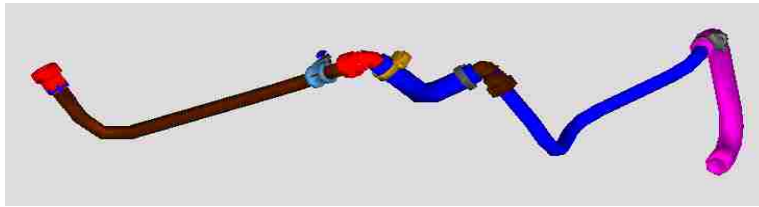

*Figure 2. 8 – Plumbing assembly example [14].*

The geometry and layout of the plumbing circuit is dictated by the availability of space under the hood of the vehicle. The cross-section of each plumbing section needs to allow for sufficient coolant flow while mitigating unnecessary pressure losses. Clamps are used to connect multiple hose sections and to connect hoses to components (Figure 2.8).

### *ix. Water Jacket*

The water jacket includes the internal engine passages through which the coolant flows. This complex geometry surrounds and/or passes through the pistons, cylinder bores, cylinder block and head. Its main function is to allow heat generated within the combustion chamber to be dissipated to the coolant.

The three main sections of the water jacket are the block passages, head passages and the gasket between these two (Figure 2.9). The gasket is made up of many small holes that act as conduits between the block and head, and ultimately these holes govern the flow and distribution of coolant. It is desired to have a well distributed flow of coolant around all engine cylinders, resulting in more efficient heat transfer from the heated engine surfaces. The gasket hole dimensions and intricate passage geometry contribute to overall pressure drop. Optimizing these water jacket features is key to optimizing the system performance. A significant amount of time and effort is invested by engineers in troubleshooting and optimizing water jacket designs [15].

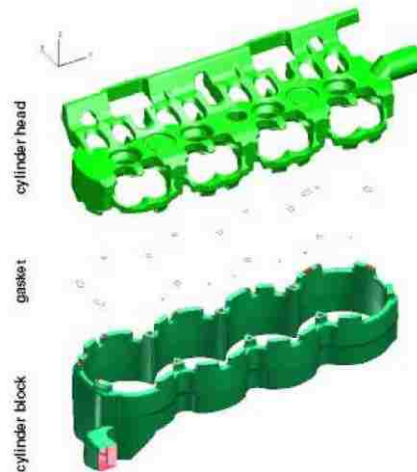

*Figure 2. 9 – Water jacket block, gasket holes and head [15].*

### 2.1.3 Literature Review of Previous Experimental Studies

The behaviour of coolant through an engine cooling system has been experimentally studied by use of varying test stands and flow bench set-ups. For the purpose of engine cooling research, the performance of the combined system of components, or individual components, is typically characterized by one or more of the three following factors: pressure, flow rate and temperature.

To assess the effect of cooling system configuration, Cehreli [12] compared two different layouts, particularly alternate plumbing configurations of the oil cooler, by performing experimental tests which collected pressure and flow data at elevated temperatures of 75°C, 92°C and 100°C across each heat exchanger (radiator, EOC, heater core and EGRc) in the system. They concluded it was important to reduce hose bends and increase hose diameters to increase overall flow rate of coolant, which ultimately led to achieving the minimum coolant system pressure limit and avoiding cavitation that could occur if the pressure were to fall below the saturated vapor pressure anywhere in the system. This is an important insight to the significance of plumbing layout and dimensions, and how this ultimately affects the available coolant flow throughout the system. A similar style of experimental study was later performed by Krakowski [16], using a test stand which extended data collection to elevated temperatures up to 120°C, however only including the radiator, water pump and engine in the test configuration (Figure 2.10). This study

was focused on the operation of the cooling intensity control, by varying the degrees to which the system was filled with coolant (80% through 95%) and how each of these conditions affects the overall system pressure drop. Ultimately it was concluded that the pressure limit of the system is best regulated at 90% coolant fill level, with the remaining 10% acting as a pressure accumulator. This is key to understanding the sensitivity of an engine cooling system relative to coolant quantity and how to navigate the varying conditions at which the coolant must perform despite changes in temperatures. Chastain et al. [17] studied the radiator, water jacket and thermostat interaction, which included the use of an electrically powered fan to replicated the heat exchange between airflow and coolant flow at the radiator. This study focused exclusively on the collection of high temperature data and involved instrumenting each component with thermocouples to determine the distribution of heat throughout the engine. The results are fundamental in demonstrating how each component in the system affects the next by capturing the temperature distribution and how it changes when external factors are introduced.

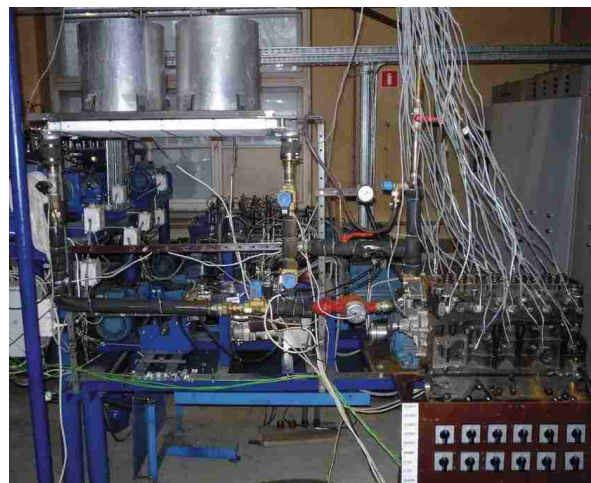

*Figure 2. 10 – Example of instrumented engine cooling test bench [16].*

Experimental studies specific to one component from an engine cooling system have also been performed. Mehravaran and Zhang [10] demonstrated the use of a test stand specifically for investigating coolant flow through a hot bottle, for the purpose of ensuring adequate and even coolant distribution was achieved. The inlet and outlet were plumbed with coolant lines and the flow was imposed through the use of an electrically driven pump in controlled increments. The maximum flow rate which the component could sustain was concluded based its ability to

maintain degassed coolant (i.e. limiting the formation of air bubbles and in turn the degradation of heat transfer). This study shows the importance of establishing adequate coolant flow through one component before moving on to evaluate coolant flow through the whole system. Saidi et al. [18] studied radiator performance, through the use of a dynamometer facility which imposed moving vehicle conditions. In this study, data was collected specific to the air side pressure drop with the use of pitot tubes, relative to vehicle speed and coolant flow rate. Studies such as this are performed with the vehicle engine running, to include both fluid sides related to the exchange of heat for a particular component, however the focus is not on the coolant flow side.

Although engine cooling experiments and flow benches have been developed in the past which incorporate a limited number of engine cooling components, or incorporate a limited number of conditions for one component, the literature is lacking to support proof of coolant side specific data collection, either at component level or for a full system. The aforementioned experimental work has been focused on elevated coolant temperature ranges, however it is important to also investigate flow behaviour at extreme cold conditions to better understand coolant flow behaviour at the full range of temperatures a vehicle cooling system would be required to perform under, at a component and system level. Kneba and Smieja [20] reinforced that the temperatures and pressures that a cooling system can maintain are dependent on the viscous properties of the liquid coolant. Gu and Ni [19] studied heat exchanger performance experimentally, by replacing the radiator of a simplified vehicle circuit with a generic intensive heat exchanger and passing cold water over the (traditionally) air side, however the other components in the system set-up remained at ambient condition. A set up such as this provides insight into the flow behaviour of coolant at cold temperatures, however it lacks the contribution of the complicated geometry that the coolant needs to pass through in an actual radiator and the complicated plumbing network to which it is attached. Furthermore, a detailed study and collection of data specific to water jacket coolant flow is lacking in existing literature, which is key to understanding overall cooling system flow behaviour. Meticulous and well thought out instrumentation of the water jacket is necessary to capture and analyze flow data throughout the intricate geometry.

## 2.2 System Simulation

### 2.2.1 System Design Principles

Requirements for the design of vehicle cooling systems are developed using system engineering principles to show how a systematic approach can maximize value, by improving the function, quality, reliability and production time for an engine cooling system (Figure 2.11). Traditionally the focus of the engine cooling design has been on the extremes of operation. However, these extremes don't represent the typical operating conditions that concern the vehicle owner. The vehicle owner expects the system to be consistently robust from the day the vehicle is produced and every subsequent day it is driven. Corporate and commercial requirements also place constraints on the design of the cooling system. Overall powertrain and vehicle design dictate the design schedule and details for the cooling system, including the physical location of components and available space for placement. For engine cooling systems, the number of functional requirements is considerable. Vehicle requirements, customer requirements, business requirements, legislative requirements and powertrain requirements all come into effect [4].

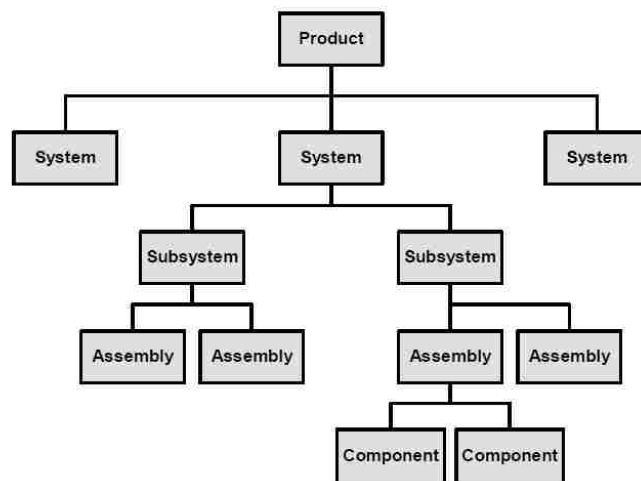

Figure 2. 11 – Automotive product design tree [4].

As far back as 1965 it was recognized that, with a growing awareness of the complexities involved in the engine cooling design process, the use of a sophisticated computer and powerful software would become essential to efficiently research engine cooling [3]. Fortunately, simulation tools

have become more sophisticated for use in the early phase of vehicle development [21]. Specific to engine cooling, systems simulation (1D) and computational fluid dynamics (CFD) can be used to determine flow velocities (Figure 2.12). If the simulation indicates that the engine required minimum flow is close to or greater than the supplied flow rate, then the design must change to increase the flow rate to the engine [4]. This is the general principle which is applied to all parts of an engine cooling system during the simulation process.

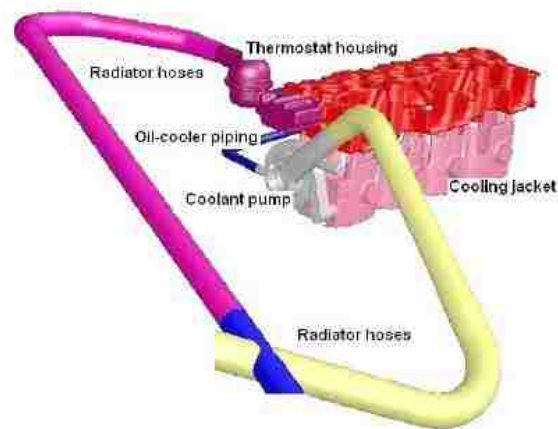

Figure 2. 12 – Computational domain for system simulation set up [15].

### 2.2.2 System Simulation Background

Simulation tools have become more prominent in the development phase of a vehicle design process, as they supersede the need for in-vehicle testing and many expensive resources. A vehicle thermal management system (VTMS) includes the gas circuit, the cooling circuit, the lubrication circuit, and the thermal capacitance of the engine under load.

A modern VTMS needs to coordinate the thermal contribution of the engine cooling system, the passenger compartment, the engine compartment, and external aerodynamics. The first phase of VTMS involves a cold engine and the need to deliver sufficient heat to the powertrain and passenger cabin in a timely fashion, while the second phase involves the warm engine and in turn the need for cooling. There is always the need for heat balance, where the heat released from the combustion chamber has to be equal to the heat transfer to the surroundings via coolant and air [21]. System simulation used during preliminary design of an engine cooling system can

provide competitive advantages, with a reduced time for the overall product development cycle and cost [22].

A flow network is created to represent the interaction between numerous components within a system. The results derived from 1D simulation of an engine coolant loop can be used for correlation with experimental results, and as input to additional models that represent interactions with other systems within a vehicle, including 3D CFD. Figure 2.13 shows a 3D flow split being modelled using CFD software, with 1D results as inputs for each boundary.

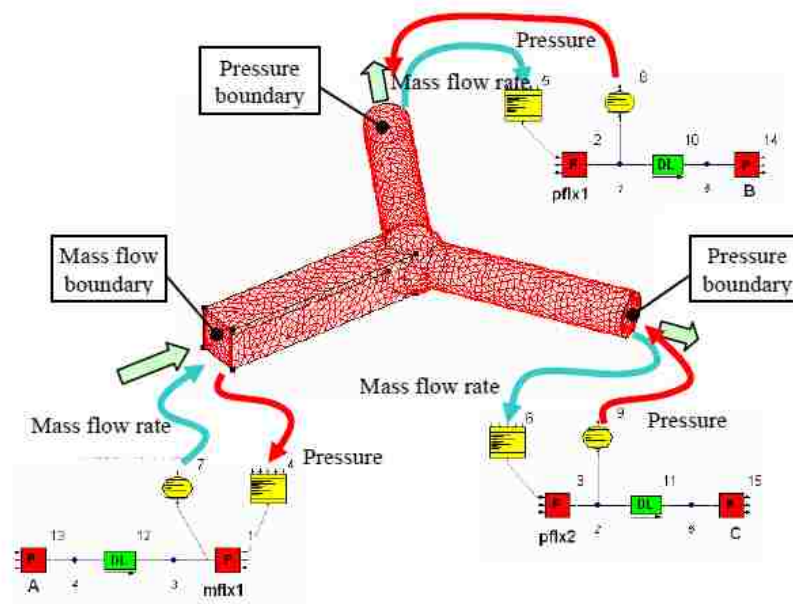

Figure 2. 13 – Data exchange between 1D network model and 3D CFD model [23].

### 2.2.3 Governing Equations

A 1D flow model involves the solution of the conservation of mass, momentum and energy equations [2]. These equations are solved in one dimension, meaning all quantities are averages across the flow direction. The system being modeled is discretized into multiple volumes and these volumes are connected by boundaries (Figure 2.14). A staggered grid arrangement is employed wherein scalar variables, such as pressure, are assumed to be uniform over each volume and vector variables, such as velocity, are calculated for each boundary [2].



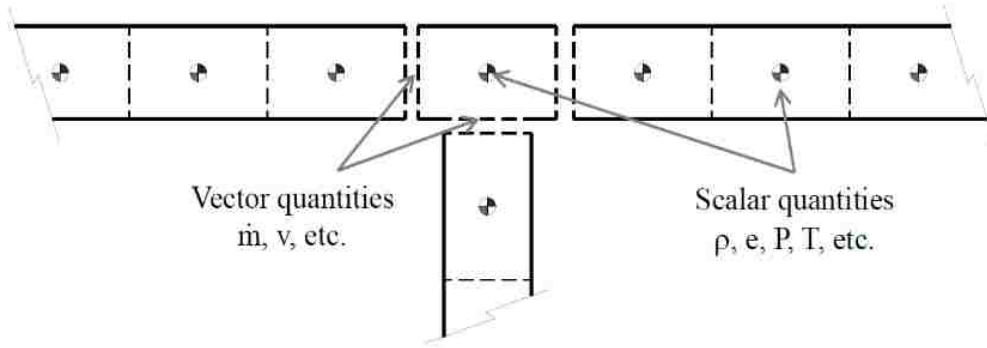

Figure 2. 14 – Schematic of staggered grid discretization [2].

The software used for this project is GT-SUITE, a 1D platform with a comprehensive set of built-in applications which simulate the physics of fluid flow. The conservation equations solved by GT-SUITE flow problems, in general, are shown below:

Mass: 
$$\frac{dm}{dt} = \sum \dot{m} \quad (1)$$

Energy: 
$$\frac{d(me)}{dt} = -P \frac{dV}{dt} + \sum (\dot{m}H) - hA_s(T_{fluid} - T_{wall}) \quad (2)$$

Enthalpy: 
$$\frac{d(\rho HV)}{dt} = \sum (\dot{m}H) + V \frac{dP}{dt} - hA_s(T_{fluid} - T_{wall}) \quad (3)$$

Momentum: 
$$\frac{d\dot{m}}{dt} = \frac{dPA + \sum(\dot{m}u) - 4C_f \frac{\rho u |u|}{2} \frac{dx A}{D} - K_p \left( \frac{1}{2} \rho u |u| \right) A}{dx} \quad (4)$$

where

- $t$  Time
- $\dot{m}$  Boundary mass flux into volume
- $m$  Mass of the volume

$V$	Volume
$P$	Pressure
$\rho$	Density
$A$	Cross-sectional flow area
$A_s$	Heat transfer surface area
$e$	Total specific internal energy
$H$	Total specific enthalpy
$h$	Heat transfer coefficient
$T_{fluid}$	Fluid temperature
$T_{wall}$	Wall temperature
$u$	Velocity at the boundary
$C_f$	Fanning friction factor
$K_p$	Pressure loss coefficient
$D$	Equivalent diameter
$dx$	Discretization length
$dP$	Pressure differential acting across $dx$

Two different time integration methods are available to choose when setting up a flow simulation within GT-SUITE. The first is explicit, with primary solution variables of mass flow, density and internal energy. With the explicit method, the values at the new time step are calculated using values from the previous time step. The second is implicit, with primary solution variables of mass flow, pressure and total enthalpy. The implicit method solves the values in all sub-volumes at the new time step simultaneously, by iteratively solving the non-linear system of algebraic equations [2].

### 2.2.3 Project Specific Equations

This project involves the simulation of an adiabatic engine coolant loop with a focus on pressure and flow data specifically. Based on the pressure drop, flow rate and geometry, GT-SUITE calculates the non-dimensional pressure loss coefficient and Reynolds number (Re) during preprocessing for each point in the input data, based on the following equations:

$$K_p = \frac{2\Delta P \rho A_{ref}^2}{\dot{m}_1^2} \quad (5)$$

$$Re = \frac{\dot{m}_1 L_{ref}}{\mu A_{ref}} \quad (6)$$

where

$\Delta P$	Difference in total pressure
$\rho$	Density
$A_{ref}$	Reference area
$\dot{m}_1$	Inlet mass flow rate
$L_{ref}$	Reference length
$\mu$	Dynamic viscosity

During simulation, the flow rate is imposed according to this non-dimensional relationship, and the pressure drop vs. flow rate output values will respond appropriately based on changes made to the fluid temperature in the simulation set-up.

#### 2.2.4 Literature Review of Previous Simulation Work

Gu and Ni [19] demonstrated the capability of 1D system simulation software to capture the coolant flow behaviour and heat transfer of a simple, single heat exchanger circuit by using experimental results for correlation within 2.4% error, and provided that this simple model can serve as a platform to optimize a more detailed component or circuit. Furthermore, they recommend to incorporate the influence of the radiator, thermostat and water pump to further study the engine cooling performance. A study done by Soloman [6] expands on this by developing a detailed 1D radiator model, inputting a number of specifics including temperature, core size, fin thickness, coolant flow rate, and air flow rate, which proved to output a radiator performance curve that was accurate within 7% of the experimental results, and could be used to quickly approximate the size of radiator in early product development. Similarly, Liang et al.[7] continued this detailed component investigation to study the effects of thermochemical composition on exhaust gas recirculation flow rate, through a dedicated EGR. These studies provide good support towards the necessity of modelling components individually as a first step

in the engine cooling modelling process, and acknowledge the complicated flow behaviour that needs to be captured and calibrated on a component level before the investigation can expand to include a more intricate system model.

A number of well documented 1D investigations have been done on mechanical systems, such as a starter motor study by Michelloti and da Silva [22] and an engine power study by De Risi et al. [24]. However, limited literature is available which details the investigation of the coolant side of any one cooling component. This contribution is critical to establishing a robust 1D model for the coolant side flow behaviour, and is essential to draw conclusions on an individual component's performance. Furthermore, component level models provide the insight into possible design change opportunities that would ensure a component can meet the minimum coolant flow requirements to sufficiently remove or dissipate heat during vehicle operation. By not building a detailed component model, or simply using a black box approach, the performance and potential geometry updates cannot be sufficiently evaluated.

From a system perspective, Pathuri and Nagarhalli [25] performed a system simulation for engine cooling performance, correlated with vehicle level testing data. Their coolant circuit 1D model was isothermal and included only select plumbing, radiator performance data, and thermostat and pump characteristic curves. Air flow patterns on the radiator were imported from a 3D CFD analysis, and an overall system 1D model correlation was achieved within 8% of the experimental results. Work done by Bolehovsky and Novotny [26] highlights the necessity of including all components in a 1D engine cooling model before moving on to transient simulations, as their study attempted to utilize a simplified cooling system and it proved difficult to achieve correlation when 3D under hood airflow data was introduced.

Watanabe et al. [23] performed an engine cooling system investigation which involved co-simulation methodology, which involved the communication between 1D and 3D CFD software. Although detailed internal flow results were gained from the incorporation of 3D component results, they conclude that uncertainties in boundary conditions were reduced and overall simulation time was achieved by using a 1D system approach, while conserving overall mass in the system model.

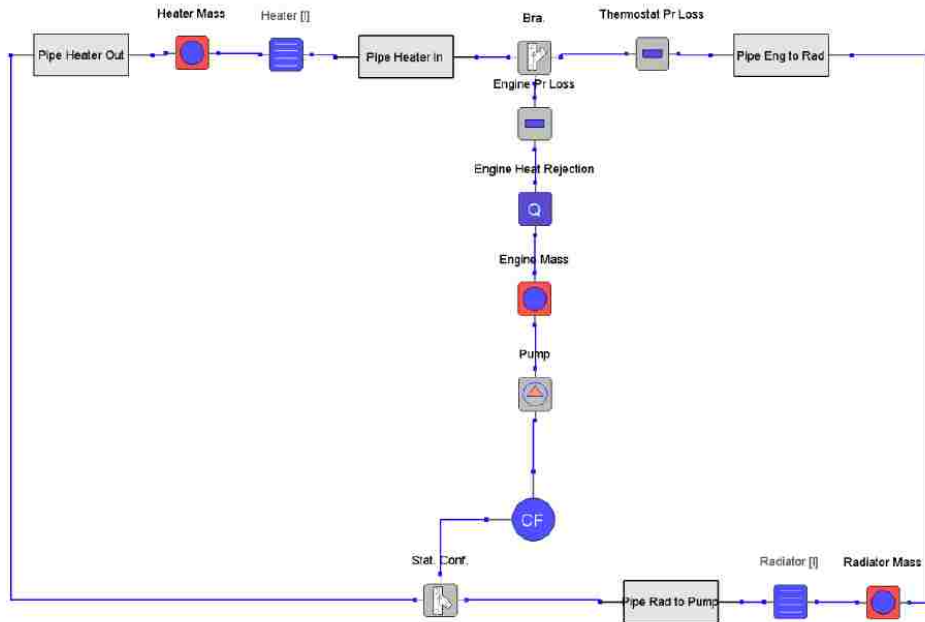

Figure 2. 15 – Simple 1D engine cooling model [25].

An engine cooling system 1D model should be robust enough to capture all system complexities. The aforementioned 1D models have been simplified with regards to the engine water jacket. The complicated 3D block-gasket-head geometry has been modelled as a simple flow split with one inlet and one outlet (Figure 2.15). This has been driven by the desire to quickly achieve validated results and generate sufficient data to move on to the next vehicle design phase. However, there is little research investigating the full engine cooling system to include a complex water jacket and all component interactions at a 1D level. In order to properly build and validate an engine cooling system level model, it is critical to do a detailed investigation of the flow behaviour through the engine, as well as through the plumbing and other components discussed above.

### 3. Experimental Flow Benches

Experimental flow benches were developed for this project to evaluate coolant flow behaviour under a variety of conditions, and collect data which can be used to validate a 1D system simulation model. These conditions include a range of water pump speeds and coolant temperatures. Flow and pressure data were collected across plumbing branches and heat exchangers to be analyzed and used in 1D modelling, but also to conform to design requirements and optimize cooling performance. These flow benches provide the ability to evaluate variable cooling system design paths, as in plumbing geometry, and a variety of components used within the cooling system. Each bench is operated by rotating the water pump using a variable frequency drive electric motor, which provides the ability to induce and control the flow of coolant through the plumbing lines. Figures 3.1 & 3.2 show the system level flow bench isometric and side views, respectively.



*Figure 3. 1 – Isometric view of engine cooling system flow bench.*

A system level flow bench was built to accurately replicate the cooling system configuration that would be found in-vehicle, including all plumbing lines and heat exchangers. A single component flow bench was also built to evaluate one heat exchanger at a time, using one inlet line and one

outlet line. The development and build of the system level flow bench and single component flow bench involved meticulous planning and attention to detail with regards to placement of instrumentation for capturing the flow and pressure characteristics. This chapter discusses the thought process and method behind designing, building, and running each experimental flow bench.



*Figure 3. 2 – Side view of engine cooling system flow bench.*

### 3.1 Instrumentation

This section will highlight the instrumentation used to collect pressure and flow data across the plumbing branches of the experimental flow benches. Uncertainty analysis for this instrumentation can be found in Appendix A. Also discussed are the thermocouples used to record coolant temperature and custom fittings created to accommodate all instrumentation.

#### 3.1.1 Pressure Sensors

To collect coolant pressure data, pressure transducers were used at several locations on each experimental flow bench. Acquired from General Electric Digital Solutions, these pressure transducers were chosen for their high accuracy and installation feasibility. Relevant specifications for these sensors are:

- Pressure range: 0 to 50 psi
- Output signal: 0 to 5 V

The transducer comes into contact with the coolant for pressure measurement by screwing the bottom threaded end into a 1/8" NPT tap, either in an in-line plumbing fitting or directly into the part (e.g. engine block). The top end then plugs into a 6-pin Amphenol mating connector and relays information to the data logger via the appropriate wiring. Figure 3.3 shows a transducer before and after bench installation.



*Figure 3. 3 – Pressure sensor, before and after bench installation.*



### 3.1.2 Flow Meters

To collect coolant flow data, flow meters were used at several locations on each experimental flow bench. Acquired from Flow Technology Inc., these turbine flow meters were chosen for their high accuracy and turbine functionality. Relevant specifications are listed below:

- Flow range(s): 0 to 10 GPM, 0 to 25 GPM, and 0 to 160 GPM
- Output Signal: 0 to 10 V

A flow meter was embedded directly into the plumbing line, and the coolant passes through the turbine blades for flow measurement. The GPM range is relative to the diameter of the plumbing, and is thus chosen to best fit the location on the experimental bench. The top end then plugs into a 4-pin Amphenol mating connector and relays information to the data logger via the appropriate wiring. Figure 3.4 shows a flow meter front and cross-section views.



*Figure 3. 4 – Flow meter, front and cross-section views.*

### 3.1.3 Thermocouples

In order to monitor and collect coolant temperature data, K-type thermocouples were used on the experimental flow benches, with the male end tapped either into an in-line plumbing fitting or directly into the part (i.e. engine block) and the female end extended to the data logger. Figure 3.5 shows a thermocouple before and after being installed on the bench.



*Figure 3. 5 – Thermocouple, before and after bench installation.*

### 3.1.4 Custom Fittings

Custom fitting were machined and embedded in the coolant plumbing lines to provide space for pressure and thermocouple taps. Furthermore, these individually designed fittings minimize change in inner diameter throughout the plumbing and ultimately reduce any obstruction of coolant flow. Figure 3.6 shows examples of custom fittings that were machined to accommodate a variety of instrumentation and plumbing dimensions.

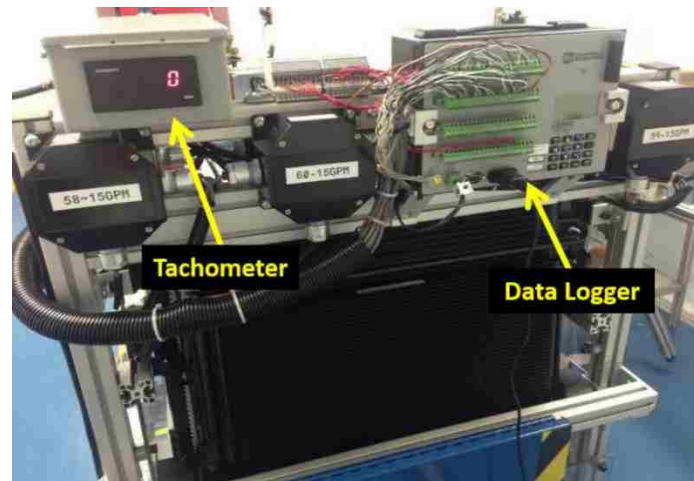

*Figure 3. 6 – Custom fittings with variable diameter ends.*

## 3.2 Data Collection

### 3.2.1 Wiring and Connections

A Campbell Scientific CR5000 data logger was mounted to each flow bench. This data logger is equipped with 28 single ended channels, (or) 14 differential channels, or a combination of both. Flow meters and pressure sensors were wired sequentially into single ended channels, using 24 AWG 4 conductor, Belden shielded instrumentation cable. In addition, flow meters were wired through a transmitter then through a terminal block before the connection was made at the data logger. Thermocouples were wired into differential channels. Figure 3.7 shows the tachometer and data logger configuration mounted to the front of the flow bench.



*Figure 3. 7 – Bench mounted tachometer display and data logger.*

A remote optical tachometer sensor was mounted to the engine front cover by a custom bracket and its laser aimed appropriately at the water pump (Figure 3.8) using a small piece of reflective tape. As the pump rotates, a laser signal is fed directly back to the panel tachometer, then to the data logger, as an RPM read out.



*Figure 3. 8 – Laser tachometer aimed at water pump.*

In order to supply each sensor with 12V power, terminal blocks were required to be mounted to the engine stand using din rail (Figure 3.9). For every 10 terminal blocks, 9 can serve as power supplies for sensors, while 1 needs to provide 12V power from the data logger. The ends of each terminal block set should be capped with an end cap. In order to tie each set of 10 terminal blocks together, a jumper screw was used.

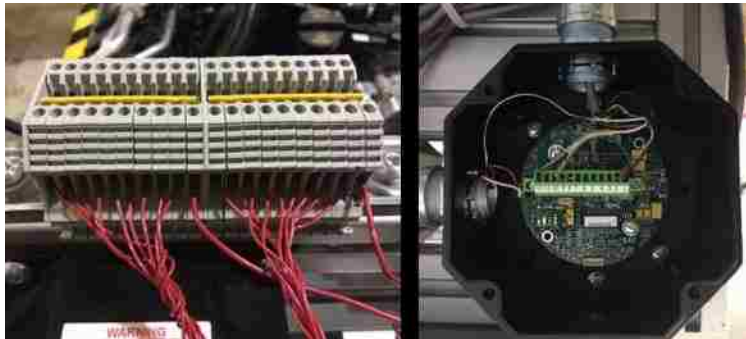

*Figure 3. 9 – Bench mounted terminal blocks and flow transmitter.*

Both flow meters and pressure sensors required Amphenol mating connectors for wiring. The flow transmitters originally came with two open ended grommets on adjacent sides, however these were replaced with Grip-Tite grommets to create a barrier from any liquid entering the transmitter in the case of spill/spray. The coolant lines were fixed with clamps at each component and engine connection, as well as for each embedded piece of instrumentation and sight glass. These served to seal the connection and prevent any coolant leaks (Figure 3.10). Hose clamps should be non-perforated, so as to avoid cutting into the rubber hoses. Varying diameters were required, depending on the diameter of the lines involved in the cooling circuit.

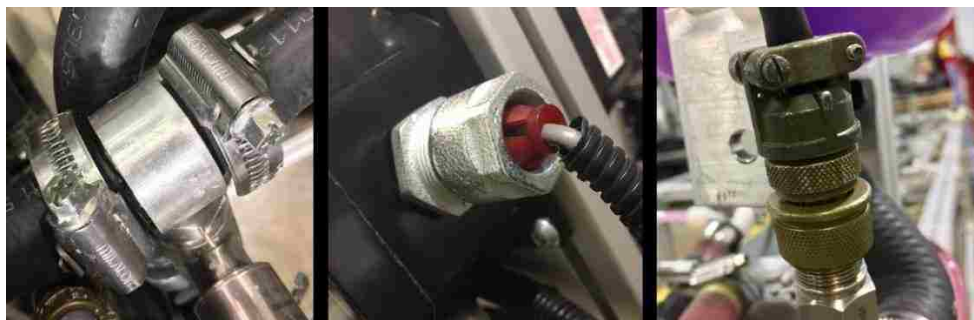

*Figure 3. 10 – Plumbing clamps, water tight grommet, and Amphenol mating connector.*

### 3.2.2 Data Programming Software

The laptop used for testing was equipped with the Campbell Scientific Logger Net software. A program was written within the Logger Net software, under the built-in editor function, for each flow bench specific to the number of sensors used during the test. Flow meters and pressure sensors were wired sequentially into single ended channels. Each sensor comes calibrated with a specific sensor range, and a scaling factor must be used to calculate the multiplier in the program.

### 3.3 Single Component Flow Bench

The purpose of the single component flow bench is to investigate flow and pressure characteristics across one component at a time, to cross-reference the data which is given by suppliers, and validate the individual 1D models. It is important to develop and validate component level models first before moving on to system level modelling. This flow bench is equipped with a reservoir, immersion heater, electric motor, horizontal vane pump, inlet and outlet plumbing, and a variety of mounting brackets to accommodate the specific component under investigation. The components tested on the single component flow bench are listed below:

- Radiator
- Heater core
- Transmission oil heater/cooler
- Engine oil heater/cooler
- Exhaust gas recirculation cooler
- Hot bottle

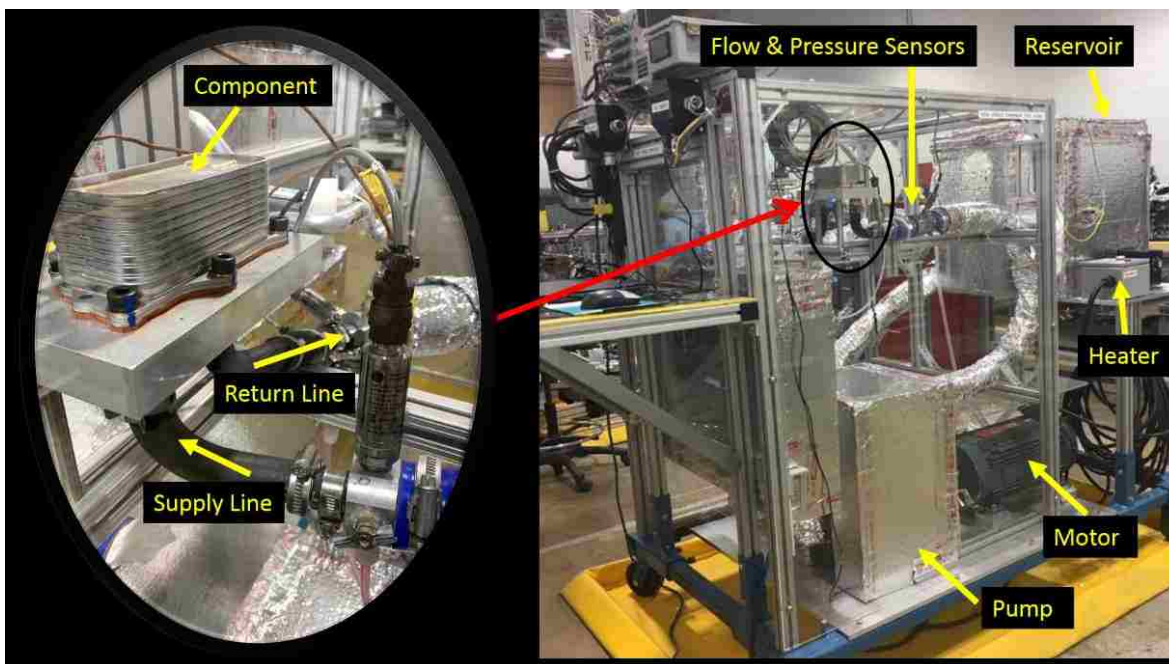

Figure 3.11 – Single component flow bench itemization.

Figure 3.11 shows the single component flow bench, with a close up on a mounted component, and labels for key parts in the system.

### 3.3.1 Flow Schematic

This flow schematic indicates the layout of the single component flow bench and direction of flow through the component (Figure 3.12). A common set of supply/return plumbing lines were used across all components, however each component has a different inlet/outlet diameter, and so a custom fitting is used for each to step down the plumbing line geometry. The supply line was instrumented with a flow meter to record flow data into the component. Both the supply and return lines are instrumented with pressure sensors to record the pressure drop across the component, as well as a thermocouple on each line to record temperature and ensure no heat is being lost.

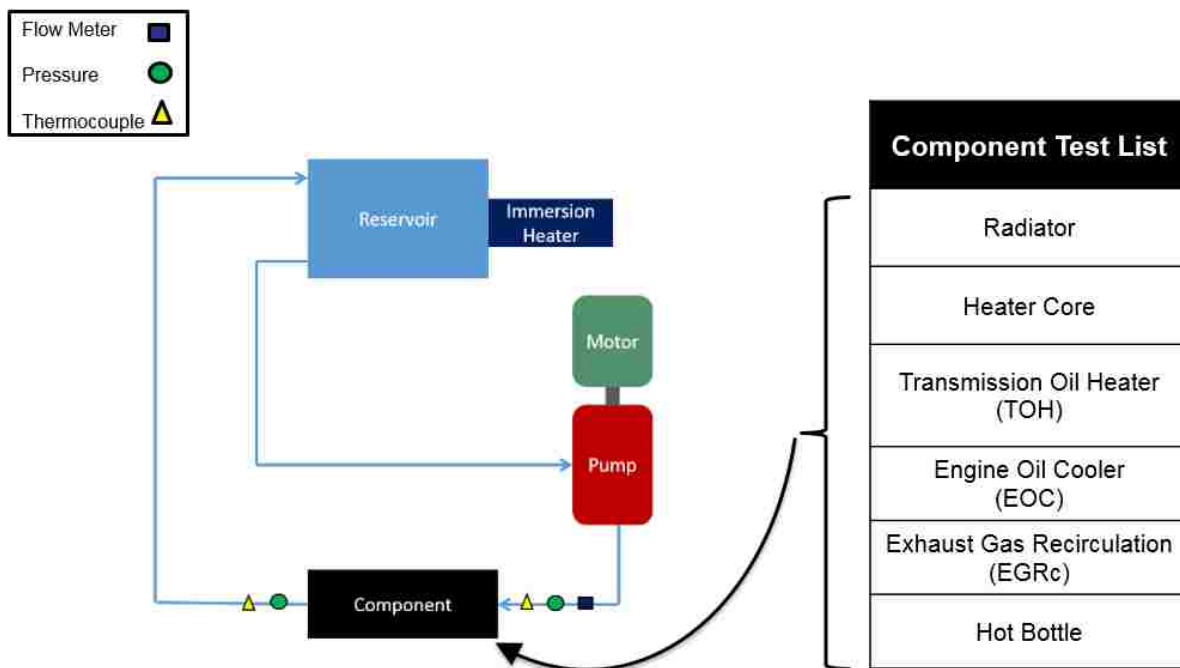

Figure 3. 12 – Single component flow bench schematic.

### 3.3.2 Run Set Up

The reservoir holds 25 gallons of liquid coolant at ambient temperature, which has been fitted with an immersion coil heater to raise the temperature for simulating in-vehicle coolant temperatures. For this reason, most elements of the single component bench are well insulated

to mitigate heat loss and ensure the work done by the immersion heater is not lost to the ambient air. This is the reason for the silver foil insulation covering the majority of the bench, to ensure the heat remains absorbed in the coolant for verifying flow behaviour at elevated temperature. The horizontal vane pump is powered via an electric motor, which is controlled via a variable frequency drive (VFD) panel (Figure 3.13).



*Figure 3. 13 – Single component flow bench reservoir and pump.*

### 3.3.3 Single Component Data Collection

Data was collected for the following components and corresponding flow ranges to represent the full sweep of coolant flow the component would experience in-vehicle. Each component was tested at both 30°C and 105°C.

- Radiator: 0 to 50 GPM
- Heater Core: 0 to 15 GPM
- EOC: 0 to 12 GPM
- TOH: 0 to 16 GPM
- EGRc: 0 to 15 GPM
- Hot Bottle: 0 to 3 GPM

Based on these conditions, below are examples of experimental data collected across the heater core (Figure 3.14) and TOH (Figure 3.15) using the single component flow bench. The



independent variable is inlet coolant flow rate, the dependent variable is pressure drop, and a 95% confidence interval is shown for each data point.

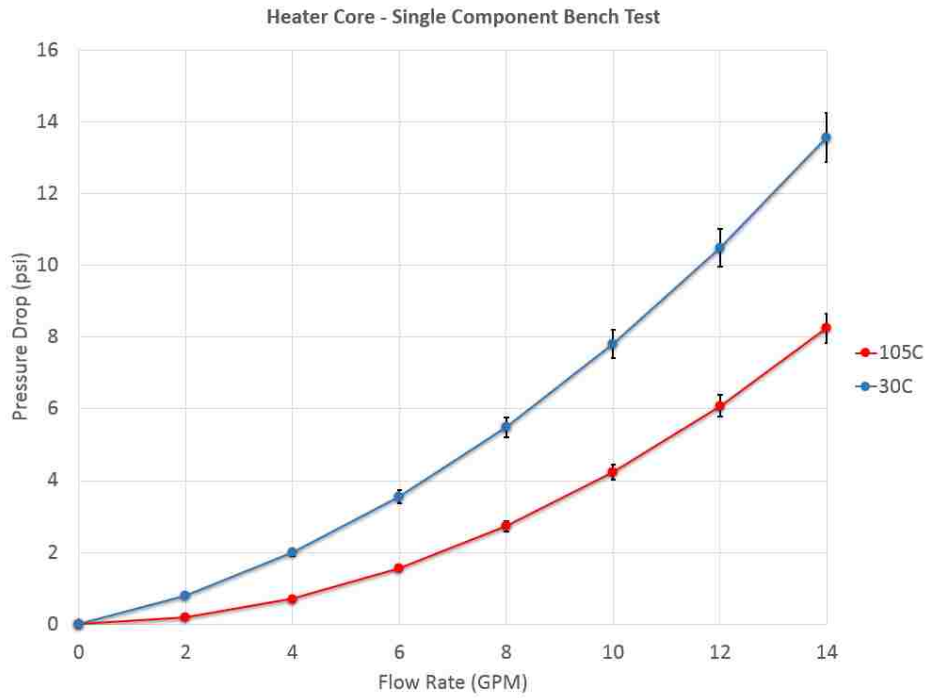

Figure 3. 14 – Heater core data collected on the single component flow bench.

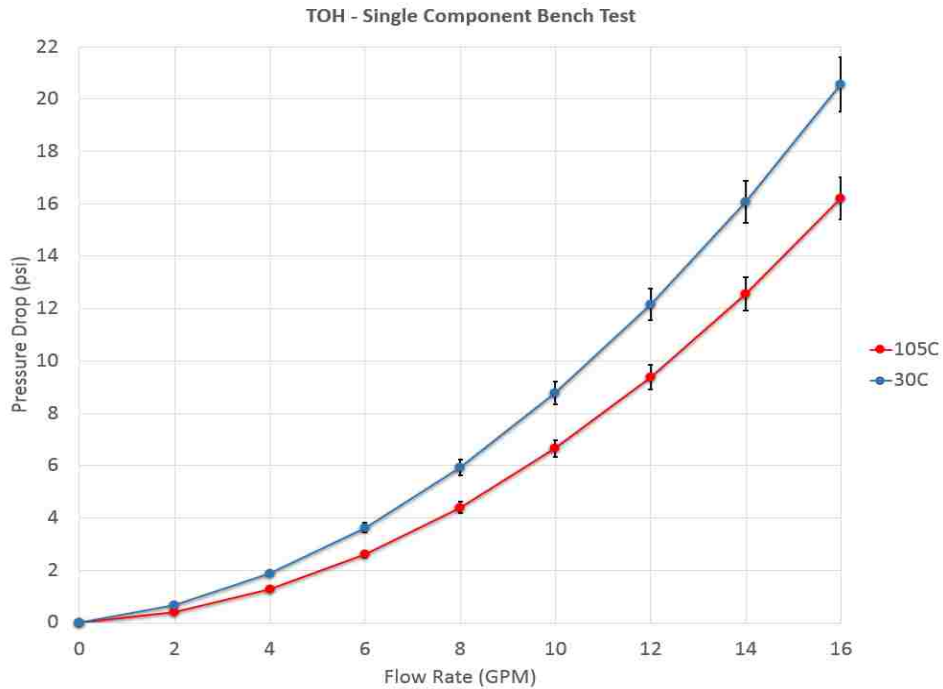
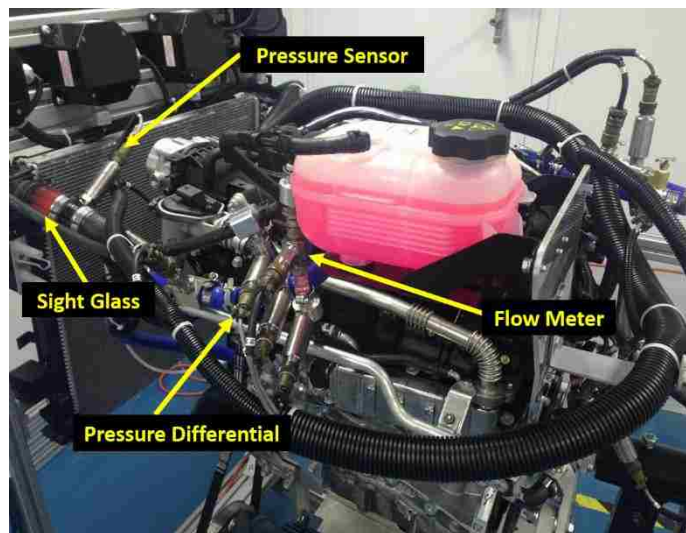

Figure 3. 15 – TOH data collected on the single component flow bench.

### 3.4 System Level Flow Bench

The purpose of the system level flow bench is to investigate flow and pressure characteristics throughout the entire engine cooling system, including each heat exchanger, the pump, the thermostat, the external plumbing and internal water jacket passages. The data collected at each location can be used to validate the system simulation 1D model. This flow bench is equipped with an engine block, all coolant loop components and plumbing lines, an engine mounted coolant water pump, electric motor and a variety of brackets to accommodate the geometric configuration of this specific vehicle's coolant loop. The system level flow bench is illustrated in Figure 3.16.



*Figure 3. 16 – System level flow bench itemization.*

#### 3.4.1 Flow Schematic

This flow schematic indicates the layout of the complete engine coolant system and direction of flow through each component in the system (Figure 3.17). Each heat exchanger has a specific set of supply/return plumbing lines, and depending on the availability of space, either line can be instrumented with the flow meter which most closely matches that plumbing line's cross-sectional diameter. Both the supply and return line of each component was instrumented with pressure sensors to record the pressure drop across the component (referred to as pressure differential). Furthermore, the engine block was drilled and tapped for pressure sensors to better investigate the flow behaviour through the water jacket (indicated in red in Figure 3.17) - more

details on this can be found in Section 3.4.3. Several plumbing lines were fitted with sight glass, essentially a clear section of rubber tubing that matches that plumbing line's cross-section diameter, which allowed for the ability to visual verify coolant is flowing through all plumbing branches (particularly useful during the initial system fill).

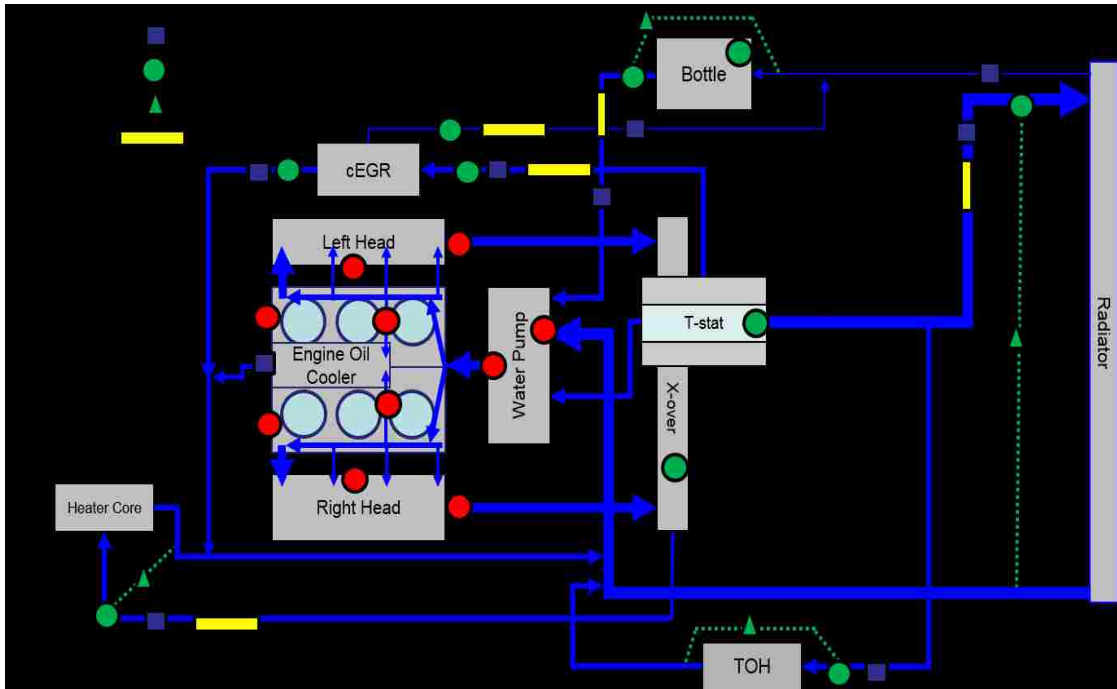
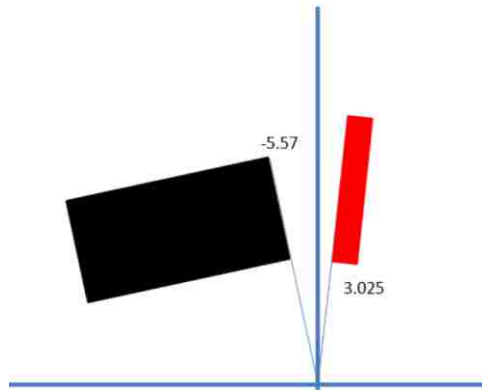

Figure 3. 17 – System level flow bench schematic.

### 3.4.2 Run Set Up

Detailed drawings were referenced to build the system level flow bench to replicate the in-vehicle configuration and dimensions as closely as possible. This included the use of top bottom, front, back, right and left side technical drawings of the engine cooling system to accurately orient and fix the block, components and plumbing in place. Simple diagrams, such as Figure 3.18, were created to indicate the angles required for setting larger components, such as the engine block and radiator, relative to the 90-degree square frame built to hold the flow bench. This is to ensure the coolant follows a path on the flow bench which closely reflects the in-vehicle path.



*Figure 3. 18 – Engine and radiator mounting angle diagram.*

3D computer generated diagrams (Figure 3.19) were also used as visual aids to reference during the build process, to replicate exactly the in-vehicle geometry and coolant behaviour that would occur during vehicle operation.

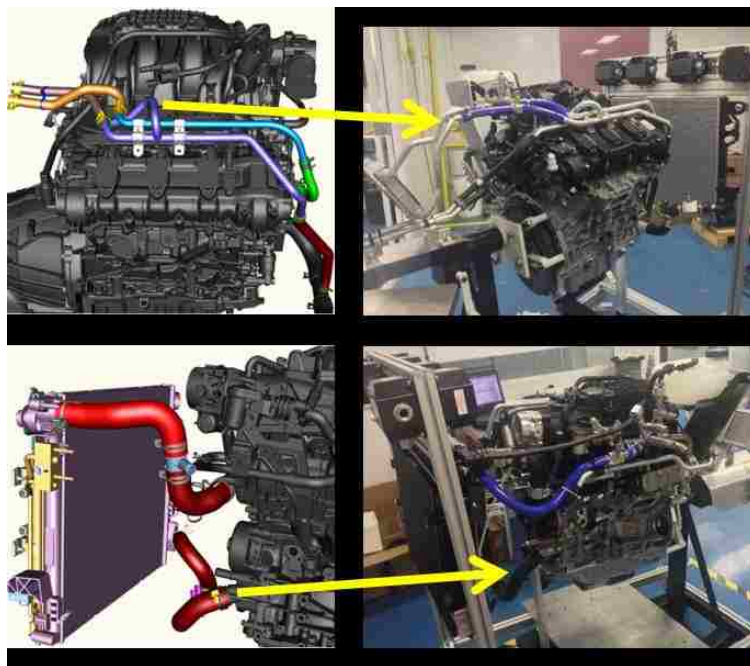

*Figure 3. 19 – 3D engine cooling system CAD compared to physical flow bench.*

As the engine transmission was not running, the coolant water pump needed an external power source to induce rotation and force coolant through the system. The flow bench was fitted with an electric motor, which drives the water pump via a pulley and belt system (Figure 3.20). By using a VFD panel system, the pump speed commenced at 1000RPM and stepped up in

increments of 250RPM every 30 seconds, until a maximum speed of 7000RPM was reached. This covered a wide range of pump speeds that a vehicle would experience under varying loads.

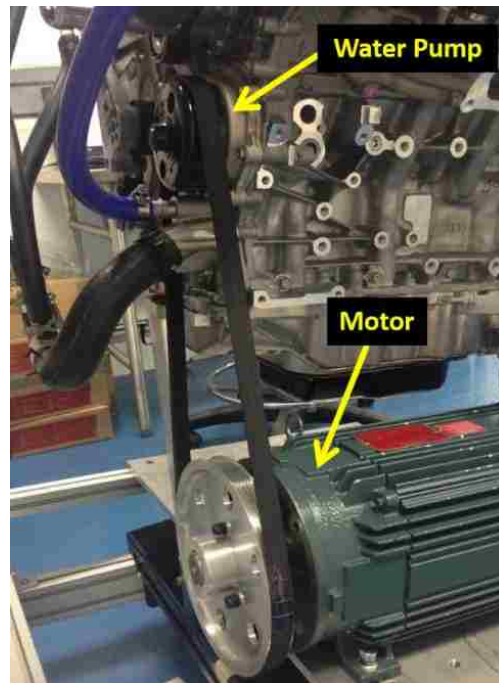

*Figure 3. 20 – Motor, pulley and belt system used to drive the water pump.*

Once again, because the engine was not running and the test was run at ambient temperature, the thermostat would not naturally open as it would when a vehicle reaches operating temperature. However, it was important for this investigation and subsequent modelling to collect data at both open and closed thermostat conditions. Therefore, a compression tower was developed and machined, by carefully threading a nut, bolt, and pin through the thermostat housing and onto the seat of the wax seal, to gain the ability for manually controlling the thermostat and ultimately the flow path of coolant through the engine cooling system (Figure 3.21).

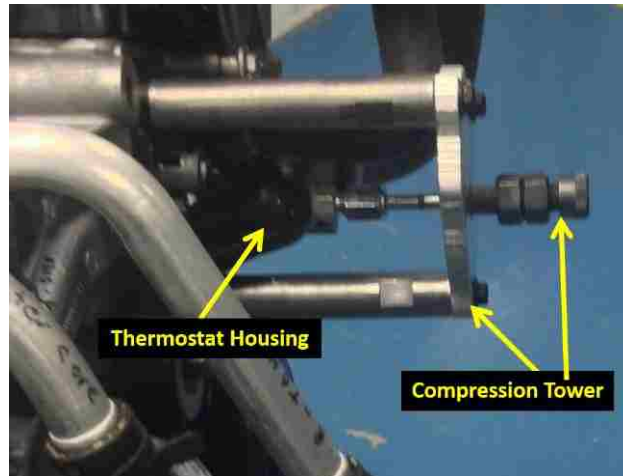

*Figure 3. 21 – Engine mounted thermostat compression tower.*

### 3.4.3 Detailed Engine Block Instrumentation

As mentioned above, the engine block was drilled and tapped for pressure instrumentation at a number of locations to better facilitate system level virtual model validation. Unlike the heat exchanger components, the engine block and water jacket do not have one inlet or one outlet to easily identify, but instead several inlets, internal flow splits, and outlets. With this in mind, the sensor locations were chosen to capture the cylinder block inlet pressure, cylinder block outlet pressure, cylinder head outlet pressure, pump and thermostat housing pressure. Figures 3.22 through 3.27 demonstrate the investigation that was done between the CAD and physical instrumentation location for the cylinder block inlet, cylinder block outlet, head outlet, pump outlet, bypass inlet and thermostat housing, as select examples.

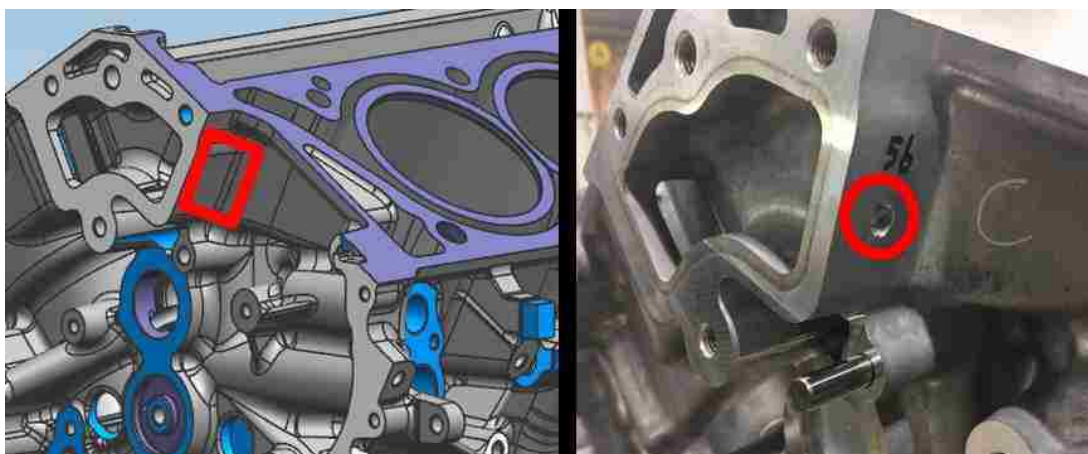

*Figure 3. 22 – Cylinder block inlet CAD to bench instrumentation comparison.*

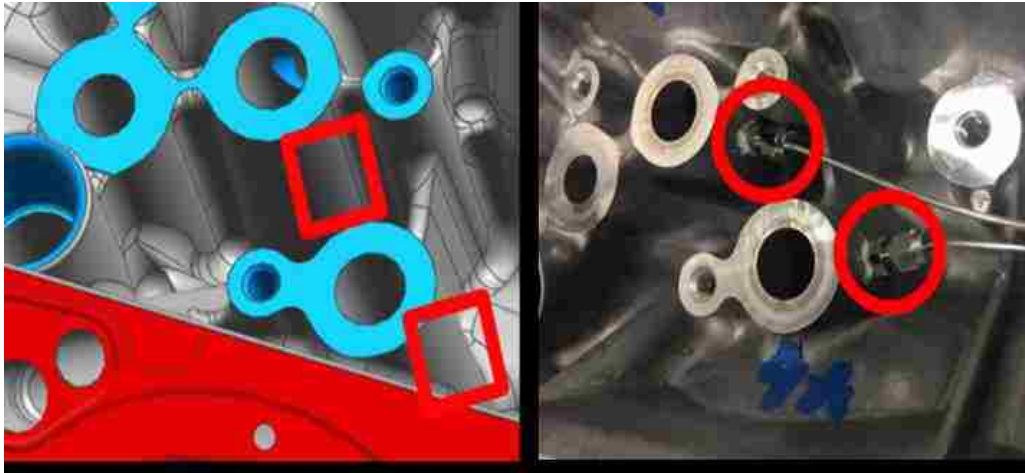

Figure 3. 23 – Cylinder block outlet CAD to bench instrumentation comparison.

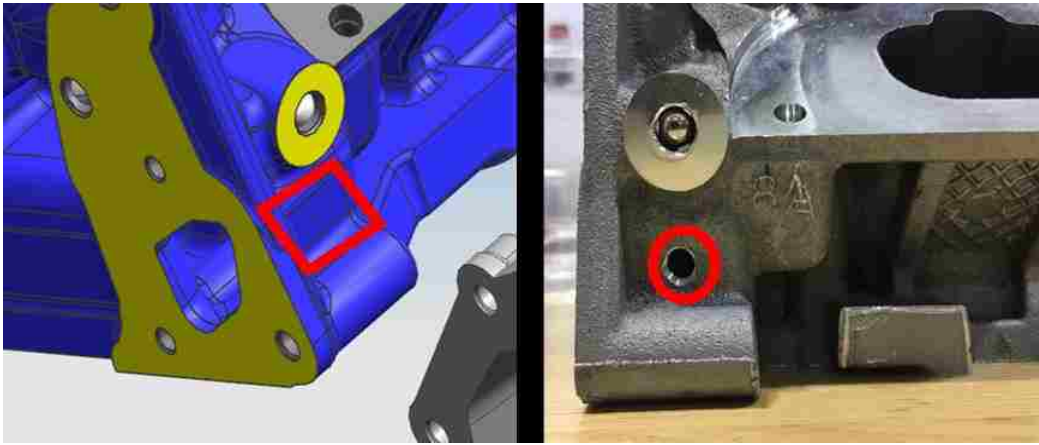

Figure 3. 24 – Head outlet CAD to bench instrumentation comparison.

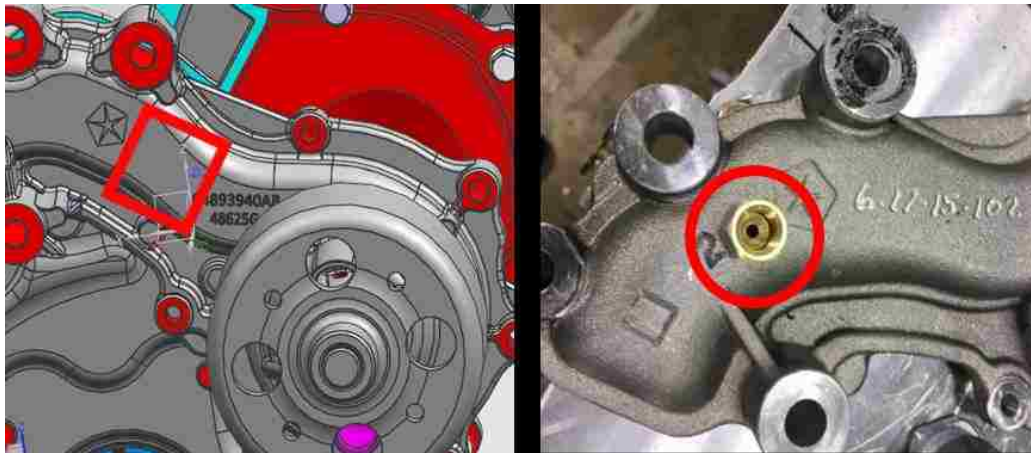
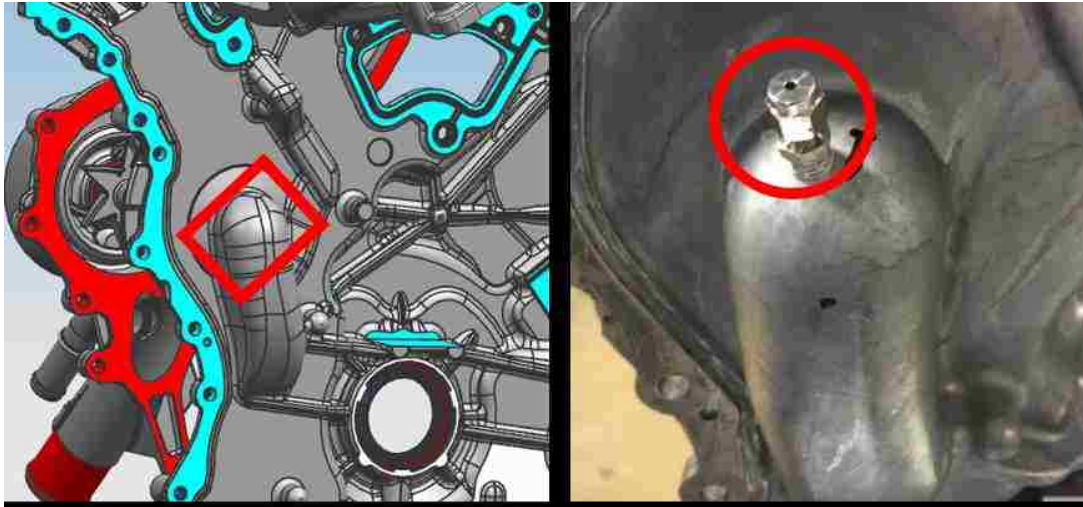
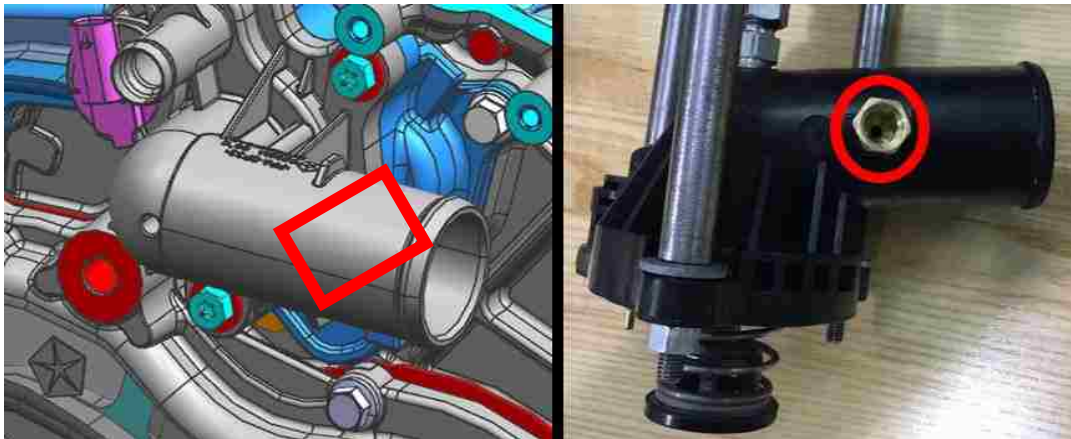

Figure 3. 25 – Pump outlet CAD to bench instrumentation comparison.



*Figure 3. 26 – Bypass CAD to bench instrumentation comparison.*



*Figure 3. 27 – Thermostat housing CAD to bench instrumentation comparison.*

The locations of these sensors were identified on 3D engine CAD and a feasibility analysis was performed first in a virtual environment, by determining the wall thickness and available clearance at each location before moving on to physically drill and tap. Due to the limited and often nonexistent space inside the engine block for pressure sensors, the instrumentation is clustered and fixed outside of the block, each corresponding to a particular tap and connected to that tap via 1/8" metal tubing (Figure 3.28).





*Figure 3. 28 – Water jacket instrumentation cluster mounted on engine exterior.*

### 3.4.4 Hot Testing

In order to raise the coolant temperature above ambient without the natural influence that would come from running the engine, a cylinder bore heating system was introduced. This allows for coolant flow and pressure data to be recorded at temperatures up to and including 110°C (i.e. engine operating temperature). First, the system level flow bench supporting structure was modified to incorporate an insulated chamber (Figure 3.29) and protect the flow transmitters, data logger and tachometer display from the high heat environment.



*Figure 3. 29 – Insulated system level bench chamber.*

Six heaters were inserted into each of the engine cylinder bores from below, where the oil pan would normally be fixed, and their connection wires run below and out of the flow bench chamber (Figure 3.30). Each heater is rated for 2000 W, and is plugged into a panel specific to controlling the heat output using a 480V supply.



*Figure 3. 30 – Engine block cylinder bore heaters.*

#### 3.4.5 Cold Testing

By making use of the same insulated chamber that was introduced for the hot testing above, the system level flow bench capabilities were extended to incorporate cold testing.



*Figure 3. 31 – Port holes on insulated chamber for cold testing.*

Two port holes, one for supply air and one for return air, were installed on the exterior of the chamber to match the piping diameter of a remote conditioning unit (Figure 3.31). This unit is powered from a 600V, 30A source weld plug. A connected thermocouple was placed inside the chamber and its temperature readout was used as a PID controlled process value which was fed back to the remote conditioning unit, with a fan on top to adjust speed to control temperature via a cascading refrigerant system (Figure 3.32).



*Figure 3. 32 – Remote conditioning unit fitted to insulated chamber.*

### 3.4.6 System Level Data Collection

System level data was collected at closed thermostat for the extreme cold condition, through to engine warm up temperatures. It is important to note that until the thermostat opens, no coolant flow occurs through the radiator or TOH. System level data was collected at open thermostat for ambient and operating temperature. The exact test conditions are listed below.

#### Closed Thermostat:

- -20°C
- -5°C
- 0°C
- 10°C
- 20°C
- 80°C

#### Open Thermostat:

- 20°C
- 110°C

Examples of the wide range of data collected on the system flow bench, across the EGRc and radiator, are shown in Figures 3.33 and 3.34.

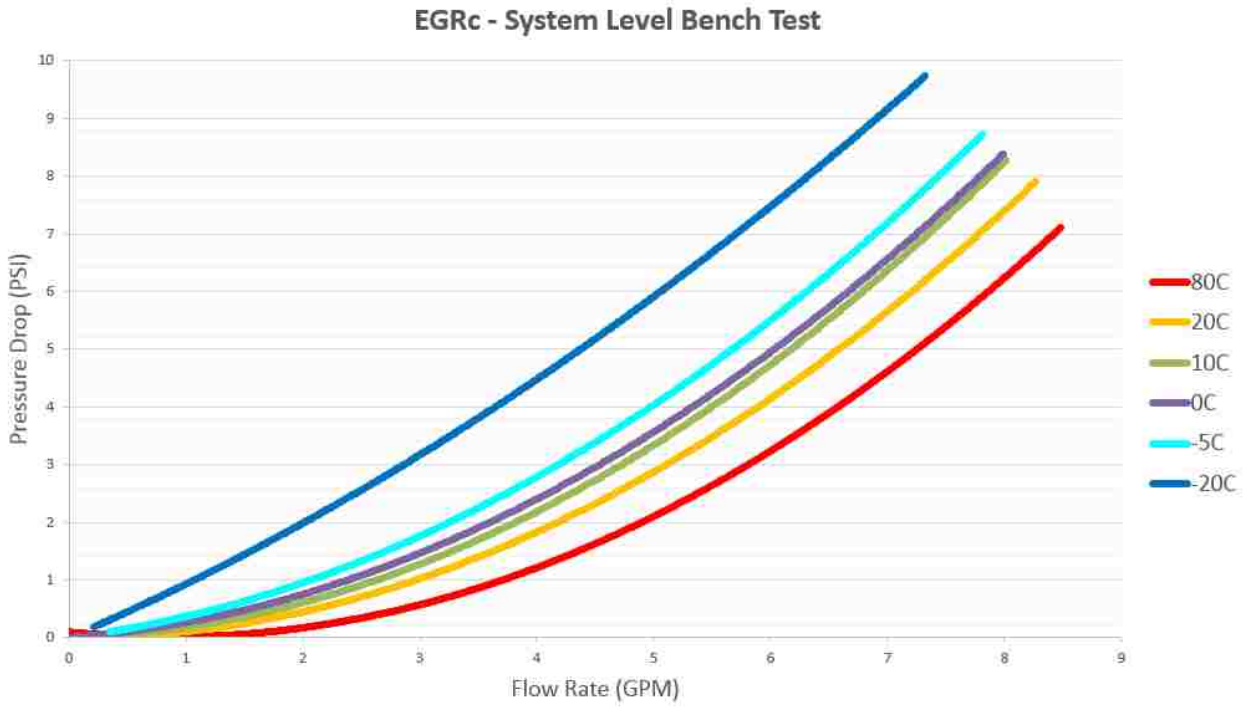

Figure 3. 33 – EGRc data collected on the system level flow bench, closed thermostat.

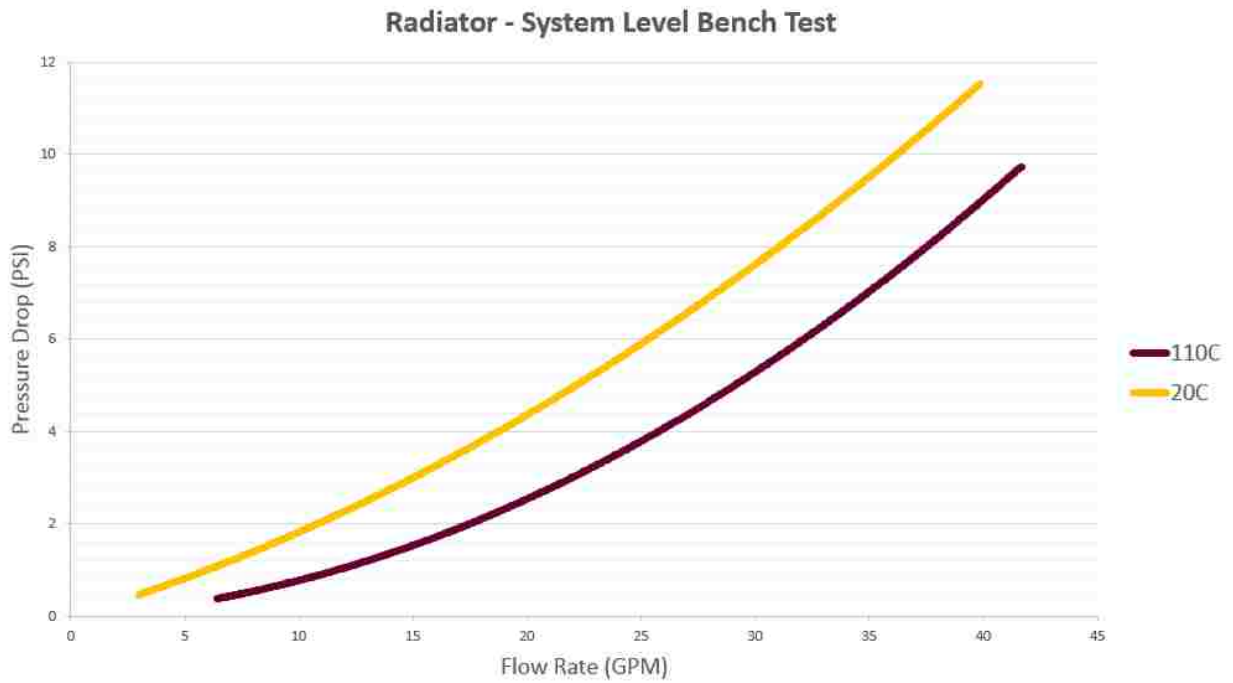

Figure 3. 34 – Radiator data collected on the system level flow bench, open thermostat.

## 4. Component Level Investigation

Component level models are built in GT-SUITE with the geometry and performance data provided by the supplier. A calibrated component then performs as per the supplier data in a virtual environment. For each heat exchanger, two sections exist, one master side and one slave side. Each side represents a specific fluid, providing the ability to model flow of each fluid through a geometric structure and if desired the exchange of heat between the fluids. For the purpose of this project, the focus is strictly on the coolant flow side and geometry of coolant flow passages. Therefore, heat transfer was not modelled. For the coolant side of each heat exchanger, 50-50 ethylene-glycol coolant composition is chosen from the fluid library and all appropriate fluid properties are imposed based on this selection. Once the necessary geometry and performance data is gathered and input to each component model, a Case Setup is used to impose coolant flow rate at the inlet of the part and coolant inlet flow temperature is set as a boundary condition. The results from running these cases are then compared to performance data, either from a supplier or experimental flow bench, and the model set up can be calibrated as necessary to achieve accurate correlation.

In most instances, the geometry and performance data provided by suppliers is insufficient or sometimes nonexistent. Furthermore, the supplier data that is available is limited with regards to temperature range and water pump/engine RPM range. This is where the use of the single component flow bench provides significant advantage in the modelling process. In addition, the geometry inputs which GT-SUITE requires to accurately represent and model the flow passages on either side of a heat exchanger far exceed those quantities which are provided by the supplier. Therefore, a detailed investigation was done by physically dissecting each heat exchanger to better understand the internal geometry and collect the necessary inputs to satisfy the 1D model build.

This chapter will cover the detailed work done to investigate and model the heat exchangers, the hot bottle and pump, all of which make up the component library of this engine cooling system.

#### 4.1 Radiator and Heater Core

The radiator and heater core were modelled using the same approach, as they are both tube and fin heat exchangers which exercise coolant flow through one section and air flow through the other for a means of exchanging heat. Both sides have an inlet and outlet environment, with flow imposed at the inlet using the Case Setup. The air side of these models is represented using ambient boundary conditions with a negligible inlet air flow rate. The coolant side of these models is represented using the Case Setup to input coolant temperature and a range of flow rates. Figure 4.1 shows the radiator 1D model icon, coolant and air side, with the respective inlet and outlet for each.

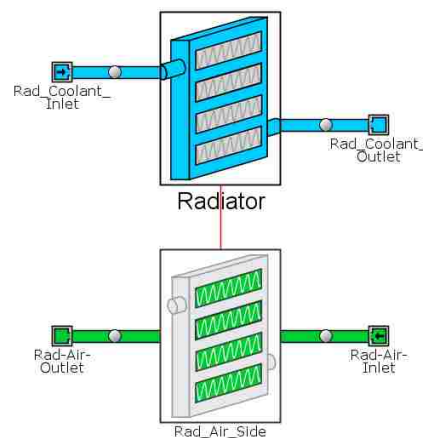

*Figure 4. 1 – 1D radiator component model.*

The number of geometry inputs required to build the 1D component model is significant, and they are listed below (Table 4.1). Since the majority of these inputs were not provided by the supplier, the radiator and heater core were carefully dissected (Figure 4.2) to gain insight into the geometry and internal flow passages, to better understand the flow behaviour and adequately build the model. After running the model, pressure drop and flow rate data was extracted from the post processing interface, GT-POST. The model data was correlated with the single component bench data for validation (Figure 4.3). The following inputs were found to have the greatest effect on model correlation:

- The input of total heat exchanger depth and number of rows of tubes
- The input of tank volume and orientation

Table 4. 1 – Radiator/heater core model inputs.

Heat exchanger height	Heat exchanger width
Total heat exchanger depth	Major/minor channel dimension
Internal flow orientation	Dry mass of heat exchanger
Inlet connection diameter	Outlet connection diameter
Heat exchanger material	Tank width
Tank width	Tank volume
Number of rows of tubes	Tube wall thickness
Fin pitch	Fin thickness



Figure 4. 2 – Dissected radiator and heater core for detailed geometry investigation.

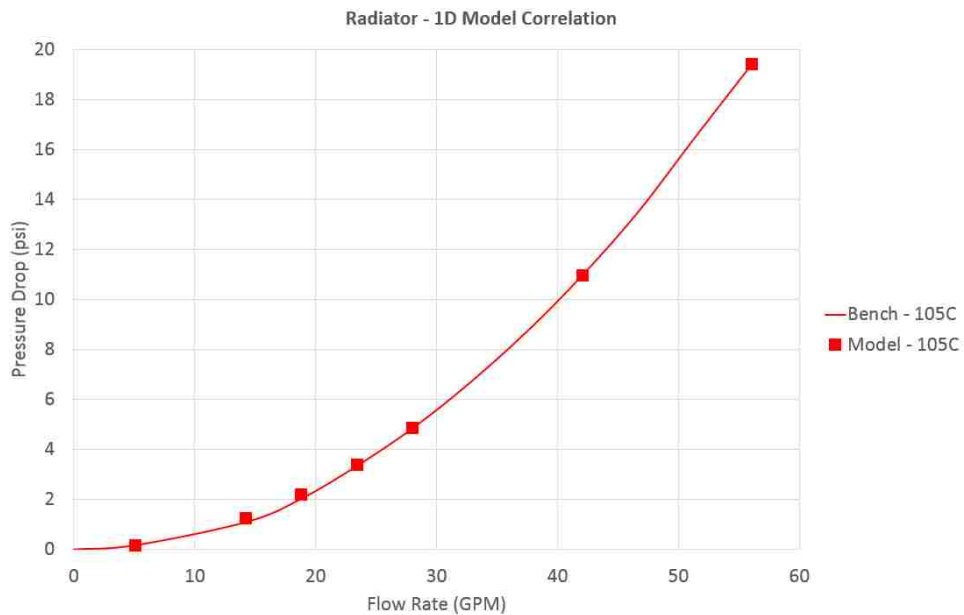

Figure 4. 3 – Radiator component bench data to model correlation.

## 4.2 Engine Oil Cooler and Transmission Oil Heater

The engine oil cooler and transmission oil heater were modelled using the same approach, as they are both plate and fin heat exchangers which exercise coolant flow through one section and oil flow through the other as a means of exchanging heat. Like the radiator and heater core, both sides have an inlet and outlet environment, with flow imposed at the inlet using the Case Setup. The oil side of these models is represented using ambient boundary conditions with a negligible inlet oil flow rate. The coolant side of these models is represented using the Case Setup to input coolant temperature and a range of flow rates. Figure 4.4 shows the TOH 1D model icon, coolant and oil side, with the respective inlet and outlet for each.

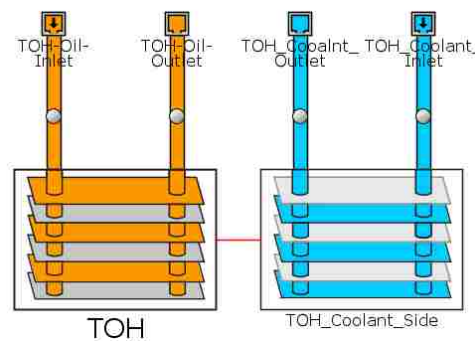

Figure 4. 4 – 1D TOH component model.

The number of geometry inputs required to build the 1D component model was significant, and they are listed below (Table 4.2). None of these inputs were provided by the supplier and so the EOC and TOH were carefully dissected (Figure 4.5) to gain insight into the geometry and internal flow passages, to better understand the flow behaviour and adequately build the model.

After running the model, pressure drop and flow rate data was extracted from the post processing interface, GT-POST. The model data was correlated with the single component bench data for validation (Figure 4.6). The following inputs were found to have the greatest effect on model correlation:

- The appropriate selection of each fluid and their respective properties
- The input of plate dimensions and relative inlet locations (i.e. same side vs. opposite side)



Table 4. 2 – Oil cooler/heater model inputs.

Plate length	Plate width
Plate thickness	Connection diameters
Channel height	Number of channels
Number of passes	First channel fluid
Relative inlet locations	Number of baffles
Dry mass of heat exchanger	Heat exchanger material



Figure 4. 5 – Dissected TOH for detailed geometry investigation.

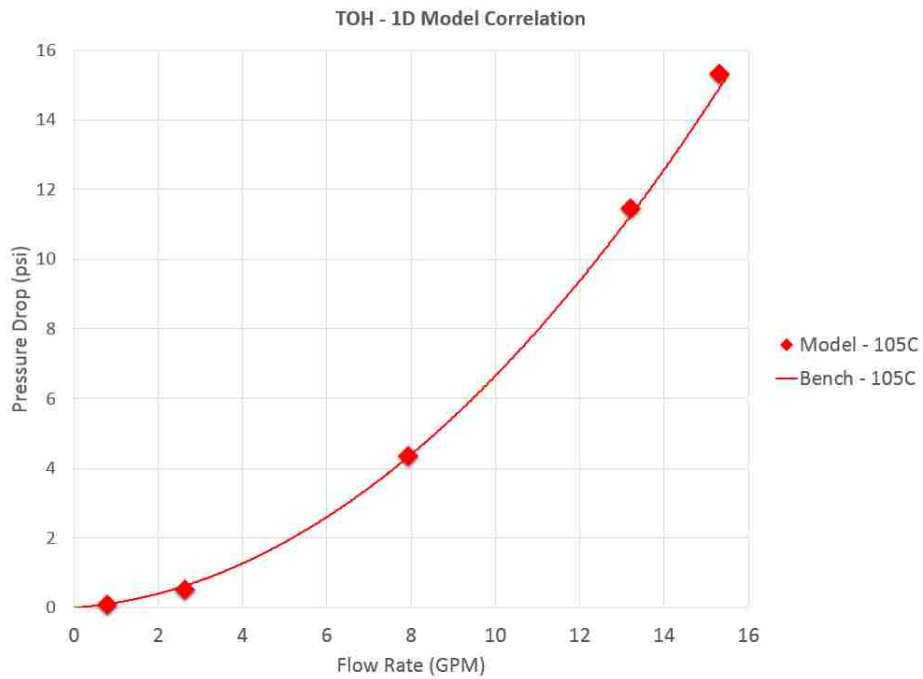
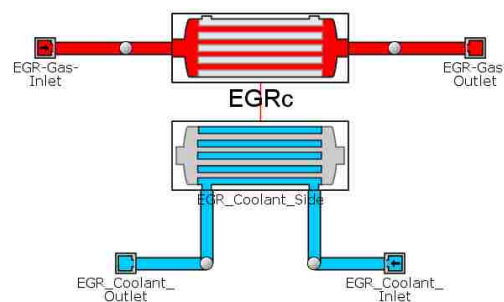

Figure 4. 6 – TOH component bench data to model correlation.

### 4.3 Exhaust Gas Recirculation Cooler

The exhaust gas recirculation cooler was modelled using the shell and tube template, which exercise coolant flow through one section and exhaust gas flow through the other for a means of exchanging heat. Both sides have an inlet and outlet environment, with flow imposed at the inlet using the Case Setup. The exhaust gas side of these models is represented using ambient boundary conditions with a negligible inlet gas flow rate. The coolant side of this model is represented using the Case Setup to input coolant temperature and a range of flow rates. Figure 4.7 shows the EGRc 1D model icon, coolant and gas side, with the respective inlet and outlet for each.



*Figure 4. 7 – 1D EGRc component model.*

The number of geometry inputs required to build the 1D component model was significant, and they are listed below (Table 4.3). None of these inputs were provided by the supplier and so the EGRc was carefully dissected (Figure 4.8) to gain insight into the geometry and internal flow passages, to better understand the flow behaviour and adequately build the model.

After running the model, pressure drop and flow rate data was extracted from the post processing interface, GT-POST. The model data was correlated with the single component bench data for validation (Figure 4.9). The following inputs were found to have the greatest effect on model correlation:

- The appropriate selection of each fluid and their respective properties
- The input of channel dimensions and shell diameter

Table 4. 3 – EGRc model inputs.

Tube Length	Tube wall thickness
Number of channels	Major/minor channel dimension
Inlet tank volume	Outlet tank volume
Inlet connection diameter	Outlet connection diameter
Heat exchanger material	Dry mass of heat exchanger
Shell diameter	Relative inlet locations



Figure 4. 8 – Dissected EGRc for detailed geometry investigation.

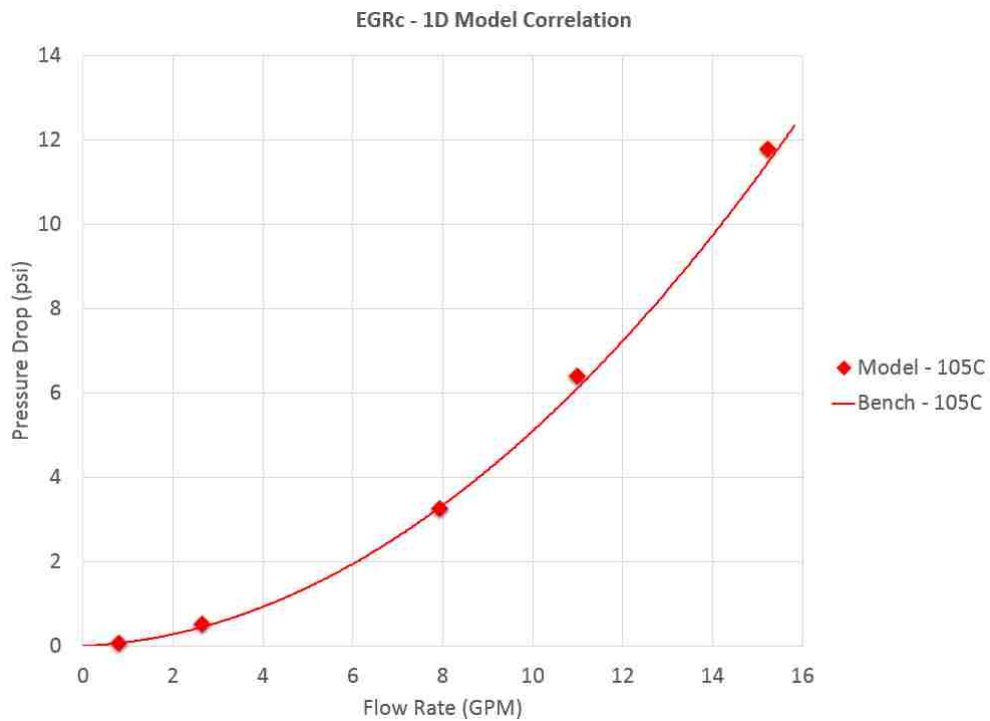

Figure 4. 9 – EGRc component bench data to model correlation.

#### 4.4 Hot Bottle

The hot bottle was modelled using an accumulator template, which assists with the pressure regulation of the system, and a relief cap which allows air to escape in high pressure situations. As heat is generated in an engine cooling system, the liquid coolant inside the hot bottle will expand, and this model can be used to keep the system pressure in control. The coolant side has an inlet and outlet environment, with flow imposed at the inlet using the Case Setup. The coolant side of this model is represented using the Case Setup to input coolant temperature and a range of flow rates. Figure 4.10 shows the bottle 1D model icon, coolant side with inlet and outlet, and air side with outlet pressure relief from the cap.

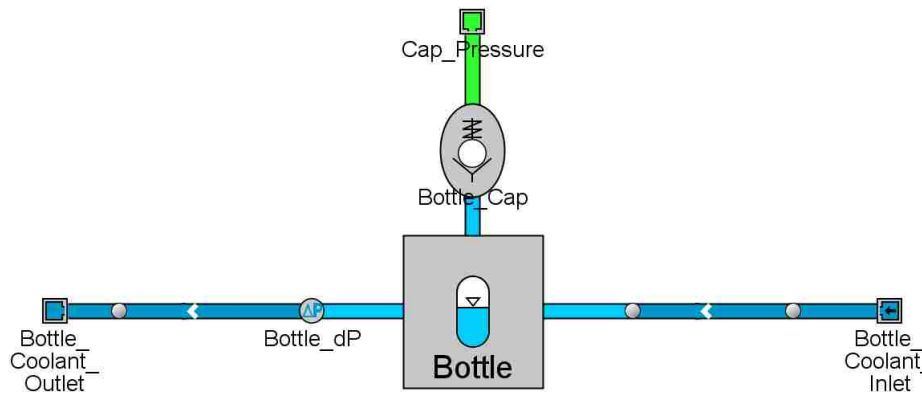

Figure 4. 10 – 1D hot bottle component model.

There were a number of inputs required to build the 1D component model of the hot bottle, and they are listed below (Table 4.4). The CAD geometry of the bottle was analyzed (Figure 4.11) and used to gain insight into the geometry and internal flow passages, to better understand the flow behaviour and adequately build the model. The bottle cap is modeled as a simple check valve, defined such that high pressure at the inlet causes the valve to open. Unlike the previous components, the hot bottle contains two fluids in one common section, and it is important to initialize the properties and states of both the coolant and air in the model.

Table 4. 4 – Hot bottle model inputs.

Fluid 1 initial state	Fluid 2 initial state
Fluid 1 initial volume	Total volume
Valve diameter	Valve lift time constant



Figure 4.11 – Dissected bottle CAD for detailed geometry investigation.

After running the model, pressure drop and flow rate data was extracted from the post processing interface, GT-POST. The model data was correlated with the bench data for validation (Figure 4.12). The following inputs were found to have the greatest effect on model correlation:

- The correspondence of connection ports to the appropriate fluid is critical to the solver performing accurately
- Time constant of the check valve implicitly defines inertia of the valve closing, which may allow reverse flow to occur

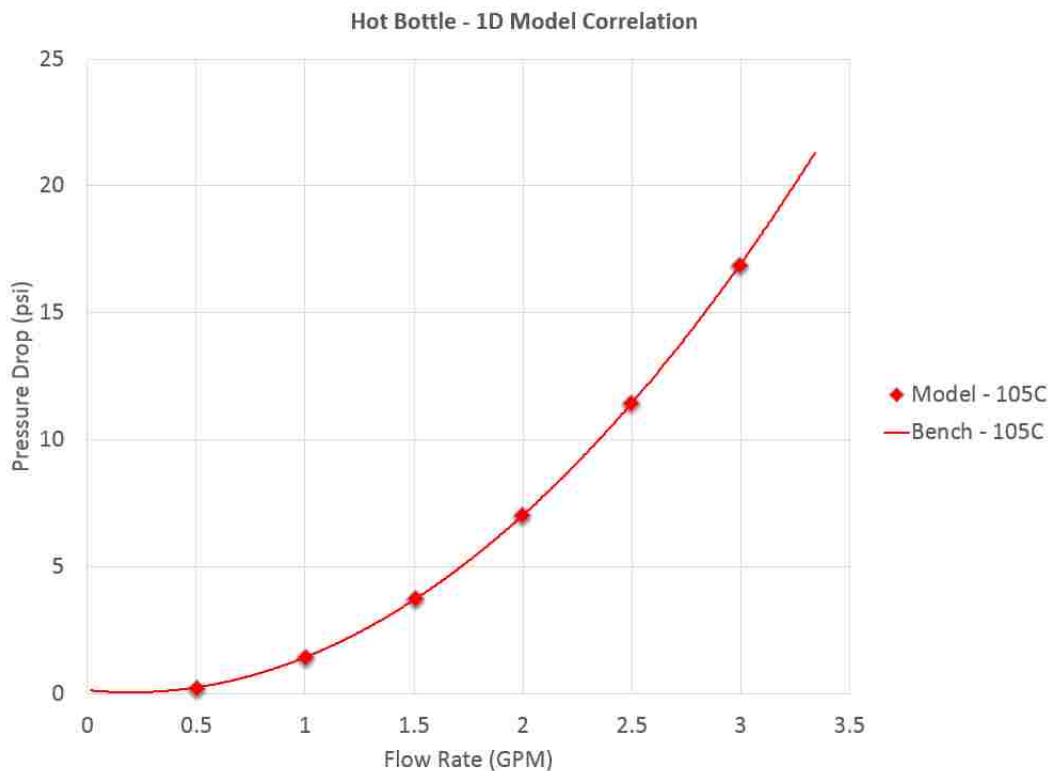
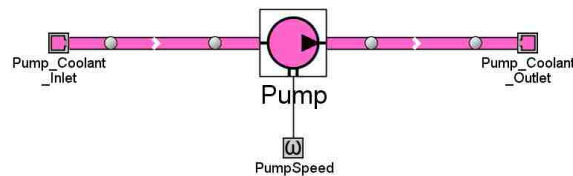

Figure 4.12 – Hot bottle component bench data to model correlation.

## 4.5 Water Pump

The water pump was modelled using a pump template, which is built based on measured performance data that correlates pump speed, flow rate, pressure rise and total efficiency. Figure 4.13 shows the pump icon, including the speed input and coolant inlet/outlet ends. This component investigation differs from the previous based on the following stipulations:

- flow is not imposed at the inlet connection
- neither the physical part nor CAD were used for dissection



*Figure 4. 13 – 1D pump component model.*

Instead, flow is imposed based on the pump speed which is input as a range within the Case Setup. The inlet and outlet end environments are the locations where the fluid state is input, in this instance coolant properties and temperature at which the pump is being evaluated. For this component, supplier data was available and included pump speed, volumetric flow rate, pressure rise, temperature and total isentropic efficiency. The efficiency value is used within the system simulation software to calculate the power required for the pump and will also affect the outlet temperature. Based on the pre-process pump map, the solver looks up the flow rate and efficiency for that speed and pressure rise, and the flow rate is then imposed directly on the flow boundaries of the pump.

After running the model, pressure rise and flow rate data was extracted from the post processing interface, GT-POST. The model data was correlated with the supplier data for validation (Figure 4.14). The following inputs were found to have the greatest effect on model correlation:

- The pre-process map needs to cover the full range of speeds used during simulation
- Implicit solver produces more robust results, albeit with slower converge time, by using multiple pump maps (at varying temperatures)

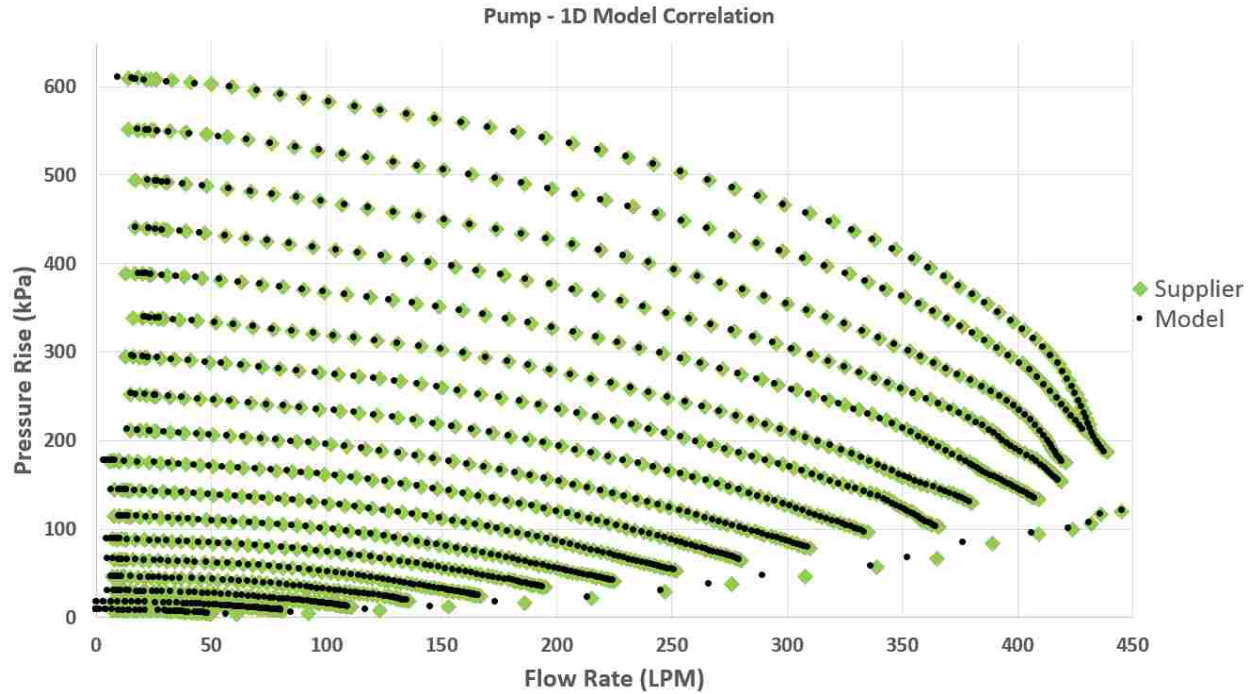

Figure 4. 14 – Pump component supplier data to model correlation.

#### 4.6 Component Summary

By completing the detailed physical investigation and 1D simulation of each of these components, each component model can confidently be used in the system level model. Furthermore, by determining the key inputs which affect model correlation, component models can be used in the future to model changes in geometry and performance data, before the part is available for testing or dissection. Although physical dissection is not always practical, by having completed the dissections for this project the critical geometry inputs are now known and can be requested from suppliers in anticipation of modelling future components.

## 5. System Level Investigation

After completing the component level investigation for each heat exchanger, the hot bottle and pump, the next step is to move onto investigating and modelling the interaction of all these components as a system. It is important to note again that for this project only the coolant side of each heat exchanger was considered in the system level model, in order to establish confidence in modelling the coolant flow of an adiabatic circuit. System simulation is capable of modelling a variety of vehicle-related flow systems, and by first achieving correlation for the coolant loop, other models can be reliably linked in subsequent design stages to include heat transfer and other phenomena.

When an engine is started in a vehicle, coolant is initially propelled through the engine's water jacket, by a pump mounted to the engine front cover. As the coolant returns from the water jacket, it passes over a thermostat control valve that will open if the coolant has reached the desired operating temperature and initiate (or increase) flow to the heat exchangers. The ultimate goal is to ensure that adequate coolant flow is achieved through all system plumbing and components to effectively operate a vehicle under any condition.

This chapter describes the use of a GT-SUITE preprocessing tool, GEM3D, to interpret, convert, and incorporate 3D CAD geometry into the 1D platform. This tool was used on all plumbing lines, the thermostat and bypass flow splits, and water jacket geometry. In addition, the use of 3D CFD results provided by FCA is highlighted as a means for correlating system level results where no supplier data is available, particularly for the water jacket and thermostat networks. Ultimately, the process for combining all components into an accurate and validated 1D system level model is explained in detail.



## 5.1 Plumbing

A network of plumbing lines is essential to complete the coolant loop of an engine cooling system. The layout of these lines is governed by the location of each component relative to the engine and available under hood space in a vehicle. Table 5.1 gives an itemized list of plumbing branches which were required to complete the engine cooling system model:

*Table 5. 1 – List of coolant loop plumbing lines.*

Radiator inlet line	Radiator outlet line
Heater core inlet line	Heater core outlet line
TOH inlet line	TOH outlet line
EGR inlet line	EGR outlet line
Pump inlet line	EOC outlet line

In general, each component has one inlet line and one outlet line which carry coolant over a given distance to and from the engine. The exceptions are two engine mounted components, the EOC which receives coolant directly from ports on the engine block, and the pump which supplies coolant directly into the engine block. Discretizing the plumbing network is a necessary first step to converting the complicated geometry into individual flow components that the 1D software is capable of modelling. The two conversion objects that are used to go from a 3D shape to a 1D component are pipe and flow split, and their respective subcategories are listed below:

### Pipes:

- Straight
- Single bend
- Multi bend

### Flow splits:

- T split
- Y split
- General

A general flow split is any flow component with multiple inlets and/or outlets that does not qualify as a T or Y shape. A plane was used to manipulate the cutting location in a specific direction or orientation along each plumbing line to create either a pipe or flow split shape. The cutting plane indicates the range of bend angle when virtually dragged along each section of 3D geometry, as shown in Figure 5.1. This cutting plane was used to judge the best location for

discretizing each 3D shape, by indicating the location at which minimal change in cross sectional area and bend angle occurs.

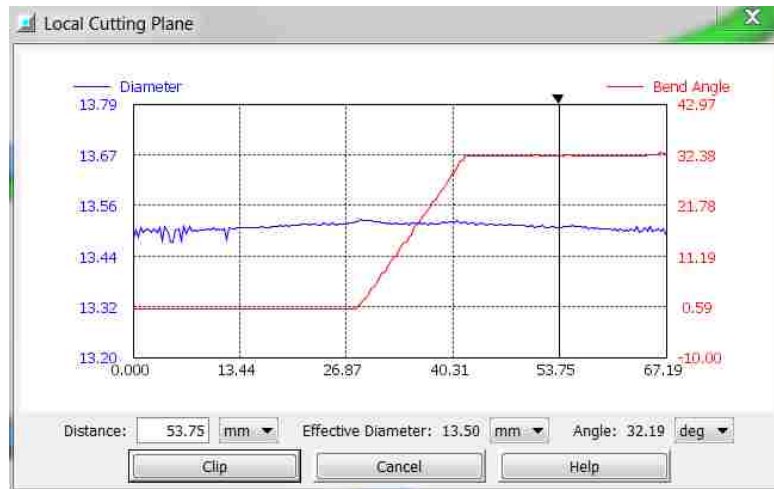

Figure 5.1 – Cutting plane location diameter and bend angle.

Prior to accepting the conversion to a 1D component based on the clips made with a cutting plane, a number of inputs need to be confirmed for each pipe or flow split shape. Some of these, such as diameter and wall thickness, should be correctly derived from the sophisticated software, but others like surface finish and initial state need to be designated. The full list of inputs for each 3D shape are listed below in Table 5.2.

Table 5. 2 – 3D to 1D conversion inputs.

Wall thickness	Surface finish
Port diameters	Expansion diameters
Initial state	Discretization length
Boundary locations	Characteristic length

As each line was clipped, the individual sections were named based on the component line each corresponds to and which direction that line is oriented. For example, a straight pipe section of the TOH supply line was labeled TOH\_P\_S\_1 (P for pipe, S for supply), for ease of organization and orientation within the 1D model map. Figure 5.2 shows the GEM3D model for the plumbing

circuit, after each set of plumbing lines has been meticulously cut and converted to individual flow components.

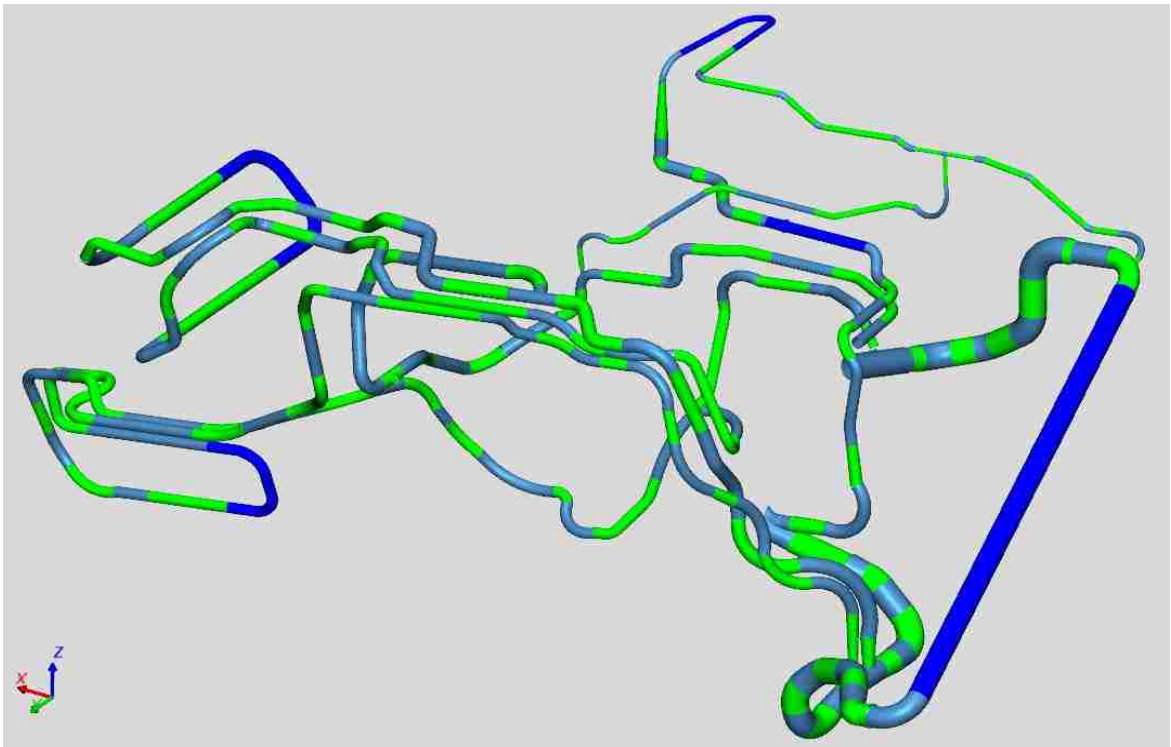
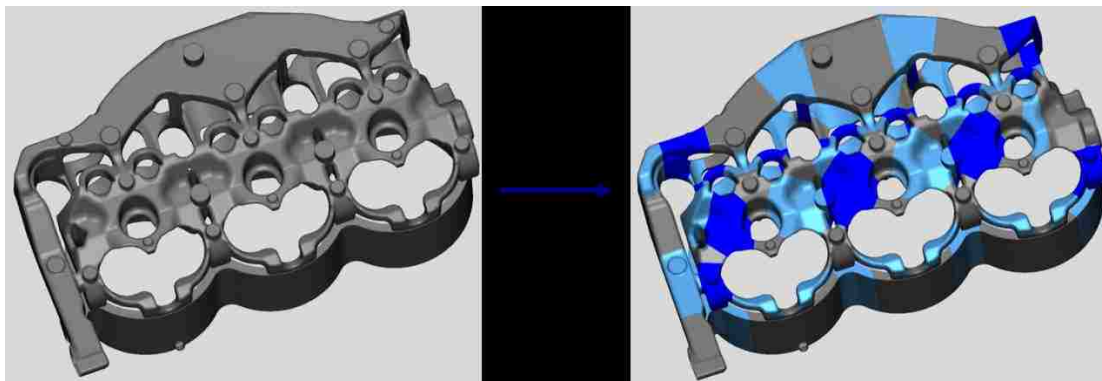

*Figure 5. 2 – Discretized coolant loop plumbing.*

Over 400 individual 1D components were identified when this geometry was exported to GT-SUITE. Note that the dark blue segments in Figure 5.2 are not flow components that would be found in the cooling system, but rather are place holders for a component to be inserted. These are used to first ensure coolant is flowing through all branches before incorporating heat exchangers and other single component models. Similar to the process of running a single component simulation, flow was imposed at the inlet location (where the pump would eventually go) to this network of plumbing flow components, and outlet boundaries were designated where the water jacket would eventually go. Once coolant flow was established through the entire plumbing network, components could be added to complete the system 1D system model.

## 5.2 Water Jacket Study

Extremely high temperatures are generated inside the engine of a vehicle during fuel combustion. A substantial amount of this heat is transferred to the cylinder block, head, pistons and valves. Without an engine cooling water jacket, material properties of these parts and the lubricant oil would degrade and damage or failure could occur. Capturing the coolant flow phenomena inside the water jacket poses a significant challenge because, unlike the plumbing lines in the previous section, the passages are not composed of simple one-inlet-one-outlet pipes or flow splits. Instead, there exists a complicated network of very intricate flow splits. The water jacket includes passages through the cylinder block and head, connected via gasket holes, with inlet flow from the pump, and outlet flow to the engine cooling system.



*Figure 5.3 – Discretized water jacket.*

Figure 5.3 shows the water jacket mesh before and after being discretized into many 3D flow splits, which were ultimately converted into 1D flow components.

### 5.2.1 Water Jacket Data

Existing CFD results were provided by FCA, specific to this engine cooling system, from a steady state simulation of coolant flow through the water jacket at 105°C. In general, CFD simulations are time consuming and limited to one condition, whereas 1D simulations are quick and capable of simulating transient drive cycles, as well as other drive cycles. The locations at which data was taken from the CFD results are illustrated in Figure 5.4 (circled in red), corresponding closely to the locations of detailed instrumentation for the water jacket (see Figures 3.22, 3.23 & 3.24) used on the system level flow bench.

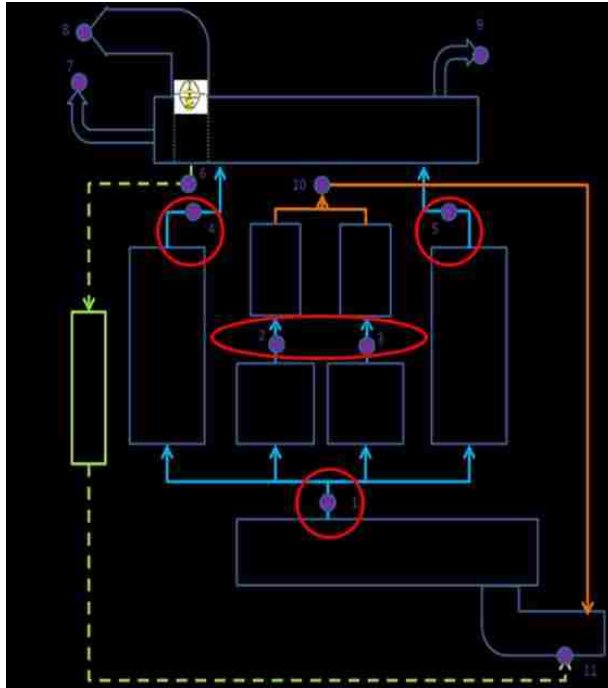

Figure 5. 4 – Water jacket CFD result schematic.

By using the corresponding water jacket layout in Figure 5.5, pressure and flow data was considered at five key points:

- Pump Outlet (1)
- Block Outlets to EOC (2 & 3)
- Head Outlets (4 & 5)

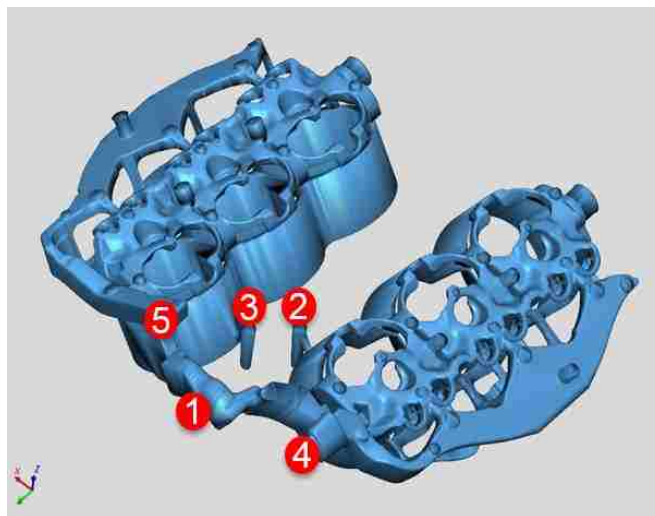

Figure 5. 5 – Water jacket geometry with data locations.

In locations where it was not feasible to embed flow meters on the flow bench, such as the pump outlet/water jacket inlet, calculations were done to deduce the flow rate based on locations where data collection was achievable. Thus to calculate the pump out flow rate, the following formula was used:

$$\text{Pump flow} =$$

$$\text{radiator flow} + \text{heater core flow} + \text{TOH flow} + \text{EOC flow} + \text{EGRc flow} + \text{hot bottle flow}$$

### 5.2.2 Water Jacket Geometry

The complex 3D water jacket geometry and flow pattern must be represented in the 1D simulation software. A distinct cutting plane was used at numerous locations to create flow splits with multiple inlets and multiple outlets. Figure 5.6 shows the opaque cutting plane with its coordinates relative to the water jacket mesh, and the GEM3D control window which facilitated the manipulation of each clip location.

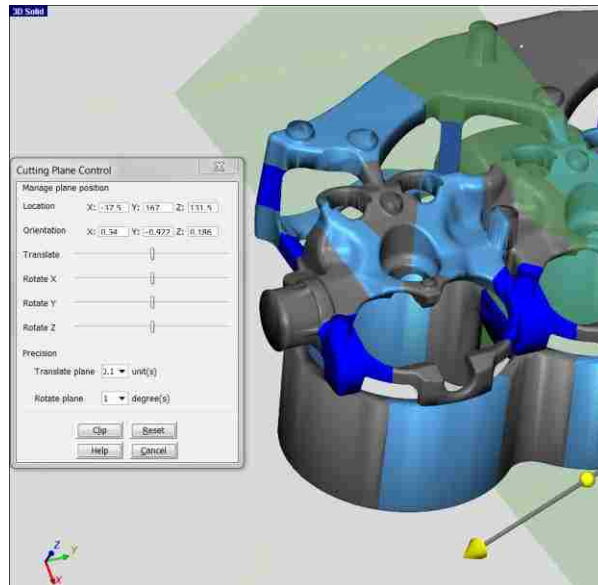

Figure 5. 6 – Flow split cutting plane.

Best efforts were made to choose cutting locations at areas with minimal abrupt change in cross-sectional area. In addition, it was important to be aware of the flow split shapes that were being created and whether they properly represent and follow the coolant flow path. In order to organize and efficiently track the flow splits being created, the block and head were discretized

as separate subassemblies within GEM3D. Figure 5.7 shows the flow splits for the block subassembly. Once each flow split is created, GEM3D requires the user to designate a “port hole” number at each inlet and outlet. These numbers are important as they identify the location at which the coolant will enter into the flow split and where it will exit into the adjacent flow split(s). In the case of Figure 5.8, coolant flow enters at port hole 1, partial flow exits at port hole 2, and the remaining flow exits at port hole 3. Designating and labelling these was essential to tracking and investigating the coolant flow in post processing once the flow splits are exported to GT-SUITE as 1D components (for example, ensuring the summation of flow leaving port holes 2 and 3 is equal to the flow rate entering port hole 1).

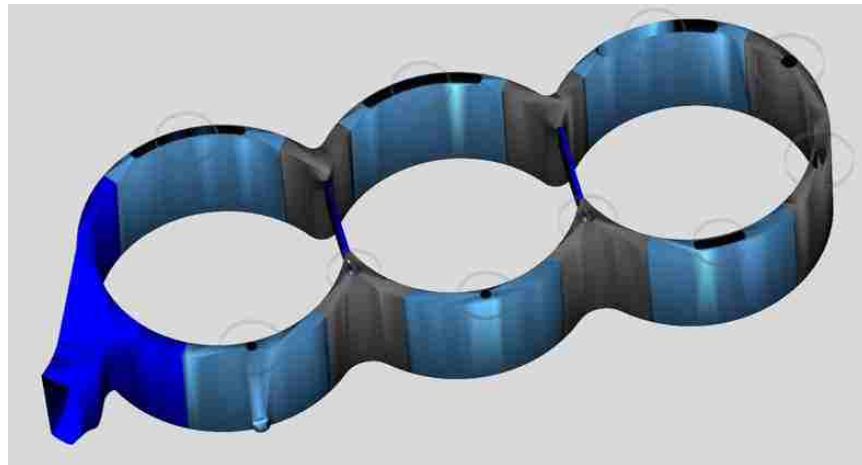

Figure 5. 7 – Cylinder block flow splits.

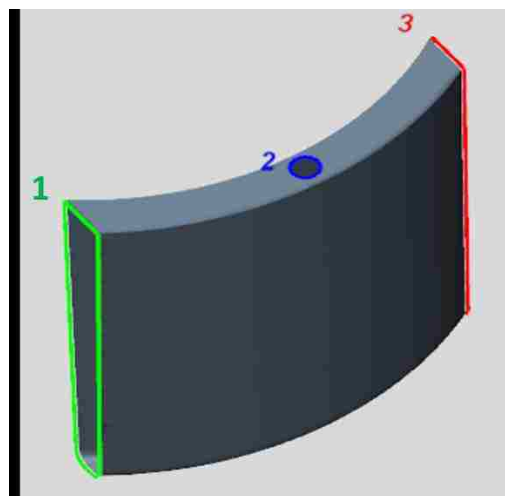
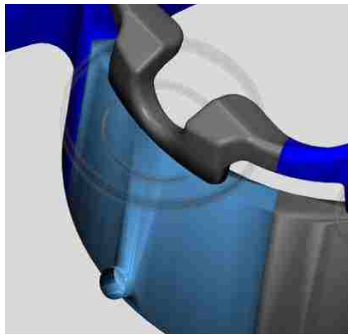
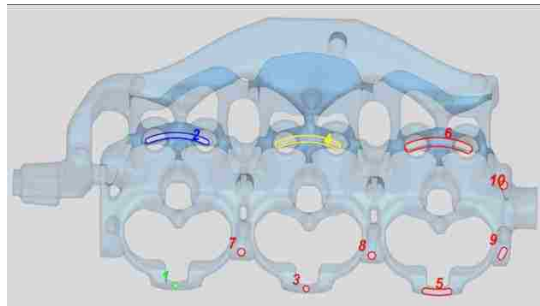

Figure 5. 8 – Port hole numbering in GEM3D.

Of particular significance are the port holes that are also gasket holes. Within the GEM3D software, these were specifically designated as “external connections”, meaning that after the flow split is created and port holes are numbered, these holes are separately distinguished to serve as a connection between subassemblies and indicated by the ring structures surrounding the area where the gasket holes are hidden (Figure 5.9). A nomenclature was established to track the gasket hole locations (Figures 5.10 & 5.11). For example, the right side head gasket hole 2 port was named Gas\_RH\_2 (gas for gasket, R for right, H for head). This was key to lining up and connecting the block and head subassemblies, and provides a clear reference for flow and pressure data during post processing.



*Figure 5. 9 – Gasket hole connection between block and head flow splits.*



*Figure 5. 10 – Gasket hole numbering on head subassembly.*

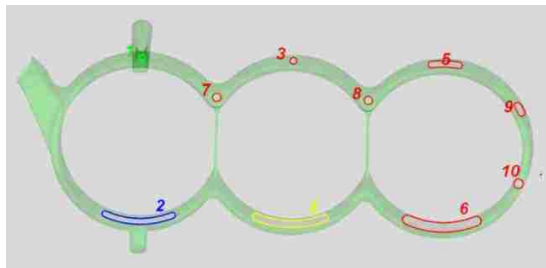

*Figure 5. 11 – Gasket hole numbering on block subassembly.*



### 5.2.3 Water Jacket 1D Model

The 3D flow splits for the water jacket were exported to GT-SUITE, creating the head 1D model (Figure 5.12) and block 1D model (Figure 5.13) subassemblies. These figures display a screenshot of the 3D flow splits (in grey and blue) imposed below the corresponding 1D network (in pink) to give a visual of how the two modelling phases align. The link between each flow split that GT-SUITE created during the import process was checked to ensure the correct flow direction was imposed, and all critical points for data input and processing (inlets, outlets, gasket holes) were verified and organized.

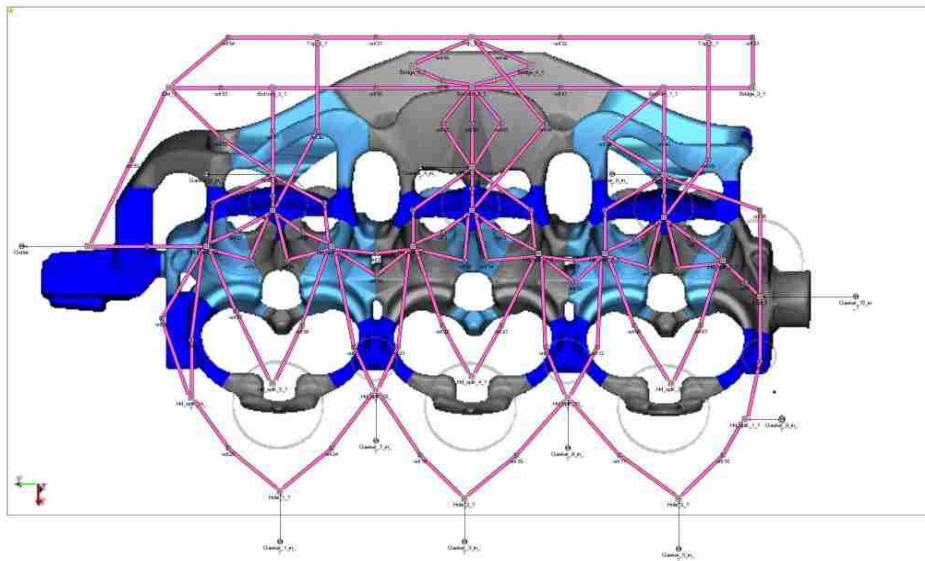

Figure 5. 12 – Head subassembly 1D model.

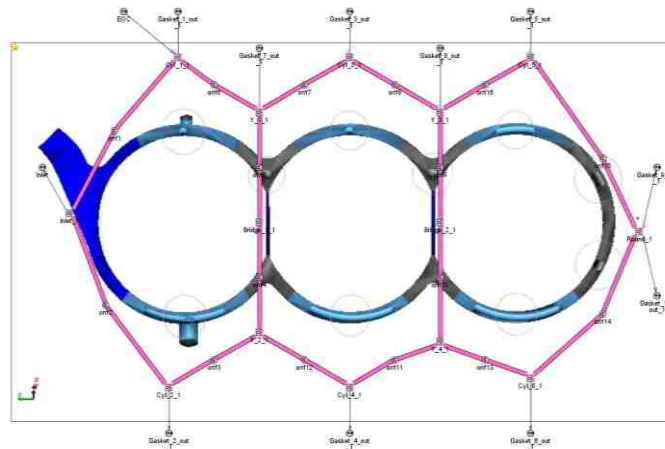

Figure 5. 13 – Block subassembly 1D model.

To create the full water jacket 1D model, each subassembly was imported into one common file where the individual head and block gasket hole connections that were established earlier serve to connect the block and head files. Similar to the approach used in single component modelling, flow was imposed at the inlet to the water jacket, and outlet boundaries were designated at each of the left and right, head and block outlets. The complete water jacket model, pictured in Figure 5.14, consists of the following elements:

- Left head subassembly
- Left block subassembly
- Right head subassembly
- Right block subassembly
- 20 gasket hole connections
- 1 inlet from pump
- Left head outlet
- Right head outlet
- Left block outlet
- Right block outlet

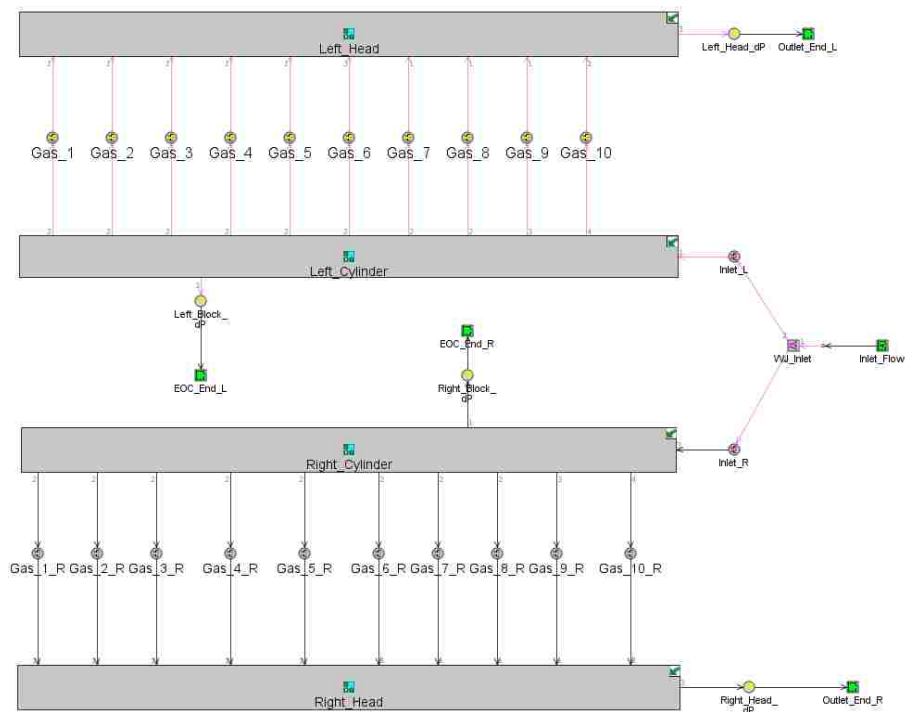
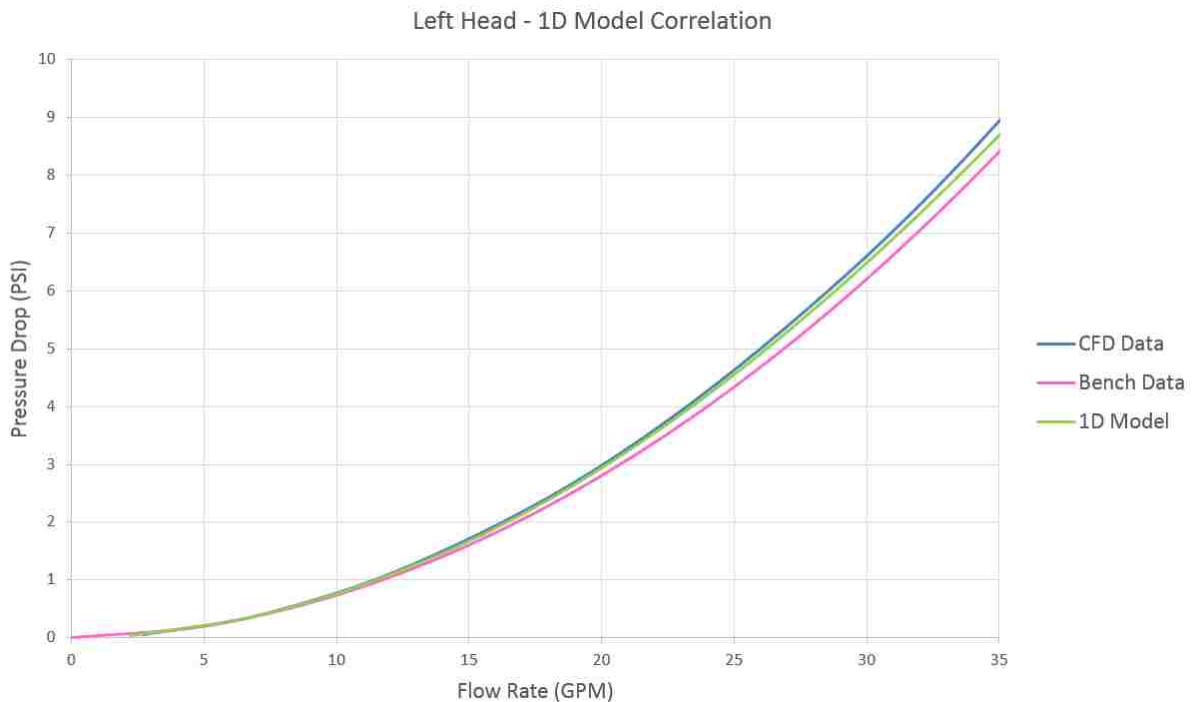

Figure 5. 14 – Complete water jacket 1D model.

To run the water jacket model, the pump flow that was calculated from the system bench data, or the pump flow data from the CFD results, can be imposed at the water jacket inlet using the case setp in GT-SUITE. The resulting pressure drop data from the head and block outlets was collected and compared to the CFD results and bench data (Figure 5.15). Coolant temperature and boundary temperatures were found to have a significant effect on model correlation. It was also critical to analyze the result files for each subassembly individually to effectively iterate the complete water jacket model assembly.



*Figure 5. 15 – Left head 1D model correlation.*

One of the significant outcomes from this modelling approach is the ability to investigate the flow and pressure, not only at the outlet(s), but also at the internal flow splits and connections. For example, for the water jacket, the gasket hole connections with flow rate through each are displayed in Figure 5.16, in gallons per minute, from the GT-POST interface. Furthermore, each subassembly (block or head) can be opened to give designers and engineers a better insight into the flow behaviour at very specific locations (i.e. middle of the block, end of the head, across a

specific gasket hole etc.) for a number of parameters such as pressure drop, volumetric flow rate, coolant temperature, wall temperature, and Reynolds number.

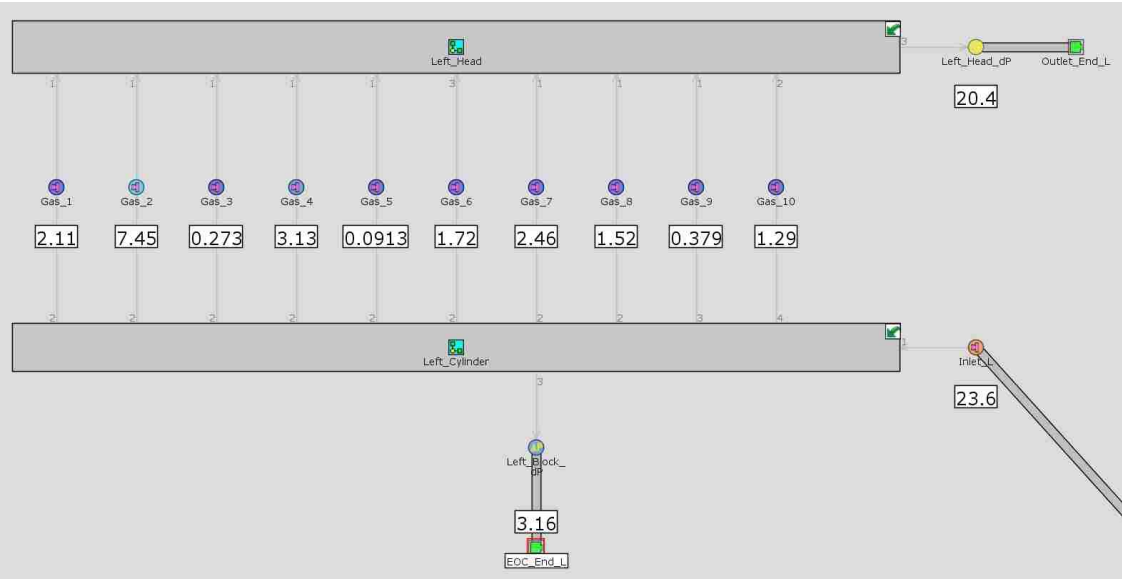

Figure 5. 16 – Gasket hole flow rate results.



there is a linear relationship between the partial opening conditions for each lift position in between closed and fully open (Table 5.3).

*Table 5. 3 – Thermostat vs. bypass lift values.*

<b>Thermostat Lift (mm)</b>	<b>Bypass Lift (mm)</b>
0	8
2	6
4	4
6	2
8	0

Using the same process that was described for the plumbing and water jacket geometry, GEM3D was used to extract the flow split geometry for each thermostat housing and bypass gallery and these were exported as a 1D flow component into GT-SUITE. Here the thermostat was connected with outlets from the water jacket, leading to the heat exchangers and the bypass (Figure 5.18). The values from Table 5.3 were input to the thermostat and bypass valve components of the 1D model, and the lift value is imposed from the case set up of the run procedure. GT-SUITE performs an area calculation based on this imposed lift, which ultimately dictates the amount of coolant flow through either the thermostat or bypass, or both. For this project, data was collected on the system level flow bench with the thermostat mechanically opened, and mechanically closed. Therefore, the model inputs for thermostat lift were either 8 mm (open) or 0 mm (closed), to achieve correlation at results which match available bench and CFD results. Figure 5.19 shows the correlation that was achieved based on the imposed inlet flow from the water jacket and pressure drop data attained from GT-POST at the exiting branches, in this case the bypass.

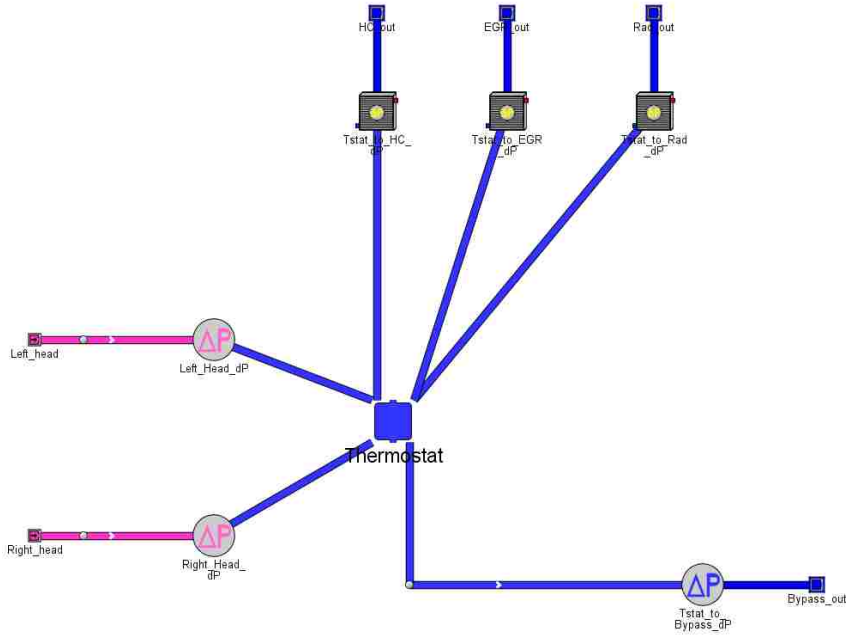

Figure 5. 18 – 1D thermostat model.

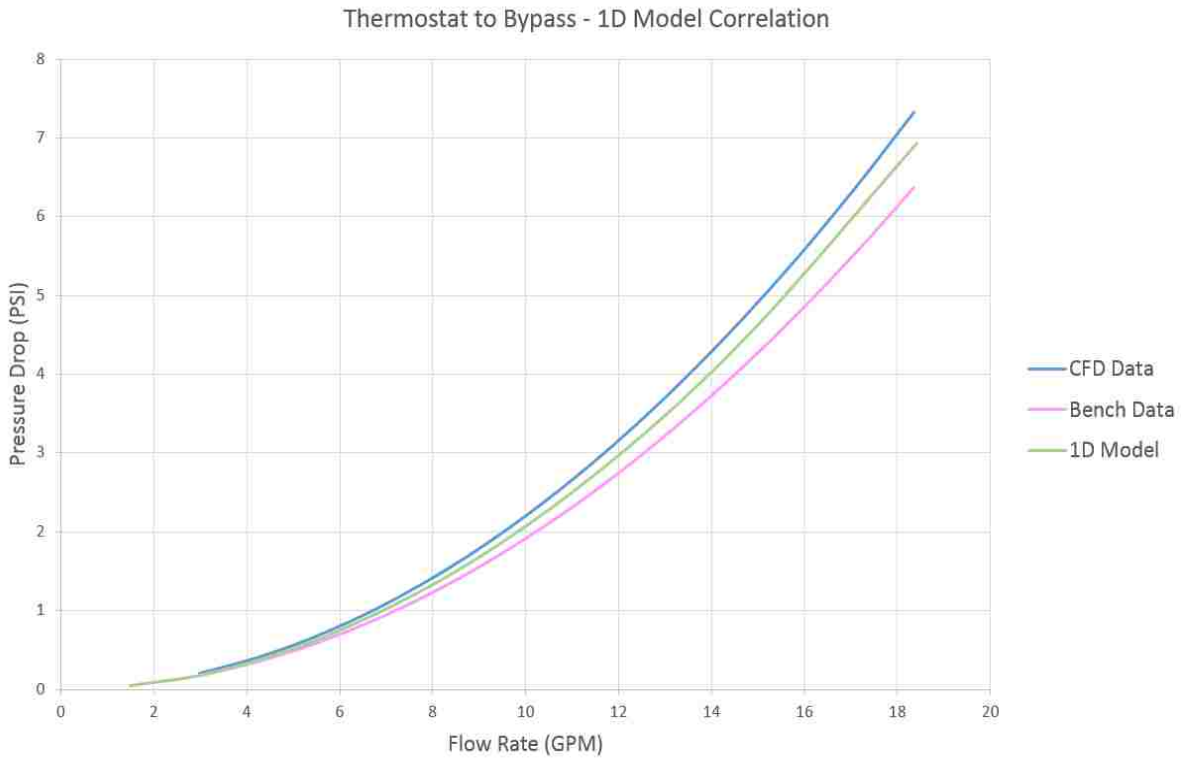

Figure 5. 19 – Thermostat closed 1D model correlation.

#### 5.4 System Model Build

The first step to building the system level model is to bring all the component level models together into one common GT-SUITE file. The pipes/bends which were used as place holders for heat exchangers, as referred to in Section 5.1, were removed, as were the inlet and outlet boundaries of single components, because this is where the plumbing could then be connected to each component. The full list of components which are combined to create the system model is given below:

- Radiator, heater core, TOH, EOC and EGRc (coolant side only)
- Hot bottle
- Pump
- Plumbing network
- Thermostat
- Water jacket assembly

Figure 5.20 shows the complete system model with a “flow component” view, displaying individual icons for each plumbing flow split as well as components. Figure 5.21 shows the complete system model with a “pipe” view, which smooths over the individual icons for each plumbing flow split to create a more refined view. These figures represent the same model from different perspectives.

Before the system simulation can run, it is critical to ensure a common “fluid object” is defined and input for all components. Although each separate model would have been designated with a 50-50 ethylene glycol (coolant) fluid object from the fluid library, the nomenclature and initial conditions for each may vary based on the available data and/or Case Setup for that individual model. Upon compiling the system model, a new common fluid object was defined and designated to all system components, which allows for temperature input in the Case Setup to be applied across the entire system.



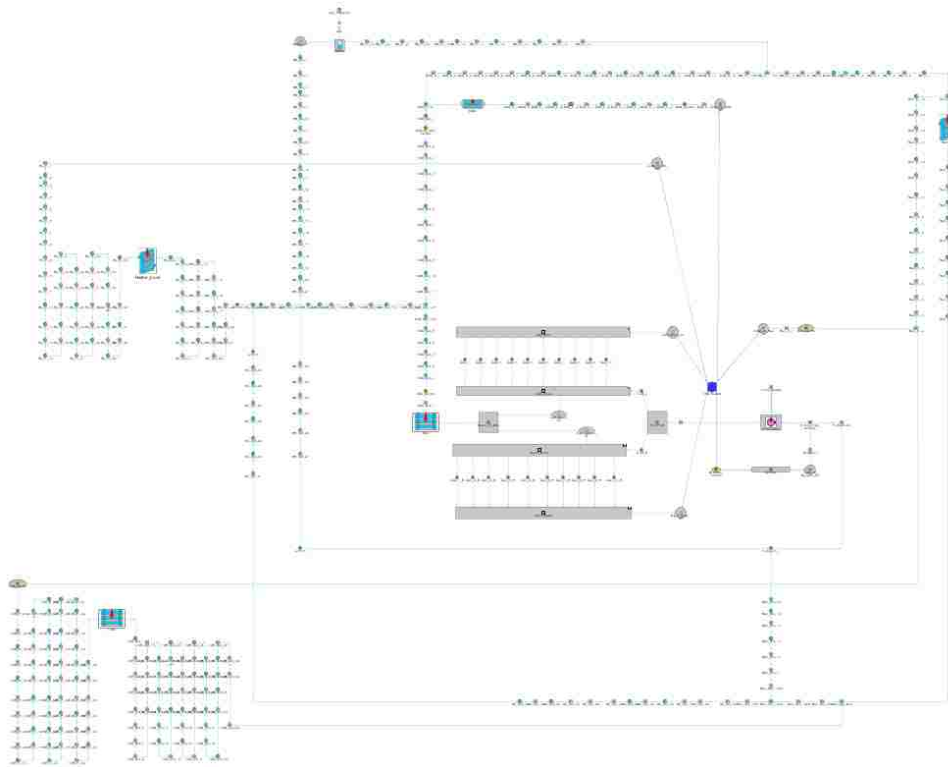

Figure 5. 20 – 1D system level model, with flow component view.

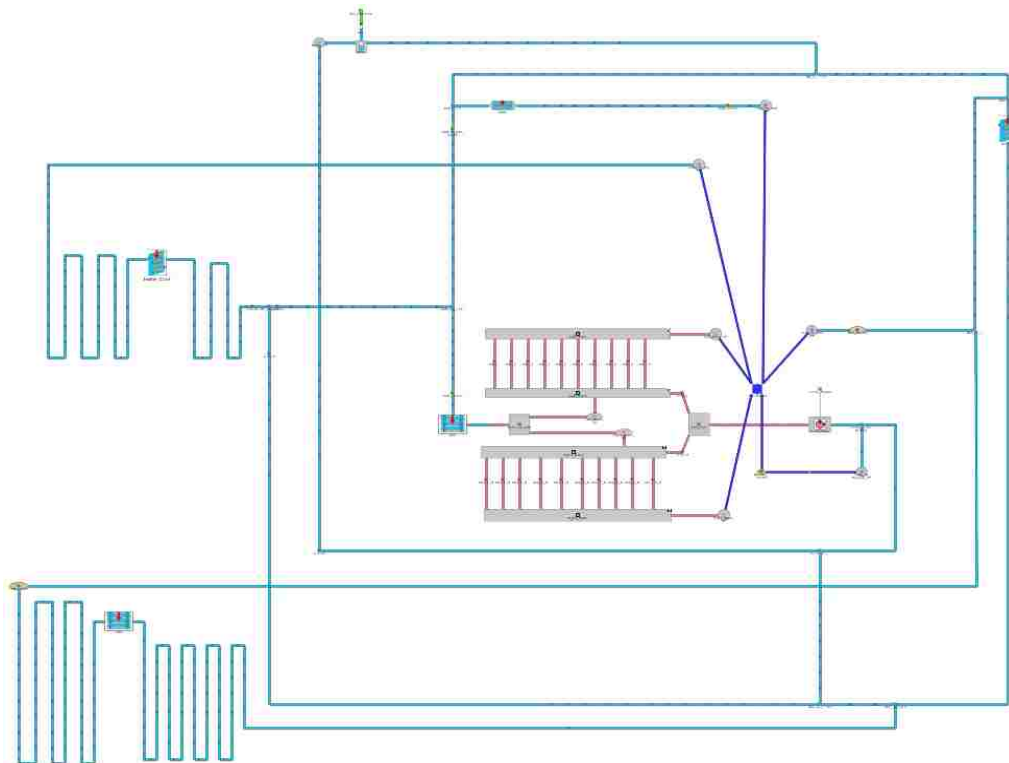

Figure 5. 21 – 1D system level model, with pipe view.

## 5.5 System Model Run Process

The system model was run for two major conditions, open thermostat and closed thermostat. To achieve this, the lift of the thermostat was imposed at 8 mm and 0 mm, respectively. In addition, a wide range of temperature was imposed which matched and/or fell within the range of temperatures at which data was collected on the system level flow bench. To establish the run setup for the system model, the flow control for the solutions for equations (1) -(4) was elected to be implicit as recommend by the software, specifically for cooling systems where wave dynamics are not of interest, the flow is steady, and the simulation involves a single circuit with Mach below 0.3. The implicit solver uses an imposed time step calculation method to solve for the fluid dynamics properties through the simulation, and the time step convergence is checked before advancing to the next time step. The time control was set as continuous with a 10 second maximum. Steady state convergence auto shut-off settings were selected based on flow rate (0.01%) and temperature delta (0.01°C). The pump speed input to the Case setup initialized and controlled the flow of coolant through the coolant loop simulation. For the initial system run, all default settings are kept in the program's implicit run solver and the changes made therefor correlation purposes will be discussed below.

Once a model is run for a given set of conditions, the iterative steps for analyzing the results are as follows:

1. Review flow distribution through each branch and across orifice connections. Check that the summation of flow entering a flow split is equal to the summation of flow exiting a flow split. If any discrepancies occur return to GT-SUITE and update geometry at that location.
2. Review temperature distribution through each set of plumbing lines to ensure uniform and constant temperature distribution (Figure 5.22). If any discrepancies occur, return to GT-SUITE and reset coolant temperature, pipe wall temperature, and any case temperature input.
3. Review pressure output values across pipes, flow splits, and components to ensure a pressure drop, or rise in the case of the pump (Figure 5.23), is occurring. If any discrepancies occur, return to GT-SUITE and update geometry at that location.



## 5.6 System Model Correlation

### 5.6.1 Flow Correlation

For the first simulation, the system was run at ambient temperature to observe whether even flow distribution was achieved through all heat exchanger branches. It was initially observed that uneven flow distribution was occurring through several component branches, meaning too much or too little flow is occurring, and therefore iterative changes were required to correlate the model. When flow components are linked in GT-SUITE, the software imposes an “orifice connection” between the two parts (i.e. pipe to pipe orifice, pipe to component orifice). The orifice connection is where data is retrieved in GT-POST, but also where flow can be controlled by manipulating the “hole diameter” within the orifice connection. This parameter is initially defined by the geometry on either side of it, meaning the diameter of the orifice will match the diameter of the mating component(s) to which it is attached. This orifice connection can also be used to specify a flow restriction by setting the diameter to be smaller than the diameter of the mating components. In particular, orifice alterations were made at the inlet line to the EGRc, heater core and TOH components to adjust and distribute the flow to more accurately represent the flow and pressure drop that was recorded on the flow bench. This is likely due to the pump curves from the supplier only being available at two relatively high temperatures, 85 and 90C. So more flow is leaving the pump than would be in cold cases.

For example, the results from tuning that occurred in the heater core line orifice can be seen in Figure 5.24, where initially the pressure drop was observed to be significantly higher than the flow bench data. Here, the orifice connection was decreased in increments until correlation was achieved within 10%, down from the first iteration of 48% error to 2% error. A further example of orifice tuning, performed on the TOH line, is shown in Figure 5.25. Once adequate and accurate flow was achieved at ambient condition for both the open and closed thermostat setups, and at each component, the overall system 1D model correlation was investigated for the wide range of temperatures and pump speeds to match those at which data was collected on the system flow bench.

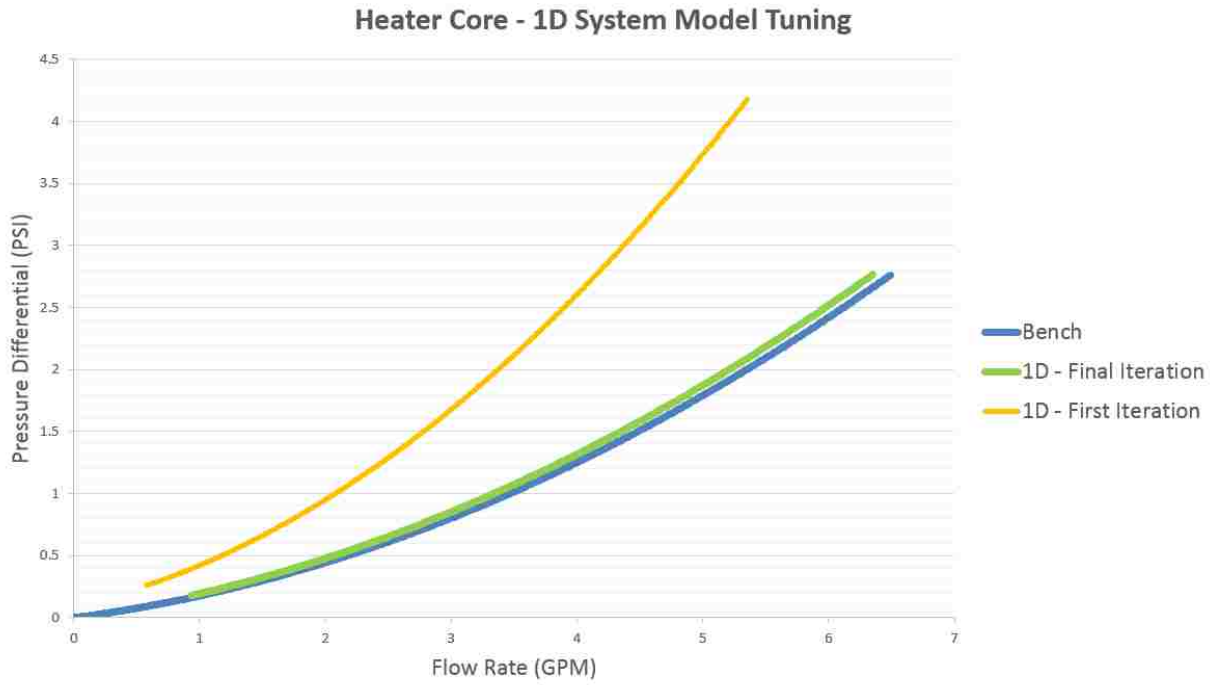

Figure 5. 24 – Heater core correlation within system level model.

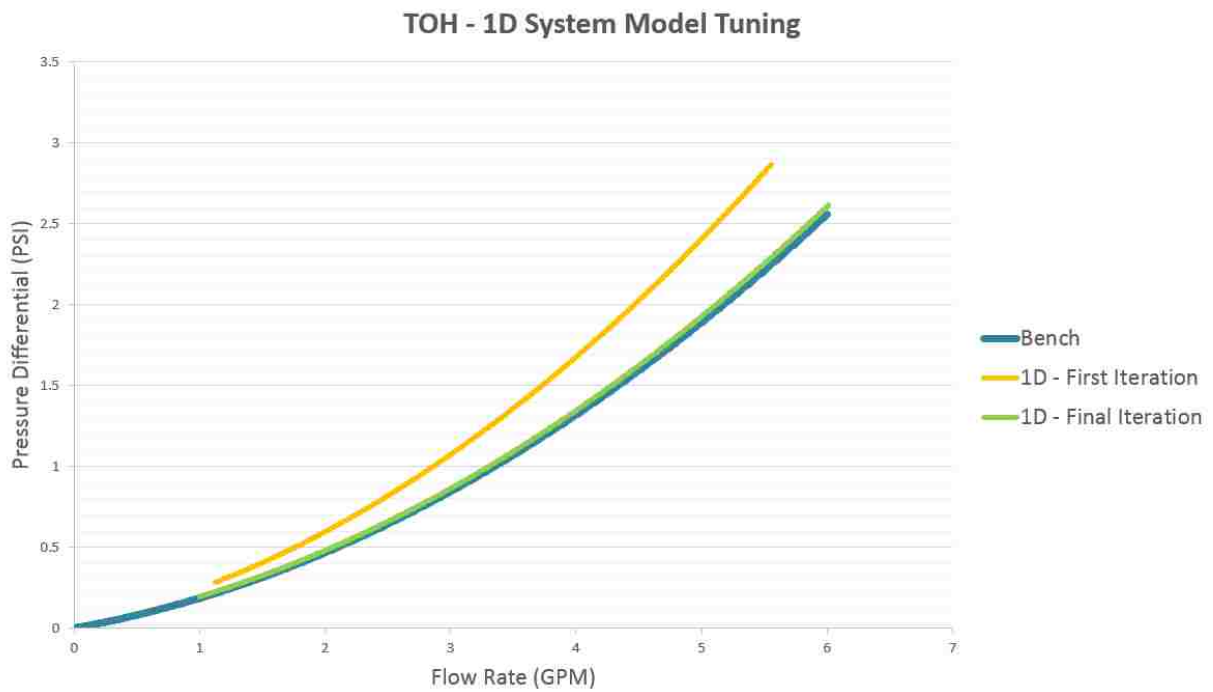

Figure 5. 25 – TOH correlation within system level model.

Figure 5.26 shows the full system pressure drop initial correlation for the 1D model relative to the flow bench results at ambient condition, for both open and closed thermostat position. As discussed in Section 3.4.6, data was collected on the system flow bench for closed thermostat position from -20°C up to 80°C, and for open thermostat position at 20°C and 110°C. Although the thermostat would never be open at ambient coolant temperature in a vehicle, it was helpful to collect the ambient data at both open and closed thermostat conditions to make the overall system correlation, before extending the analysis to higher and lower temperatures.

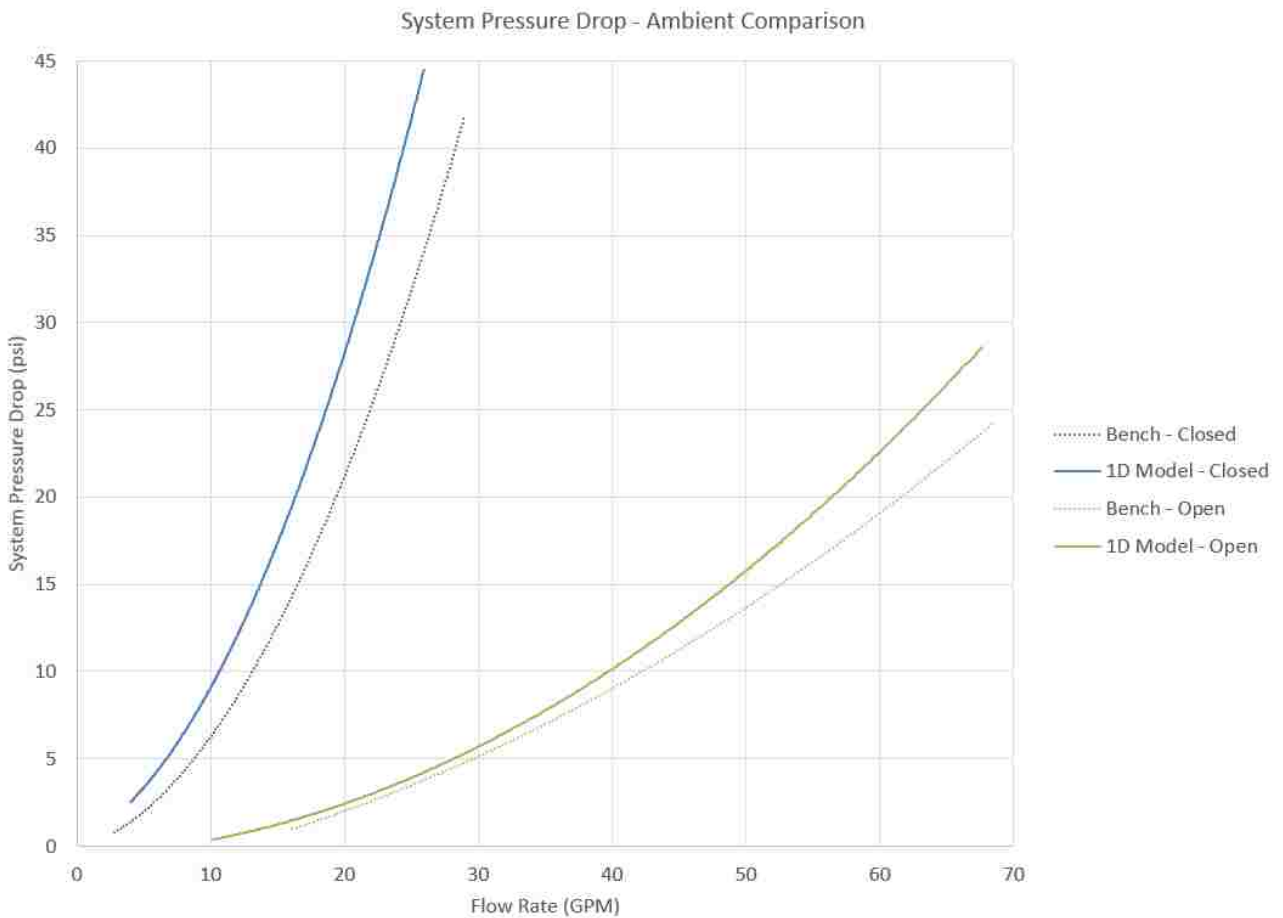

Figure 5. 26 – System pressure drop at ambient condition based on thermostat position.

### 5.6.2 Friction and Pressure Drop Effects

Flow losses through pipes, bends and flow splits due to friction along the walls are calculated in GT-SUITE by using a Fanning friction factor, either as a function of Reynolds number or the wall surface roughness. The roughness is a user defined input, chosen from a library of available surfaces, and the Reynolds number is calculated within the software as a function of pipe geometry. This factor is then used in the momentum equation (Equation 4) during the solving process.

$$\begin{array}{l} \text{Laminar Regime} \\ \text{Friction Factor:} \end{array} \quad C_f = \frac{16}{Re_D} \quad (5)$$

$$\begin{array}{l} \text{Turbulent Regime} \\ \text{Friction Factor:} \end{array} \quad C_f = \frac{0.25}{\left(2 \cdot \log_{10} \left(\frac{1}{2} \frac{D}{\varepsilon}\right) + 1.74\right)^2} \quad (6)$$

where

- $C_f$  Fanning friction factor
- $Re_D$  Reynolds number based on pipe diameter
- $D$  Pipe diameter
- $\varepsilon$  Pipe wall roughness

The surface roughness values used for this project are shown in Table 5.4.

*Table 5. 4 – Roughness from material.*

Material	Wall Roughness (mm)
Smooth Rubber	0.025
Extruded Aluminum	0.003
Steel	0.046

If the default roughness of “0.0” is set, this does not mean that there are no friction losses, but that the surface is modeled as perfectly smooth, like glass. GT-SUITE considers the turbulent regime for coolant flow through pipes and flow splits to be  $Re > 4000$ , and the transition to be  $2000 < Re < 4000$ . Figure 5.27 shows the Reynolds number at three separate locations throughout the system, relative to pump speed over a full engine sweep.

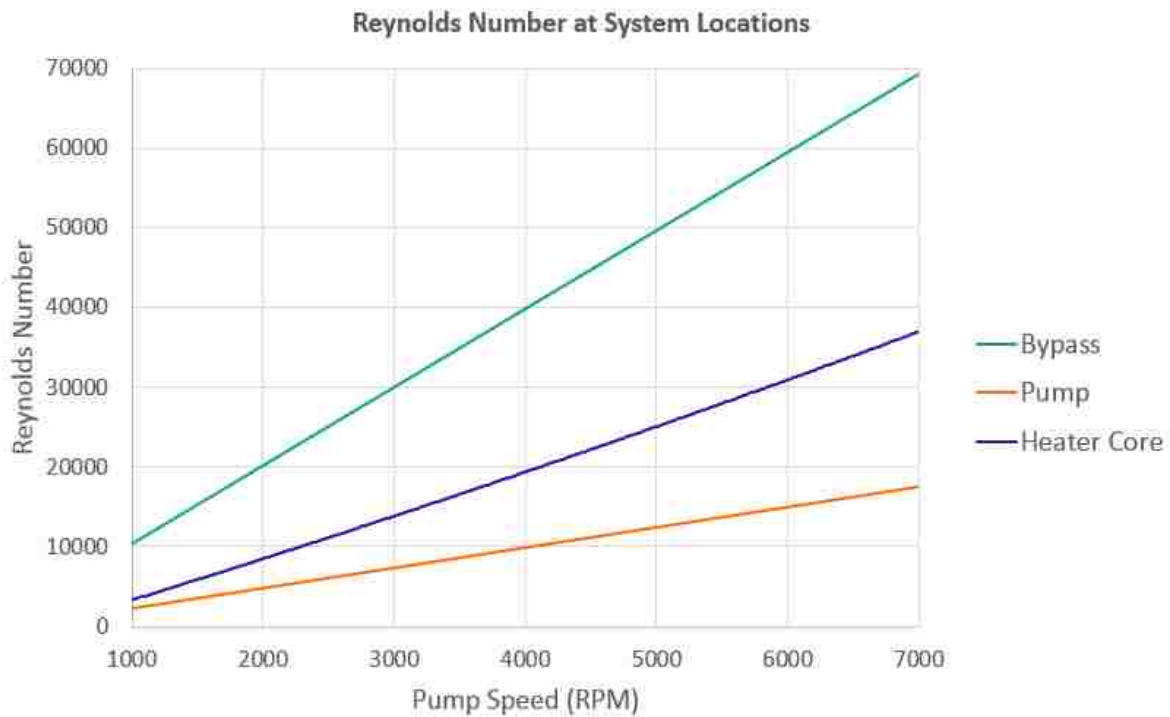

Figure 5. 27 - Reynolds number at locations throughout the engine cooling system.

By this account almost all flow inside the cooling loop can be assumed turbulent for the majority of the operating cycle, and therefore the friction factor which is dependent on surface roughness is almost always being used within the calculation for momentum.



### 5.6.3 Model Over Prediction

Investigating the nature of model over prediction is crucial in achieving better model correlation for flow behaviour at a component and system level. Flow behaviour through each orifice connection, both program defined and user defined, and component roughness factors play a role in the over prediction of pressure drop in the system. Figure 5.28 shows a breakdown of a common set of flow components found throughout the system model, and the orifice connection (OC) that is imposed between each, where the momentum equation is solved.

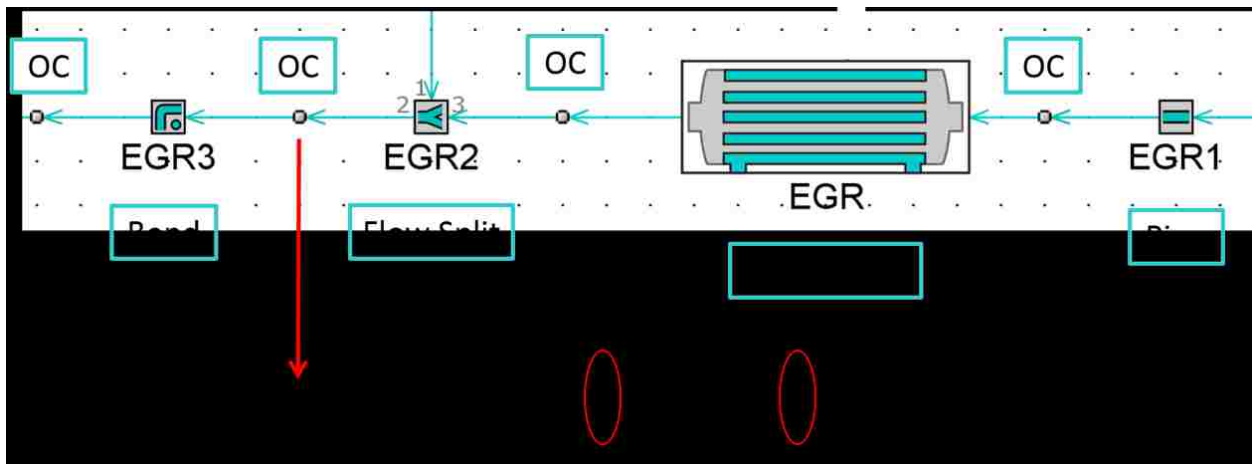

Figure 5. 28 - Pressure drop points in the system model.

Over 300 orifice connections are imposed by the software between components, contributing to the overall pressure drop of the system. As described in the previous sections, it was determined flow distribution through the system required tuning and that orifices can be placed and/or altered in the system to solve this issue. It is up to the user to determine appropriate locations. Due to the implementation of these additional orifices, pressure drop over the entire system increases again. When comparing the relationships in Figure 5.26, the average difference in pressure drop in the closed system is higher than that in the open system, which shows that the addition of user defined orifices is attributing to the over prediction of the pressure drop.

Although there is no change in the actual geometry of the pipe network, GT-SUITE implements a Forward/Reverse End Correction at each orifice. This correction comes in the form of the addition of “virtual mass” equal to 0.35 times the diameter of the orifice and is required in order to solve the momentum equation. Due to this addition of “virtual mass” there will also be an addition of

friction forces in the system. This contributes to a higher pressure drop in the system model when compared to the experimental bench data.

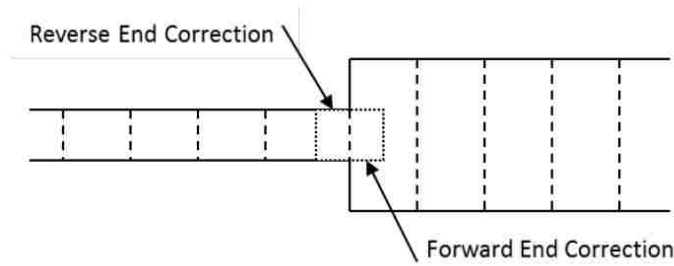

Figure 5. 29 - Virtual mass correction for pressure drop calculation.

To help mitigate the over prediction, the use of a global friction multiplier (GFM) and a pressure drop multiplier (PDM) can be introduced. The GFM is imposed on all pipes, bends, flow splits and components in the system. The PDM is imposed on an individual component, and applies to the pressure drop being calculated across that one component. Correlation for pressure drop vs. flow rate is established first at each component within the system, then the system performance can be correlated. By starting at a global friction multiplier of 1.0 (default) and dropping 50% each iteration it was determined that a GFM of 0.25 was best suited for achieving correlation across all components at a full range of temperatures.

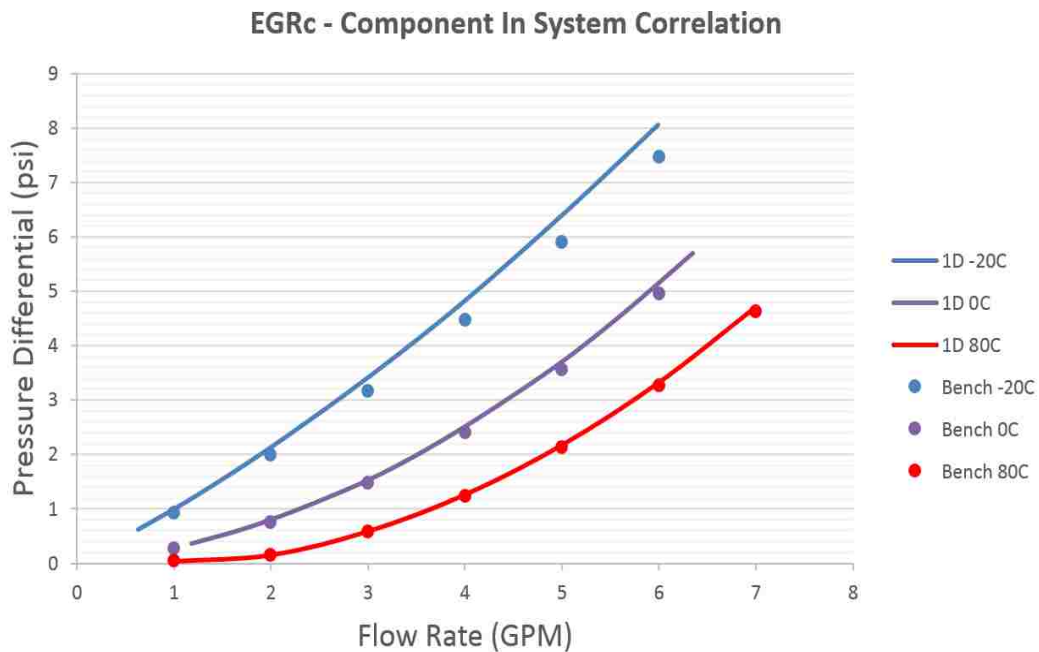

Figure 5. 30 – Extreme cold component model correlation.

Figure 5.30 shows the model correlation that was achieved at the EGRc in the system model by imposing a GFM of 0.25, at extreme cold and hot conditions versus the experimental bench data. Once each component model within the system is confirmed to correlate, the overall system pressure drop can be tuned by imposing a PDM. Figure 5.31 shows the 1D software over predicting the system pressure drop at extreme cold through ambient temperatures, after the implementation of a GFM.

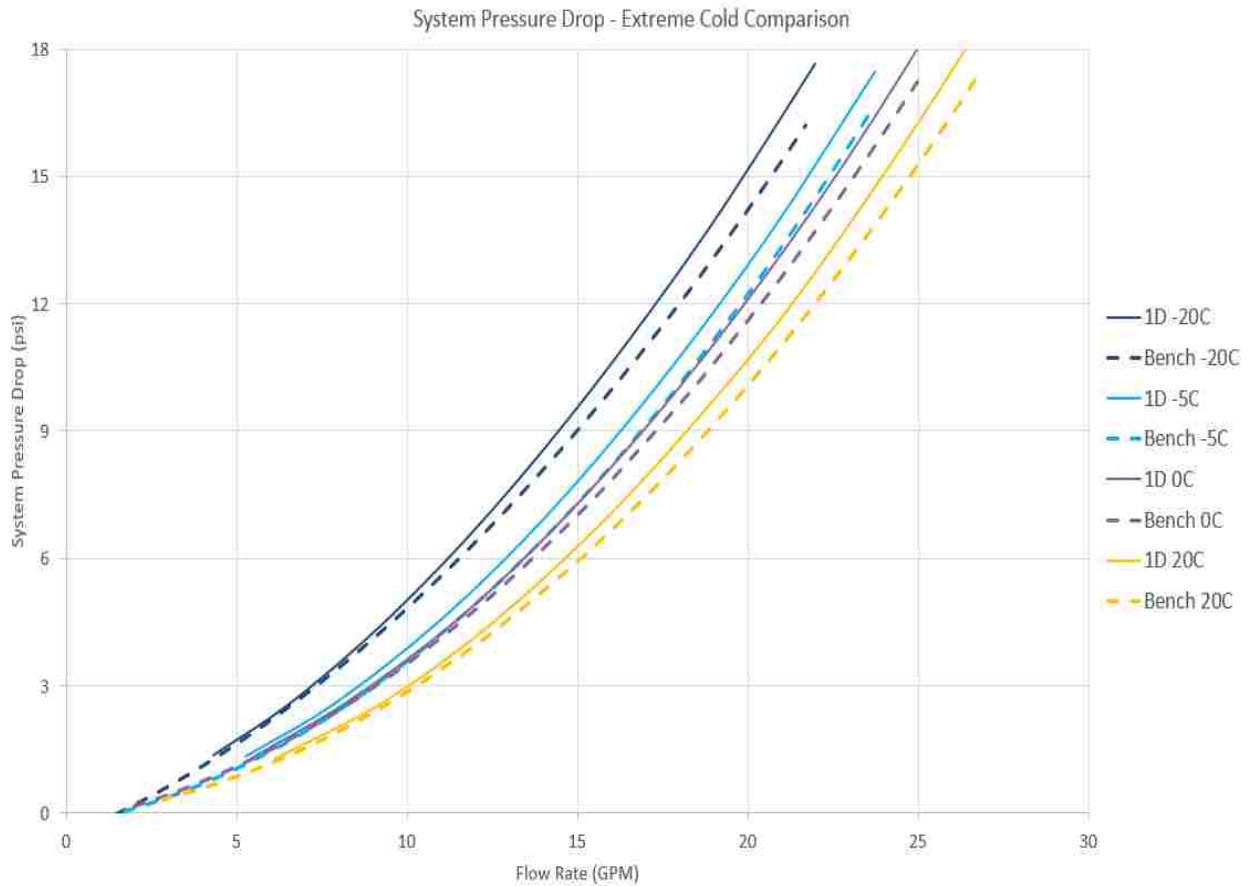

Figure 5. 31 – Extreme cold system model overprediction.

As mentioned before, the available pump curves were limited to two relatively high temperatures, and this is likely contributing to the lack of correlation at a system level for lower temperatures. Therefore, a PDM is introduced across the pump using a similar approach as with the GFM, to bring down the overall system pressure drop. The best fit system PDM was determined to be ranging from 0.92 to 0.98, depending on the temperature of the system. Figure

5.32 shows the correlation approach taken at extreme cold, bringing the correlation within 10% through the use of GFM, and achieving correlation within 3% by finally implementing a PDM.

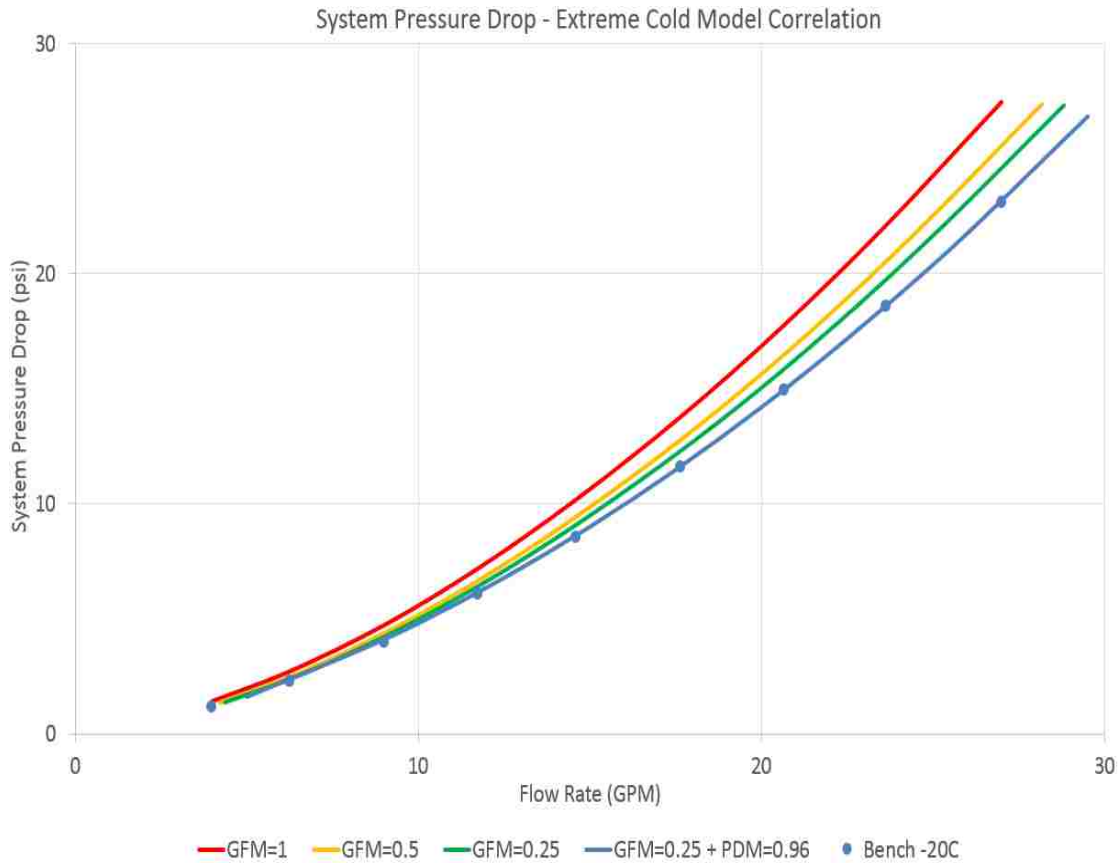

Figure 5. 32 – Extreme cold system model correlation.

The range of temperatures at which both system and component data was collected proved useful for predicting coolant performance at a range of temperatures with confidence. Without having collected this data, the simulations could have been run at extreme conditions, but with no data to correlate with for confirmation on the validity of the modelling results.

## 5.7 Limitations of System Simulation

System simulation is a useful tool for solving fluid dynamics problems for preliminary verification of performance, size and function of various components in a system and for the system as a whole. However, all numerical modelling requires approximations to be made to solve the principles of fluid flows, and consequently limitations exist. System simulation solves ordinary differential equations as a function of time, in one dimension, and therefore properties are averaged over the two remaining dimensions. This means that the software lacks the ability to capture complex flow phenomena, such as flow separation and local flow velocities. Therefore, the use of global friction multipliers and pressure drop multipliers are introduced to better correlate the model to physical results.

It is likely that the tuning required in the 1D modelling process is due to the software's lack of ability to model turbulence, and therefore adjustments in geometry inputs and tuning factors are required to account for viscous effects. The higher Reynolds numbers are contributing to the greater divergence in model correlation, particularly at the higher coolant flow rates. At these turbulent conditions, eddies and vortices are occurring at several locations throughout the system, however the software only provides results for flow and pressure quantities on either side of a flow component. No 3D irregularities are being captured inside each component, because in its essence, 1D simulation is a simplification that models the interaction between many components that make up a complex system. To model the 3D CFD of this engine cooling system would take copious amount of time and is beyond the scope of this project. However, by including the detailed dissections of the plumbing and water jacket in the modelling process, the flow and pressure results available at each orifice connection are more refined and detailed than if the system were to be over-simplified using a one-inlet/one-outlet black box approach.

It is unlikely that an engine water pump would operate at the high end of the RPM spectrum used throughout this project for any significant length of time, and therefore the accuracy of the correlation within the mid-range of the operating range is satisfactory. Incorporation of more detailed data, particularly with respect to the heat transfer side of engine cooling, would likely help to mitigate inconsistencies related to turbulence at high flow rates and viscosity at extreme cold conditions.

## 6. Conclusions

In this thesis, a robust 1D system simulation model was developed and validated for an engine cooling system. A summary of the work and key findings are given in this chapter, and recommendations for future work are presented.

### 6.1 Summary

In the past, research has been conducted on the development of engine cooling systems in a variety of capacities. Some incorporated bench testing of peripheral cooling components, some involved flow modelling of individual components or a limited combination of components, and some incorporated simplified 1D models of a full engine cooling system. However, none of these research efforts incorporated all of these ideas together in a detailed capacity, with a specific focus on the coolant side fluid dynamics, at a comprehensive range of temperatures and with insight into the water jacket.

The experimental part of the project reported in this thesis involved the development of two flow benches which utilized similar instrumentation approaches. The single component bench was used to test individual heat exchangers one at a time, collecting pressure and flow rate data at ambient and operating temperatures. This bench and the data it produced was critical to validating and filling any voids in supplier provided data. In addition, the single component bench data was critical to validating single component 1D models. The system level bench was used to test the complete engine cooling system, collecting pressure and flow data across all heat exchangers, the thermostat, pump and water jacket, at a range of pump speeds from 1000 RPM to 7000 RPM, and temperatures from -20°C to 110°C. This bench and the data it produced further validated the single component bench data, provided previously unavailable information on the coolant flow behaviour inside the engine water jacket, and was critical to validating the system level 1D model.

The numerical part of this project involved the development of 1D system simulation models at a component level, and ultimately the compilation of these into a complete and reliable engine cooling system model using GT-SUITE software. In order to diligently build 1D models of each heat exchanger, a meticulous dissection was performed on each physical part to gain a better

understanding of the internal geometry and flow passages. GEM3D, a GT-SUITE compatible tool, was used to carefully discretize the 3D plumbing line geometry into individual pipes and flow splits, and ultimately 1D model files. Modelling the complex water jacket posed significant challenges; first, discretizing the 3D geometry into a number of suitable 1D flow splits, and second, manipulating the 1D model to accurately and efficiently capture coolant flow behaviour through the flow splits of the block and head subassemblies, and through critical gasket hole connections. The review and breakdown of existing 3D CFD results at key locations, particularly on either side of the thermostat and water jacket, further supported the modelling of these critical components which do not have supplier data, and were instrumented exclusively on the system level flow bench. Once individual models were correlated with the appropriate data, everything was combined into a complete engine cooling system model and validated for a range of conditions corresponding to the system flow bench.

## 6.2 Conclusions

The flow benches developed for this project provided essential data for each stage of modelling the cooling system. In particular, the detailed instrumentation of the engine block was fundamental to validating the water jacket model. Developing a complete and operational water jacket model was a key achievement, not only for validating the pressure drop data across inlet and outlet of the block and head, but also for gaining the ability to observe the flow and pressure behaviour across gasket holes and internal flow splits. In addition, the extension of bench testing capabilities to include extreme cold and hot operating temperatures provided the ability to model the viscous effects of coolant under a wide range of conditions with relative certainty. Furthermore, the physical dissection of parts proved to be crucial in the heat exchanger modelling stage, for determining the geometry inputs which have the most influence on component model accuracy. Tuning factors were determined to be necessary within plumbing branches that supply heat exchangers, for closed versus open thermostat conditions of the system level model as a means for controlling flow, along with imposing thermostat lift. The 3D CFD results available for this engine correlated well with the bench data, and subsequently the bench data correlated well with the 1D model results.

The confidence interval for each type of 1D model developed for this project, relative to the bench data, was within the following percentages:

- 3% for heat exchanger models
- 5% for water jacket, thermostat and pump models
- 10% for system level model

Whether a vehicle is starting in subzero temperatures, idling at a stop light, driving up hill or towing a trailer, the engine cooling system needs to perform adequately. An accurate flow model for the cooling loop is the first step towards develop a robust transient thermal model, and optimizing the effectiveness of the engine cooling loop is critical to safe and efficient operation of the vehicle. In conclusion, the goal of this thesis to accurately capture and characterize the flow behaviour of engine coolant in a vehicle engine cooling system, using a 1D system level model, was achieved. It can be concluded that 1D system simulation is a viable option for fast, adaptable numerical modelling in early vehicle development.

### 6.3 Future Recommendations

In order to further validate the methods developed for this project, it is recommended to extend this approach to additional engines and engine cooling system configurations. In addition, the incorporation of 3D modelling results, particularly the cross-sections of plumbing and water jacket contours for flow rate and pressure, would provide further validation for locations where experimental data was deficient. Furthermore, making use of the procedures described in this thesis for detailed geometry investigation and incorporating the alternate loop of each heat exchanger (i.e. air flow side for radiator, oil circuit for the TOH, etc.) is recommended as the next stage in the process of engine development, by modelling the exchange of heat between the fluids on either side. Finally, although cumbersome and time consuming, the integration of vehicle level test data (once available) would be advantageous for supplementary validation.



## References

1. Crolla, D.A., ed., "Automotive Engineering: Powertrain, Chassis System and Vehicle Body," 1. ed, Elsevier, Butterworth-Heinemann, Amsterdam, ISBN 978-1-85617-577-7, 2009.
2. GT-Suite Flow Theory Manual, Gamma Technologies, 2014.
3. Stratton, D.G., Stringer, R.E., and Taylor, S.R.G., "Engine Cooling System Design and Development," Proceedings of the Institution of Mechanical Engineers: Automobile Division 180(1):221–235, 1965, doi:10.1243/PIME\_AUTO\_1965\_180\_023\_02.
4. Kanefsky, P., Nelson, V.A., and Ranger, M., "A Systems Engineering Approach to Engine Cooling Design," 1999, doi:10.4271/1999-01-3780.
5. Ethylene Glycol Heat-Transfer Fluid, [https://www.engineeringtoolbox.com/ethylene-glycol-d\\_146.html](https://www.engineeringtoolbox.com/ethylene-glycol-d_146.html), Jul. 2019.
6. Solomon, S., "Prediction of Thermal Performance of Radiator Using 1-D Method," 2013, doi:10.4271/2013-01-2810.
7. Liang, L., Ge, H., Ge, H., and Zhao, P., "A 1-D Platform to Simulate the Effects of Dedicated EGR on SI Engine Combustion," 2017, doi:10.4271/2017-01-0524.
8. Shabgard, H., Kheradmand, S., Farzaneh, H., and Bae, C., "Numerical Simulation of Cooling Performance of an Exhaust Gas Recirculation (EGR) Cooler Using Nano-Fluids," Applied Thermal Engineering 110:244–252, 2017, doi:10.1016/j.applthermaleng.2016.08.139.
9. Hjälms Wallborg, M. and Palmgren, J., "Improving Engine Oil Cooler Performance: For Future Vehicle Applications," 2015.
10. Mehravaran, M. and Zhang, Y., "Optimizing the Geometry of Degas Bottle Using CAE/CFD," 2017, doi:10.4271/2017-01-1321.
11. Water Pumps in Automotive Engine Coolant Systems, ASE Certification Training HQ, 2015.
12. Cehreli, Z.N., "Cooling System Optimization on a 5-Cylinder Engine," 2007, doi:10.4271/2007-01-2600.
13. GmbH, R.B., "Automotive Handbook," 9th Edition, Wiley, Chichester, ISBN 978-1-119-03294-6, 2015.
14. Vdovin, A., "Cooling Performance Simulations in GT-SUITE," 2010. Chalmers University of Technology.
15. Mulemane, A. and Soman, R., "CFD Based Complete Engine Cooling Jacket Development and Analysis," 2007, doi:10.4271/2007-01-4129.
16. Krakowski, R., "Internal Combustion Engine Cooling System with Elevated Coolant Temperature Research on the Model test Stand," Journal of KONES. Powertrain and Transport 20:177–183, 2015, doi:10.5604/12314005.1137614.

17. Chastain, J., Wagner, J., and Eberth, J., "Advanced Engine Cooling – Components, Testing and Observations," IFAC Proceedings Volumes 43(7):294–299, 2010, doi:10.3182/20100712-3-DE-2013.00007.
18. Saidi, M., A. Mozafari, A., R. Esmaili Sany, A., and Neyestani, J., "Experimental Study of Thermal Performance and Pressure Drop in Compact Heat Exchanger Installed in Automotive," 2006, doi:10.1115/ICES2006-1333.
19. Kneba, Z. and Smieja, M., "The Use of CAN in Automation Test Bench to Test the Engine Cooling System," 2010.
20. Gu, N. and Ni, J., "Simulation of Engine Cooling System Based on AMESim," Second International Conference on Information and Computing Science, 117–120, 2009, doi:10.1109/ICIC.2009.339.
21. Mahmoud, K.G., Loibner, E., and Krammer, J., "Integrated 1-D Tools for Modeling Vehicle Thermal Management System," 2004, doi:10.4271/2004-01-3406.
22. Michelotti, A.C. and Silva, J.C. da, "1-D Dynamic Modeling and Sensitivity Analysis in Product Design," SAE Technical Paper 2008-36–0134, SAE International, Warrendale, PA, 2008, doi:10.4271/2008-36-0134.
23. Watanabe, N., Kubo, M., and Yomoda, N., "An 1D-3D Integrating Numerical Simulation for Engine Cooling Problem," 2006, doi:10.4271/2006-01-1603.
24. De Risi, A., Zecca, R., and Laforgia, D., "Optimization of a Four Stroke Engine by Means of Experimental and 1-D Numerical Analysis," 2000, doi:10.4271/2000-01-0566.
25. Pathuri, R.B. and Nagarhalli, P., "Deployment of 1D Simulation for Engine Cooling Performance and its Correlations with Vehicle Level Testing," 2015-26–0216, SAE International, Warrendale, PA, 2015, doi:10.4271/2015-26-0216.
26. Bolehovský, O. and Novotný, J., "Influence of Underhood Flow on Engine Cooling Using 1-D and 3-D Approach," Journal of Middle European Construction and Design of Cars 13(3):24–32, 2015, doi:10.1515/mecdc-2015-0012.

## Appendix A: Uncertainty Analysis

In order to investigate the uncertainty of the instrumentation used in the experimental portion of this research, analysis was done across a heat exchanger to represent key data that was used to correlate all 1D models. For the below calculations, the heater core single component data was used, at ambient temperature, and averaged for both pressure differential and flow rate from the full sweep of pump RPM outputs, assuming n=100 engine cycles.

Table A. 1 – Uncertainty analysis calculations.

Flow Meter	Pressure Transducer
Manufacturers uncertainty → ±0.05% Non-linearity → 0.27% Hysteresis → 0.05% Average flow rate → 7.83GPM	Manufacturers uncertainty → ±0.05% Non-linearity → 0.2% Hysteresis → 0.2% Average pressure differential → 5.98 PSI
$u_{non-lin} = 7.83(0.0027) = 0.021 \text{ GPM}$ $u_{hyst} = 7.83(0.0005) = 0.004 \text{ GPM}$ $\delta_z = \sqrt{(u_{non-lin})^2 + (u_{hyst})^2}$ $\delta_z = \sqrt{(0.021)^2 + (0.004)^2}$ $\delta_z = 0.0213 \text{ GPM}$ $\delta_{z \text{ avg}} = \frac{\delta_z}{\sqrt{n-1}}$ $\delta_{z \text{ avg}} = \frac{0.0213}{\sqrt{100-1}}$ $\delta_{z \text{ avg}} = 0.002 \text{ GPM}$	$u_{non-lin} = u_{hyst} = 5.98(0.002) = 0.095 \text{ PSI}$ $\delta_z = \sqrt{(u_{non-lin})^2 + (u_{hyst})^2}$ $\delta_z = \sqrt{(0.095)^2 + (0.095)^2}$ $\delta_z = 0.134 \text{ PSI}$ $\delta_{z \text{ avg}} = \frac{\delta_z}{\sqrt{n-1}}$ $\delta_{z \text{ avg}} = \frac{0.134}{\sqrt{100-1}}$ $\delta_{z \text{ avg}} = 0.001 \text{ PSI}$

Therefore, the uncertainty in flow meter measurement is ± 0.002 GPM, and the uncertainty in pressure differential measurement is ± 0.001 PSI.

## Appendix B: DOE Study

Within GT-SUITE there exists the capability to define a Design of Experiments (DOE) and post-process the results it produces. The DOE parameter chosen can be any model input which is defined in the Case Setup, and for the purpose of this thesis the coolant temperature was a key parameter being defined. To begin a DOE study, the range at which the temperature was being investigated was defined, as well as the number of experiments to perform within this temperature range (Figure A1). For example, if there are 5 cases being run in the model, and 5 DOE experiments chosen, then 25 total experiments will be run.

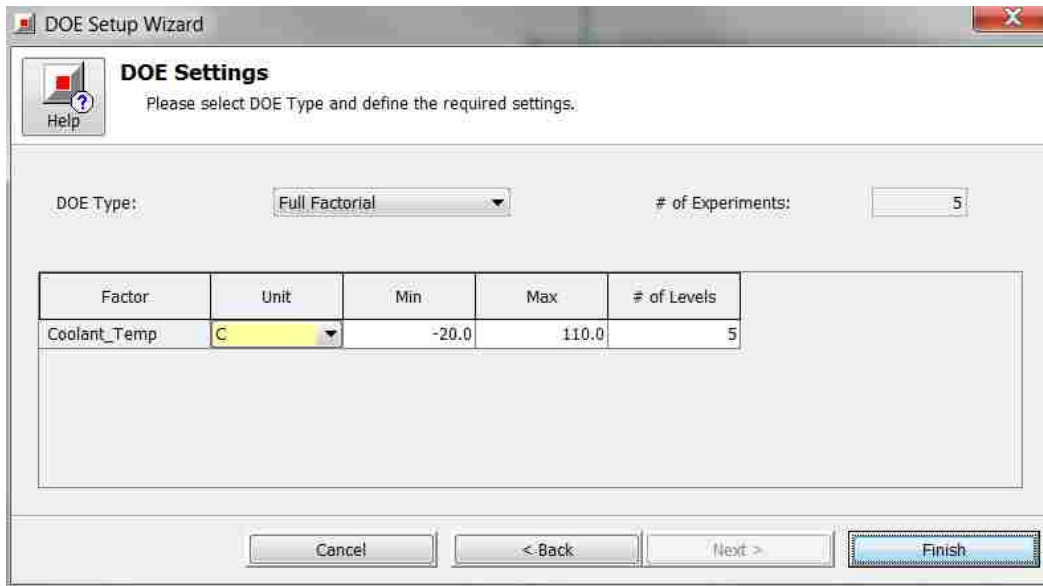

Figure A. 1 – DOE parameter set-up and experiment number definition.

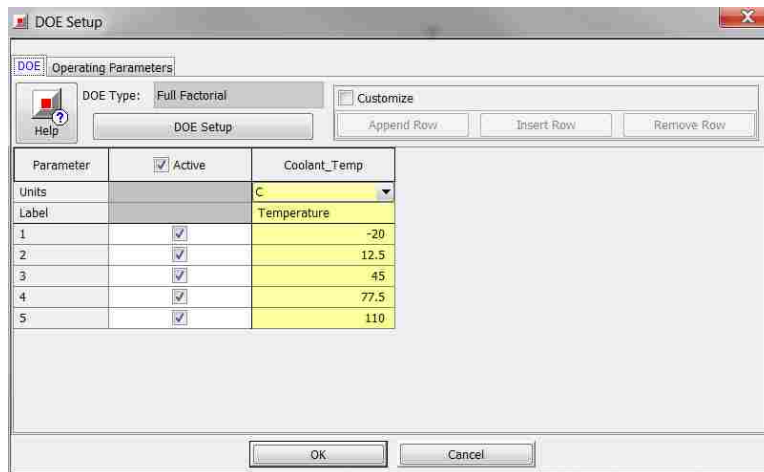

Figure A. 2 – Temperature parameter range.

Figure A2 shows the exact temperature values at which each experiment will be evaluated. Each case corresponds to a specific pump RPM, and once the model is run the results of interest are

chosen to be displayed at each case. Figure A3 shows the pressure drop has been chosen for each heat exchanger. Figures A4 & A5 show the full results from the DOE study at 1000RPM and 2000RPM respectively. This type of study is extremely useful and convenient for investigating a wide range of results within one simulation run.

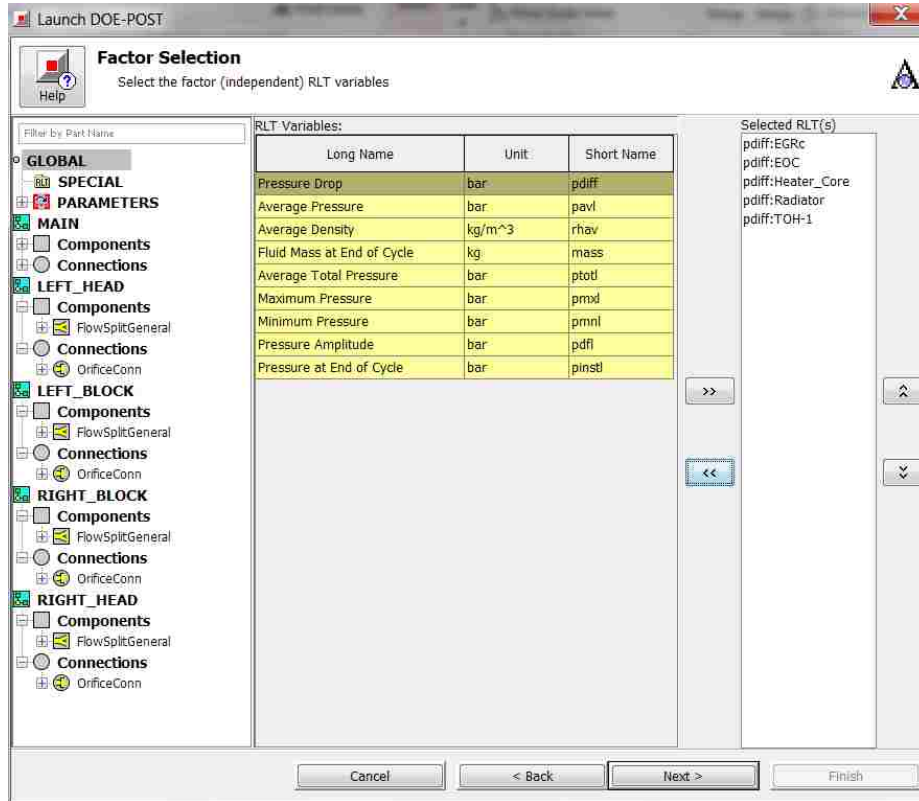

Figure A. 3 – Result display selection for pressure drop across each heat exchanger.

Worksheet Matrix

Case : Pump\_Speed(1000) Select Experiments

Expt. No.	In/Out	coolant_temp	pdiff_EGRc	pdiff_EOC	pdiff_Heater_Core	pdiff_Radiator	pdiff_TOH_1
1	✓	-20.0	0.261754	0.115976	0.481431	0.834709	0.366824
2	✓	12.5	0.180167	0.115284	0.379739	0.633498	0.348789
3	✓	45.0	0.0976067	0.112438	0.304099	0.502343	0.294364
4	✓	77.5	0.0578898	0.107628	0.246982	0.389546	0.237444
5	✓	110.0	0.0174091	0.105856	0.205629	0.303656	0.191247

Figure A. 4 – DOE study results for pressure drop across heat exchangers, at 1000 RPM pump speed.

Worksheet Matrix

Case : Pump\_Speed(2000) Select Experiments

Expt. No.	In/Out	coolant_temp	pdiff_EGRc	pdiff_EOC	pdiff_Heater_Core	pdiff_Radiator	pdiff_TOH_1
1	✓	-20.0	0.593373	0.295981	0.87118	2.02636	0.803567
2	✓	12.5	0.452171	0.288172	0.826345	1.64474	0.805977
3	✓	45.0	0.328404	0.271888	0.728527	1.34887	0.693442
4	✓	77.5	0.202538	0.250823	0.599834	1.09529	0.588838
5	✓	110.0	0.108988	0.231392	0.45398	0.879011	0.47421

Figure A. 5 – DOE study results for pressure drop across heat exchangers, at 2000 RPM pump speed.

## Vita Auctoris

NAME: Elle Mistruzzi

PLACE OF BIRTH: Windsor, ON, Canada

YEAR OF BIRTH: 1990

EDUCATION: University of Windsor, Master of Applied Science  
Mechanical Engineering  
Windsor, ON, Canada, 2019

University of Windsor, Bachelor of Applied Science  
Mechanical Engineering with Aerospace Option  
Windsor, ON, Canada, 2017

St. Leonard's College  
International Baccalaureate Diploma  
Melbourne, VIC, Australia, 2008