

8-1-2012

Impact of Secondary Treatment Types and Sludge Handling Processes on Estrogen Concentration in Wastewater Sludge

Erica J. Marti

University of Nevada, Las Vegas, martie2@unlv.nevada.edu

Follow this and additional works at: <https://digitalscholarship.unlv.edu/thesesdissertations>



Part of the [Environmental Engineering Commons](#), and the [Environmental Health and Protection Commons](#)

Repository Citation

Marti, Erica J., "Impact of Secondary Treatment Types and Sludge Handling Processes on Estrogen Concentration in Wastewater Sludge" (2012). *UNLV Theses, Dissertations, Professional Papers, and Capstones*. 1684.

<https://digitalscholarship.unlv.edu/thesesdissertations/1684>

This Thesis is protected by copyright and/or related rights. It has been brought to you by Digital Scholarship@UNLV with permission from the rights-holder(s). You are free to use this Thesis in any way that is permitted by the copyright and related rights legislation that applies to your use. For other uses you need to obtain permission from the rights-holder(s) directly, unless additional rights are indicated by a Creative Commons license in the record and/or on the work itself.

This Thesis has been accepted for inclusion in UNLV Theses, Dissertations, Professional Papers, and Capstones by an authorized administrator of Digital Scholarship@UNLV. For more information, please contact digitalscholarship@unlv.edu.

IMPACT OF SECONDARY TREATMENT TYPES AND SLUDGE HANDLING
PROCESSES ON ESTROGEN CONCENTRATION
IN WASTEWATER SLUDGE

by

Erica Marti

Bachelor of Science
University of Illinois at Urbana-Champaign
2004

Master of Education
University of Nevada, Las Vegas
2007

A thesis submitted in partial fulfillment
of the requirements for the

Master of Science in Engineering

**Department of Civil and Environmental Engineering
Howard R. Hughes College of Engineering
The Graduate College**

**University of Nevada, Las Vegas
August 2012**



THE GRADUATE COLLEGE

We recommend the thesis prepared under our supervision by

Erica Marti

entitled

**Impact of Secondary Treatment Types and Sludge Handling Processes
on Estrogen Concentration in Wastewater Sludge**

be accepted in partial fulfillment of the requirements for the degree of

Master of Science in Engineering

Department of Civil and Environmental Engineering

Jacimaria Batista, Committee Chair

Sajjad Ahmad, Committee Member

David James, Committee Member

Spencer Steinberg, Graduate College Representative

Thomas Piechota, Ph. D., Interim Vice President for Research and Graduate Studies
and Dean of the Graduate College

August 2012

ABSTRACT

Impact of Secondary Treatment Types and Sludge Handling Processes on Estrogen Concentration in Wastewater Sludge

by

Erica Marti

Dr. Jacimaria Batista, Examination Committee Chair
Professor, Civil and Environmental Engineering
University of Nevada, Las Vegas

Endocrine-disrupting compounds (EDCs), such as estrogen, are known to be present in the aquatic environment at concentrations that negatively affect fish and other wildlife. Wastewater treatment plants (WWTPs) are major contributors of EDCs into the environment. EDCs are released via effluent discharge and land application of biosolids. Estrogen removal in WWTPs has been studied in the aqueous phase; however, few researchers have determined estrogen concentration in sludge. This study focuses on estrogen concentration in wastewater sludge as a result of secondary treatment types and sludge handling processes. Grab samples were collected before and after multiple treatment steps at two WWTPs receiving wastewater from the same city. The samples were centrifuged into aqueous and solid phases and then processed using solid phase extraction. Combined natural estrogens (estrone, estradiol and estriol) were measured using an enzyme-linked immunosorbent assay (ELISA) purchased from a manufacturer. Results confirmed that activated sludge treatments demonstrate greater estrogen removal compared to trickling filters and estrogen load (mass estrogen per mass solid) was

measured for the first time on trickling filter solids. Physical and mechanical sludge treatment processes, such as gravity thickeners and centrifuges, did not significantly affect estrogen removal based on mass balance calculations. Dissolved air flotation demonstrated a slight decrease in estrogen concentration, while anaerobic digestion resulted in increased estrogen load on the sludge and a high estrogen concentration in the supernatant. Although there are no state or federally mandated discharge effluent standards or sludge application standards for estrogen, implications from this study are that trickling filters would need to be exchanged for activated sludge treatment or followed by an aeration basin in order to improve estrogen removal. Also, anaerobic digestion may need to be replaced with aerobic digestion for sludge that is intended for land application.

ACKNOWLEDGEMENTS

I would like to thank my advisor, Dr. Jacimaria Batista, for all of her help and guidance during my thesis research and writing. Her advice is invaluable and her dedication to her students is admirable.

I would like to thank several organizations and individuals for their support as I conducted my research: the Clark County Water Reclamation District and the City of Las Vegas Water Pollution Facility for their assistance in obtaining samples and operational information for the treatment plants; Tammy Jones-Lepp and Tom Moy at the United States Environmental Protection Agency for help completing the sludge extractions; Amber Howerton for instructing me on microplate analysis with ELISA; Guadalupe (Gutierrez) Bailey and Leah Irons for their laboratory assistance with sample preparation, and finally the Graduate Student Professional Association for financial support.

TABLE OF CONTENTS

ABSTRACT	iii
ACKNOWLEDGEMENTS	v
LIST OF FIGURES	ix
LIST OF TABLES	x
CHAPTER 1 INTRODUCTION	1
1.1 Research Problem.....	1
1.2 Issue One: Impact of Secondary Treatment Type on Estrogen Concentration for Wastewater Sludge	2
1.3 Issue Two: Impact of Sludge Handling Processes on Estrogen Concentration for Wastewater Sludge	3
1.4 Research Objectives and Hypotheses.....	4
CHAPTER 2 STATE OF THE KNOWLEDGE	6
2.1 Natural, Synthetic and Metabolite Forms of Estrogen	6
2.2 Effect of Estrogen as an Endocrine Disrupting Compound	9
2.3 Presence of Estrogen in Wastewater Treatment.....	11
2.4 Removal Mechanisms for Estrogen in Wastewater Treatment.....	13
2.5 Analytical Methods for Determining Estrogen Potency	16
2.6 Analytical Methods for Determining Estrogen Concentration	17
2.7 Quality Assurance and Quality Control Considerations	19
2.8 Secondary Wastewater Treatment Processes	20
2.8.1 Activated Sludge.....	20
2.8.2 Biological Nutrient Removal.....	21

2.8.3 Tricking Filters	22
2.9 Sludge Handling Processes	23
2.9.1 Sludge Thickening.....	23
2.9.2 Mechanical Dewatering.....	24
2.9.3 Sludge Digestion.....	25
2.10 Return Streams	26
CHAPTER 3 METHODOLOGY	28
3.1 Wastewater Treatment Facility Overview.....	28
3.2 Collection and Preparation of Samples	31
3.3 Sample Extraction	31
3.3.1 Solid Phase Extraction for Dried Sludge Samples	32
3.3.2 Solid Phase Extraction for Aqueous Samples	34
3.4 Enzyme-linked Immunosorbent Assay (ELISA) Analysis	35
3.5 Interpolation of Absorbance Data	37
3.6 Quality Assurance / Quality Control (QA/QC).....	39
CHAPTER 4 EFFECT OF SECONDARY TREATMENT TYPE ON ESTROGEN REMOVAL IN WASTEWATER TREATMENT PLANTS	49
4.1 Introduction	49
4.2 Materials and Methods	51
4.3 Results and Discussion.....	53
4.3.1 Estrogen Analysis with ELISA.....	53
4.3.2 Effect of Secondary Treatment Type on Estrogen Removal	56
4.3.3 Comparison of Secondary Treatment Units	62
CHAPTER 5 EFFECT OF SLUDGE HANDLING PROCESSES ON ESTROGEN CONCENTRATION IN WASTEWATER SLUDGES	68

5.1 Introduction	68
5.2 Materials and Methods	70
5.3 Results and Discussion.....	71
5.3.1 Estrogen Analysis with ELISA.....	71
5.3.2 Change in Estrogen Concentration Due to Sludge Handling Processes.....	75
5.3.3 Mass Balance of Estrogen in Sludge Handling Processes.....	82
5.3.4 Fate of Estrogen in Sludge Handling Processes	84
CHAPTER 6 CONCLUSIONS, IMPLICATIONS AND RECOMMENDATIONS	88
6.1 Conclusions	88
6.2 Implications of Findings to Wastewater Treatment and Sludge Handling	90
6.3 Recommendations for Future Research	93
APPENDIX A ESTROGEN MASS BALANCE CALCULATIONS.....	94
A.1. Terms.....	94
A.2. Mass Balance Procedure	94
A.3. Summary of Mass Balances	103
A.4. Summary of Mass Balance Raw Data and E2 Contributions.....	106
REFERENCES	108
VITA.....	116

LIST OF FIGURES

Figure 3.1: Flow scheme of Plant A with sampling locations	29
Figure 3.2: Flow scheme of Plant B with sampling locations	30
Figure 3.3: Extraction procedure for sludge samples	34
Figure 3.4: Example graph of best-fit line for calibration curve and absorbance values for standards	39
Figure 5.1: Estrogen concentration before and after gravity thickeners	77
Figure 5.2: Estrogen concentration before and after centrifuging	77
Figure 5.3: Estrogen concentration before and after DAFT and anaerobic digestion	81
Figure 5.4: Sensitivity Analysis for Mass Balance Calculations	83
Figure A.1: Plant A, Gravity Thickener (GT 2).....	99
Figure A.2: Plant A, Anaerobic Digester (AD)	103
Figure A.3: Plant A, Gravity Thickener (GT 1).....	104
Figure A.4: Plant A, Dewatering Centrifuge (CT 2)	104
Figure A.5: Plant B, Dissolved Air Flotation Thickening (DAFT)	104
Figure A.6: Plant B, Dewatering Centrifuge (CT 3).....	105

LIST OF TABLES

Table 2.1: Structures, octanol-water partition coefficient (K_{ow}), solubility in water, E2 equivalence, and distribution coefficient (K_d) for free estrogens.....	7
Table 2.2: Structures for conjugated estrogens.....	8
Table 3.1: Overview of wastewater facility treatment trains	30
Table 3.2: Example of determining fitting parameters for calibration curve	38
Table 3.3: Results for equipment blanks.....	40
Table 3.4: Comparison of single and double extractions for dewatered sludge	43
Table 3.5: Concentration of estrogen spike standards over time	44
Table 3.6: Coefficients of variation for for ELISA analytical duplicates.....	45
Table 3.7: ELISA analytical duplicates for estrogen standards	45
Table 3.8: Recovery of estrogen for spiked samples	47
Table 3.9: Recovery of estrogen for selected steps of the method	48
Table 4.1: Analytical duplicates	55
Table 4.2: Replicate extraction samples	55
Table 4.3: Recovery experiments for extractions	56
Table 4.4: Comparison of estrogen load and removal for trickling filters.....	58
Table 4.5: Comparison of estrogen load and removal for BNR	60
Table 4.6: Comparison of estrogen load and removal for non-BNR activated sludge	62
Table 5.1: Precision for ELISA replicates	73
Table 5.2: Precision for extraction replicates	74
Table 5.3: Recovery experiments for extractions	75

Table 5.4: Input and Output Estrogen Concentrations for Mass Balance Calculations.... 87

Table A.1: Input, Output, Raw Data and E2 Contributions for Mass Balance Calculations
..... 106

CHAPTER 1

INTRODUCTION

1.1 Research Problem

Endocrine-disrupting compounds (EDCs), such as estrogen, are known to be present in the aquatic environment at concentrations that affect fish and other wildlife. Wastewater treatment plants (WWTPs) are major contributors of EDCs into the environment. EDCs are released via effluent discharge and solid waste (biosolids). In both the effluent and solids, the final concentration of the compound depends on the treatment processes and environmental conditions. This study focuses on estrogen concentration in sludge as a result of secondary treatment and sludge handling processes.

Wastewater treatment plants are major contributors of EDCs to the environment (Daughton and Ternes, 1999), as well as runoff from land where biosolids or manure has been applied (Nichols et al., 1997). Estrogens and other EDCs in the aquatic environment are known to cause developmental and reproductive problems in fish (Jobling et al., 1998) and feminization of fish at concentrations as low as a few ng/L (Länge et al., 2001). Further, the long-term effects on humans from estrogens through water consumption are not well known, but pose another possible problem. The potential impact of EDCs is widespread in the U.S. (Kolpin et al., 2002) and even affects the local area for this project (Snyder et al., 1999).

Though concentrations of various estrogens in wastewater effluent discharge have received significant attention (Ternes et al., 1999; D'Ascenzo et al., 2003; Gabet-Giraud et al., 2010), levels of estrogens in biosolids have not (Janex-Habibi et al., 2009; Suzuki and Maruyama, 2006). A compounding issue is the discrepancy regarding the amount of estrogens found in biosolids. In the study by Janex-Habibi, only 10% of the estrogens were found adsorbed to the solid phase while the study by Suzuki and Maruyama showed 30% adsorbed to the solid phase. Also, other authors expect that estrogens will show a preference for partitioning to the solid phase based on the K_{ow} partition coefficients (Gomes et al., 2004; Khanal et al., 2006). In light of an increasing trend for land application of biosolids, as opposed to landfilling, it will become even more important to monitor estrogens in wastewater sludge. There are no state or federally-mandated regulations for estrogen in biosolids. Current pollutant limits for land application of biosolids are set only for heavy metals and pathogens (e-CFR, 2011).

In this research, estrogen removal in wastewater and wastewater sludge was focused in two areas:

1.2 Issue One: Impact of Secondary Treatment Type on Estrogen Concentration for Wastewater Sludge

Secondary treatment type is known to influence estrogen removal in the aqueous phase (Ternes et al., 1999; Westerhoff et al., 2005; Joss et al., 2004; Liu et al., 2009), but estrogen removal in sludge has not received as much attention. Only a few studies have examined estrogen load on secondary sludge in full-scale WWTPs (Andersen, et al., 2003; Braga, et al., 2005b; Janex-Habibi, et al., 2009; Joss, et al., 2004; Muller, et al., 2008;

Muller, et al., 2010; Ternes, et al., 2002) and one study involved a pilot-scale plant (Esperanza, et al., 2007).

Comparison of estrogen load between treatment types for secondary sludge is difficult due to different analytical strategies and different wastewater sources. A variety of methods have been used to extract estrogen from sludge, including sonication, shaking, solid-phase extraction and vortexing (Esperanza, et al., 2007; Gabet-Giraud, et al., 2010b; Muller, et al., 2008; Ternes, et al., 2002) and recovery varies for the method and solvents used. Also, some analytical methods quantify natural estrogens separately or combined and the reporting limits are not always included. Estrogen load on secondary sludge among different WWTPs is difficult to compare because the feed wastewater and primary treatment may vary and the effects of secondary treatment type cannot be isolated. This study uses a consistent extraction step and measures total deconjugated natural estrogens. Additionally, both WWTPs receive wastewater from the same city and have similar primary treatment. This will allow for a direct comparison of estrogen removal in sludge due to different secondary treatment types.

1.3 Issue Two: Impact of Sludge Handling Processes on Estrogen Concentration for Wastewater Sludge

The effect of sludge handling processes on estrogen removal in sludge is not well established. In previous studies, it has been shown that the type of wastewater treatment affects estrogen removal in the effluent (Ternes et al., 1999; Westerhoff et al., 2005; Joss et al., 2004; Liu et al., 2009). Similar research is needed for sludge handling processes. In one report, it seems that anaerobic vs. aerobic treatment may affect the concentration of estrogens in the sludge (Janex-Habibi et al., 2009). However, this study involves different

treatment plants and different locations, and therefore a direct comparison cannot be made. In order to isolate the effect of sludge handling, a singular wastewater source is needed. In this study, estrogen removal will be investigated for wastewater sludge samples, which have undergone various sludge handling processes, from two WWTPs receiving wastewater from the same city. The information gathered will serve to determine the effect of sludge handling processes on estrogen removal.

1.4 Research Objectives and Hypotheses

This research aimed at investigating the impact of secondary treatment processes and sludge handling processes on estrogen removal in various sludges from two WWTPs (Plant A and Plant B) with the same municipal wastewater source.

The facilities differ in the secondary treatment and sludge handling processes. Plant A treatment processes include: primary sedimentation, gravity thickening, trickling filters and nitrification, activated sludge with biological nutrient removal (BNR), anaerobic digestion, and centrifuging. Plant B treatment processes include: primary sedimentation, gravity thickening, BNR, dissolved air flotation, and centrifuging.

Issue one addresses secondary treatment processes. It was hypothesized that Plant A trickling filter sludge would have a greater concentration of estrogen. Since there are fewer solids in the trickling filter treatment, adsorption would be greater on a mass basis. Also, trickling filters have been shown to have lower biodegradation of estrogen as compared to other secondary treatment processes, so there would be a greater likelihood for adsorption due to the higher concentration of estrogen. It was hypothesized that BNR, which is found in both facilities, would show the lowest concentrations of estrogen in the

sludge because the SRT is higher and this provides a longer time for biodegradation to occur.

In Issue two, it was hypothesized that mechanical processes, such as centrifuging, gravity thickening and dewatering, would not affect the estrogen concentration because these processes do not assist with biodegradation or interfere with adsorption. On the other hand, it is anticipated that anaerobic digestion in Plant A will have the greatest impact on the estrogen concentration since the microorganisms will break down solids on which estrogen is adsorbed. Also, dissolved air flotation thickening in Plant B may decrease estrogen in the sludge because aeration promotes microbial biodegradation.

CHAPTER 2

STATE OF THE KNOWLEDGE

2.1 Natural, Synthetic and Metabolite Forms of Estrogen

Estrogen exists in natural and synthetic forms which have a four-ring or tetracyclic composition with differences on the cyclopentane ring at positions C16 or C17 (Table 2.1). Natural forms of free estrogen include estrone (E1), 17 α -estradiol (α E2), 17 β -estradiol (E2), and estriol (E3). Through metabolic reactions, E1, E2 and E3 are interconverted as a result of their similar structures. The synthetic form of estrogen found in many birth control pills is ethinyl estradiol (EE2). Estrogen is also found in conjugated forms (Table 2.2). In addition to the differences in structure, the other major differences between free and conjugated estrogens are that free estrogens are biologically active while conjugated estrogens are not, and conjugated estrogens are much more water soluble. Of the natural estrogens, E2 is the most potent and the potency of other estrogens is equated to E2 through their E2 equivalence.

Conjugation is a metabolic process that occurs through esterification of free estrogen by glucuronide (G) or sulfate (S). The changes occur in either the phenol or cyclopentane rings at positions C3, C16 or C17 where there is a hydroxyl group (Khanal, et al., 2006). Glucuronidation takes place mainly in the liver and helps with the elimination of estrogens from the body. The enzymes responsible are from the UDP-glucuronosyltransferase family. Sulfonation requires the enzyme sulfotransferase.

Table 2.1: Structures, octanol-water partition coefficient (K_{ow}), solubility in water, E2 equivalence, and distribution coefficient (K_d) for free estrogens.

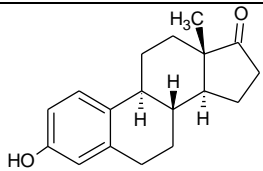
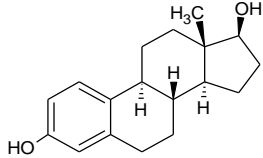
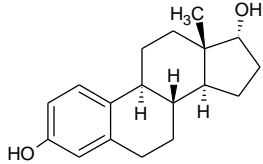
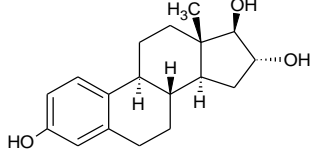
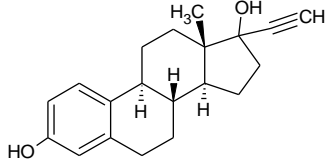
Estrogen Type (Abbrev)	Chemical Structure	Log K _{ow}	Sol. in water (mg/L)	E2 Equiv.	Log K _d	Reference
Estrone (E1)		3.1 – 3.4	0.8 – 12.4	0.1 – 0.2	2.78 1.98 – 3.22	(Ternes, et al., 1999a) (Chen and Hu, 2010) (Chiu, et al., 2009)
17 α -estradiol (α E2),		3.2 – 13.3	3.4 – 4.0	1 – 2		(Lai, et al., 2002)
17 β -estradiol (E2)		5.4 – 13.3	3.8 – 4.0	1	2.61	(Lai, et al., 2000) (Chen and Hu, 2010)
Estriol (E3)		3.2 – 13.3	2.6 – 2.8	0.02	1.31 – 2.79	(Lai, et al., 2000) (Chiu, et al., 2009)
Ethinyl estradiol (EE2)		4.15	4.8	1.81	2.00 – 3.81	(Lai, et al., 2002) (Stanford and Weinberg, 2010) (Chiu, et al., 2009)

Adapted from Khanal et al., 2006

Table 2.2: Structures for conjugated estrogens

Estrogen Type	Chemical Structure	Estrogen Type	Chemical Structure
E1-3S		E2-17G	
E1-3G		E3-3S	
E2-3S		E3-3G	
E2-3G		E3-16G	

Estrogen is inactive in the sulfate form and may remain in the blood, but can be reactivated when it is needed. Estrogen sulfates remain in the body much longer than estrogen glucuronides. In general, estrogens are transported throughout the body more easily in the conjugated form (Raftogianis, et al., 2000).

Deconjugation of estrogen glucuronide and estrogen sulfate occurs through hydrolysis in the presence of enzymes. These enzymes are glucuronidase and sulfatase. Glucuronidase is usually not present in the human body except if pathogenic bacteria are in the intestine. Sulfatase is the antagonistic enzyme to sulfotransferase. It is present in the human body and the two enzymes act in balance to regulate the amount of active estrogen available (Douglas Hall, n.d.).

2.2 Effect of Estrogen as an Endocrine Disrupting Compound

An endocrine disrupting compound (EDC) is defined by the United States Environmental Protection Agency (U.S. EPA) as an “exogenous agent that interferes with the production, release, transport, metabolism, binding, action, or elimination of the natural hormones in the body responsible for the maintenance of homeostasis and the regulation of developmental processes” (U.S. EPA, 2011). A wide variety of chemicals are considered EDCs, including many pesticides, plasticizers, hormones, and industrial chemicals.

Estrogens and estrogenic chemicals make up a significant fraction of EDCs. In addition to the steroidal estrogens previously mentioned (e.g., estrone, estradiol, estriol) there are nonsteroidal estrogens. Nonsteroidal estrogens are further classified into xenoestrogens, phytoestrogens, and mycoestrogens. Xenoestrogens are synthetic chemicals that mimic estrogen. Some of the most notorious chemicals are phthalates,

polychlorinated biphenyls (PCBs), dichlorodiphenyltrichloroethane (DDT), and bisphenol A. Phytoestrogens are natural, plant-derived chemicals that have common structural components (i.e. phenolic ring, hydroxyl groups) and molecular weight with steroidal estrogens. Animals are exposed to phytoestrogens as a part of their diet. The most active ones are coumestans, prenylated flavonoids and isoflavones. Mycoestrogens are produced by fungi. The most active one is zearalenone. It is usually associated with stored grain.

Humans and nearly all groups of wildlife are impacted by EDCs. In humans, EDCs have been linked to reduction in sperm count, increased incidence of cancer (e.g., testicular, prostate, breast), congenital malformations, and neurological effects (Phillips and Harrison, 1999). Effects on other animals were noticed as early as the 1950s. In wildlife, documented instances of fertility problems in several mammals, eggshell thinning in birds, deformed embryos in reptiles, and intersex changes in fish are clear examples of the harmful effects of EDCs (Phillips and Harrison, 1999).

Environmental exposure to estrogen in particular, both natural and synthetic, has been shown to alter the developmental and reproductive processes of some wildlife, especially aquatic life. For example, juvenile male fish exposed to estrogen will synthesize vitellogenin, which is a female-specific protein. Estrogen exposure is also linked to sex reversal, intersexuality, and inhibition of gonadal growth (Jobling, et al., 1998).

The “activity” or potential to disrupt to the endocrine system varies for EDCs. Estrogen is a very potent EDC. Concentrations as low as a few ng/L can affect fish (Routledge, et al., 1998). Although some industrial phenols, such as bisphenol A (BPA),

octylphenol and nonylphenol, are found in higher $\mu\text{g/L}$ concentrations compared to ng/L concentrations of natural estrogens, industrial phenols have a much lower activity and therefore have less of an impact (Gunnarsson, et al., 2009).

2.3 Presence of Estrogen in Wastewater Treatment

Exposure to estrogen may occur through several routes. Potential sources for humans include food, pharmaceuticals, and drinking water (Phillips and Harrison, 1999). For aquatic life, exposure is attributed mainly to wastewater discharge and, to a lower degree, from the application of wastewater sludge (biosolids) to land, run-off from fields, and run-off or discharge from animal feedlots. Clear evidence exists that the adverse effects on aquatic species, as described in the previous paragraph, occur in vicinity of wastewater effluent discharge (Jobling, et al., 1998). Therefore it is important to target wastewater treatment as the main environmental source of estrogen.

Estrogens are released from the body mainly through urine and in conjugated forms. A small amount of estrogen, 5-10% of the total estrogen excreted, is released through feces and in the form of free estrogen (Adlercreutz and Järvenpää, 1982). Deconjugation of estrogen in wastewater starts right away in septic tanks and during transport in the sewer lines. This was shown by comparing female urine, wastewater in collection tanks, and wastewater influent. Even before initial wastewater treatment processes, there was evidence of deconjugation as shown by increased concentrations for free estrogen and decreased concentrations of conjugated estrogens (D'Ascenzo, et al., 2003). This same study demonstrated that estrogen glucuronides are more quickly deconjugated than estrogen sulfates and there was a higher level of E3 as compared to E2 and E1. Estrogen sulfates undergo very little deconjugation during wastewater treatment and over 74% are

still present after the activated sludge process (Gomes, et al., 2009). Deconjugation occurs due to β -glucuronidase and arylsulfatase enzymes. *Escherichia coli*, commonly found in wastewater, can synthesize β -glucuronidase in high amounts (Shackleton, 1986). This may explain the faster deconjugation for glucuronides as compared to sulfates. Deconjugation may also occur during wastewater treatment and therefore may increase the concentration of active estrogens (Khanal, et al., 2006).

Analysis of wastewater treatment plants around the world has established that there are ng/L levels (>1 up to 670) of estrogen in the influent and effluent (Table 2.3). Although some wastewater treatment processes eliminate a significant portion of free estrogens, there is frequently estrogen released in the final effluent. In general, E1 and E3 make up the greatest fraction in influent and E1 makes up the greatest fraction in effluent. E2 is usually found at low levels in the effluent as a result of transformation to E1 (Combalbert and Hernandez-Raquet, 2010). In some cases, effluent estrogen concentrations have been reported to be higher than influent estrogen concentrations. This is attributed to estrogen deconjugation, as described earlier.

Table 2.3: Selected examples of estrogen concentrations in wastewater treatment plant influent and effluent.

Estrogen	Location	Unit	Influent	Effluent	Reference
E1	United States	ng/L	57.8 – 83.3	6.3 – 49.1	Robert et al., 2007
	Austria	ng/L	29 – 670	0 – 72	Clara et al., 2005
	Japan	ng/L	259 – 326	0 – 17	Kobayashi et al., 2006
	France	ng/L	18.8 – 170	0.1 – 58	Gabet-Giraud, et al., 2010a
E2	United States	ng/L	11.2 – 161.6	1.5 – 5.4	Robert et al., 2007
	Austria	ng/L	23 – 660	0 – 275	Clara et al., 2005
	Japan	ng/L	0 – 57	4.6 – 14	Kobayashi et al., 2006
	France	ng/L	6 – 48.9	1.1 – 21.4	Gabet-Giraud, et al., 2010a
E3	United States	ng/L	79.7 – 259.2	2.2 – 3.9	Robert et al., 2007
	Austria	ng/L	23 – 660	0 – 275	Clara et al., 2005
	Japan	ng/L	0	0 – 151	Kobayashi et al., 2006
	France	ng/L	26.8 – 658	5.2 – 47.7	Gabet-Giraud, et al., 2010a

Adapted from Liu, et al., 2009

Note: Concentrations are for free estrogens and do not include conjugated estrogens

2.4 Removal Mechanisms for Estrogen in Wastewater Treatment

Estrogen is removed during wastewater treatment through biodegradation, adsorption and chemical oxidation. Estrogen removal has been investigated to some extent for both conventional wastewater treatment and advanced treatment. Most studies have focused solely on estrogen in the aqueous phase.

During conventional wastewater treatment, estrogen removal is greatest during secondary treatment. In general, estrogen is not removed during primary treatment (Braga, et al., 2005a; Holbrook, et al., 2002; Muller, et al., 2008; Ternes, et al., 1999b). Most removal of estrogen takes place during secondary treatment, which is typically done with activated sludge in the U.S. Activated sludge has been shown to have better estrogen removal than trickling filters, but trickling filters have better estrogen removal than treatment by chemical precipitation (Ziegler, et al., 2005; Svenson, et al., 2003; Ternes, et al., 1999).

Khanal, et al. (2006) suggested that the main factors in determining estrogen removal for activated sludge systems are solids retention time (SRT), the estrogen partition coefficient (K_d), and the biodegradation constant. A longer SRT would increase estrogen removal for activated sludge systems. This was demonstrated by Ternes, et al. (1999a) when the SRT was increased from 6 to 11 days and the removal for E2 and E1 improved by 21% and 30%, respectively. The estrogen partition coefficient could be increased by having higher mixed liquor suspended solids (MLSS). When MLSS was increased from 1000 to 10,000 mg/L, estrogen removal increased significantly (Khanal, 2006). Also, higher MLSS would increase the biodegradation constant and result in increased removal.

Although estrogen is not eliminated through adsorption to sludge, it is commonly considered a removal process in wastewater treatment. Estrogen adsorbs to sludge to some extent, which is expected based on the distribution coefficients for estrogens, but published studies show very different results. Several groups report that <10% (Muller, et al., 2008) of the total estrogen is adsorbed to sludge during wastewater treatment

(Andersen, et al., 2003; Janex-Habibi, et al., 2009; Joss, et al., 2004; Muller, et al., 2008) and other research has shown that sludge has a high capacity to adsorb estrogen (Clara, et al., 2004; Ren, et al., 2007b).

Estrogen removal may also take place during advanced treatment, including activated carbon treatment, membranes, ozonation, chlorination, and photodegradation. Granular activated carbon (GAC) has high absorption for E2 at around 80%; however, the removal efficiency is linked to the initial concentration. When the initial concentration decreased from 100 to 1 ng/L, removal dropped from 81% to 49% (Snyder, et al., 2003). Since estrogen concentrations are often found at the low ng/L level, GAC may not be suitable for estrogen removal. Powdered activated carbon (PAC) removes 90% of estrogen and can remove even more with longer retention times. Unfortunately, new PAC must be supplied continually, so it would be a very expensive treatment if conducted on a continuous basis (Yoon, et al, 2005).

Estrogen removal by a membrane bioreactor (MBR) can reach 82% for E1, E2, and EE2 (Liu, et al., 2005). As described earlier, a longer SRT and higher MLSS can improve removal. Although the pores of a membrane are small, even an ultrafiltration membrane is 100 to 10,000 times larger than estrogen molecules, so it is possible for estrogen to pass through the membrane and be present in the effluent. Estrogen removal with an MBR occurs through adsorption to solids and subsequent biodegradation. Increasing MLSS will increase adsorption and, ultimately, increase estrogen removal (Khanal, et al., 2006).

Oxidation is another approach to remove estrogen. Both ozone and chlorine have been used as oxidants. Typical treatment plant ozone dosages (10-50 mg/L) will remove

essentially 100% of estrogen; however, a 2 µg/L ozone dosage achieved 95% E1 and E2 removal (Deborde, et al., 2005). A possible problem with ozonation is the formation of byproducts that could be harmful (Petala, et al., 2008). Photodegradation with direct UV, UV/H₂O₂, and UV/TiO₂ have also been shown to oxidize estrogen. The combination of UV/TiO₂ requires the least amount of energy (Khanal, et al., 2006). Chlorine is already used as a disinfectant and it can also oxidize some organics. Compared to ozone and UV combinations, chlorine is not as effective at oxidizing organics (Liu, et al., 2009).

2.5 Analytical Methods for Determining Estrogen Potency

There are many methods to choose from in order to evaluate the presence or effect of estrogen. To choose an appropriate method, one must first consider the purpose of the information to be acquired. Estrogen potency analyses provide information on the effect of one or more chemicals to the endocrine system. These analyses are particularly useful when working with a mixture of chemicals, when determining toxicity, or when qualitative information is desired.

In vitro assays are a fairly rapid way to determine if a chemical or mixture of chemicals has an estrogenic effect. These tests are usually easier than *in vivo* tests and have clearly understood pathways. Some *in-vitro* biological assays require specialized cell lines to measure receptor binding and gene expression. Examples include the MLVN assay, receptor binding assay (RBA), and estrogen responsive activated luciferase (ER-CALUX). Concentrations are detected to the ng/L and pg/L level (Houtman, et al., 2006; Snyder, et al., 2003a). *In-vivo* bioassays monitor bioindicators after the organism has been exposed to estrogen for a specific period of time. Typical bioindicators include

vitellogenin, hormone production, reproductive behavior, and gonad development (Snyder, et al., 2003b).

Other biological assays use yeast that has an estrogen receptor integrated into the chromosome, often called the yeast estrogen screen (YES) assay. When the receptor binds to a ligand, the gene is expressed and an enzyme is produced. The enzyme reacts with a substrate and causes a color change. After incubation, the absorbance is measured and related to a concentration based on known standards (Routledge and Sumpter, 1996). Similarly, a chemiluminescent enzyme immunoassay (CLEIA) uses gene expression; however the signal is provided by a chemiluminescent agent rather than a color-changing substrate (Roda, et al., 2006).

2.6 Analytical Methods for Determining Estrogen Concentration

In contrast to bioassays, there are methods that provide a direct measurement of estrogen concentration using instrumentation. The two most common methods use a separation technique, gas chromatography (GC) or liquid chromatography (LC), coupled with mass spectrometry (MS). Detection limits can be as low as picogram per liter when samples are extracted and concentrated. An enzyme-linked immunosorbent assay (ELISA) is a quicker and less costly quantitative tool, which has comparable detection limits after sample concentration. While quantification is very accurate, these methods do not provide information about toxicity.

Many of the emerging contaminants found in water systems are at $\mu\text{g/L}$ or lower levels. In order to detect these substances, they need to be concentrated. One way to do this is through extraction and the most common type is solid-phase extraction (SPE). Liquid-liquid, Soxhlet, steam distillation, solid-phase microextraction (SPME), and

semipermeable membrane devices (SPMDs) are other types that have been used (Snyder, et al., 2003a; Vanderford, et al., 2003). In SPE, the water sample is pulled through a column, cartridge or disk, often by way of vacuum aspiration. The compounds are retained by the column and then eluted using solvents (Snyder, et al., 2003a). SPE is also performed on solid matrices, such as sludge. In this case, the solvents are applied directly to the dried sample in a container. The solvents are then concentrated by evaporation under nitrogen. In this manner, estrogen is concentrated by two or three orders of magnitude.

The choice between GC and LC depends on the volatility of the compound. In the case of GC, this method does not perform well with compounds that are highly polar or thermally labile. These compounds need to be altered through a process called derivatization. After the compound has been modified with another chemical agent, it is less polar and more volatile, which allows analysis by GC. This procedure requires extra chemicals, significant time, additional cleanup, and disposal of hazardous chemicals (Snyder, et al., 2003a). Derivatization is not possible for some compounds, such as caffeine, which do not have the necessary functional groups in their structure. LC does not require derivatization and can accommodate the compounds that GC cannot.

Both GC and LC separate the compounds within a sample using the same principle, which is the affinity of the analyte to the column. The processes differ in the phase of the analyte prior to detection. For GC, a compound is injected into the instrument and vaporized. The vapor is transported by an inert carrier gas. With LC, the analyte remains in the liquid phase and is carried via a mobile phase.

ELISA kits have been developed for the detection of estrogen in environmental water samples. The ELISA test detects the presence of an antigen or antibody by enzyme linking. The signal, usually a color change or fluorescence, is proportional to the amount of antigens or antibodies in the sample (Snyder, et al., 2003a). In a study by Li, et al. (2004) an ELISA was created for the detection of estrone in water sources. The method used SPE and tested 3 antibodies. The results were compared to HPLC and GC and found to be very close at the ng/L level (Li, et al., 2004). Subsequent studies have compared ELISA and LC-MS and found the methods to give comparable results, although ELISA often reports a higher value than LC-MS (Farre, et al., 2006; Hintemann, et al., 2006).

2.7 Quality Assurance and Quality Control Considerations

Quality assurance and control (QA/QC) is the backbone of a good, scientific process. For PPCPs and EDCs, there are important QA considerations to take into account in order to accurately measure to the ng/L level. First, all equipment requires an extensive cleaning process. Since the target compounds may be at trace levels in water, only ultra-pure water should be used for cleaning, sample preparation, and dilution. Plastic equipment should be avoided since some compounds from the plastic industry are EDCs and may result in cross-reactions for non-quantitative tests. Most studies use glass or amber glass (Boyd, et al., 2003). It may be necessary to heat the containers to high temperatures to oxidize any trace organics. Extraction disks and cartridges need to be rinsed with the chosen solvents prior to use. Prior to testing the first samples, blanks should be completed for the entire methodology to ensure that no sources of contamination exist.

The highest quality reagents and standards must be used and should be tested for trace levels of the analyte being studied. An internal standard should be chosen to measure concentration in instrumentation analysis. The internal standard needs to remain unchanged and should not be absorbed or diluted in any process. Reference standards should be checked for degradation. If this occurs, then the standard must be prepared fresh for each use. Also, some samples will degrade if they are not preserved (Vanderford, et al., 2003). This means sample collection and lab preparation must be timed appropriately so that neither the standards nor the samples sit too long before analysis.

Further considerations include replicate tests, pre-treatment of samples, and matrix effects for mixed samples. Replicates ensure that the results are repeatable and reliable. Chlorinated water samples may need pre-treatment to avoid reactions with reference standards (Boyd, et al., 2003).

2.8 Secondary Wastewater Treatment Processes

Secondary wastewater treatment focuses on biological processes to remove dissolved organic matter. There are many different designs that range from classic techniques, such as stabilization ponds, to emerging technologies, such as membrane bioreactors. This study involves three common processes: trickling filters, activated sludge, and biological nutrient removal.

2.8.1 Activated Sludge

Activated sludge is an aerobic suspended-growth process that uses microorganisms to biodegrade dissolved organic material in the wastewater. The microorganisms utilize the organics for cell synthesis and for an energy source. The goal in removing dissolved

organics is to minimize oxygen depletion in surface water (i.e., biological oxygen demand or BOD) after treated wastewater is discharged. Key features of the activated sludge treatment process include a large basin to contain the wastewater and microorganisms, constant aeration to maintain aerobic conditions, clarification to separate the effluent and microorganisms, return of some microorganisms to the basin, and wasting of some microorganisms as secondary sludge.

Aeration is essential for BOD removal through biodegradation. Heterotrophic bacteria, which constitute the majority of the microorganisms in activated sludge treatment, require oxygen as an electron acceptor. Oxygen is provided via mechanical aerators or gas diffusers. The biodegradation rate is directly related to the amount of oxygen available to the microorganisms.

The sludge retention time (SRT) is an important operating parameter. SRT is the average time that the microorganisms stay in the activated sludge process before it is wasted. To maintain a constant SRT, the amount of microorganisms wasted should equal the amount formed.

2.8.2 Biological Nutrient Removal

Biological nutrient removal (BNR) is an activated sludge process that has been modified in order to reduce both phosphorus and nitrogen. In addition to an aerobic zone, BNR also has anaerobic and/or anoxic zones. Nitrification and phosphorus removal occur in the aerobic zone, but the anaerobic zone is necessary to cultivate phosphorus-accumulating organisms (PAOs).

Nitrification is a two-step biological process where ammonia is oxidized to nitrite and then nitrate. Not all WWTPs require ammonia removal, but ammonia is toxic to

aquatic organisms and therefore must be eliminated before discharging to surface water or other environmentally-sensitive areas. Nitrification can be achieved along with BOD removal in a single-sludge system or it can be accomplished separately from BOD in a two-sludge system. For BNR, a single-sludge system is used. Nitrifying bacteria oxidize ammonia in the aerobic zone of BNR.

Phosphorus removal is accomplished by manipulating PAOs to either release or store phosphorus depending on the presence or lack of oxygen. In the anaerobic zone, PAOs assimilate volatile fatty acids (VFAs) or other fermentation products and release phosphorus. Upon entering the aerobic zone, PAOs oxidize the stored VFAs and uptake phosphorus (Metcalf & Eddy, 2003). This removes phosphorus from the effluent, where it could contribute to eutrophication of surface water.

2.8.3 Tricking Filters

A trickling filter is a biological treatment unit categorized as a nonsubmerged attached-growth process. Microorganisms create a biofilm on the media, which can be plastic or rock. Wastewater is sprayed over the media and contacts the biofilm as it trickles down. Trickling filters are mainly used for BOD removal and result in low nitrification.

Trickling filters produce a low amount of sludge. Biofilm will eventually break off, called sloughing, and new biofilm will grow in its place. If biofilm sloughing did not occur, the SRT for trickling filters would be infinite. Calculating the actual SRT is difficult, so it is usually estimated based on BOD loading (Metcalf & Eddy, 2003). The biofilm is concentrated in a secondary clarifier and the solids may be returned to the head

of the plant or it may be mixed with other solids and treated with sludge handling processes.

2.9 Sludge Handling Processes

Wastewater treatment intentionally results in the separation of solids from the liquid stream. The solids are treated in preparation for disposal, which may be for beneficial utilization, incineration or placement in a landfill. A main goal of sludge handling processes is to remove excess water in order to reduce the total volume of the sludge. This reduces disposal costs, especially for transportation, and when recycle streams are used, it also increases the net amount of finished water. Wastewater treatment plants in this study used thickening, mechanical dewatering, and digestion.

2.9.1 Sludge Thickening

Thickening occurs after solids are removed from a clarifier. This step increases the solids concentration from around 1% to 2-10% depending on the type of sludge and the thickening process used (McFarland, 2001). In this study, one WWTP used a gravity thickener for primary sludge and another WWTP used dissolved-air flotation for secondary sludge.

A typical gravity thickener is a basin with a sloped bottom to collect the sludge in the center. A mechanical scraper moves along the sloped bottom to direct the thickened sludge to the draw-off pipe. Solids settle due to gravitational forces, although other settling mechanisms (i.e., discrete and hindered settling) affect the final solids concentration. Polymers or other coagulants may be added to assist in forming flocs that settle. The effluent or overflow leaves the thickener over a weir at the top of the basin and usually returns to the head of the WWTP via a return stream.

Dissolved-air flotation thickening (DAFT) is a process that uses pressurized air to force solids upward. In opposition to clarifiers and gravity thickeners, the solids are concentrated on the surface of the water. A skimmer continuously removes the floating solids from the surface. Polymers may be added to assist in aggregation of the solids. The supernatant leaves at the bottom of the basin and usually returns to the head of the WWTP via a return stream.

2.9.2 Mechanical Dewatering

Mechanical dewatering is the use of equipment to remove excess water from sludge. In contrast, non-mechanical dewatering systems, such as drying beds, involve sedimentation and natural air drying to remove water from sludge. Low-pressure mechanical dewatering systems include centrifuges, belt presses and vacuum filters. The final solid product, often called cake, is usually 15 to 25 percent solids. High-pressure systems include plate-and-frame filter presses and diaphragm filter presses. The final cake is usually 30 to 45 percent solids (Letterman, 1999). In this study, only low-pressure systems (e.g., centrifuges) were examined.

Centrifuges use simple physics to exert a force on the sludge through rotation. As compared to conventional sedimentation, where particles settle under the force of gravity, centrifuges use rotational speed to reach forces of 1500 to 4000 times the force of gravity (Letterman, 1999). A typical type of centrifuge is the solid-bowl-decanter. Sludge is fed into the centrifuge along with polymers that assist with formation of the cake. The solids settle against the wall of the rotating bowl and are pulled to the narrower end of the centrifuge by a helical conveyor. The liquid, called centrate, leaves through the larger end and usually returns to the head of the WWTP via a return stream.

2.9.3 Sludge Digestion

Digestion is a microbial degradation process where organic matter is converted to carbon dioxide, methane and water, depending on the conditions (i.e., anaerobic or aerobic). The result is a volume reduction of 40-60% and a stabilized sludge with low volatile organic content. Digestion also reduces pathogens. The solids concentration is 2-4% after digestion. Another advantage of this process is that dewatering is more effective on digested sludge. Volatile solids tend to adsorb more water and since digested sludge has a reduced amount of volatile organics, it has a reduced ability to hold water (McFarland, 2001).

Anaerobic digestion occurs when molecular oxygen is not available to the microorganisms. Organic matter is converted to methane gas, carbon dioxide gas, and water. The process usually requires 15 to 40 days. Methane, which is typically 60-70% of the gas produced by volume, can be burned as biogas (McFarland, 2001). There are four main steps in anaerobic digestion: hydrolysis, fermentation, acetogenesis, and methanogenesis. Various microbial populations are responsible for each step; therefore, a careful balance between each group is necessary. Digestion is particularly sensitive to pH, temperature, and organic loading. If proper conditions are not maintained, the system fails and stabilized sludge is not achieved. Anaerobic digestion is useful for both primary and secondary sludges. The digested sludge moves on to the dewatering system and the supernatant is returned to the secondary or primary treatment via a return stream.

Aerobic digestion is the oxidation of organic matter to carbon dioxide and water. This system requires a constant input of oxygen. Unlike anaerobic digestion, there is no methane produced and, consequently, no biogas generated. The process typically lasts 10

to 20 days, which is shorter than anaerobic digestion. Energy costs are higher due to constant aeration and mixing, but the system is less prone to upsets compared to the anaerobic system. In aerobic digestion, microorganisms utilize whatever substrate is available. Since most of the useful substrate was biodegraded during secondary treatment, there is not much available. Microorganisms then go through endogenous respiration where they metabolize their own cellular mass. What remains in the end is a sludge comprising cell wall materials and other cellular components that are not easily biodegraded. Aerobic digestion systems work best for secondary sludge, which is composed of mainly microorganisms. Some of the digested sludge is recycled back to the digester. The remaining digested sludge moves on to the dewatering system and the supernatant is returned to the secondary or primary treatment via a return stream.

2.10 Return Streams

Most solids handling processes will result in a return stream or sidestream. Return streams contain a high amount of organic matter and, unless a discharge permit is obtained, it is necessary to return the stream to the WWTP for treatment. Another reason for treating return streams is to increase the net production of effluent. Return streams need to be taken into account during the design of the WWTP in order to not overwhelm any particular step of the treatment train. Although the streams may seem small in comparison to the raw water, the additional load due to return streams is significant and could increase the solids by 50-100% (McFarland, 2001). In addition to organic matter, reeturn streams may have high concentrations of pathogens or metals (Letterman, 1999).

The water quality of the return stream may dictate where in the wastewater treatment process the return stream is sent in order to provide the best treatment. Return

streams with a high concentration of suspended solids should be routed to the primary clarifier for settling. Any dissolved organics would be treated in subsequent processes. Return streams with mainly dissolved organic matter should be sent to the secondary treatment step for biodegradation.

Sometimes a stream should not be recycled directly within the WWTP. If the return stream contains a substance that does not break down easily, such as non-biodegradable chemical oxygen demand (COD), or may harm beneficial microorganisms, such as metals, or will impair the effluent water quality, such as nitrogen and phosphorus, the return stream may require separate treatment (McFarland, 2001). In this case, the return stream would not be directed to the head of the plant. Possible treatment options include precipitation, activated carbon, and air stripping (for carbon dioxide in digester supernatant).

CHAPTER 3

METHODOLOGY

3.1 Wastewater Treatment Facility Overview

Samples were collected at two full-scale municipal wastewater treatment facilities (Plant A and Plant B) which receive wastewater from the same city. An overview of the treatment trains for the two facilities is presented in Table 3.1.

Plant A (Figure 3.1) has two streams which differ in secondary treatment, but have the same primary sedimentation, tertiary direct filtration, and chlorine disinfection. One stream has trickling filters for biological oxygen demand (BOD) removal followed by nitrification as secondary treatment units while the other stream uses activated sludge with anaerobic/aerobic stages to accomplish BOD and biological nutrient removal (BNR). The solids from primary sedimentation are sent to gravity thickeners. The waste activated sludge (WAS) from nitrification and BNR are combined and then centrifuged. Solids from the trickling filter's secondary clarifiers are returned to the head of the plant. The thickened primary and secondary sludges undergo anaerobic digestion and the digested sludge is dewatered through centrifuging. Return streams from the gravity thickeners, final dewatering centrifuge, and tertiary filters are sent to the head of the plant. The centrate from the secondary WAS centrifuge is returned just ahead of the nitrification basins.

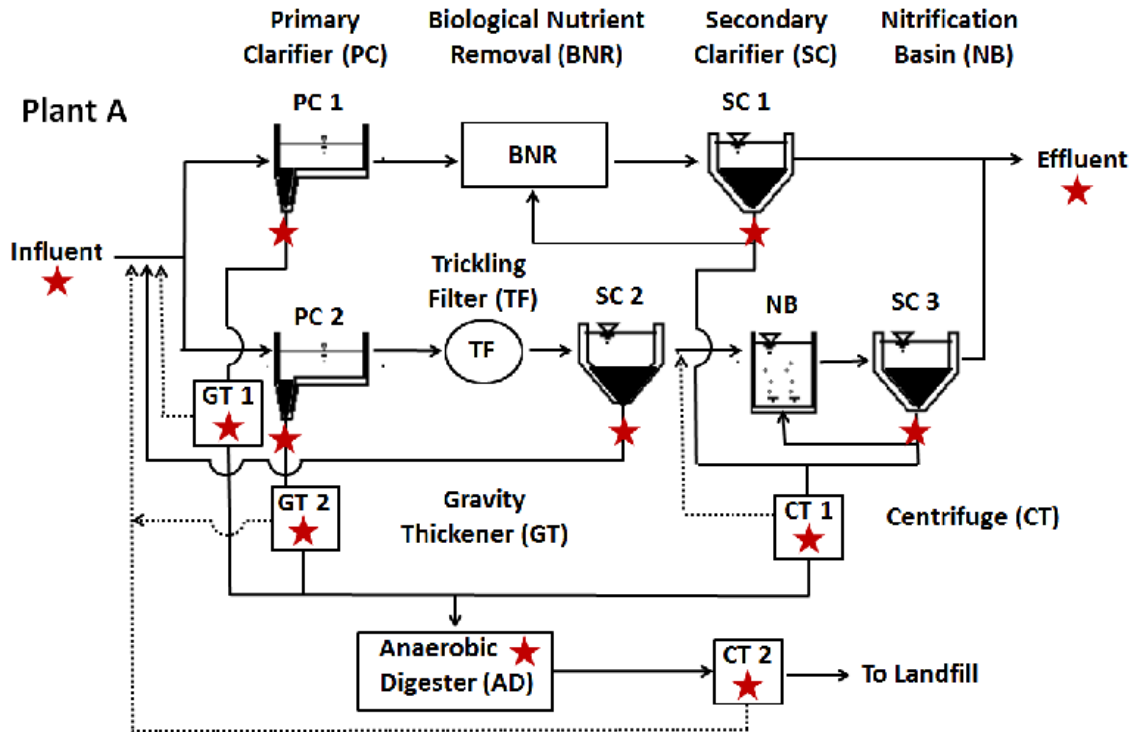

Figure 3.1: Flow scheme of Plant A with sampling locations (*)

Note: Dotted lines are return streams

Plant B (Figure 3.2) has primary sedimentation, secondary activated sludge, tertiary flocculation/filtration, and disinfection by ultraviolet light (UV). The secondary activated sludge treatment accomplishes BOD and nutrient removal through anaerobic and aerobic stages, which results in phosphorus removal, nitrification and partial denitrification. The solids from primary sedimentation are sent to gravity thickeners. The secondary WAS undergoes dissolved air flotation thickening (DAFT). The thickened primary and secondary sludges are combined and dewatering through centrifuging. Return streams from the gravity thickeners and centrate from the centrifuges return to the head of the plant. The return stream from DAFT returns just ahead of secondary treatment.

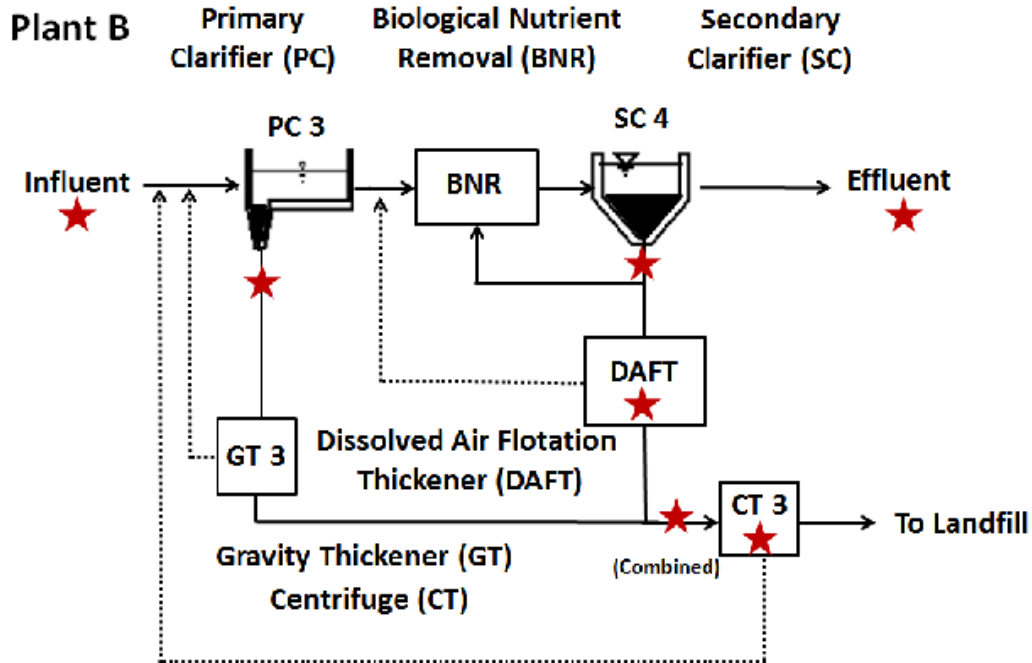

Figure 3.2: Flow scheme of Plant B with sampling locations (*)

Note: Dotted lines are return streams

Table 3.1: Overview of wastewater facility treatment trains

Facility	Primary Treatment	Secondary Treatment	Nitrogen Removal	SRT, Secondary	Sludge Treatments
Plant A, Stream 1	Sedimentation	a) Trickling Filters / b) Nitrification	Nitrification	a) 2.5 days* b) 8 days	Gravity Thickener, Centrifuge, Anaerobic Digestion
Plant A, Stream 2	Sedimentation	Activated Sludge (BNR), Anaerobic and Aerobic Stages	Nitrification / Partial Denitrification	8 days	Gravity Thickener, Centrifuge, Anaerobic Digestion
Plant B	Sedimentation	Activated Sludge (BNR), Anaerobic and Aerobic Stages	Nitrification / Partial Denitrification	5-8 days	Gravity Thickener, Centrifuge

* Equivalent SRT as determined by BOD loading (Metcalf & Eddy, 2003)

3.2 Collection and Preparation of Samples

In two sampling campaigns, grab samples from Facility A and Facility B were collected between March and June 2011. Samples were not hydraulically linked by collection time and no composite samples were collected. The goal of this study was to determine general trends for estrogen fate after different treatments rather than highly accurate quantification of estrogen and therefore it was deemed appropriate to collect grab samples. Samples were collected in 500 mL high density polyethylene (HDPE) bottles and cooled during transport. Sample locations are shown in Figures 3.1 and 3.2.

Within 3 hours of the collection time, sludge samples were transferred to 50 mL plastic vials and centrifuged at 4000 rpm for 5 minutes to separate the aqueous and solid phases. The aqueous portion was decanted into a HDPE container and stored in the refrigerator at 4 °C, along with the wastewater samples (influent, effluent, and centrate) that were not centrifuged. The solid portion (sludge) was placed in a freezer at -5 to -10 °C. After at least 24 hours in the freezer, the frozen samples were dried in an oven at 90-100 °C and then ground with a ceramic mortar and pestle or pulverized with a high-speed mixer mill. The following dried sludge samples were pulverized because their texture made it impractical to grind them: PC1, PC2, GT1, GT2, PC3, Combined (Plant B). Approximately 1 g samples were weighed out for estrogen extraction.

3.3 Sample Extraction

Wastewater and dried sludge samples were extracted in order to concentrate the estrogen prior to analysis. All equipment used was either new or cleaned via an acid bath, purified water, and high heat. A stock solution for E2 (Sigma, 99% pure Beta-Estradiol) was prepared at 100 mg/L in methanol (Fox Pure Brand, ACS specifications). Spike

standards for sludge extraction were prepared by diluting the stock solution to 1 mg/L with 10% (v/v) methanol in laboratory purified water (17 M Ω ·cm). The spike standard for liquid samples was prepared by diluting the 1 mg/L spike standard to 25 μ g/L in laboratory purified water.

Neither the sludge nor the wastewater samples were subjected to enzymes in order to transform conjugated estrogens to free estrogens. This study focuses only on comparing the free estrogen that is currently available in the sludge and wastewater.

3.3.1 Solid Phase Extraction for Dried Sludge Samples

Sludge samples were extracted using Accelerated Solvent Extraction with a Dionex ASE-200 using a modified extraction and clean-up procedure from Jones-Lepp and Stevens as shown in Figure 3.3 (Jones-Lepp and Stevens, 2007). The extraction method is similar to what other researchers have done, but a different solvent was chosen (Gabet-Giraud, et al., 2010b; Nieto, et al., 2008; Takigami, et al., 2000). The extraction solvent used was 4% (v/v) ammonium hydroxide (Anachemia, ACS specifications) in methanol. Methanol is a common solvent chosen for estrogen extraction because estrogen is very soluble in it and the solvent is easy to evaporate to dryness. The combination of methanol and ammonium hydroxide was chosen because estrogen adsorption capacity is low above pH 11.5. At pH values above the pKa (10.4 for E1 and E2) estrogen has a negative charge (Chen and Hu, 2010). The negative species does not form hydrogen bonds easily with the sludge, therefore making extraction more likely.

Size 22 cells were prepared in layers with filters on both ends (Ahlstrom glass microfiber, 2 cm diameter, grade 131) and components other than the sample were measured by volume with a graduated cylinder. The layers, from bottom to top, consisted

of: 3 mL florisil (EMD Chemicals, 60-100 mesh, gas chromatography grade), 3 mL alumina (EMD Chemicals, 80-200 mesh, chromatographic grade), 2 mL hydromatrix (Varian), a mixture of 10 mL alumina with 5 mL hydromatrix and the 1 g sample, and concluding with 3 mL hydromatrix. For spiked experiments to determine experimental recovery, 100 μ L of the 1 mg/L E2 standard was pipetted on top of the 1 g sample and allowed to soak in for 1 minute before mixing the sample with alumina and hydromatrix and adding it to the cell. For equipment blanks, which served as control tests, the cell was prepared in the same manner except that the sample was omitted.

For the extraction, the operating parameters were set at 80 °C and 2800 psi. The other conditions were: 1 minute preheating time, 5 minutes heating time, 15 minutes static time, 40 mL solvent volume, flush volume 90%, purge time 90 seconds, and 1 static cycle. Before each extraction, solvent lines were rinsed with 3 mL methanol (Fox Pure Brand, ACS specifications). The extract was collected in a 50 mL glass vial with plastic cap and septum.

Following the extraction, extracts were cleaned by rinsing with hexane (Burdick & Jackson, trace analysis grade) and concentrated to 2 mL by drying under nitrogen at 35 °C (Zymark Turbovap II Evaporation Workstation). In the hexane rinse process, about 3 mL of hexane was added to the extract. The container was vortexed and allowed to settle, which formed separate methanol and hexane layers. The hexane was removed by pipette and discarded before continuing with solvent evaporation. After two rinses, there was a visible difference in the extract; the extract was more transparent and less colored. The concentrated 2 mL extracts were transferred to plastic boiling tubes, centrifuged, decanted into glass vials and allowed to evaporate to dryness. The solids remaining in the

boiling tube after decantation were rinsed with methanol and added to the glass vial. The dried extracts were then reconstituted with 10% methanol, transferred to a 10 mL volumetric flask, and diluted in preparation for estrogen analysis. A water bath was utilized to maintain a temperature of 20-23 °C during dilutions.

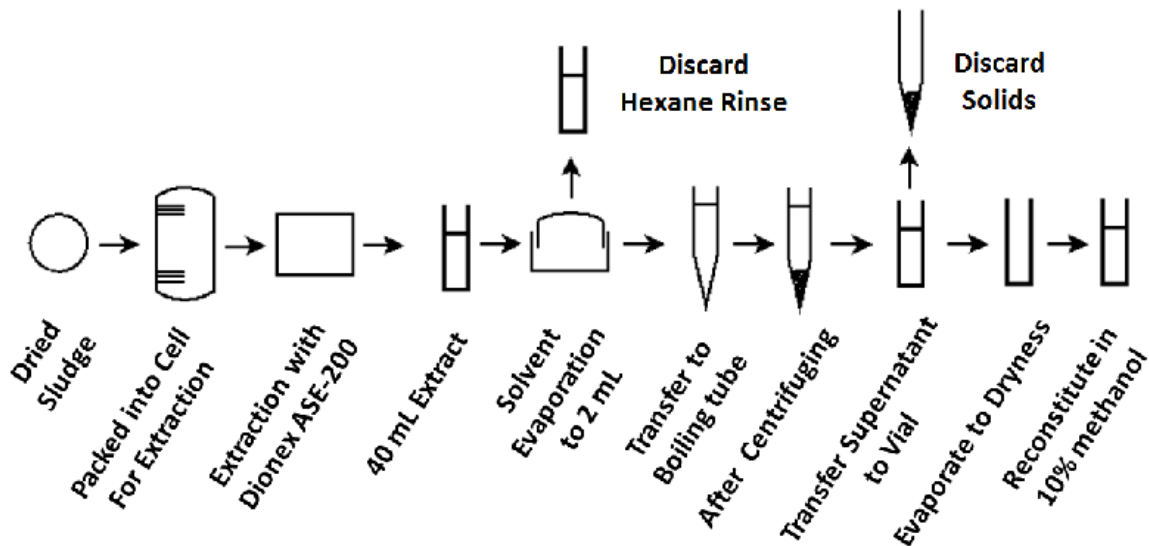

Figure 3.3: Extraction procedure for sludge samples

3.3.2 Solid Phase Extraction for Aqueous Samples

Within three days of collection, aqueous wastewater samples were extracted using an Autotrace Workstation (Caliper Life Sciences) and Oasis HLB 6 mL cartridges based on an established method (Miege, et al., 2009). Aqueous samples were not filtered. Filtering the samples would have removed a portion of the solids (non-settleable) from the analysis since these solids are not included with the dried sludge samples. The Oasis HLB cartridges were pre-conditioned with 6 mL deionized water and 6 mL methanol. The loading was 100 mL for each sample. Samples were percolated at 10 mL/min and

eluted with 4 mL of 70/30 (v/v) mixture of ethyl acetate/methanol. For spiked experiments to determine experimental recovery, the aqueous sample was spiked at 100 ng/L with E2 and mixed well before loading the sample onto the cartridge. For equipment blanks, which served as control tests, laboratory purified water was loaded onto the cartridge.

Following the extraction, extracts were treated similarly to those from the dried sludge samples. Extracts were concentrated to 2 mL by drying under nitrogen at 35 °C (Zymark Turbovap II Evaporation Workstation) and rinsed with hexane (Burdick & Jackson, trace analysis grade). In the hexane rinse process, about 3 mL of hexane was added to the extract. The container was vortexed and allowed to settle, forming a separate layer from the methanol. The hexane was removed by pipette and discarded before continuing with solvent evaporation. One rinse was sufficient to see a decrease in color and an increase in transparency with the extract. The concentrated 2 mL extracts were transferred to plastic boiling tubes, centrifuged, decanted into glass vials and allowed to evaporate to dryness. The solids remaining in the boiling tube after decantation were rinsed gently with methanol and added to the glass vial. The dried extracts were then reconstituted with 10% methanol, transferred to a 10 mL volumetric flask, and diluted in preparation for estrogen analysis. A water bath was utilized to maintain a temperature of 20-23 °C during dilutions.

3.4 Enzyme-linked Immunosorbent Assay (ELISA) Analysis

Estrogen concentrations were measured using an estrogen ELISA kit (Ecologiena, Japan EnviroChemicals, Ltd.). There are relatively few studies where estrogen has been quantified in wastewater (Allinson, et al., 2011; Farre, et al., 2006; Goda, et al., 2000;

Hintemann, et al., 2006; Hirobe, et al., 2006; Li, et al., 2004; Matsui, et al., 2000) and sludge (Suzuki and Maruyama, 2006; Takigami, et al., 2000) using ELISA. None of these studies are from the United States. A combination E1, E2, and E3 ELISA kit was used to determine natural estrogens, expressed as E2. The standard solutions ranged from 0.05 to 3.0 µg/L.

The manufacturer instructions were followed for the analysis procedure. All standards and reagents (antigen-enzyme conjugate powder, buffer solution, concentrated microplate wash solution, coloring reagent, stop solution) were provided by the manufacturer. The kit was stored at 4°C and allowed to reach room temperature before analysis. New antigen-enzyme conjugate powder was reconstituted with the buffer solution for each separate analysis. In a clean microplate, 100 µL of the standard or sample and 100 µL of the conjugate solution were mixed in each well. A 100 µL aliquot of the mixture was transferred to a well of the coated microplate and incubated at room temperature (22 – 25 °C) for 60 minutes. The mixture was removed and the well was gently washed 3 times with 300 µL aliquots. New wash solution was prepared for each test by diluting the concentrated solution provided by the manufacturer. After washing, a 100 µL aliquot of the coloring reagent was added to each well and the microplate was incubated at room temperature (22 – 25 °C) for 30 minutes before adding 100 µL of the stop solution. Absorbance at 450 nm was measured (TECAN 200 microplate reader) within 15 minutes of the reaction stop time.

3.5 Interpolation of Absorbance Data

For each ELISA analysis, a set of 5 standards (0, 0.05, 0.15, 0.50, 3.0 µg/L E2) in duplicate was run to create a calibration curve. A three-parameter exponential equation was used to fit the data to a curve:

$$y = a \cdot e^{(b / (c + x))} \quad (1)$$

a, b, c = fitting parameters

x = concentration

y = absorbance

Using the average (n=4) absorbance values for two scans of the duplicate standards, the fitting parameters were determined for each standard with the Solver tool in Excel®. The average values for the fitting parameters from all 5 standards were used to establish the best-fit curve, as shown in Table 3.2. Figure 3.4 gives a visual representation of the agreement between the best-fit curve and the absorbance values for the 5 standards.

Once the fitting parameters were established, the E2 concentration for samples was determined by interpolation using Equation 1. Absorbance values that fell outside of the range of the standards were not used. Taking into account the 1:10 dilution step just prior to ELISA analysis and the original sample size, the final E2 concentration was determined. Example calculations for a sludge sample and a wastewater sample are given below.

Sludge sample

Initial Dried Sample Mass (Sample Mass): 1.0247 g

E2 Concentration: 1.0772 µg/L or 1077.2 ng/L

Dilution Factor (D_F): 10

Extracted Sample Volume (Vol): 10 mL or 0.01 L

$$\begin{aligned} \text{Final E2 Concentration} &= (\text{E2 Concentration} * D_F * \text{Vol}) / \text{Sample Mass} \\ &= (1077.2 \text{ ng/L} * 10 * 0.01 \text{ L}) / 1.0247 \text{ g} = \mathbf{105.1 \text{ ng/g}} \end{aligned}$$

Wastewater sample

Initial Sample Volume (Sample Volume): 100 mL or 0.1 L

E2 Concentration: 0.10058 µg/L or 100.58 ng/L

Dilution Factor (D_F): 10

Extracted Sample Volume (Vol): 10 mL or 0.01 L

$$\begin{aligned} \text{Final E2 Concentration} &= (\text{E2 Concentration} * D_F * \text{Vol}) / \text{Sample Volume} \\ &= (100.58 \text{ ng/L} * 10 * 0.01 \text{ L}) / 0.1 \text{ L} = \mathbf{100.6 \text{ ng/L}} \end{aligned}$$

Table 3.2: Example of determining fitting parameters for calibration curve

y (Abs)	a	b	c	x (Conc)
1.565851	0.092531	1.171964	0.414320	0 µg/L
1.184900	0.094922	1.172170	0.414343	0.05 µg/L
0.724625	0.091636	1.171407	0.416490	0.15 µg/L
0.336825	0.093570	1.172256	0.415215	0.5 µg/L
0.115824	0.082898	1.158458	0.463616	3.0 µg/L
average	0.091111	1.169251	0.424797	

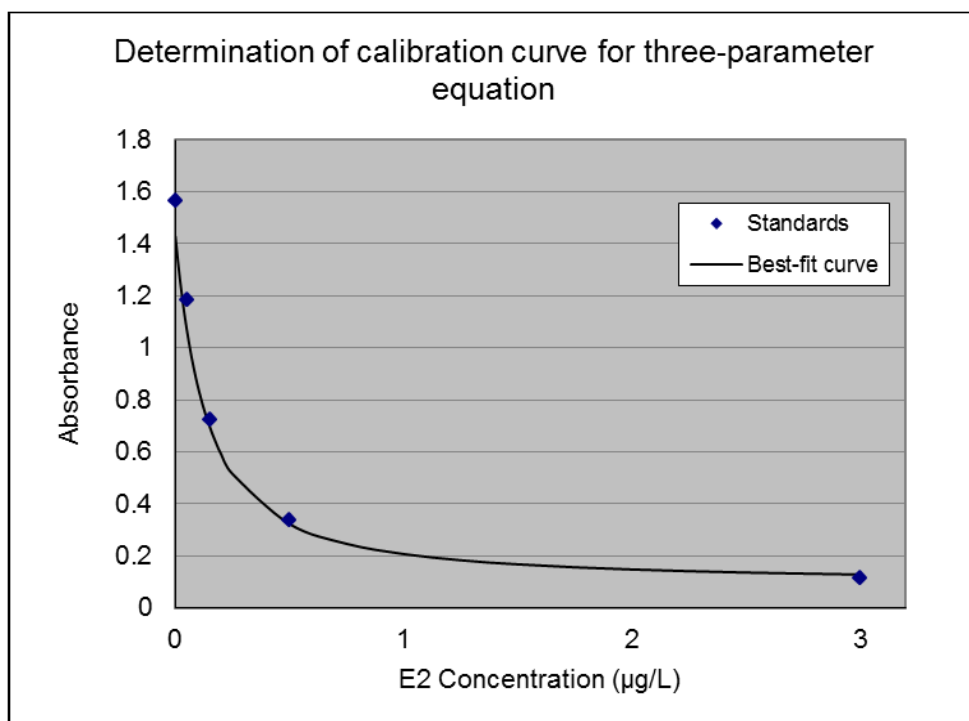

Figure 3.4: Example graph of best-fit line for calibration curve and absorbance values for standards

3.6 Quality Assurance / Quality Control (QA/QC)

Recovery and precision tests were performed for the analytical method to ensure its repeatability and accuracy. They also serve as a way to compare this method to other existing methods and to the reported manufacturer precision of the ELISA kit. Typically, an internal standard is used for analytical work. However, since that is not possible for the ELISA kit, it is important to have some tools in place for judging the validity of the method.

Quality Control for the Extraction Method

Control tests were performed at the start of the process and throughout the experiment to ensure that there was no background level of estrogen detected and that

various procedures did not remove or add estrogen. Equipment blanks, a field blank, a laboratory blank, solvent checks, and various method checks were performed. Equipment blanks involved extractions that did not contain samples, as described in sections 3.3.1 and 3.3.2. Table 3.3 shows the results from equipment blanks. The calculated concentration was determined from the measured absorbance using Equation 1. All but one test resulted in values below the detection limit of 0.05 µg/L. The equipment blank on 6/13/2011 that was a significant concentration can be attributed to a leak in the Dionex ASE-200. Samples from this date were excluded in the final results and all extractions after this date were performed using a different ASE-200 with the same method as before.

Table 3.3: Results for equipment blanks

Sludge Extraction – Dionex ASE-200					
Extraction Date	Calculated Concentration (µg/L)	Reported value (µg/L)	Extraction Date	Calculated Concentration (µg/L)	Reported value (µg/L)
6/23/2011	0.0102	< 0.05	5/3/2011	0.0195	< 0.05
6/13/2011*	0.6210	0.62	4/7/2011**	-0.0692	< 0.05
6/2/2011	0.0427	< 0.05	4/7/2011**	-0.0112	< 0.05
5/16/2011	0.0164	< 0.05	3/16/2011	0.0008	< 0.05
5/16/2011	0.0180	< 0.05	3/16/2011**	-0.0020	< 0.05
5/3/2011	0.0194	< 0.05	3/16/2011	0.0008	< 0.05
Liquid Extraction – Caliper Autotrace					
6/1/2011	0.0060	< 0.05			
* Leak detected while operating ASE-200 on this day; contamination from previous samples is likely					
** Negative value is a product of absorbance data interpolation and best-fit equation; absorbance values were a close match to 0 µg/L E2 standard					

For the field blank, collected on 3/3/2011, one HDPE container of laboratory purified water was poured into another HDPE container while at a sampling location. The field blank received the same treatment for transportation and storage as the other samples. The laboratory blank contained laboratory purified water that had the same storage conditions as the samples, but the container was not transported to the field location. Analysis for the field and laboratory blanks consisted of direct testing via ELISA and the concentrations were below detection limits ($< 0.05 \mu\text{g/L}$). No extractions were performed with the field or laboratory blanks. Solvent checks involved direct testing via ELISA of the 10% methanol solution used in preparing the standards and diluting the extracts. On each occasion ($n=3$), the concentration was below detection limits.

Control tests were performed for several steps of the method. The HDPE sampling containers and Oasis HLB cartridges were tested indirectly through the field and laboratory blanks. The plastic boiling tubes and glass vials were tested by using methanol in the subsequent procedure: centrifuging, decanting into glass vials, allowing the solvent to evaporate, reconstituting with 10% methanol, and analyzing via ELISA. The concentration was below detection limits, indicating the containers did not have an adverse effect on the method. Several hexane rinses were tested to ensure that no estrogen was partitioning to this phase during the clean-up step of the extract. The hexane rinses were treated in the same manner as the extracts and all tests resulted in concentrations below detection limits.

Two steps of the method did show detectable estrogen loss, which impacted the final procedure. During the initial extractions (3/3/2011), the solids remaining in the boiling tube after decantation were ignored. To check if estrogen remained in the boiling

tubes, the solids were rinsed with methanol, poured into a separate glass vial than the extract, and treated in the same way as the extract. The estrogen concentration was 0.17 $\mu\text{g/L}$, which is greater than the detection limit. In all subsequent extractions, the solids were rinsed with methanol and added to the decanted extract, as described in sections 3.3.1 and 3.3.2. This procedural change was introduced to limit the loss of estrogen. One other step of the method that showed estrogen loss during initial extractions was not altered because it would have doubled the time needed for extractions. Dewatered sludge that was spiked with estrogen was compared through single extractions (static cycle = 1) and double extractions (static cycle = 2) to determine if some of the estrogen remained with the sludge after the first extraction. The results are shown in Table 3.4. Overall, the single extractions for the 5 sludge samples were very similar (CV = 3.67%). The second extraction retrieved additional estrogen, corresponding to around 14% of the combined extracts. It is clear that a single extraction will not result in total desorption of estrogen from the sludge and extraction cell components (alumina, florisol, and hydromatrix). Although treating each sample to a double extraction would give more accurate results for total estrogen in each sludge sample, this study does not require the higher accuracy. It was deemed more efficient to complete single extractions for all sludge types and therefore be able to make direct comparisons within this study.

Quality Control for Spike Standards

Based on the product information from the manufacturer, β -estradiol solutions should be prepared fresh, rather than storing them for future use. To check if the spike standards degraded over time, they were diluted to 1 $\mu\text{g/L}$ and tested in duplicate several times throughout the experimental timeframe. As shown in Table 3.5, the solutions were

stable for about one month, but the solutions did show degradation. Spike standards were prepared in March, early May and late May. The spike standard prepared on 3/3/2011 was used for extractions between 3/3/2011 and 4/13/2011. The spike standard prepared on 5/3/2011 was used for extractions on 5/3/2011 and 5/16/2011. The spike standard prepared on 5/31/2011 was used for extractions between 6/1/2011 and 6/23/2011. The early May spike standard differed by 8% from the beginning to the end of the month, which shows there is a little deterioration. However, it is not necessary to prepare the standard daily or weekly, as indicated in other studies (Baronti, et al., 2000).

The desired concentration for the spike standards was 100 µg/L. As shown in Table 3.5, that exact concentration was difficult to achieve. Ideally, the data for all the spiked experiments should be adjusted for the actual concentration of the spike standard. These data are used to calculate the recovery for the extractions. Since only an approximate recovery was needed, it was deemed unnecessary to adjust the data for the actual concentration of the spike standard.

Table 3.4: Comparison of single and double extractions for dewatered sludge

Sludge sample	Extraction 1 (µg/L)	Extraction 2 (µg/L)	Total E2 (µg/L)	% of E2 in extraction 2
1	17.11	2.78	19.89	14.0%
2	18.93	< 3.0	< 21.93	< 13.7%
3	17.87	n/a	17.87	n/a
4	17.76	n/a	17.76	n/a
5	18.11	n/a	18.11	n/a

Table 3.5: Concentration of estrogen spike standards over time

Spike Standard	Tested on 5/24/2011	Tested on 6/7/2011	Tested on 6/21/2011
1 (prepared 5/3/2011)	112 µg/L	101 µg/L	93.6 µg/L
	114 µg/L	106 µg/L	89.3 µg/L
2 (prepared 5/31/2011)	n/a	86.7 µg/L	87.8 µg/L
	n/a	89.7 µg/L	91.1 µg/L

Precision Experiments for ELISA Analysis

ELISA precision was tested throughout the experiment. Analytical duplicates for selected extractions were performed and the coefficient of variation (CV) was calculated (Table 3.6). Precision was also judged by analytical duplicates for E2 standards (Table 3.7).

The manufacturer reports that the CV is usually below 10% and a comparison study between ELISA and LC-MS/MS also reported less than 10% CV (Farre, et al., 2006). The duplicate standard tests are in agreement with this value; however, a few of the samples had poorer precision. This could be due to non-homogeneous samples, malfunctioning pipettes or human error. In general, ELISA analysis proved to be repeatable.

Table 3.6: Coefficients of variation for ELISA analytical duplicates

Sludge Samples							
Sample	E2 Conc. (µg/L)	E2 Conc. (µg/L)	CV (%)	Sample	E2 Conc. (µg/L)	E2 Conc. (µg/L)	CV (%)
PC1	51.7	53.9	2.9%	CT2	53.0	53.4	0.6%
PC2	42.7	35.3	13.4%	PC3	43.2	42.1	1.8%
TF	52.4	52.5	0.2%	AB2	31.0	31.7	1.6%
AB1	24.0	20.8	10.3%	DAFT	20.9	24.6	11.7%
CT1	43.9	40.9	5.0%	Combined	24.9	24.8	0.28%
AD	62.6	59.4	3.7%	CT3	40.0	42.9	4.9%
Wastewater Samples							
Sample	E2 Conc. (µg/L)	E2 Conc. (µg/L)	CV (%)	Sample	E2 Conc. (µg/L)	E2 Conc. (µg/L)	CV (%)
GT1	310.2	323.4	2.9%	CT2	744.2	790.3	4.2%
TF	354.6	349.4	1.0%	PC3	316.3	331.7	3.4%
AB1	23.2	17.4	20.2%	Combined	328.5	324.2	0.9%
AD	561.2	601.6	4.9%	CT3	275.0	251.8	6.2%

Table 3.7: ELISA analytical duplicates for estrogen standards

04/13/11				06/07/11			
Standard	E2 Calc. Conc. (µg/L)	E2 Calc. Conc. (µg/L)	CV (%)	Standard	E2 Calc. Conc. (µg/L)	E2 Calc. Conc. (µg/L)	CV (%)
0	1.5536	1.5865	1.48%	0	1.0546	1.0930	2.5%
0.05	1.1910	1.1737	1.03%	0.05	0.8811	0.8771	0.3%
0.15	0.7456	0.7009	4.37%	0.15	0.5666	0.5876	2.6%
0.50	0.3415	0.3321	1.97%	0.50	0.2721	0.2638	2.2%
3.0	0.1204	0.1111	5.68%	3.0	0.1114	0.1045	4.5%

Recovery Experiments for the Extraction Method

Overall recovery was used to judge the complete method. It was not used to correct the final measurement since not all sample types were spiked and there were variations in recovery. For the sludge samples, overall recovery was tested by spiking the 1 g dried sample with 100 ng E2 (Sigma, 99% pure Beta-Estradiol) just before mixing with the alumina and hydromatrix or by spiking the alumina directly for the blank sample. For the liquid wastewater samples, overall recovery was tested by spiking purified water or wastewater samples prior to extraction. Recovery was calculated as expressed in Equations 2 and 3:

Spiked alumina (sludge blank) and laboratory purified water

$$\text{Recovery} = \frac{\text{estrogen measured}}{\text{spiked estrogen amount}} \times 100 \quad (2)$$

Spiked sludge and wastewater samples

$$\text{Recovery} = \frac{\text{estrogen measured} - \text{measured sample load}}{\text{spiked estrogen amount}} \times 100 \quad (3)$$

Spiked samples were always extracted and analyzed concurrently with unaltered samples in order to determine the sample load. Recovery was variable (Table 3.8), but this is typical of other studies with estrogens with recovery reported from 70-125% (Farre, et al., 2006; Hintemann, et al., 2006; Miege, et al., 2009; Takigami, et al., 2000). Low recovery values could be due to irreversible adsorption of the estrogen to the sludge or extraction materials (i.e., alumina, hydromatrix, HLB cartridge), as well as loss during other steps of the method. Recovery values above 100% could be due to poor precision

between the spiked and unspiked ELISA analyses or a more complete extraction for the spiked sample as compared to the unspiked sample.

Recovery for various steps of the method was determined in order to see if significant losses occurred in any individual step of the method (Table 3.9). The steps tested were: solvent concentration with nitrogen, centrifuging, and reconstitution. A known amount (100 ng) was used in each step and each was performed in duplicate or triplicate. Loss due to sample transfer was not quantified directly; however, it is indirectly included for the tested steps. Recovery was calculated using Equation 2. As seen in Table 3.9, there was estrogen loss throughout the method; however, the CV reveals that the loss is consistent and therefore all samples are expected to have the same loss and can be directly compared.

Table 3.8: Recovery of estrogen for spiked samples

Sludge Samples					
Sample	Recovery Range	Sample	Recovery Range	Sample	Recovery Range
BNR	52-77%	PC3	108-124%	Combined	91-99%
CT2	74-76%	AB2	60-62%	CT3	49-51%
Wastewater Samples					
Sample	Recovery Range	Sample	Recovery Range	Sample	Recovery Range
DAFT	76-81%	Plant A Influent	126-139%	Plant A Effluent	48-75%
CT2	105%				
Blank Samples					
Sludge Extraction	59-60%	Wastewater Extraction	78-85%		

Table 3.9: Recovery of estrogen for selected steps of the method

Step	Expected E2 (ng)	Test 1 (ng)	Test 2 (ng)	Test 3 (ng)	Average Recovery	CV (%)
Solvent Concentration	100	66.9	68.7	N/A	68%	1.9%
Centrifuging	100	86.3	79.2	75.1	80%	7.1%
Reconstitution	100	72.1	74.7	66.4	71%	6.0%

CHAPTER 4

EFFECT OF SECONDARY TREATMENT TYPE ON ESTROGEN REMOVAL IN WASTEWATER TREATMENT PLANTS

4.1 Introduction

Estrogen is known to be biodegraded partially during wastewater treatment (Andersen, et al., 2005; Joss, et al., 2004; Ternes, et al., 1999a). The process involved is likely aerobic co-metabolism. Anaerobic biodegradation also occurs, but the process is much slower. In a batch-test biodegradation study, estradiol (E2) removal was 88% within one day for aerobic conditions while anaerobic conditions resulted in only 50% degradation after seven days (Lee and Liu, 2002). Initially, it was suspected that ammonia oxidizing bacteria, such as *Nitrosomonas europaea*, in nitrifying activated sludge were responsible for estrogen biodegradation during wastewater treatment (Shi, et al., 2004a; Vader, et al., 2000). More recently, it appears that heterotrophic bacteria are responsible (Gaulke, et al., 2008; Ren, et al., 2007b). A proposed metabolic pathway suggests the conversion of E2 to E1, followed by oxidation and ring cleavage; however, the process is still not completely understood (Lee and Liu, 2002).

Previous research has demonstrated that activated sludge treatment will result in greater biodegradation of estrogen as compared to trickling filters (Janex-Habibi, et al., 2009; Svenson, et al., 2003; Ternes, et al., 1999a). Although batch-test experiments show biodegradation for anoxic and anaerobic conditions, these compartments within full-scale treatment plants do not show significant estrogen removal (Joss, et al., 2004). Taking this

into account, an activated sludge system with biological nutrient removal (BNR) may be expected to result in the same biodegradation as a non-BNR activated sludge system. Other factors that may also play a role in estrogen removal are the solids retention time (SRT) and the concentration of mixed liquor suspended solids (MLSS). A greater SRT has been shown to result in increased estrogen biodegradation (Andersen, et al., 2003; Joss, et al., 2004). Higher MLSS presents the opportunity for more adsorption, which could lead to higher estrogen removal through biodegradation occurring on the solids or through simple elimination from the aqueous phase (i.e. effluent) by sorption to the sludge (Khanal, et al., 2006).

In this study, estrogen concentration in sludge and wastewater streams was compared for three secondary treatment types at two wastewater treatment plants: trickling filter (Plant A), non-BNR activated sludge (Plant A), BNR (Plant A) and BNR (Plant B). Although estrogen removal in wastewater treatment plants has been reported previously (Andersen, et al., 2003; Baronti, et al., 2000; Braga, et al., 2005a; Braga, et al., 2005b; Clara, et al., 2004; Esperanza, et al., 2007; Gabet-Giraud, et al., 2010a; Janex-Habibi, et al., 2009; Johnson, et al., 2005; Joss, et al., 2004; Muller, et al., 2008; Svenson, et al., 2003; Ternes, et al., 1999b; Ying, et al., 2008), the uniqueness of this study is that the different treatment units receive wastewater from the same community. This situation allows for a direct comparison between treatment types since all three processes have the same wastewater source and essentially the same pre-treatment (bar screen, grit chamber, and primary clarifier). For each treatment process, estrogen removal was determined for both the aqueous phase and the solid phase of the sludge.

4.2 Materials and Methods

A detailed description is provided in chapter 3, along with diagrams (Figure 3.1 and Figure 3.2) showing sampling locations at Plant A and Plant B. Briefly, grab samples from two wastewater treatment plants were collected in 500 mL HDPE bottles on two occasions in spring and early summer. At the lab, the samples were centrifuged to separate the liquid and solid phases of the sludge. The liquid portion was stored in the refrigerator (4 °C) and the solid portion in the freezer (-5 to -10 °C). The frozen samples were dried in an oven (90-100 °C) and ground with a mortar and pestle or pulverized with a high-speed mixer mill.

Approximately 1 g of dried sludge was extracted (Dionex ASE-200) with 4% (v/v) ammonium hydroxide. The unfiltered liquid phase (100 mL) underwent solid phase extraction (Caliper Life Sciences Autotrace Workstation) with Oasis HLB 6 mL cartridges. The samples were eluted with 4 mL of 70/30 (v/v) mixture of ethyl acetate / methanol. Both the extracts from the dried sludge and the liquid phase were concentrated to 2 mL by drying under nitrogen (Zymark Turbovap II Evaporation Workstation) in a water bath (35 °C). The extracts were allowed to evaporate to dryness at room temperature and reconstituted with 10% (v/v) methanol in laboratory purified water (17 M Ω ·cm).

Estrogen concentrations were measured using an estrogen enzyme-linked immunosorbent assay (ELISA) kit. Typically, estrogens in wastewater and sludge have been measured using liquid chromatography coupled with mass spectrometry (LC-MS) (Farre, et al., 2006; Gabet-Giraud, et al., 2010b; Gomes, et al., 2004; Nieto, et al., 2008; Snyder, et al., 2003a; Vanderford, et al., 2003; Yang, et al., 2010) or gas chromatography

with mass spectrometry detection (GC-MS) (Hanselman, et al., 2006; Ternes, et al., 2002). There are at least 9 reports available in the literature on the use of ELISA for estrogen quantification in wastewater and sludge with the majority coming from China and Japan (Allinson, et al., 2011; Farre, et al., 2006; Goda, et al., 2000; Hintemann, et al., 2006; Hirobe, et al., 2006; Li, et al., 2004; Matsui, et al., 2000; Shi, et al., 2010; Suzuki and Maruyama, 2006; Takigami, et al., 2000). There are no prior reports for estrogen analysis by ELISA from studies in the United States. ELISA analysis presents several advantages over LC-MS and GC-MS, including: 1) no need for expensive instrumentation or highly experienced technicians, 2) no derivatization for samples, 3) less sample pre-treatment and purification, 4) rapid and simultaneous analysis of many samples, and 5) consistent results with typically less than 10% CV (Farre, et al., 2006; Li, et al., 2004). Disadvantages include overestimation due to cross-reactions and low ability to measure conjugated estrogens; however, improved ELISA design has reduced cross-reactions (mainly below 0.7%) (Farre, et al., 2006) and estrogen glucuronides are deconjugated rapidly during secondary treatment (Gomes, et al., 2009) making conjugated estrogen analysis unnecessary after primary treatment.

A combination E1, E2, and E3 ELISA kit (Ecologiena, Japan EnviroChemicals, Ltd.) was used to determine natural estrogens, expressed in estradiol equivalent (EEQ) concentration as E2. The standard solutions ranged from 0.05 to 3.0 µg/L. Conjugated estrogens were not intentionally quantified. All standards and reagents were provided by the manufacturer and the manufacturer's instructions were followed for the analysis procedure. Absorbance at 450 nm was measured (TECAN 200 microplate reader) within 15 minutes of the reaction stop time. A calibration curve was determined by fitting data

from 5 standards to a three-parameter exponential equation. The estrogen concentration for samples was determined by interpolation using this equation. Final estrogen concentrations were calculated by taking into account dilutions and the original sample size. Total estrogen as E2 was reported in dried sludge samples as ng/g and in the aqueous phase as ng/L. Blank, recovery and replicate tests were included in the experimental matrix.

4.3 Results and Discussion

4.3.1 Estrogen Analysis with ELISA

Precision

As part of the method development process, replicate tests were performed. Replicate tests for extractions and analytical duplicates were completed during the two sampling campaigns. High precision was obtained for analytical duplicates of selected samples, as shown in Table 4.1. Most of the CV % values obtained are significantly lower than the manufacturer specifications of 10%. Replicate extraction samples consisted of dried sludge or wastewater from the same collection container that was treated in the same way and extracted in parallel. In two situations (solid phase of the trickling filter and aqueous phase of BNR), replicate extraction samples are not available due to equipment malfunction. As seen in Table 4.2, extraction replicates showed variability. This could be due to estrogen loss during the method or non-homogeneous samples. In the case of the solid phase BNR sample for Plant A, the measurements are so far apart that they have little value. Ideally, this sample would have been extracted again, but it could not be done due to time constraints with the equipment.

Recovery

Single recovery tests were performed on extractions for selected samples. These tests were limited due to time constraints with the equipment, as well as cost. A recovery range is given based on analytical duplicates. Recovery was variable (Table 4.3), but this is typical of other estrogen studies using SPE where recovery ranged from 62-125% (Farre, et al., 2006; Hintemann, et al., 2006; Miege, et al., 2009; Suzuki and Maruyama, 2006; Takigami, et al., 2000). One study had very a similar recovery (62%) for spiked sludge (Suzuki and Maruyama, 2006) and another study demonstrated an average recovery of 70% for spiked sludge (Takigami, et al., 2000). Low recovery values could be due to irreversible adsorption of the estrogen spike to the sludge or extraction materials (i.e., alumina, hydromatrix, HLB cartridge), as well as loss during other steps of the method.

Recovery experiments with the solid phase of sludge are more challenging than with the aqueous phase, as pointed out by Gomes, et al., (2004) and Ternes, et al (2002). Spiking on top of the dried sludge and allowing a short time for adsorption is not the same as what occurs during wastewater treatment. The amount recovered should be considered as the maximum extractable quantity (Ternes, et al., 2002). Also, there needs to be a balance between removing interfering compounds and losing the target compound through clean-up steps (Gomes, et al., 2004).

Since recovery varied and was not performed for all matrices, the final reported concentrations were not adjusted. A preferable approach would be to use an internal standard, one that is not present in the matrix already, and measure the recovery of that compound from the beginning of the method to the end. Then the reported values would

be adjusted based on the internal standard recovery. This tactic is not possible for the analytical method employed in this study because the ELISA kit only measures estrogens. This is a disadvantage of ELISA analysis. However, the benefit of quicker analysis and the minimal instrumentation required outweigh that disadvantage (Farre, et al., 2006; Suzuki and Maruyama, 2006).

Table 4.1: Analytical duplicates

Sample	E1+E2+E3 Conc.	E1+E2+E3 Conc.	CV (%)
Solid phase, Trickling Filter	52.4 ng/g	52.5 ng/g	0.2%
Solid phase, BNR (Plant B)	31.0 ng/g	31.7 ng/g	1.6%
Solid phase, non-BNR	24.0 ng/g	20.8 ng/g	10.3%
Aqueous phase, Trickling Filter	354.6 ng/L	349.4 ng/L	1.0%

Table 4.2: Replicate extraction samples

Sample	E1+E2+E3 Conc.	E1+E2+E3 Conc.	CV (%)
Solid phase, BNR (Plant B)	23.7 ng/g	28.6 ng/g	13.2%
Solid phase, BNR (Plant A)	116.5 ng/g	19.6 ng/g	101%
Solid phase, non-BNR	22.4 ng/g	21.2 ng/g	5.4%
Aqueous phase, Trickling Filter	352.0 ng/L	290.5 ng/L	13.5%
Aqueous phase, non-BNR	20.6 ng/L	20.3 ng/L	1.0%
Aqueous phase, BNR (Plant B)	28.8 ng/L	28.5 ng/L	0.7%

Table 4.3: Recovery experiments for extractions

Solid Phase			
Sample	Recovery Range	Sample	Recovery Range
BNR (Plant A)	52-77%	BNR (Plant B)	60-62%
Blank Samples			
Sludge Extraction	59-60%	Wastewater Extraction	78-85%

4.3.2 Effect of Secondary Treatment Type on Estrogen Removal

Results from the two sampling campaigns were combined. This study did not look at temporal variations, but the temperature difference between campaigns was not drastic. The temperature of the wastewater was for campaign 1 was 21.0 °C and campaign 2 was 24.8 °C. As with most studies involving sludge, grab samples were collected since it is difficult to collect hydraulically-linked or 24 hour composite sludge samples. The samples were collected at different times for the campaigns; however, this is likely not a concern. A study on estrogen showed that there was low (<20% RSD) inter-day variability at 14 French WWTPs (Gabet-Giraud, et al., 2010b).

Estrogen concentrations in the solid and aqueous phases are given in ng/g and ng/L, respectively. For the solid phase, the term “load” is used instead of concentration in order to distinguish the two phases more readily. In the context of this research, load refers to the mass of estrogen (ng) in the sample per dried mass (g) of the entire solid sample.

Trickling Filter

Samples for the trickling filter were obtained from the return stream of the sedimentation basin at Plant A (Figure 3.1). The estrogen load in the sludge for the

primary clarifier (40.0 ± 1.4 ng/g as E2) preceding the trickling filter and the estrogen concentration in the aqueous phase of the primary influent (429 ± 2.1 ng/L as E2) were measured in order to evaluate the change in estrogen concentration caused by this treatment step.

In general, information is scarce on the estrogen load for sludge and no other reports were found with a load for trickling filter solids (Table 4.4). Other studies have looked at estrogen removal in the aqueous phase after trickling filters (Janex-Habibi, et al., 2009; Johnson, et al., 2007; Ternes, et al., 1999a; Ternes, et al., 1999b) or estrogen load in the final dewatered sludge for treatment trains that included a trickling filter (Janex-Habibi, et al., 2009). Although E2 removal was high for some WWTPs in the Janex-Habibi et al. study (Table 4.4), good E2 removal was associated with high E1 in the trickling filter effluent. Taking this into account, the combined estrogen (E1 + E2) would be higher and consequently total estrogen removal would be much lower (data not presented in paper). Since these removals do not take total estrogen into account, they should not be compared directly against the other reported removals.

Estrogen removal in the aqueous phase for the trickling filter is low compared to other studies (Table 4.4). However, the removal is close to the low end of the Johnson et al. (2007) study when the standard deviations are taken into account. Overall, this study suggests that estrogen removal for the trickling filter was incomplete and low compared to activated sludge (Table 4.6), which was expected. As for the solid phase, no comparison is possible with other studies. The load is slightly higher on the trickling filter solids compared to primary sludge. Without more measurements, it is not possible

to confirm that estrogen load for the trickling filter solids is generally higher compared to primary sludge.

Table 4.4: Comparison of estrogen load and removal for trickling filters

Reference	Solid Phase		Aqueous Phase	
	Conc. E1+E2+E3 (ng/g dw as E2)	Removal	Conc. E1+E2+E3 (ng/L as E2)	Removal
This study	52.5	-31%	321±43	25±13%
Ternes et al. 1999a	n.d.	n.d.	n.r.	67%
Johnson et al. 2007	n.d.	n.d.	n.r.	70±36% (E2 only)
Janex-Habibi et al. 2009	n.d.	n.d.	n.r.	*79% (E2 only)
Janex-Habibi et al. 2009	n.d.	n.d.	n.r.	*0% (E2 only)
Janex-Habibi et al. 2009	n.d.	n.d.	n.r.	*10% (E2 only)
Janex-Habibi et al. 2009	n.d.	n.d.	n.r.	*83% (E2 only)

n.r. = not reported; n.d. = not determined; dw = dry weight; * estimated from figure, exact value not reported

Biological Nutrient Removal

Samples were collected from the BNR return activated sludge (RAS) streams at both Plant A and Plant B. This study is focused on the end result for each secondary treatment and therefore intermediate samples were not collected. There may be variability in estrogen adsorption to the sludge and aqueous phase concentration in the anoxic and aerobic zones, but that was not evaluated. The estrogen concentration in the aqueous phase and estrogen load in the solid phase for the primary clarifier preceding BNR was

measured in order to evaluate the change caused by this treatment step (Plant A: 43.9 ± 12.7 ng/g and 400 ± 8.0 ng/L; Plant B: 39.5 ± 4.5 ng/g and 324 ng/L; estrogen as E2 for solid and aqueous phases, respectively). The values are close between the two plants, which is expected because the wastewaters being treated in both plants are from the same city and have similar characteristics.

BNR differs from conventional activated sludge treatment in that there are anaerobic or anoxic zones in addition to an aerobic zone. These different environments promote the growth of different microorganisms and also impact whether phosphate is stored or utilized. A few studies have quantified estrogen in the aqueous and solid phases for BNR treatment (Table 4.5). Aqueous phase removal is greater than 70% and frequently above 90%. In the Janex-Habibi et al. study (2009), the removals reported are for E2 only and not total estrogen. Aerobic conditions are ideal for the conversion of E2 into E1, so the total estrogen removal may be lower.

The roughly 90% aqueous phase removals in the BNR of this study agree with previously reported results (Table 4.5). It was expected that BNR would have high removal because it includes an aerobic phase. Janex-Habibi et al. reports a significant reduction in E2 for the solid phase, which was not seen in this study. However, the removals reported by Janex-Habibi et al. do not account for E1 that is present from E2 transformation. The high variability for estrogen load on the Plant A BNR sludge makes interpretation for those results very difficult. The estrogen load for the Plant B BNR sludge is higher than those reported previously (Table 4.5), but still lower than the estrogen load measured in the primary sludge (39.5 ± 4.5 ng/g as E2) and dewatered sludge (41.2 ± 6.4 ng/g as E2) at that plant. Overall, the estrogen concentrations in the

Plant B BNR aqueous and solid phases coincide with expectations based on results from other reports in the literature.

Table 4.5: Comparison of estrogen load and removal for BNR

Reference	Solid Phase		Aqueous Phase	
	Conc. E1+E2+E3 (ng/g dw as E2)	Removal	Conc. E1+E2+E3 (ng/L as E2)	Removal
This study, Plant A	63.8±49.0	-45±82%	46.9	89%
This study, Plant B	27.9±3.9	29±18%	28.7±0.2	91±0.7%
Janex-Habibi et al., 2009	n.r.	*88-96% (E2 only)	n.r.	*70-97% (E2 only)
Janex-Habibi et al., 2009	n.r.	*86-88% (E2 only)	n.r.	*90-95% (E2 only)
Janex-Habibi et al., 2009	n.r.	*95% (E2 only)	n.r.	*97% (E2 only)
Janex-Habibi et al., 2009	n.r.	*70% (E2 only)	n.r.	*77% (E2 only)
Andersen et al., 2003	~8.2 (E1+E2)	n.d.	<2	>99% (E1+E2)
Muller et al., 2010	13±6.4 (E1+E2)	n.r.	n.r.	n.r.
Joss et al., 2004	n.r.	n.r.	34.6±6 (E1+E2)	n.r.
Joss et al., 2004	n.r.	n.r.	47±8.2 (E1+E2)	n.r.
Ternes et al., 2002	5 (E1+E2)	n.r.	n.r.	n.r.

n.r. = not reported; n.d. = not determined; dw = dry weight; * estimated from figure, exact value not reported; ~ = estimated value (not measured)

Non-BNR Activated Sludge

Samples were collected from the nitrification basin RAS stream at Plant A. The Trickling Filter preceded this treatment step and estrogen levels were measured in the aqueous and solid phases, as reported earlier.

Several researchers have examined the fate of estrogens in the aqueous phase for conventional activated sludge (Andersen, et al., 2003; Baronti, et al., 2000; Braga, et al., 2005b; Carballa, et al., 2004; D'Ascenzo, et al., 2003; Gabet-Giraud, et al., 2010a; Gomes, et al., 2009; Hashimoto, et al., 2007; Holbrook, et al., 2002; Janex-Habibi, et al., 2009; Johnson, et al., 2005; Joss, et al., 2004; Muller, et al., 2008; Nieto, et al., 2008; Ternes, et al., 1999b; Ying, et al., 2008) but only a handful have quantified estrogen on the sludge itself (Andersen, et al., 2003; Braga, et al., 2005b; Joss, et al., 2004; Koh, et al., 2009; Muller, et al., 2008; Nieto, et al., 2008; Ternes, et al., 2002).

Estrogen load for activated sludge in this study falls into the middle of the range for previously reported values (Table 4.6). Janex-Habibi et al. (2009) reports a significant decrease in estrogen load on activated sludge, but these values only represent E2 and not total estrogen. The aqueous phase in this study is slightly higher than what is reported elsewhere; however, the initial concentration entering the nitrification basin (trickling filter effluent, 321 ng/L) is also higher compared to the other studies (70-85 ng/L). All of the activated sludge treatments consistently remove at or above 90% of the estrogen in the aqueous phase.

Table 4.6: Comparison of estrogen load and removal for non-BNR activated sludge

Reference	Solid Phase		Aqueous Phase	
	Conc. E1+E2+E3 (ng/g dw as E2)	Removal	Conc. E1+E2+E3 (ng/L as E2)	Removal
This study	31.5±17	40±17%	20.5±0.2	94±14%
Ternes et al., 2002	54 (E1+E2)	n.r.	n.r.	n.r.
Andersen et al., 2003	4.2-9.9 (E1+E2)	n.r.	1.8 (E1+E2)	98%
Braga et al., 2005	16.5±9.4 (E1+E2)	n.r.	9.1±4.2 (E1+E2)	85-96%
Muller et al., 2010	55±13 (E1+E2)	n.r.	n.r.	n.r.
Lorenzen et al., 2004	11.3 (E2)	n.r.	n.r.	n.r.
Gabet-Giraud et al., 2010	n.r.	n.r.	n.r.	>89%
Janex-Habibi et al., 2009	n.r.	*79-97% (E2 only)	n.r.	*97-98% (E2 only)
Janex-Habibi et al., 2009	n.r.	*91% (E2 only)	n.r.	*95% (E2 only)
Janex-Habibi et al., 2009	n.r.	*90% (E2 only)	n.r.	*91% (E2 only)
Janex-Habibi et al., 2009	n.r.	*88% (E2 only)	n.r.	*95% (E2 only)

n.r. = not reported; n.d. = not determined; dw = dry weight; * estimated from figure, exact value not reported

4.3.3 Comparison of Secondary Treatment Units

Three secondary treatment types (trickling filter, non-BNR activated sludge, and BNR) were compared on the basis of estrogen load to sludge and estrogen removal in the aqueous phase of wastewater. Although two WWTPs were involved, the source wastewater came from the same city and estrogen concentration was similar after primary treatment.

Decrease in estrogen load on sludge between treatment units

There is a small reduction in estrogen load between the primary and BNR sludges at Plant B ($29\pm 18\%$) and between the trickling filter and non-BNR sludges at Plant A ($40\pm 17\%$). The reduction could be an artifact of the extraction process if the estrogen is not uniformly desorbed from different sludge matrices. Unfortunately, this is an inherent problem when dealing with wastewater sludge and not even isotopic dilution can overcome this obstacle (Ternes, et al., 2002).

Another possibility is that the reduction is due to different adsorption capacities of the sludges, but other research indicates this is not the case. Although primary and secondary sludges have very different composition, adsorption appears to be similar and rapid. Using activated sludge that was inactivated with heat, in order to eliminate biodegradation as a factor, Ren et al. (2007) demonstrated that estrogen has an initial rapid adsorption ($105\text{-}237 \mu\text{g/g}$ in 10 minutes), followed by slow and continuous adsorption that leads to $>93\%$ removal from the aqueous phase. Some researchers have reported Freundlich adsorption coefficients (K_F) for estrogen onto activated sludge (Chen and Hu, 2010; Clara, et al., 2004; Ren, et al., 2007b), while others have reported solid-water distribution coefficients (K_d) for estrogen on activated sludge (278-476 L/kg) (Andersen, et al., 2005; Joss, et al., 2004; Ternes, et al., 2004) and digested sludge (303-461 L/kg) (Carballa, et al., 2008). Only one study has reported on adsorption for primary sludge (Ternes, et al., 2004). This study examined EE2 and not E2; however, EE2 adsorption was similar for primary (278 L/kg) and secondary sludge (349 L/kg) and the EE2 K_d coefficients are within the same order of magnitude as E2. The similarity in

values for K_d among various sludges (i.e., primary, secondary, and digested) suggests that estrogen adsorption is not significantly affected by sludge type.

Biodegradation is the most likely cause for the decrease in estrogen load. Desorption into the aqueous phase is a possibility, but it is a much slower process than biodegradation. In bench-scale experiments with activated sludge, E1 and E2 desorption were <1.1% within three hours (Ren, et al., 2007b) while biodegradation was essentially complete within one hour (Hashimoto and Murakami, 2009). The bench-scale tests by Hashimoto and Murakami monitored aqueous and solid phase estrogen levels. Results showed that most of the E2 (94-98%) in the aqueous phase was biodegraded or transformed to E1 within 5 minutes and the aqueous E1 was subsequently biodegraded within one hour. For the solid phase, estrogen load increased in the 5 minutes after the initial spike and gradually decreased within one hour. Some information is available on the pathway for biodegradation (Lee and Liu, 2002), but there is still no information on where biodegradation occurs, such as: on the floc surface, throughout the floc or in the medium around the floc through release of extracellular enzymes (Joss, et al., 2004). In general, after fast adsorption to sludge, biodegradation will reduce estrogen in both the aqueous and solid phases. Applying the trend to this study, biodegradation explains the reduction in estrogen load on the sludge which occurred concurrently with a significant estrogen drop in the aqueous phase between primary and BNR sludges at Plant B ($91\pm 0.7\%$) and between the trickling filter and non-BNR sludges at Plant A ($94\pm 14\%$).

Comparison of aqueous phase estrogen removal

As expected, estrogen removal in the aqueous phase was greater for the BNR activated sludge treatments ($91\pm 0.7\%$ and 89%) than the trickling filter ($25\pm 13\%$).

Further evidence of the enhanced estrogen removal capability of activated sludge treatment is shown by the low aqueous estrogen concentration (20.5 ± 0.2 ng/L as E2) for the nitrification basin immediately following the trickling filter in Plant A. The nitrification basin removed $94 \pm 14\%$ of estrogen in the aqueous phase, bringing the concentration very close to the secondary effluent at Plant B. Also, the estrogen load on the sludge (31.5 ± 17 ng/g as E2) is similar to the activated sludge at Plant B (27.9 ± 3.9 ng/g as E2).

Previously, it was thought that ammonia oxidizing bacteria (AOB) were responsible for estrogen biodegradation based on bench-scale studies (Shi, et al., 2004b; Vader, et al., 2000). These bacteria are more plentiful in sludge operated at a high SRT and some studies saw positive correlation between estrogen removal and SRT (Andersen, et al., 2003; Joss, et al., 2004). In particular, Andersen et al. (2003) measured estrogen concentration in the effluent of a conventional AS (SRT <4 days) WWTP prior to its conversion to BNR (SRT 11-13 days). After conversion, E1 and E2 were below the detection limit (1 ng/L) and previous measurements were 5 ng/L E2 and 24 ng/L E1.

Recent work demonstrates that heterotrophic bacteria are more important than nitrifying bacteria for estrogen biodegradation in full-scale WWTPs (Gaulke, et al., 2008; Ren, et al., 2007a; Suzuki and Maruyama, 2006). Work by Suzuki and Maruyama (2006) suggests that estrogen biodegradation with activated sludge is independent of nitrification. Ren et al. (2007a) found that E3 is mainly biodegraded by heterotrophic bacteria and some of the same researchers noticed that when AOB are inhibited, there is still biodegradation by heterotrophic bacteria (Ren, et al., 2007b).

In light of this new information, as well as the studies that show full-scale anaerobic and anoxic zones have little impact on estrogen biodegradation (Joss, et al., 2004), it makes sense that non-BNR and BNR activated sludges result in the same estrogen removal, as shown in this study.

Comparison of estrogen load on sludge for secondary units

Estrogen load on the sludge was higher for trickling filter solids (52.5 ng/g as E2) than non-BNR activated sludge (31.5±17 ng/g as E2) and BNR sludge (27.9±3.9 ng/g as E2). There are a few possibilities that can explain the higher loading for the trickling filter solids. First, some studies have shown that biodegradation is lower for trickling filters as compared to a highly aerobic process such as activated sludge treatment (Janex-Habibi, et al., 2009; Svenson, et al., 2003; Ternes, et al., 1999b). Lower biodegradation would mean a higher amount of estrogen remains adsorbed to the sludge. Activated sludge has been shown to have a very high capacity to adsorb estrogen and studies were unable to reach saturation (Clara, et al., 2004; Ren, et al., 2007b). While no adsorption studies have been completed with trickling filter solids, adsorption capacity is likely high as well based on similarities in adsorption among sludges, which was covered earlier in the discussion.

Second, trickling filter solids may be exposed to more estrogen than other sludges. In theory, the SRT for a TF is infinite. However, biofilm does slough off and leave. An equivalent SRT can be calculated based on BOD loading to the TF (Metcalf & Eddy, 2003). Average BOD in the primary effluent at Plant A is 120 mg/L and the volume of one tank is 5044 m³. Based on this loading (0.9 kg BOD/m³·d), the equivalent SRT is about 2.5 days. Compared to the SRTs (5-8 days) for the activated sludge units, this is

significantly shorter. However, the aqueous phase estrogen concentration remains high throughout the TF treatment, unlike the activated sludge process where biodegradation is rapid. The combination of high estrogen concentration and high adsorption capacity could result in greater estrogen exposure for the TF solids, even with a low SRT. More research is necessary to confirm this assertion. Adsorption studies have not been performed for trickling filter solids.

CHAPTER 5

EFFECT OF SLUDGE HANDLING PROCESSES ON ESTROGEN CONCENTRATION IN WASTEWATER SLUDGES

5.1 Introduction

Endocrine-disrupting compounds (EDCs), such as estrogen, are known to be present in the aquatic environment at concentrations that affect fish and other wildlife (Jobling, et al., 1998; Routledge, et al., 1998). It has been established that wastewater treatment plants are major contributors of estrogen to the environment (Daughton and Ternes, 1999). As pointed out in review papers (Combalbert and Hernandez-Raquet, 2010; Khanal, et al., 2006), most of the previous research on estrogen has focused on the effluent or aqueous phase of wastewater. Estrogen fate for sludge has received far less attention, despite estrogen's relatively high octanol-water partition coefficients (K_{ow}), which signal a preference for adsorption to solids over remaining in the aqueous phase (Gomes, et al., 2004; Khanal, et al., 2006). In fact, adsorption to sludge is greater for estrogen compared to other micropollutants (Uruse and Kikuta, 2005). Previous research has shown that 6-43% of the total estrogen entering the wastewater treatment plant is adsorbed onto the solid phase (Andersen, et al., 2003; Braga, et al., 2005b; Combalbert and Hernandez-Raquet, 2010; Janex-Habibi, et al., 2009; Suzuki and Maruyama, 2006). In light of an increasing trend for land application of sludge, as opposed to landfilling, it

will become even more important to monitor estrogens in wastewater sludge, as they pose a risk of groundwater and surface water contamination.

A handful of studies have looked at estrogen concentration on activated sludge (Andersen, et al., 2003; Baronti, et al., 2000; Clara, et al., 2004; Joss, et al., 2004; Suzuki and Maruyama, 2006; Ternes, et al., 1999a), but only a few have examined the fate of estrogen for particular sludge treatment processes (Andersen, et al., 2003; Braga, et al., 2005b; Esperanza, et al., 2007; Janex-Habibi, et al., 2009; Lorenzen, et al., 2004; Muller, et al., 2008). A downside to these studies is that the treatment processes were compared among different WWTPs with different wastewater sources and therefore a direct comparison is difficult.

The goal of this study was to determine estrogen load (mass estrogen per mass solids) for sludge after particular sludge treatment processes, such as thickening, dewatering, and digestion. Specifically, the following treatment processes were examined: gravity thickener, dissolved air flotation thickening, centrifuging, and anaerobic digestion. This study involves WWTPs where the wastewater source is from the same city, which should make direct comparison easier. For each sludge treatment process, both the estrogen load on the sludge and the estrogen concentration in the aqueous phase were determined before and after treatment. Mass balance calculations were performed for each sludge treatment process to check for estrogen loss through biodegradation or partition change between the solid and aqueous phases. A sensitivity analysis was performed to determine which parameters in the mass balance analysis exhibited the greatest influence.

5.2 Materials and Methods

A detailed description is provided in chapter 3, along with diagrams (Figure 3.1 and Figure 3.2) showing sampling locations at Plant A and Plant B. Briefly, grab samples from two wastewater treatment plants were collected in 500 mL HDPE bottles on two occasions in spring and early summer. At the lab, the samples were centrifuged to separate the aqueous and solid phases of the sludge. The aqueous portion was decanted and stored in the refrigerator (4 °C), while the solid portion was placed in the freezer (-5 to -10 °C). The frozen samples were dried in an oven (90-100 °C) and ground with a mortar and pestle or pulverized with a high-speed mixer mill. The aqueous phase was not filtered prior to analysis. Filtering the sample would have removed non-settleable solids that were still present in the aqueous phase after centrifuging and decanting.

Approximately 1 g of dried sludge was extracted (Dionex ASE-200) with 4% (v/v) ammonium hydroxide. The aqueous phase (100 mL) underwent solid phase extraction (Caliper Life Sciences Autotrace Workstation) with Oasis HLB 6 mL cartridges. The samples were eluted with 4 mL of 70/30 (v/v) mixture of ethyl acetate / methanol. Both the extracts from the dried sludge and the aqueous phase were concentrated to 2 mL by drying under nitrogen (Zymark Turbovap II Evaporation Workstation) in a water bath (35 °C). The extracts were allowed to evaporate to dryness at room temperature and reconstituted with 10% (v/v) methanol in laboratory purified water (17 MΩ·cm).

Estrogen concentrations were measured using an estrogen enzyme-linked immunosorbent assay (ELISA) kit (Ecologiena, Japan EnviroChemicals, Ltd.). A combination E1, E2, and E3 ELISA kit was used to determine natural estrogens, expressed as E2. The standard solutions ranged from 0.05 to 3.0 µg/L. Conjugated

estrogens were not quantified. All standards and reagents were provided by the manufacturer and the manufacturer instructions were followed for the analysis procedure. Absorbance at 450 nm was measured (TECAN 200 microplate reader) within 15 minutes of the reaction stop time. A calibration curve was determined by fitting data from 5 standards to a three-parameter exponential equation. The estrogen concentration for samples was determined by interpolation using this equation. Final estrogen concentrations were calculated by taking into account dilutions and the original sample size. Total estrogen as E2 was reported in dried sludge samples as ng/g_{ss} and in the aqueous phase as ng/L_{aq}. Blank, recovery and replicate tests were included in the experimental matrix.

5.3 Results and Discussion

5.3.1 Estrogen Analysis with ELISA

Precision

As part of the method development process, replicate tests were performed. Replicate tests for extractions and analytical duplicates were completed during the two sampling campaigns. High precision (0.6-13.4%) was obtained for analytical duplicates of selected extractions, as shown in Table 5.1. Most of the CV % values obtained are significantly lower than the manufacturer specifications of 10%. Replicate extraction samples consisted of dried sludge or wastewater from the same collection container that was treated in the same way and extracted in parallel. As seen in Table 5.2, extraction replicates showed greater variability (0.5-30.8%); however, only 4 sample locations (PC 2, GT 1, CT 2, and Combined) exceeded 15% over the two collection campaigns. All of

these were extractions for dried sludge, which is known to be complex and difficult to extract (Ternes, et al., 2002).

Recovery

Single recovery tests were performed on extractions for selected samples. These tests were limited due to time constraints with the equipment, as well as cost. A recovery range is given based on replicate ELISA analysis. Recovery was variable (Table 5.3), but this is typical of other estrogen studies using SPE where recovery ranged from 62-125% (Farre, et al., 2006; Hintemann, et al., 2006; Miege, et al., 2009; Suzuki and Maruyama, 2006; Takigami, et al., 2000). As discussed in chapter 4, there is no way to prove complete extraction of estrogen from sludge, even with an internal standard. Since recovery varied and was not performed for all matrices, the final concentrations reported were not adjusted.

Table 5.1: Precision for ELISA replicates

ELISA precision							
Plant A				Plant B			
Sample	E1+E2+E3 Conc.	E1+E2+E3 Conc.	CV (%)	Sample	E1+E2+E3 Conc.	E1+E2+E3 Conc.	CV (%)
Solid phase, primary sludge (PC 1)	42.7 ng/g	35.3 ng/g	13.4	Solid phase, primary sludge (PC 3)	43.2 ng/g	42.1 ng/g	1.8
Solid phase, primary sludge (PC 2)	51.7 ng/g	53.9 ng/g	2.9	Solid phase, dissolved air flotation thickening (DAFT)	30.9 ng/g	24.6 ng/g	11.7
Solid phase, digested sludge (AD)	62.6 ng/g	59.4 ng/g	3.7	Solid phase, dewatered sludge (CT 3)	40.0 ng/g	42.9 ng/g	4.9
Solid phase, dewatered sludge (CT 2)	53 ng/g	53.4 ng/g	0.6	Aqueous phase, influent	263.8 ng/L	284.6 ng/L	5.4
Aqueous phase, influent	397.7 ng/L	464.1 ng/L	10.9	Aqueous phase, primary sludge (PC 2)	316.3 ng/L	331.7 ng/L	3.4
Aqueous phase, effluent	82.3 ng/L	89.8 ng/L	6.2	Aqueous phase, primary and secondary sludge (combined)	328.5 ng/L	324.2 ng/L	0.9
Aqueous phase, primary sludge (PC 1)	310.2 ng/L	323.4 ng/L	2.9	Aqueous phase, dewatering centrate (CT 3)	275 ng/L	251.8 ng/L	6.2
Aqueous phase, digested sludge (AD)	561.2 ng/L	601.6 ng/L	4.9				
Aqueous phase, dewatering centrate (CT 2)	744.2 ng/L	790.3 ng/L	4.2				

Table 5.2: Precision for extraction replicates

Extraction precision							
Sample	Plant A			Sample	Plant B		
	E1+E2+E3 Conc. Range	E1+E2+E3 Conc. Avg.	CV (%)		E1+E2+E3 Conc. Range	E1+E2+E3 Conc. Avg.	CV (%)
Solid phase, primary sludge (PC 1)	39.0-41.0 ng/g	40.0 ng/g	3.6	Solid phase, primary sludge (PC 3)	36.3-42.7 ng/g	39.5 ng/g	11.4
Solid phase, primary sludge (PC 2)	34.9-52.8 ng/g	43.9 ng/g	28.9	Solid phase, dissolved air flotation thickening (DAFT)	22.6-25.4 ng/g	23.6 ng/g	6.7
Solid phase, thickened primary sludge (GT 1)	38.6-73.5 ng/g	56.9 ng/g	30.8	Solid phase, primary and secondary sludge (combined)	18.3-31.9 ng/g	25.0 ng/g	27.1
Solid phase, thickened primary sludge (GT 2)	37.9-39.9 ng/g	38.7 ng/g	2.7	Solid phase, dewatered sludge (CT 3)	34.7-47.4 ng/g	41.2 ng/g	15.4
Solid phase, digested sludge (AD)	61.0-70.7 ng/g	67.3 ng/g	8.1	Aqueous phase, influent	274.2-287.8 ng/L	281.0 ng/L	3.4
Solid phase, dewatered sludge (CT 2)	53.2-79.3 ng/g	66.2 ng/g	27.9	Aqueous phase, effluent	13.7-14.1 ng/L	13.9ng/L	2.0
Aqueous phase, influent	428.0-430.9 ng/L	429.4 ng/L	0.5	Solid phase, dissolved air flotation thickening (DAFT)	15.5-19.0 ng/L	17.2 ng/L	14.2
Aqueous phase, effluent	86.1-87.8 ng/L	86.9 ng/L	1.4				
Aqueous phase, primary sludge (PC 1)	259.4-316.8 ng/L	288.1 ng/L	14.1				
Aqueous phase, primary sludge (PC 2)	34.3-405.6 ng/L	400.0 ng/L	2.0				
Aqueous phase, dewatering centrate (CT 2)	767.3-907.8	837.5	11.9				

Table 5.3: Recovery experiments for extractions

Solid Phase			
Sample	Recovery Range	Sample	Recovery Range
CT 2	74-76%	PC 3	108-124%
Combined	91-99%	CT 3	49-51%
Aqueous Phase			
Influent, Plant A	48-75%	Effluent, Plant A	126-139%
DAFT	76-81%		
Blank Samples			
Sludge Extraction	59-60%	Wastewater Extraction	78-85%

5.3.2 Change in Estrogen Concentration Due to Sludge Handling Processes

Gravity Thickeners

Gravity thickeners are used to concentrate suspended solids through sedimentation in order to reduce the volume of sludge that receives further treatment. In the WWTPs studied, gravity thickeners are used to concentrate primary sludge. Samples were collected for two gravity thickeners (GT 1 and GT 2) at Plant A. While there is some difference between the results, the estrogen load in the thickened primary sludge is similar given the analytical error for these measurements.

As expected, there is minimal change in the estrogen load for the sludge before and after thickening (Figure 5.1). In the thickeners, there is little opportunity for biodegradation because the conditions are anaerobic. Biodegradation rates have been shown to be slower in anaerobic and anoxic (>4 hours) compared to aerobic (<1 hour) environments (Hashimoto and Murakami, 2009; Lee and Liu, 2002). The return stream

from GT 1 shows a similar estrogen concentration as the influent, which fits the expectation that estrogen biodegradation is negligible during primary treatment.

The return stream from GT 2 shows a lower estrogen concentration compared to the influent. Removal could be due to some degree of biodegradation or adsorption to solids. Neither of these alternatives is expected to be significant since biodegradation is slow in anaerobic conditions and estrogen adsorption is fast (Ren, et al., 2007b), thus it would have occurred before primary sedimentation. Analytical error and variability between grab samples are more likely explanations for the low estrogen concentration in the GT 2 return stream.

One study was found in which the estrogen load on sludge was measured before and after thickening (Esperanza, et al., 2007); however, only the load for primary sludge (before thickening) is reported in the paper. Consequently, the results from this study cannot be compared to previous work. Several studies state that primary treatment provides no estrogen removal (Braga, et al., 2005a; Holbrook, et al., 2002; Muller, et al., 2008; Ternes, et al., 1999b), but these studies did not investigate primary sludge treatment, such as gravity thickeners.

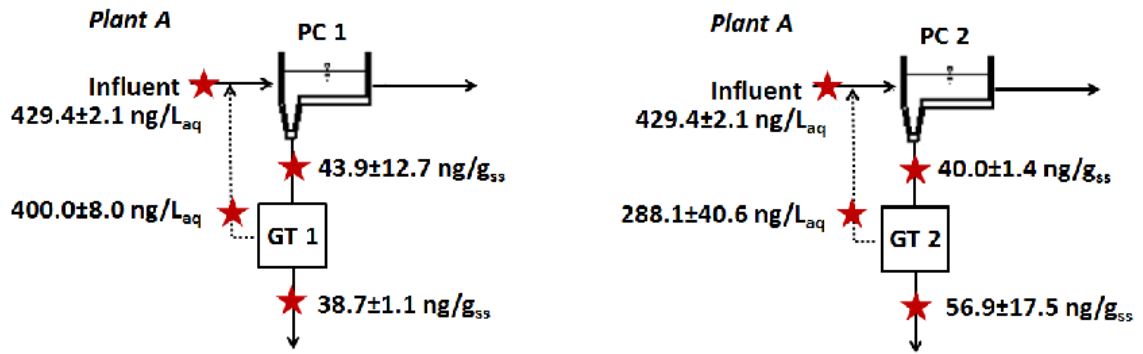

Figure 5.1: Estrogen concentration before and after gravity thickeners

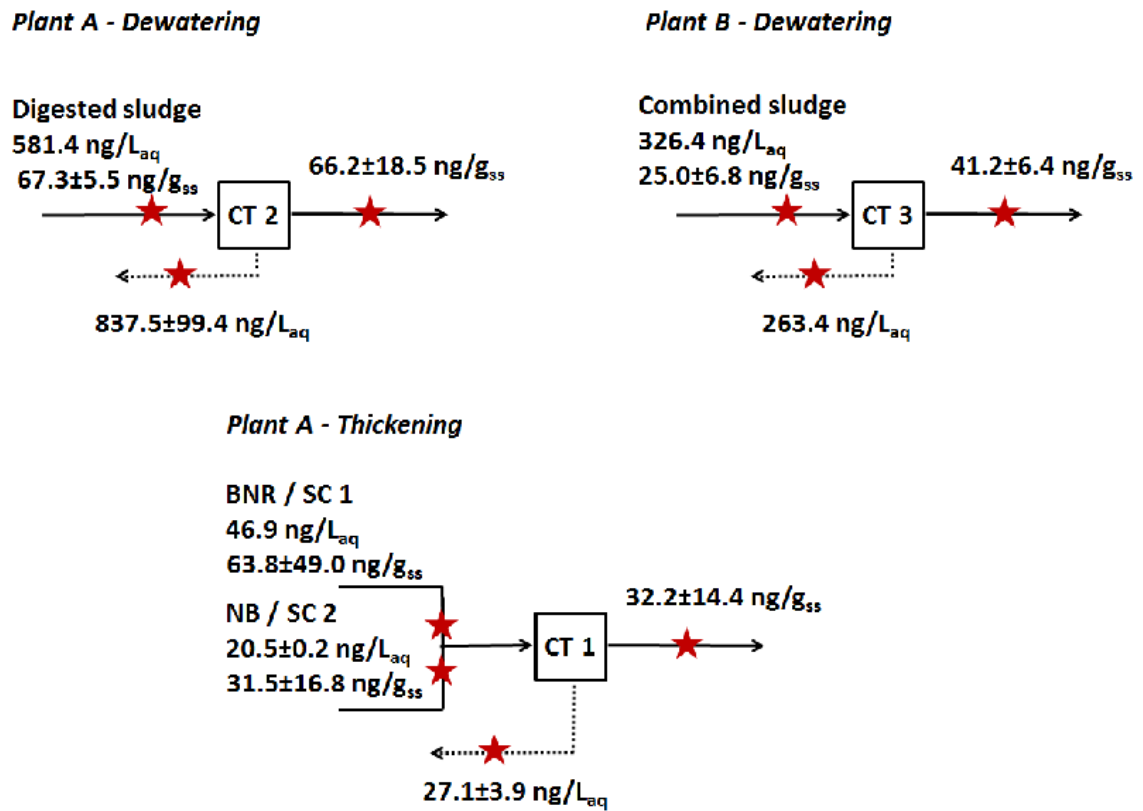

Figure 5.2: Estrogen concentration before and after centrifuging

Centrifuges

Centrifuges are used to thicken or dewater sludge, depending on the solids concentration in the feed. Thickened sludge refers to material that is fluid and can be pumped in a pipeline. Dewatered sludge refers to material that has less water, so it is no longer fluid and cannot be pumped. In this study, samples were collected for two dewatering centrifuges and one thickening centrifuge.

The thickening centrifuge (CT 1) was fed by two secondary sludges at Plant A (Figure 5.2). The feed had low estrogen concentration in both the aqueous and solid phases, which is typical of aerobically treated wastewater because biodegradation is very effective under aerobic conditions (Hashimoto and Murakami, 2009; Lee and Liu, 2002). The centrate and thickened secondary sludge had estrogen concentrations that were in the same range as the feed. This suggests that centrifuging had no effect on estrogen concentration. This is expected because the process is not aerated, so biodegradation is unlikely, and the spinning motion of the centrifuge seems not to impact adsorption on stabilized sludge.

The two dewatering centrifuges had different feeds (digested sludge vs. thickened sludge) and different results. CT 2, which had digested sludge as the feed, shows an increase in estrogen concentration in the aqueous phase (44%) and essentially no change (<2%) in estrogen load for the sludge. CT 3, which has thickened sludge as the feed, shows a decrease in estrogen concentration in the aqueous phase (19%) and an increase (65%) in estrogen load on the sludge. Although the increase in estrogen load for the sludge after CT 3 seems high, when the standard deviations are taken into account, the values are quite similar. It appears that there is an increase in total estrogen after CT 2;

however, a mass balance of the system provides a better viewpoint for identifying changes between the aqueous and solid phases.

Dissolved Air Flotation Thickening (DAFT)

DAFT is a process where solids are separated from the wastewater by buoyancy. Fine air bubbles are used to lift solids to the surface and then the solids are removed with a skimmer. DAFT was used at Plant B to thicken activated sludge in the waste stream after the secondary clarifier. Estrogen concentration in the feed was low and decreased noticeably in the aqueous phase (40%) and slightly in the solid phase (15%). Estrogen removal by biodegradation is a strong possibility because DAFT is an aerated process. No other studies were found on estrogen removal via DAFT. In general, micropollutant removal by DAFT is seldom reported (Reungoat, et al., 2010).

Anaerobic Digestion

Anaerobic digestion is a microbial degradation process in the absence of molecular oxygen. It is used in order to decrease sludge volume and to stabilize it by reducing volatile solids. Anaerobic digestion converts organic matter into methane, carbon dioxide and water. Plant A uses a mesophilic anaerobic digester.

Compared to the feed sludges, the estrogen load on the digested sludge was significantly higher (51%). The estrogen concentration in the aqueous phase (supernatant) was higher than the influent for the WWTP. Given that solids were destroyed and the solids concentration changed, it is unwise to evaluate the results for anaerobic digestion without looking at a mass balance. However, it is clear that biodegradation did not occur during anaerobic digestion, which is expected based on bench-scale experiments (Hashimoto and Murakami, 2009).

Several studies have examined estrogen fate during anaerobic digestion conditions (Andersen, et al., 2003; Carballa, et al., 2006; des Mes, et al., 2008; Esperanza, et al., 2007; Holbrook, et al., 2002; Janex-Habibi, et al., 2009; Joss, et al., 2004; Lorenzen, et al., 2004; Muller, et al., 2010). Joss et al. (2004) performed batch tests under anaerobic conditions. The results suggest that digester supernatant will have a high estrogen concentration due to deconjugation of estrogen from primary sludge and estrogen desorption from digested sludge. An increase in estrogen after digestion was confirmed. Lorenzen et al. (2004) measured significantly higher estrogen in sludge after anaerobic (1233 ng/g) treatment compared to aerobic treatment (11.2 ng/g) for 19 WWTPs in Canada. Andersen et al. (2003) found an increased estrogen concentration in the anaerobic digester effluent (5.4 ng/L E2, 67.1 ng/L E1) compared to the aqueous phase for activated sludge (1.4 ng/L E1). The authors state that estrogen input and output are equal for the anaerobic digester in their study, but this is based on an assumption since primary sludge was not analyzed for estrogen. Holbrook et al. (2002) measured estrogenic activity with the YES assay before and after anaerobic and aerobic digestion of sludge. Estrogenic activity increased drastically in the aqueous and solid phases following digestion. The authors suggest an increase in extractability for the digested sludge. Muller et al. (2010) and Janex-Habibi et al. (2009) found a slight increase in E1 load on sludge after anaerobic digestion.

Other studies have shown estrogen removal or no impact on estrogen concentration during anaerobic digestion. Esperanza et al. (2007) conducted parallel pilot-scale experiments with anaerobic and aerobic digestion. Both digesters showed estrogen removal (aerobic: 69% E1, 90% E2; anaerobic: 68% E1 and E2); however, the authors

express caution in these values because a significant fraction of estrogen in the synthetic influent remained unaccounted for after analysis. The supernatant of the anaerobically digested sludge had greater estrogen concentration and the authors suggest that this is due to the higher solids destruction for anaerobic digestion (45.5%) compared to aerobic digestion (36.1%). Pilot-scale experiments by Carballa et al. (2007) demonstrated 88% removal for estrogen by anaerobic digestion. Des Mes et al. (2008) studied anaerobic digestion for pig manure and found no biodegradation for estrogen, but about 30% of the available estrogen adsorbed to the sludge.

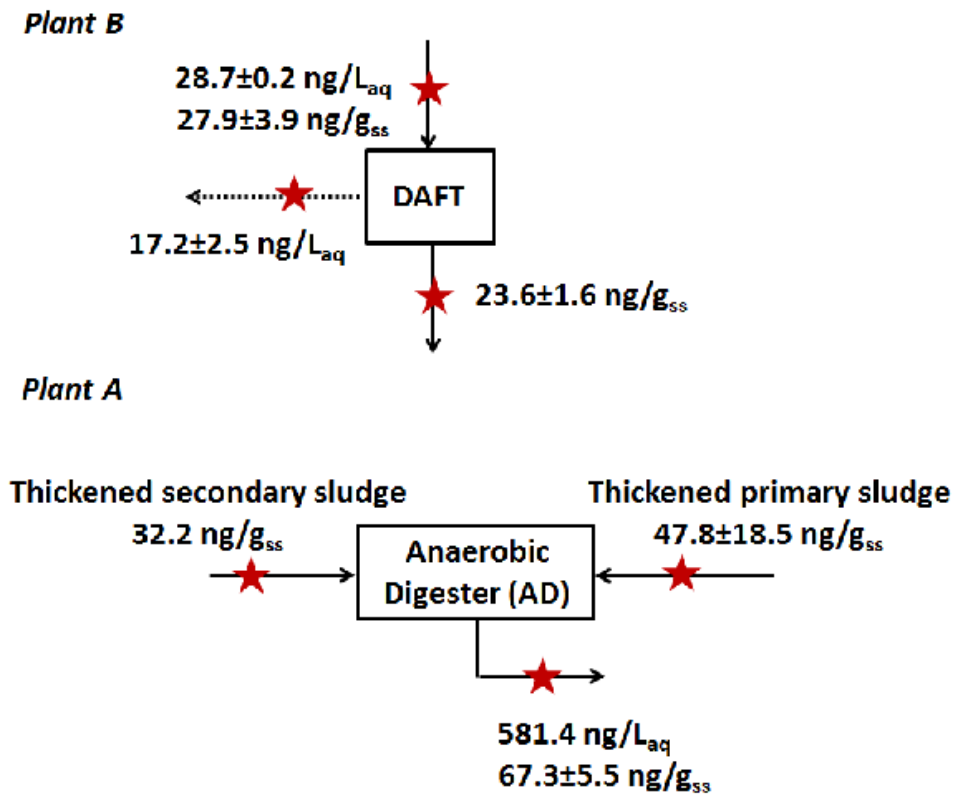

Figure 5.3: Estrogen concentration before and after DAFT and anaerobic digestion

5.3.3 Mass Balance of Estrogen in Sludge Handling Processes

Calculation of Mass Balance

For each of the sludge handling processes considered in this research, mass balance calculations were completed to compare E2 load for the sludge, wastewater and return streams before and after treatment. One treatment process, centrifuge thickening (CT 1), was not included in mass balance calculations because the ratio of secondary sludges entering the centrifuge was not known. Wherever possible, average values for E2 concentration were used. Total suspended solids concentrations were estimated based on previously measured values at each WWTP (Jeong, 2004; Mota, 2001). Detailed calculations are found in Appendix A.

Mass balance for anaerobic digestion required knowing the ratio of sludges entering the digester. The feed for the anaerobic digester in this study was 80% thickened primary sludge and 20% thickened secondary sludge by volume; primary and secondary sludge both contained 76% volatile solids. It was assumed that 60% of the volatile solids in the primary sludge and 20% of the volatile solids in the secondary sludge were destroyed (Metcalf & Eddy, 2003; Grady et al., 1999). Biodegradation was ignored as part of the calculations. If biodegradation did occur, it would be apparent by a decrease between the input and output concentrations.

Mass Balance Sensitivity

Due to the uncertainty in data for the mass balance calculations, a sensitivity analysis was completed to identify which parameters exhibited the greatest influence. The sensitivity analysis was performed for Plant B, Dewatering Centrifuge (CT 3). The comparison value chosen was the net E2 formed. The following 7 parameters were varied

one at a time by $\pm 1\%$, $\pm 5\%$, and $\pm 10\%$: combined primary and secondary sludge E2 concentration, combined primary and secondary aqueous phase E2 concentration, dewatered sludge E2 concentration, centrate E2 concentration, solids concentration for combined sludge, solids concentration for dewatered sludge, and solids concentration for centrate.

The new values for net E2 formed were graphed and a trendline for each parameter was created. A steeper slope corresponds to greater sensitivity for the parameter. The highest sensitivity was found for dewatered sludge E2 concentration (square) and solids concentration for dewatered sludge (triangle) as shown in Figure 5.4. Sensitivity is a direct reflection of E2 contribution. In this example, dewatered sludge ($1595 \text{ ng/L}_{\text{ww}}$) contributes far more E2 to the total output ($1819 \text{ ng/L}_{\text{ww}}$) than the centrate ($224 \text{ ng/L}_{\text{ww}}$). Consequently, both factors associated with dewatered sludge (E2 concentration and solids concentration) have the greatest influence. For improved mass balance accuracy, these parameters should be measured multiple times for precision.

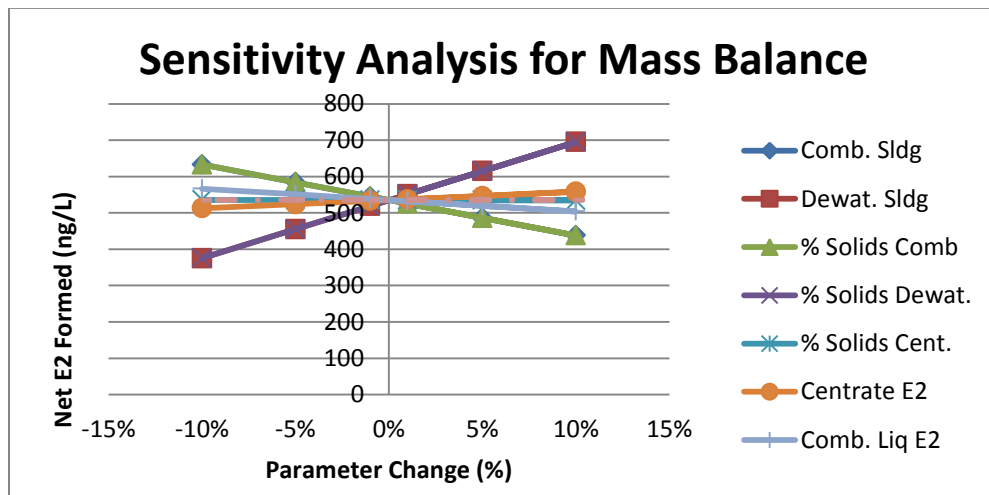

Figure 5.4: Sensitivity Analysis for Mass Balance Calculations

5.3.4 Fate of Estrogen in Sludge Handling Processes

Gravity Thickeners

This treatment process does not significantly impact estrogen concentration. Although the output shows a small decrease compared to the input, it is in the same range as the analytical variability for the measurements (Table 5.4). No other data have been found regarding the mass balance of a gravity thickener.

Dissolved Air Flotation Thickening

A decrease in the output (Table 5.4) suggests some degree of biodegradation may have occurred. This study has only a few measurements at one location. Further research is needed to confirm this assertion and verify that it holds true at other WWTPs. Even when estrogen is removed to below detection limits in the aqueous phase, the solid phase usually maintains a small estrogen load as shown in bench-scale experiments (Hashimoto and Murakami, 2009) and full-scale samples (Andersen, et al., 2003). DAFT could be a beneficial treatment option for further reducing estrogen in sludge.

Centrifuges

Results for the two dewatering centrifuges are contradictory. The centrifuge receiving digested sludge showed little change (8.7%) between the total input and output. This agrees with another study where centrifuge dewatering did not impact estrogen concentration (Muller, et al., 2008). Mechanical dewatering by a filter press also had little impact on estrogen concentration (Braga, et al., 2005b).

In this study, the centrifuge receiving thickened sludge showed a significant increase (41%), which could be due to analytical error, estrogen deconjugation, or a change in estrogen extractability from the sludge. Estrogen deconjugation is unlikely

because most glucuronides are deconjugated to free estrogens during activated sludge treatment and the sulfates that are not transformed in secondary treatment remain conjugated in the effluent (Gomes, et al., 2009). Muller et al. (2010) suggested that thermal-pressurized treatment increased estrogen extractability prior to centrifuge dewatering in their study. In the work presented here, there was no treatment beyond thickening prior to centrifuge dewatering; therefore, analytical error is the most reasonable answer. The estrogen load on the sludge represented the largest contribution (1595 ng/L_{ww}) to the total estrogen output (1819 ng/L_{ww}). As shown in the sensitivity analysis, a higher contribution means a greater influence, so the mass balance could be skewed by the measurement for estrogen load on the dewatered sludge.

Anaerobic Digestion

Mass balance calculations assumed no biodegradation during anaerobic digestion and this appears to be valid based on the 18% increase between the input and output estrogen concentrations. Also, other studies indicate biodegradation does not occur at full-scale treatment for anaerobic digestion (Andersen, et al., 2003; Holbrook, et al., 2002; Janex-Habibi, et al., 2009; Muller, et al., 2010).

Estrogen load on the digested sludge is greater compared to the thickened sludge in the feed and the expected estrogen load from mass balance calculations. Assuming that estrogen adsorbed to the sludge prior to digestion remained adsorbed to the undestroyed solids, the expected load in the anaerobic sludge is 42.2 ng/g_{ss} (Appendix A). The measured estrogen load for digested sludge was 67.3 ng/g_{ss}, which is significantly higher. Similarly, the expected estrogen concentration in the aqueous phase, based on desorption from destroyed solids, was 659 ng/L_{ww} and the measured estrogen concentration was only

569 ng/L_{ww}. This suggests increased adsorption to the solid phase. As solids are destroyed during digestion, there is the potential for desorption to the aqueous phase. In this study and other studies (Andersen, et al., 2003; Esperanza, et al., 2007; Holbrook, et al., 2002), the digester supernatant had a high estrogen concentration, which is in agreement with estrogen desorption for destroyed solids. Since sludge has been shown to have high adsorption capacity for estrogen (Carballa, et al., 2008; Clara, et al., 2004; Ren, et al., 2007b), the newly desorbed estrogen from destroyed solids will readsorb to the remaining solids.

Anaerobic digestion may increase the potential for estrogen desorption from sludge, which is a major concern for land-applied sludge. In this study and another (Muller, et al., 2010), an increase in estrogen (44%, this study) was found in the centrate after dewatering digested sludge. In other instances, no effect on estrogen concentration was seen for centrifuging non-digested sludge (Muller, et al., 2008) or filter pressing non-digested sludge (Braga, et al., 2005b). Muller et al. (2010) also reported that thermal-pressurized treatment on digested sludge may have increased estrogen extractability. Considering that soil microbes biodegrade estrogen much slower than sewage microbes (Colucci and Topp, 2001; Jacobsen, et al., 2005), easily extractable estrogen may end up in surface water due to runoff or end up in groundwater through infiltration (Jacobsen, et al., 2005). Consequently, concerning estrogen, anaerobic digestion may not be beneficial for sludge that is intended for land application. Aerobic digestion, which shows greater estrogen removal (Esperanza, et al., 2007; Lorenzen, et al., 2004), may prove to be a good strategy to remove estrogen from wastewater. However, there is a significant power

cost associated with providing the needed aeration and useful byproducts, such as methane, are not generated (Metcalf & Eddy, 2003).

Table 5.4: Input and Output Estrogen Concentrations for Mass Balance Calculations

Treatment Process	Code	*Input	*Output	% Difference	**CV (%)
Gravity Thickener	GT 1	667 ng/L _{ww}	580 ng/L _{ww}	-13%	3.6, 30.8, 14.1
Gravity Thickener	GT 2	508 ng/L _{ww}	391 ng/L _{ww}	-23%	28.9, 2.7, 2.0
Centrifuge	CT 2	1964 ng/L _{ww}	2135 ng/L _{ww}	8.7%	8.1, 27.9, 11.9
Centrifuge	CT 3	1288 ng/L _{ww}	1819 ng/L _{ww}	41%	27.1, 15.4
Dissolved Air Flotation Thickening	DAFT	252 ng/L _{ww}	184 ng/L _{ww}	-27%	13.8, 6.7, 14.2
Anaerobic Digestion	AD	1660 ng/L _{ww}	1964 ng/L _{ww}	18%	44.5, 30.8, 2.7, 8.1, 14.4, 14.1

* Calculated using average E2 concentrations as shown in Appendix A

** Note: These are CV (%) values for the various input and output streams for the particular treatment process

CHAPTER 6

CONCLUSIONS, IMPLICATIONS AND RECOMMENDATIONS

6.1 Conclusions

This research aimed at investigating the influence of secondary treatment type and sludge handling processes on the fate of estrogen in wastewater and wastewater sludge. The study involved three secondary treatments (activated sludge, activated sludge with biological nutrient removal, and trickling filters) and four sludge handling processes (gravity thickeners, centrifuges, dissolved air flotation thickening, and anaerobic digestion) at two different WWTPs. The unique component of this study was that both WWTPs received wastewater from the same city.

In comparing these secondary treatment types, results from this study agreed with previously published work:

- Activated sludge treatments demonstrated greater estrogen removal compared to trickling filters, which has also been reported by other researchers (Janex-Habibi, et al., 2009; Johnson, et al., 2007; Ternes, et al., 1999b).
- BNR and non-BNR activated sludge treatment showed similar removal, which agrees with another study that found anaerobic and anoxic zones in WWTPs have little effect on estrogen removal (Joss, et al., 2004).

A new piece of information contributed by this study is the estrogen load on trickling filter solids (52.5 ng/g_{ss}). No other values were found in the literature. The higher estrogen load on the trickling filter solids can be explained considering:

- Biological sludge has a high capacity to adsorb estrogen and reported studies were unable to reach estrogen saturation in secondary sludge (Clara, et al., 2004; Ren, et al., 2007b).
- The equivalent SRT in the trickling filter is shorter (2.5 days) than in activated sludge, which means less time for biodegradation to occur.
- The oxygen concentration is lower in trickling filters compared to activated sludge, which results in slower biodegradation rates. Slower biodegradation rates mean that more estrogen will remain adsorbed to the trickling filter solids.
- High estrogen concentration in the aqueous phase (321.3±43.5 ng/L_{aq}) correlates to high estrogen load in the sludge.

The impact of gravity thickeners, centrifuges, and dissolved air flotation thickening (DAFT) on estrogen removal was examined:

- Centrifuges and gravity thickeners exhibited little influence on estrogen removal. Mass balance computations demonstrated that the input and output E2 contributions for the aqueous and solid phases were the same or similar when considering analytical errors.
- DAFT showed a slight decrease in estrogen concentration for the aqueous and solid phases. This can be attributed to some degree of biodegradation since DAFT is an aerated process.

Anaerobic digestion resulted in increased estrogen load on the sludge and a high estrogen concentration in the supernatant as a result of solids destruction and release of the adsorbed estrogen. Other studies involving full-scale WWTPs have found high estrogen concentration or high estrogenicity in the supernatant of anaerobic digesters (Andersen, et al., 2003; Esperanza, et al., 2007; Holbrook, et al., 2002). Based on mass balance calculations and an assumed destruction of volatile solids, the expected estrogen load for the digested sludge was 42.2 ng/g_{ss} and the expected estrogen concentration in the aqueous phase was 569 ng/L_{ww}. The measured estrogen concentrations were 67.3 ng/g_{ss} and 659 ng/L_{ww}, in the solid and aqueous phases, respectively. The estrogen load in the sludge was higher than expected and the estrogen load in the supernatant was lower than expected. The following points may explain why the estrogen concentrations deviated from the expected values:

- As solids were destroyed during digestion, estrogen desorbed from the solids and was released to the aqueous phase.
- Subsequently, estrogen was adsorbed by the remaining solids because digestion does not destroy all solids and sludge has been shown to have a very high adsorption capacity for estrogen (Carballa, et al., 2008; Ren, et al., 2007b).

6.2 Implications of Findings to Wastewater Treatment and Sludge Handling

Presently, there are no state or federally mandated discharge effluent standards or sludge application standards for estrogen. However, all three natural estrogens (E1, E2, and E3) and the synthetic estrogen (EE2) are included in the current Unregulated

Contaminant Monitoring Regulation (UCMR 3) for public water systems (US EPA UCMR3, 2012). There is the potential that estrogens will be regulated in the future, but no guidelines have been suggested yet. Arbitrary reference points of 80% and 90% estrogen removal in effluent discharge and 30 ng/g_{ss} estrogen load for biosolids are used to provide implications for wastewater treatment and land application of biosolids. The arbitrary 30 ng/g_{ss} reference point for biosolids was chosen based on estrogen load in secondary sludge for this study and others (Andersen, et al., 2003; Braga, et al., 2005b; Muller, et al., 2008; Ternes, et al., 2002). Compared to primary, digested or dewatered sludges, secondary sludge typically has the lowest estrogen load.

Current knowledge supports that activated sludge treatments, whether they include BNR or not, will typically have >80% estrogen removal in the effluent and meet the arbitrary lower reference point. Most WWTPs would not require any operational changes for 80% estrogen removal. To meet the higher reference point, WWTPs may need to make operational modifications, such as increasing the SRT for activated sludge. A few studies show that estrogen removal increases with higher SRT (Andersen, et al., 2003; Clara, et al., 2005; Johnson, et al., 2005; Racz, et al., 2012). In general, an SRT greater than 5 days for activated sludge will result in >90% removal (Esperanza, et al., 2007). Estrogen load on activated sludge was below 30 ng/g_{ss} for BNR and non-BNR activated sludges in this study. In general, activated sludge has a low estrogen load and would meet the reference point for land application.

Trickling filters are shown to have poor estrogen removal and would not achieve any of the arbitrary reference points for effluent discharge and land application. One solution for meeting the effluent discharge reference point would be to add an aeration

basin following the trickling filter. This addition would involve significant capital and operational costs. In this study, the combined TF and aeration basin performed as well as BNR treatment for estrogen removal. Trickling filter solids have a higher estrogen load compared to activated sludge and would not meet the reference point for land application. However, trickling filters produce far less solids than activated sludge treatment and these solids could be blended with the wasted activated sludge to minimize the impact on land application.

Mechanical and physical treatment processes, such as gravity thickeners and centrifuges, have no significant impact on estrogen removal. Although these processes do not decrease estrogen concentration, they also do not increase its availability. These sludge handling processes would not hinder or help a WWTP in meeting the reference points, but they would still be a necessary treatment step for reducing sludge volume.

Estrogen load on secondary activated sludge following DAFT was below 30 ng/g_{ss}, which meets the reference point for land application. For WWTPs with an estrogen load right at the reference point, such as those with low SRTs for activated sludge treatment, DAFT could be used to remove estrogen in both return streams and secondary sludge.

Anaerobic digestion was shown to increase estrogen concentration in the aqueous phase and the solid phase, so digested sludge would not meet the reference standard for land application. It also appears that estrogen extractability is greater after digestion (Holbrook, et al., 2002; Muller, et al., 2010). Estrogen could desorb from the sludge and enter surface water through runoff. Since soil microbes biodegrade estrogen slowly, estrogen could also infiltrate soil and end up in the groundwater. Anaerobic digestion would not be recommended for sludge that is intended for land application because of

high estrogen concentrations; however, anaerobic digestion is frequently used to meet Class A pathogen-reduction criteria (McFarland, 2001). Aerobic digestion is commonly used to treat mixtures of waste-activated sludge or trickling filter sludge and primary sludge (Metcalf & Eddy, 2003). Aerobic digestion would result in lower estrogen load on the sludge (Esperanza, et al., 2007). However, it may require a long SRT, such as 40 days at 20°C or 60 days at 15°C (Metcalf & Eddy, 2003), to achieve a significant reduction of pathogens. Operating aerobic digestion with a long SRT would lead to a high power cost.

6.3 Recommendations for Future Research

As continuation of this research, there are several studies that could be completed to provide further information on estrogen fate in wastewater treatment and estrogen adsorption to sludge:

- Confirm that trickling filter solids have a greater estrogen load compared to activated sludge.
- Complete an adsorption study, including the determination of Freundlich coefficients and adsorption kinetics, for primary sludge and compare the results with secondary sludge.
- Confirm the results for gravity thickeners and DAFT by investigating estrogen removal in multiple units. Use mass balance calculations to verify the degree of estrogen removal.

APPENDIX A

ESTROGEN MASS BALANCE CALCULATIONS

A.1. Terms

SS = suspended solids

VSS = volatile suspended solids

C_{sldg} = concentration of estrogen in dried sludge, reported as ng/g E2

C_{aq} = concentration of estrogen in aqueous phase, reported as ng/L E2

g_{ss} = grams of suspended solids

L_{aq} = liters, aqueous phase

L_{ww} = liters, wastewater stream (suspended solids and aqueous)

F = fraction of wastewater flow

A.2. Mass Balance Procedure

Direct comparison of E2 load before and after sludge handling processes provides a quick view, but it does not convey the complete story. Sludge handling processes result in changes in suspended solids concentration and in the formation of return streams. Suspended solids and return streams may contain estrogen and if these estrogen sources are neglected, this could skew interpretation. For example, a decrease in estrogen load on solids may appear at first as estrogen removal, unless a return stream or solids destruction

are taken into account. Therefore, interpretation of estrogen load data necessitates mass balance calculations.

For each of the sludge handling processes considered in this research, mass balance calculations were completed to compare the E2 load for the sludge, wastewater and return streams. Wherever possible, average values for E2 concentrations were used. Total suspended solids concentrations were estimated based on previously measured values at each WWTP (Jeong, 2004; Mota, 2001). In the calculations, the density of the sludge was assumed to be the same as that of water. The specific gravity of sludge is typically only slightly higher (1.005-1.02; Metcalf & Eddy, 2003) and therefore this assumption will not significantly affect the results.

Mass balance diagrams were drawn for each sludge handling process (Figures A.1-A.6). For all unit processes, except for the anaerobic digester, it was assumed that there was no formation or destruction of solids since these were mechanical and not biological processes.

Total E2 for a Wastewater Stream

The total E2 concentration for a wastewater stream was determined as the sum of E2 in the dried sludge (ng/g_{ss}) and E2 in the aqueous phase (ng/L_{aq}). E2 concentrations for dried sludge (C_{slgdg}) were converted based on the percent solids for that wastewater stream. For example, the E2 concentration for Plant A primary sludge (PC 2) is 40.0 ng/g_{ss} and the solids concentration for this stream is 6.0 g_{ss}/L_{ww} or 0.6% solids. Therefore, the sludge contributes 240 ng/L_{ww} to this wastewater stream.

$$40.0 \text{ ng/g}_{\text{ss}} * 6.0 \text{ g}_{\text{ss}}/\text{L}_{\text{ww}} = 240 \text{ ng/L}_{\text{ww}}$$

The contribution of the liquid stream is based on the E2 concentration in the aqueous phase (C_{aq}) and the fraction of the liquid in the wastewater stream ($100 - 0.6\%$ solids = 99.4% aqueous). In this case, a liquid stream with 429 ng/L_{aq} E2 concentration contributes 427 ng/L_{ww}.

$$0.994 \text{ L}_{aq}/\text{L}_{ww} * 429 \text{ ng}/\text{L}_{aq} = 427 \text{ ng}/\text{L}_{ww}$$

The combined E2 for this wastewater stream is 667 ng/L_{ww}. This represents the primary sludge stream entering the Gravity Thickener and will be used in another example below.

Sludge E2 + Aqueous phase E2 = Total E2 in wastewater stream

$$240 \text{ ng}/\text{L}_{ww} + 427 \text{ ng}/\text{L}_{ww} = 667 \text{ ng}/\text{L}_{ww}$$

Determining Fraction of Flow for Output Streams

The fraction of flow for each stream was determined by a mass balance of suspended solids. Two equations were written: one equation for the suspended solids input and one equation for the suspended solids output. The input equation used the percent solids for the feed wastewater stream and was assigned a fraction of 1 (i.e., 100%). The output equation was a sum of the output percent solids multiplied by a fraction of flow. Initially, the fractions were assigned as 0.5 (50%) to each output.

$$\text{Input} = \text{SS}_{in} * F_{in}$$

$$\text{Output} = \text{SS}_{out1} * F_{out1} + \text{SS}_{out2} * F_{out2}$$

Where SS = concentration of suspended solids

F = fraction of flow (1 for F_{in} ; sum of $F_{out} = 1$)

The Solver function on Microsoft Excel ® was used to determine the correct fraction for the output streams. This was done by setting the output equation equal to the input

equation, setting the output fractions as variables, and constraining the variables to be greater than zero and sum to 1.

$$SS_{in} * F_{in} = SS_{out1} * F_{out1} + SS_{out2} * F_{out2}$$

$$\text{Variables: } F_{out1}, F_{out2}$$

$$F_{out1}, F_{out2} > 0$$

$$F_{out1} + F_{out2} = 1$$

Mass Balance of E2 in Thickeners and Centrifuges

Thickeners and centrifuges have a single input stream and two output streams. Once the total E2 is calculated for each wastewater stream and the fraction of flow for the output streams is determined, then a mass balance can be completed. For example, Plant A Gravity Thickener (GT 2) has an input stream of primary sludge and the outputs are thickened primary sludge and a return stream. The solids concentrations are 6 g_{ss}/L_{ww}, 39.095 g_{ss}/L_{ww}, and 0.1033 g_{ss}/L_{ww}, respectively. Using Solver, the equation below resulted in F_{out1} = 0.151 and F_{out2} = 0.849 for the output flows.

$$SS_{in} * F_{in} = SS_{out1} * F_{out1} + SS_{out2} * F_{out2}$$

$$6 * 1 = 39.095 * F_{out1} + 0.1033 * F_{out2}$$

The E2 contribution for the input wastewater stream, consisting of sludge and an aqueous phase, was calculated as shown in the first section:

$$\text{Input, primary sludge} = 240 \text{ ng/L}_{ww} + 427 \text{ ng/L}_{ww} = 667 \text{ ng/L}_{ww}$$

The E2 contributions for the output wastewater streams were calculated as shown in the first section:

$$\text{Output, thickened primary sludge} = 56.9 \text{ ng/g}_{ss} * 39.095 \text{ g}_{ss}/\text{L}_{ww} = 2224 \text{ ng/L}_{ww}$$

$$\text{Output, return stream} = 288 \text{ ng/L}_{liq} * (100 - 0.1033) = 288 \text{ ng/L}_{ww}$$

Lastly, the output stream E2 contributions were multiplied by the fraction of flow and a total output was determined.

$$\text{Thickened primary sludge} = 2224 \text{ ng/L}_{\text{ww}} * 0.151 = 336 \text{ ng/L}_{\text{ww}}$$

$$\text{Return stream} = 288 \text{ ng/L}_{\text{ww}} * 0.849 = 244 \text{ ng/L}_{\text{ww}}$$

$$\text{Total output} = 336 \text{ ng/L}_{\text{ww}} + 244 \text{ ng/L}_{\text{ww}} = 580 \text{ ng/L}_{\text{ww}}$$

The total input and outputs were compared to see if there was a mass balance overall. If they differed, the percent difference was calculated and compared to the coefficients of variation from the E2 analyses to see if the difference was significant or not.

$$\text{Total input} = 667 \text{ ng/L}_{\text{ww}}$$

$$\text{Total output} = 580 \text{ ng/L}_{\text{ww}}$$

$$\text{Percent difference} = (580 - 667) / 667 * 100 = \mathbf{-13\%}$$

Coefficients of variation

Primary sludge 4%

Thickened primary sludge 31%

Recycle stream 14%

In this case, the percent difference is smaller than the coefficients of variation, so there is no significant difference between the input and output flows.

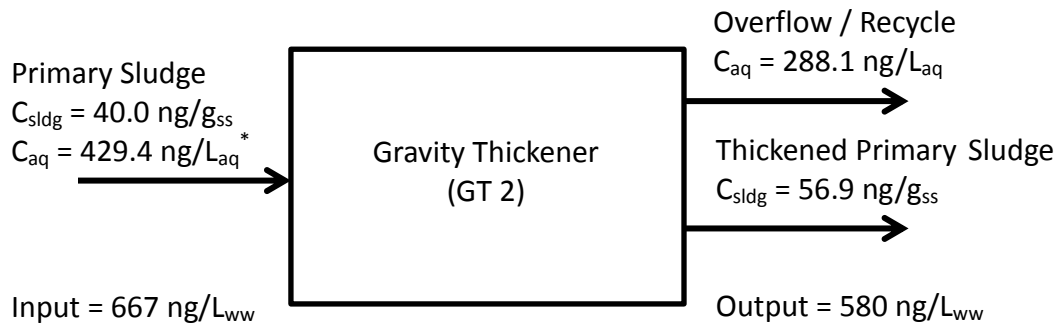

Figure A.1: Plant A, Gravity Thickener (GT 2)

* Assuming same E2 as primary influent

Mass Balance of E2 in Digester

Unlike centrifuges and thickeners, the suspended solids concentration in the digester will change as a result of solids destruction. For the digestion mass balance calculations, the following assumption was made:

- Anaerobic digestion results in the destruction of 60% of the volatile solids present in the primary sludge and 20% of the volatile solids present in the secondary sludge (Metcalf & Eddy, 2003; Grady et al., 1999)

The total input E2 for the digester was determined based on the actual ratio of thickened primary and centrifuged secondary sludges entering the digester. The concentrations for GT 1 and GT 2 were averaged (47.8 ng/g_{ss}) to obtain the E2 load for thickened primary sludge. For digestion calculations, the primary and secondary sludges were treated independently because solids destruction due to digestion is not equal. A volume of 1 liter was used to simplify calculations.

Digester sludge ratio: 80% thickened primary sludge and 20% centrifuged secondary sludge by volume (personal communication, Daniel Fischer WPCF)

Thickened primary sludge E2: $47.8 \text{ ng/g}_{\text{SS}} * 35 \text{ g}_{\text{SS}}/\text{L}_{\text{WW}} = 1673 \text{ ng}/\text{L}_{\text{WW}}$

For 1 liter entering digester: $0.80 * 1673 \text{ ng} = 1338.4 \text{ ng E2}$

Centrifuged secondary sludge E2: $32.2 \text{ ng/g}_{\text{SS}} * 50 \text{ g}_{\text{SS}}/\text{L}_{\text{WW}} = 1610 \text{ ng}/\text{L}_{\text{WW}}$

For 1 liter entering digester: $0.20 * 1610 \text{ ng} = 322.0 \text{ ng E2}$

1 liter of mixed sludge entering digester contains:

1338.4 ng E2 for thickened primary sludge

322.0 ng E2 for centrifuged secondary sludge

The initial solids entering the digester were determined. Since digestion removes volatile suspended solids (VSS) and not fixed suspended solids (FSS), these were treated independently in the calculations. Both the primary and secondary sludges are composed of 76% VSS and 24% FSS (personal communication, Daniel Fischer WPCF).

Feed primary sludge solids: $35 \text{ g}_{\text{SS}}/\text{L}_{\text{WW}}$, 80% of digester input

Feed primary sludge solids in 1 liter: $0.8 * 35 \text{ g SS} = 28 \text{ g SS}$

Feed VSS for primary sludge: $0.76 * 28 \text{ g} = 21.3 \text{ g VSS}$

Feed secondary sludge solids: $50 \text{ g}_{\text{SS}}/\text{L}_{\text{WW}}$, 20% of digester input

Feed secondary sludge solids in 1 liter: $0.2 * 50 \text{ g SS} = 10 \text{ g SS}$

Feed VSS for secondary sludge: $0.76 * 10 \text{ g} = 7.6 \text{ g VSS}$

Next, the amount of solids destroyed and the solids remaining after digestion were calculated. As stated previously, it was assumed that 60% of the primary VSS and 20% of the secondary VSS were destroyed. The E2 associated with the destroyed VSS was

also calculated. For these calculations, biodegradation of E2 in the digester was ignored. If biodegradation did occur, this would be apparent in the final calculated values as a decrease between the input and output.

$$\text{Loss of VSS} = \% \text{ destroyed} * \text{VSS of sludge}$$

$$\text{E2 associated with VSS} = 76\% \text{ VSS} * \text{initial E2 entering digester}$$

$$\text{E2 associated with loss of VSS} = \% \text{ destroyed} * \text{E2 associated with VSS}$$

$$\text{Remaining solids} = \text{Initial solids} - \text{Loss of VSS}$$

$$\text{Loss of VSS in primary (1}^\circ\text{) sludge: } 0.6 * 21.3 \text{ g} = 12.8 \text{ g VSS}$$

$$\text{E2 associated with 1}^\circ\text{ sludge VSS: } 0.76 * 1338.4 \text{ ng} = 1017.2 \text{ ng E2}$$

$$\text{E2 associated with destroyed 1}^\circ\text{ sludge VSS: } 0.6 * 1017.2 \text{ ng} = 610.3 \text{ ng E2}$$

$$\text{Loss of VSS in secondary (2}^\circ\text{) sludge: } 0.2 * 7.6 \text{ g} = 1.5 \text{ g VSS}$$

$$\text{E2 associated with 2}^\circ\text{ sludge VSS: } 0.76 * 322.0 \text{ ng} = 244.7 \text{ ng E2}$$

$$\text{E2 associated with destroyed 2}^\circ\text{ sludge VSS: } 0.2 * 244.7 \text{ ng} = 48.9 \text{ ng E2}$$

$$\text{Overall E2 associated with destroyed VSS: } 610.3 \text{ ng} + 48.9 \text{ ng} = 659.2 \text{ ng E2}$$

$$\text{Remaining solids in 1}^\circ\text{ sludge: } 28 \text{ g SS} - 12.8 \text{ g VSS} = 15.2 \text{ g SS}$$

$$\text{Remaining solids in 2}^\circ\text{ sludge: } 10 \text{ g SS} - 1.5 \text{ g VSS} = 8.5 \text{ g SS}$$

$$\text{Overall remaining solids in sludge: } 15.2 \text{ g SS} + 8.5 \text{ g SS} = 23.7 \text{ g SS}$$

From this, the expected E2 remaining was calculated for each sludge and overall. The expected E2 load on the sludge was determined based on the expected E2 remaining and the overall remaining solids in the sludge.

$$\text{Expected E2 remaining for 1}^\circ\text{ sludge: } 1338.4 \text{ ng} - 610.3 \text{ ng} = 728.1 \text{ ng E2}$$

$$\text{Expected E2 remaining for 2}^\circ\text{ sludge: } 322.0 \text{ ng} - 48.9 \text{ ng} = 273.1 \text{ ng E2}$$

Expected overall E2 remaining in sludge: $728.1 \text{ ng} + 273.1 \text{ ng} = 1001.2 \text{ ng E2}$

Expected E2 sludge loading: $1001.2 \text{ ng E2} / 23.7 \text{ g SS} = 42.2 \text{ ng/g}_{\text{ss}}$

Next, the measured E2 levels were used to calculate the overall E2 contribution in the sludge and supernatant of the digested wastewater, as shown below. The contribution of E2 from the digested sludge was determined from the E2 load ($67.3 \text{ ng/g}_{\text{ss}}$) and the solids concentration ($20.728 \text{ g}_{\text{ss}}/\text{L}_{\text{ww}}$). The contribution from the supernatant was based on the E2 concentration in the aqueous phase ($C_{\text{aq}} = 581.4 \text{ ng/L}_{\text{aq}}$) and the fraction of the liquid in the wastewater stream ($100 - 2.0728\% \text{ solids} = 97.93\%$). The overall E2 contribution after digestion was the sum of the contributions from the digested sludge and supernatant.

E2 contribution from sludge: $67.3 \text{ ng/g}_{\text{ss}} * 20.728 \text{ g}_{\text{ss}}/\text{L}_{\text{ww}} = 1395.0 \text{ ng/L}_{\text{ww}}$

E2 contributed from supernatant: $581.4 \text{ ng/L}_{\text{aq}} * 0.9793 \text{ L}_{\text{aq}}/\text{L}_{\text{ww}} = 569.3 \text{ ng/L}_{\text{ww}}$

Overall E2 after digestion: $1395.0 \text{ ng/L}_{\text{ww}} + 569.3 \text{ ng/L}_{\text{ww}} = 1964.3 \text{ ng/L}_{\text{ww}}$

The expected E2 values were compared to the measured E2 in the sludge and supernatant of the digested wastewater. The percent difference was calculated and compared to the coefficients of variation from the E2 analyses to see if the difference was significant or not.

Input, E2 before digestion = $1660.4 \text{ ng/L}_{\text{ww}}$

Output, E2 after digestion = $1964.3 \text{ ng/L}_{\text{ww}}$

% difference: $100 * (1964.3 - 1660.4) / 1660.4 = 18.3\%$

Measured E2 contribution for sludge: $1395 \text{ ng/L}_{\text{ww}}$

Expected E2 contribution for sludge: $1001.2 \text{ ng/L}_{\text{ww}}$

% difference: $100 * (1395.0 - 1001.2) / 1001.2 = 39.3\%$

Measured E2 load on sludge: $67.3 \text{ ng/g}_{\text{ss}}$

Expected E2 load on sludge: 42.2 ng/g_{SS}

$$\% \text{ difference: } 100 * (67.3 - 42.2) / 42.2 = 59.4\%$$

Measured E2 contribution for supernatant: 569.3 ng/L_{ww}

Expected E2 for supernatant (from destroyed VSS): 659.3 ng/L_{ww}

$$\% \text{ difference: } 100 * (569.3 - 659.3) / 659.3 = -13.6 \%$$

Coefficients of variation:

Thickened primary sludge, 30.8%

Secondary centrifuged sludge, 44.5%

Digested sludge, 8.1%

Supernatant of digested sludge, n/a

A.3. Summary of Mass Balances

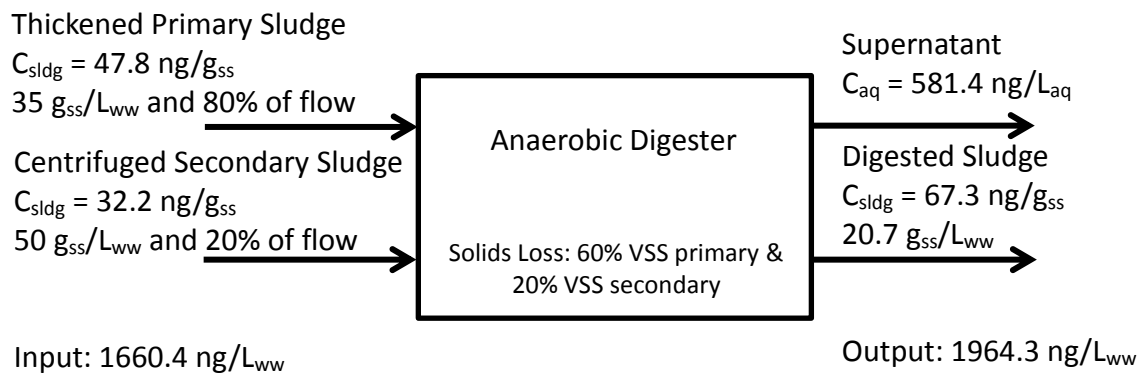

Figure A.2: Plant A, Anaerobic Digester (AD)

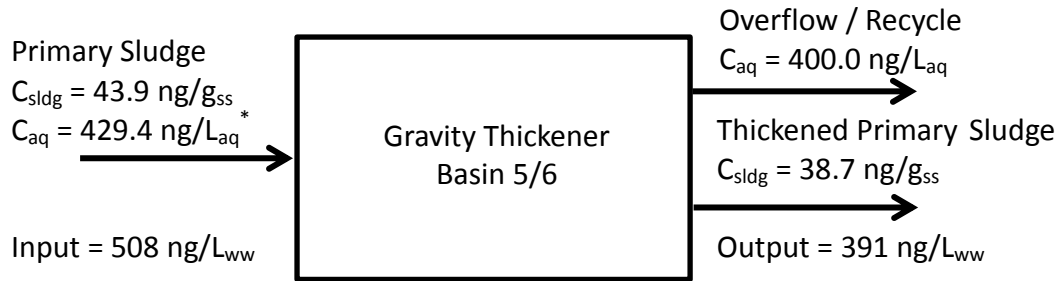

Figure A.3: Plant A, Gravity Thickener (GT 1)

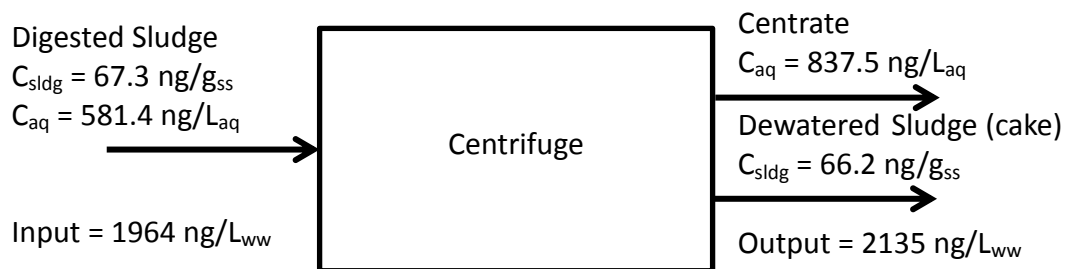

Figure A.4: Plant A, Dewatering Centrifuge (CT 2)

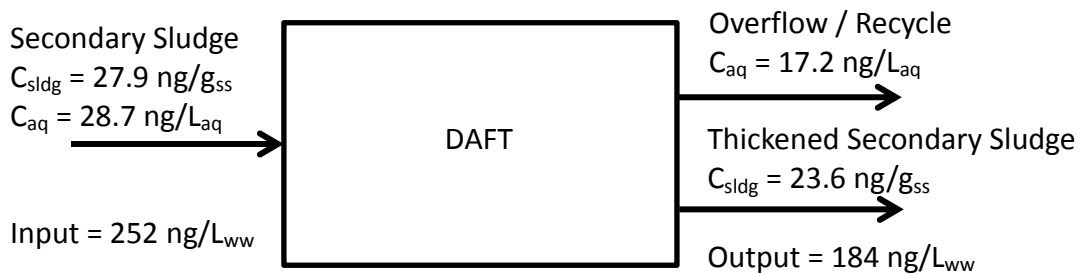

Figure A.5: Plant B, Dissolved Air Flotation Thickening (DAFT)

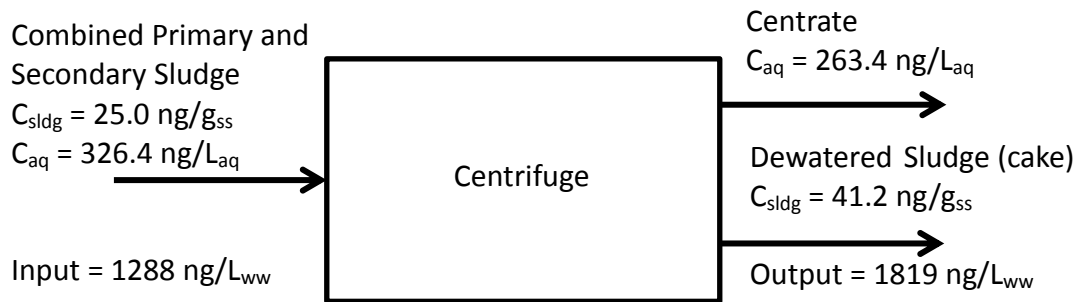

Figure A.6: Plant B, Dewatering Centrifuge (CT 3)

A.4. Summary of Mass Balance Raw Data and E2 Contributions

Table A.1: Input, Output, Raw Data and E2 Contributions for Mass Balance Calculations

Plant A, GT 1		Measured value		Conversion		Fraction	E2 Contribution
Input	667	Primary	40 ng/g	240	ng/L	1	240
Output	581	Influent	429.4 ng/L			0.94	427
Difference	-86	Thickened	56.9 ng/g	2225	ng/L	0.151	336
% Diff	-12.9%	Recycle	288.1 ng/L			0.849	245

Plant A, GT 2		Measured value		Conversion		Fraction	E2 Contribution
Input	508	Primary	43.9 ng/g	79.0	ng/L	1	79
Output	391	Influent	429.4 ng/L			0.9982	429
Difference	-117	Thickened	38.7 ng/g	344	ng/L	0.167	57
% Diff	-23%	Recycle	400 ng/L			0.833	333

Plant A, CT 2		Measured value		Conversion		Fraction	E2 Contribution
Input	1964	Digest. Sldg	67.3 ng/g	1395	ng/L	1	1395
Output	2135	Digest. Liq	581.4 ng/L			0.97927	569
Difference	171	Dewater.	66.2 ng/g	19722	ng/L	0.069	1355
% Diff	9%	Centrate	837.5 ng/L			0.931	780

Plant A, AD		Measured value		Conversion		Fraction	E2 Contribution
Input	1660	Prim. Sldg	47.8 ng/g	1338	ng/L	1	1338
Output	1964	Sec. Sldg	32.2 ng/g	322	ng/L	1	322
Difference	304	Digest. Sldg	67.3 ng/g	1395	ng/L	1	1395
% Diff	18%	Digest. Liq	581.4 ng/L			0.979	569

Plant B, DAFT		Measured value		Conversion		Fraction	E2 Contribution
Input	251.7	Sec. AS	27.9 ng/g	223.2	ng/L	1	223.2
Output	183.8	Sec. AS Liq.	28.7 ng/L			0.992	28.5
Difference	-68	DAFT Sldg	23.6 ng/g	778.8	ng/L	0.219	170.4
% Diff	-27%	Recycle	17.2 ng/L			0.781	13.4

Plant B, CT 3		Measured value		Conversion		Fraction	E2 Contribution
Input	1288.7	Combined	25 ng/g	975.0	ng/L	1	975.0
Output	1818.7	Comb. Liq.	326.4 ng/L			0.961	313.7
Difference	530	Dewater.	41.2 ng/g	10712.0	ng/L	0.149	1594.5
% Diff	41%	Centrate	263.4 ng/L			0.851	224.2

REFERENCES

- Adlercreutz, H., Järvenpää, P., 1982. Assay of estrogens in human feces. *J. Steroid Biochem.* 17, 639-645.
- Allinson, M., Shiraishi, F., Allinson, G., 2011. A comparison of recombinant receptor-reporter gene bioassays and a total estrogen enzyme linked immunosorbent assay for the rapid screening of estrogenic activity in natural and waste waters. *Bull. Environ. Contam. Toxicol.* 86, 461-464.
- Andersen, H.R., Hansen, M., Kjlholt, J., Stuer-Lauridsen, F., Ternes, T., Halling-Srensen, B., 2005. Assessment of the importance of sorption for steroid estrogens removal during activated sludge treatment. *Chemosphere.* 61, 139-146.
- Andersen, H., Siegrist, H., Halling-Srensen, B., Ternes, T.A., 2003. Fate of estrogens in a municipal sewage treatment plant. *Environmental Science and Technology.* 37, 4021-4026.
- Baronti, C., Curini, R., D'Ascenzo, G., Di Corcia, A., Gentili, A., Samperi, R., 2000. Monitoring natural and synthetic estrogens at activated sludge sewage treatment plants and in a receiving river water. *Environmental Science and Technology.* 34, 5059-5066.
- Boyd, G.R., Reemtsma, H., Grimm, D.A., Mitra, S., 2003. Pharmaceuticals and personal care products (PPCPs) in surface and treated waters of Louisiana, USA and Ontario, Canada. *Sci. Total Environ.* 311, 135-149.
- Braga, O., Smythe, G.A., Schafer, A.I., Feitz, A.J., 2005a. Steroid estrogens in primary and tertiary wastewater treatment plants. *Water Science and Technology.* 52, 273-278.
- Braga, O., Smythe, G.A., Schafer, A.I., Feitz, A.J., 2005b. Fate of steroid estrogens in Australian inland and coastal wastewater treatment plants. *Environmental Science and Technology.* 39, 3351-3358.
- Carballa, M., Omil, F., Alder, A.C., Lema, J.M., 2006. Comparison between the conventional anaerobic digestion of sewage sludge and its combination with a chemical or thermal pre-treatment concerning the removal of pharmaceuticals and personal care products. *Water Science and Technology.* 53, 109-117.
- Carballa, M., Fink, G., Omil, F., Lema, J.M., Ternes, T., 2008. Determination of the solid-water distribution coefficient (K_d) for pharmaceuticals, estrogens and musk fragrances in digested sludge. *Water Res.* 42, 287-295.

- Carballa, M., Omil, F., Lema, J.M., Llompart, M., Garcia-Jares, C., Rodriguez, I., Gomez, M., Ternes, T., 2004. Behavior of pharmaceuticals, cosmetics and hormones in a sewage treatment plant. *Water Res.* 38, 2918-2926.
- Chen, X., Hu, J., 2010. Adsorption of natural estrogens and their conjugates by activated sludge. *Water Air Soil Pollut.* 206, 251-261.
- Chiu, T.Y., Koh, Y.K.K., Paterakis, N., Boobis, A.R., Cartmell, E., Richards, K.H., Lester, J.N., Scrimshaw, M.D., 2009. The significance of sample mass in the analysis of steroid estrogens in sewage sludges and the derivation of partition coefficients in wastewaters. *Journal of Chromatography A.* 1216, 4923-4926.
- Clara, M., Kreuzinger, N., Strenn, B., Gans, O., Kroiss, H., 2005. The solids retention time - A suitable design parameter to evaluate the capacity of wastewater treatment plants to remove micropollutants. *Water Res.* 39, 97-106.
- Clara, M., Strenn, B., Saracevic, E., Kreuzinger, N., 2004. Adsorption of bisphenol-A, 17 β -estradiol and 17 α -ethinylestradiol to sewage sludge. *Chemosphere.* 56, 843-851.
- Colucci, M.S., Topp, E., 2001. Persistence of estrogenic hormones in agricultural soils: II. 17-ethinylestradiol. *J. Environ. Qual.* 30, 2077-2080.
- Combalbert, S., Hernandez-Raquet, G., 2010. Occurrence, fate, and biodegradation of estrogens in sewage and manure. *Appl. Microbiol. Biotechnol.* 86, 1671-1692.
- D'Ascenzo, G., Di Corcia, A., Gentili, A., Mancini, R., Mastropasqua, R., Nazzari, M., Samperi, R., 2003. Fate of natural estrogen conjugates in municipal sewage transport and treatment facilities. *Sci. Total Environ.* 302, 199-209.
- Daughton, C.G., Ternes, T.A., 1999. Pharmaceuticals and personal care products in the environment: Agents of subtle change? *Environmental Health Perspectives Supplements.* 107, 907.
- des Mes, T.Z.D., Kujawa-Roeleveld, K., Zeeman, G., Lettinga, G., 2008. Anaerobic biodegradation of estrogens - Hard to digest. *Water Science and Technology.* 57, 1177-1182.
- Esperanza, M., Suidan, M.T., Marfil-Vega, R., Gonzalez, C., Sorial, G.A., McCauley, P., Brenner, R., 2007. Fate of sex hormones in two pilot-scale municipal wastewater treatment plants: Conventional treatment. *Chemosphere.* 66, 1535-1544.
- Farre, M., Brix, R., Kuster, M., Rubio, F., Goda, Y., De Alda, Maria J. Lopez, Barcelo, D., 2006. Evaluation of commercial immunoassays for the detection of estrogens in water by comparison with high-performance liquid chromatography tandem mass spectrometry HPLC-MS/MS (QqQ). 385, 1001-1011.

- Gabet-Giraud, V., Miege, C., Choubert, J.M., Ruel, S.M., Coquery, M., 2010a. Occurrence and removal of estrogens and beta blockers by various processes in wastewater treatment plants. *Sci. Total Environ.* 408, 4257-4269.
- Gabet-Giraud, V., Miege, C., Herbreteau, B., Hernandez-Raquet, G., Coquery, M., 2010b. Development and validation of an analytical method by LC-MS/MS for the quantification of estrogens in sewage sludge. *Analytical and Bioanalytical Chemistry.* 396, 1841-1851.
- Gaulke, L.S., Strand, S.E., Kalthorn, T.F., Stensel, H.D., 2008. 17-ethinylestradiol transformation via abiotic nitration in the presence of ammonia oxidizing bacteria. *Environmental Science and Technology.* 42, 7622-7627.
- Goda, Y., Kobayashi, A., Fukuda, K., Fujimoto, S., Ike, M., Fujita, M., 2000. Development of the ELISAs for detection of hormone-disrupting chemicals. *Water Science and Technology.* 42, 81-88.
- Gomes, R.L., Avcioglu, E., Scrimshaw, M.D., Lester, J.N., 2004. Steroid-estrogen determination in sediment and sewage sludge: A critique of sample preparation and chromatographic/mass spectrometry considerations, incorporating a case study in method development. *TrAC - Trends in Analytical Chemistry.* 23, 737-744.
- Gomes, R.L., Scrimshaw, M.D., Lester, J.N., 2009. Fate of conjugated natural and synthetic steroid estrogens in crude sewage and activated sludge batch studies. *Environmental Science and Technology.* 43, 3612-3618.
- Gunnarsson, L., Adolfsson-Erici, M., Bjorlenius, B., Rutgersson, C., Forlin, L., Larsson, D.G.J., 2009. Comparison of six different sewage treatment processes-Reduction of estrogenic substances and effects on gene expression in exposed male fish. *Sci. Total Environ.* 407, 5235-5242.
- Hanselman, T.A., Graetz, D.A., Wilkie, A.C., Szabo, N.J., Diaz, C.S., 2006. Determination of steroidal estrogens in flushed dairy manure wastewater by gas chromatography-mass spectrometry. *J. Environ. Qual.* 35, 695-700.
- Hashimoto, T., Murakami, T., 2009. Removal and degradation characteristics of natural and synthetic estrogens by activated sludge in batch experiments. *Water Res.* 43, 573-582.
- Hashimoto, T., Onda, K., Nakamura, Y., Tada, K., Miya, A., Murakami, T., 2007. Comparison of natural estrogen removal efficiency in the conventional activated sludge process and the oxidation ditch process. *Water Res.* 41, 2117-2126.

- Hintemann, T., Schneider, C., Scholer, H.F., Schneider, R.J., 2006. Field study using two immunoassays for the determination of estradiol and ethinylestradiol in the aquatic environment. *Water Res.* 40, 2287-2294.
- Hirobe, M., Goda, Y., Okayasu, Y., Tomita, J., Takigami, H., Ike, M., Tanaka, H., 2006. The use of enzyme-linked immunosorbent assays (ELISA) for the determination of pollutants in environmental and industrial wastes. 54, 1-9.
- Holbrook, R.D., Novak, J.T., Grizzard, T.J., Love, N.G., 2002. Estrogen receptor agonist fate during wastewater and biosolids treatment processes: A mass balance analysis. *Environmental Science and Technology.* 36, 4533-4539.
- Houtman, C.J., Van Houten, Y.K., Leonards, P.E.G., Brouwer, A., Lamoree, M.H., Legler, J., 2006. Biological validation of a sample preparation method for ER-CALUX bioanalysis of estrogenic activity in sediment using mixtures of xeno-estrogens. *Environmental Science and Technology.* 40, 2455-2461.
- Jacobsen, A., Lorenzen, A., Chapman, R., Topp, E., 2005. Persistence of testosterone and 17-estradiol in soils receiving swine manure or municipal biosolids. *J. Environ. Qual.* 34, 861-871.
- Janex-Habibi, M., Huyard, A., Esperanza, M., Bruchet, A., 2009. Reduction of endocrine disruptor emissions in the environment: The benefit of wastewater treatment. *Water Res.* 43, 1565-1576.
- Jobling, S., Nolan, M., Tyler, C.R., Brighty, G., Sumpter, J.P., 1998. Widespread sexual disruption in wild fish. *Environmental Science and Technology.* 32, 2498-2506.
- Johnson, A.C., Aerni, H.-., Gerritsen, A., Gibert, M., Giger, W., Hylland, K., Jurgens, M., Nakari, T., Pickering, A., Suter, M.J.-., Svenson, A., Wettstein, F.E., 2005. Comparing steroid estrogen, and nonylphenol content across a range of European sewage plants with different treatment and management practices. *Water Res.* 39, 47-58.
- Johnson, A.C., Williams, R.J., Simpson, P., Kanda, R., 2007. What difference might sewage treatment performance make to endocrine disruption in rivers? *Environmental Pollution.* 147, 194-202.
- Jones-Lepp, T., Stevens, R., 2007. Pharmaceuticals and personal care products in biosolids/sewage sludge: The interface between analytical chemistry and regulation. 387, 1173-1183.
- Joss, A., Andersen, H., Ternes, T., Richle, P.R., Siegrist, H., 2004. Removal of estrogens in municipal wastewater treatment under aerobic and anaerobic conditions: Consequences for plant optimization. *Environmental Science and Technology.* 38, 3047-3055.

Khanal, S.K., Xie, B., Thompson, M.L., Sung, S., Ong, S., Van Leeuwen, J., 2006. Fate, transport and biodegradation of natural estrogens in the environment and engineered systems. *Environmental Science and Technology*. 40, 6537-6546.

Koh, Y.K.K., Chiu, T.Y., Boobis, A.R., Scrimshaw, M.D., Bagnall, J.P., Soares, A., Pollard, S., Cartmell, E., Lester, J.N., 2009. Influence of operating parameters on the biodegradation of steroid estrogens and nonylphenolic compounds during biological wastewater treatment processes. *Environmental Science and Technology*. 43, 6646-6654.

Lai, K.M., Johnson, K.L., Scrimshaw, M.D., Lester, J.N., 2000. Binding of waterborne steroid estrogens to solid phases in river and estuarine systems. *Environmental Science and Technology*. 34, 3890-3894.

Lai, K.M., Scrimshaw, M.D., Lester, J.N., 2002. Prediction of the bioaccumulation factors and body burden of natural and synthetic estrogens in aquatic organisms in the river systems. *Sci. Total Environ*. 289, 159-168.

Lee, H., Liu, D., 2002. Degradation of 17-estradiol and its metabolites by sewage bacteria. *Water Air Soil Pollut*. 134, 353-368.

Li, Z., Wang, S., Lee, N.A., Allan, R.D., Kennedy, I.R., 2004. Development of a solid-phase extraction - Enzyme-linked immunosorbent assay method for the determination of estrone in water. *Anal. Chim. Acta*. 503, 171-177.

Lorenzen, A., Hendel, J.G., Conn, K.L., Bittman, S., Kwabiah, A.B., Lazarovitz, G., Masse, D., McAllister, T.A., Topp, E., 2004. Survey of hormone activities in municipal biosolids and animal manures. *Environ. Toxicol*. 19, 216-225.

Matsui, S., Takigami, H., Matsuda, T., Taniguchi, N., Adachi, J., Kawami, H., Shimizu, Y., 2000. Estrogen and estrogen mimics contamination in water and the role of sewage treatment. 42, 173-179.

Miege, C., Gabet, V., Coquery, M., Karolak, S., Jugan, M.-., Oziol, L., Levi, Y., Chevreuril, M., 2009. Evaluation of estrogenic disrupting potency in aquatic environments and urban wastewaters by combining chemical and biological analysis. *TrAC - Trends in Analytical Chemistry*. 28, 186-195.

Muller, M., Combalbert, S., Delgenes, N., Bergheaud, V., Rocher, V., Benoit, P., Delgenes, J., Patureau, D., Hernandez-Raquet, G., 2010. Occurrence of estrogens in sewage sludge and their fate during plant-scale anaerobic digestion. *Chemosphere*. 81, 65-71.

Muller, M., Rabenoelina, F., Balaguer, P., Patureau, D., Lemenach, K., Budzinski, H., Barcelo, D., Alda, L.D., Kuster, M., Delgenes, J., Hernandez-Raquet, G., 2008. Chemical and biological analysis of endocrine-disrupting hormones and estrogenic activity in an

advanced sewage treatment plant. *Environmental Toxicology and Chemistry*. 27, 1649-1658.

Nieto, A., Borrull, F., Pocurull, E., Marce, R.M., 2008. Determination of natural and synthetic estrogens and their conjugates in sewage sludge by pressurized liquid extraction and liquid chromatography-tandem mass spectrometry. *Journal of Chromatography A*. 1213, 224-230.

Racz, L., Muller, J.G., Goel, R.K., 2012. Fate of selected estrogens in two laboratory scale sequencing batch reactors fed with different organic carbon sources under varying solids retention times. *Bioresour. Technol.* 110, 35-42.

Ren, Y., Nakano, K., Nomura, M., Chiba, N., Nishimura, O., 2007a. Effects of bacterial activity on estrogen removal in nitrifying activated sludge. *Water Res.* 41, 3089-3096.

Ren, Y., Nakano, K., Nomura, M., Chiba, N., Nishimura, O., 2007b. A thermodynamic analysis on adsorption of estrogens in activated sludge process. *Water Res.* 41, 2341-2348.

Reungoat, J., Macova, M., Escher, B.I., Carswell, S., Mueller, J.F., Keller, J., 2010. Removal of micropollutants and reduction of biological activity in a full scale reclamation plant using ozonation and activated carbon filtration. *Water Res.* 44, 625-637.

Roda, A., Mirasoli, M., Michelini, E., Magliulo, M., Simoni, P., Guardigli, M., Curini, R., Sergi, M., Marino, A., 2006. Analytical approach for monitoring endocrine-disrupting compounds in urban waste water treatment plants. *Analytical and Bioanalytical Chemistry*. 385, 742-752.

Routledge, E.J., Sheahan, D., Desbrow, C., Brighty, G.C., Waldock, M., Sumpter, J.P., 1998. Identification of estrogenic chemicals in STW effluent. 2. In vivo responses in trout and roach. *Environmental Science and Technology*. 32, 1559-1565.

Routledge, E.J., Sumpter, J.P., 1996. Estrogenic activity of surfactants and some of their degradation products assessed using a recombinant yeast screen. *Environmental Toxicology and Chemistry*. 15, 241-241.

Shi, J.H., Suzuki, Y., Nakai, S., Hosomi, M., 2004a. Microbial degradation of estrogens using activated sludge and night soil-composting microorganisms. *Water Science and Technology*. 50, 153-159.

Shi, J., Fujisawa, S., Nakai, S., Hosomi, M., 2004b. Biodegradation of natural and synthetic estrogens by nitrifying activated sludge and ammonia-oxidizing bacterium *Nitrosomonas europaea*. *Water Res.* 38, 2322-2329.

- Shi, W., Zhao, L., Li, G., Cui, F., 2010. Removal pathway and mechanisms of 17-ethinylestradiol in eco-pond systems for wastewater treatment. *Harbin Gongye Daxue Xuebao/Journal of Harbin Institute of Technology*. 42, 1269-1273.
- Snyder, S., Vanderford, B., Pearson, R., Quinones, O., Yoon, Y., 2003a. Analytical methods used to measure endocrine disrupting compounds in water. *Pract. Periodical Hazard. , Toxic, Radioact. Waste Manage.* 7, 224-234.
- Snyder, S.A., Westerhoff, P., Yoon, Y., Sedlak, D.L., 2003b. Pharmaceuticals, personal care products, and endocrine disruptors in water: Implications for the water industry. *Environ. Eng. Sci.* 20, 449-469.
- Stanford, B.D., Weinberg, H.S., 2010. Evaluation of on-site wastewater treatment technology to remove estrogens, nonylphenols, and estrogenic activity from wastewater. *Environmental Science and Technology*. 44, 2994-3001.
- Suzuki, Y., Maruyama, T., 2006. Fate of natural estrogens in batch mixing experiments using municipal sewage and activated sludge. *Water Res.* 40, 1061-1069.
- Svenson, A., Allard, A., Ek, M., 2003. Removal of estrogenicity in Swedish municipal sewage treatment plants. *Water Res.* 37, 4433-4443.
- Takigami, H., Taniguchi, N., Matsuda, T., Yamada, M., Shimizu, Y., Matsui, S., 2000. The fate and behaviour of human estrogens in a night soil treatment process. *Water Science and Technology*. 42, 45-51.
- Ternes, T.A., Kreckel, P., Mueller, J., 1999a. Behaviour and occurrence of estrogens in municipal sewage treatment plants - II. Aerobic batch experiments with activated sludge. *Sci. Total Environ.* 225, 91-99.
- Ternes, T.A., Stumpf, M., Mueller, J., Haberer, K., Wilken, R.-., Servos, M., 1999b. Behavior and occurrence of estrogens in municipal sewage treatment plants - I. Investigations in Germany, Canada and Brazil. *Sci. Total Environ.* 225, 81-90.
- Ternes, T.A., Andersen, H., Gilberg, D., Bonerz, M., 2002. Determination of estrogens in sludge and sediments by liquid extraction and GC/MS/MS. *Anal. Chem.* 74, 3498-3504.
- Ternes, T.A., Herrmann, N., Bonerz, M., Knacker, T., Siegrist, H., Joss, A., 2004. A rapid method to measure the solid-water distribution coefficient (K_d) for pharmaceuticals and musk fragrances in sewage sludge. *Water Res.* 38, 4075-4084.
- Urase, T., Kikuta, T., 2005. Separate estimation of adsorption and degradation of pharmaceutical substances and estrogens in the activated sludge process. *Water Res.* 39, 1289-1300.

Vader, J.S., van Ginkel, C.G., Sperling, F.M.G.M., de Jong, J., de Boer, W., de Graaf, J.S., van, d.M., Stokman, P.G.W., 2000. Degradation of ethinyl estradiol by nitrifying activated sludge. *Chemosphere*. 41, 1239-1243.

Vanderford, B.J., Pearson, R.A., Rexing, D.J., Snyder, S.A., 2003. Analysis of Endocrine Disruptors, Pharmaceuticals, and Personal Care Products in Water Using Liquid Chromatography/Tandem Mass Spectrometry. *Anal. Chem.* 75, 6265-6274.

Yang, X., Shen, D., Fu, D., Li, G., Song, H., 2010. Optimization of solid phase extraction for determining steroid estrogens in wastewater by high-performance liquid chromatography. 1, 663-666.

Ying, G., Kookana, R.S., Kumar, A., 2008. Fate of estrogens and xenoestrogens in four sewage treatment plants with different technologies. *Environmental Toxicology and Chemistry*. 27, 87-94.

VITA

The Graduate College
University of Nevada, Las Vegas

Erica Marti

Home Address:

3930 Swenson Street Apt 802
Las Vegas, NV 89119

Degrees:

Bachelor of Science in Chemistry, 2004
University of Illinois at Urbana-Champaign

Master of Education in Curriculum and Instruction, 2007
University of Nevada, Las Vegas

Master of Science in Engineering, 2012
University of Nevada, Las Vegas

Thesis Title: Impact of Secondary Treatment Types and Sludge Handling Processes
on Estrogen Concentration in Wastewater Sludge

Thesis Examination Committee:

Chairperson, Dr. Jacimaria R. Batista, Ph.D.
Committee Member, Dr. David James, Ph.D.
Committee Member, Dr. Sajjad Ahmad, Ph.D.
Graduate College Representative, Dr. Spencer Steinberg, Ph.D.