

2017

Performance Evaluation of Virtual Flow Metering Models and Its Application to Metering Backup and Production Allocation

Kahila Mokhtari Jadid

Louisiana State University and Agricultural and Mechanical College, kmokht1@lsu.edu

Follow this and additional works at: https://digitalcommons.lsu.edu/gradschool_dissertations



Part of the [Petroleum Engineering Commons](#)

Recommended Citation

Mokhtari Jadid, Kahila, "Performance Evaluation of Virtual Flow Metering Models and Its Application to Metering Backup and Production Allocation" (2017). *LSU Doctoral Dissertations*. 4303.
https://digitalcommons.lsu.edu/gradschool_dissertations/4303

This Dissertation is brought to you for free and open access by the Graduate School at LSU Digital Commons. It has been accepted for inclusion in LSU Doctoral Dissertations by an authorized graduate school editor of LSU Digital Commons. For more information, please contact gradetd@lsu.edu.

PERFORMANCE EVALUATION OF VIRTUAL FLOW METERING MODELS AND ITS
APPLICATION TO METERING BACKUP AND PRODUCTION ALLOCATION

A Dissertation

Submitted to the Graduate Faculty of the
Louisiana State University and
Agricultural and Mechanical College
in partial fulfillment of the
requirements for the degree of
Doctor of Philosophy

in

The Department of Petroleum Engineering

by
Kahila Mokhtari Jadid
B.S., Urmia University, 2005
M.S., METU, 2011
May 2017

to my parents who were there to support me

ACKNOWLEDGEMENTS

I take great joy from acknowledging and giving thanks to my family, friends, and colleagues who provided for their support and assistance throughout this journey.

I am also thankful for each member of my faculty member committee. I am grateful for the guidance that I have received from my supervisor Dr. Paulo Waltrich for supporting me during these past four years. He has been helpful in providing advice many times during my graduate school career. He's one of the kindest and supportive people I know. I hope that I could be as enthusiastic, and energetic as Dr. Waltrich.

I am very thankful to Dr. Mayank Tyagi and Dr. Krishnaswamy Nandakumar for their support and help and especially for their useful comments as my committee members.

I would to thank Dr. Mileva Radonjic for her invitation that initiated my graduate studies at LSU. Also, I am thankful to Mr. George Ohrberg for providing technical support related to computer hardware and software. I would like to thank my partner Mr. Mirsardar Esmaeili for providing encouragement and study environment for me.

Funding received to complete my dissertation research came from Lettton Hall Group and Crafts and Hawkins Petroleum Engineering Department. This work would not have been possible without these financial supports in the form of graduate assistantships, respectively. I gratefully acknowledge field data provided by Petrobras.

I thank my parents and sister for their encouragement and support to pursue this journey. I am also grateful for my friends, who were supportive, especially when I felt discouraged.

TABLE OF CONTENTS

ACKNOWLEDGEMENTS	iii
LIST OF TABLES	vi
LIST OF FIGURES	vii
ABSTRACT.....	xi
CHAPTER 1: INTRODUCTION.....	1
1.1 Statement of the problem and motivation of this study.....	2
1.2 Objectives	4
CHAPTER 2: LITERATURE REVIEW	5
2.1 Test Separators.....	5
2.2 Multiphase flow metering (MPFM).....	7
2.3 Multiphase Flow Meters Categories and Types.....	9
2.3.1 Flowline meters	9
2.3.2 Separation type meters	16
2.3.3 Wet gas meters	18
2.4 Well Production Allocation Process	18
2.4.2 Unconventional Allocation Process	19
2.5 Virtual Flow metering (VFM)	20
2.6 Partial Conclusions from the Literature Review.....	26
CHAPTER 3: DESCRIPTION OF THE VFM APPROACH USED IN THIS STUDY	27
3.1 Network Model	27
3.2 Wellbore and Flowline Models.....	28
3.2.1 Enthalpy model	30
3.2.2 Multiphase flow models.....	30
3.3 Fluid Properties Model	31
3.4 Choke Model.....	31
3.4.1 Choke subcritical flow using the mechanics and API 14B models.....	32
3.4.2 Choke critical flow using the Mechanistic and API-14B models (PIPESIM 2013).....	33
CHAPTER 4: PERFORMANCE EVALUATION OF DIFFERENT VFM MODELS USING FIELD PRODUCTION DATA.....	34
4.1 Description of the field data collected for this study	34
4.2 Cases of Investigation	36
4.3 No-Tuning Case Results	37
4.3.1 Case 1 – Two points of GOR and Water cut.....	37
4.3.2 Case 2 – Productivity Index (PI), and two points of GOR and Water cut	48
4.3.3 Case 3 – Productivity Index (PI), all points of GOR, and two points of Water cut.....	54
4.4 Tuning Case Results	59

4.4.1	Case 4-Three points of oil and gas flow rates, all points of GOR and two points of water cut.....	60
4.4.2	Case 5-five points of oil and gas flow rates, all points of GOR and two points of water cut.....	69
4.4.3	Case 6- Five points of oil and gas rates, all points of GOR and five points of Water Cut.....	75
4.5	Comparison of five different VFM commercial packages	81
CHAPTER 5:	The VFM MODEL APPLIED TO METERING BACKUP	85
5.1	Results and Discussions.....	87
CHAPTER 6:	VFM MODEL APPLIED TO PRODUCTION ALLOCATION	89
6.3.1	Year one (Y1).....	92
6.3.2	Year two (Y2).....	96
CHAPTER 7:	CONCLUSIONS	98
REFERENCES	99
APPENDIX A:	FLUID PROPERTY CORREALTIONS FOR BLACK OIL MODEL.....	103
APPENDIX B:	RELATED SOFTWARE	106
VITA	107

LIST OF TABLES

Table 3.1	Choke Correlation Coefficients	32
Table 4.1	Fluid Properties	36
Table 4.2	Case 1 input data	38
Table 4.3	Reservoir Data	49
Table 4.4	Fluid Characteristic	49
Table 4.5	Case 3 input data	54
Table 4.6	Tuning case 1 input data.....	61
Table 4.7	Fluid properties tuned for case 4	65
Table 4.8	Tuning case 5 input data.....	69
Table 4.9	Fluid properties tuned for case 5	70
Table 4.10	Tuning case 6 input data.....	76
Table 4.11	Fluid properties tuned values for case 6	77
Table 4.12	Input data for five VFMs	81

LIST OF FIGURES

Figure 2.1	Production separator and test separator	7
Figure 2.2	MPFMs on the flow line of each well (Corneliusen 2005).....	8
Figure 2.3	Gamma ray attenuation (Hasan 2010)	10
Figure 2.4	The electrical impedance method of phase fraction measurement (Blaney 2008).....	11
Figure 2.5	Positive displacement flowmeter (Wildhaber 1966)	12
Figure 2.6	Venturi meter (Hasan 2010)	13
Figure 2.7	Ultrasonic flow meters (Al-Yarubi 2010)	14
Figure 2.8	Electromagnetic flow meters (Al-Yarubi 2010).....	15
Figure 2.9	Schematic diagram of a cross-correlation flow meter (Hasan 2010)	16
Figure 2.10	Separation type meters (Corneliusen 2005).....	17
Figure 2.11	Partial separation with two measurement loop (Corneliusen 2005)	17
Figure 2.12	A sketch of commingled flow (Sæten 2015).....	19
Figure 3.1	Schematic diagram for network model built for this study	28
Figure 4.1	Production data used in this study. Each selected point corresponds to the evaluation point used during the performance evaluations of the VFM models investigated in this study.....	35
Figure 4.2	Error percentage between predicted and measured wellhead pressures for different sets of choke correlations for all evaluation points.	41
Figure 4.3	Error percentage between predicted and measured wellhead temperatures for different sets of choke correlations for all evaluation points.....	42
Figure 4.4	Cumulative error percentage between predicted and measured wellhead pressures & temperatures for different sets of choke correlations for all evaluation points.....	42
Figure 4.5	Error percentage between predicted and measured gas flow rates for evaluation points A through O for case 1	43
Figure 4.6	Error percentage between predicted and measured oil flow rates for evaluation points A through O for case 1	44

Figure 4.7	Error percentage between predicted and measured water flow rates for evaluation points A through O for case 1	44
Figure 4.8	Error percentage for wellhead pressure matching for predicted oil and gas flow rates for case 1	45
Figure 4.9	Error percentage for wellhead temperature matching for predicted oil and gas flow rates for case 1	45
Figure 4.10	Schematic of well with IPR model included	48
Figure 4.11	Error percentage for predicted gas flow rates for evaluation points A through O for cases 1 & 2.....	50
Figure 4.12	Error percentage for predicted oil flow rates for evaluation points A through O for cases 1 & 2.....	51
Figure 4.13	Error percentage for predicted oil flow rates for evaluation points A through O for cases 1 & 2.....	51
Figure 4.14	Error percentage for wellhead pressure matching for predicted gas & oil flow rates for case 2.....	52
Figure 4.15	Error percentage for wellhead temperature matching for predicted gas & oil flow rates for case 2	52
Figure 4.16	Average error percentage for gas and oil flowrates for cases 1&2	53
Figure 4.17	Error percentage for predicted gas flow rates for evaluation points A through for cases 1,2,3.....	56
Figure 4.18	Error percentage for predicted oil flow rates for evaluation points A through O for cases 1,2,3.....	57
Figure 4.19	Error percentage for predicted water flow rates for evaluation points A through O for cases 1,2,3.....	57
Figure 4.20	Error percentage for wellhead pressure matching for predicted gas & oil flow rates for case 3.....	58
Figure 4.21	Error percentage for wellhead temperature matching for predicted gas & oil flow rates for case 3	58
Figure 4.22	Average error percentage for gas and oil flowrates for cases 1,2,3	59
Figure 4.23	Gas flow rate error percentage vs different choke correlations.....	63
Figure 4.24	Oil flow rate error percentage vs different choke correlation	63

Figure 4.25	Cumulative error percentage (points A+B+C) for gas and oil flow rates for different pair of choke correlations.....	64
Figure 4.26	Error percentage for predicted gas flow rates for evaluation points A through O for cases 1~4.....	66
Figure 4.27	Error percentage for predicted oil flow rates for evaluation points A through O for cases 1~4.....	66
Figure 4.28	Error percentage for predicted oil flowrates for evaluation points A through O for case 4	67
Figure 4.29	Error percentage for wellhead pressure matching for predicted gas & oil flow rates for case 4.....	67
Figure 4.30	Error percentage for wellhead temperature matching for predicted gas & oil flow rates for case 4	68
Figure 4.31	Average error percentage for gas and oil flowrates for cases 1~4	68
Figure 4.32	Gas flow rates error percentage vs different choke correlations for five points (A+B+C+G+H).....	71
Figure 4.33	Oil flow rates error percentage vs different choke correlations for five points (A+B+C+G+H).....	71
Figure 4.34	Cumulative error percentage for gas and oil flow rates vs different choke correlations for five points (A+B+C+G+H).....	72
Figure 4.35	Comparison of gas flow rates error percentage for cases 1~5.....	72
Figure 4.36	Comparison of oil flow rates error percentage for cases 1~5.....	73
Figure 4.37	Comparison of water flow rates error percentage for cases 1~5	73
Figure 4.38	Error percentage for wellhead pressure matching for predicted gas & oil flow rates for case 5.....	74
Figure 4.39	Error percentage for wellhead temperature matching for predicted gas & oil flow rates for case 5	74
Figure 4.40	Average error percentage for gas and oil flowrates for cases 1~5	75
Figure 4.41	Comparison of gas flow rates error percentage for cases 1~6.....	78
Figure 4.42	Comparison of oil flow rates error percentage for cases 1~6.....	78
Figure 4.43	Comparison of water flow rates error percentage for cases 1~6	79

Figure 4.44	Error percentage for wellhead pressure matching for predicted gas & oil flow rates for case 6.....	79
Figure 4.45	Error percentage for wellhead temperature matching for predicted gas & oil flow rates for case 6	80
Figure 4.46	Average error percentage for gas & oil flow rates for all cases	80
Figure 4.47	Comparison of gas flow rates of five different commercial VFM software	83
Figure 4.48	Comparison of oil flow rates of five different commercial VFM software	83
Figure 4.49	Average error percentage of oil and gas flow rates of five different commercial VFM software.....	84
Figure 5.1	Error percentage for predicted water flow rates for evaluation points A through O for all cases.....	88
Figure 5.2	Average flow rates error percentage for all six cases.....	88
Figure 6.1	Schematic of two wells commingled to the same platform.....	90
Figure 6.2	Workflow diagram showing the basic steps on the calibration process of the VFM model using well test data.....	91
Figure 6.3	Well # A estimated flow rates by the well test & the flow model for the year one	94
Figure 6.4	Well # B estimated flow rates by the well test & the flow model for the year one	94
Figure 6.5	Well # A flow rate relative error % for the year one.....	95
Figure 6.6	Well # B flow rate relative error % for the year one	95
Figure 6.7	Well # A estimated flow rates by the well test & the flow model for the year two	96
Figure 6.8	Well # B estimated flow rates by the well test & the flow model for the year two	97
Figure 6.9	Well # B flow rate relative error % for the year two.....	97

ABSTRACT

In the oil and gas industry, reliable and accurate measurements of the amount of oil, gas and water being produced by individual wells is essential. The production revenue for each well is determined from measured flow rates. Measurement of well production can be achieved by using multiphase flow meters on individual wells. However, the use of such metering technique is not always reliable or economical. As an alternative technique to monitoring individual well performance in real-time, multiphase flow simulators together with pressure and temperature sensors located at different locations in the production systems have been recently deployed to estimate individual well flow rates. In the oil and gas industry, this technique has been called Virtual Flow Metering (VFM).

In this study, the implementation and performance of commercially available multiphase flow simulators are evaluated using actual field production data. Field measurements from sensors are used which have been installed in various points of the production system such as in the wellbore bottomhole and wellhead are used. This study is consisted of two parts: i) evaluation of the performance of virtual flow meters (flow models) with actual field data, and ii) evaluate the performance of VFM in different application scenarios such as flow metering backup and well production allocation. The model results are compared to actual flow rates to evaluate the effect of using different number of measuring points of pressure, temperature, and the effect of fluid properties.

Although, the VFMs are easy to install, cheap and have low-cost maintenance, they have not been accepted as a replacement to MPFMs so far. This study will also investigate the combination of VFMs and MPFMs as a potential solution for the common problem of MPFMs malfunction and need of frequent calibration due flow assurance problems (such as scale deposition, and significant variations in multiphase flow behavior).

CHAPTER 1: INTRODUCTION

The production rates from individual wells are used to access the productivity of each well, provide information about forecast production decline and excessive water production. Prior to the 1980s, single-phase measurements were used in the industry. At that time, the flow rates from different wells commingling to the same production separator have been measured as total flow rates, without the knowledge of individual well flow rates. These separators are able to separate the oil, gas and water phases. The outputs of the separated fluids are measured by conventional single-phase techniques, such as orifice plates for gas phase and turbine meters for oil and water phases(Corneliussen 2005).

In the early 1980s, the oil and gas industry started to gain interest in developing Multiphase Flow Meters (MPFMs). MPFMs are able to measure the flow rates of oil, gas and water from each well and also from group of wells without separation of the phases. However, the installation and maintenance of such MPFMs are usually expensive and time consuming. For instance, MPFM are often installed in subsea production system. In case of metering failure, the access to calibrate or verification of MPFM is very difficult on subsea systems. Therefore, development of techniques that can help on identifying metering failure is essential (Jenson 1992).

One of the techniques that has started to gain some momentum in the last decade on indicating MPFM malfunction is the so-called Virtual Flow Meters – or VFM. VFMs are commercially available flow modeling software, which can be used as a backup or alternative for multiphase flowmeter devices. The VFM models are easy to use and also need low cost maintenance. This is the greatest advantage of using VFM models. VFM models use only mathematical models and pressure and temperature measurement points from sensors that are already installed in each well for production operation and monitoring (Toskey 2012, Corneliussen 2005).

Recommended practices such as the API RP 86, 2005 have recently acknowledged the fact that the use of VFM models as an effective alternative for multiphase flow rate measurements, particularly in subsea systems when multiple wells are commingled to the same production separator ((API) 2005, Corneliussen 2005). However, the acceptance of VFM models for flow rate determination is still limited by regulatory agencies. This limited acceptance is likely due to the fact that there is still a scarce number of studies in the literature about VMF models description, validation and field experiences ((API) 2005). From few studies available in the literature that validate evaluate VFM models with field data it is possible to see that this technique has shown promising results in the field for flow rate determination, with accuracy levels similar to actual flow meters (Haldipur et al. 2008, Melbø et al. 2003). Nevertheless, more studies are still needed in more details to evaluate the VFM models performance in a wider range of conditions to assess its weakness.

1.1 Statement of the problem and motivation of this study

There are still many challenges related to flow rate measurements with multiphase flow meters and test separators. When using separator-based methods, obtaining reliable measurements from test separators require relatively stable conditions, which can demand significant amount of time, particularly for offshore-deepwater wells with long flowlines ((API) 2005). MPFMs which are capable of measuring the flow rate of each phase directly on individual wellheads potentially solves most of these issues, which can measure flow rates in real-time and without the need of stable conditions. However, these type of meters have also some limitations such as:

1. MPFMs are expensive and require frequent calibration and long-term maintenance. MPFMs are still not widely used in the field due to high cost of installation, repair and replacement.
2. At high Gas-Volume-Fraction (GVF) and Water-Liquid-Ratios (WLR), uncertainty in oil rates increases (Falcone, 2009). The majority of MPFMs show larger errors for GVF > 90%.
3. If the presence of wax, scale, or asphaltene deposition is likely, the accuracy of MPFMs can be highly affected.

In the field, high levels of GVF, WLR and deposition of wax or asphaltene can be difficult to predict accurately. Therefore, a proper backup system should be available if the multiphase flow meters fail (Corneliusson 2005).

In the last decade, researches started using Virtual Flow Metering as a potential solution to the metering backup problem (Dellarole et al. 2005, Haldipur and Metcalf 2008). VFM method uses conventional sensors (e.g. pressure and temperature sensors) to estimate flow rates. The pressure drop over choke valves and over a section of pipe can be used to estimate flow rates (Gioia Falcone 2009). VFM models can also estimate the well production rates in real-time. VFM models can provide real-time information on flow rates for the different phases, liquid holdup, pressure and temperature profiles, and proximity to hydrate formation or wax deposition. This information allows better understanding of changes to well performance and assists production optimization and reservoir management. A VFM model may consist of a single well to an entire field of co-mingled wells. In addition, VFM models are easy to install, operate and maintain (Mokhtari et al. 2016).

Another area where the use of VFM models is becoming popular is on well production allocation. Conventionally, production allocation of multiple wells comingling to one production separator consists of shutting all wells but the one to be tested, in order to obtain flow rates of individual wells. Conventional production allocation testing is time consuming and expensive, as it includes loss of production for several hours while carrying out the well tests. In order to avoid many days of loss in production, well tests are not executed very often, usually with a time interval of one month between well tests. However, oil, gas or water production of individual wells may vary significantly between well tests, and consequently, the accuracy of well-test based production allocation can be highly affected. VFM models can offer a solution to this problem, while monitoring the well performance and reservoir management (Varyan et al. 2015).

1.2 Objectives

This study includes two main objectives: i) evaluate different VFM systems over a range of multiphase flow conditions using field data, ii) evaluate the use of VFM models as metering backup and for production allocation process.

There is still a gap of studies comparing different VFM models/correlation to identify the effect on VFM accuracy when using different models/correlations. The objectives are composed to address basic questions by making a comparison between different VFM flow models and reference field data. These basic questions try to address recommendations given by recommended practices on the use of VFM models ((API) 2005, Corneliussen 2005), which have not been clearly discussed or investigated systematically in the recent literature. The basic questions that will be aimed to be answered in this study are the following (Toskey 2012):

- Do flow rate predictions improve with additional pressure and temperature measurement points along the flow path?

- Are some measurement points (sensor data) more significant than others, such as temperature versus pressure?
- Are there a minimum number of sensors required for a reasonable VFM performance?
- Are VFMs capable of detection the erroneous of input data?
- Are VFMs capable of detecting the inaccuracy in the allocation rates?
- Does VFM model have sufficient accuracy that can replaced or improve well test results for allocation process (Toskey 2012)?

Answering these questions with recent VFM model results will guide the industry on how to efficiently use VFM models for multiphase flow metering, metering backup, and production allocation. The latest recommend practices on multiphase flow measurements have not being update in the last decade ((API) 2005, Corneliussen 2005), while VFM models have significantly improved its accuracy in the last 10 years. The VFM results analyzed in this study will be used to draw conclusions about the VFM state-of-the-art technology and not focus on recommending the advantages of any particular commercial software ((API) 2005).

CHAPTER 2: LITERATURE REVIEW

2.1 Test Separators

Prior to 1980s, a test separator was used to separate or meter the well fluids. Test separators can be used for both two- and three-phases, and they also are applicable for both onshore and offshore well testing. Ideally, a traditional method of flow analysis relies on routine periodic production testing through a separator. In early 1980s, multiphase flow meters have been developed. A multiphase meter could eliminate the need for a test separator; as the test separators are large and difficult to maintain, and may require long stabilization time to obtain steady well flow rates (Jenson 1992).

A new Multiphase Flow Meter (MPFM) installation can save space and cost in comparison to the installation of a new test separator. These separators are expensive and require long periods of time to monitor each wells performance because of the time required to reach stabilized flow conditions. In well testing applications, an extra test separator is used for well tests where one well stream is directed through the test separator (Figure 2.1). The well rates is then separated into three "phases"; which are measured by using single-phase meters at the outlets of the separator. Single-phase meters include orifice plates for gas phase and turbine meters for oil and water phases (Corneliussen 2005).

Multiphase flow meter can be used as a replacement for test separator, because the MPFM responds more quickly to changes in the well performance than the test separator. Therefore, more well tests may be carried out since the response time of the MPFM is less than a test separator. This issue is particularly important in deepwater developments. The use of MPFMs for well-testing provides satisfactory measurements without separation of the phases (Falcone et al. 2001).

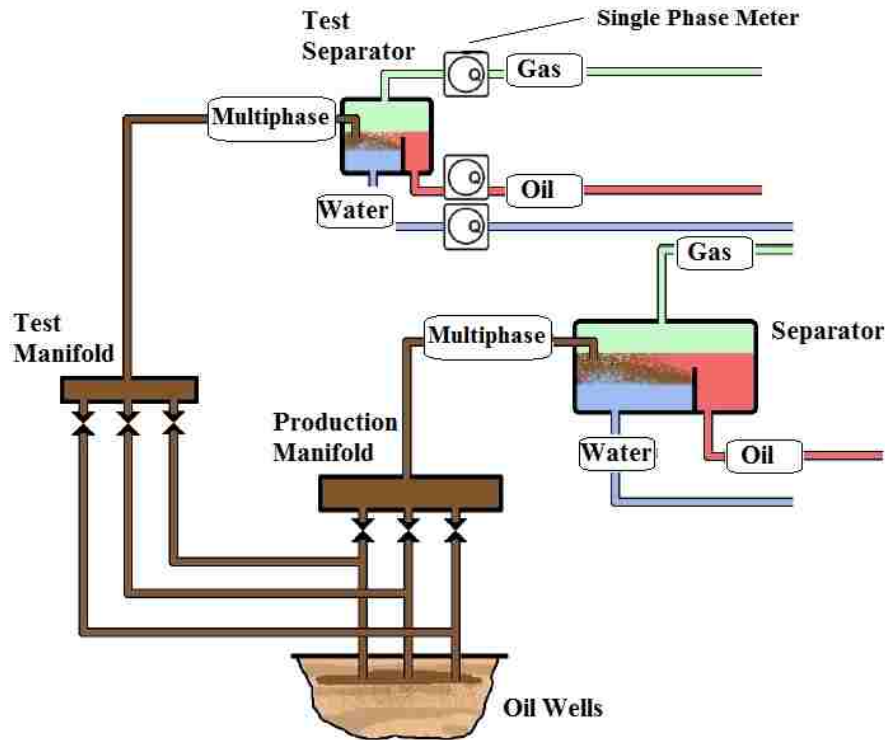

Figure 2.1 Production separator and test separator

2.2 Multiphase flow metering (MPFM)

MPFM is the measurement of the flow rate of each individual phase in a multiphase flow (Figure 2.2). The wording Multiphase Flow Metering (MPFM) started to appear well after the establishment of separators for industrial applications. MPFMs were first conceived by metering of the simultaneous flow of two or more phases, without the need for separation. These physical meters could measure more complex flows better than single-phase test separator. However, if both MPFM and test separator are installed in same time, they could increase the flexibility for a production well. In the oil and gas industry, MPFMs can lead to greater benefits over the test separators in terms of production monitoring, layout of production facilities and well testing (Kuchpil et al. 2003).

Li et al. (2004) described the characteristic of the MPFM based on a turbine type flow meter using a number of liquids with different viscosities. The MPFM outputs and reference data are compared and the average percent error was 10%. The MPFM results are evaluated against the test separator at field test for a one year and showed the following results:

- Gas Flow rate: 9.7% of absolute relative error
- Liquid Flow rate: 2.6% of absolute relative error

The MPFM technology is complex and it still has some considerable limitations. For high gas-liquid-ratios and water-liquid-ratios, the uncertainty for MPFM is significantly higher. These meters can also fail, which the repairing and calibration is time consuming and may cause considerable loss in production. There are several types of MPFMs available in the market. Therefore, optimal selection of these meters is an important factor. For instance, having a reasonable knowledge about the multiphase flow regimes of a well, helps to use on the appropriate selection of a MPFM for a specific well (Corneliusson 2005).

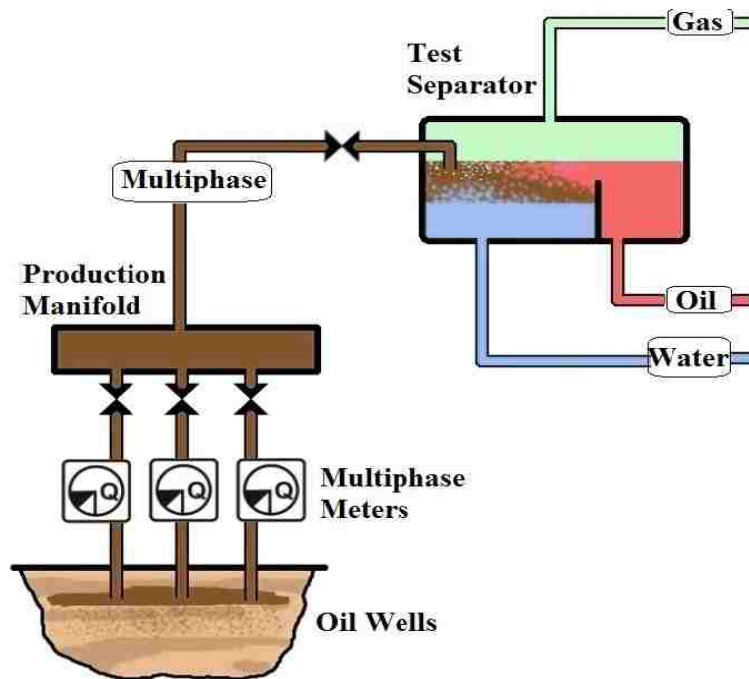

Figure 2.2 MPFMs on the flow line of each well (Corneliusson 2005)

2.3 Multiphase Flow Meters Categories and Types

Multiphase flow meters can be divided into three main categories:

1. Flowline meters
2. Separation type meters
3. Wet gas meters

2.3.1 Flowline meters

In-line multiphase flow meters are directly installed in multiphase flow lines and individual phase flow rates or total flow rates can be measured directly without separation of the well stream. These meters use a mixed of two or more measurement technologies. Common measurement principles are measuring the phase fraction, phase velocity and phase density in MPFMs system such as (Hasan 2010):

- Phase volume fraction measurement:
 - Gamma ray attenuation
 - Electrical impedance methods (capacitance and conductance)
- Phase velocity fraction:
 - Positive displacement using reciprocating piston
 - Differential pressure technology using Venturi meter
 - Velocity measurement using turbine, ultrasonic meters
 - Electromagnetic measurement principles
 - Cross correlation

2.3.1.1 Gamma ray attenuation

This technique measures the average liquid and gas volume fraction of two-phase flows. Gamma rays are used in the technique which different materials absorbed different gamma rays based on different rates. Figure 2.3 shows a gamma-ray densitometer that is made of two main parts; a radioactive source and a detector. The volume fraction of the fluids can be measured when the beam of Gamma rays pass through the fluids. Figure 2.3 shows a beam of Gamma ray that passes through two phases of liquid and gas where the gas and liquid phases are perpendicular to the radiation beam. Basically, A beam of gamma rays is attenuated by absorption and scattering and the absorbed or scattered amount of the radiation is a function of the energy level and density. (Blaney 2008).

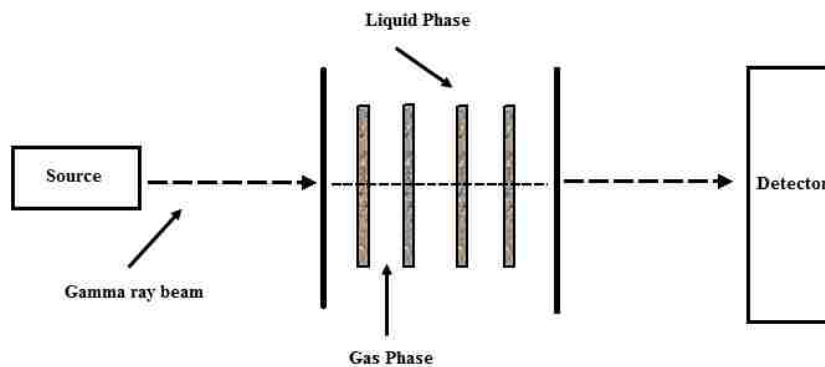

Figure 2.3 Gamma ray attenuation (Hasan 2010)

2.3.1.2 Electrical impedance methods (capacitance and conductance)

Electrical impedance methods include multiphase flow through a section of pipe with an electrical conductor. Figures 2.4 shows the principle of the electrical impedance method of phase concentration measurement. The electrical impedance (Z_e), is measured between two electrodes where oil, gas, water mixture is flowing. The measurements that are obtained from these devices are based on the variation of the conductance or the capacitance (permittivity) of the two-phase flow. The contacting or non-contacting electrodes are engaged to measure the electrical impedance

of the multiphase flow, thus, the conductance or the resistance (R_m) and the capacitance (C_m) of the fluid can be determined (Al-Yarubi 2010, Ceccio et al. 1996). The electrical impedance methods work by characterizing the multiphase fluid flowing through a section of pipe as an electrical conductor. Equations 2.1 and 2.2 show that the measured capacitance (C_e) and resistance (R_e) depend on C_m and R_m , the excitation frequency of the detection electronics ω and the capacitance of the pipe wall C_p (Thorn et al. 2012),

$$R_e = \frac{1 + \omega^2 R_m^2 (C_m + C_p)^2}{\omega^2 R_m C_p^2} \quad (2.1)$$

$$C_e = \frac{[1 + \omega^2 R_m^2 C_m (C_m + C_p)] C_p}{1 + \omega^2 R_m^2 (C_m + C_p)^2} \quad (2.2)$$

The measured capacitance (C_e) and resistance (R_e) are a direct function of the component ration of the mixture if the excitation frequency of the detection electronics, fluid properties and flow regimes are constant.

When the water-cut is more than 60%, the capacitance method should be replaced by conductivity methods, as the fluid changes from oil to water stream. Usually, the conductivity can be measured by injecting a controlled electrical current into the flow, and then the voltage can be measured between the electrodes (Al-Yarubi 2010).

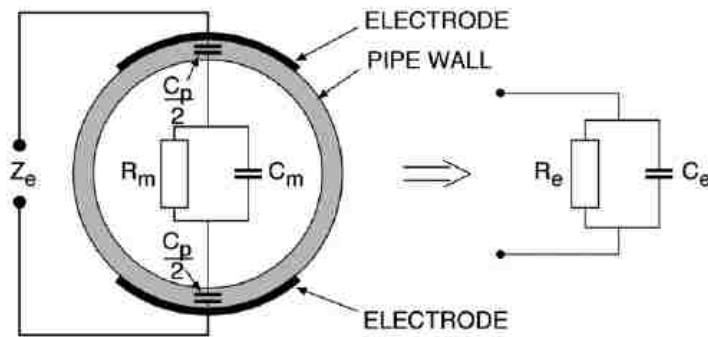

Figure 2.4 The electrical impedance method of phase fraction measurement (Blaney 2008)

2.3.1.3 Positive displacement flow meter

The meter consists of a number of chambers which are charged and discharged with the fluid continuously. The flow is divided into separate volume packets. These packets are added to obtain the total volume flow by measuring the unit volumes passing through the meter. A positive displacement device separate the fluids into liquid and gas phases by using a reciprocating piston, oval gear, and rotary vane. In MPFM applications, the meter generally could measure the total volumetric flow rates (Hasan 2010). As it is shown in figure 2.5, the piston gliding direction part is the section that the piston glides around the control roller like a hula hoop spins around the hooper in a circular motion.

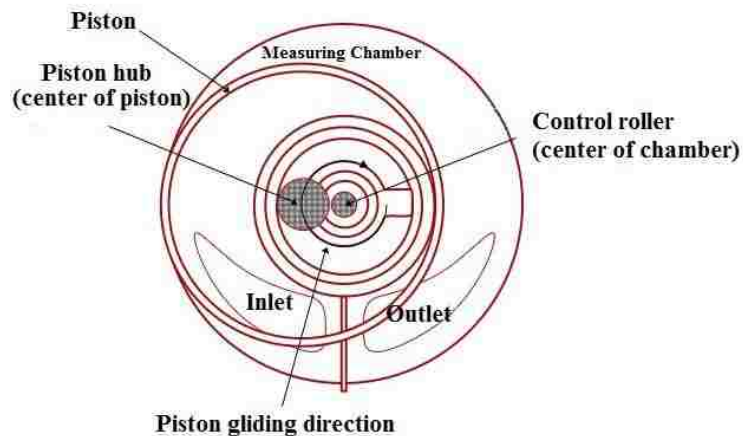

Figure 2.5 Positive displacement flowmeter (Wildhaber 1966)

2.3.1.4 Venturi flow meter

Differential pressure across the upstream and downstream of a restricted section of the device is measured by installing a Venturi meter. A Venturi meter use a pipe converging section to increase the flow velocity and a corresponding pressure drop from which the flowrate can be deduced. This type of flow measurement instruments basically determines the velocity of the multiphase flow. As it is shown in figure 2.6, P_1 and P_2 are high pressure connection and low

pressure connection respectively. D_1 and D_2 are the diameter of inlet and the diameter of throat respectively. Differential pressure devices can be used in orifice plates and nozzles as well (Corneliussen 2005).

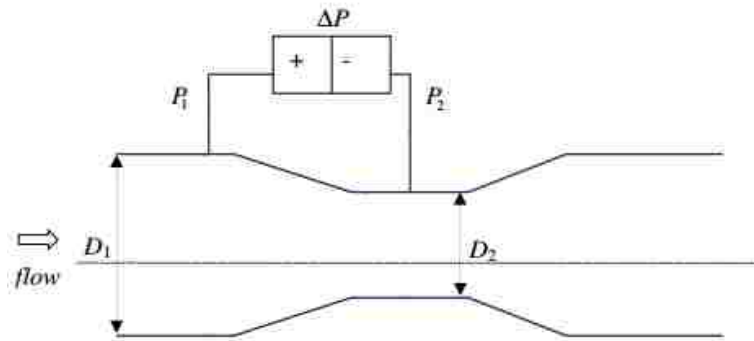

Figure 2.6 Venturi meter (Hasan 2010)

2.3.1.5 Ultrasonic flow meter

The ultrasonic meters measure the average velocity in the multiphase flow system. They rely on an ultrasonic signal that is affected and changed by the velocity stream. Ultrasonic transducers are used which measure the average velocity along the path of an emitted beam of ultrasound. Essentially the velocity can be measured by averaging the difference in measured transit time between the pulses of ultrasound propagating into and against the direction of the flow as it is shown in figure 2.7.

These meters are built in several types: i) transducers are installed in series with the flowline system, or ii) the meter is strap-on the outside of the pipeline system stream, allowing non-intrusive flow measurements (Al-Yarubi 2010).

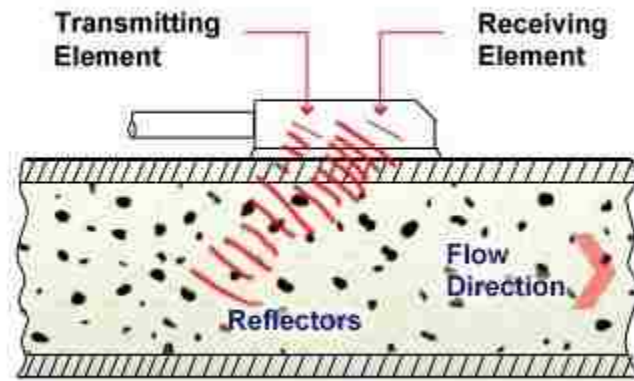

Figure 2.7 Ultrasonic flow meters (Al-Yarubi 2010)

2.3.1.6 Electromagnetic flow meter

Electromagnetic flow meters are easy to install and can be easily turned into meters by adding external electrodes and suitable magnets. They are non-invasive measurements and insensitive to viscosity, density, and flow disturbances as well. The Faraday's law of electromagnetic induction is the principle of the electromagnetic flow meter. In an electromagnetic flow meter, the voltage induced across any conductor as it moves at right angles through a magnetic field is proportional to the velocity of that conductor. Electromagnetic flow meters cannot measure gas phase (Al-Yarubi 2010).

E is proportional to $V \times B \times D$ where:

E = The voltage generated in a conductor

V = The velocity of the conductor

B = The magnetic field strength

D = The length of the conductor

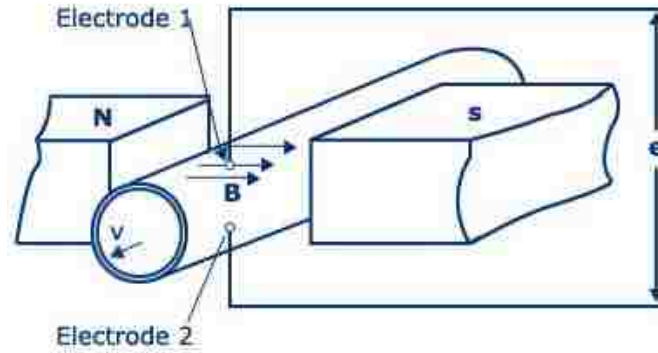

Figure 2.8 Electromagnetic flow meters (Al-Yarubi 2010)

2.3.1.7 Cross correlation flow meter

The cross correlation technique can be used to measure the velocity of the fluids in a pipe. In this meter, some properties of the flow are measured by two similar sensors at two different locations with a known distance between the meters. When the flow passes between the two sensors, the output signal pattern from the first sensor will be repeated at the second sensor after a short period of time. The time lag between two sensors matches the time taken for discontinuities in the flow to travel between the sensors. The velocity of the flow can be calculated if the distance between the sensors is known (Munir et al. 2013).

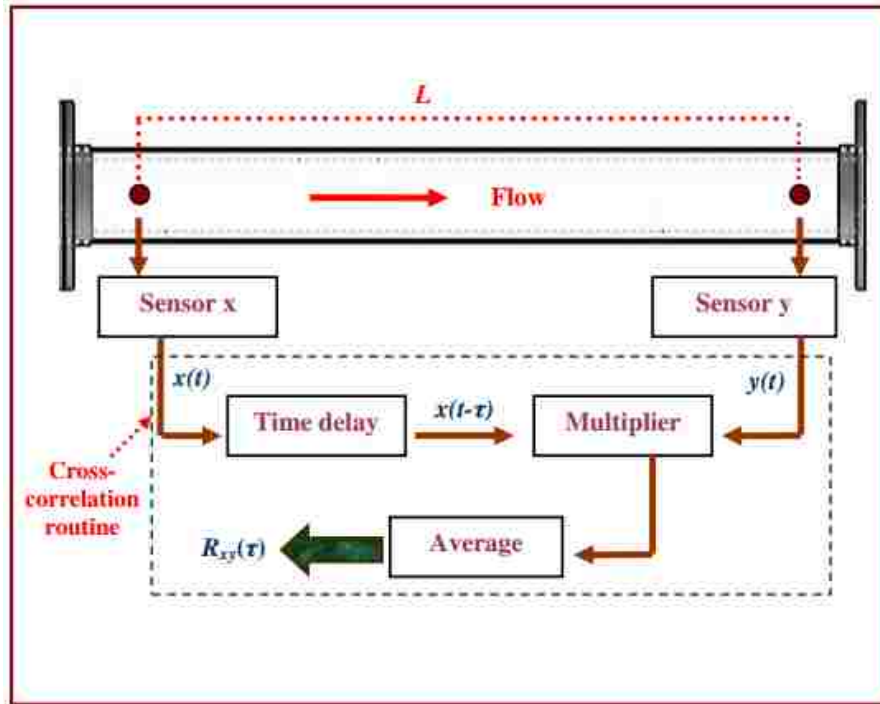

Figure 2.9 Schematic diagram of a cross-correlation flow meter (Hasan 2010)

2.3.2 Separation type meters

These separation meters are a class of MPFMs which can be define in two categories of two-phase gas-liquid separation and partial separation. In two-phase gas-liquid separation, a complete separation between gas and liquid occurs. Then, the gas and liquid flow is measured using a single-phase gas and single-phase liquid flow meter (Corneliussen 2005). The water-liquid-ratio can be determined by installing an on-line water fraction meter as it is shown in Figure 2.11.

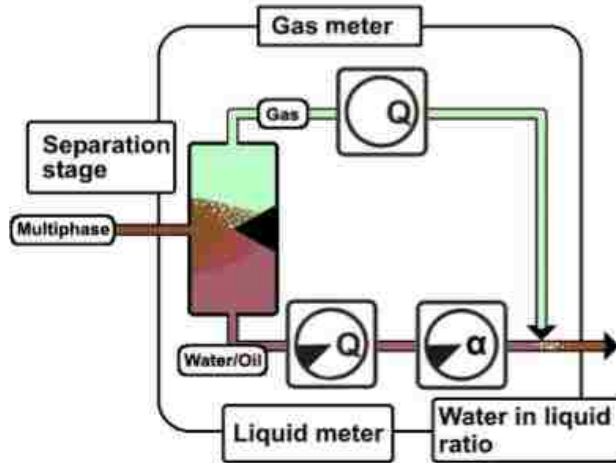

Figure 2.10 Separation type meters (Corneliusson 2005)

The partial separation segment of the flow meter separates part of the gas from the multiphase flow stream using a measurement loop around the main loop through multiphase flow meter. Since the separation is partial, some liquid might mix with gas through the measurement loop (Corneliusson 2005). Therefore, it can be named wet gas measurement as it is presented in Figure 2.12.

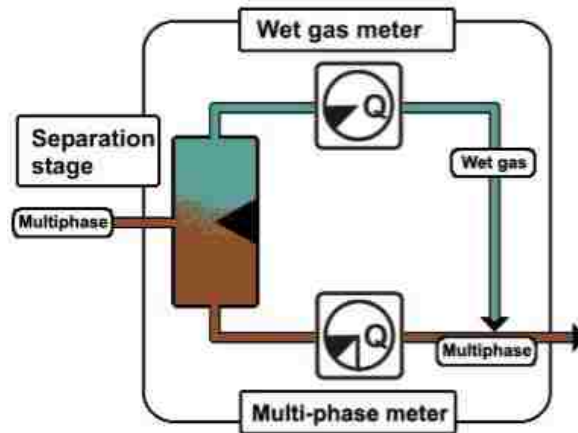

Figure 2.11 Partial separation with two measurement loop (Corneliusson 2005)

2.3.3 Wet gas meters

Wet gas meters can be installed in wet gas application alone or it can be installed in combination of various measurement techniques. There are some types of applications for this meter such as:

- The entrained liquid into gas flow measurement. A single phase meter is used to correct for the liquid fraction. The purpose is to obtain the correct gas measurement and solve the entrained liquid problem.
- The hydrocarbon gas and liquid measurement which the liquid should be measured as well.
- The hydrocarbon gas, hydrocarbon liquid and water measurement which the hydrocarbon should be measured.
- Changes in water salinity measurement which the objective is to monitor well for the water breakthrough situation (Corneliussen 2005).

2.4 Well Production Allocation Process

Allocation is the process for obtaining the individual well flow rates by using different measurement points. The measurement equipment consist of pressure and temperature gauges at wellbore downhole, upstream and downstream of the production chokes gauges, multiphase flow meters (MPFM), and test separators. Figure 2.13 shows the sketch that production from multiple wells are gathered at the manifold, and transported as a commingled flow.

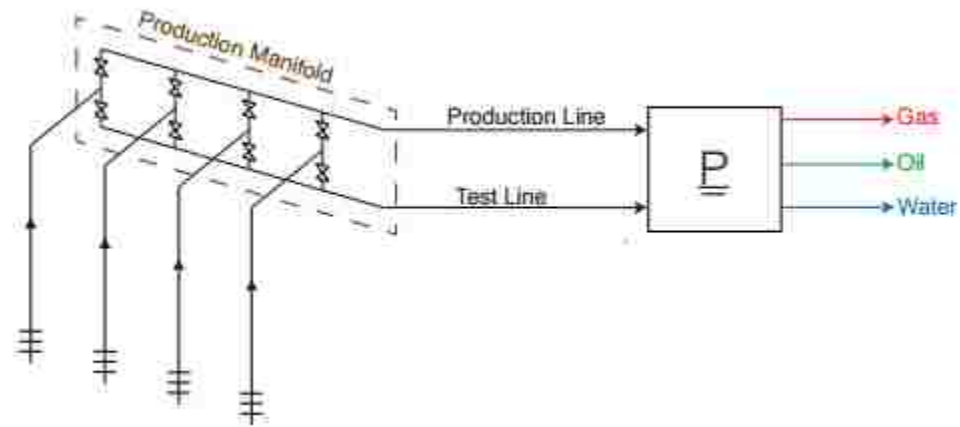

Figure 2.12 A sketch of commingled flow (Sæten 2015)

Well surveillance especially in real-time is becoming a significant part of the petroleum production business and many of the production parameters are monitored in this process to optimize production (Abdel Rasoul et al. 2011). It is very important to allocate the flow rate for each layer that are producing from multilayer zones. In addition, it is also essential to allocate the production rates for the individual wells that are commingled to same production separator. The accurate production allocation will lead to effective reservoir and wellbore production management. while poor allocation will impact the accuracy of reservoir modeling and material balance calculations. As an example, in a heterogeneous reservoir with large variation in fluid properties, each well in this reservoir will be behave differently (Sæten 2015).

2.4.2 Unconventional Allocation Process

Conventional well testing is essentially performed by using an extra separator that is installed for well test. Conventional allocations use well test rates to allocate the production rates of the wells. The allocated rate or the individual well rates can be measured by directing one well flow rates through the test separator at the time. The well flow rates are then separated and measured into three phases by conventional single-phase meters. The flow rates of the well are not updated until the next well test, which are often performed one month later. Some parameters such

as wellhead pressure, choke opening, separator pressure and temperature are also measured during a well test. These parameters are used until the next well test to measure the well stream. Multiphase flow meters can be installed and used individually and in addition to an existing test separator. The important advantage of multiphase flow meters over the test separator is that MPFMs need less time to stabilize and more stable to changes in the well fluids.

The unconventional allocation schemes are those which utilize a flow model. Mathematical based models are used to build the flow model (Virtual flow meter systems) which help to predict the production of each well or inlet separator at the sales point. The flow models require actual operating conditions such as pressures, temperatures, compositions and measured production. Traditionally, allocation process can be performed monthly by the well test which can be less accurate than the daily allocation based on continuous well flow estimates.

Testing an individual well continuously is not economically feasible. For such continuous measurements, it would require the installation of a dedicated test separator or multiphase meter for each well, which would this approach uneconomical.

2.5 Virtual Flow metering (VFM)

It is essential to production and reservoir engineers to determine how much the wells are producing for effective production optimization and reservoir management. Basically, this could be attained by using MPFMs, which can provide flow rate measurement continuously for the wells. However, it may not be possible to install MPFMs for all wells due to high costs and difficult access for maintenance, calibration or replacement in case of malfunction. A real-time software application often called Virtual Flow Meter could provide a continuous determination of oil, gas, water flow rates for all wells. These software are built based on the hydraulic models from the reservoir to the surface facilities (Falcone, 2009).

Melbø et al. (2003) demonstrated the ABB Well Monitoring System (WMS) which is a software system for estimating flow rates from the wells in oil production networks. The concept is suitable also for sparsely instrumented production facilities. The software has some capabilities. It reduces the need for well testing, and it can be monitored and maintained from remote locations. In addition, it has been shown how low quality measurements can be used for rate estimation, and how the software can be calibrated without performing single-well tests. They have indicated that promising results (about 16% between measured and estimated flow rates) are obtained while there is still no available information about the choke valve, the bottomhole sensors failed, and the temperature measurements were influenced by sea water temperature.

McCracken et al. (2006) presented two field case studies. In both cases, a pressure based rate allocation method is used. In this method, based on pressure transient analysis, simple reservoir models are built. Based on the pressure transient analysis, the rates are predicted based on the measured downhole pressures and the developed model. In one case study, production from stacked reservoirs is commingled into smart well and in the other case, wells that are producing from several reservoirs are commingled to production at a subsea template. Two case studies are carried out and the flow rates showed consistent results with the downhole pressures, and the number of well tests that are usually performed for allocation purposes are decreased significantly.

Leskens et al. (2008) defined multiphase soft-sensors (modeling based) system as an alternative to overcome the disadvantages of the multiphase flow meters. The latter author demonstrated two case studies based on simulations. In the first case, only pressure and temperature measurements are used to predict the real-time flowrates of the different phases. In the second case study, the allocating of the inflow of specific fluids along the wellbore with multiple flow zones is evaluated. As a result, in the first case; the flow rate estimation via

simulation is possible, if the data that are achieved from measurements are not noisy and complex. However, when the pressure and temperature measurements are noisy, the prediction of flow rates by the simulation is not possible. In the second case study, the prediction of multiphase flow rates is possible by using downhole-pressure measurements in addition to single-phase flow meters.

Haldipur and Metcalf (2008) used field data to evaluate the performance of VFM technique. They showed that virtual flow metering technology has provided accurate and reliable flow rate estimation of wells (about 8% error between measured and estimated rates) over a variety of reservoir characteristics, ranging from black-oil to gas-condensate systems, including a wide range of gas-liquid-ratios and gas-oil-ratios. These authors have described a virtual metering system that uses bottomhole pressure and temperature in addition to upstream and downstream choke pressure and temperature with choke positions. Some examples are also indicated in this study. The developed virtual metering system has been used for scale buildup and leak detection.

(Ibrahim 2008) developed a VBA code by using a PVT model, an inflow performance model, a wellhead allocation module and flow test data points. A combination of multirate tests and downhole pressure measurements are used to build the accurate inflow performance relationship for the individual wells. The relationship between wellhead flowing pressure and flow rate is programmed at each reservoir pressure. The allocation program is tested with actual field data for at least two years. An accurate daily production allocation is obtained based on multirate tests and modeling with 5% allocation error.

Muradov et al. (2009) presented a method of zonal rate allocation by using the measured pressure and temperature data. In addition to a set of mathematical optimization algorithms, the inverse problem is solved by comparing and matching the estimated pressure and temperature data with the values that are measured with limited accuracy. Based on the algorithms that used in this

study, the extended Kalman filter and numerical optimization algorithms can show satisfactory results with the error percentage less than 20%.

(Loseto et al. 2010) presented that the continuous monitoring of production of the wells using multiphase flow meters on individual well frequently is not economically feasible. Several real-time VFM estimation methods can be implemented using existing surface and sub-surface measured variables. These methods are used as a backup to provide continuous flow rate surveillance and obtain Best Real-Time Estimation (BRTEs) at well level. BRTEs can be added to provide Aggregated Real-Time Estimation (ARTEs). In conclusion, VFM in the form of BRTE and also ARTE have showed to be important for multiphase flow meter validations and to support field and reservoir management, including allocation for individual wells.

(Heddle et al. 2012) described the BP Rate & Phase software system. The system could predict the production from the individual wells. This pressure and temperatures sensors are installed on new wells. The BP Rate & Phase VFM has been implemented on a number of wells located in the North Sea, Gulf of Mexico and Angola. Different physical models consist of inflow performance and choke valve performance models are used to predict the production of the wells. The Rate & Phase VFM is able to automatically reconcile production across the entire fields, and sand production and estimate reservoir pressure at shut-in wells. The technology has indicated that, it is possible to create a VFM model which is capable of estimation the flow rate of each well in a field for a few times per hour. Finally, this VFM has the capability to apply for a wide range of well types, fluid conditions and operating conditions. The VFM model showed an error percentage less than 10% between the measured and the estimated flow rates.

Haouche et al. (2012) described a new method to show that how ESP model could be performed in VFM. He analyzed the impact of the gas on the ESP performances. The results that

are obtained from VFM model, has confirmed the potential of the DVR (Data Validation & Reconciliation) to be used as an online production metering and monitoring system. A correction is proposed to model the pump properly. It is called the density correction which is used to cover correctly the multiphase flow conditions at the pumps inlet. A comparison study is carried out between the current ESP model and the model based on the density correction method. The study showed the sensitivity of the ESP to the multiphase conditions at the inlet.

Cramer et al. (2012) described FieldWare Production Universe (PU) real time well virtual flow measurement (VFM) tool. This tool has been applied to about 60% of Shell's global production. In fact, this tool applied in the start-up of a number of Shell's offshore projects in the Persian Gulf and the Gulf of Mexico. PU VFM worked effectively for both the steady state and the well transient operations. The results showed that the error percentage between the measured and estimated rates are about 10%. Subsequently, the flow rates of the well are estimated during the initial start-up which showed effective well surveillance, early indications of well/reservoir flow performance.

Udofia et al. (2012) described the production universe (PU), which is an allocation and production monitoring tool developed by Shell. He demonstrated that by using PU, reasonable production reconciliation factor could be obtained even with significant changes in pressure support. Actually, there was 9% difference in the fraction of cumulative production between the allocation processes. The flow models are created in the Production universe (VFM) by using the test points. These models can work as multiphase meters and make correlation between the allocated rates and well measurement.

Wu et al. (2012) described a framework on how to get the real time data from pressure and temperature sensors and implement them in flow models to allocate the well rates. They used Atlantis oil field in Gulf of Mexico to demonstrate the allocation process. The real time data are used in flow model based allocation process. The allocation rate accuracy based on traditional well test (allocation method) is improved from +/- 10% error to +/- 3% error using the new flow model. Using real time data and pressure temperature sensor data, make it easier to capture well transient behavior and increase the accuracy of the allocated rate.

Al-Kadem et al. (2014) described experiences with multiphase flow meters for a decade in northern fields of Saudi Aramco. 168 MPFMs are operated by various vendors in different environment during the past ten years. Based on the analysis, the MPFMs mean time between failure and repair showed that, the MPFMs are available 97% of the time. Monte-Carlo Simulation is used to study the P10, P50, P90 values of maintained MPFMs. As a result, the variance between the values was small indicating the reliability of the MPFMs.

Patel et al. (2014) presented that for small fields, Model Based Multiphase Metering (MBMM) is a new method for the production allocation rates. This method is a flow model with real time measurements that can compete with alternative technology like Multiphase Flow Meters (MPFMs). It showed about 5% difference between the measured rates and calculated ones with flow model. As a case study, small Atlas gas-condensate field is used in their study. The Process model in the study is built by the combination of the K-Spice and Leda Flow modeling simulators. The model includes the wells, flowlines, inlet facilities and first stage separator in addition to all valves that are included in the model. When the system is in operation and in commingled mode, the results are yet to be proven. The flow model systems will continue to play a significant role in providing effective support for production optimization.

2.6 Partial Conclusions from the Literature Review

The following conclusions can be draw from the literature review in this study:

- Several studies have been carried out in the past 10 years on VFM technology. These studies show encouraging results applying VFM model as MPFM, metering backup or malfunction monitoring tool, and for production allocation applications.
- Although the recommend practices accepts VFM technology as alternative solution for multiphase flow measurement (particularly in subsea systems), they still have severe limitations on the use of VFM models. However, as can be seen from the literature review, there is a significant amount of work in the last decade showing that VFM technology have acceptable accuracy for several different VFM models and for wide range of field conditions.
- There is a significant number of studies in the last decade, however, these studies mostly focus on one single VFM method without doing a systematic analysis of the recommended practices.

There is still a gap of studies comparing different VFM models/correlation to identify the effect on VFM accuracy when using different models/correlations. Therefore, the objective of the current work is to carried out a systematic analysis of the questions described in section (Heddle, Foot, and Rees 2012) to evaluate the recommend practices for the state-the-art VFM models.

CHAPTER 3: DESCRIPTION OF THE VFM APPROACH USED IN THIS STUDY

There are a few different approaches currently available in commercial software which offer VFM solutions. These different approaches include steady-state or transient flow simulators, based on data validation and reconciliation, using a model based on one component (such as the reservoir, wellbore, choke valves, venture, orifice, or flowlines) or a model considering many components of the system interconnected (network model). Most of the VFM models commercially available are based on the conservations of mass, momentum, and energy equations. Using these conservations equations and the measurement of pressure and temperature changes through one or more components of the system, VFM models can estimate the flow rates of oil, gas, and water. However, there are always more than one flow model for each component in the production system. Therefore, it is important to evaluate how different flow models can affect the accuracy of VFM technology (Amin 2015).

This study uses a multiphase flow simulator software (PIPESIM 2013) to estimate flow rates over time for a particular deepwater field. The results of the flow rate determination using this multiphase flow simulator are compared to field data for different flow models for different components of the system (network model). A brief description of the flow models included in this commercial software package is presented next.

3.1 Network Model

The first-case network model is created without including the reservoir Inflow Performance Relationship (IPR) in the system. A schematic diagram of the network model is presented in Figure 3.1. The physical network model consists of four components:

- Reservoir (source node)

- Wellbore Model
- Choke Model
- Flowline Model
- Fluid Properties Model

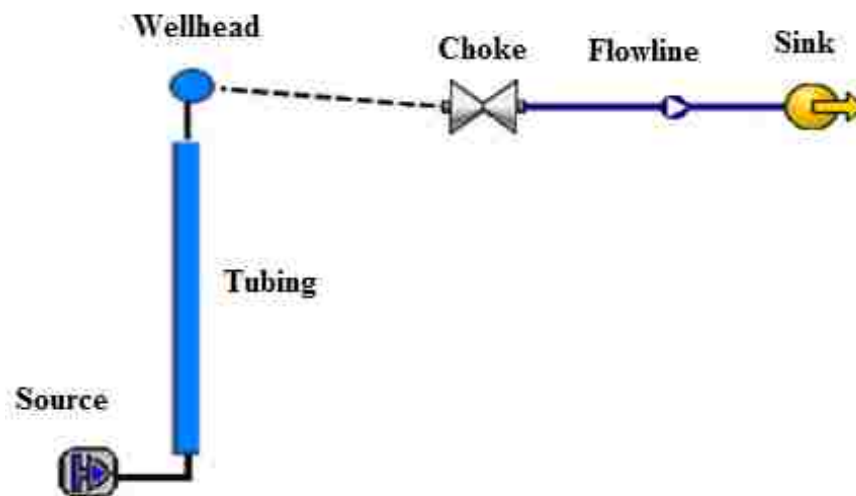

Figure 3.1 Schematic diagram for network model built for this study

The network model includes a fluid source (reservoir) at the bottom of the wellbore. The wellhead node is connected to the choke, and a flowline is added as a surface equipment to the system. In this network model, source node is the pressure/flowrate boundary condition. The bottomhole pressure and temperature are provided through the source node. The wellbore model is constructed using completions data and wellbore deviation survey. A sink node at the end of the network model provides a pressure condition.

3.2 Wellbore and Flowline Models

The pressure gradient equation (mechanical energy balance equation) is used for the wellbore and flowline models. This equation is derived from the combination of the conservation

of mass and momentum. The conservation of mass (for a constant pipe area) for the single-phase fluid flow in a pipe segment can be written as (Brill et al. 1999),

$$\frac{\partial \rho}{\partial t} + \frac{\partial(\rho v)}{\partial L} = 0 \quad (3.1)$$

And for steady state flow,

$$\frac{\partial(\rho v)}{\partial L} = 0 \quad (3.2)$$

The conservation of momentum can be expressed as

$$\frac{\partial(\rho v)}{\partial t} + \frac{\partial(\rho v^2)}{\partial L} = -\frac{\partial P}{\partial L} - \tau \frac{\pi d}{A} - \rho g \sin \theta \quad (3.3)$$

Combining equations (3.2) and (3.3), the pressure gradient expression can be written as,

$$\frac{dP}{dL} = -\tau \frac{\pi d}{A} - \rho g \sin \theta - \rho v \frac{dv}{dL} \quad (3.4)$$

The idea behind VFM models is to use the measurement of pressure drop between two distinct points in the production system and then estimate the flow rate. Once the pressure drop is measured, the flow rate can be determined by varying the flow rate to match the pressure drop, as the pipe wall shear stress (τ) and the third term of the right-hand-side in equation 4 (acceleration term) are a function of the flow velocity. However, equation 4 is only valid for single-phase flow. Therefore, if more than one phase is present, this equation would have to be fundamentally solved for each phase. If oil, gas, and water are present, at least three pressure drop measurements (six pressure points) from distinct points in the system would need to be obtained to solve this problem, as this problem would have three unknowns: oil, gas, and water flow rates (or phase velocities). Alternatively, a fluid properties model (based on vapor-liquid-equilibrium – which can determine the gas-liquid fraction in the fluid flow) and the use of the conservation of energy equation, can be

used to provide two additional equations to solve this system of equations, as long as the fluid composition and temperature changes measurements are available.

3.2.1 Enthalpy model

Application of energy conservation is used to predict the fluid temperature in the wellbore as a function of depth. Essentially, the conservation of energy equation can be used to provide two additional equations to solve this system of equations, as long as the fluid composition and temperature changes measurements are available. In steady-state and single-phase flow, the conservation of energy equation can be written based on the enthalpy gradient form for a constant pipe are as (Beggs 1991).

The heat flux Q , is directly proportional to the overall heat transfer coefficient and the temperature difference between the fluids and the surroundings. Therefore,

$$Q = U(T_f - T_e) \quad (3.5)$$

The steady state enthalpy gradient equation is made up of two components for our VFM system. w is the mass flow rate in the equation.

$$\frac{dh}{dL} = \frac{-U(T_f - T_e)\pi d}{w} - \frac{g \sin \theta}{g_c} \quad (3.6)$$

3.2.2 Multiphase flow models

Most of the flow models used to predict pressure drop for multiphase flow in pipes are derived from the pressure gradient equation (equation 4). The selection of these different multiphase flow models will essentially define the approach to obtain the pipe wall shear stress (τ) and the liquid holdup (liquid fraction in a pipe segment). The liquid holdup is used to determine the mixture fluid properties, such as mixture density and mixture viscosity.

In this study, Hagedorn and Brown multiphase flow model is used for the vertical wellbore and Beggs and Brill for the horizontal flowline (upstream to the choke valve). These two multiphase flow models are widely used in the oil and gas industry for multiphase flows in vertical and horizontal pipes, respectively. A sensitivity analysis was carried out with the field data obtained for this study and no significant changes in the flow rate predictions are obtained if other multiphase flow models are used for the wellbore and flowline (Hagedorn et al. 1965).

3.3 Fluid Properties Model

As described in the previous section, a fluid properties model can be used to provide the gas-liquid-fraction based on the vapor-liquid-equilibrium theory. Fluid models are used to determine the phase state and the phase thermodynamic and transport properties such as density, viscosity and enthalpy. In the simulations in this study, black oil model is used (McCain 1990). This model is widely used in the oil and gas industry and is very useful when detailed or reliable information about the compositional of the working hydrocarbon fluid is not available (which is the case of the field data obtained for this study).

Black oil fluids can be modelled in three phases and the amount of each phase is defined at stock tank conditions by defining two distinct ratios: Gas-Liquid-Ratio (GLR) and Water-Cut (WC). Once the GLR and WC are defined, the black oil model provides correlations for the fluid properties such as gas and liquid densities, viscosities, compressibility factor, solution gas-oil-ratio, and gas-liquid surface tension. These fluid property correlations for the black oil model are presented in Appendix A.

3.4 Choke Model

The fluid velocity increases through the choke and this velocity for compressible fluids reach sonic velocity. As the pressure difference across the choke increases, the flow velocity also increases. At the point the velocity becomes sonic, the flow is critical and it is independent of the

downstream pressure (Economides et al. 2012). In the simulation software used in this study there are three correlations available for subcritical flow, and nine correlations for critical flow (PIPESIM 2013):

- Subcritical flow correlations: Mechanistic, Ashford-Pierce, and API-14B (which is a slight modification from the mechanistic model).
- Critical flow correlations: Gilbert, Ros, Baxendall, Archong, Pilehvari, Omana et al., Mechanistic, Poetmann-Beck, Ashford-Pierce.

(Abdul-Majeed et al. 1991) presents a description and evaluation of the correlations for Gilbert, Ros, Baxendall, Archong, Pilehvari. The latter correlations use the same basic equation but different coefficients,

$$q_l = \frac{p_{up} 64 d^C}{A GLR^B} \quad (3.7)$$

where,

Table 3.1 Choke Correlation Coefficients

Correlation	A	B	C
Achong	3.82	0.650	1.88
Baxendall	9.56	0.546	1.93
Gilbert	10	0.546	1.89
Pilehvari	46.67	0.313	2.11
Ros	17.4	0.5	2.00

and p_{up} is the pressure upstream to the choke, d is the choke orifice, and q_l is the liquid flow rate.

The mechanistic and API-14B models used for subcritical and critical flow is described next.

3.4.1 Choke subcritical flow using the mechanics and API 14B models

The pressure loss across the choke is given by the weight average of the liquid and gas phase drops,

$$\Delta P = \frac{\rho_n \times v^2}{2 \times c} \times \left[\frac{\lambda_L}{(c_{vL} \times Z_L)^2} + \frac{\lambda_G}{(c_{vG} \times Z_G)^2} \right] \quad (3.8)$$

where,

$$\rho_n = \lambda_L \rho_L + \lambda_G \rho_G \quad (3.9)$$

$$v = \frac{q}{A_{\text{bean}} \times \rho_n} \quad (3.10)$$

$$Z_G = 1 - \frac{0.41 + 0.35 \delta^4}{\gamma} \times \frac{\Delta P}{P_{up}} \quad (3.11)$$

where, ρ_n is the non-slip density, v is the mixture velocity, A_{bean} is the choke area, λ_l and λ_g are the liquid and gas phase flowing fractions, Z_l and Z_g are the liquid and gas compressibility factors, and γ is the gas specific gravity.

For the API-14B model the gas and liquid discharge coefficients are constant values of $c_{vg} = 0.9$ and $c_{vl} = 0.85$, respectively. The liquid flow is assumed incompressible, and gas flow incompressible and adiabatic.

3.4.2 Choke critical flow using the Mechanistic and API-14B models (PIPESIM 2013)

The correlations that are used for the choke critical flow and the subcritical flow correlation (mechanistic) are same, the only difference is the addition of the following assumptions,

$$\Delta p = (1 - C_{PR})p_{up} \quad (3.12)$$

where, C_{PR} is the critical pressure ratio as proposed by Ashford-Pierce.

CHAPTER 4: PERFORMANCE EVALUATION OF DIFFERENT VFM MODELS USING FIELD PRODUCTION DATA

This chapter describes the evaluation of the performance of different VFM models using field data gathered for this study. The VFM model described in Chapter 3 and other five commercial packages will be compared with this field dataset. The objective of these evaluations is to provide a detailed description on the impact of VFM models for different multiphase flow correlations and also the different components of the production system such as reservoir, wellbore, choke valve and flow line, and also evaluate the performance of the commercial packages on flow rate determination. The results from these evaluations will provide guidance for the industry and regulatory agencies on the current performance of VFM technology and also discuss the effect of the components on the production system on VFM performance.

4.1 Description of the field data collected for this study

Two wells are producing from a particular offshore deepwater field. The production history data spans over two years. Only some parts of the production dataset have reliable production data after detailed analysis of the data set. The fact that part of the dataset is not reliable is a good opportunity to use VFM models to “flag” problems with the dataset, which can be potentially used in the field as application for VFM technology. For example, water-cut values are not correct for a portion of the dataset, and there is no temperature information for last two months of year two. The dataset includes daily measurements of pressure and temperature at different locations of the production system (bottomhole, wellhead, upstream and downstream to the choke valve), choke openings, oil, gas, and water flow rates. Limited fluid property information was also available. During the two years of the production data available, fifteen evaluations points were selected. These points were selected during periods of time when the flow rates are not changing significantly for at least three days, to assume steady-state conditions. Also, the evaluation points

were selected to provide a wide range of gas-liquid-ratios, oil, gas and water production, and for various choke openings. The range of condition for this field dataset can be described as the following:

- Gas-Oil-Ratio: 2,000 to 4000 SCF/BBL
- Water-Cut (ratio between water and total liquid rate): 4% to 75%
- Choke opening: 8/64 to 35/64ths of an inch

Figure 4.1 shows a production history of flow rates and bottomhole pressures over time, for the different evaluations points for the field data collected for this study. The actual values for this plot are removed due to the confidentiality of the field data. All results in this study will only show percentage errors between simulated and measured filed data. The actual values will also be omitted in this dissertation.

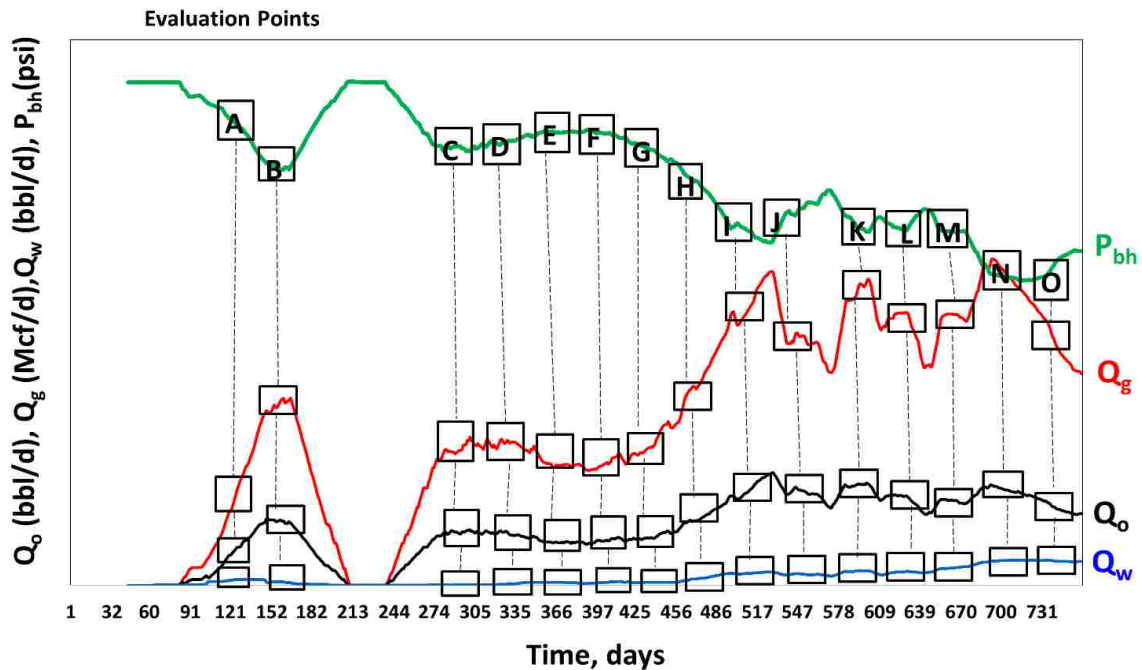

Figure 4.1 Production data used in this study. Each selected point corresponds to the evaluation point used during the performance evaluations of the VFM models investigated in this study

4.2 Cases of Investigation

Six different cases are defined to evaluate the different VFM models with the available field data:

1. Case 1: 15 evaluations points (A to O) are selected from production history with bottomhole, wellhead, upstream & downstream choke pressures and temperatures. Gas-Liquid-Ratio (GOR) and Water-Cut (WC) for two initial points (A and B) are also provided.
2. Case 2: Same as Case 1 but with the additional information about the well Productivity Index (PI).
3. Case 3: GOR is provided for all remaining points (C to O).
4. Case 4: Three points of oil and gas flow rates are disclosed from early production data (points A, B, C). The flow model is tuned by using these three flow rates, and simulation are performed to estimate the flow rates for the remaining points (D to O).
5. Case 5: Oil and gas flow rates are provided for other two points at mid-time production (points G and H). The objective of this case is to improve on prior estimates (points D, E, and F) and fine tune the flow models to improve future predictions (G to O).
6. Case 6: Measured water cut data points are provided for late production time (last 3 points: M, N, and O). The objective of this case is to evaluate the combined effect of water cut and GOR on fine-tuning flow rate predictions.

For all the cases, the table below presents the given range of fluid properties obtained from the field data used in this study.

Table 4.1 Fluid Properties

Fluid Property	Range
API	22.5 to 33
Gas specific Gravity	0.45-0.6
Water Specific Gravity	0.95-1.1

It is important to mention that the oil, gas, and water flow rates were not disclosed during the VFM simulations. The data described for the different cases were disclosed in a chronological sequence (from Case 1 to 6), to make sure that the personnel involved on doing the simulations would have the same challenges as if the VFM was being used in the field. In other words, the personnel performing the simulations were given information to perform future predictions and flag problems or determine flow rates based on the given information of pressure and temperature measurements, without the knowledge of the actual flow rates.

4.3 No-Tuning Case Results

4.3.1 Case 1 – Two points of GOR and Water cut

For this case, four models are used in the VFM approach used in this study: hydraulic wellbore and choke model, fluid model, and energy balance model. Pressures and temperatures from the production dataset for bottomhole, wellhead, upstream and downstream to the choke, are given as input data for the flow models. Table 4.2 shows the given information to perform the flow rate predictions for Case 1. The given data in Table 4.2 highlighted in green is used as input data, while the data highlighted in blue show the given data that will be used to compare with the calculated data from the 22 simulations. The flow rates of oil, gas and water are manually varied to match as close as possible the given data in blue (wellhead pressure and temperature). The non-highlighted data (temperature upstream and downstream to the choke) show the data that are not used in the flow predictions. As presented in Table 4.2, GOR and WC are given for two evaluation points A and B (early production data).

Table 4.2 Case 1 input data

Eval. Points	Allocated Gas (Mmcf/d)	Allocated Oil (Bbl/d)	Allocated Water (Bbl/d)	Allocated Liquid (Bbl/d)	GOR (scf/s tb)	Water Cut (%)	BHP (psi)	BHT (F)	WHP (psi)	WHT (F)	Upstream of choke temp (F)	Choke (/64ths)	Downstream of choke pressure (psi)	Downstream of choke Temp (°F)
A					X	X	X	X	X	X		X	X	
B					X	X	X	X	X	X		X	X	
C							X	X	X	X		X	X	
D							X	X	X	X		X	X	
E							X	X	X	X		X	X	
F							X	X	X	X		X	X	
G							X	X	X	X		X	X	
H							X	X	X	X		X	X	
I							X	X	X	X		X	X	
J							X	X	X	X		X	X	
K							X	X	X	X		X	X	
L							X	X	X	X		X	X	
M							X	X	X	X		X	X	
N							X	X	X	X		X	X	
O							X	X	X	X		X	X	

The software package (PIPESIM, 2013) used in this study was not originally designed as a Virtual Flow Metering (VFM) model. However, this software package is used here as a VFM model. Flow rates of oil, gas and water can be determined manually without the use of an automatic system to match the information given in Table 4.2. Commercial VFM packages would calibrate the flow rate using an automatic system (e.g., an optimization algorithm). Therefore, further improvements in the prediction results would be expected in all cases in this study if an automatic system uses a similar model. Nevertheless, the prediction trends are expected to be within reasonable agreement with other commercial VFM packages.

The procedure for the manual estimation of flow rates used in this study is the following:

1. For each evaluation point in Table 4.2, the highlighted data in green is used as input data in the VFM model. Each evaluation point means a different simulation run.

2. Given fluid properties are also added as input data. Black oil model is used in the model. Therefore, only water cut, GOR, oil, gas and water specific gravities are need. GOR and Water cut are given only for evaluation points A and B. For the evaluation points where GOR and Water cut are not given, these two parameters are estimated as described in step 6.
3. Enthalpy balance model is enabled to allow for temperature predictions. Overall heat transfer coefficient ($U=0.75$ Btu/hr/ft²) is used as an input data for this model.
4. Flow correlations are selected for wellbore and flowline. In this study, Hagedorn and Brown correlation is used for the wellbore (vertical well), and Beggs and Brill correlation was selected for the flowline (horizontal pipe).
5. Sensitivity analysis is performed for the choke model. There are three models for subcritical and nine models for critical conditions at the choke. Therefore, to obtain the model that best fits the production data, two models are used for sub-critical (Mechanistic and Ashford) and 3 models (Mechanistic, Gilbert, and Ashford) for critical flow in the choke. These selected models were used to predict pressure and temperature upstream to the choke for all evaluation point in Table 4.2. Then, the difference (error percentage) between the calculated and measured pressure and temperature upstream to the choke is plotted as shown in Figure 4.2 and Figure 4.3. The choke model with least error summation is selected to be used in the flow rates prediction.
6. After the choke model is selected and all input data is entered, GOR and water cut have to be entered in the model. For this case, GOR and Water Cut were given only for

evaluation points A and B. Therefore, for the remaining evaluation points (C, D, E, ...), the following procedure is used:

- a) GOR and Water Cut from the previous evaluation point are used as initial guess. Then, the simulation is run to calculate oil, gas and water flow rates, and wellhead pressure and temperature.
- b) Calculated wellhead pressure and temperature are compared to the measured values given in Table 4.2 for the corresponding evaluation point. The initial error between the measured and estimated values for wellhead pressure and temperature is recorded.
- c) 5% is added to the previous value of GOR and Water Cut in step “a”. Then, the calculated wellhead pressure and temperature are compared again to the measured values. The error between the measured and estimated values is recorded.
- d) The error calculated in step “c” is subtracted from initial error obtained in step “b”. If this subtraction result is a negative number, go back to step “c” and subtract 5% from the current GOR and Water Cut values, and then go to step “e”. If the difference is positive, go to step “f”.
- e) 5% is subtracted to the current value of GOR and Water Cut in step “d”. Then, the calculated wellhead pressure and temperature are compared again to the measured values. The error between the measured and estimated values is recorded.
- f) Compare the error with the tolerance. The tolerance used in this study is 5% of the initial guess for the wellhead pressure and temperatures. If the error is smaller than the tolerance, select the current GOR and Water cut most appropriate values. If error is large than tolerance, go back to step “c”.

7. Input the selected GOR and Water Cut to the fluid model. Then, run the simulation to estimate the flow rates of oil, gas and water. Figures 4.8 and 4.9 show the comparison between given (measured) and estimated wellhead pressure and temperatures for the final values of GOR and Water Cut. These figures illustrate the final errors on predicting wellhead pressure and temperature, which is dependent of the final selection of GOR and Water Cut from step “f”.

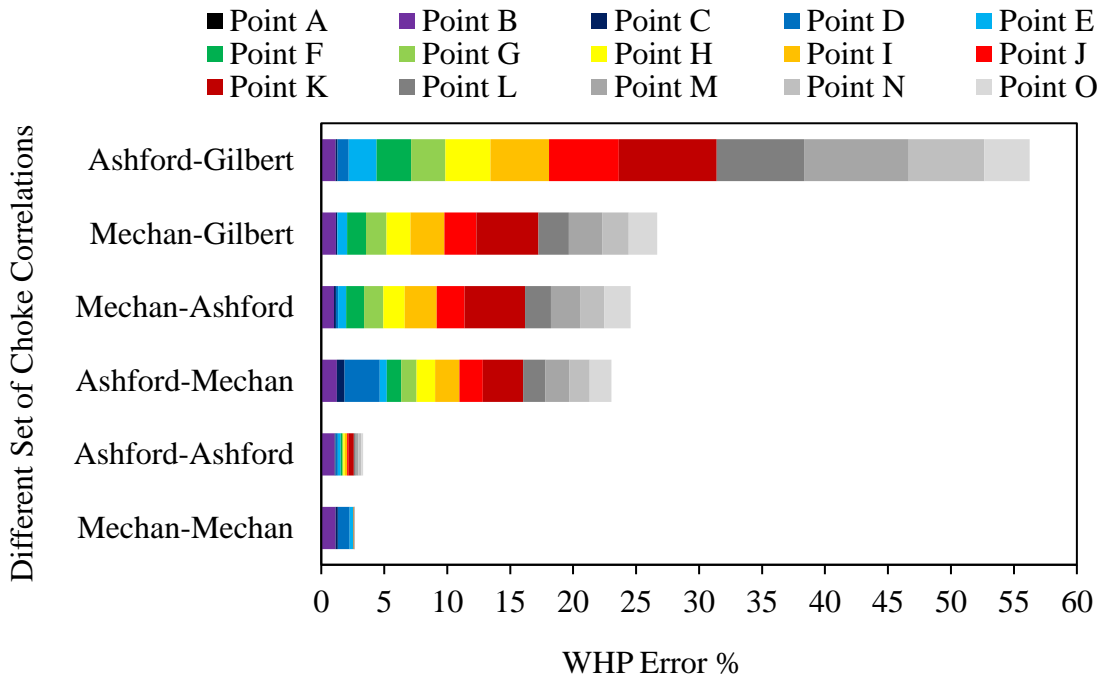

Figure 4.2 Error percentage between predicted and measured wellhead pressures for different sets of choke correlations for all evaluation points.

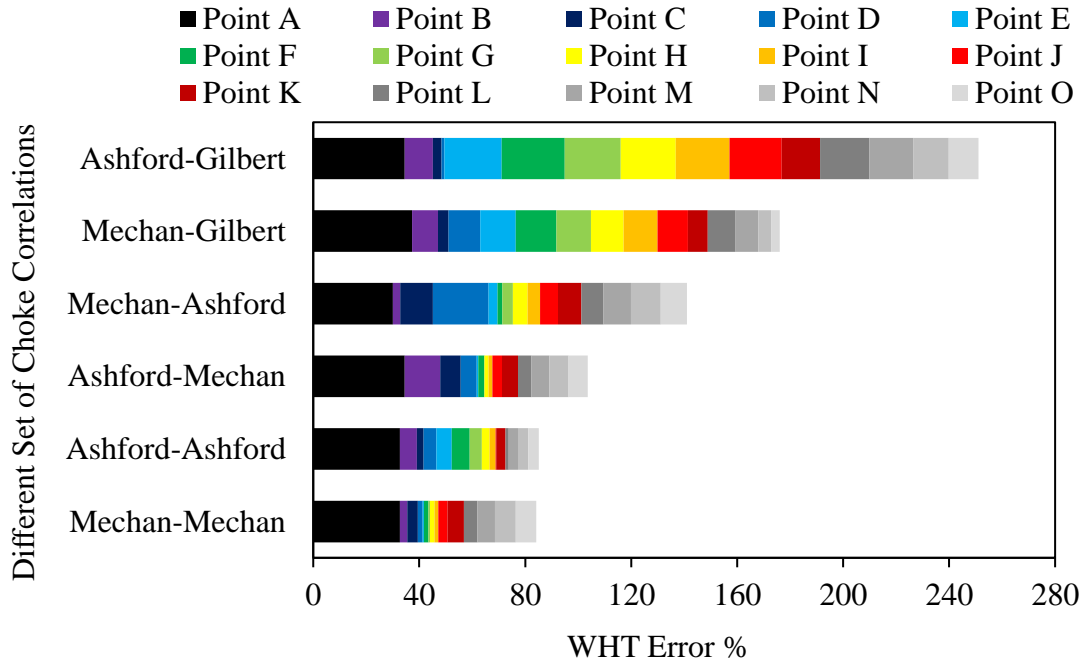

Figure 4.3 Error percentage between predicted and measured wellhead temperatures for different sets of choke correlations for all evaluation points.

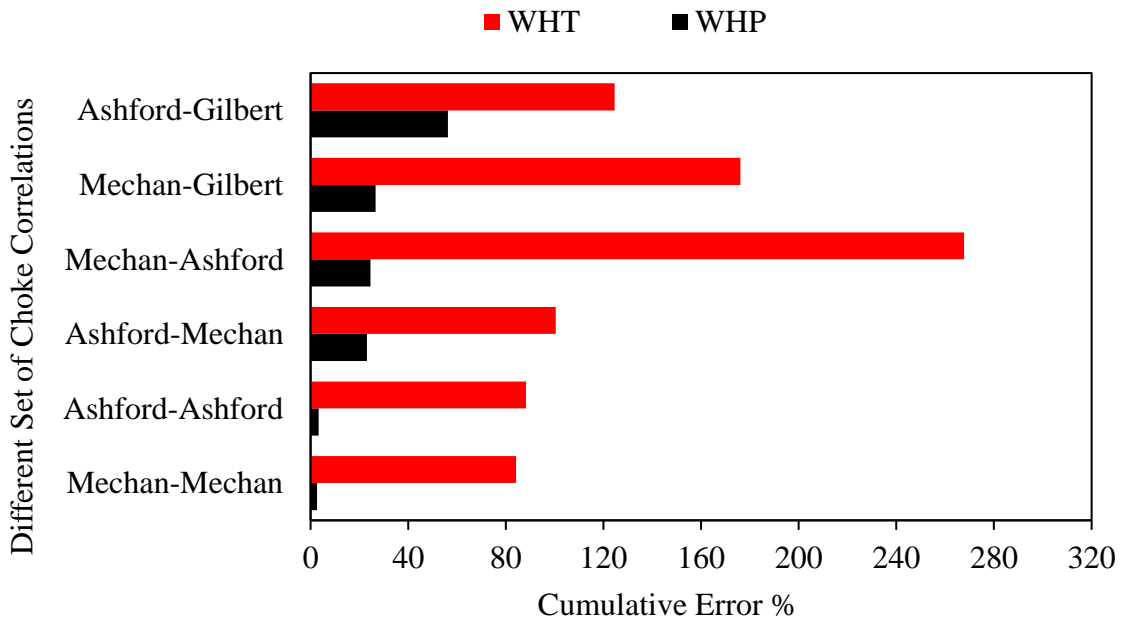

Figure 4.4 Cumulative error percentage between predicted and measured wellhead pressures & temperatures for different sets of choke correlations for all evaluation points

The choke correlation pair 1 in figure 4.4 (which is the Mechanistic-Mechanistic choke model), is selected for the flow prediction simulations for cases 1, 2, 3. As it is shown in figure 4.4, the choke correlation pair 1 has the least cumulative error in comparison with other pairs. However, choke correlation pair 2 (Ashford-Ashford choke model) show close cumulative error percentage to pair 1. Ashford correlation is often reported (Lannom et al. 1996) to give reasonable predictions for flow rates less than 2,000 stb/d. At higher flow rates, the Ashford correlation tends to underpredict the flow rate. Our data set have flow rates higher than 2000 stb/therefore. Thus, the mechanistic correlation is used for the first three cases in this study (cases 1,2,3).

Figure 4.5 to 4.9 show the oil, gas and water flow rate predictions, pressure and temperature matching for Case 1. The oil, gas and water flow rate determination was obtained by varying the flow rates of oil, gas and water to match the pressure and temperature at the wellhead.

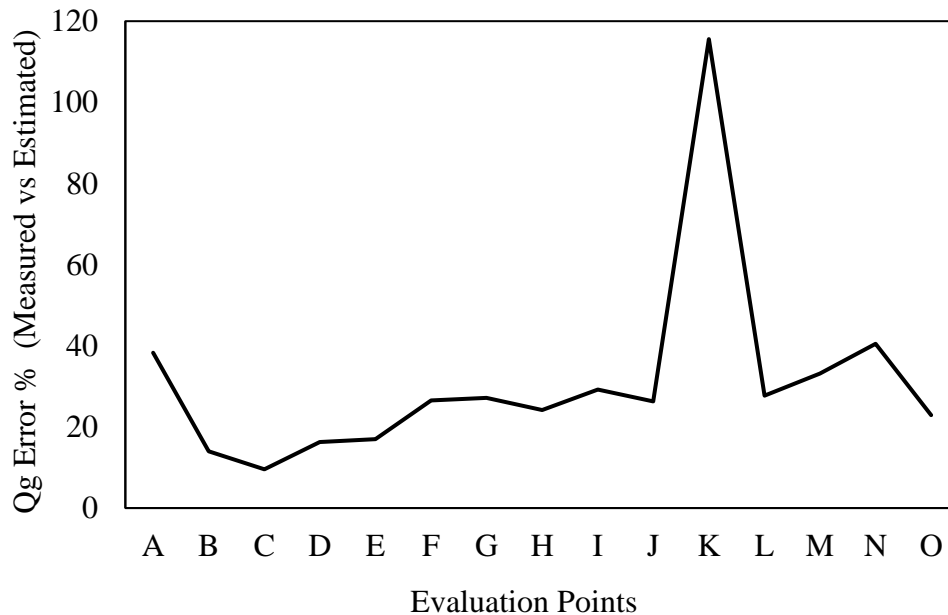

Figure 4.5 Error percentage between predicted and measured gas flow rates for evaluation points A through O for case 1

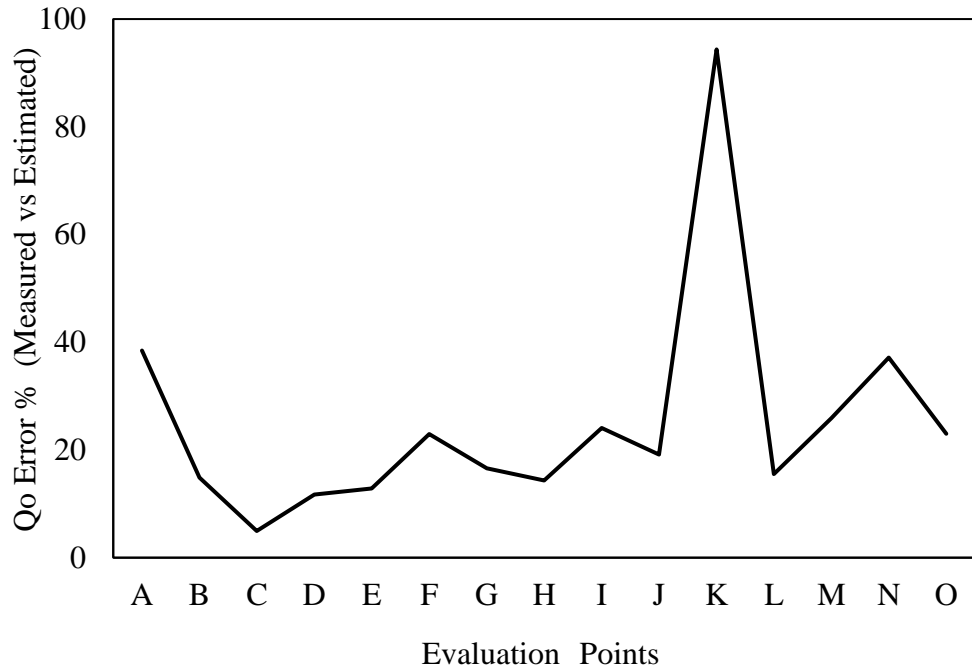

Figure 4.6 Error percentage between predicted and measured oil flow rates for evaluation points A through O for case 1

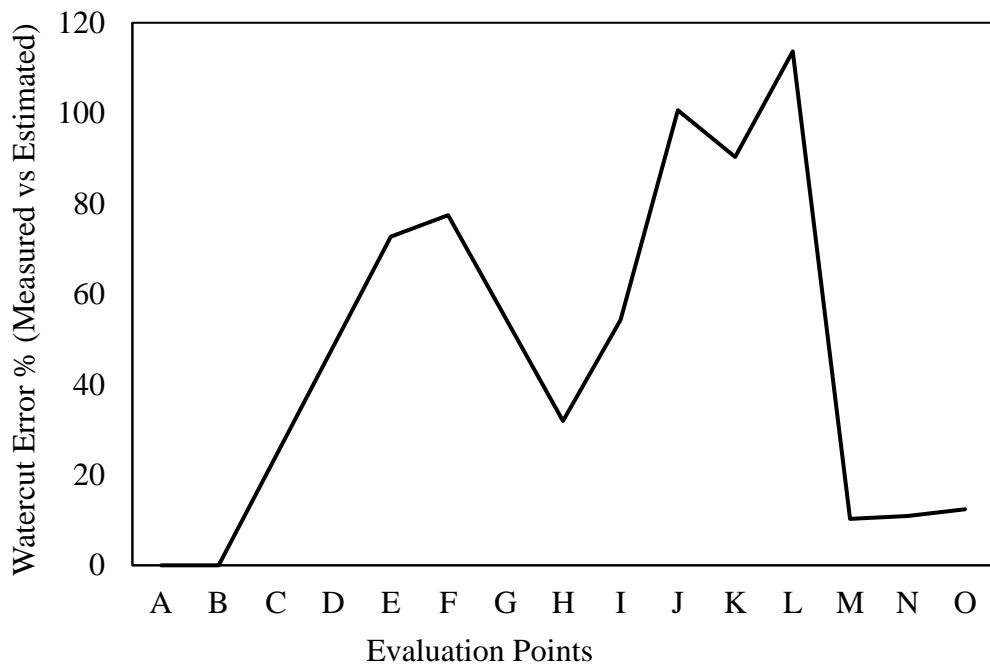

Figure 4.7 Error percentage between predicted and measured water flow rates for evaluation points A through O for case 1

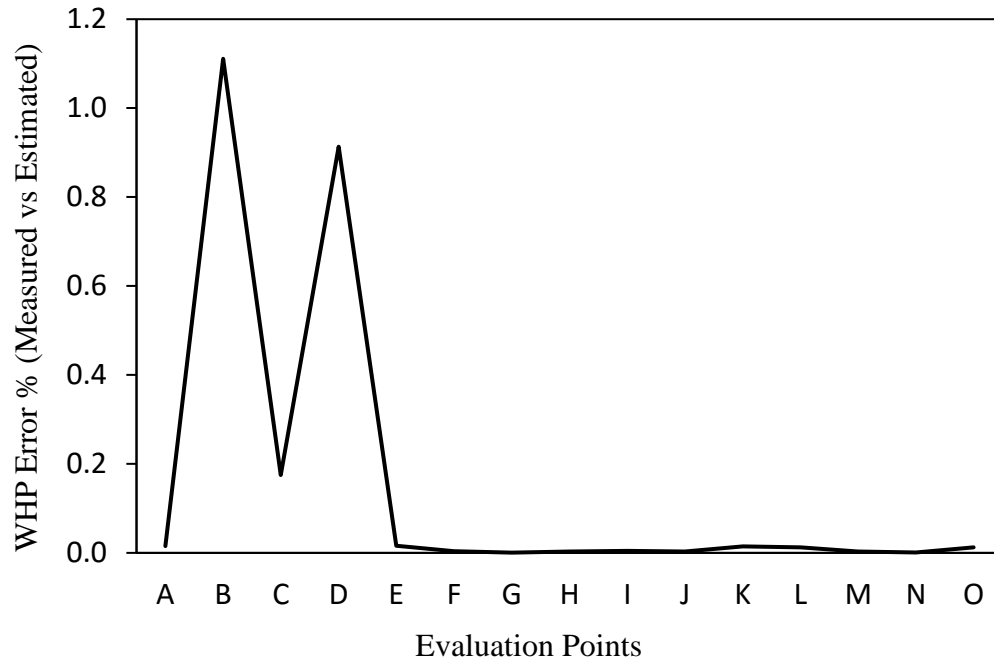

Figure 4.8 Error percentage for wellhead pressure matching for predicted oil and gas flow rates for case 1

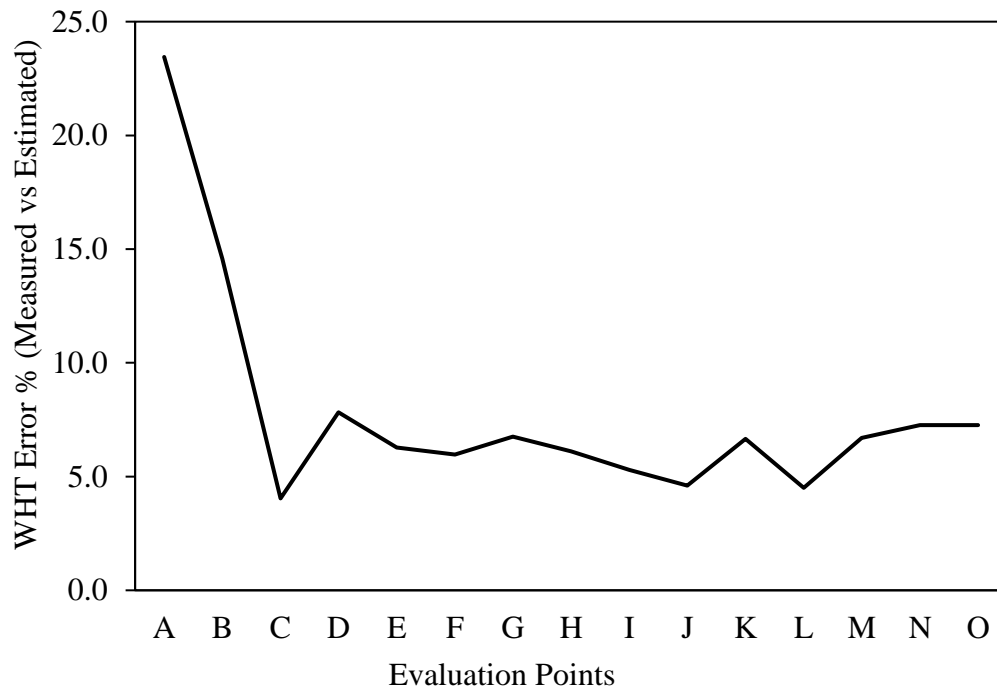

Figure 4.9 Error percentage for wellhead temperature matching for predicted oil and gas flow rates for case 1

The following conclusions can be drawn from the results obtained from Figure 4.5 to 4.9), and from the VFM simulations:

1. Different wellbore models (OLGA, Hagerdorn & Brown, Tulsa) and choke models (Gilbert, Ashford- Pierce) do not seem to have a significant impact on the estimated flow rates.
2. Most of the well is under single-phase liquid condition for all evaluations points. Only a very small portion of the well is in two-phase flow. Also, Reynolds number in the wellbore is considerably low. The hydraulics model in the wellbore would primarily capture the effect of liquid density and not significantly capture changes in flow rates.
3. The choke model would be the primary model capturing changes in the flow rate. However, for this data set, the fluid flow through the choke has a very low Gas-Volume –Fraction (GVF). This would make the predictions relatively easier when compared to all possible cases that can be found in the field, since small gas-volume-fractions (GVF) is flowing through the choke for this data set. Choke models are known to have a better prediction for small gas-volume fractions and smaller openings (e.g., critical flow conditions).
4. Conclusions 2 and 3 above should be the main reason why the different flow models did not show significant changes while estimating the flow rates. The models tested are considerably similar for single-phase liquid in the wellbore, for critical flow conditions and very low GFV in the choke.
5. Based on the conditions of this date set and item 4 above, pressure data particularly for wellhead pressure, was primarily used to predict GOR. Choke models was basically used to predict oil flow rates.

6. Temperature data was primarily used to predict water cut in our simulations. Wellhead temperature has a larger sensitivity to water content than to oil and gas, as the heat carrying capacity of water is significantly larger for water than for oil and gas.
7. Temperature data for upstream and downstream choke in Points A and B (see Figure 4.8) are not physically consistent. There is a significant change in the temperature for only these two points. The pipe was described as insulated by the engineers from where the field dataset is coming from. If that is the case, the given GOR and Water cut would not probably provide this significant temperature change in the fluid flow between the choke and PLET (based on our simulations and assuming 80 ft long insulated pipe between choke and PLET).
8. If we consider that the temperature data is not reliable (or inaccurate) as described in item 7 above, the water cut will likely have larger deviations in flow rate when compared to oil or gas predictions in our simulations.
9. More reliable temperature data together with more information about pipeline (jumper geometry and insulation characteristics) connecting choke and PLET would likely increase the prediction of water cut for our simulations. Also, as Figure 4.6 shows too many points with large errors, there is the possibility of a malfunction of the water flow meter.
10. The error percentage for matching the wellhead pressure is significantly lower (around 1% - see Figure 4.8) than the wellhead temperature (Figure 4.9). The errors for wellhead pressure are within the uncertainty range ($\pm 1\%$) of pressure measurements for this type of sensor.

4.3.2 Case 2 – Productivity Index (PI), and two points of GOR and Water cut

This case is the same as Case 1, but Productivity Index (PI) is included as input data. The source node is replaced by a well node and reservoir fluid properties in addition to productivity index are provided in the system. The network model now consists of five components: i) IPR, ii) wellbore, iii) choke, iv) flowline, and iv) fluid model.

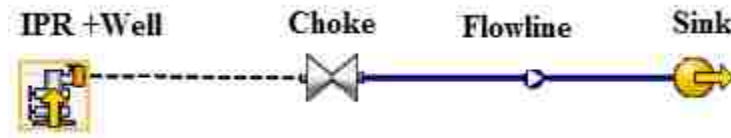

Figure 4.10 Schematic of well with IPR model included

The simulation branch is started from the reservoir until the sink (downstream of the choke). The Inflow Performance Relationship (IPR) model is used to model the flow of the fluids from the reservoir through the formation to the wellbore. PIPESIM offers a detailed list of IPRs for both oil and gas reservoirs such as:

- Well PI
- Vogel
- Fetkovich
- Jones/Forchheimer
- Backpressure equation

Well PI (liquid) relationship for liquid reservoirs is the simplest and widely used IPR equation, which is also used here. It states that the liquid flow rate is directly proportional to pressure drawdown between the bottomhole and the reservoir.

$$Q_L = PI * (P_R - P_{Wf})$$

where,

$$Q_L = \text{Stock - tank oil rate}$$

P_R = Reservoir Pressure

P_{wf} = Bottom hole Pressure

PI = Productivity Index

Reservoir properties such as reservoir pressure and temperature and productivity index are included into the model for Case 2. Productivity Index (PI) is fixed as $PI = 0.71$ for all evaluations points, from A through O. Reservoir properties implicitly included in PI such as thickness (h), oil formation volume factor (B_o) and viscosity (μ_o), skin factor (s), reservoir radius (r_e) and wellbore radius (r_w) are assumed to not change significantly over a short period of time. However, a considerable change in skin factor may occur if, for instance, water-coning start to occur in the near wellbore region, which will can decrease permeability significantly. However, this effect was assumed to be negligible. The reservoir pressure was also adjusted to match the given bottomhole pressures. Table 4.3 and table 4.4 show the reservoir information and fluid characteristic used in this study, respectively.

Table 4.3 Reservoir Data

Variable	Value	Unit
Reservoir Pressure (Pr)	13,021	psi
Reservoir Temperature (Tr)	217	F
Permeability	NA	mD
Thickness Net Pay	40	ft
Productivity Index	0.715	bpd/psi

Table 4.4 Fluid Characteristic

Variable	Value	Unit	Uncertainty
Oil Gravity	23.50	API	5%
Gas Gravity	0.613	Air=1	2%
Saturation Gas Oil Ratio	2,850	scf/Stb	5%
Water Salinity	196,000	mg/L	2%
Thickness Net Pay	40	ft	N/A

Table 4.2 shows the given information to perform the flow rates predictions for Case 1, which is the same for Case 2, but including the $PI = 0.715 \text{ bbl/d/psi}$.

Figure 4.11 to Figure 4.13 show the prediction results for Case 2 for evaluation points A through O for oil, gas and water flow rates. Case 1 also is added to these figures to compare both case results. Figure 4.14 and Figure 4.15 present the comparison between the given and estimated wellhead pressure and temperature, respectively, while predicting the flow rates for Case 2.

Procedure for manual estimation of flow rates for Case 2:

The procedure used to estimate flow rates in Case 2 is the same as for Case 1. The only difference is that in Case 2 we used the given (measured) bottomhole pressure from Table 4.5 to be compared with the calculated bottomhole pressure, as the PI is given and the reservoir pressure has to be estimated in order to calculate bottomhole pressure and temperature.

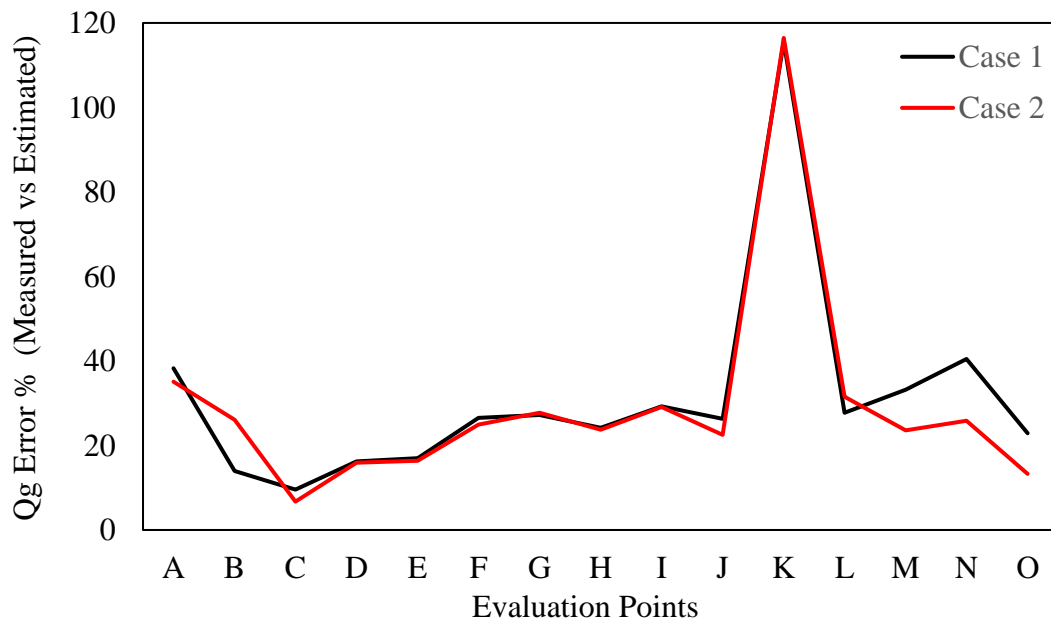

Figure 4.11 Error percentage for predicted gas flow rates for evaluation points A through O for cases 1 & 2

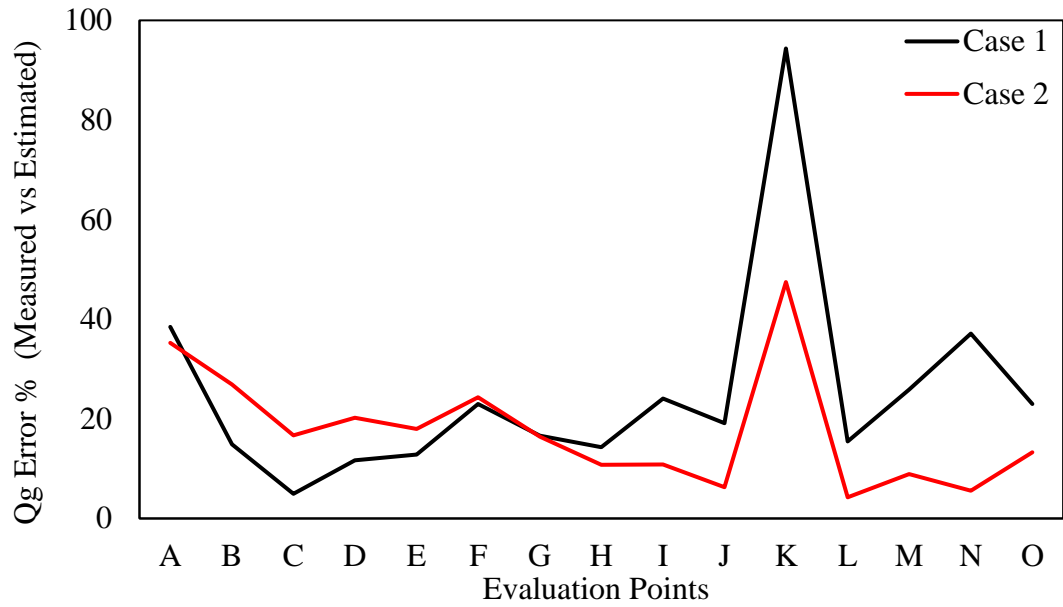

Figure 4.12 Error percentage for predicted oil flow rates for evaluation points A through O for cases 1 & 2

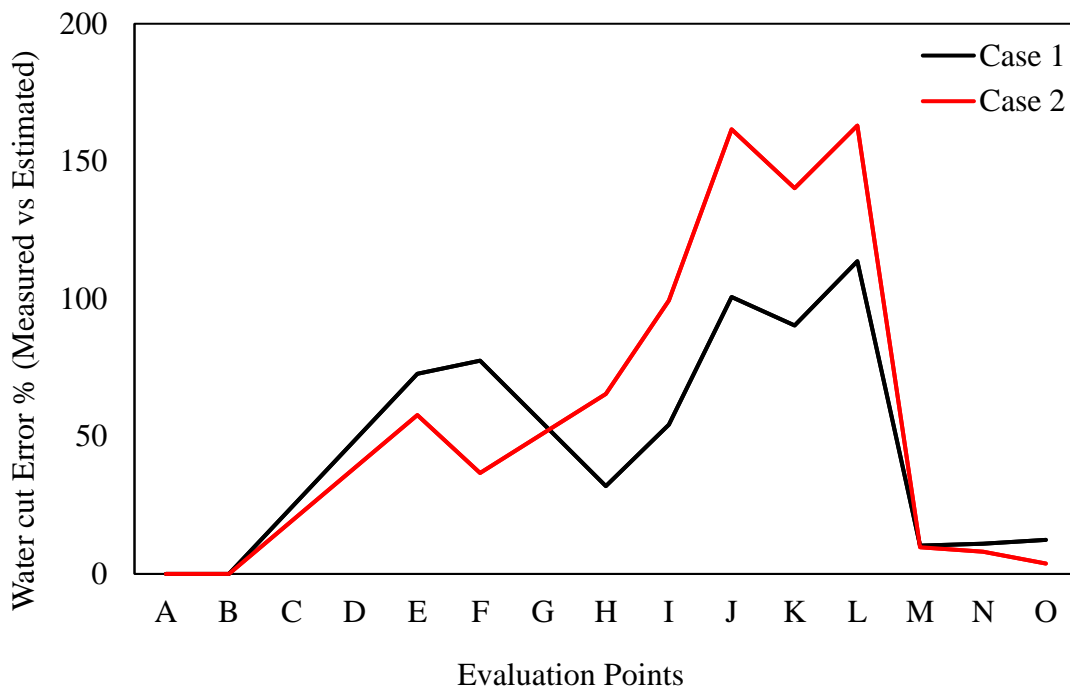

Figure 4.13 Error percentage for predicted oil flow rates for evaluation points A through O for cases 1 & 2

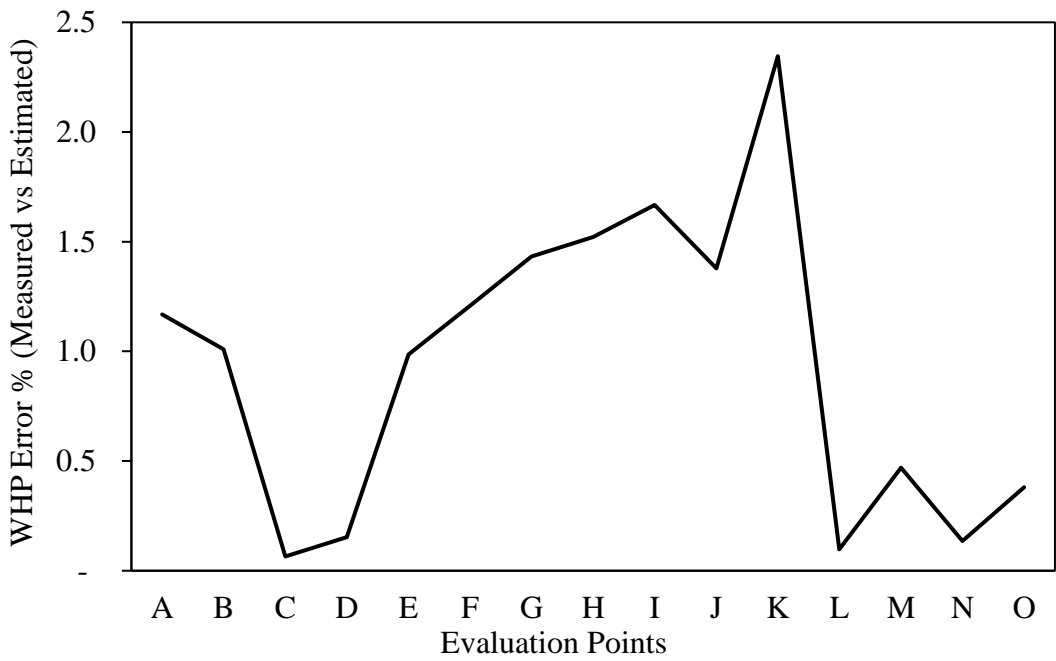

Figure 4.14 Error percentage for wellhead pressure matching for predicted gas & oil flow rates for case 2

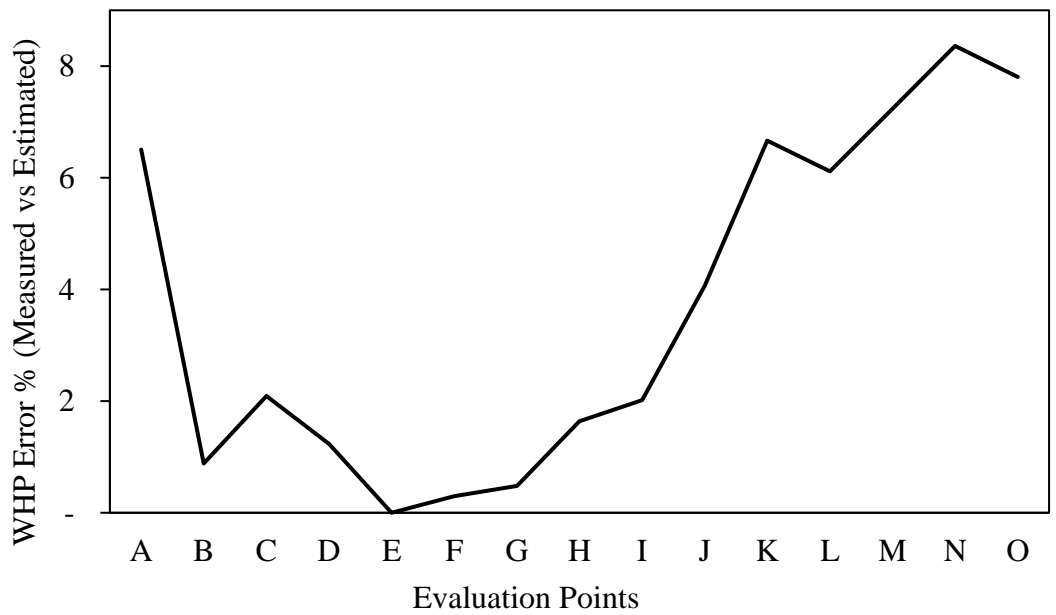

Figure 4.15 Error percentage for wellhead temperature matching for predicted gas & oil flow rates for case 2

The main difference between Case 1 and Case 2 is the addition of the IPR model in Case 2. For Case 2, more models than needed are available. In other words, in Case 2 we have 4 models available (IPR, wellbore, choke, and fluid model) and we have only three unknowns: oil, gas and water flow rates. In this case, the IPR model is used to predict oil rate, the choke model to predict gas rate and wellbore model (base on conservation of energy in the wellbore) was used to estimate water cut. The fluid model was not used directly here to tune the flow rates prediction. Figure 4.16 shows average error percentage for cases 1 and 2 to compare the average errors (error between measured and estimated flowrates) of two cases simultaneously. While comparing Case 1 and 2 in Figure 4.16, it is possible to conclude that the addition of the information about the reservoir does not significantly improve the flow rates predictions. The average error is about 25% for both cases which indicates that some flowrates data as input to the system are required to tune the model in in order to decrease the error percentage between the measured and estimated flowrates.

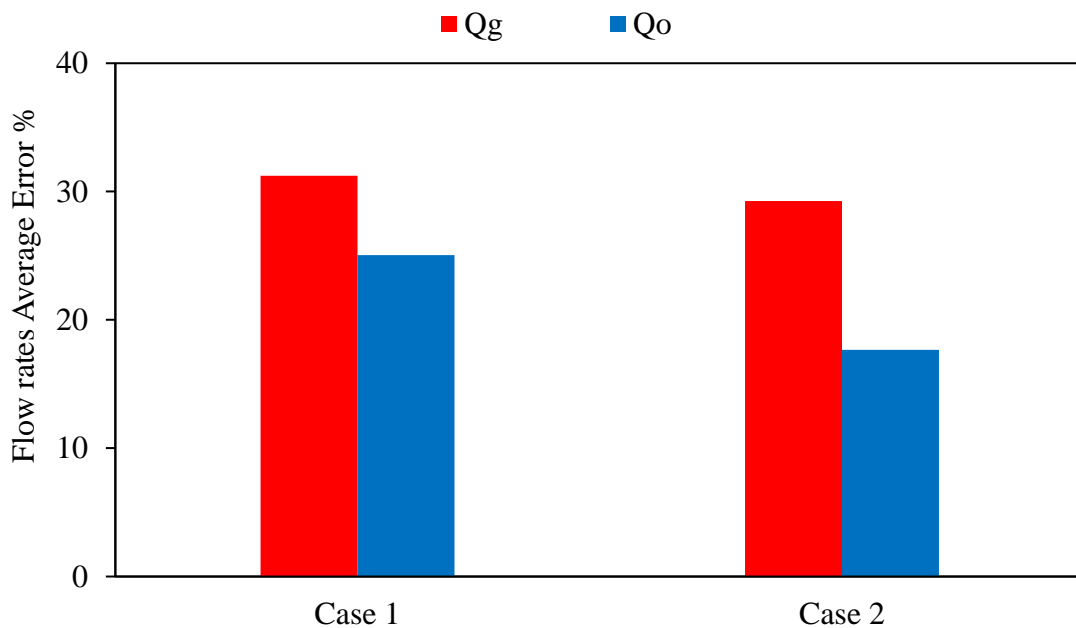

Figure 4.16 Average error percentage for gas and oil flowrates for cases 1&2

4.3.3 Case 3 – Productivity Index (PI), all points of GOR, and two points of Water cut

In this case, the network model consists of five components: i) IPR, ii) wellbore, iii) choke, iv) flowline, and iv) fluid model. Case 3 is the same as the previous cases 1 and 2, with the only difference that the measured GOR values are provided for all remaining points (C to O) as shown in Table 4-5. The objective of this case is to evaluate improvement in future prediction of oil, gas and water flow rates when providing complete GOR information.

Table 4.5 shows the input data that are given for Case 3. The input data are same as Cases 1 and 2. The blue cells show the given values that will be used to compare with the calculated by the flow model, while the green cells show the measure values that are entered in the model as input data.

Table 4.5 Case 3 input data

Eval. Points	Allocated Gas (Mmcf/d)	Allocated Oil (Bbl/d)	Allocated Water (Bbl/d)	Allocated Liquid (Bbl/d)	GOR (scf/s tb)	Water Cut (%)	BHP (psi)	BHT (F)	WHP (psi)	WHT (F)	Upstream of choke temp (F)	Choke (/64ths)	Downstream of choke pressure (psi)	Downstream of choke Temp (°F)
A					X	X	X	X	X	X		X	X	
B					X	X	X	X	X	X		X	X	
C					X		X	X	X	X		X	X	
D					X		X	X	X	X		X	X	
E					X		X	X	X	X		X	X	
F					X		X	X	X	X		X	X	
G					X		X	X	X	X		X	X	
H					X		X	X	X	X		X	X	
I					X		X	X	X	X		X	X	
J					X		X	X	X	X		X	X	
K					X		X	X	X	X		X	X	
L					X		X	X	X	X		X	X	
M					X		X	X	X	X		X	X	
N					X		X	X	X	X		X	X	
O					X		X	X	X	X		X	X	

Gas and oil flow rate predictions are shown in Figure 4.17 and 4.18, where two previous cases 1 and 2 data are also added to the figures. All three Cases 1, 2 and 3 show virtually the same flow rate prediction for gas flow rate, as shown in Figure 4.17.

For oil flow prediction, figure 4.18 shows that Cases 1 and 2 have relatively the same trend as case 3. However, there is a spike in evaluation points such as K that show differences larger than 50% when comparing gas oil flow rate prediction for three cases. This peak with high percentage error is due to boundary between the critical and subcritical flow of the choke, so there is a transition from choke critical flow to subcritical flow. Also, it is important to mention that Case 3 is more similar to Case 1 than to Case 2, even though Case 2 has one more given input data (PI given) than Case 1. As Case 3 has the measured GOR as input data, it suggests that Case 3 has likely the most accurate predictions and the given PI for Case 2 is not reliable. Figure 4.19 shows the watercut error percentages. There is a huge error percentage from point D to point L. In practice these large errors on water flow rate prediction would indicate malfunction of the flow meter. In fact, the operator which provided the field data for this study confirmed that after point L, the water flow meter was re-calibrated, and the previous measurements (between points D and L) probably have erroneous measurements due to flow meter malfunction. Figures 4.20 and 4.21 show the wellhead pressure and temperature error percentage between measured and estimated data. The average errors are mostly between 2%-5% for both figures, which indicate that there is a reasonable and acceptable match between estimated and measured pressure and temperature data while predicting the flowrates of the cases with the model. Figure 4.22 shows average error percentage for cases 1, 2 and 3 to compare the average errors (error between measured and estimated flowrates) for the three cases simultaneously. The flowrates error percentages are slightly higher for case 3 in comparison with other two cases. However, it is not a considerable error difference among three

cases. This imply that, addition of GOR data to the system is not sufficient, and we need some accurate watercut measurement data to add to the flow model in order to tune the model more rigorously.

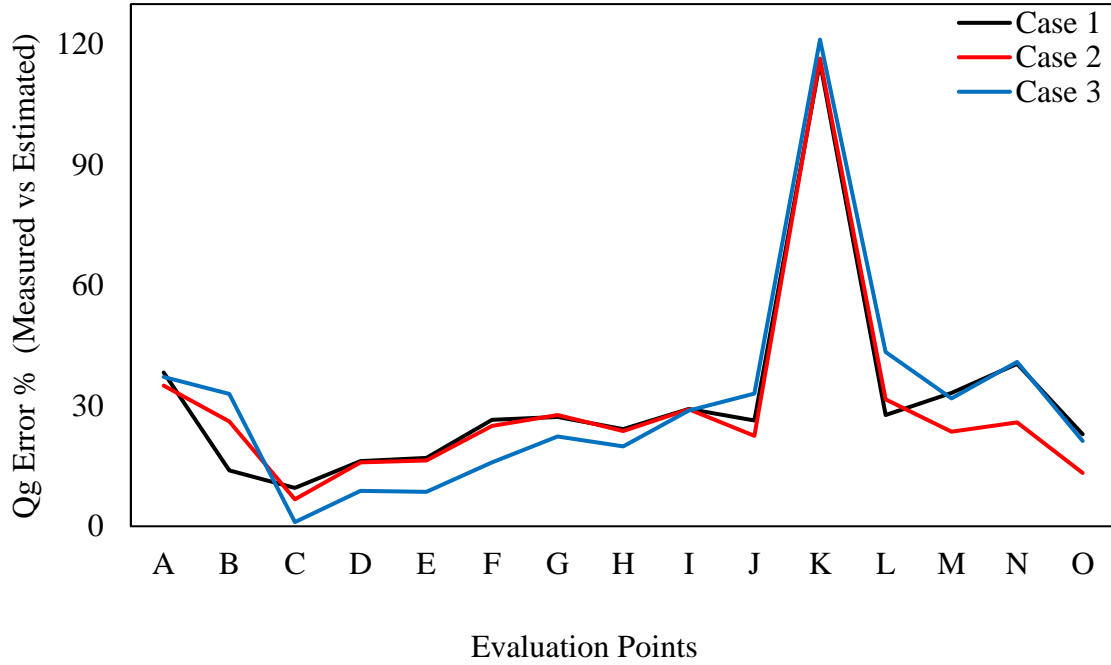

Figure 4.17 Error percentage for predicted gas flow rates for evaluation points A through for cases 1,2,3

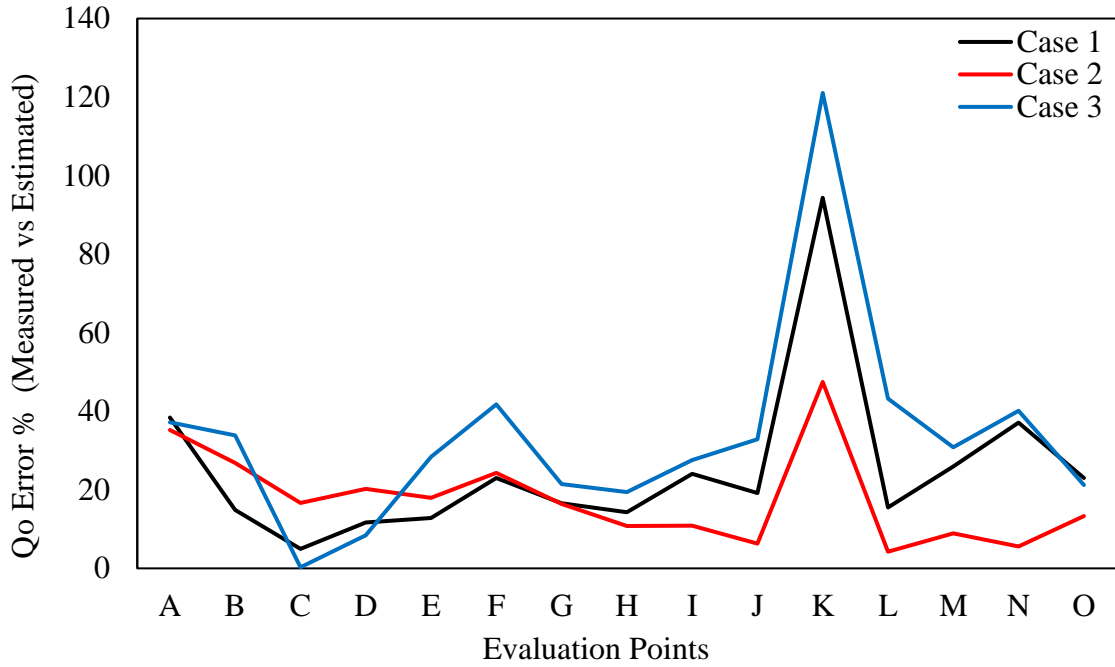

Figure 4.18 Error percentage for predicted oil flow rates for evaluation points A through O for cases 1,2,3

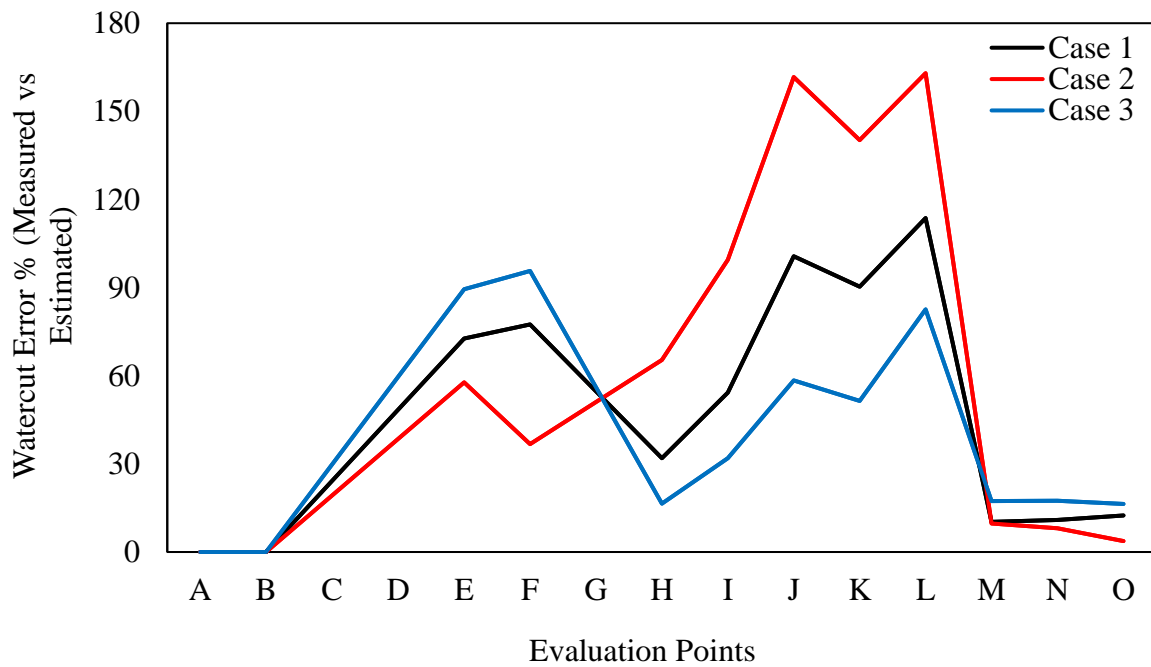

Figure 4.19 Error percentage for predicted water flow rates for evaluation points A through O for cases 1,2,3.

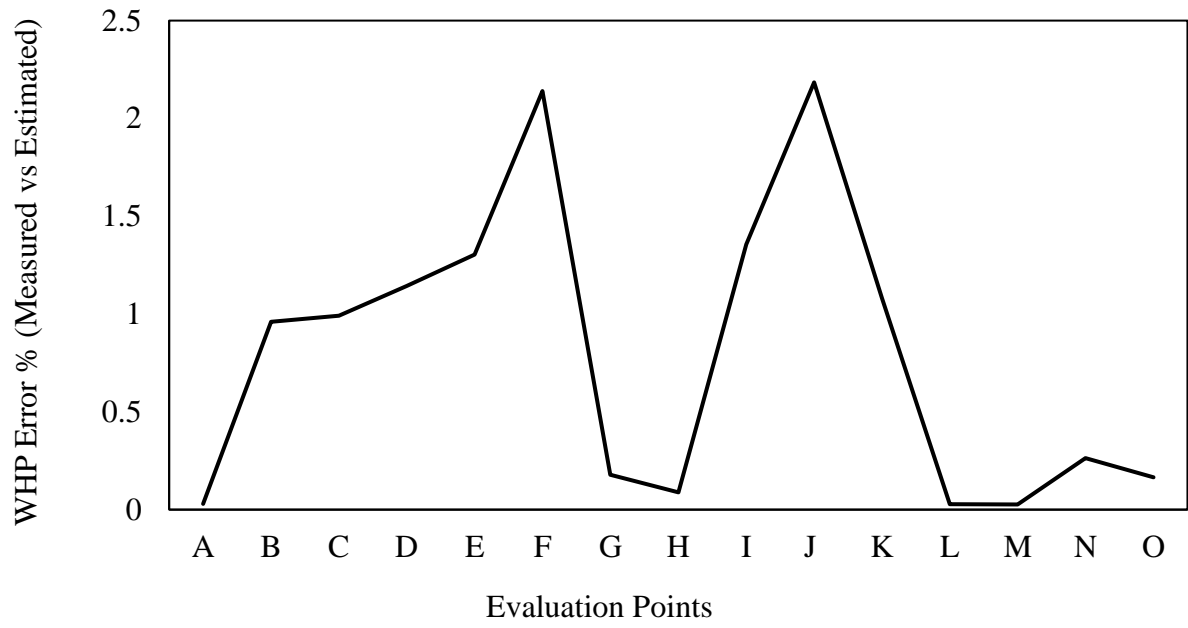

Figure 4.20 Error percentage for wellhead pressure matching for predicted gas & oil flow rates for case 3

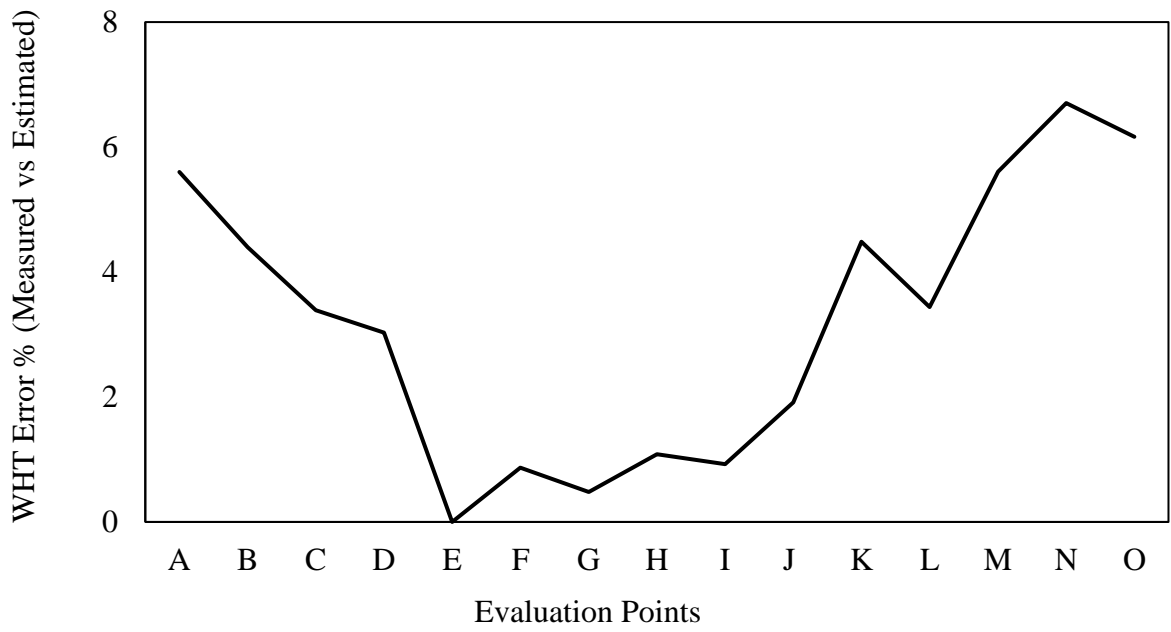

Figure 4.21 Error percentage for wellhead temperature matching for predicted gas & oil flow rates for case 3

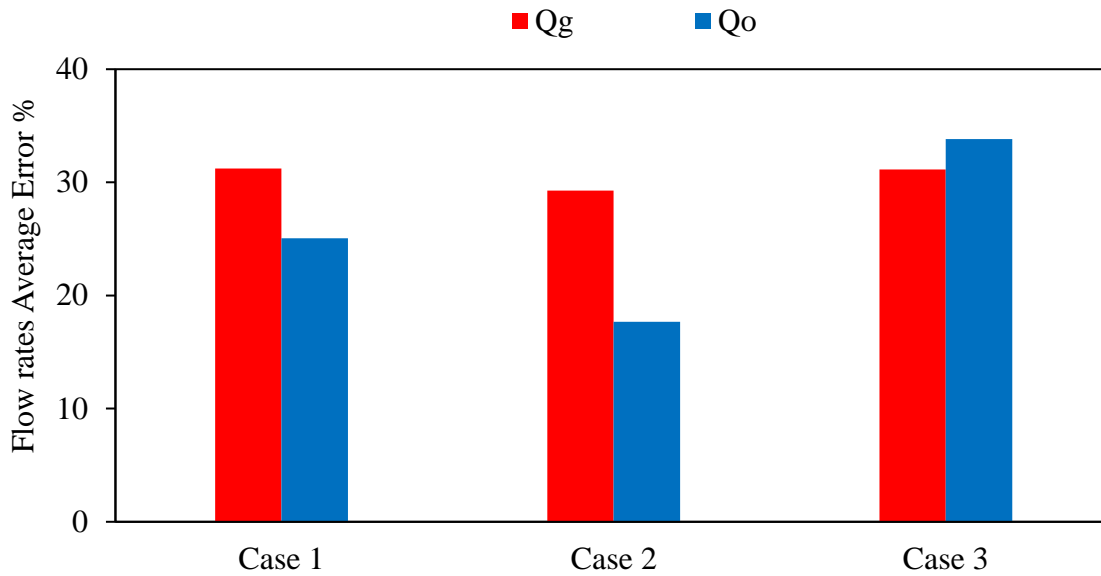

Figure 4.22 Average error percentage for gas and oil flowrates for cases 1,2,3

4.4 Tuning Case Results

In the three previous cases (1, 2, and 3), flow rates of oil, gas and water were estimated without using measured flow rates to tune the VFM model. The objective of these cases were to evaluate the performance of the PIPESIM model as a VFM model in flow rate prediction by using only measurement points of pressure and temperature, and also select the most appropriate set of choke correlations for our data set. The mechanistic choke correlations are most appropriate in comparison to the Gilbert correlations based on the results for the previous three cases.

The second part of this study has the objective of investigate the effect of given flow rates to tune the VFM model and analyze the potential benefits of providing few flow rate measurement points to enhance future flow rate estimations. As an example of VFM model, PIPESIM software can use some tuning parameters to adjust the flow models to better fit measured data. Tuning parameters can be fluid properties, flow correlation correction factors, correction on the friction factor and liquid holdup. For the tuning cases 4, 5, and 6, some flow rates from early time, mid

and late time production are provided as input data. The provided flow rate data are used in the VFM simulations to tune the model. The tuning simulations are carried out in three different cases.

The tuning cases were defined as follows:

1. Case 4: Three points oil and gas flow rates are given from early production history data (points A, B, C). The flow model is tuned by using these three flow rates.
2. Case 5: Oil and gas flow rates are provided for other two points from mid time production history data (points G and H). The objective of this case is to improve on prior estimates (points D, E, F) and fine tune model to improve future predictions.
3. Case 6: Measured water cut are provided for late production history data (last 3 points, M, N, O). The objective is to evaluate the combined effect of water cut and GOR on fine tuning flow rates predictions.

4.4.1 Case 4-Three points of oil and gas flow rates, all points of GOR and two points of water cut

In this case, the network model consists of five components also: i) IPR, ii) wellbore, iii) choke, iv) flowline, and iv) fluid model. The flow rates of three points from the early production history are disclosed to tune the model. The actual values of GORs are provided for all points. Table 4.6 shows the given information to perform the flow rates predictions. The given data in this table is the same as in Case 3, but it also includes the addition of three points of oil and gas flow rates (A, B, C).

Table 4.6 Tuning case 1 input data

Eval. Points	Allocated Gas (Mmcf/d)	Allocated Oil (Bbl/d)	Allocated Water (Bbl/d)	Allocated Liquid (Bbl/d)	GOR (scf/s tb)	Water Cut (%)	BHP (psi)	BHT (F)	WHP (psi)	WHT (F)	Upstream of choke temp (F)	Choke (/64ths)	Downstream of choke pressure (psi)	Downstream of choke Temp (°F)
A	X	X			X	X	X	X	X	X		X	X	
B	X	X			X	X	X	X	X	X		X	X	
C	X	X			X		X	X	X	X		X	X	
D					X		X	X	X	X		X	X	
E					X		X	X	X	X		X	X	
F					X		X	X	X	X		X	X	
G					X		X	X	X	X		X	X	
H					X		X	X	X	X		X	X	
I					X		X	X	X	X		X	X	
J					X		X	X	X	X		X	X	
K					X		X	X	X	X		X	X	
L					X		X	X	X	X		X	X	
M					X		X	X	X	X		X	X	
N					X		X	X	X	X		X	X	
O					X		X	X	X	X		X	X	

Procedure for manual estimation of flow rates: The procedure used to estimate flow rates in Case 4 is the same as for Case 2. The only difference is that in this current case we will use given (measured) oil and gas flow rate to tune the model. In PIPESIM there are a few options to tune the model. As PIPESIM was not originally designed as a VFM model, we manually tune some of these options to match pressures, temperatures and given flow rates. In our simulations, the following parameters were tuned to match the given data:

- Stock tank fluid properties are tuned such as API gravity, Gas specific gravity, water specific gravity.
- Three points flow rates that are disclosed from early production time.

Different combinations of choke correlations are used for critical and subcritical flow. Different correlation combinations provided different flow rate predictions. Different wellbore model correlations are examined as well, but no significant change in flow rate predictions were observed.

Since the GOR values are disclosed, different reservoir pressures from IPR model are used to match bottomhole pressures. The given productivity index ($PI = 0.715$ liquid bbl/day/psi) was kept constant for all the points. Water cut was used to match the wellhead temperatures and pressures. Therefore, by matching the wellhead and bottomhole pressures with the actual measured pressures, the flow rates are predicted. Figure 4.23 and 4.24 show the percentage error for the tuning point A, B, C for gas and oil rates, using different combinations of subcritical and critical flow correlations/models for the choke. Since three subcritical and eight critical models were available for the choke, a set of 24 different possible flow rates were obtained for evaluations points A, B and C. Hence, the combination which gives the least error summation for the three evaluations points would be picked as the most accurate set of correlation for the choke model.

In both figures 4.23 and 4.24, Mechanistic- Mechanistic choke correlation shows the least error percentage. Figure 4.25 shows the cumulative errors (points A+B+C) for gas and oil flow rates for different pair of choke correlations. As it is clear from figure, there are two choke correlation pairs in this figure that show low cumulative errors (Mechanistic- Mechanistic and Ashford-Ashford). Mechanistic- Mechanistic is selected as the appropriate choke correlations, since Ashford-Ashford is not appropriate for our data set. Because Ashford correlation predicts well for actual flow rates less than 2,000 stb/d. At higher flow rates, the Ashford correlation tends to underpredict flow. Our data set have flow rates higher than 2000 stb/d.

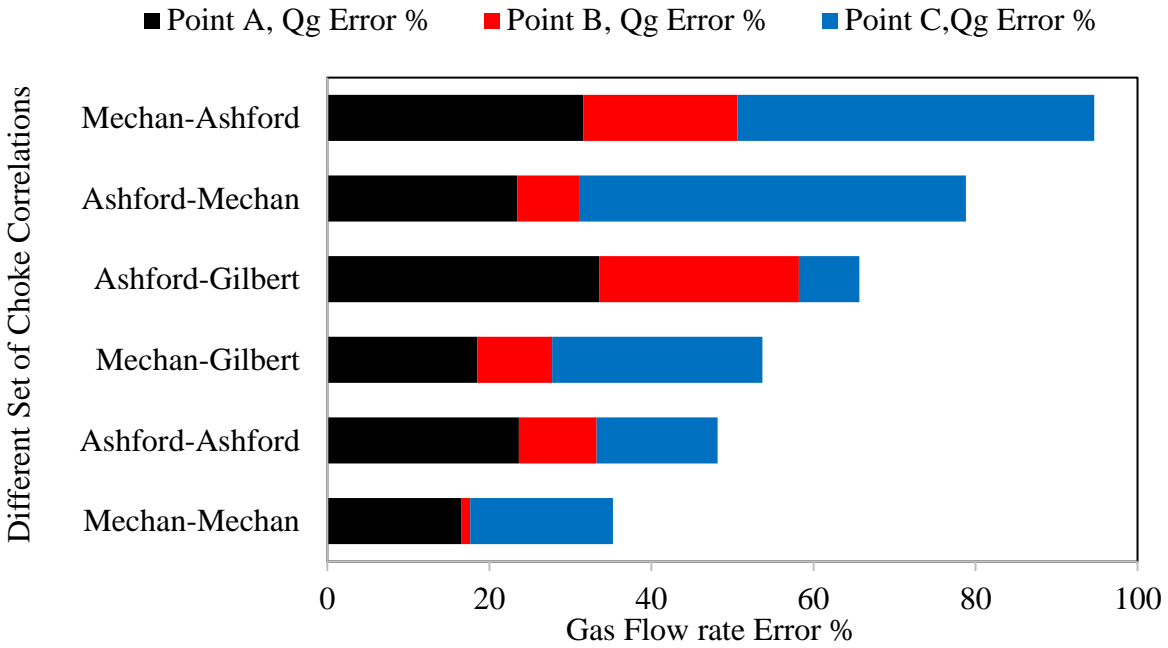

Figure 4.23 Gas flow rate error percentage vs different choke correlations

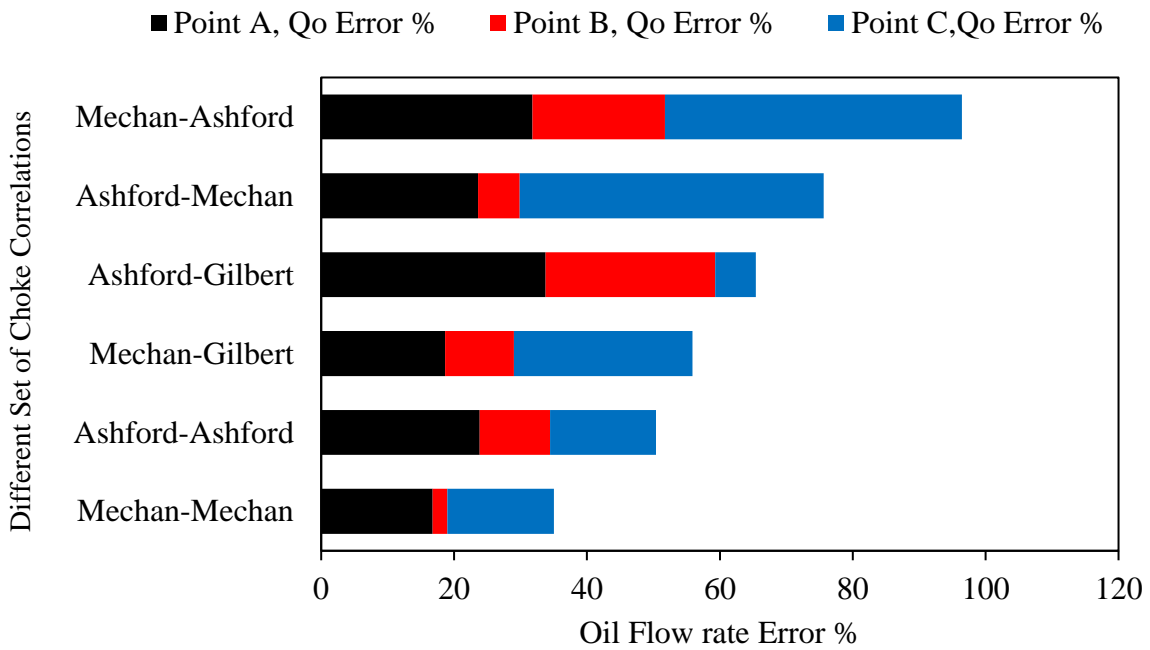

Figure 4.24 Oil flow rate error percentage vs different choke correlation

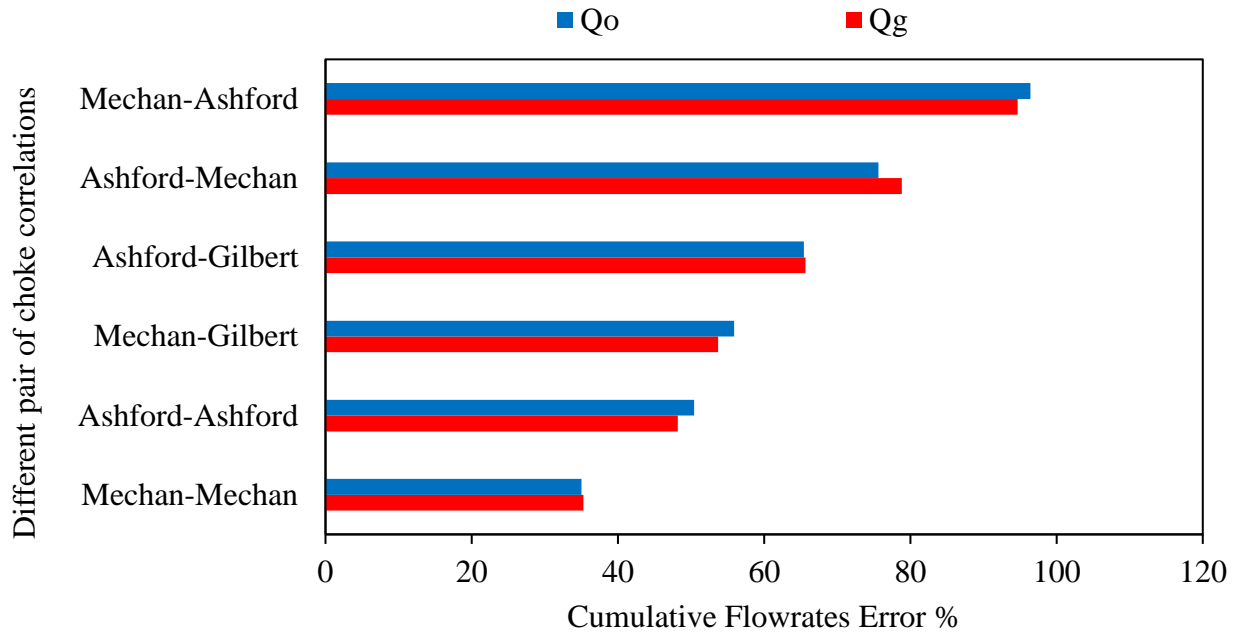

Figure 4.25 Cumulative error percentage (points A+B+C) for gas and oil flow rates for different pair of choke correlations

In order to confirm the selection of mechanistic based correlations for the choke, a comparative study was performed between set of correlations that showed in Figure 4.25.

Figure 4.25 show the results for this comparative study for the choke model using the given dataset. As can be seen in the figure, there is a considerable difference in flow rate predictions by choosing Mechanistic-Mechanistic type of choke correlations rather than other correlations. We believe that the choke correlations (mechanistic and mechanistic) should provide better results when compared to the actual flow rates, since the models for mechanistic and mechanistic are recommended for a wider range of conditions, and can be applied to sub-critical and critical conditions.

Figures 4.26 and 4.27 show the final results for the estimation of oil, gas flow rates for Case 4 after the manual tuning for the choke correlation and fluid properties. As figures 4.26 and 4.27 show, the flow rate error percentage decreased significantly for Case 4. Three gas and oil

flowrate points from early production history of the well are provided into the model as input data and the model is tuned carefully. The model prediction results improved significantly as it is clear in figure 4.31. The average error percentage of flow rates are plotted for each case in figure 4.31. The plot indicates that, the disclosed flow rates considerably improved the model flow rate prediction. Figure 4.28 shows the watercut error percentages. Still, there is a large error percentage from point D to point L. In practice, these large errors on water flow rate prediction would indicate malfunction of the flow meter. In fact, the operator which provided the field data for this study confirmed that after point L, the water flow meter was re-calibrated, and the previous measurements (between points D and L) probably have erroneous measurements due to flow meter malfunction. Figures 4.29 and 4.30 show the wellhead pressure and temperature error percentage between measured and estimated data. The average errors are mostly between 2%-5% for both figures, which indicate that there is a reasonable and acceptable match between estimated and measured pressure and temperature data while predicting the flowrates of the cases with the model.

Table 4.7 Fluid properties tuned for case 4

Tuning Parameters	Tuning Values
API	32.7
Gas specific Gravity	0.5
Water Specific Gravity	0.94

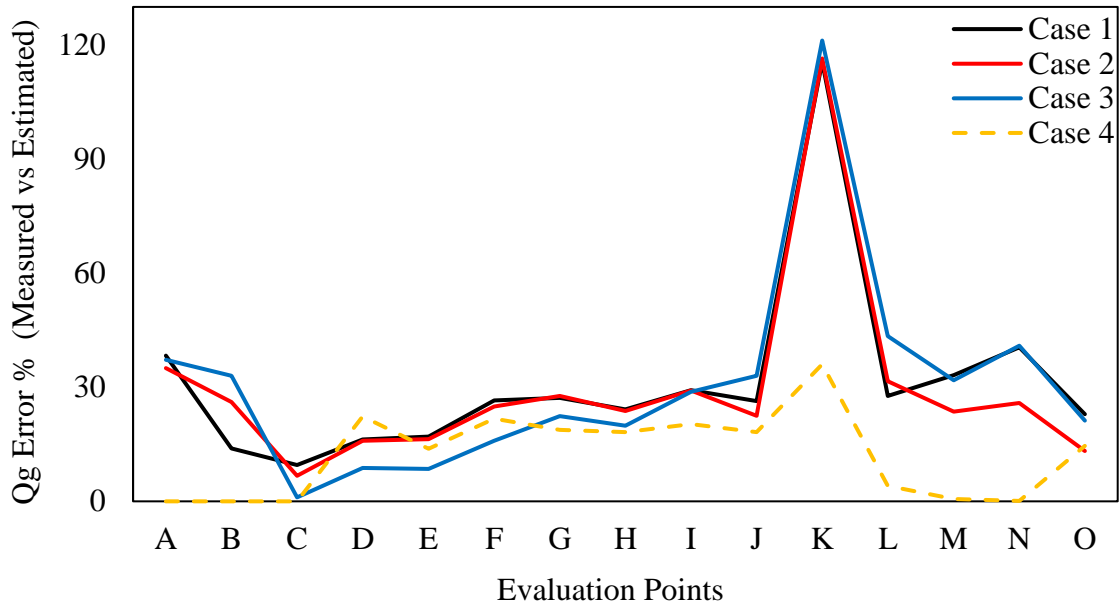

Figure 4.26 Error percentage for predicted gas flow rates for evaluation points A through O for cases 1~4

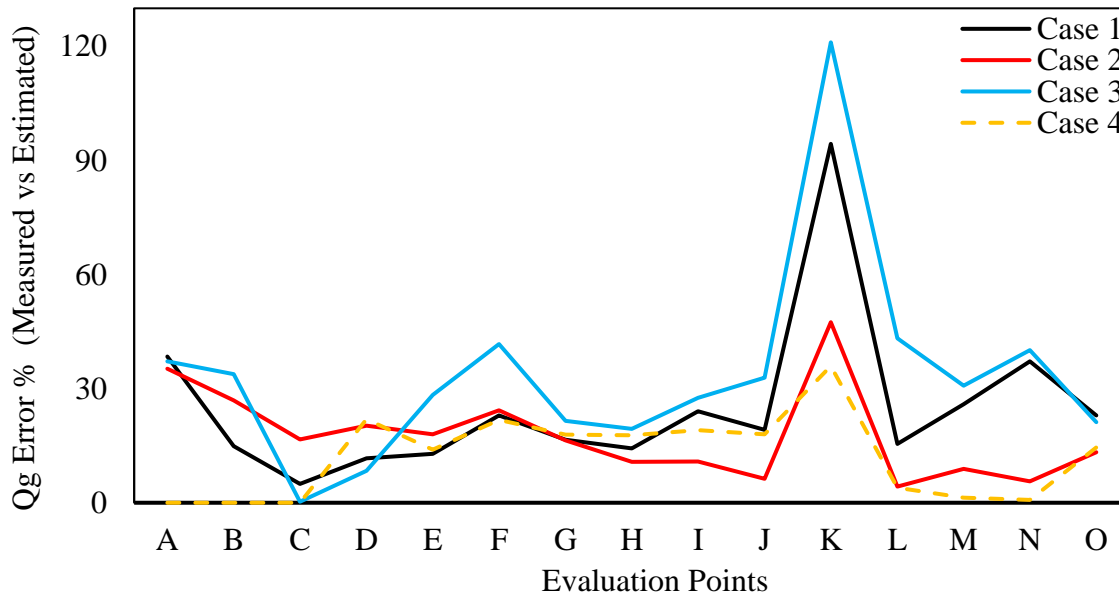

Figure 4.27 Error percentage for predicted oil flow rates for evaluation points A through O for cases 1~4

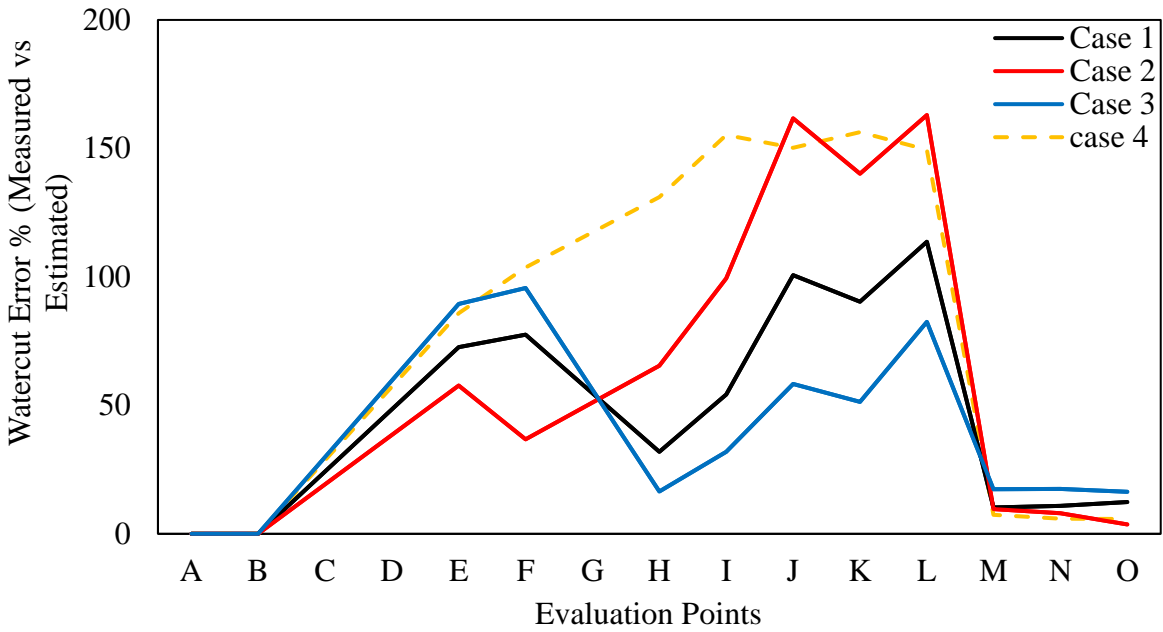

Figure 4.28 Error percentage for predicted oil flowrates for evaluation points A through O for case 4

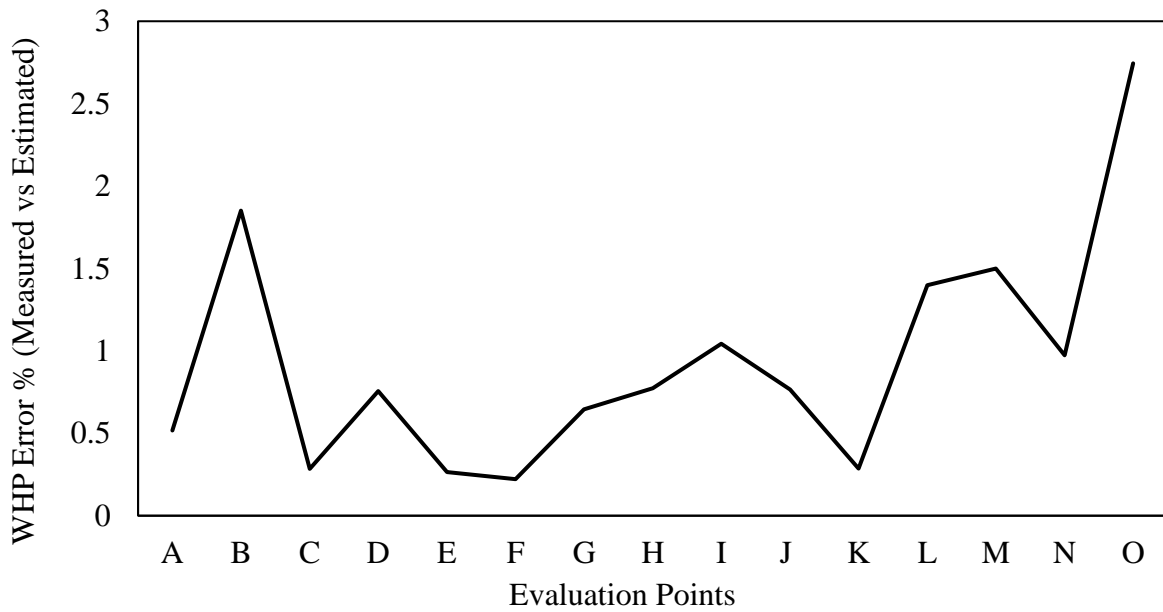

Figure 4.29 Error percentage for wellhead pressure matching for predicted gas & oil flow rates for case 4

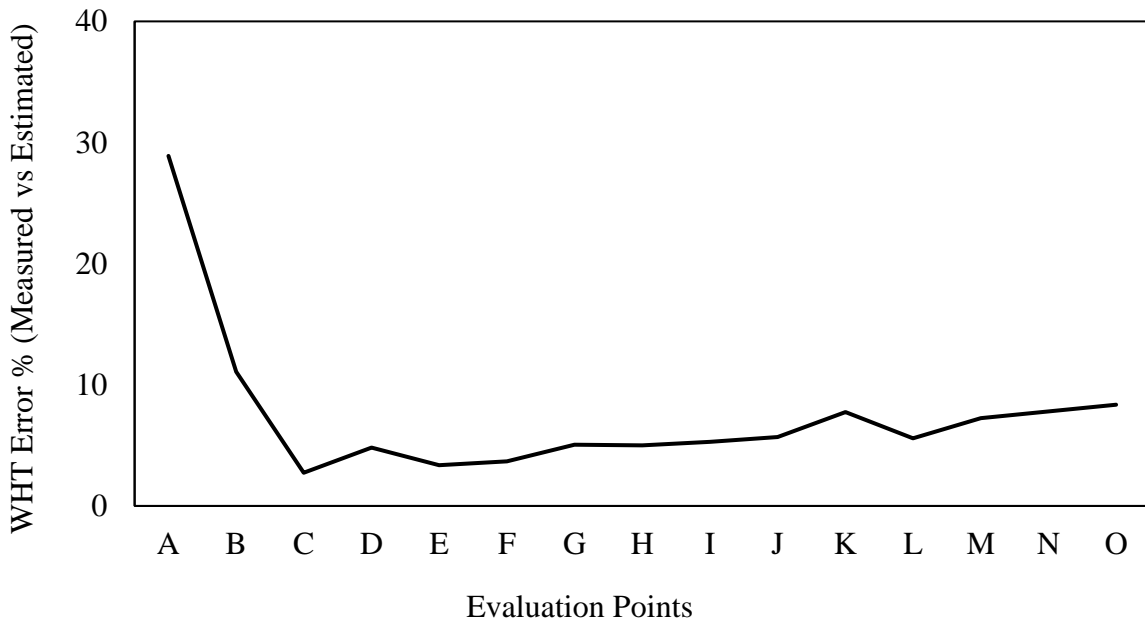

Figure 4.30 Error percentage for wellhead temperature matching for predicted gas & oil flow rates for case 4

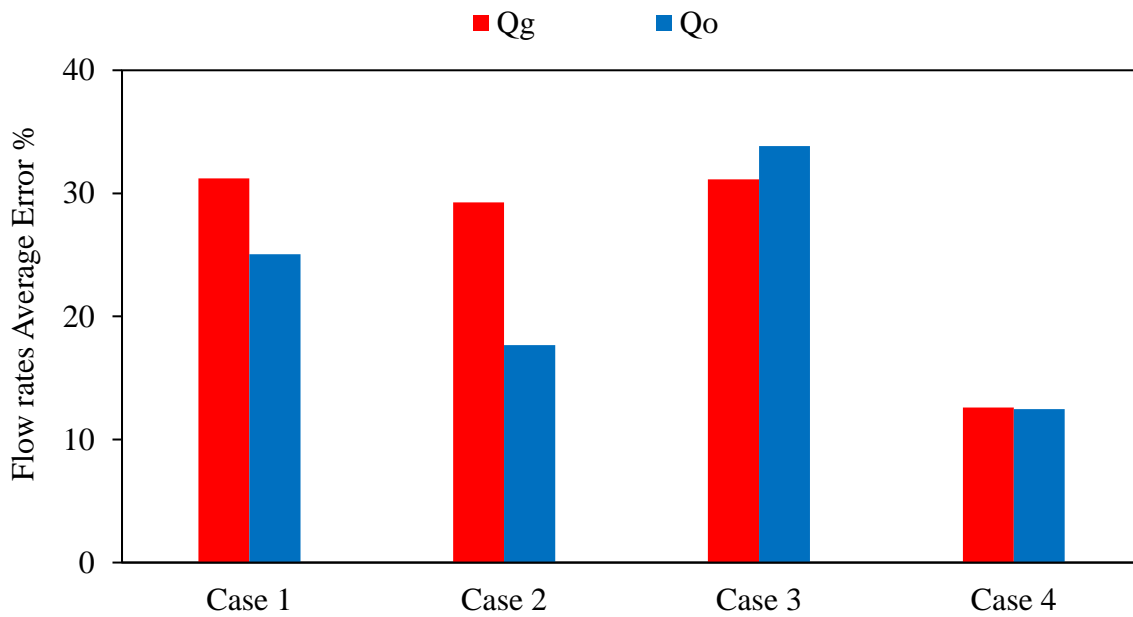

Figure 4.31 Average error percentage for gas and oil flowrates for cases 1~4

4.4.2 Case 5-five points of oil and gas flow rates, all points of GOR and two points of water cut

Oil and gas flow rates are disclosed from mid-time production of flow data for this case.

The objective of this case is to improve the flow rate prediction of the early time of production and also find a better tuned model to provide better future prediction. Table 4.8 shows three points (A, B, C) from early production and two points (G, H) from mid time production which are provided to re-tune the VFM model and provide more accurate predictions.

Table 4.8 Tuning case 5 input data

Eval. Points	Allocated Gas (Mmcf/d)	Allocated Oil (Bbl/d)	Allocated Water (Bbl/d)	Allocated Liquid (Bbl/d)	GOR (scf/s tb)	Water Cut (%)	BHP (psi)	BHT (F)	WHP (psi)	WHT (F)	Upstream of choke temp (F)	Choke (/64ths)	Downstream of choke pressure (psi)	Downstream of choke Temp (°F)
A	X	X			X	X	X	X	X	X		X	X	
B	X	X			X	X	X	X	X	X		X	X	
C	X	X			X		X	X	X	X		X	X	
D					X		X	X	X	X		X	X	
E					X		X	X	X	X		X	X	
F					X		X	X	X	X		X	X	
G	X	X			X		X	X	X	X		X	X	
H	X	X			X		X	X	X	X		X	X	
I					X		X	X	X	X		X	X	
J					X		X	X	X	X		X	X	
K					X		X	X	X	X		X	X	
L					X		X	X	X	X		X	X	
M					X		X	X	X	X		X	X	
N					X		X	X	X	X		X	X	
O					X		X	X	X	X		X	X	

The VFM model in Case 5 is tuned based on fluid properties and choke correlations like the previous cases 1 to 4. The error percentage of the flow rates are calculated compared to the choke correlations. The error percentage results are plotted in figures 4.28-4.30 for the given five points of gas and oil flow rates. As can be seen from Figure 4.32 and 4.33, Mechanistic-Mechanistic correlation shows the lowest error percentage. As concluded in the previous cases,

mechanistic based model appears to have a better match for the dataset given in this study. Figure 4.34 which shows the cumulative percentage error also confirms the lowest error for Mechanistic-Mechanistic correlation. The final results for the flow rate estimations after the selection of the choke models and tuning fluid properties are shown in Figures 4.35 and 4.36. As can be seen in these figures, the flow rate estimation improved for both oil and gas flow rates and it is considerable difference between Case 4 and Case 5. This result is an indication that whenever we added more tuning points and provided more measured flow rates points into the model, the error percentages decreased significantly and flow rate predictions improved strongly. Figure 4.40 shows that the average error percentage for Case 5 is dropped to half (about 6%) in comparison with Case 4 (about 12%). This is due to the disclosing of 5 flow rate points into flow model from early and mid-time of production history.

Table 4.9 Fluid properties tuned for case 5

Tuning Parameters	Tuning Values
API	27.5
Gas specific Gravity	0.6
Water Specific Gravity	1.1

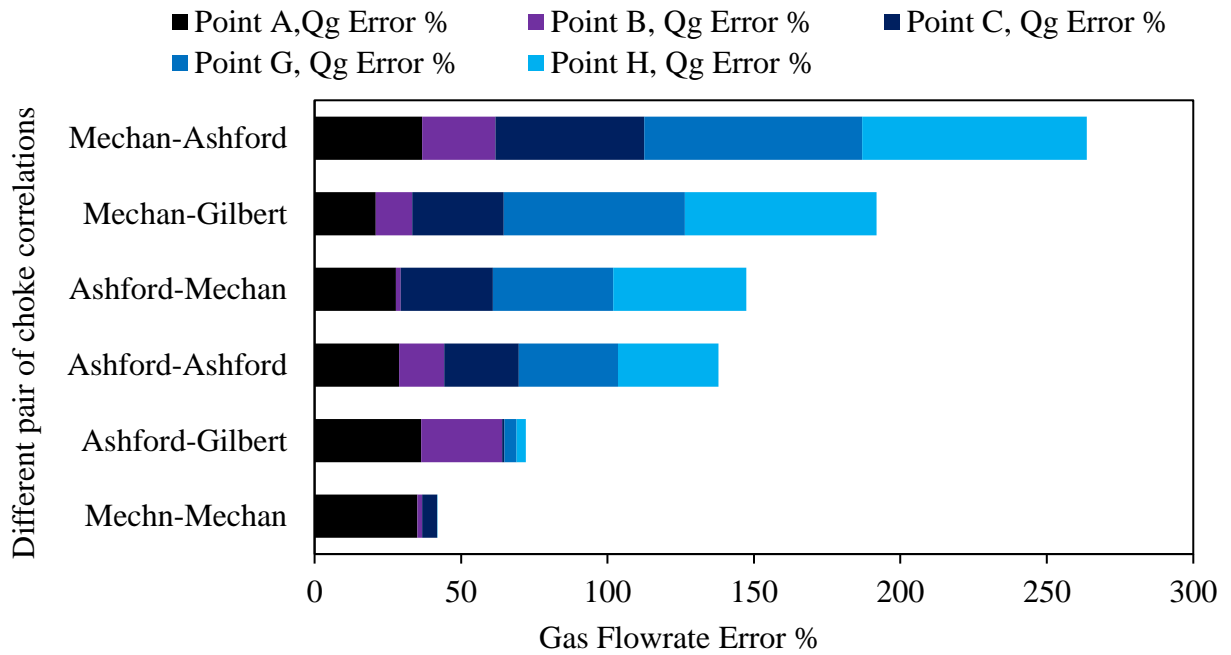

Figure 4.32 Gas flow rates error percentage vs different choke correlations for five points (A+B+C+G+H)

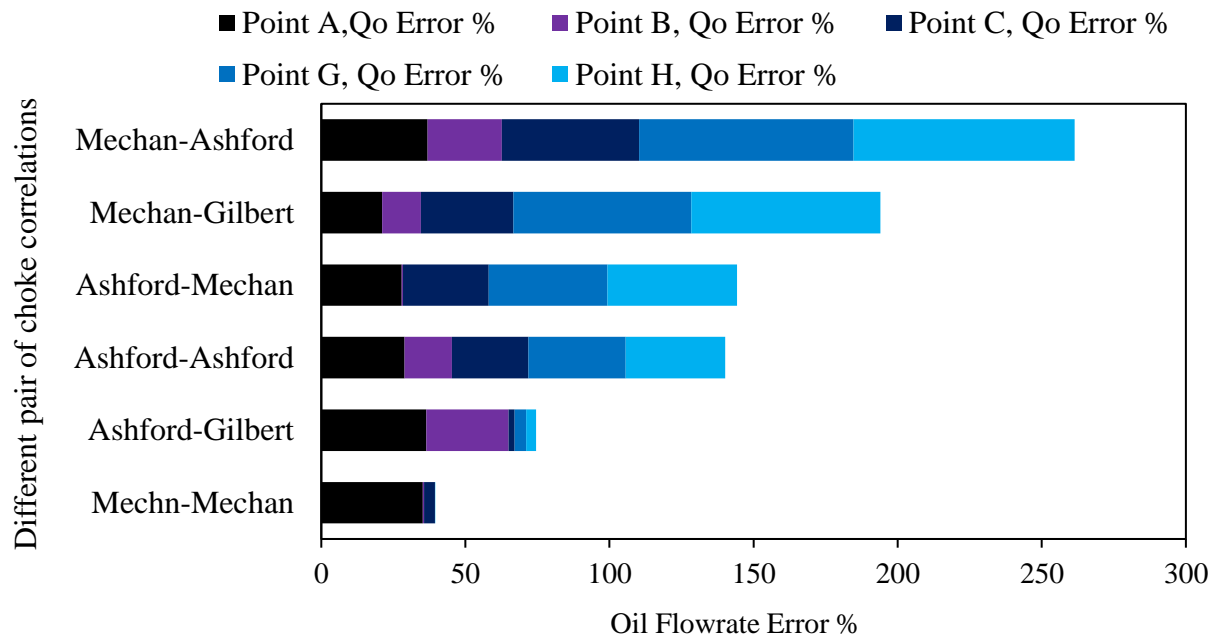

Figure 4.33 Oil flow rates error percentage vs different choke correlations for five points (A+B+C+G+H)

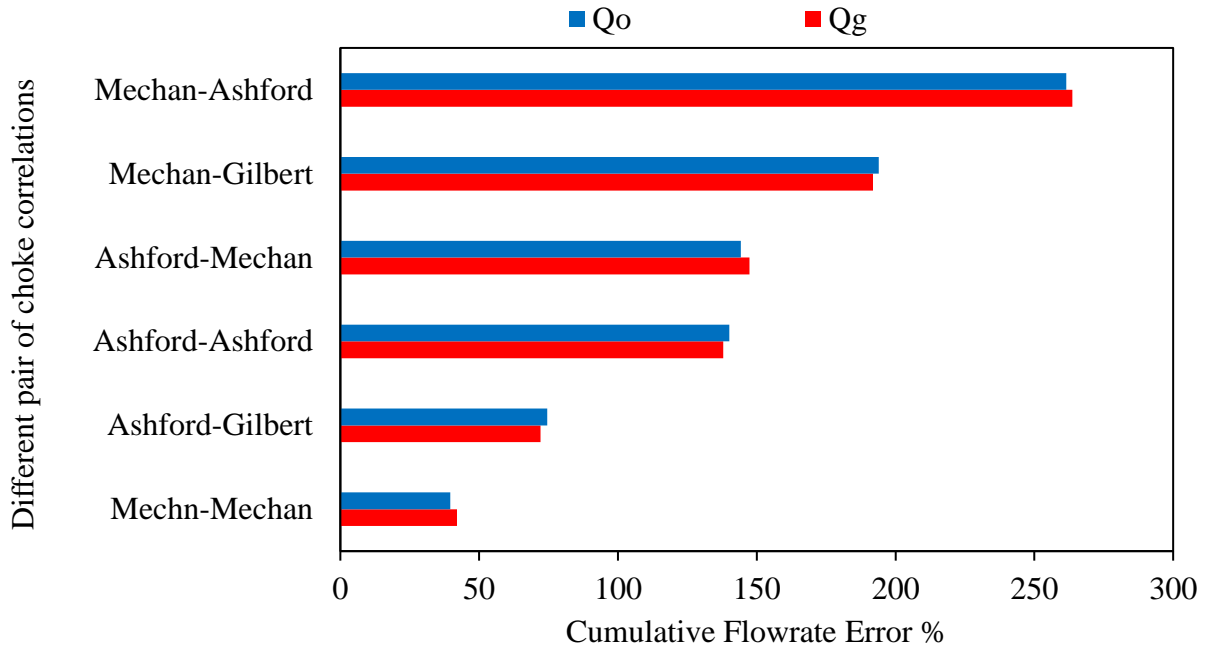

Figure 4.34 Cumulative error percentage for gas and oil flow rates vs different choke correlations for five points (A+B+C+G+H)

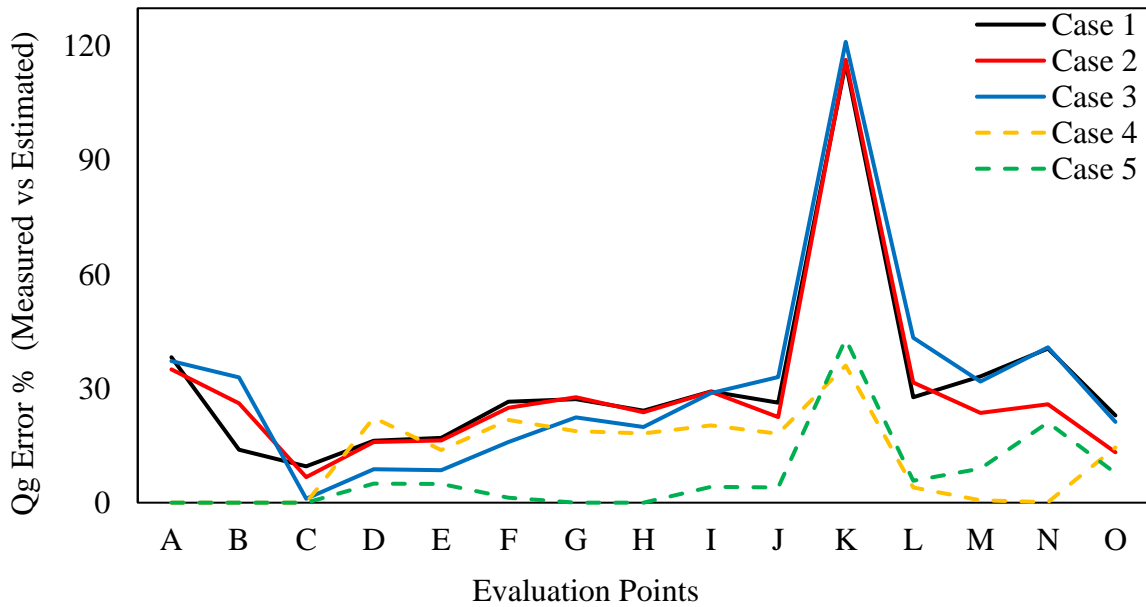

Figure 4.35 Comparison of gas flow rates error percentage for cases 1~5

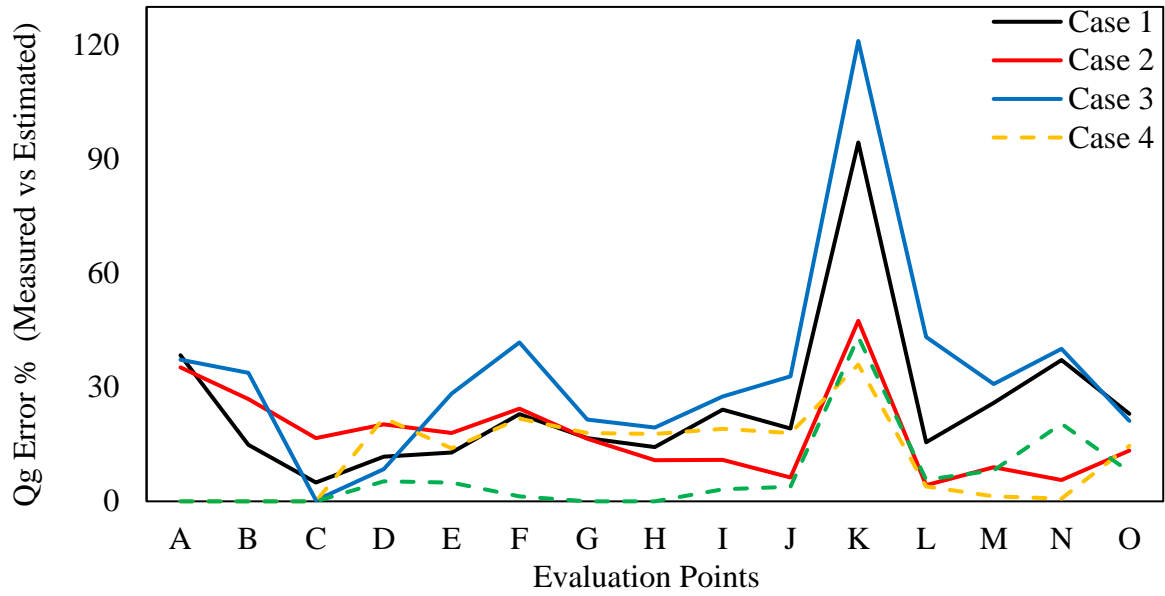

Figure 4.36 Comparison of oil flow rates error percentage for cases 1~5

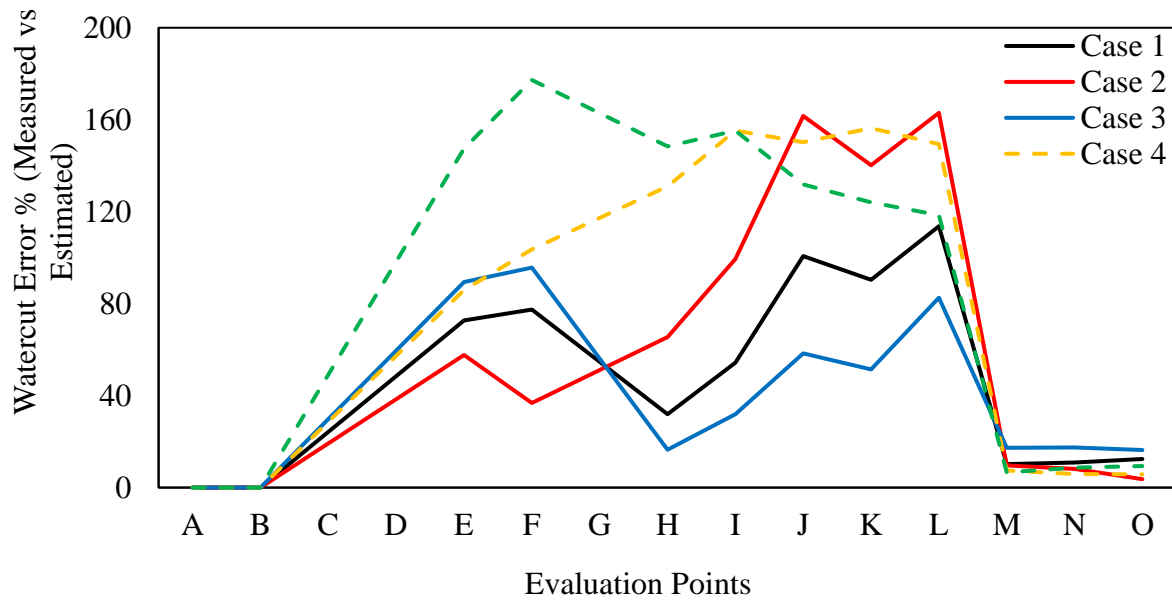

Figure 4.37 Comparison of water flow rates error percentage for cases 1~5

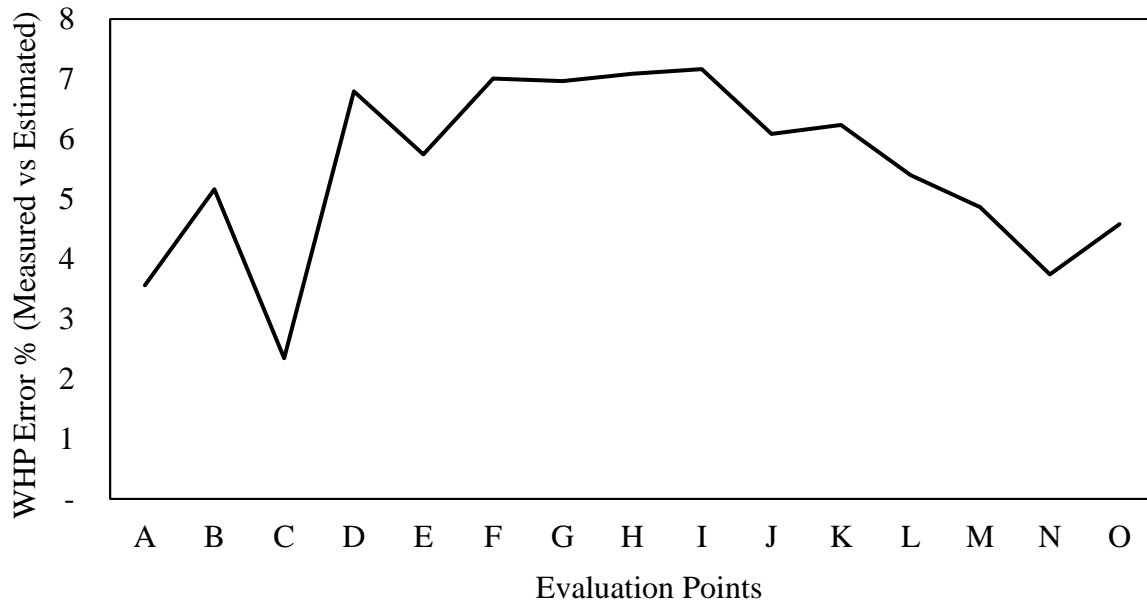

Figure 4.38 Error percentage for wellhead pressure matching for predicted gas & oil flow rates for case 5

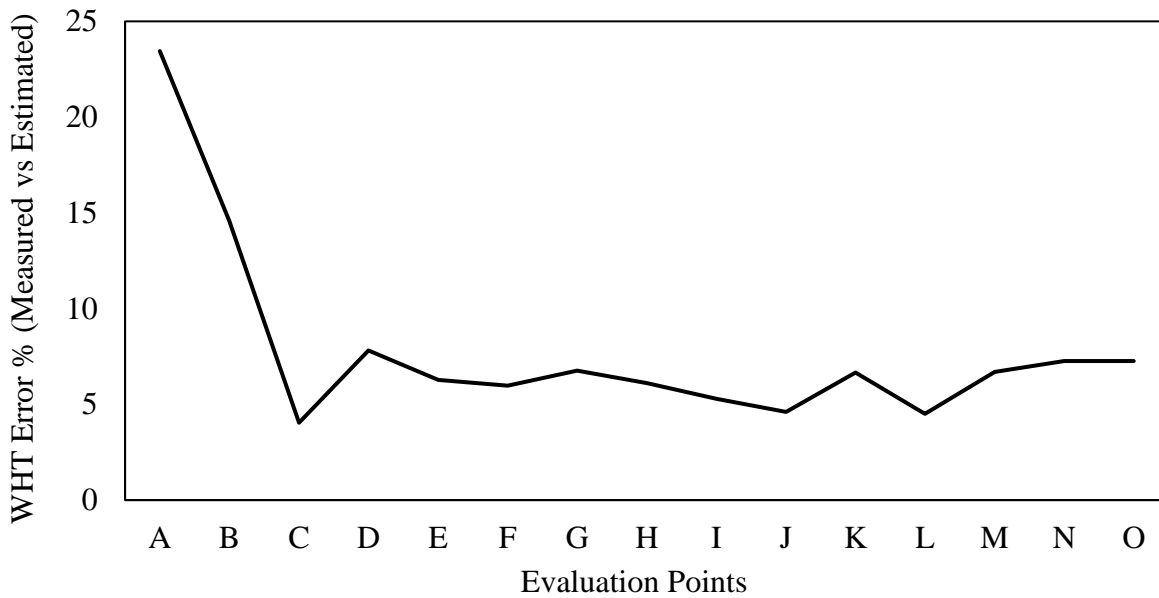

Figure 4.39 Error percentage for wellhead temperature matching for predicted gas & oil flow rates for case 5

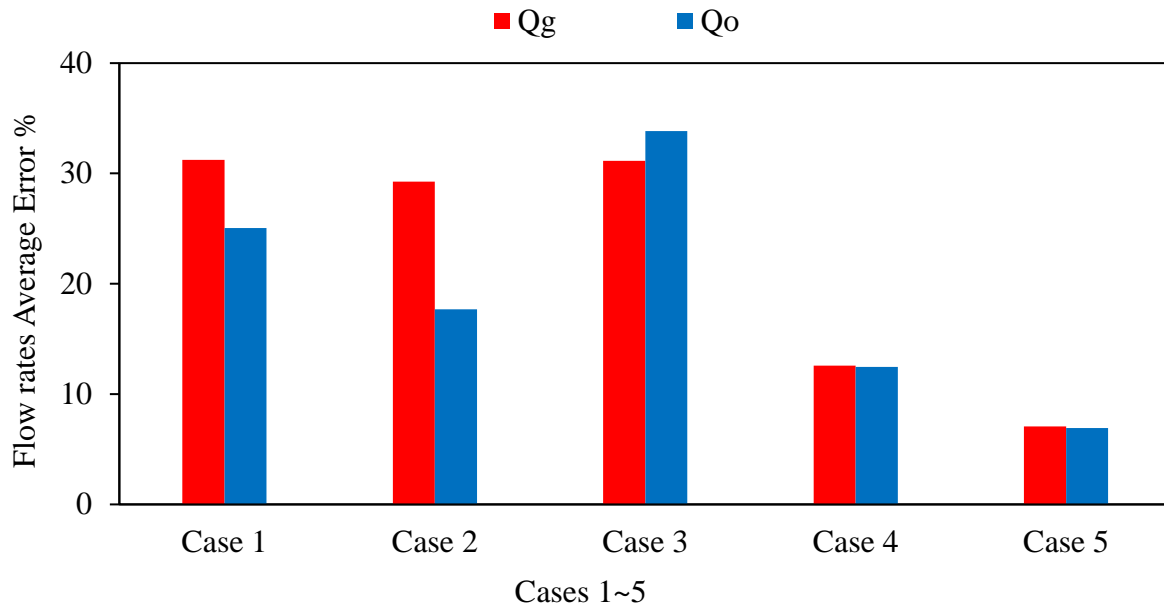

Figure 4.40 Average error percentage for gas and oil flowrates for cases 1~5

4.4.3 Case 6- Five points of oil and gas rates, all points of GOR and five points of Water Cut

In this case, measured water cuts are provided from late production data, as shown in Table 4.10. The objective of the case is to evaluate the combined effect of water cut and GOR on fine tuning flow rates predictions. Water cuts are provided as additional input data in flow model.

Table 4.10 Tuning case 6 input data

Eval. Points	Allocated Gas (Mmcf/d)	Allocated Oil (Bbl/d)	Allocated Water (Bbl/d)	Allocated Liquid (Bbl/d)	GOR (scf/s tb)	Water Cut (%)	BHP (psi)	BHT (F)	WHP (psi)	WHT (F)	Upstream of choke temp (F)	Choke (/64ths)	Downstream of choke pressure (psi)	Downstream of choke Temp (°F)
A	X	X			X	X	X	X	X	X		X	X	
B	X	X			X	X	X	X	X	X		X	X	
C	X	X			X		X	X	X	X		X	X	
D					X		X	X	X	X		X	X	
E					X		X	X	X	X		X	X	
F					X		X	X	X	X		X	X	
G	X	X			X		X	X	X	X		X	X	
H	X	X			X		X	X	X	X		X	X	
I					X		X	X	X	X		X	X	
J					X		X	X	X	X		X	X	
K					X		X	X	X	X		X	X	
L					X		X	X	X	X		X	X	
M					X	X	X	X	X	X		X	X	
N					X	X	X	X	X	X		X	X	
O					X	X	X	X	X	X		X	X	

Table 4.10 shows the three points that are selected from production data for using as input data in flow model. The tuning is done for fluid properties and choke correlations. Like other two cases, the same choke correlations are used for this case. There is not a significant change in fluid properties tuning. Addition of three points WCs from late production data, did not affect the flow rate prediction significantly.

The estimated flow rate results are shown in figures 4.41 and 4.42. All cases are presented in these figures. There is a spike in evaluation points such as K that show differences larger than 50% when comparing gas oil flow rate prediction like other cases. This peak with high percentage error is due to boundary between the critical and subcritical flow of the choke, so there is a transition from choke critical flow to subcritical flow.

Case 6 is the last case which five flow rate points from early and mid-time production data are provided into flow model. In addition to flow rates, five points water cuts and all GOR are also

used in the model. Case 6 has the least error percentage of flow rates as it is clear in figures 4.41,4.42, and 4.46. The flow model is tuned by 5 flow rates data points from early time and mid-time production history, five water cut data, all GOR points and fluid properties. The flow rate error percentages are decreased considerably due to the tuned model such as Case 5.

The difference between Case 5 and Case 6 is the input data that are provided into model. Case 6 is same as Case 5 but three additional points of water cut from late production history are used as input data. Addition of three points WCs from late production data, did not affect the flow rate prediction significantly. Figures 4.44 and 4.45 show the wellhead pressure and temperature error percentage between measured and estimated data like previous cases. There is a reasonable and acceptable match between estimated and measured pressure and temperature data while predicting the flowrates of the cases with the model.

Table 4.11 Fluid properties tuned values for case 6

Tuning Parameters	Tuning Values
API	28.5
Gas specific Gravity	0.6
Water Specific Gravity	1.1

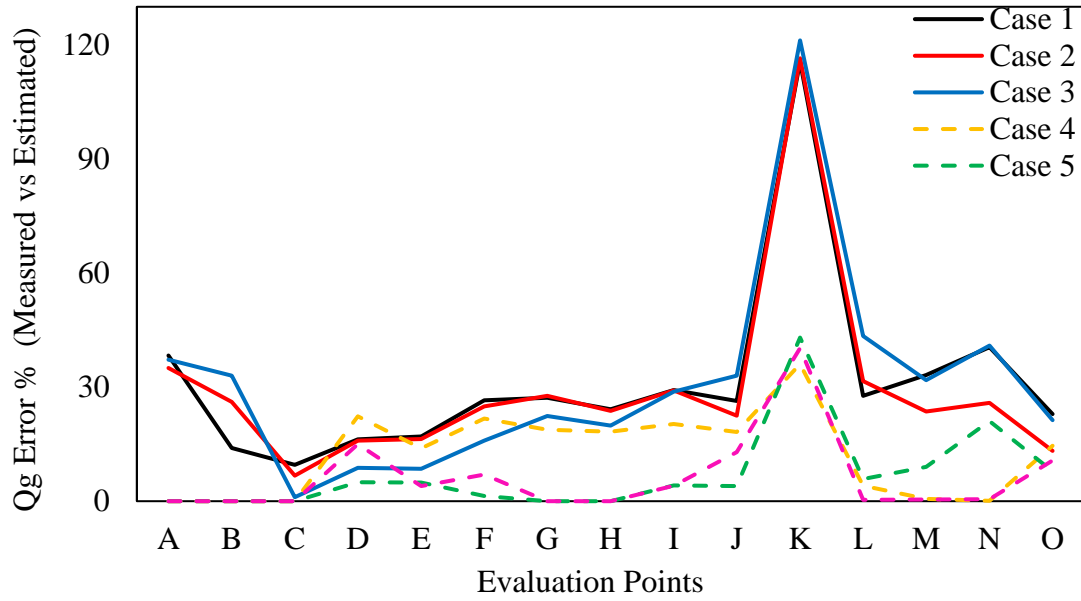

Figure 4.41 Comparison of gas flow rates error percentage for cases 1~6

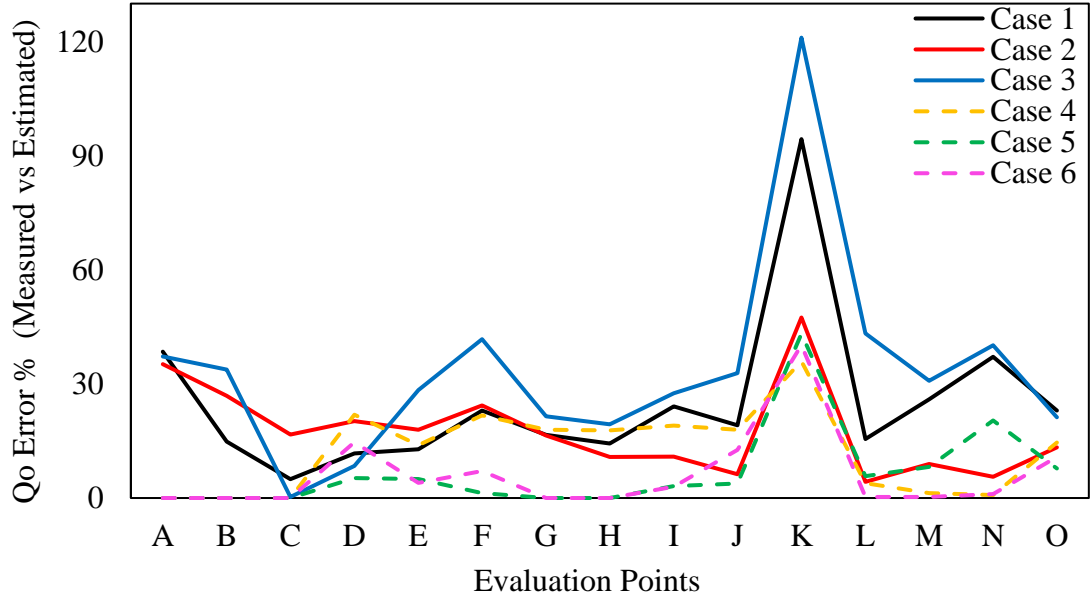

Figure 4.42 Comparison of oil flow rates error percentage for cases 1~6

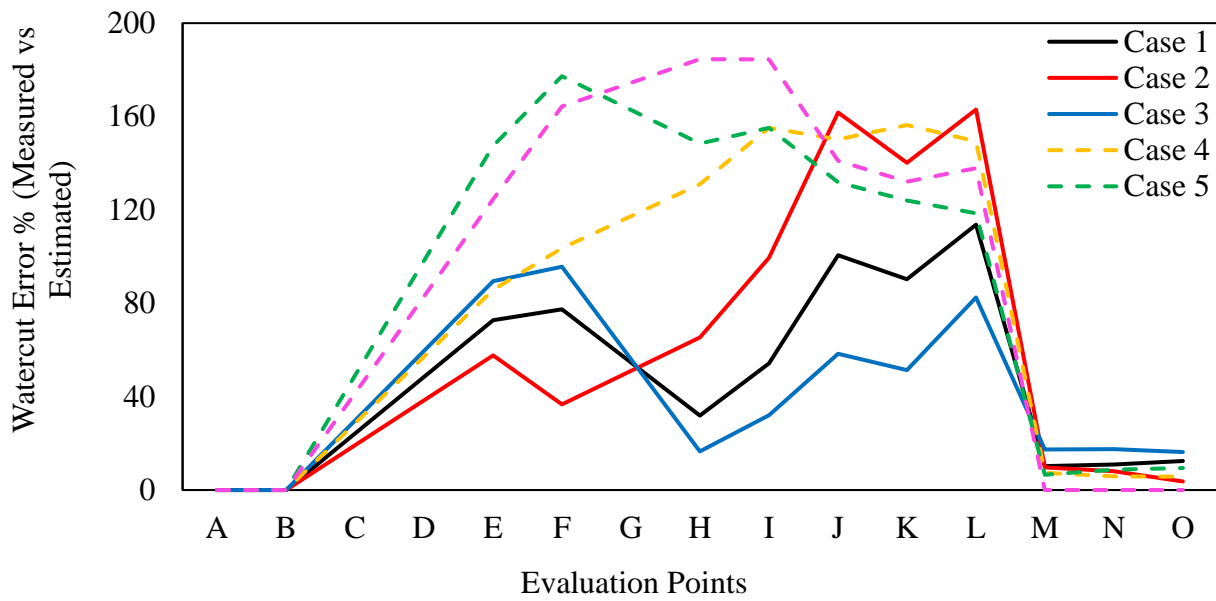

Figure 4.43 Comparison of water flow rates error percentage for cases 1~6

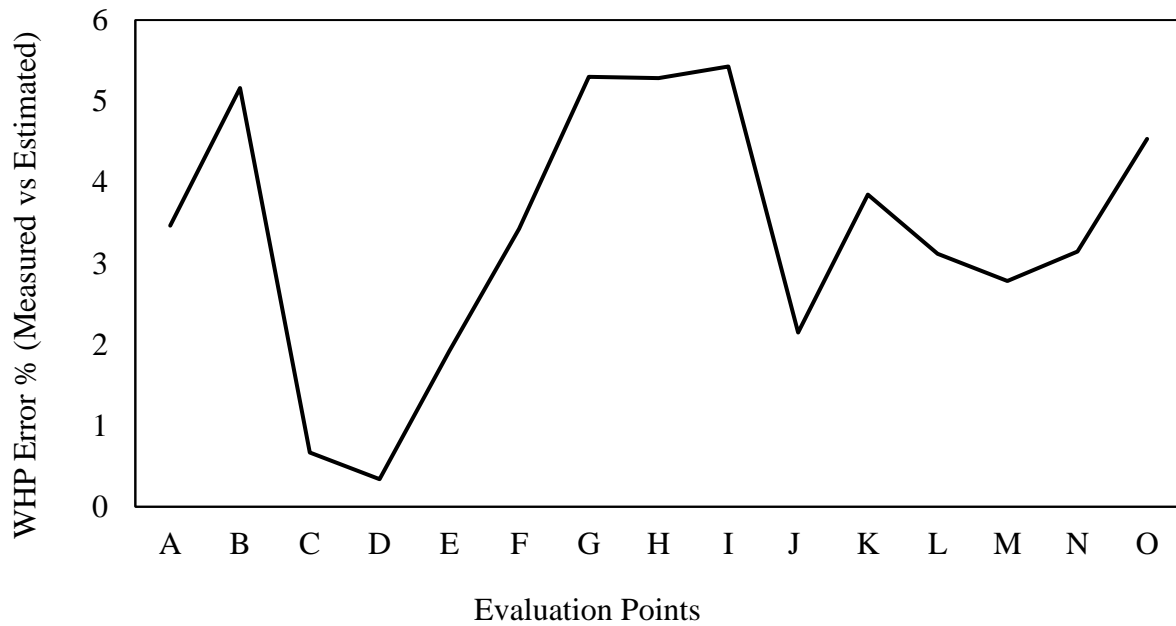

Figure 4.44 Error percentage for wellhead pressure matching for predicted gas & oil flow rates for case 6

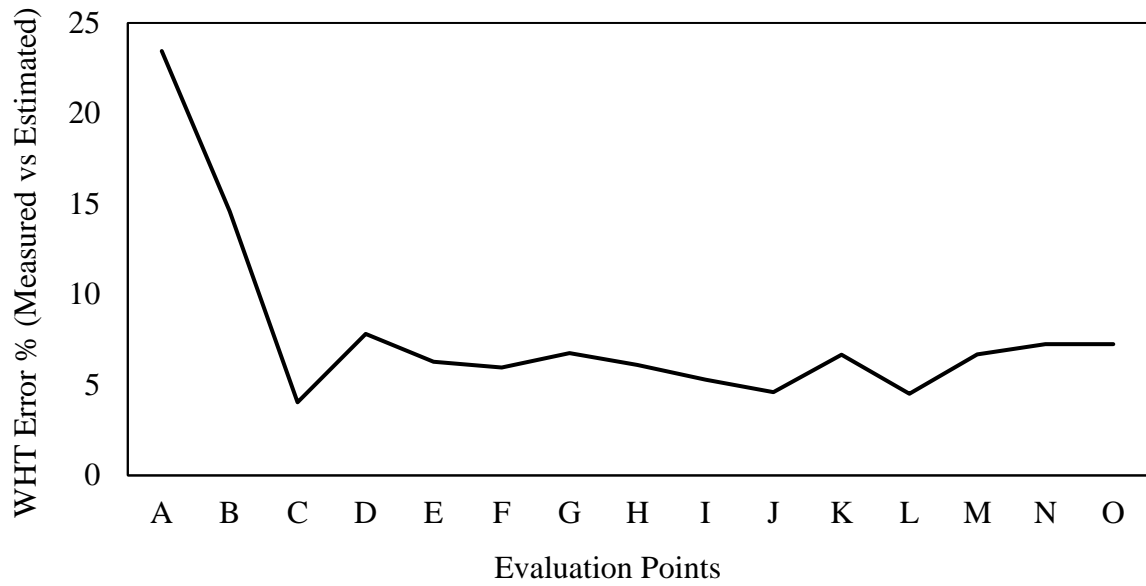

Figure 4.45 Error percentage for wellhead temperature matching for predicted gas & oil flow rates for case 6

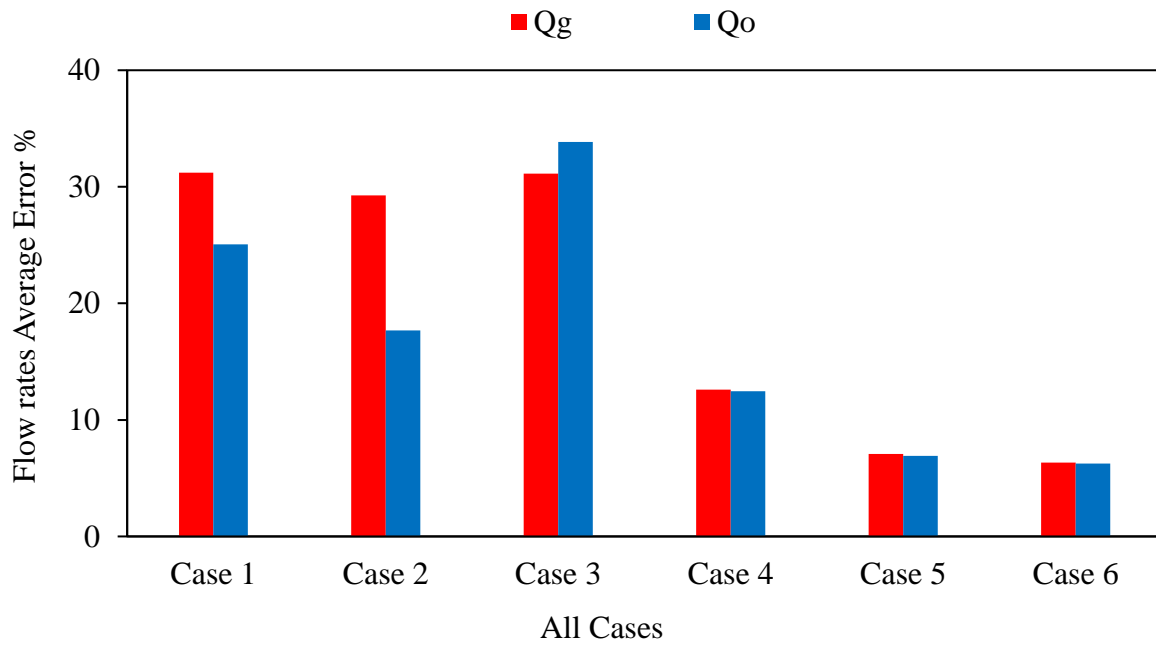

Figure 4.46 Average error percentage for gas & oil flow rates for all cases

4.5 Comparison of five different VFM commercial packages

The flow rate prediction of five different suppliers are compared with actual (measured) field data and with each other as well. The comparisons are carried out based on Case 6 input data, as this case have the most of the input data. Pipesim as one of the VFM suppliers is used in the simulation. Table 4.14 shows the input data that are used in Pipesim simulations. The green cells show the input data that are provided to the system and the blue cells are the calculated ones. The VFM supplier's names are marked as A, B, C, D, E. D due to the confidential issues the name of the VFM suppliers are not disclosed, and VFM B is showing Pipesim results.

Table 4.12 Input data for five VFMs

Eval. Points	Allocated Gas (Mmcf/d)	Allocated Oil (Bbl/d)	Allocated Water (Bbl/d)	Allocated Liquid (Bbl/d)	GOR (scf/s tb)	Water Cut (%)	BHP (psi)	BHT (F)	WHP (psi)	WHT (F)	Upstream of choke temp (F)	Choke (/64ths)	Downstream of choke pressure (psi)	Downstream of choke Temp (°F)
A	X	X			X	X	X	X	X	X		X	X	
B	X	X			X	X	X	X	X	X		X	X	
C	X	X			X		X	X	X	X		X	X	
D					X		X	X	X	X		X	X	
E					X		X	X	X	X		X	X	
F					X		X	X	X	X		X	X	
G	X	X			X		X	X	X	X		X	X	
H	X	X			X		X	X	X	X		X	X	
I					X		X	X	X	X		X	X	
J					X		X	X	X	X		X	X	
K					X		X	X	X	X		X	X	
L					X		X	X	X	X		X	X	
M					X	X	X	X	X	X		X	X	
N					X	X	X	X	X	X		X	X	
O					X	X	X	X	X	X		X	X	

Gas, oil flow rate predictions are estimated and plotted for the five VFM suppliers separately. All the predictions are also compared with measured field data. Figures 4.47 & 4.48 show the comparison of the measured field data with the other five VFM suppliers for gas, oil flow rates respectively. As it is clear from the gas and oil flow rate plots, VFM A has the best match in flow

rate predictions with given (measured) rates. While VFM B (PIPESIM Model) has the highest error percentage of measured and estimated flow rates. Flow rate results for VFMs C, D and E show to some extent similar results and an average error about 5%. The VFM B has the highest error, because PIPESIM was not originally designed as a VFM model, we manually tuned some of these options to match pressures, temperatures and given flow rates. In addition, PIPESIM is a steady-state multiphase flow simulator. In other VFMs such as A, C, D, and E, the flow rates are calibrated using an automatic system (e.g., an optimization algorithm). Therefore, further improvements in the prediction results would be expected in all cases in this study if an automatic system uses a similar model. Nevertheless, the prediction trends are expected to be within reasonable agreement with other commercial VFM packages. These similarities in trend among the different VFM models can be seen clearly in Figure 4.49. There are some commercial VFM packages available in the industry and some of them such as LedaFlow and OLGA are also used as the VFM suppliers in our dataset. LedaFlow is an advanced transient multiphase flow simulator and is based on models that are closer to the actual physics of multiphase flow and provides the step change in accuracy and detail needed for longer tiebacks, deeper water and harsher environments (Belt et al. 2011). OLGA is a dynamic multiphase flow simulator.

There is a spike in evaluation points such as K. This high error is due to boundary between the critical and subcritical flow of the choke, so there is a transition from choke critical flow to subcritical flow which the transition section is not measured accurately and it is difficult to capture reliable and accurate measurements in that section.

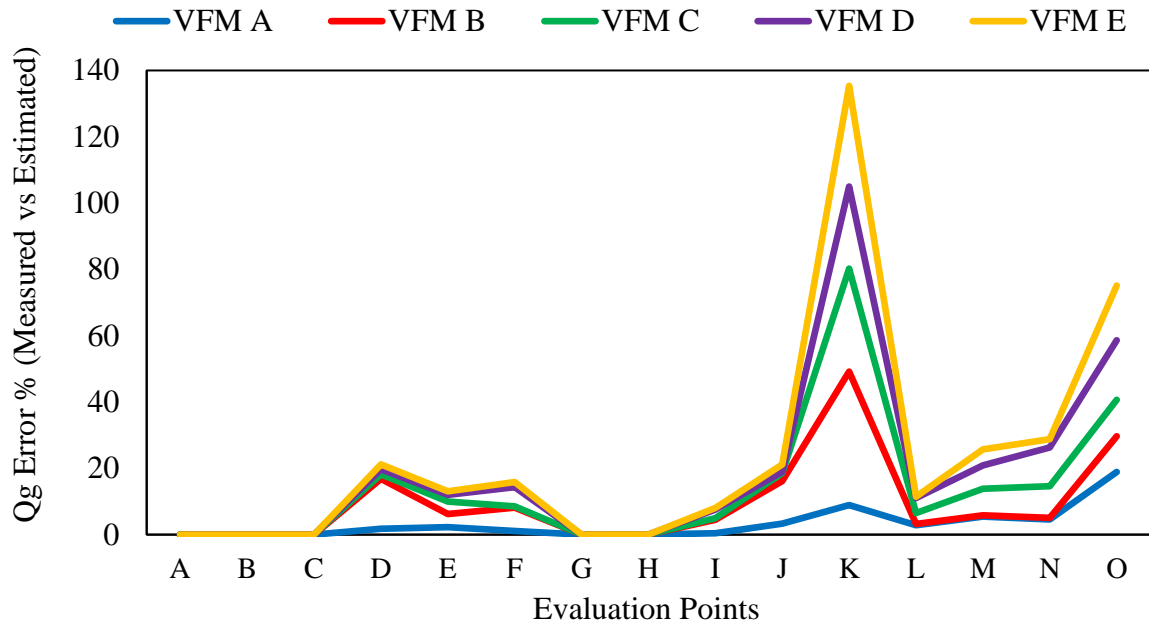

Figure 4.47 Comparison of gas flow rates of five different commercial VFM software

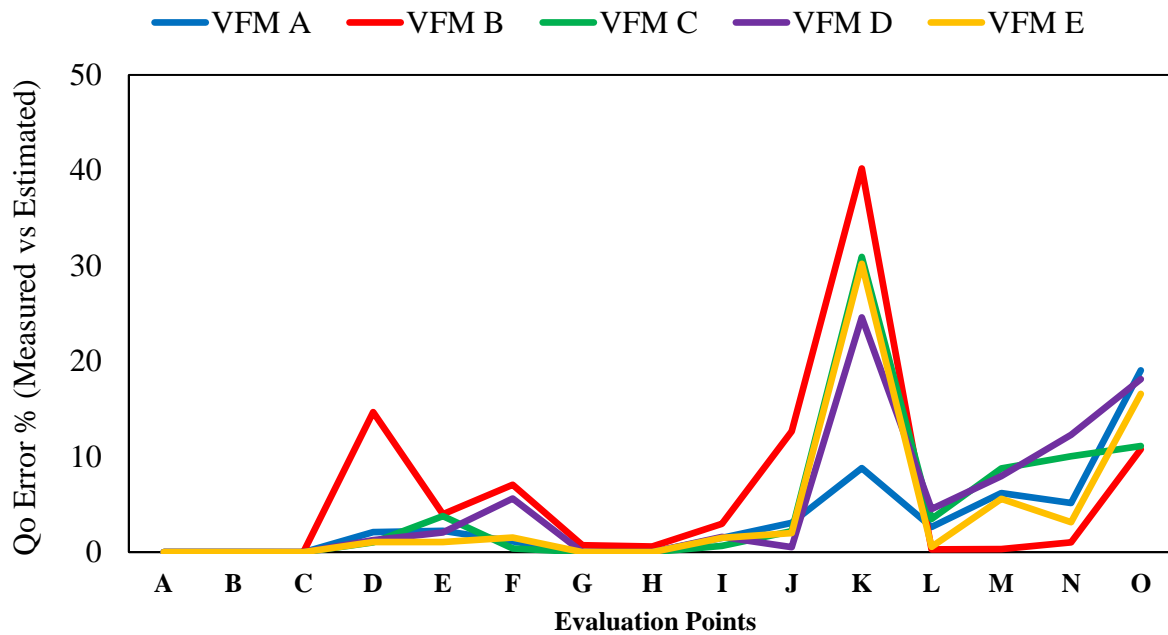

Figure 4.48 Comparison of oil flow rates of five different commercial VFM software

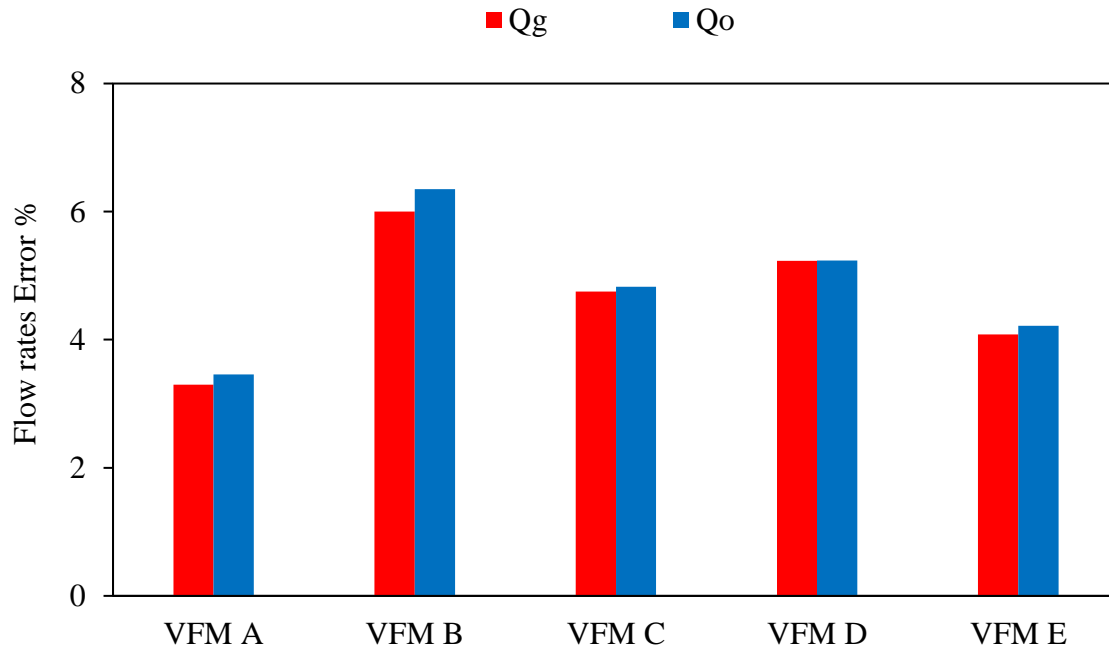

Figure 4.49 Average error percentage of oil and gas flow rates of five different commercial VFM software

CHAPTER 5: THE VFM MODEL APPLIED TO METERING BACKUP

The VFM technology is growing quickly but still it is not generally accepted as a replacement to the multiphase physical metering. Although, the technology has been developed for more than 20 years, the adoption of VFM metering system is still low. However, there other methods of using VFM approach, for instance, as a technique to flag the mal-function of actual multipath flow meters.

The VFM software packages are based on hydraulic models, and some measurements such as downhole pressure and temperatures, in addition to choke valve opening positions, are fed to these software packages as input data to the VFM models. It has been shown by some studies in the literature (Varyan, Haug, and Fonnes 2015) that a VFM model reasonably tuned with adequate pressure and temperature data can detect the failure or mal-function of the any component of the physical meters.

VFM systems are generally steady-state multiphase flow simulators that can predict flow rates by using multivariable optimization solvers. Accuracy and quality of pressure and temperature sensor data as input play a significant role in the successful utilization of VFM systems. Over the life of the field, scale deposition and corrosion may occur on actual flow meters, and consequently, the measurement uncertainty of such sensors can significantly increase.

VFM systems can be used as a backup or to verify loss of calibration of physical meters. The main reasons for physical meter loss of calibration (or failure) are due to the following problems (Falcone et al. 2001).

- Wax, hydrates, scale deposition inside the flow meters
- Slugging damages to the equipment
- Corrosion of physical meter body and sensors

One of the obvious challenges in the physical metering is the difficulty in access to these meters and replacing the failed components, especially in deepwater wells. The reliability and good performance of the multiphase meters are relying on accurate fluid properties data that are obtained from fluid sampling. Therefore, difficulty in obtaining the sampling fluid may also result in inaccuracy of multiphase flow measurements. High GVF and WCs also have significant impact on the metering system. In general, when there is a drastic change in GVF and WC levels, the uncertainty of the multiphase meters also increase. Therefore, an additional backup system to the physical meters is needed to aid the monitoring of actual physical meters going “off calibration”. The combination of hard and soft measurement tool would provide an enhanced method for predicting the flow rate of the wells in the field. The objective of this chapter is to evaluate if the VFM technology could detect any erroneous measurements in physical multiphase flow meter. In case of malfunction of any component of physical meters, VFM model can be used as a backup and alternative to physical meters.

The VFM model and production data used in this chapter is the same as presented in chapter 4. The simulations are divided to six different cases. In the first three cases (1,2,3) no flow rate data are provided for tuning the model while in second three cases (4,5,6) some flow rate data are provided from early time and mid time production into the flow model. In cases 1,2,3 choke correlations are used to perform the sensitivity analysis. Basically, the choke correlations and the fluid properties are used to tune the model for the first three cases. In cases 4,5,6 in addition to the choke correlations and the fluid properties, some flow rate data also are used to tune the flow model.

5.1 Results and Discussions

Figure 5.1 presents the error percentages for predicted water flow rates for evaluation points from A through O. As can be seen from figures 5.1, there is a clear trend of large errors for water flow rate prediction between points D and L. In practice, these large errors on flow rate prediction would indicate malfunction of the flow meter. In fact, the operator which provided the field data for this study confirmed that after point M, the water flow meter was fixed and re-calibrated, and the previous measurements (between points D and L) probably have erroneous measurements due to flow meter malfunction. This information would confirm the potential application of the use of VFM models for metering backup and monitoring system to indicate flow meter malfunction.

Another indication of the water flowmeter malfunction is the increasing average error for the water cut as more and more information (or measured data points) is given to the VFM model between cases 1 to 6, as shown in figure 5.2. This trend of increasing error is the opposite for the prediction of oil and gas (see Figure 5.2), as more measured flow rates points is provided to the VFM system, the average error decreases. The operator who provided the data also confirmed not observing any problems about calibration in the flow meters for oil and gas.

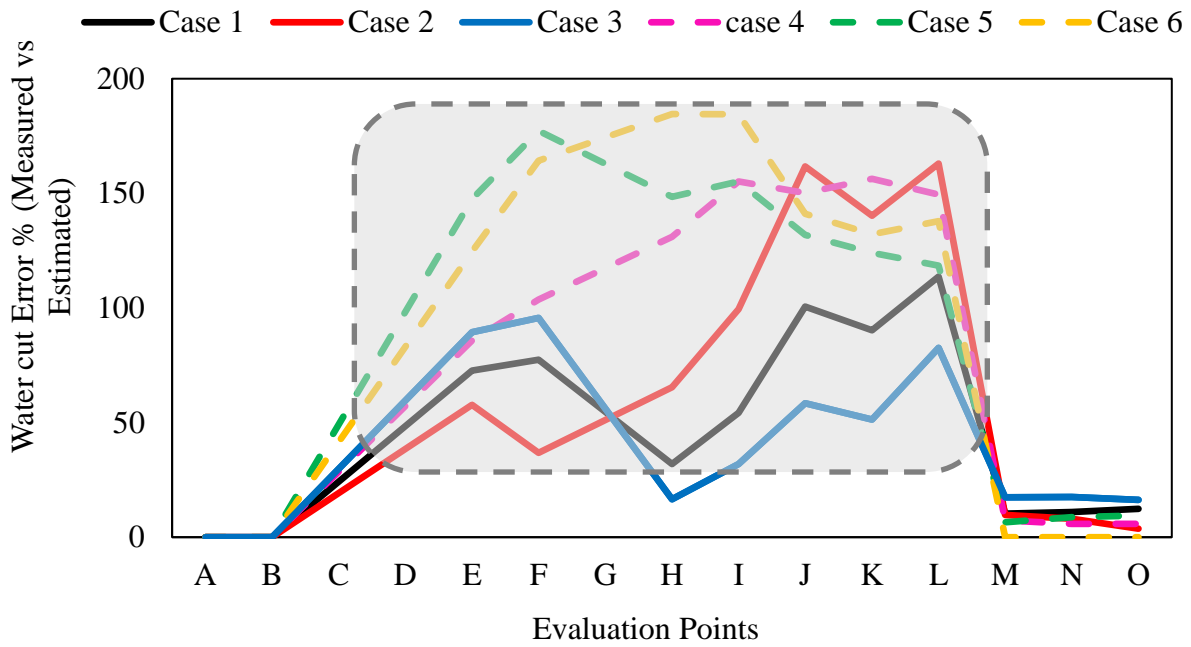

Figure 5.1 Error percentage for predicted water flow rates for evaluation points A through O for all cases

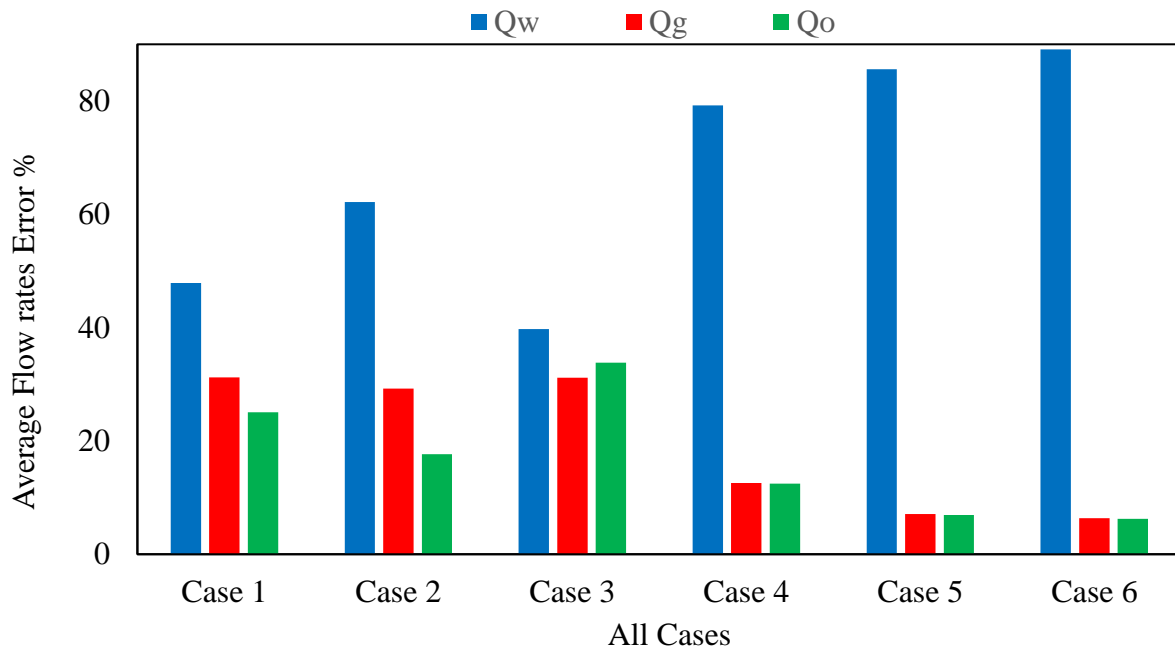

Figure 5.2 Average flow rates error percentage for all six cases

CHAPTER 6: VFM MODEL APPLIED TO PRODUCTION ALLOCATION

In the oil and gas industry, production allocation is defined as the estimated production rate from each well from a particular field which has multiple wells. Accurate allocation is necessary because of several reasons (Cramer et al. 2011):

- Field surveillance
- Accounting for production rates of individual wells to its owners
- Reservoir management

In conventional offshore allocations, well tests using test separators (see Section 2.1 for more details) are commonly deployed to allocate the production from multiple wells. Well test duration can vary from a few hours (1-4 hours) or can take as long as 24 hours. The duration of the well test is often dependent of how long it takes for a particular well reach stable flowing conditions (ideally, steady-state flow is desired). After stable flow is achieved, production data (flow rates, pressures, temperatures, choke opening, among other parameters) are recorded for a few hours during the stable flow period. The measured flow rates are averaged in time for the stable flowing conditions for each well. These rate are then used for the entire following month, until a new well test is performed. Conventionally, these well flow rates are not updated until the upcoming well test.

Continuous well performance monitoring for individual well can play a key role while determining the reservoir behavior and also to optimize the production (Poullisse et al. 2006). Nevertheless, testing individual wells continuously is often not economically feasible. To obtain continuous flow rate measurement for individual well would require installation of test separators or multiphase meters on each well, which can become expensive.

The main objective in this chapter is to evaluate the performance of the VFM model described in Chapter 3, applied to production allocation process. This evaluation includes a comparison between daily allocation based on the traditional allocation method of using a test separator and the allocation results from the VFM model described in this study (see Chapter 3). The production data used in the evaluation includes two deepwater wells, as shown in Figure 6.1. These two wells are connected, via flowlines, to a platform, where the produced fluids are comingled into a single production separator. Allocation simulations are carried out for a period of time of two years.

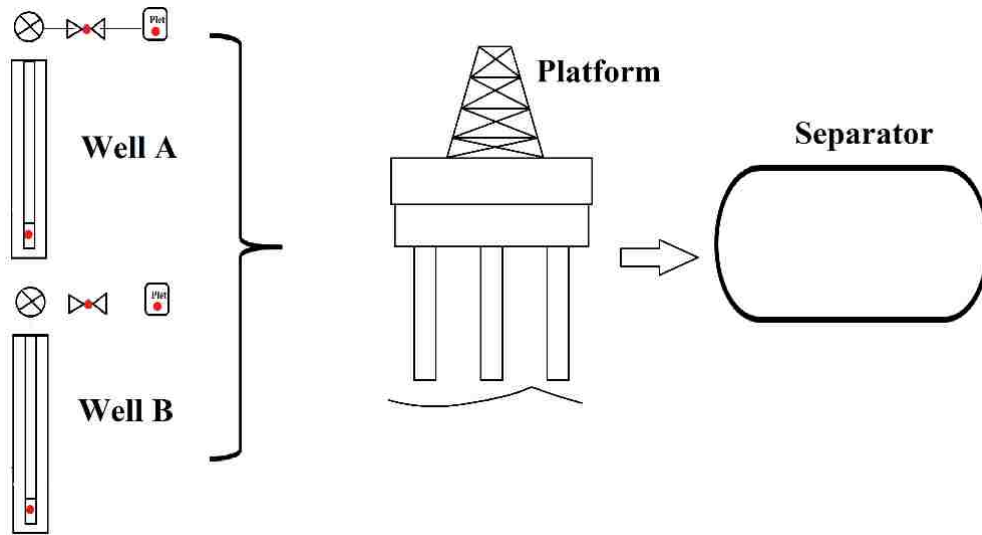

Figure 6.1 Schematic of two wells commingled to the same platform

6.2 Description of the calibration of the VFM model using well test data

Daily production and monthly well test data are used to carry out the evaluation of the VFM model proposed in this study for allocation process. Monthly well test data are compared to flow rate predictions from the VFM model. The well test data is assumed to be the reference (correct) data, as it measures the flow rates of oil, gas and water for each well separately. The monthly well test data is also used tune (or calibrate) the VFM flow model. This calibration process

involves the selection of the most appropriate choke valve and wellbore flow correlations, and also to calibrated deviations in fluid properties. These parameters are tuned to minimize the errors between the estimated and the measured flow rates of oil, gas and water, and wellhead pressures. A workflow diagram of the calibration process using well test data is shown in Figure 6.2.

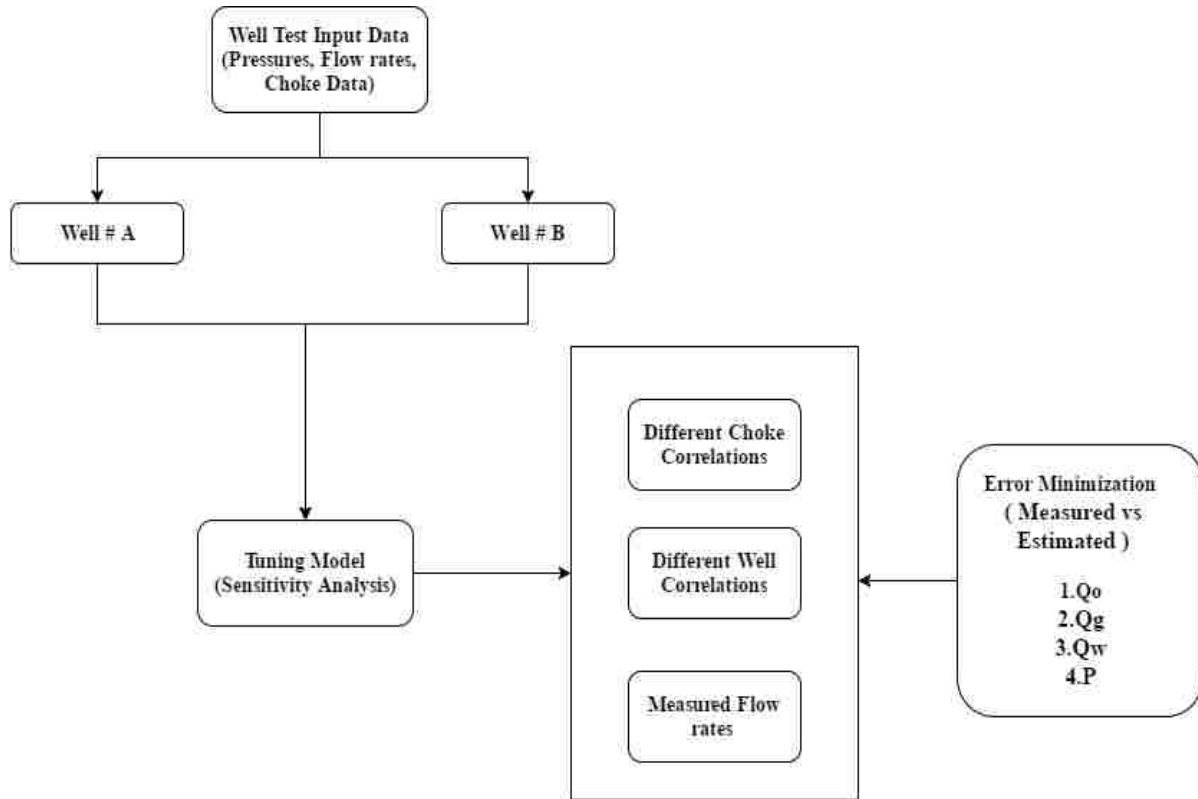

Figure 6.2 Workflow diagram showing the basic steps on the calibration process of the VFM model using well test data

6.3 Results and Discussion

For both wells A and B, daily data for pressures, temperature, and choke opening was available. Daily flow rate for each well was only available through the allocation process obtained via test separators, which used monthly well test data. Because the conditions in both wells changed constantly for different during the two year of production data used, only 27 points were selected for the year one, and 23 evaluation points for the year two. As the VFM model deployed

in this study is a steady-state flow model, these points were selected when the conditions for each well were stable for a minimum period of two days. For each evaluation, time-average of the pressures, temperature, choke opening and allocated flow rates were calculated. The estimated allocated rate from the VFM model are then compared with the allocated rates based on the well test. The objective of the comparison is to evaluate the performance of well tests in estimating the flow rate of the individual well (allocated rate).

The procedure of the simulations is as follow:

- The well test periods are specified, some test are carried out for twenty days, some for a month and some for about two months.
- The production data for the specified well test period are selected.
- Two points (daily production data) from the data are selected in steady state condition. The average of the two points are used as an input data to the system.
- The flow rates of each well are predicted by the flow model with using and adjusting the measured total flow rate of two wells.
- The allocated rate based on the flow model are compared and analyzed with the allocated rates base on the well testing.

6.3.1 Year one (Y1)

Figures 6.3 and 6.4 show the comparison between the estimated flow rates based on well tests and estimated results using the VFM model for both wells A and B for the year one. Figures 6.5 and 6.6 show the relative error percentage between estimated by well tests and estimated by flow model respectively. As it can be seen from Figure 6.5, for evaluation points 1 to 7 for well A, there is an error of about -3% between the estimated rates by the well test and the flow model. This result shows that the allocated rates using the conventional allocation method (using monthly well

test data) is likely given appropriate results. From points 8 to 16, well A is shut-in. During this period of time, only well B is producing, as it is shown in figure 6.5. Since there are only produced fluids from well B being measured at the production separator in the platform, the measured rates for this well during this period is expected to have low uncertainty. For this period of time (for points 8 to 16 in Figure 6.6), the VFM flow rate prediction for oil, gas, and water flow rates show a difference of less than 5% in average between the estimated rates by the well test and the flow model. This small difference of 5% shows that the VFM model is tuned and performing reasonably. Another well test is done at point 15 (Figure 6.3). But the error percentage after point 18 increased, because as far as it gets from the well test date the errors get larger. When the well A started flowing again in point 17, the error rises to about 10% for well A, and to -5% for well B.

From points 18 to 24, there error is calculated about $\pm 2\%$ and $\pm 5\%$ which is an acceptable range. Point 22 shows a relative error of 10% for the gas rate due to sudden increase in GOR. As the well test performed in near point 8 did not include such a high GOR, it can be expected that the VFM prediction could provide better results than the allocated estimation, since the VFM model should include the hydrodynamic modeling of the flowing to account for variations in GOR. Points 25 -27 show an increasing relative error around -25%. The larger errors for these points is probably due to decrease in choke openings, from 16/64th to 8/64th. When choke openings are decreasing, the flow meter could not allocate the correct rate to the correct well in the well test process.

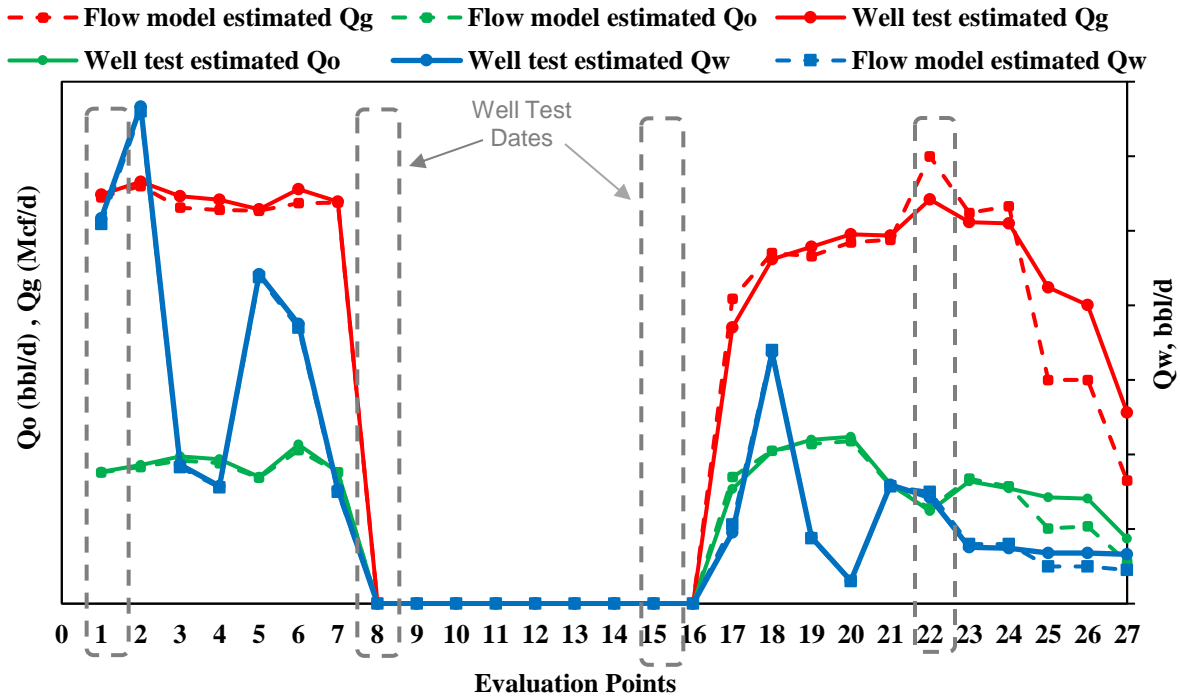

Figure 6.3 Well # A estimated flow rates by the well test & the flow model for the year one

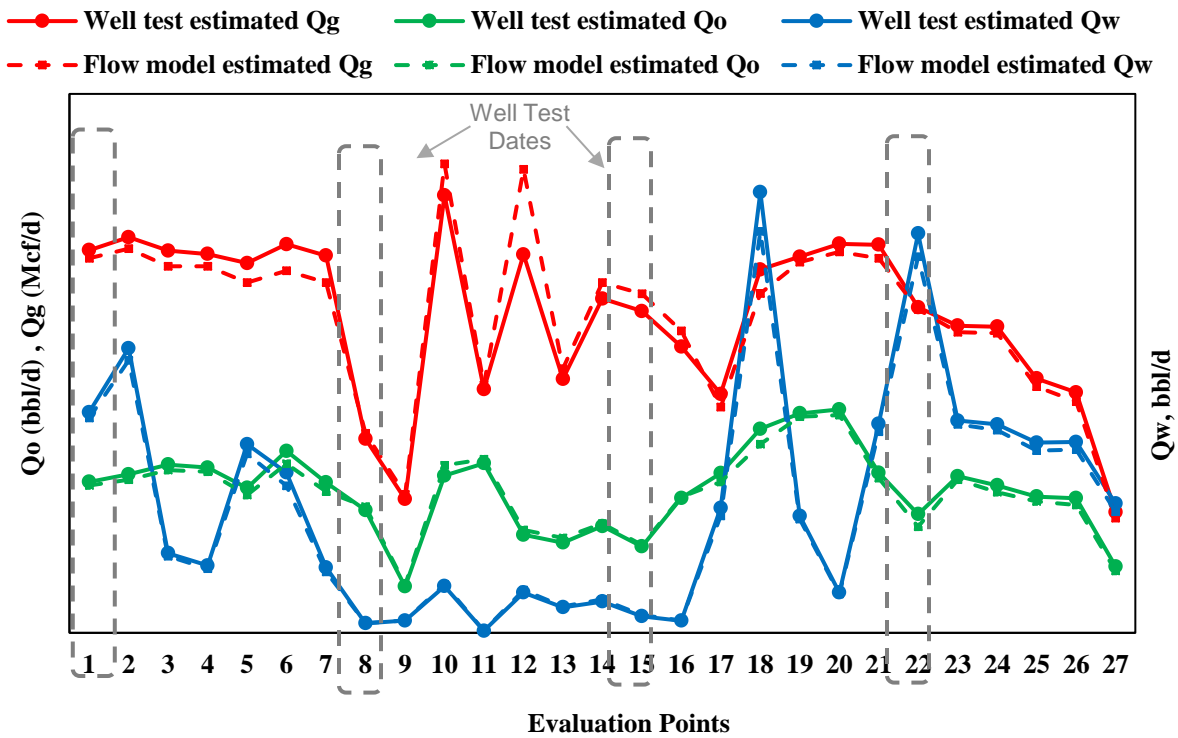

Figure 6.4 Well # B estimated flow rates by the well test & the flow model for the year one

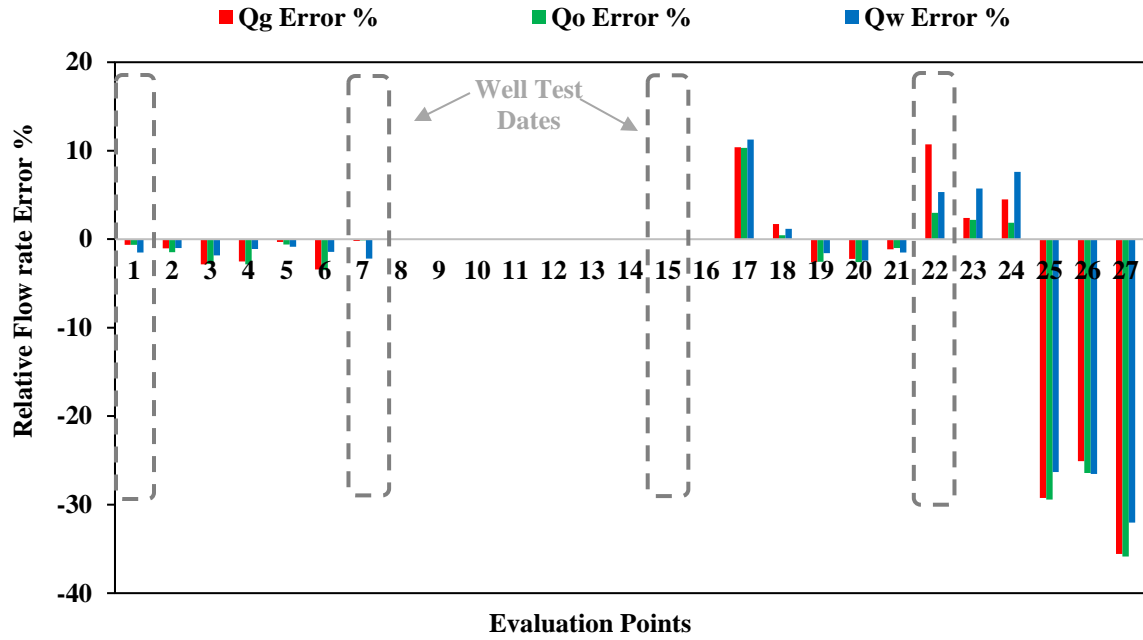

Figure 6.5 Well # A flow rate relative error % for the year one

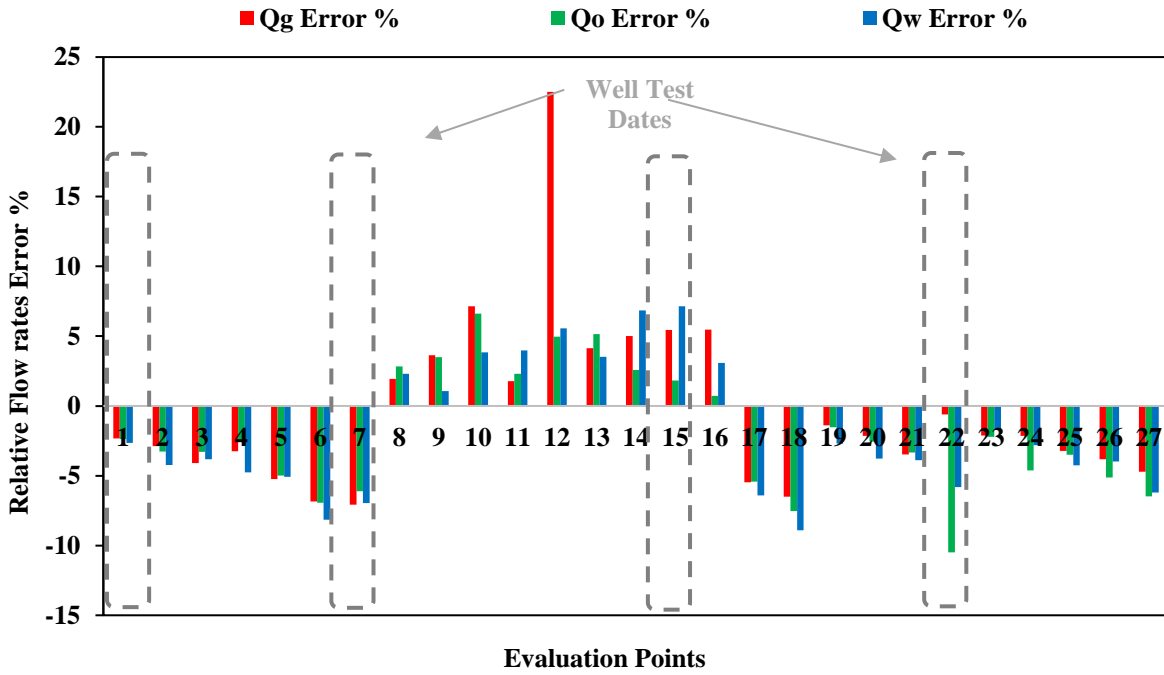

Figure 6.6 Well # B flow rate relative error % for the year one

6.3.2 Year two (Y2)

Figures 6.7 and 6.8 show the comparison between the estimated data from well tests and estimated results from the flow model using the VFM approach for both wells A and B for the year two. Figures 6.9 and 6.10 show the relative error % between the estimated rates by the well test and the flow model, respectively. As it can be seen from Figure 6.9 and 6.10, for evaluation points 9 to 14, well B is shut and the errors for rate estimation via VFM model is low for well A, with errors levels no larger than 5%. This indicates that VFM model is performing appropriately. Therefore, while a single well is flowing, the VFM can predict the flow rate with a reasonable accuracy, which give confidence on the quality of this VFM prediction tool. However, it possible to notice for points 15 to 23, that as far as it get from the well test date the larger the errors. This result would indicate that the conventional allocation method is not providing accurate results, and the VFM rate predictions should be more reliable than the conventional method, as it is validate when only one well is flowing and it show reasonable predictions.

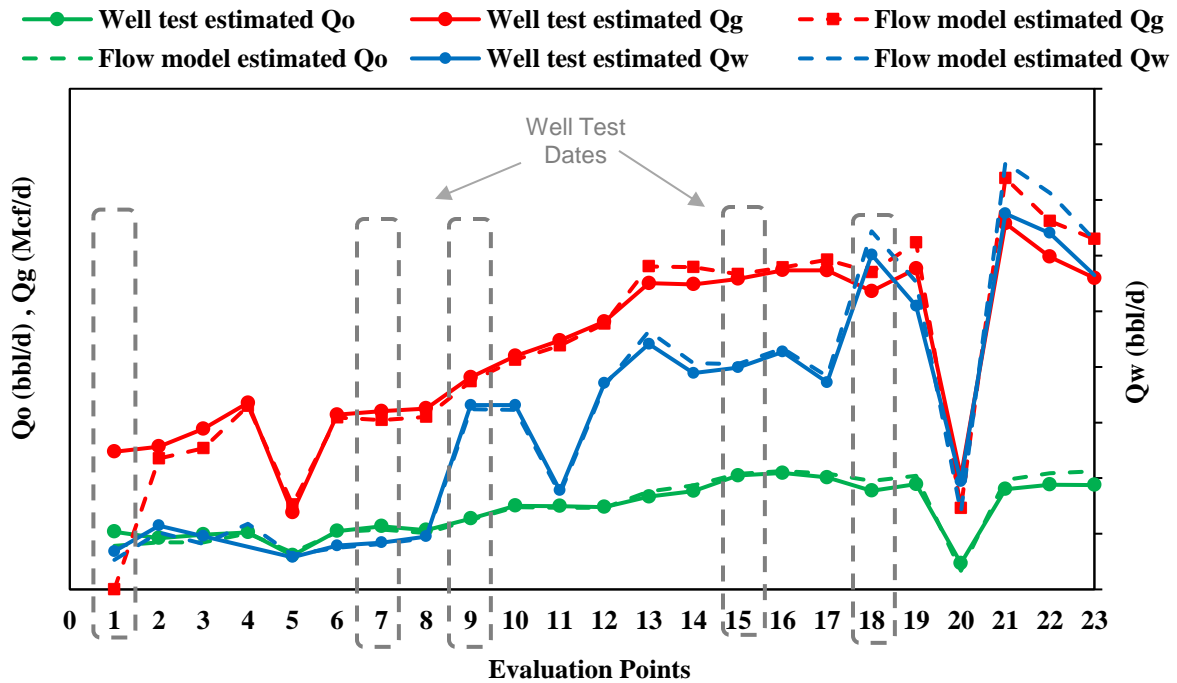

Figure 6.7 Well # A estimated flow rates by the well test & the flow model for the year two

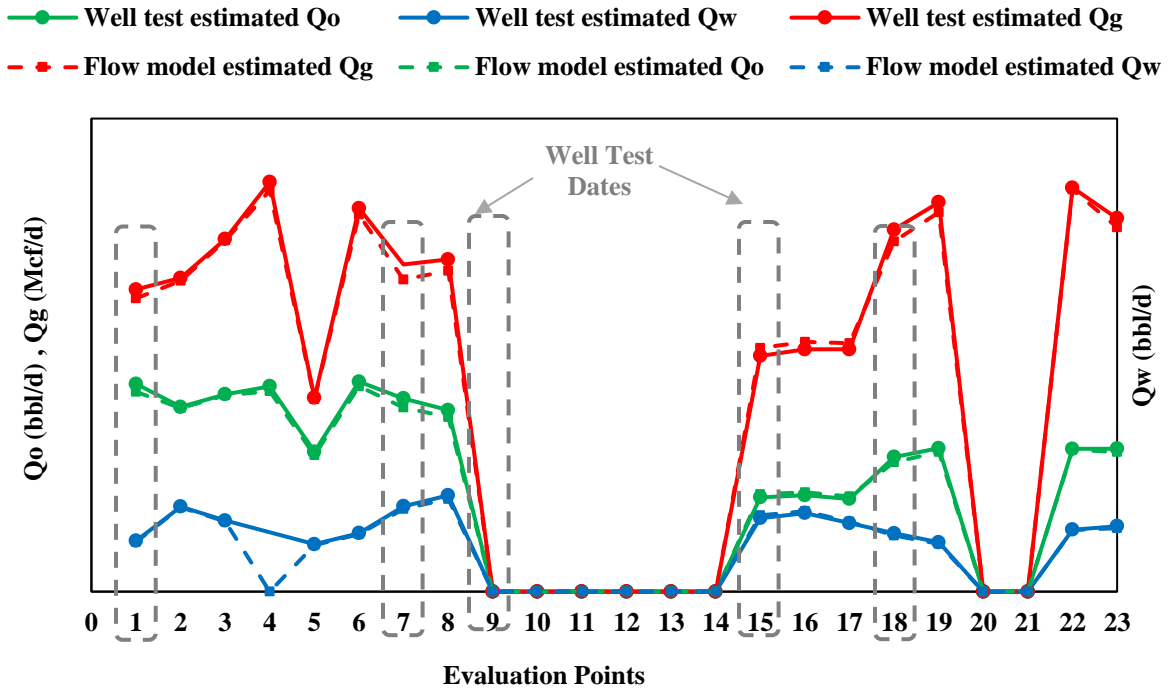

Figure 6.8 Well # B estimated flow rates by the well test & the flow model for the year two

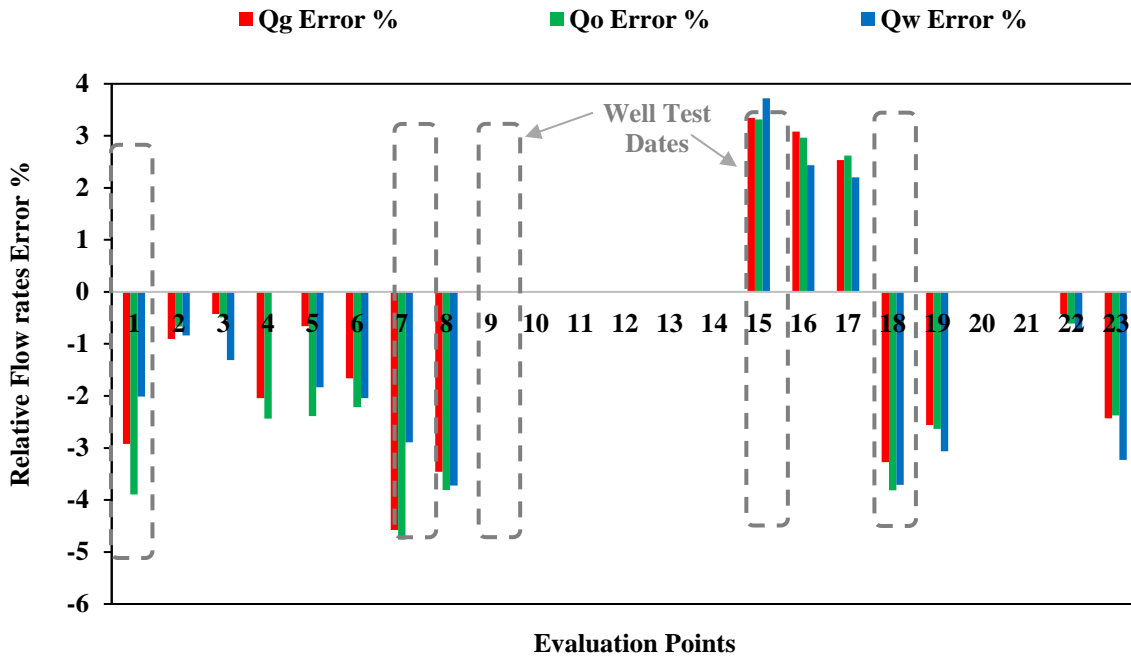

Figure 6.9 Well # B flow rate relative error % for the year two

CHAPTER 7: CONCLUSIONS

The main objectives of this research is to evaluate and analyze the flow rate prediction of well production calculated by VFM models. Flow rate predictions are calculated by providing comprehensive input data in six different cases, while performing these simulations using different VFM models. The first three cases include pre-tuning cases and no flow rate data are provided as input data. Only pressure and temperature measurements (downhole) are provided in addition to water cut and GOR from early production data. For the pre-tuning cases, errors on flow rate determination are significantly high (with over predictions up to 20%).

The second part of the analysis include tuning cases and flow rates from early and mid-time production data. The accuracy for all VFM models increased significantly for the tuned cases (10% in average), reaching levels which are comparable to the accuracy of conventional well testing methods.

The results from this study also shows that VFM models can be used as backup alternative for physical multiphase or single-phase flow meters. The malfunction of a water flow meter could be identified by the use of a VFM model, which malfunction was confirmed by the operator who provided the field dataset for this study. The VFM model results for both with and without tuning cases show that, these models can indicate erroneous measurements of erroneous reading from malfunction meters.

One of the another objectives of the study is to evaluate the performance of VFMs in production allocation process. It can be concluded that VFMs are reasonable tools to determine the inaccuracy of well test flow rate estimations. The allocated flow rates by test separator monthly could not detect the changes in the flowrates that may be influenced by decreasing or increasing the GOR or other factors such as choke opening and water cut changes.

REFERENCES

- API Recommended Practice for Measurement of Multiphase Flow. 2005: API Publishing Services, 1220 L.
- Abdel Rasoul, R. R., Salah, A., Daoud, A. 2011. Production Allocation in Multi-Layers Gas Producing Wells Using Temperature Measurements (By Genetic Algorithm). SPE-139260-MS, presented in SPE Middle East Oil and Gas Show and Conference, Manama, Bahrain, 25-28 September.
- Abdul-Majeed, G. H., Maha, R. A.-A. 1991. Correlations Developed To Predict Two-Phase Flow Through Wellhead Chokes. 10.2118/91-06-05, presented in 88-39-26 PETSOC Conference Paper, Calgary, Alberta, June 12 - 16.
- Al-Kadem, M. S., Al Khelaiwi, F. T., Al Mashhad, A. S., Al Dabbous, M. S., Al Amri, M. A. 2014. A Decade of Experience with Multiphase Flow Meters. IPTC-18162-MS, presented in International Petroleum Technology Conference, Kuala Lumpur, Malaysia, 10-12 December
- Al-Yarubi, Q. 2010. Phase flow rate measurements of annular flows. PhD thesis, University of Huddersfield.
- Amin, A. 2015. Evaluation of Commercially Available Virtual Flow Meters (VFMs). OTC-25764-MS, presented in Offshore Technology Conference, Houston, Texas, USA, 4-7 May.
- Beggs, H. D. 1991. Production Optimization: Using NODAL Analysis, OGC Publications
- Belt, R., Duret, E., Larrey, D., Djoric, B., Kalali, S. 2011. Comparison of Commercial Multiphase Flow Simulators with Experimental and Field Databases. BHR-2011-I2, presented in 15th International Conference on Multiphase Production Technology, Cannes, France.
- Blaney, S. 2008. Gamma radiation methods for clamp-on multiphase flow metering. PhD thesis, Cranfield University.
- Brill, J. P., Mukherjee, H. K. 1999. Multiphase Flow in Wells, Henry L. Doherty Memorial Fund of AIME, Society of Petroleum Engineers Incorporated
- Ceccio, S., George, D. 1996. A review of electrical impedance techniques for the measurement of multiphase flows. Transactions-American Society of Mechanical Engineers Journal of Fluids Engineering 118: 391-399.
- Corneliussen, S. 2005. Handbook of Multiphase Flow Metering, Norwegian Society for Oil and Gas Measurement (NFOGM)
- Cramer, R., Griffiths, W. N., Kinghorn, P., Schotanus, D., Brutz, J. M., Mueller, K. 2012. Virtual Measurement Value during Start Up of Major Offshore Projects. IPTC-14518-MS, presented in International Petroleum Technology Conference, Bangkok, Thailand, 7-9 February.

- Cramer, R., Schotanus, D., Ibrahim, K., Colbeck, N. 2011. Improving Allocation and Hydrocarbon Accounting Accuracy Using New Techniques. SPE Economics & Management
- Dellarole, E., Bonuccelli, M., Antico, L., Faluomi, V. 2005. Virtual Metering And Flow Allocation: Models, Tools And Field Results. OMC-2005-091, presented in Offshore Mediterranean Conference, Ravenna, Italy,16-18 March.
- Economides, M. J., Hill, A. D., Ehlig-Economides, C., Zhu, D. 2012. Petroleum Production Systems, PTR Prentice Hall
- Falcone, G., Hewitt, G. F., Alimonti, C., Harrison, B. 2001. Multiphase Flow Metering: Current Trends and Future Developments. SPE-71474-MS, presented in SPE Annual Technical Conference and Exhibition, New Orleans, Louisiana,3 October.
- Gioia Falcone, G. H., C. Alimonti. 2009. Multiphase Flow Metering: Principles and Applications, Elsevier
- Hagedorn, A. R., Brown, K. E. 1965. Experimental Study of Pressure Gradients Occurring During Continuous Two-Phase Flow in Small-Diameter Vertical Conduits. 940-PA SPE Journal Paper
- Haldipur, P., Metcalf, G. D. 2008. Virtual Metering Technology Field Experience Examples. OTC-19525-MS, presented in Offshore Technology Conference, Houston, Texas, USA,5-8 May.
- Haouche, M., Tessier, A., Deffous, Y., Authier, J.-F. 2012. Virtual Flow Meter pilot: based on Data Validation and Reconciliation Approach. SPE-157283-MS, presented in Society of Petroleum Engineers, SPE International Production and Operations Conference & Exhibition,Doha, Qatar, 14-16 May.
- Hasan, A. 2010. Multiphase Flow Rate Measurement Using a Novel Conductance Venturi Meter: Experimental and Theoretical Study In Different Flow Regimes. PhD thesis, University of Huddersfield.
- Heddle, R., Foot, J., Rees, H. 2012. ISIS Rate & Phase: Delivering Virtual Flow Metering for 300 Wells in 20 Fields. SPE-150153-MS, presented in SPE Intelligent Energy International, Utrecht,The Netherlands,27-29 March.
- Ibrahim, M. H. 2008. Optimum Allocation Methodology for Gas Condensate Wells. SPE-111442-MS, presented in SPE North Africa Technical Conference & Exhibition, Marrakech, Morocco,12-14 March.
- Jenson, F. 1992. A Substitute for Test Separators. SPE-24289-MS, presented in European Petroleum Computer Conference, Stavanger, Norway,24-27 May.
- Kuchpil, C., Caetano, E. F., Costa e Silva, C. B., Pinheiro, J. A., Labanca, E. L. 2003. Multiphase Flow Metering - Operational Experience on Sub-sea Production Manifolds. OTC-15174-MS, presented in Offshore Technology Conference, Houston, Texas,5-8 May.

- Lannom, D. A., Hatzignatiou, D. 1996. Multiphase-flow choke correlation limits analyzed. *Oil and Gas Journal*, Volume 94 (15).
- Leskens, M., Smeulers, J. P. M., Gryzlov, A. 2008. Downhole Multiphase Metering In Wells By Means Of Soft-sensing. SPE-112046-MS, presented in Intelligent Energy Conference and Exhibition, Amsterdam, The Netherlands, 25-27 February.
- Li, Z. Y., Kitami, H., Kawaoto, H., Watanabe, T. 2004. A Turbine Flow Meter for Multiphase Flow. SPE-88741-MS, presented in Abu Dhabi International Conference and Exhibition, Abu Dhabi, United Arab Emirates, 10-13 October.
- Loseto, M., Bagci, A. S., Gilbert, R., Chacon-Fonseca, J. R. 2010. Virtual Flowrate Metering in Subsea Producers & Injectors Enables Integrated Field & Reservoir Management: Don Development Case Study. SPE-128678-MS, presented in SPE Intelligent Energy Conference and Exhibition, Utrecht, The Netherlands, 23-25 March.
- McCain, W. D. 1990. *The Properties of Petroleum Fluids*, PennWell Books
- McCracken, M., Chorneyko, D. M. 2006. Rate Allocation Using Permanent Downhole Pressures. SPE-103222-MS, presented in SPE Annual Technical Conference and Exhibition, San Antonio, Texas, USA, 24-27 September.
- Melbø, H., Morud, S. A., van der Geest, R., Bringeda, B., Stenersen, K. 2003. Software That Enables Flow Metering of Well Rates With Long Tiebacks and With Limited or Inaccurate Instrumentation. OTC-15363-MS, presented in Offshore Technology Conference, Houston, Texas, 5-8 May.
- Mokhtari, K., Waltrich, P. 2016. Performance evaluation of multiphase flow models applied to virtual flow metering. *WIT Transactions on Engineering Sciences* 105: 99-111.
- Munir, M. W., Khalil, B. A. 2013. Cross Correlation Velocity Measurement of Multiphase Flow. *International Journal of Science and Research (IJSR)*, Volume 4 (2).
- Muradov, K. M., Davies, D. R. 2009. Zonal Rate Allocation in Intelligent Wells. SPE-121055-MS, presented in EUROPEC/EAGE Conference and Exhibition, Amsterdam, The Netherlands, 8-11 June.
- Patel, P., Odden, H., Djoric, B., Garner, R. D., Veal, H. K. 2014. Model Based Multiphase Metering and Production Allocation. OTC-25457-MS, presented in Offshore Technology Conference-Asia, Kuala Lumpur, Malaysia, 25-28 March.
- PIPESIM Multiphase Flow Simulator Manual, 2013, Schlumberger.
- Poullisse, H., van Overschee, P., Briers, J., Moncur, C., Goh, K. C. 2006. Continuous Well Production Flow Monitoring and Surveillance. SPE-99963-MS, presented in Intelligent Energy Conference and Exhibition, Amsterdam, The Netherlands, 11-13 April.

- Sæten, S. 2015. Production Allocation of Oil and Gas: A case Study of the Skarv Field. MS Thesis, Norwegian University of Science and Technology.
- Thorn, R., Johansen, G., Hjertaker, B. 2012. Three-phase flow measurement in the petroleum industry. *Measurement Science and Technology* 24 (1): 012003.
- Toskey, E. D. 2012. Improvements to Deepwater Subsea Measurements RPSEA Program: Evaluation of Flow Modelling. OTC-23314-MS, presented in Offshore Technology Conference, Houston, Texas, USA, 30 April-3 May.
- Udofia, E. E., Akporuno, M., Van Den Berg, F. G., Beijer, V., Oguntimehin, A., Oni, O. 2012. u. SPE-150450-MS, presented in SPE Intelligent Energy International, Utrecht, The Netherlands, 27-29 March.
- Varyan, R., Haug, R. K., Fonnes, D. G. 2015. Investigation on the Suitability of Virtual Flow Metering System as an Alternative to the Conventional Physical Flow Meter. SPE-176432-MS, presented in SPE/IATMI Asia Pacific Oil & Gas Conference and Exhibition, Nusa Dua, Bali, Indonesia, 20-22 October.
- Wildhaber, E. 1966. Positive-displacement unit, US 3236186 A.
- Wu, X., Humphrey, K., Liao, T. T. 2012. Enhancing Production Allocation in Intelligent Wells via Application of Models and Real-Time Surveillance Data. SPE-155031-MS, presented in SPE International Production and Operations Conference & Exhibition, Doha, Qatar, 14-16 May.

APPENDIX A: FLUID PROPERTY CORRELATIONS FOR BLACK OIL MODEL

There are many correlations that are used to determine R_s (scf/STB), which are categorized from extremely heavy oil to very light oil. Standing correlation is used for solution gas oil ratio as the oil reservoir has light oil in our case (McCain 1990):

$$R_s(P, T) = C \cdot \gamma_G \cdot \left[\frac{P}{A(T) \cdot 18} \right]^{1/0.83}$$

A is a function of the fluid temperature and the oil API density:

$$\log_{10}^A = 0.00091 \cdot T - 0.0125 \text{ API}$$

C is a calibration constant. The default value for the calibration constant is 1.

A.2. Oil formation volume factor for saturated system

For saturated oil reservoirs ($P < P_b$) the oil formation volume factor B_{ob} depends on R_s and temperature. Standing correlation is used:

$$B_{ob} = 0.972 + 0.000147 F^{1.175}$$

F is a correlating factor, which is calculated by using R_s and specific gravities:

$$F = R_s \left(\frac{\gamma_g}{\gamma_o} \right)^{0.5} + 1.25 T$$

A.3. Oil formation volume factor for unsaturated system

Oil formation volume factor, B_o , for pressures above the bubble point is given by:

$$B_o = B_{ob}(R_{sb}) \cdot \exp[\lambda Z_o (P_b - P)]$$

Where Z_o is the oil compressibility and λ is a calibration factor.

A.4. Oil Viscosity

Dead Oil Viscosity at stock tank pressure and the correlation is:

$$\mu_{od} = 10^x - 1$$

Where

$$x = yT^{-1.163}$$

$$y = 10^Z \quad Z = 3.0324 - 0.02023 \cdot API$$

A.5. Live Oil Viscosity

$$\mu_{ob} = A \cdot \mu_{od}^B$$

A, B are function of the solution gas-oil ratio R_s

$$A = 0.2 + \left(\frac{0.8}{10^{0.000852 R_s}} \right) \quad B = 0.482 + \left(\frac{0.518}{10^{0.000777 R_s}} \right)$$

A.6. Undersaturated Oil Viscosity,

$$\mu_{ou} = \mu_{ob} \left(\frac{P}{P_b} \right)^A$$

where,

$$A = 2.6 P^{1.187} \exp(-8.98 \times 10^{-5} P - 11.513)$$

A.7. Gas Compressibility

Standing Z-factor correlation is used to calculate the gas compressibility:

$$Z = \frac{A + (1 - A)}{e^{xB} + FP_r^G}$$

Where the coefficient A to G are:

$$A = 1.39 (T_r - 0.92)^{0.5} - 0.36 T_r - 0.101$$

$$B = (0.62 - 0.23T_r)P_R + \left[\frac{0.666}{T_r - 0.86} - 0.037 \right] P_R^2 + \frac{0.32 P_R^6}{10^{9(T_R-1)}}$$

$$C = (0.132 - 0.32 \log(T_R))$$

$$D = 10^{(0.3016 - 0.49T_R + 0.1824 T_R^2)}$$

$$T_c = 187 + 330 \gamma_G - 71.5 \gamma_G^2$$

$$T_r = \frac{T}{T_c}$$

$$P_c = 706 - 51.7 \gamma_G - 11.1 \gamma_G^2$$

$$P_r = \frac{P}{P_c}$$

T_R = reciprocal of the reduced temperature.

A.8. Gas Viscosity

$$\mu_g = K \cdot \exp[X \cdot \rho_g^Y]$$

Where

$$K = \frac{(7.77 + 0.183 \cdot \gamma_G) \cdot (T + 460)^{1.5}}{(122.4 + 373.6 \cdot \gamma_G + T + 460)} \cdot 10^{-4}$$

$$X = 2.57 + \frac{1914.5}{T} + 0.275 \gamma_g$$

$$Y = 1.11 + 0.04 X$$

APPENDIX B: RELATED SOFTWARE

PIPESIM: PIPESIM software is a steady state, multiphase flow simulator. PIPESIM models multiphase flow from the reservoir to the wellhead. Flow line and surface facility performance can be calculated to generate comprehensive production system analysis. PIPESIM software can be integrated with the Avocet production operations software platform, and the Petrel E&P software platform to deliver a singular solution, spanning reservoir simulation to production.

PIPESIM could model the entire production system from the reservoir to the processing facility. The applications in PIPESIM include:

- Well Performance Analysis
- Pipelines and facilities
- Network Analysis Module

The PIPESIM steady-state multiphase flow simulator enables production optimization over the complete lifecycle from complex individual wells to vast production networks (PIPESIM 2013).

VITA

Kahila Mokhtari Jadid was born in 1982, in Urumia, Iran. She attended Azarm high school and received her diploma in 2000. She went to Urumia University and graduated with a degree in Bachelor of applied physics in 2005. She received a MSc degree in Petroleum Engineering from the Middle-East Technical University of Istanbul in 2011, with focus on carbon capture and storage.