Doctoral Dissertations

Student Theses and Dissertations

Spring 2015

System integration of hydrogen energy technologies using renewable energy resources

Tarek A Mohammed Hamad

Follow this and additional works at: https://scholarsmine.mst.edu/doctoral_dissertations



Part of the [Mechanical Engineering Commons](#)

Department: **Mechanical and Aerospace Engineering**

Recommended Citation

Hamad, Tarek A Mohammed, "System integration of hydrogen energy technologies using renewable energy resources" (2015). *Doctoral Dissertations*. 2384.

https://scholarsmine.mst.edu/doctoral_dissertations/2384

This thesis is brought to you by Scholars' Mine, a service of the Missouri S&T Library and Learning Resources. This work is protected by U. S. Copyright Law. Unauthorized use including reproduction for redistribution requires the permission of the copyright holder. For more information, please contact scholarsmine@mst.edu.

SYSTEM INTEGRATION OF HYDROGEN ENERGY TECHNOLOGIES
USING RENEWABLE ENERGY RESOURCES

by

TAREK A MOHAMMED HAMAD

A DISSERTATION

Presented to the Faculty of the Graduate School of the

MISSOURI UNIVERSITY OF SCIENCE AND TECHNOLOGY

In Partial Fulfillment of the Requirements for the Degree

DOCTOR OF PHILOSOPHY

In

MECHANICAL ENGINEERING

2015

Approved

Dr. Ashok Midha, Advisor

Dr. John Sheffield

Dr. Robert G. Landers

Dr. K. Chandrashekhara

Dr. V. A. Samaranayake

© 2015

Tarek A Mohammed Hamad

All Rights Reserved

PUBLICATION DISSERTATION OPTION

This dissertation has been formatted per Missouri University of Science and Technology specifications. It consists of the following articles that have been submitted for publication as follows:

Pages 5 to 33 “Study of a molten carbonate fuel cell combined heat, hydrogen and power system”. It has been accepted and published in Energy.

Pages 37 to 58 “Study of combined heat, hydrogen and power system based on a molten carbonate fuel cell fed by biogas produced by anaerobic digestion”. It has been accepted and published in Energy Conversion and Management.

Pages 61 to 78 “Hydrogen recovery, cleaning, compression, storage, dispensing, distribution system and End-Uses on the university campus from combined heat, hydrogen and power system”. It has been accepted and published in International Journal of Hydrogen Energy.

Pages 80 to 94 “Hydrogen production and End-Uses from combined heat, hydrogen and power system by using local resources”. It has been accepted and published in Renewable Energy.

Pages 96 to 109 “Study of a molten carbonate fuel cell combined heat, hydrogen and power system: End-use application”. It has been accepted and published in Case Studies in Thermal Engineering..

Pages 111 to 129 “Solid waste as renewable source of energy: current and future possibility in Libya”. It has been accepted and published in Case Studies in Thermal Engineering.

ABSTRACT

The objective of this work has two major tasks that investigation the use of CHHP system at the Missouri University of Science and Technology (Missouri S&T) campus and studying solid waste as renewable source of energy: current and future possibility in Libya. Task one has three major topics. In Topic I, Design of Combined Hydrogen, Heat and Power (CHHP) system for the campus using local resources and treated biogas can be used to generate CHHP using a Molten Carbonate Fuel Cell (MCFC). In Topic II, hydrogen recovery and cleaning system, Heat recovery and electric power usage, hydrogen compression, storage, and dispensing/distribution system, electricity use and economic benefits of the system in operation, and thermal use. In Topic III, utilization of hydrogen production, hydrogen end-uses, CHHP hydrogen output, and hydrogen application consider but not used in the design. In task 2, generation of solid waste in Libya, overview of Waste-to-energy (WTE) conversions, solid waste management, WTE benefits and challenges in Libya. Results for Tasks I and II have been presented.

ACKNOWLEDGMENTS

I wish to express my sincere appreciation to my thesis committee, including Dr. Ashok Midha, Dr. John Sheffield, Dr. Robert G. Landers, Dr. K. Chandrashekhara, and Dr. V. A. Samaranayake for their valuable advice and support.

My deepest gratitude goes to both my advisor Dr. Ashok Midha and my co-advisor Dr. John Sheffield for their continuous guidance, encouragement throughout this thesis work. Their hard working and rigorous scientific attitude has influenced every aspect of my life. As my co-advisor, he demonstrated understanding, patience and confidence in my whole research.

I wish to acknowledge the Hydrogen Education Foundation for their support of the annual Hydrogen Student Design Contest which challenges university students to design hydrogen energy applications for real-world use.

Finally, I wish to express my deep gratitude to my parents, brother, Osama, especially, to my wife, Mabroka, for their encouragement, understanding, patience and love.

TABLE OF CONTENTS

	Page
PUBLICATION DISSERTATION OPTION	iii
ABSTRACT.....	iv
ACKNOWLEDGMENTS	v
LIST OF ILLUSTRATIONS.....	xii
LIST OF TABLES.....	xiv
NOMENCLATURE	xvi
SECTION	
1. INTRODUCTION.....	1
PAPERS	
I STUDY OF A MOLTEN CARBONATE FUEL CELL COMBINED HEAT, HYDROGEN AND POWER SYSTEM.....	5
ABSTRACT.....	5
1. INTRODUCTION.....	6
2. RESOURCE ASSESSMENT.....	7
2.1. FEEDSTOCK SOURCE IDENTIFICATION.....	7
3. EXPERIMENTAL PROCEDURE.....	9
3.1. DIRECT FUEL CELL (DFC [®]) TECHNOLOGY STATUS	9
3.2. CHHP SYSTEM TECHNICAL DESIGN.....	9
3.3. ANAEROBIC DIGESTION SYSTEM	10
3.4. GAS TREATMENT SYSTEM AND FUEL STORAGE	11
3.5. DFC1500 [™] FUELCELL POWER PLANT.....	12
3.5.1. Anode Outlet Gas (AOG) Calculations.....	13
3.5.2. Hydrogen Recovery and Cleaning System.....	15
3.5.3. Heat Recovery and Electric Power Usage.....	18
3.6. HYDROGEN COMPRESSION, STORAGE, DISPENSIN/DISTRIBUTION SYSTEM	18
4. RESULTS AND DISCUSSION	20

4.1. ELECTRICITY USE AND ECONOMIC BENEFITS OF THE SYSTEM IN OPERATION	20
4.2. THERMAL USE.....	21
4.3. UTILIZATION OF HYDROGEN PRODUCTION.....	22
5. ENERGY SAVING AND ENVIRONMENTAL CALCULATION	26
5.1. FUEL CONSUMPTION BY CHHP SYSTEM.....	26
5.2. FUEL CONSUMPTION IN TRANSPORTING FEEDSTOCK.....	27
5.3. SYSTEM ELECTRICITY OUTPUT AND AVOIDED CENTRAL STATION FUEL AND EMISSIONS.....	27
5.4. CHHP HYDROGEN OUTPUT AND AVOIDED FUEL EMISSIONS	28
6. CONCLUSION	32
ACKNOWLEDGEMENTS.....	32
REFERENCES.....	33
II STUDY OF COMBINED HEAT, HYDROGEN AND POWER SYSTEM BASED ON A MOLTEN CARBONATE FUEL CELL FED BY BIOGAS PRODUCED BY ANAEROBIC DIGESTION.....	37
ABSTRACT.....	37
1. INTRODUCTION.....	38
2. RESOURCE ASSESSMENT.....	39
2.1. FEEDSTOCK SOURCE IDENTIFICATION.....	39
3. EXPERIMENTAL PROCEDURE.....	41
3.1. DFC [®] TECHNOLOGY STATUS AND DFC1500TM FUELCELL POWER PLANT.....	41
3.2. CHHP SYSTEM TECHNICAL DESIGN.....	42
3.2.1. Site Plan and Location.....	42
3.3. ANAEROBIC DIGESTION SYSTEM	42
3.4. GAS TREATMENT SYSTEM AND FUEL STORAGE	45
3.5. ANODE OUTLET GAS (AOG) CALCULATIONS.....	47
3.6. HYDROGEN RECOVERY AND CLEANING SYSTEM.....	49
3.7. HEAT RECOVERY AND ELECTRIC POWER USAGE	51
3.8. HYDROGEN COMPRESSION, STORAGE, DISPENSING/ DISTRIBUTION SYSTEM	52
4. RESULTS AND DISCUSSION	53

4.1. ENERGY END-USES ON THE UNIVERSITY CAMPUS FROM CHHP SYSTEM.....	53
4.2. ELECTRICITY USE	53
4.3. THE HEAT RECOVERY SYSTEM USE	54
4.4. UTILIZATION OF HYDROGEN PRODUCTION.....	55
5. CONCLUSION	57
ACKNOWLEDGEMENTS.....	57
APPENDIX A. SUPPLEMENTAL DATA.....	57
REFERENCES.....	58
III HYDROGEN RECOVERY, CLEANING, COMPRESSION, STORAGE, DISPENSING, DISTRIBUTION SYSTEM AND END-USES ON THE UNIVERSITY CAMPUS FROM COMBINED HEAT, HYDROGEN AND POWER SYSTEM.....	61
ABSTRACT.....	61
1. INTRODUCTION.....	62
2. DFC [®] TECHNOLOGY STATUS.....	63
2.1. ANAEROBIC DIGESTION SYSTEM	63
2.2. GAS TREATMENT SYSTEM AND FUEL STORAGE	64
2.3. DFC1500TM FUELCELL POWER PLANT.....	65
2.3.1. Anode Outlet Gas (AOG) Calculations.....	66
2.3.2. Hydrogen Recovery and Cleaning System.....	67
2.3.3. Heat Recovery.	70
2.4. HYDROGEN COMPRESSION, STORAGE, DISPENSING / DISTRIBUTION SYSTEM.....	70
3. RESULTS AND DISCUSSION	72
3.1. HYDROGEN END-USES.....	72
3.2. CHHP HYDROGEN OUTPUT.....	75
4. CONCLUSION	77
ACKNOWLEDGEMENTS.....	77
APPENDIX A. SUPPLEMENTAL DATA.....	77
REFERENCES.....	78

IV HYDROGEN PRODUCTION AND END-USES FROM COMBINED HEAT, HYDROGEN AND POWER SYSTEM BY USING LOCAL RESOURCES.....	80
ABSTRACT.....	80
1. INTRODUCTION.....	81
2. RESOURCE ASSESSMENT.....	82
2.1. FEEDSTOCK SOURCE IDENTIFICATION.....	82
3. EXPERIMENTAL PROCEDURE.....	84
3.1. DFC® TECHNOLOGY STATUS.	84
3.2. ANAEROBIC DIGESTION SYSTEM	84
3.3. DFC1500™ FUELCELL POWER PLANT.....	86
3.3.1. AOG Calculations	86
3.3.2. Hydrogen Recovery and Cleaning System.....	87
3.4. HYDROGEN COMPRESSION, STORAGE, DISPENSING /DISTRIBUTION SYSTEM	89
4. RESULTS AND DISCUSSION	91
4.1. HYDROGEN END-USES.....	91
5. CONCLUSION	93
ACKNOWLEDGEMENTS.....	93
APPENDIX A. SUPPLEMENTAL DATA.....	93
REFERENCES.....	94
V STUDY OF A MOLTEN CARBONATE FUEL CELL COMBINED HEAT, HYDROGEN AND POWER SYSTEM: END-USE APPLICATION.....	96
ABSTRACT.....	96
1. INTRODUCTION.....	97
2. RESOURCE ASSESSMENT.....	98
2.1. FEEDSTOCK SOURCE IDENTIFICATION.....	98
3. EXPERIMENTAL PROCEDURE.....	99
3.1. CHHP SYSTEM TECHNICAL DESIGN.....	99
3.2. ANAEROBIC DIGESTION, GAS TREATMENT SYSTEM AND FUEL STORAGE.....	99
3.3. DFC1500™ FUELCELL POWER PLANT.....	100

3.3.1. AOG Calculations	101
3.3.2. Hydrogen Recovery and Cleaning System.....	102
3.4. HYDROGEN COMPRESSION, STORAGE, DISPENSING /DISTRIBUTION SYSTEM	104
4. RESULTS AND DISCUSSION	105
4.1. ELECTRICITY USE	105
4.2. THERMAL AND HYDROGEN USE.....	106
5. CONCLUSION	108
ACKNOWLEDGEMENTS.....	108
REFERENCES.....	109
VI SOLID WASTE AS RENEWABLE SOURCE OF ENERGY: CURRENT AND FUTURE POSSIBILITY IN LIBYA.....	111
ABSTRACT.....	111
1. INTRODUCTION.....	112
2. SOLID WASTE GENERATION IN LIBYA	114
2.1. MUNICIPAL SOLID WASTE.....	114
2.2. INDUSTRIAL SOLID WASTE.....	116
2.3. HEALTHCARE SOLID WASTE	117
2.3.1. Generation and Classification of both Hospital and Clinical Waste in Libya.....	118
3. SOLID WASTE MANAGEMENT.....	120
3.1. THE OPEN DUMP METHOD.....	120
3.2. LANDFILL MODE	120
3.3. COMPOSTING MODE.....	121
3.4. RECOVERY AND RECYCLING MODE.....	121
4. WASTE-TO-ENERGY (WTE) CONVERSIONS.....	122
4.1. BIOCHEMICAL CONVERSION	122
4.2. THERMOCHEMICAL CONVERSION	123
4.3. MECHANICAL EXTRACTION	123
4.3.1. Electricity Generation.....	124
4.3.2. Heat and Steam Generation.....	124

4.3.3. Transportation Fuel	124
5. RESULTS AND DISCUSSION	125
5.1. WTE BENEFITS IN LIBYA.....	125
5.2. WTE CHALLENGES.....	126
6. CONCLUSION	128
ACKNOWLEDGEMENTS.....	128
REFERENCES.....	129
SECTION	
2. CONCLUSIONS	131
BIBLIOGRAPHY.....	132
VITA.....	134

LIST OF ILLUSTRATIONS

	Page
SECTION	
Figure. 1.1. Fossil fuel reserves and production of Libya vs. time.....	3
Figure. 1.2. Sunshine duration and insolation for Libya.....	4
PAPER I	
Figure 1. Flow diagram for digester and biogas production.....	10
Figure 2. Flow balance diagram.....	12
Figure 3. Internal reforming DFC [®] technology.....	13
Figure 4. Hydrogen recovery and purification.....	16
Figure 5. Hydrogen compression, storage, and dispensing.....	19
Figure 6. Hydrogen application and usage on the university campus.....	23
Figure 7. Personal transportation.....	24
Figure 8. Backup power applications.....	24
Figure 9. Fuel cell portable power application.....	25
PAPER II	
Figure 1. Site plan with anaerobic digester, CHHP system and hydrogen fuelling station.....	43
Figure 2. Flow diagram for digester and biogas production.....	45
Figure 3. Flow balance diagram.....	47
Figure 4. Internal reforming DFC [®] technology.....	48
Figure 5. Hydrogen recovery and purification.....	50
PAPER III	
Figure 1. Biogas treatment process diagram.....	65
Figure 2. Internal reforming DFC [®] technology.....	66
Figure 3. Hydrogen recovery and purification.....	68
Figure 4. Hydrogen compression, storage, and dispensing.....	71
Figure 5. Percentage daily range hydrogen application and usage on the university campus.....	72
Figure 6. Personal transportation.....	73
Figure 7. Hydrogen powered mobility applications.....	74
Figure 8. Hydrogen Fuel cell portable power application.....	75

PAPER IV

Figure 1. Flow diagram for digester and biogas production.....	85
Figure 2. Flow balance diagram.....	85
Figure 3. Internal reforming DFC [®] technology	86
Figure 4. Hydrogen recovery and purification.....	88
Figure 5. Hydrogen compression, storage, and dispensing	90
Figure 6. Percentage daily range hydrogen application and usage on the university campus	91

PAPER V

Figure 1. Flow diagram for digester and biogas production.....	100
Figure 2. Internal reforming DFC [®] technology	101
Figure 3. Hydrogen recovery and purification.....	102
Figure 4. Hydrogen compression, storage, and dispensing	104
Figure 5. Hydrogen application and usage on the university campus	107

PAPER VI

Figure 1. Fossil fuel reserves and production of Libya vs. time.....	113
Figure 2. Sunshine duration and insolation for Libya.....	113
Figure. 3. MSW Composition survey in Libya.....	116
Figure. 4. Classification of general healthcare waste in Libya vs mass%	118
Figure 5. Classification of hazardous healthcare waste in Libya vs mass%	119
Figure 6. Methods of waste disposal in Libya	120
Figure 7. Simplified flow diagram of a general anaerobic digestion plant based of MSW	122
Figure 8. Energy equivalence of methane.....	125
Figure 9. Fossil fuel and hydrogen price predictions vs. time	127

LIST OF TABLES

	Page
PAPER I	
Table 1. Pugh Chart for feedstock	7
Table 2. Feedstock Availability, Collection, and Transportation	8
Table 3. Anode outlet gas composition.....	14
Table 4. Anode outlet gas flowrate of the DFC1500 TM unit.....	15
Table 5. Flow of gases at different sections of the system	17
Table 6. Power demand and energy consumption	21
Table 7. Thermal energy available for heat recovery from the DFC1500 TM CHHP system.....	22
Table 8. Fuel used for transporting feedstock.....	28
Table 9. Avoided conventional fuel details	30
PAPER II	
Table 1. Pugh Chart for feedstock	39
Table 2. Feedstock availability, collection, transportation and storage.....	40
Table 3. Anode outlet gas composition.....	49
Table 4. Anode outlet gas flowrate of the DFC1500 TM unit.....	49
Table 5. Flow of gases at different sections of the system	51
Table 6. Power demand and energy consumption	54
Table 7. Thermal energy available for heat recovery from the DFC1500 TM CHHP system.....	55
Table 8. Hydrogen applications and usage on the university campus	56
PAPER III	
Table 1. Flow of gases at different sections of the system	69
Table 2. Avoided conventional fuel details	76
PAPER IV	
Table 1. Feedstock availability, collection, transportation and storage.....	83
PAPER V	
Table 1. Flow of gases at different sections of the system	103
Table 2. Power demand and energy consumption	106

Table 3. Thermal energy available for heat recovery from the DFC1500 TM CHHP system.....	107
--	-----

PAPER VI

Table 1. Waste composition category	115
---	-----

Table 2. Quantities of industrial waste and composition category	117
--	-----

Table 3. Recycling capacity	121
-----------------------------------	-----

NOMENCLATURE

Symbol	Description
CHHP	Combined Hydrogen, Heat and Power system
DFC	Direct Fuel Cell
MSW	Municipal Solid Waste
RMU	Rolla Municipal Utilities
MTNF	Mark Twain National Forest
AOG	Anode Outlet Gas
HEX.W.G	Heat Exchanger Water and Gas
AGO	Anode Gas Oxidizer
E-BOP	Electrical Balance of the Plant
MBOP	Mechanical Balance of the Plant
CHP	Combined Heat and Power
UPS	Uninterruptable Power Supply
OAR	Outdoor Activities and Rental
MCFC	Molten Carbonate Fuel Cell
AAVG	Advanced Aero Vehicle Group
VS	Volatile Solids
GHG	Greenhouse Gas

1. INTRODUCTION

The Missouri University of Science and Technology (Missouri S&T) campus in Rolla, Missouri, USA is a relatively small campus with 1.15 km² and approximately 6500 students on campus. The university is one of the City of Rolla's largest electric power consumers with a peak demand of 6.36 MWe and annual electric energy consumption of 2.55×10^6 kWh/yr. Currently, electrical power for the university campus is purchased from RMU (Rolla municipal utilities) and distributed from the substation and switchgear located at the campus power plant. In addition, the university thermal power plant generates electricity with a backpressure steam turbine, accounting for an additional 10% of electricity. The power plant, built in 1945, is fueled by coal and wood chips and provides steam to the university campus for space heating, chilled water via absorption chillers and backpressure steam turbines. Biogas produced by anaerobic digestion of wastewater, organic waste, agricultural waste, and industrial waste is a potential source of renewable energy. Treated biogas can be used to generate CHHP (combined heat, hydrogen and power) using a molten carbonate fuel cell. The paper investigates the use of a CHHP system at (Missouri S&T) campus. The power generated by the CHHP system is used at various locations on the campus to reduce the total electric power purchased and minimize air pollution to benefit overall community health [1- 4]. In addition, the CHHP system has higher efficiency than other distributed generation plants of similar size [5, 6]. The hydrogen generated is used to power different applications on the university campus including personal transportation, back-up power, portable power, and mobility/utility applications. Locally available feedstocks near the Missouri S&T campus that can be used for biogas production were identified [7 - 9]. An energy flow and resource availability study was performed to identify the type and source of feedstock required to continuously run the CHHP system to produce maximum capacity of electricity, heat recovery and hydrogen [10].

According to the International Energy Outlook 2013, released by the U.S. Energy Information Administration (EIA), worldwide energy-related carbon dioxide emissions will rise from about 31 billion metric tons in 2010 to 36 billion metric tons in 2020. The carbon dioxide emissions will further grow to 45 billion metric tons by 2040, resulting in a total of 46 percent increase. One of the major contributors to the

emissions will be in the exhaust gases released from the vehicles. Therefore, it can be said that by employing zero-carbon print vehicle fuel a significant change can be observed in the carbon-dioxide emission levels. Research in the area of alternative fuels, renewable and nonrenewable, has demonstrated its applicability in the vehicle power train section, however, in a laboratory environment. With the available research findings, and considering the need of time, steps have to be taken towards the development of a fueling infrastructure. From the available alternative fuels, hydrogen has shown tremendous potential. Hydrogen not only provides cleaner energy, but also, is easy to transport, allowing centralized production, mimicking a gasoline fueling infrastructure. In order to prove the market potential of hydrogen, and test the business case, mobile drop-in units have been an ideal mode of the introduction of hydrogen fueling infrastructure. This paper provides a new design of such a drop-in hydrogen fueling station.

Libya, located in North Africa between 26 latitude north and 17 longitudes east, extends over 1,759,540 km² [11]. It is bordered by the Mediterranean Sea to the north, Egypt to the east, Sudan to the southeast, Chad and Niger to the south, and Algeria and Tunisia to the west. Both the Mediterranean Sea and the desert affect Libya's weather. In the winter, the weather is cold, with some rain on the coast. The Sahara is very dry and hot in the summer and cold and dry in the winter [11]. Temperatures in the summer can reach 50°C during the day; through they are typically closer to 40°C. The average annual temperature is approximately 20.5°C. The mean annual rainfall varies from 180 mm (in the east) to 90 mm (in the west). Libya's population has nearly doubled over the last 10 years. Libyan youth represent more than 50% of the current population. This situation places a great deal of pressure on energy demands, food supplies, and even the environment by increasing the generation of waste and residues. For the last two decades, Libya had depended on fossil fuels, petroleum, and natural gas for its income, energy, industrialization, and development. Although some efforts have been made to diversify the sources of income, to a large extent, fossil fuels have continued to play a major role in the country's economy. Unfortunately, the fossil fuels available in this area are becoming depleted (Fig. 1.1). A total dependence on oil and gas can lead to serious consequences [12]. Out of the renewable energy sources, such as solar, wind, and

wastes, conversion of waste feedstocks to H₂. Its useful products such as electricity, heat, reduce fossil fuel usage, and greenhouse gas emissions at the Libya. Solar energy stands out as the most promising. Libya experiences, on 3400 h of sunshine per year; it maintains an average insolation of approximately 2200kWh/m² annually (Fig. 1.2) [12, 13]. More than 80% of the land is unused. This land might not be used for either agriculture or any other foreseeable purpose than solar energy collection. Solid waste is one of most important sources of biomass potential in Libya. Biomass is a by-product from human activities that is characterized by negative impacts that may affect man and the environment when disposed of in an inappropriate way. This paper investigates whether or not solid waste can be used as a source of bioenergy in Libya.

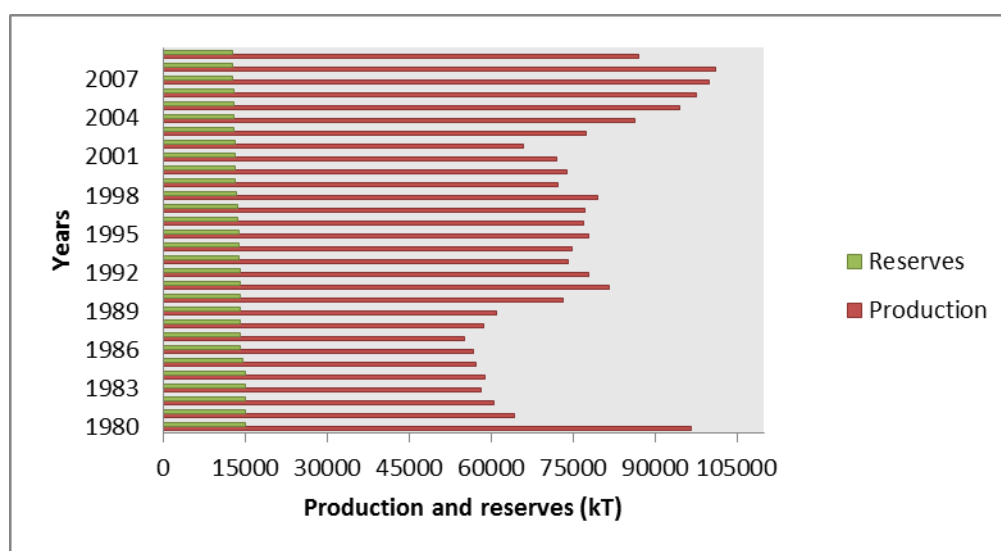

Figure. 1.1. Fossil fuel reserves and production of Libya vs. time

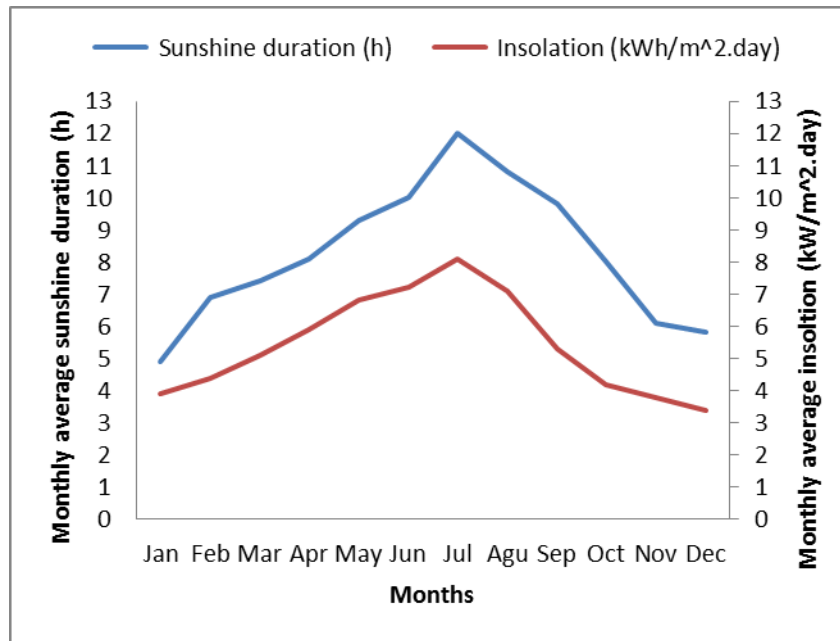

Figure. 1.2. Sunshine duration and insolation for Libya

PAPER

**I STUDY OF A MOLTEN CARBONATE FUEL CELL COMBINED HEAT,
HYDROGEN AND POWER SYSTEM**

Tarek A. Hamad, John W. Sheffield

Department of Mechanical and Aerospace Engineering, Missouri University of Science
and Technology, 400 W 13th Street, Rolla, MO 65409-0050, USA

Received 26 August 2013

Received in revised form 25 July 2014

Accepted 5 August 2014

ABSTRACT

To address the problem of fossil fuel usage and high greenhouse gas emissions at the Missouri University of Science and Technology campus, using of alternative fuels and renewable energy sources can lower energy consumption and greenhouse gas emissions. Biogas, produced by anaerobic digestion of wastewater, organic waste, agricultural waste, industrial waste, and animal by-products is a potential source of renewable energy. In this work, we have discussed the design of combined heat, hydrogen and power (CHHP) system for the campus using local resources. An energy flow and resource availability study is performed to identify the type and source of feedstock required to continuously run the fuel cell system at peak capacity. Following the resource assessment study, the team selects FuelCell Energy direct fuel cell (DFC) 1500TM unit as a molten carbonate fuel cell. The CHHP system provides electricity to power the university campus, thermal energy for heating the anaerobic digester, and hydrogen for transportation, back-up power and other needs. In conclusion, the CHHP system will be able to reduce fossil fuel usage, and greenhouse gas emissions at the university campus.

Keywords: A molten carbonate, renewable energy, anaerobic digestion, energy End-Uses

1. INTRODUCTION

The Missouri University of Science and Technology (Missouri S&T) campus in Rolla, Missouri, USA is a relatively small campus with 1.15 km² and approximately 6,500 students on campus. The university is one of the City of Rolla's largest electric power consumers with a peak demand of 6.36 MW_e and annual electric energy consumption of 2.55×10^6 kWh/yr. Currently, electrical power for the university campus is purchased from Rolla municipal utilities (RMU) and distributed from the substation and switchgear located at the campus power plant. In addition, the university thermal power plant generates electricity with a back pressure steam turbine, accounting for an additional 10% of electricity. The power plant, built in 1945, is fueled by coal and wood chips and provides steam to the university campus for space heating, chilled water via absorption chillers and back pressure steam turbines. Biogas produced by anaerobic digestion of wastewater, organic waste, agricultural waste, and industrial waste is a potential source of renewable energy. Treated biogas can be used to generate combined heat, hydrogen and power (CHHP) using a molten carbonate fuel cell. The paper investigates the use of a CHHP system at (Missouri S&T) campus. The power generated by the CHHP system is used at various locations on the campus to reduce the total electric power purchased and minimize air pollution to benefit overall community health [1–4]. In addition, the CHHP system has higher efficiency than other distributed generation plants of similar size [5, 6]. The hydrogen generated is used to power different applications on the university campus including personal transportation, backup power, portable power, and mobility/utility applications. Locally available feedstocks near the Missouri S&T campus that can be used for biogas production were identified [7–9]. An energy flow and resource availability study was performed to identify the type and source of feedstock required to continuously run the CHHP system to produce maximum capacity of electricity, heat recovery and hydrogen [10].

2. RESOURCE ASSESSMENT

2.1. FEEDSTOCK SOURCE IDENTIFICATION

During the assessment, “locally available feedstock” was defined as one which is within 20 km of Rolla. The largest source of locally available feedstock is municipal solid waste (MSW) averaging 60 tons/day. Of this, approximately 33% is organic waste including 17% food waste. The campus plans to partner with the City of Rolla and will start an “Organic Waste Collection Program” to collect organic waste. Currently, the city offers residential curbside collection of recyclable materials at no extra cost. The second largest local resource is the rejects and waste resulting from change over at the Royal Canin dog and cat nutrition company. Their waste is currently disposed at a landfill facility 40 km from the company.

Potential feedstock from the campus includes food waste and sanitary sewer. Food waste collected daily is mixed with the trash and the sanitary sewer and is connected to the city’s main sewer lines. A Pugh chart is created to compare different feedstock and is shown in Table 1 [11].

Table 1. Pugh Chart for feedstock

Key Criteria	Weight	MSW	Dog food waste	Food waste	Wood chips	Grape skin	Vines	Brewery waste	Waste water
Availability	4	4	4	3	4	2	2	4	4
Ease of collection	3	3	4	4	4	4	3	4	4
Ease of digestion	4	3	4	4	1	4	2	4	3
Energy value	3	3	4	4	2	4	2	4	2
Total		46	56	52	38	48	31	56	46

Methods for feedstock collection, transportation, and storage were also identified and are tabulated in Table 2 Feedstock, except waste water, will be stored on campus at the feedstock storage facility (Facility A) and will undergo anaerobic digestion at this location. Collection and anaerobic digestion of waste water will be off-campus at the treatment plant (Facility B).

Table 2. Feedstock Availability, Collection, and Transportation

Type of feedstock	Source	Collection		Transportation
		Frequency	Collection point	
Dog and cat food waste	Royal Canin	daily	warehouse	semi-trailer
Food waste	university courts	daily	food court	pickup truck
Wood chips	university power plant	daily	delivered at site	trailer truck
Waste water	SE Wastewater Treatment	daily	delivered at site	used at facility
MSW	Rolla MSW	weekdays	organic waste collection program	trash truck
Brewery waste	Public House Brewery	weekly	brewery	pickup truck
Grape skin, rice hull and vines	St. James Winery	seasonal	winery/vineyard	semi-trailer
Timber	MTNF ^a	seasonal	MTNF	trailer truck

3. EXPERIMENTAL PROCEDURE

3.1. DIRECT FUEL CELL (DFC[®]) TECHNOLOGY STATUS

FuelCell Energy offers three DFC[®] products; the DFC 300[™], DFC 1500[™], and DFC 3000[™], which are 350 kW, 1.4 MW, and 2.8 MW, power plants, respectively. The DFC[®] 1500[™] matches up well with the needs of a wastewater treatment plant, or a food processing facility where methane produced by anaerobic digestion can be efficiently utilized to produce electricity.

The DFC[®] technology offers higher net electrical efficiency and a cleaner exhaust stream when operating on biogas from an anaerobic digester than any competing conventional technology such as reciprocating engines or gas turbines. The DFC[®] systems also have a good heat-to-power ratio for support of digester operations.

3.2. CHHP SYSTEM TECHNICAL DESIGN

The design discussed in this paper has three major systems: (i) anaerobic digestion system, (ii) CHHP system consisting of a DFC1500[™] fuel cell unit, and (iii) hydrogen compression, storage, and dispensing system [1, 2, 8, 11]. These systems were designed based on the results from the feedstock assessment and the expected biogas production from local resources. It was found that the anticipated methane production after biogas treatment is 260 m³/h with a heat content of 37 MJ/m³. Consequently, a DFC1500[™] unit was selected for the CHHP system for which local resources can provide 90% of the fuel requirements. The daily unmet fuel need will be supplied by natural gas purchased from the local utility company.

The anaerobic digestion system and the CHHP system are sized based on the amount of locally available feedstock and the amount of methane gas generated respectively [12, 13]. The hydrogen recovery, purification, compression, storage, and distribution system are designed based on the hydrogen demand on the university campus and the 65% fuel utilization rate [14–17].

The Feedstock is collected and transported to the storage facility. The storage facility consists of a 30.5 m × 30.5 m steel building to protect the feedstock from the elements. It houses a macerator to chop feedstock larger in diameter than 0.05 m to aid in the methane production rate in the digester. The design employs a 15 kW_e

Taskmaster[®] 1600 shedder from Franklin Miller Inc. to reduce the size of the feedstock [18, 19].

3.3. ANAEROBIC DIGESTION SYSTEM

Digester and biogas production are shown in Fig. 1 [2 – 4, 12] The feedstock from the cement storage bin is transported via a screw feeder to a hygienisation unit where it is heated to 70 °C for one hour to remove all the pathogens [20, 21]. After heating, the feedstock is transported to a 45.4 m³ equalization tank where the biomass is mixed to form a homogenous mixture before being fed into the digester. The specification and details of the digester are tank side water depth 12.8 m, tank wall height (below grade) 14.8 m, tank diameter 30.5 m, cone per tank 892 m³, tank wall thickness 0.30 m, floor slope 1:6, quantity of solids to digester 27×10^3 kg/day, retention time 20 days, Volatile solids concentration 80%, anticipated solids reduction 50%, anticipated gas yield 0.93 m³/kg VS destroyed, anticipated biogas production 425 m³/h, and anticipated natural gas equivalent 260 m³/h. [22–24].

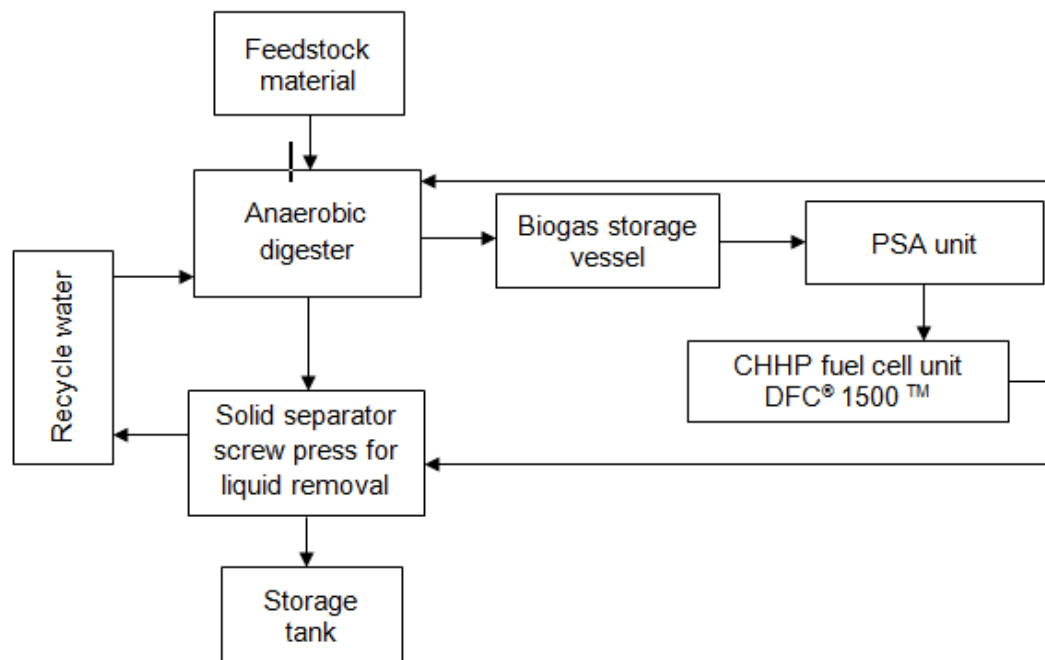

Figure 1. Flow diagram for digester and biogas production

Inside the anaerobic digester, microorganisms act on the organic feedstock to produce biogas, digestate, and water. The anticipated biogas production from the digester is 425 m³/h or 260 m³/h of natural gas equivalent. The digestate from the anaerobic digester is pumped to the storage tank and is stored there until it is ready to be collected and transported to the facility A. The storage tank is also an insulated concrete tank and can also be used to store biogas if the buffer tank holding the biogas is full.

3.4. GAS TREATMENT SYSTEM AND FUEL STORAGE

Biogas from the anaerobic digestion is stored in a buffer tank which supplies biogas to the gas treatment system. The treatment system uses pressure swing adsorption (PSA) technology to separate methane present in the biogas [25, 26]. The design has a total of four adsorbers to ensure a continuous stream of high quality methane. While carbon dioxide (CO₂), hydrogen sulfide (H₂S) and other impurities in one set of tanks are desorbing, biogas will be fed to the second set of tanks for adsorption. The product from this gas treatment system is pipe line quality natural gas which is fed into the fuel cell [27]. The design included the PSA unit for the following reasons [1-5, 10, 11]:

- i. The hydrogen student design competition required us to use the DFC unit for the design purposes. This allowed the competition organizers to evaluate various designs based on the implementation only. The DFC[®] fuel cell units cannot accept H₂S, water (H₂O), and other impurities in its input fuel [28].
- ii. Inlet fuel pressure to the fuel cell should be between 2 – 2.4 bar. If the fuel contains 40% carbon dioxide, it will impact the sizing of the equipment downstream the fuel cell. In other words, the design will require a higher capacity heat exchanger, water - gas shift reactor, and hydrogen purification or separation system [12, 29 –31].
- iii. The biogas output from the digester can vary due to disruption in the feedstock availability or other unforeseeable reasons. In this case, the system will have to use natural gas purchased from utility company to provide any unmet fuel demand by the fuel cell [32, 33]. It was estimated that the systems downstream the fuel cell will run at 78.5% of its normal capacity if the fuel quality changes from 100% biogas to 50% biogas and 50% natural gas.

iv. The product gas from the PSA unit is expected to have an average heat content of 37 MJ/m^3 which is roughly equal to the average heat content of natural gas consumed in Missouri (38 MJ/m^3) through 2007–2010 [34]. The process and flow during the biogas treatment is depicted in Fig. 2 [1, 3, 4]. Biogas treatment process consists of one compression stage, one separation station and a recycle stage, as shown in Fig. 2. The biogas obtained from the anaerobic digester is fed to a compressor that pressurizes the biogas from 1 atm to 7 atm. This pressurized gas is then fed to the PSA unit that reduced the concentration of the contaminants like CO_2 , H_2S , and water, as shown in Fig. 2. The water obtained as a byproduct from the PSA unit is then recycled to the anaerobic digester.

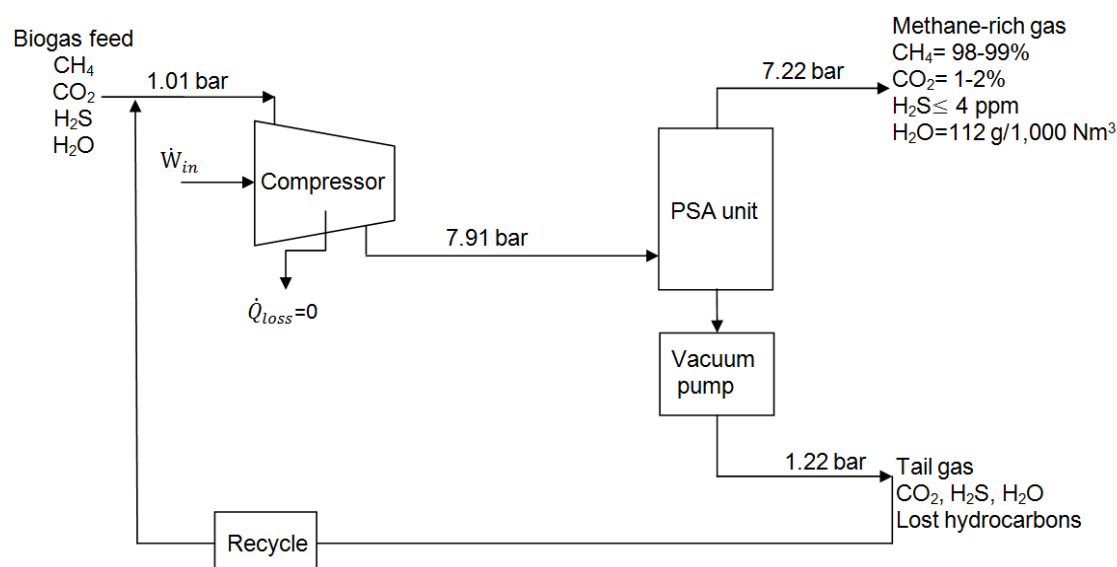

Figure 2. Flow balance diagram

3.5. DFC1500TM FUELCELL POWER PLANT

The anaerobic digester system will be able to supply 90% of fuel for the DFC1500TM unit from locally available feedstock. The remaining 10% fuel required will be purchased from the utility company. In order to accommodate the fluctuations in gas quality, the natural gas used in the design is assumed to contain 98% methane and 2%

carbon dioxide (with an average heating value of 37 MJ/m^3). Figure 3 shows the reactions taking place inside the fuel cell [1-4, 35]. The reactions involved in the fuel cell are explained in the following paragraphs.

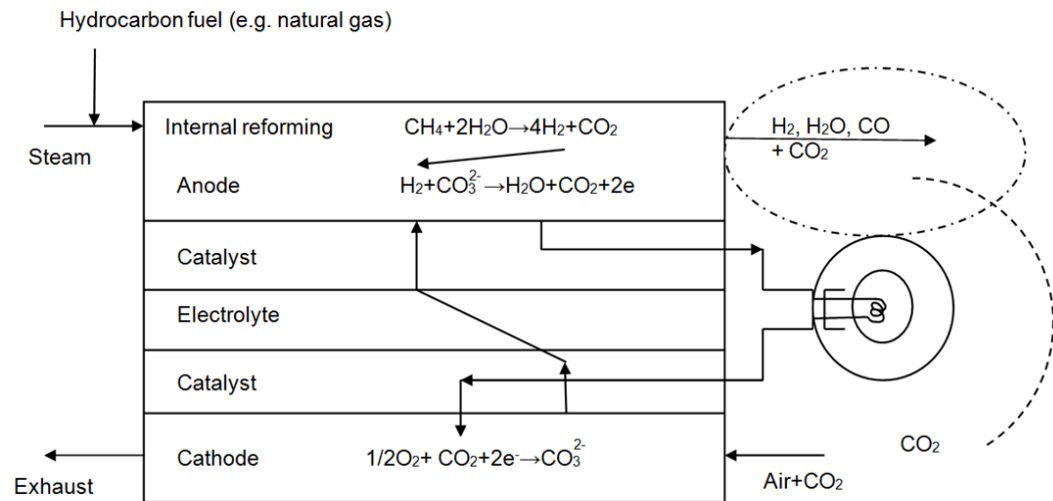

Figure 3. Internal reforming DFC[®] technology

3.5.1. Anode Outlet Gas (AOG) Calculations. The anode outlet gas calculations are made based on the AOG composition calculation document provided by FuelCell Energy [36]. It is assumed that all methane entering the DFC[®] unit is internally reformed and converted to hydrogen and that only 65% (the fuel utilization rate) of the H_2 produced is reacted at the anode to produce electricity. In order to reflect the AOG composition, it is assumed that One third of the 35% hydrogen produced is back-shifted to produce H_2O and CO . Based on these assumptions and the processes taking place inside the fuel cell, the following equations (1 – 5) for every one mole of methane (CH_4) entering the anode side are obtained.

Internal reforming:



Assuming one mole of CH₄ is fed to the DFC[®] system; four moles of hydrogen will be produced. But, only 65% of the hydrogen (i.e. 2.6 moles) reacts at the anode and will result in the following equation.

Corresponding reaction at anode:

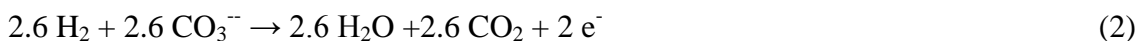

The remaining 35% of the H₂ (1.4 moles) and the entire CO₂ (1 mole) from equation (1) goes directly to the AOG. Combining the products from (2) and 1.4 moles of H₂ and 1 mole of CO₂ from (1) results in the following AOG composition.

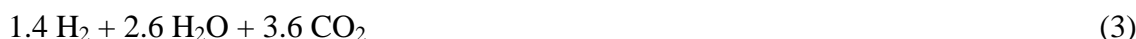

But in reality, another internal reaction takes place in the DFC[®] fuel cell. One third of the H₂ in equation (3) (i.e. 0.47 moles) needs to back-shifted to H₂O and CO resulting in equation (4).



Combining equations (3) and (4) yields the following products:



Hence for every one mole of CH₄ the following AOG composition is obtained as shown in Table 3.

Table 3. Anode outlet gas composition

On a molar percentage basis – NG*	
H ₂ O	40.4%
CO ₂	41.2%
CO	6.2%
H ₂	12.2%
H ₂ O	40.4%
*Assuming 100% CH ₄	

The inlet fuel requirement of the DFC1500TM unit based on 37 MJ/m³ input fuel is calculated and found to be 286 m³/h. Assuming that the input fuel consists of 98% CH₄ and 2% CO₂, 286 m³/h of fuel consists of 198 moles of CH₄ and 4 moles of CO₂.

The actual AOG flowrate corresponding to 198 moles of methane per minute is calculated using equation (5) and is tabulated in Table 4.

Table 4. Anode outlet gas flowrate of the DFC1500TM unit

Gas	mol/min	molar mass	g/min	L/s	density NTP (kg/m ³)
H ₂	156.5	2	315.6	63	0.089
H ₂ O	516.8	18	9,309.6	207.9	0.804
CO	79.10	28	2,216	34.1	1.165
CO ₂	526.90	44	23,187	226	1.842

3.5.2. Hydrogen Recovery and Cleaning System. In order to achieve a CHHP system, hydrogen from the AOG must be recovered, cleaned and distributed from the DFC[®] fuel cell system. The details of the hydrogen recovery and purification process are shown in Fig. 4 [1- 4, 35]. As shown in Fig. 4, the output gas from the DFC unit consists of H₂, CO, CO₂, and water vapor. This gas is then fed to a water gas shift reactor that separates water vapor and CO from the DFC output gas. Further, the CO₂ is then removed to provide pure hydrogen at the output. The CO₂ obtained in the purification process is then recycled to the AGO part of the DFC unit. The recycled CO₂ may contain a small amount of hydrogen, left from the purification process.

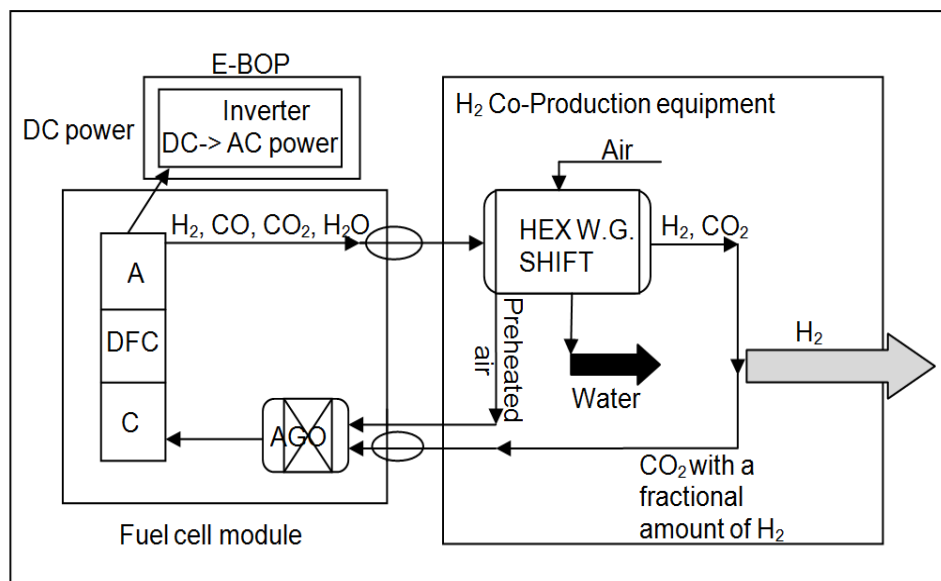

Figure 4. Hydrogen recovery and purification

The AOG outlet pressure is 1.08 bar and outlet temperature to be 600 °C. The AOG is first cooled and pressurized to undergo water-gas reaction.



The entire CO present in the AOG reacts with H₂O to produce an additional 242 kg of H₂ and of 4×10³ kg of CO₂ per day. The water vapor is condensed and recycled to the anode side of the fuel cell for the internal reforming of methane. The amount of water produced during condensation is greater than the fuel cell requirement with the excess water is sent into the sewer. The CO₂ and H₂ coming out of the water-gas shift reactor is cooled and separated using a PSA unit. The hydrogen coming out of the PSA unit is compressed and used for different applications on the university campus. Outside air is preheated using the heat exchanger and is mixed with the CO₂ coming out the PSA unit in anode gas oxidizer (AGO). The mixture is then transferred to the cathode to complete the cathode reaction as shown in equation (7).

Reaction at cathode:



The flow rates of gases at different stages were tabulated in Table 5. These flow rates are necessary to calculate the amount of hydrogen generated, amount of outside air

needed, and amount of exhaust gas. The following assumptions were made during the calculations: (i) H₂ recovery rate from PSA unit is 90%; (ii) N₂ is inert and does not take part in the cathode reactions; (iii) amount of outside air was calculated based on the amount of CO₂ present on the PSA tail gas; (vi) only 70% of CO₂ undergoes reaction to maintain the CO₃²⁻ equilibrium inside the fuel cell. Based on the hydrogen flow rate from the PSA product outlet, the amount of hydrogen generated per day is approximately 650 kg [1, 2].

Table 5. Flow of gases at different sections of the system

Gas	HEX W.G. ^a shift inlet (mol/min)	HEX W.G. shift outlet (mol/min)	PSA product outlet (mol/min)	PSA tail gas (mol/min)	AGO inlet (mol/min)	cathode exhaust (mol/min)
H ₂	156.5	235.6	212	23.6	23.6	23.6
CO ₂	526.9	606	-	606	606	181.8
H ₂ O	516.8	437.7	-	-	-	-
CO	79.1	-	-	-	-	-
O ₂	-	-	-	-	303	90.9
N ₂	-	-	-	-	1,140	1,140

3.5.3. Heat Recovery and Electric Power Usage. The heat energy available for recovery from the DFC1500TM unit working in the CHHP mode is relatively lower than the DFC1500TM unit working in the combined heat and power (CHP) mode. This is due to the losses associated with the hydrogen recovery. Heat is recovered from the fuel cell exhaust gas using an air to water heat exchanger and will be transported to various locations as hot water. The electric power generated by the fuel cells will be the primarily power source for the future Green Hotel and will also be distributed to the university campus [37].

3.6. HYDROGEN COMPRESSION, STORAGE, DISPENSIN/DISTRIBUTION SYSTEM

The design will incorporate the system into the existing hydrogen infrastructure on the university campus. The existing hydrogen station was designed such that it could handle higher volume of hydrogen in the future. Currently, the hydrogen fueling station at the E³ Commons area has an electrolyzer capable of producing 4.2 kg of hydrogen per day, cascade storage tanks that can hold 33 kg of hydrogen at 450 bar, a hydrogen compressor capable of compressing 15 kg of hydrogen per day to 415 bar, and a 350 bar hydrogen dispenser. The entire process of hydrogen compression, storage, dispensing and distribution is shown in Fig. 5 [1 - 4]. Hydrogen from the PSA unit will be transferred into the buffer tank located in the adjacent hydrogen station via pipeline. The buffer tank feeds two compressors; (i) the existing Hydro-Pac C06-10-70/140LX compressor (415 bar) and (ii) the PDC machines (PDC-13-1000-3000) compressor (250 bar). The compressed hydrogen from the Hydro-Pac compressor will be stored in existing storage tanks. Hydrogen from the PDC machine compressor will be used to fill a hydrogen tube trailer and K-cylinder manifold. The end use of hydrogen is discussed in the next section.

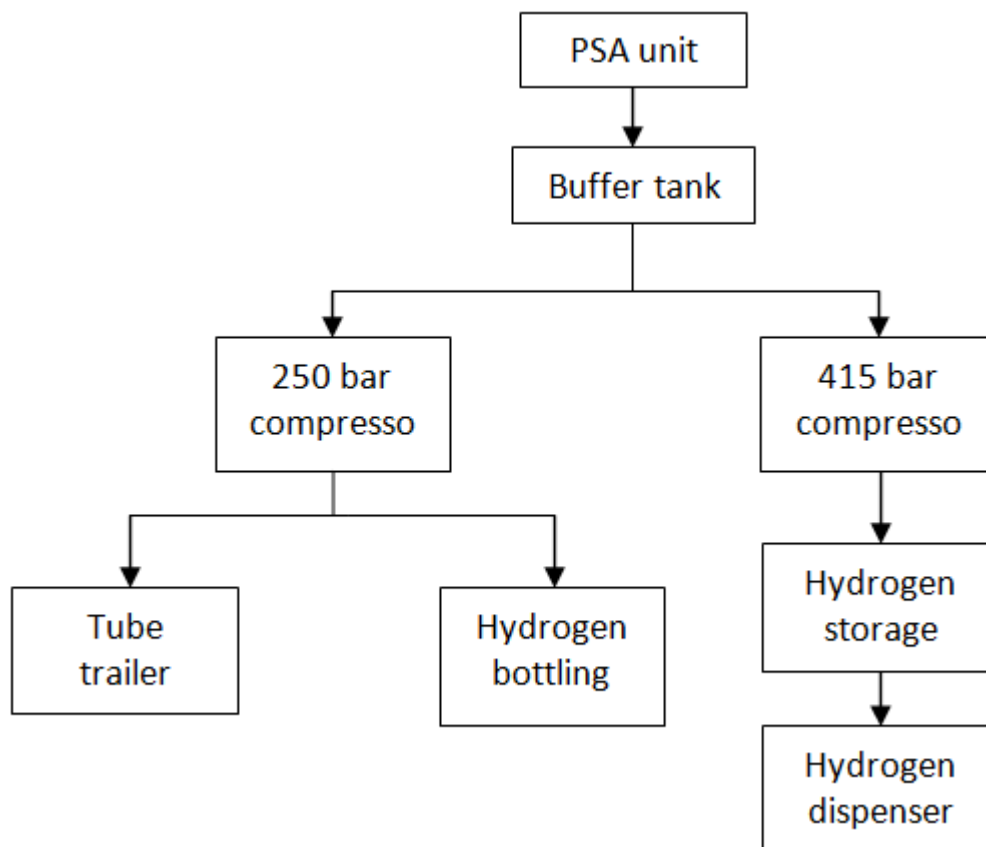

Figure 5. Hydrogen compression, storage, and dispensing

4. RESULTS AND DISCUSSION

4.1. ELECTRICITY USE AND ECONOMIC BENEFITS OF THE SYSTEM IN OPERATION

The electric power output of the DFC1500TM unit operating in the simple cycle CHP mode is 1.4 MW_e. This corresponds to the net power after providing the parasitic loads for its mechanical balance of the plant (MBOP) and energy loss in the electrical balance of the plant (E-BOP). However, there are additional components that require electric power for the DFC1500TM unit operating in CHHP mode. These components, including the heat exchanger for anode outlet gas cooling, the water-gas shift reactor, and the PSA unit for hydrogen purification and operate collectively with the fuel cell unit to form the CHHP system. Based on the power requirements of these components, the net power output from the CHHP system was estimated to be 1.1 MWe. The total electric power requirement of different equipment used in the design is 280 kW_e and is tabulated in Table 6.

Auxiliary loads include site lighting, safety devices, hydrogen dispenser, and electric loads at central control station.

The total net energy production from the CHHP system is 26.4×10^3 kWh per day and the energy demand for on-site use is 4,584 kWh per day. Hence, the CHHP system will be able to provide 22×10^3 kWh per day to the university campus. This corresponds to 27% of the whole campus electricity requirement. Annual plant load factor see equation (8) [38].

$$\text{annual plant load factor} = \frac{9636 \text{ MW.h}}{(366 \text{ days}) \times \left(24 \frac{\text{hours}}{\text{day}}\right) \times (1.4 \text{ MW})} = 0.783 \approx 78\% \quad (8)$$

Table 6. Power demand and energy consumption

Equipment	Max. power rating (kW _e)	Daily operation time (h)	Daily energy consumption (kWh)
Feedstock storage facility	5	12	60
Macerator	15	4	60
Screw feeder	5	4	20
Pump	75	4	300
Hygienization unit	2	4	8
Anaerobic digester	5	24	120
Storage tank	5	24	120
Biogas PSA unit	40	24	960
Hydrogen compressor Comp1	7.5	24	180
Hydrogen compressor Comp2	100	24	2.4×10 ³
Auxiliary loads	20	16	320
Total	279.5	164	4,584

4.2. THERMAL USE

The DFC1500TM unit has 4 GJ/h at 322 °K available for heat recovery while operating in CHP mode. However, the recoverable heat from a DFC1500TM unit operating in CHHP mode is considerably lower than compared to the operating in CHP mode. This is due to the cooling of anode outlet gas, removal of water vapor, hydrogen recovery, and lower flow rate of the exhaust gases. The thermal energy available for heat recovery was calculated based on the cathode exhaust gas composition in Table 4 and equation (9) and is shown in Table 7. The temperature difference of the input and output temperature of the heat recovery system is 322° K [1, 2, 39].

$$Q = m \times C_p (\Delta T) \quad (9)$$

Where: m , C_p and ΔT are the mass flow rate of the gas (kg/h), the specific heat of the gas (kJ/kgK) and the change in temperature of the gas (K) respectively.

Table 7. Thermal energy available for heat recovery from the DFC1500TM CHHP system

Gas	Cathode exhaust (kmol/min)	Mass flow rate (kg/h)	C _p (kJ/kgK)	ΔT (K)	Q flow rate (MJ/h)
H ₂	0.024	2.85	14.32	322	13.1
CO ₂	0.18	196.5	0.84	322	53.4
O ₂	0.91	152.79	0.92	322	45.2
N ₂	1.14	2,188.28	1.04	322	732.8
Total		2,540			844.6

4.3. UTILIZATION OF HYDROGEN PRODUCTION

The hydrogen usage (kg/day) on the university campus may include personal transportation, backup power, portable power, and other mobility applications, equaling to 56, 16, 29, 17, and 5 respectively. The different applications, potential users, and total hydrogen usage per day (123 kg/day) are shown in Fig. 6 [1-3]. The university already holds a large number of forklift, that are either operated by propane or gasoline. These forklifts will be converted to fuel cell operated fork lift. One of the strategic initiatives of the university includes the utilization of carbon free units. The campus may employ electric bikes that can be retrofitted with fuel cells. Similarly, other equipments like, lawn mower, three-wheeler, utility vehicles, electric bus, etc. can be retrofitted with hydrogen fuel cells. The hydrogen required for all of these purposes can be readily supplied by the proposed design, thus empowering the university and making self-sustainable campus.

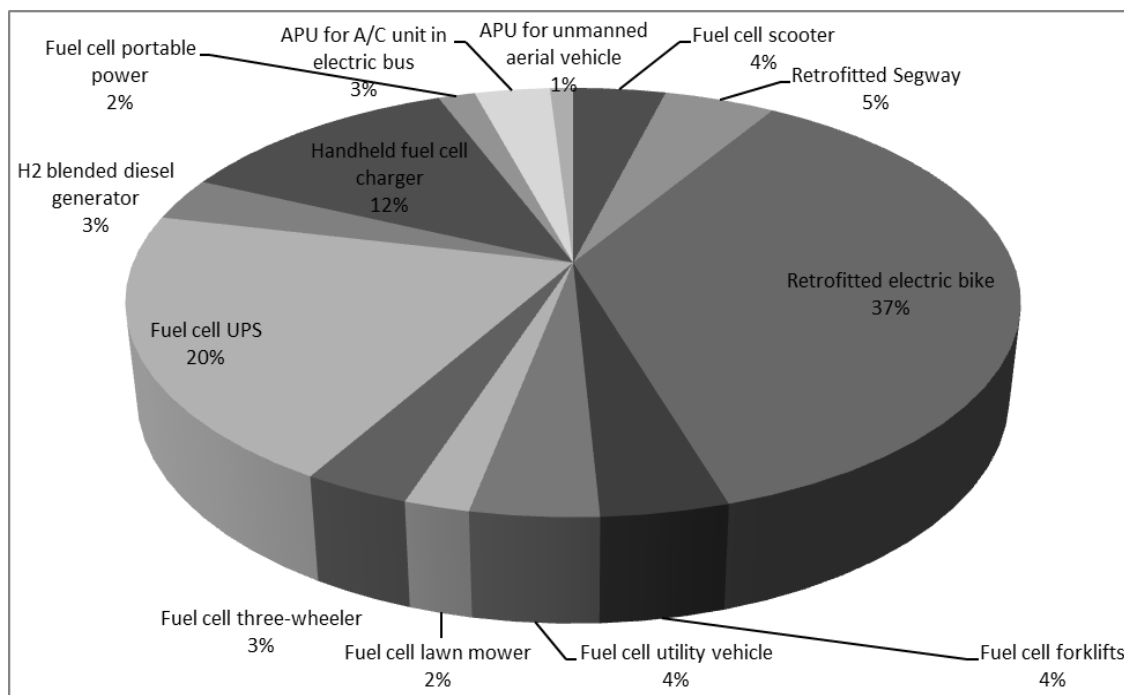

Figure 6. Hydrogen application and usage on the university campus

The major use of the hydrogen on the university campus is for fueling personal transporters. They include fuel cell scooters, Segways and electric bikes retrofitted with fuel cells (Fig. 7) [1]. The Segways and electric bikes will be retrofitted in-house at the hydrogen research and development garage. The retrofitted Segways and bikes will have fuel cells that act as range extenders for the on-board batteries and will recharge it when the state of charge falls below a certain set value.

Providing reliable and high quality power to the IT department is vital. Therefore, the design includes a fuel cell uninterruptible power supply (UPS) unit in the design (Fig. 8). It consists of three 8 kW PEM fuel cells and is designed specifically for larger communications backup power loads within the wireless and wireline telecommunications. These units are outdoor units and have a cabinet to accommodate the hydrogen storage cylinders. Another innovative idea used is the blending of hydrogen with diesel while running backup diesel generators. Blending small percentage of hydrogen with diesel fuel has shown to reduce the total fuel consumption of the generator and reduced emissions.

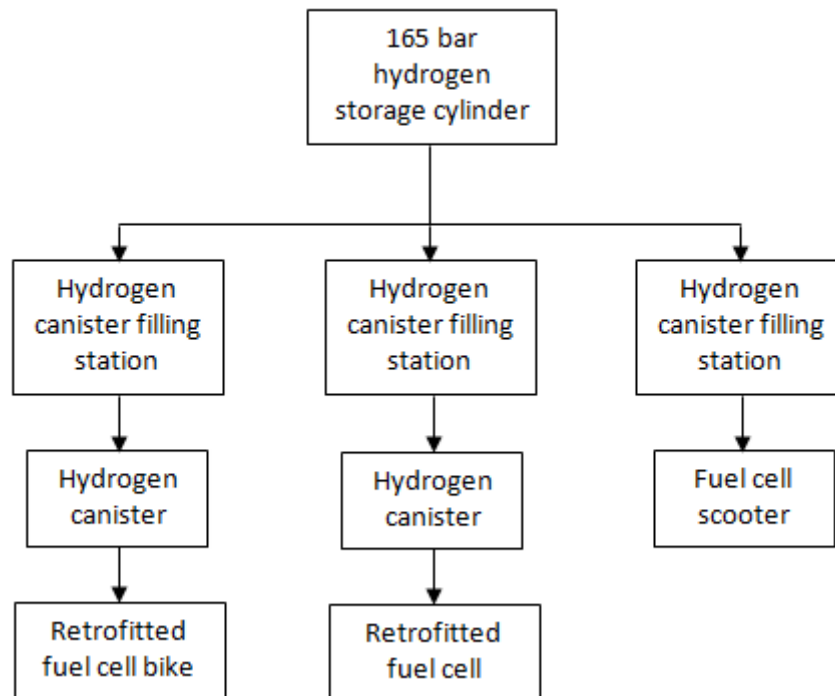

Figure 7. Personal transportation

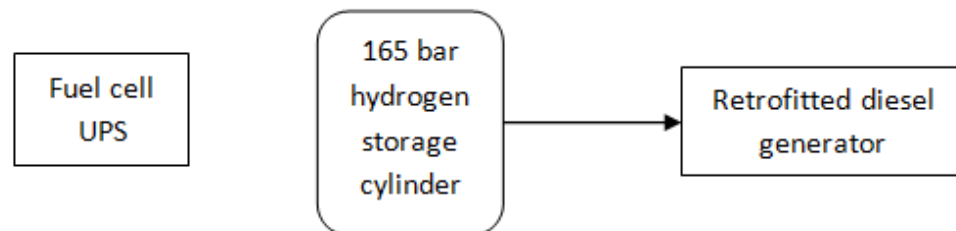

Figure 8. Backup power applications

Portable power and on-the-go recharging of personal electronic appliances such as cell phones, laptops, etc. is desirable in the current technological age. The team has included portable power units (Fig. 9) [1] understanding the demands of the customers on the university campus. The portable power modules and the handheld fuel cell charger will be available to the students, faculty, and staff for checkout from the Department of Student Life office as well the outdoor activities and rental (OAR) office.

The fuel cell portable power packs will be able to reduce the great replacement for the battery operated equipment for camping and outdoor activities.

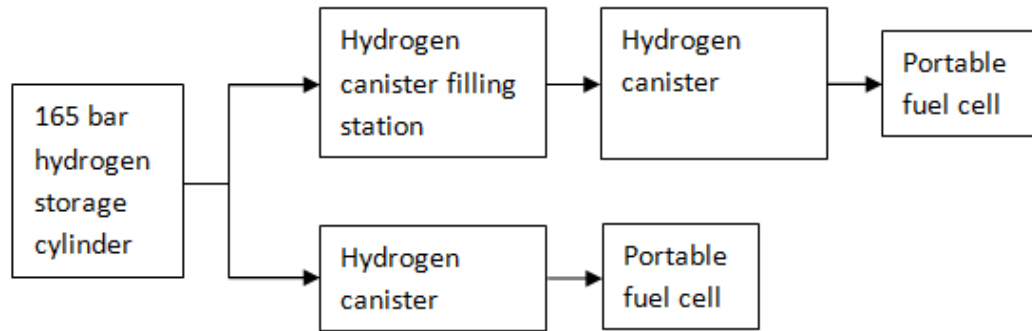

Figure 9. Fuel cell portable power application

5. ENERGY SAVING AND ENVIRONMENTAL CALCULATION

The calculation highlights the energy savings following the use of local organic feedstock. The formulas used in this section are from ‘Energy Savings and Environmental calculation Guidelines’ [39, 40].

The total energy savings can be calculated by the following equation

$$F_S = F_T + F_G + F_H - F_{CHHP} - F_F \quad (10)$$

Where, F_S , F_T , F_G , F_H , F_{CHHP} and F_F are the total fuel savings, fuel use from avoided onsite thermal production, fuel use from avoided purchased grid electricity, fuel use from avoided energy services provided by hydrogen, fuel use by the CHHP system, and fuel use by the feedstock transportation systems respectively.

5.1. FUEL CONSUMPTION BY CHHP SYSTEM

As mentioned in the CHHP system technical design section, Missouri S&T has decided to use one DFC1500TM unit, which requires 285.8 m³/h at 37 MJ/m³. Based on the energy calculations presented in the resource assessment section, the feedstock can supply a total of 260 m³/h scfm of methane at 37 MJ/m³ (extracted from the biogas), 90.7% of the total demand of the system. The remaining 9.3% will be supplied through natural gas from the local utility company, 26.6 m³/h at 155,867 kJ/m³. The input fuel energy content for this architecture can be calculated as,

$$(V_B \times v_B \times E_B + V_N \times v_N \times E_N) \times 10^{-6} = 8.8 \times 10^6 \text{ kJ/h} \quad (11)$$

Where, V , v , and E are the volume fraction, volumetric flow rate in standard cubic meter per hour (m³/h), and the energy content in kJ/m³ respectively. The subscripts B and N identify biogas and natural gas, respectively. As mentioned in the section 4, CHHP output will be used on the university campus. Since the entire system output will be used by the university that has a minimum demand of 25 MW_e. Therefore;

$$FLO_E = TA_{OS} / CS_{max} = 8,760 \text{ h/yr} \quad (12)$$

Thus, the CHHP system fuel consumption can be estimated as,

$$F_{CHHP} = FI_R \times FLO_E = 77.6 \times 10^{12} \text{ kJ/yr} \quad (13)$$

Where, FLO_E , TA_{OS} , CS_{max} and FI_R represent the Equivalent full load operating hrs, Total annual output by the system, Maximum capacity of the system and Fuel Input Rate, respectively.

5.2. FUEL CONSUMPTION IN TRANSPORTING FEEDSTOCK

As per resource assessment section a majority of the feedstock requires transport, and therefore will consume significant amount of conventional fuel. An investigation of them is presented in Table 8. Since the food waste will not require any type of additional transport to the university campus facility, it is not included in this table. The quantity of fuel requires is estimated upon the location of resource and the frequency of pick-ups. Moreover, considering an additional 10% for round-off errors, the fuel required for transporting the feed stock can be estimated to 17 m³/yr of diesel and 0.034 m³/yr of gasoline. Considering the energy content of motor gasoline as 29.6 GJ/L and that of diesel as 33.4 GJ/L, the fuel used for transporting feed stock will be, $F_F = 670 \times 10^9$ kJ/yr.

5.3. SYSTEM ELECTRICITY OUTPUT AND AVOIDED CENTRAL STATION FUEL AND EMISSIONS

As mentioned in the section 3.1., the DFC1500TM generates 1.4 MW_e and the total parasitic loads in the system are approximately 580 kW_e including the losses from the CHHP system. Therefore, the net electrical output per year can be given as,

$$EO_{net} (\text{kWh}) \times EO_G (\text{kWh}) - \sum PL (\text{kWh}) = 7.18 \times 10^6 \text{ kWh} \quad (14)$$

Where, EO_{net} , EO_G and PL are the Net Electrical Output, Gross Electrical Output, and Parasitic Loads respectively.

The total demand of the university campus is 35×10^6 kWh per year. Hence the CHHP system will supply 27% of electrical consumption. Considering the eastern grid transmission losses,

$$ACSE = EOO_{net} / (1 - T\&D_{LF}) = 10.49 \times 10^6 \text{ kWh} \quad (15)$$

Where, $ACSE$, EOO_{net} and $T\&D_{LF}$ are the Avoided Central Station Electricity, Net Electricity Output onsite, and T&D Loss factor respectively. Considering the Southeastern Electric Reliability Council (SERC) Midwest sub region, the fuel avoided due to the savings of central station electricity can be estimated as,

$$AF_{CS} = (ACSE \times AFHR) / 10^6 = 116 \times 10^9 \text{ kJ/yr} \quad (16)$$

Where, AF_{CS} and $AFHR$ are the Avoided Fuel Central Station and Average Fossil Heat Rate. The thermal energy recovered from the DFC1500TM will be used within the facility itself as in section 3.2. Hence,

$$AF_{TH} = 7.4 \times 10^{12} \text{ kJ/yr} \quad (17)$$

Where, AF_{TH} is Avoided Fuel Thermal.

Table 8. Fuel used for transporting feedstock

Feedstock	frequency	Transport			
		type	location from campus facility (km)	km per year ^a	motor gasoline per year ^b (m ³)
MSW collection	daily	semi-trailer	169	617×10^2	17.4
Dog and cat food waste	daily	semi-trailer	4.8	3.5×10^3	0.8
Brewery Waste	weekly	pick-up truck	3.2	3.3×10^2	0.03
Grape skin, rice hull and vines	seasonal	semi-trailer	16.1	8×10^2	0.19

a This includes the back and forth journey of the vehicles.
b Fuel kilometers: 3.5 km/L for a semi-trailer on a flat road and 9 km/L for a pick-up truck.

5.4. CHHP HYDROGEN OUTPUT AND AVOIDED FUEL EMISSIONS

As mentioned in section 4.3, a total of 123 kg of hydrogen will be used per day to displace the conventional fuel. Figure 6 provides the details of this consumption. The fuel displaced by this hydrogen, the energy services provided by the hydrogen, and amount of fuel displaced is identified and tabulated in Table 9 [36]. All the calculations take into consideration the estimated hours of operation of the equipment.

For the application that involves a savings in the electricity, the fuel avoided at the central station is estimated, for others, the conventional fuel avoided for each application, due to the hydrogen used, can be calculated by following equation:

$$AF_H = CHHP_{HC} \times HCR \times HCOCF / DCFCR \quad (18)$$

Where, AF_H , $CHHP_{HC}$, HCR , $HCOCF$ and $DCFCR$ are the Avoided Fuel Hydrogen, CHHP Hydrogen Consumption, Hydrogen Consumption Rate, Heat Content of Conventional Fuel and Displaced Conventional Fuel Consumption Rate respectively.

Therefore, the avoided fuel due to hydrogen usage,

$$AF_H = 1.72 \times 10^{12} \text{ kJ/yr} \quad (19)$$

By using equation (10) the total energy savings is 1.71×10^{12} kJ/yr, and by substituting in equation (11) the input fuel energy content for this architecture can be calculated as 8.8×10^6 kJ/h.

The environmental impact of the proposed design is investigated through the reduction of the carbon dioxide emissions, which can be estimated by the following relationship:

$$OR_{CO_2} = (\sum k) \times (AF_H) \times (ER_{netCO_2}) \quad (20)$$

Where, OR_{CO_2} and ER_{netCO_2} are the Overall CO_2 Reduction and Net CO_2 Emissions Rate. Also, $k = -1$ for fuel consumed and 1 for fuel avoided, which includes the CHHP fuel consumption, fuel consumption for feed stock transport, avoided central station fuel, avoided thermal fuel, and avoided fuel due to hydrogen. Thus, overall CO_2 reduction, be 88,426 tons/yr.

Table 9. Avoided conventional fuel details

Application	Fuel displaced	Energy services provided by utilizing hydrogen (per year)	Amount of conventional fuel avoided (TJ/yr)
Fuel cell forklifts	diesel	630 MWh	73.6
Backup power UPS	diesel	210 MWh	588
H ₂ blended diesel generator	diesel	-	563
Handheld fuel cell charger	central station electricity	331 MWh	3.80
Portable power	central station electricity		
APU for AC unit in electric bus	diesel	548 MWh	94.0
Fuel cell three-wheeler	gasoline	7343 km	270
Fuel cell scooter	gasoline	29,371 km	85.5
Retrofitted electric bike	none	5.50 MWh	0.00
Retrofitted Segway	central station electricity	408 MWh	4.70
Fuel cell utility vehicle	gasoline	841 MWh	25.0
Fuel cell lawn mower	gasoline	383 MWh	12.0

Additionally, to the lessening in the CO₂ emissions, the land required to store the organic wastes if not used otherwise, will be an added advantage. This can be estimated

through the amount of solid waste digested. As mentioned in the technical design section, the digester will have a 50% solid reduction, alleviating 5,475 tons/yr of solid waste disposal.

6. CONCLUSION

In this paper, we have discussed the design of a CHHP system for the Missouri University of Science and Technology campus using local resources. An energy flow and resource availability study is performed to identify the type and source of feedstock required to continuously run the fuel cell system at peak capacity. Following the resource assessment study, the team selects FuelCell Energy DFC1500TM unit for its fuel cell. The CHHP system provides electricity to power the university campus, thermal energy for heating the anaerobic digester, and hydrogen for transportation, back-up power and other needs. The CHHP system will be able to provide approximately 22,000 kWh and 650 kg of hydrogen to the university campus per day. In conclusion, the CHHP system will reduce energy consumption, fossil fuel usage, and greenhouse gas (GHG) emissions at the Missouri S&T campus. It will be able to provide approximately 27% of the university campus' electricity need.

ACKNOWLEDGMENTS

The authors wish to acknowledge the Hydrogen Education Foundation for their support of the annual Hydrogen Student Design Contest which challenges university students to design hydrogen energy applications for real-world use.

REFERNCES

- [1] Hamad TA, Agll AA, Hamad YM, Bapat S, Thomas M, Martin KB, et al, "Hydrogen recovery, cleaning, compression, storage, dispensing, distribution system and End-Uses on the university campus from combined heat, hydrogen and power system," *Journal of Int J Hydrogen Energy*, Vol. 39, Pp. 647-653, (2014).
- [2] Hamad TA, Agll AA, Hamad YM, Bapat S, Thomas M, Martin KB, et al, "Study of a molten carbonate fuel cell combined heat, hydrogen and power system: End-use application," *Journal of Case Studies in Thermal Engineering*, Vol. 1, Pp. 45-50, (2013).
- [3] Hamad TA, Agll AA, Hamad YM, Bapat S, Thomas M, Martin KB, et al, "Hydrogen production and End-Uses from combined heat, hydrogen and power system by using local resources," *Journal of Renewable Energy*, Vol. 71, Pp. 381-386, (2014).
- [4] Hamad TA, Agll AA, Hamad YM, Bapat S, Thomas M, Martin KB, et al, "Study of combined heat, hydrogen and power system based on a molten carbonate fuel cell fed by biogas produced by anaerobic digestion," *Journal of Energy Conversion and Management*, Vol. 81, Pp. 184-191, (2014).
- [5] Yu M , Muy S, Quader F, Bonifacio A, Varghese R , Clerigo E, et al, "Combined Hydrogen, Heat and Power (CHHP) pilot plant design," *Journal of Int J Hydrogen Energy*, Vol. 38, No.12, Pp. 4881-4888, (2013).
- [6] Vera D, Jurado F, de Mena B, Schories G, "Comparison between externally fired gas turbine and gasifier-gas turbine system for the olive oil industry," *Journal of Energy*, Vol. 36, No. 12, Pp. 6720-6730, (2011).
- [7] Bouckaert S, Assoumou E, Selosse S, Maïzi N, "A prospective analysis of waste heat management at power plants and water conservation issues using a global TIMES model," *Journal of Energy*, Vol. 68, Pp. 80-91, (2014).
- [8] Pronto JL, Gooch CA, "Greenhouse gas emission reductions for seven on-farm dairy manure-based anaerobic digestion systems - Final results," *Journal of ASABE*, Vol. 7, Pp. 35-42, (2010).
- [9] Cantrell KB, Ducey T, Ro, KS, "Livestock waste-to-bioenergy generation opportunities," *Journal of Bioresource Technol*, Vol. 99, Pp. 7941-7953, (2008).
- [10] Ghaderi A, Parsa Moghaddam M, Sheikh-El-Eslami MK, "Energy efficiency resource modeling in generation expansion planning," *Journal of Energy*, Vol. 68, Pp. 529-537, (2014).

- [11] Hamad YM, Hamad TA, Agll AA, Bapat S, Thomas M, Martin KB, et al, "Molten Carbonate Fuel Cell Combined Heat, Hydrogen and Power System: Feedstock Analysis," *Journal of Energy Science and Technology*, Vol. 6, No. 2 Pp. 1-5, (2013).
- [12] Weiland P. "Biogas production: Current state and perspectives," *Journal of Appl Microbiol Biot*, Vol. 85, No. 4, Pp. 849-860, (2010).
- [13] Loeser M, Redfern M, "Modelling and simulation of a novel micro-scale combined feedstock biomass generation plant for grid-independent power supply," *Journal of Int J Energ Res*, Vol. 34, No. 4, Pp. 303-320, (2010).
- [14] Ward, A. J., Hobbs, P. J., Holliman, P. J., & Jones, D. L, "Optimisation of the anaerobic digestion of agricultural resources," *Journal of Bioresource Technol*, Vol. 99, No. 17, Pp. 7928-7940, (2008).
- [15] Huang W, Zhang Y, "Energy efficiency analysis: Biomass-to-wheel efficiency related with biofuels production, fuel distribution, and powertrain systems," *Journal of PLoS ONE*, Vol. 6, No. 7, Pp. 7, (2011).
- [16] Rivarolo M, Bogarin J, Magistri L, Massardo, A, "Time-dependent optimization of a large size hydrogen generation plant using "spilled" water at itaipu 14 GW hydraulic plant," *Journal of Int J Hydrog Energ*, Vol. 37, No. 6, Pp. 4434-5443, (2012).
- [17] Zhi X, Yang H, Berthold S, Doetsch C, Shen, J, "Potential improvement to a citric wastewater treatment plant using bio-hydrogen and a hybrid energy system," *Journal of J Power Sources*, Vol. 195, No. 19, Pp. 6945-6953, (2010).
- [18] Sarkar S, Kumar A, "Techno-economic assessment of biohydrogen production from forest biomass in western Canada," *Journal of T ASABE*, Vol. 52, No. 2, Pp. 519-530, (2009).
- [19] Iacovidou E, Ohandja D, Gronow J, Voulvoulis N, "The household use of food waste disposal units as a waste management option: A review," *Journal of Crit Rev Env Sci tec*, Vol. 42, No. 14, Pp. 1485-1508,
- [20] Rao P, Baral S, "Attribute based specification, comparison and selection of feed stock for anaerobic digestion using MADM approach," *Journal of J Hazard Mater*, Vol. 186, No. 2-3, Pp. 2009-2016, (2009).
- [21] Karellas S, Boukis I, Kontopoulos G, "Development of an investment decision tool for biogas production from agricultural waste," *Journal of Renew Sust Energ Rev*, Vol. 14, No. 4, Pp. 1273-1282, (2010).

- [22] Zingoni A, "Shell forms for egg-shaped concrete sludge digesters: A comparative study on structural efficiency," *Journal of Struct Eng Mech*, Vol. 19, No. 3, Pp. 321-336, (2010).
- [23] Banks CJ, Salter AM, Heaven S, Riley K, "Energetic and environmental benefits of co-digestion of food waste and cattle slurry: A preliminary assessment," *Journal of Resour Conserv Recy*, Vol. 56, No. 1, Pp. 71-79, (2011).
- [24] Esposito G, Frunzo L, Panico A, Pirozzi F, "Model calibration and validation for OFMSW and sewage sludge co-digestion reactors," *Journal of Waste Manage*, Vol. 31, No. 21, Pp. 2527-2535, (2011).
- [25] Krishna R, "Adsorptive separation of CO₂/CH₄/CO gas mixtures at high pressures," *Journal of Micropor Mesopor Mat*, Vol. 156, Pp. 217-223, (2012).
- [26] Rehl T, Müller J, "Life cycle assessment of biogas digestate processing technologies," *Journal of Resour Conserv Recy*, Vol. 56, No. 1, Pp. 92-104, (2011).
- [27] Rittmann BE, Mayer B, Westerhoff P, Edwards M, "Capturing the lost phosphorus," *Journal of Chemosphere*, Vol. 84, No. 6, Pp. 846-853, (2011).
- [28] Locher C, Meyer C, Steinmetz H, "Operating experiences with a molten carbonate fuel cell at stuttgart-möhringen wastewater treatment plant," *Journal of Water Sci Technol*, Vol. 65, No. 5, Pp. 789-794, (2012).
- [29] Rasi S, Läntelä J, Veijanen A, Rintala J, "Landfill gas upgrading with countercurrent water wash," *Journal of Waste Manage*, Vol. 28, No. 9, Pp. 1528-1534, (2012).
- [30] Anozie AN, Layokun SK, Okeke CU, "An evaluation of a batch pilot-scale digester for gas production from agricultural wastes," *Journal of Energy Source*, Vol. 27, No. 14, Pp. 1301-1311, (2005).
- [31] Guha D, "Anchored enzymes in biogas generation," *Journal of the ACS National Meeting Book of Abstracts*, Vol. 238, Pp. 979-984, (2009).
- [32] Köppel, W, "Biogas treatment for SNG production," *Journal of Int Gas Res Conf Proceedings*, Vol. 2, Pp. 1327-1345, (2008).
- [33] Rapport JL, Zhang R, Jenkins BM, Hartsough BR, Tomich TP, "Modeling the performance of the anaerobic phased solids digester system for biogas energy production," *Journal of Biomass Bioenerg*, Vol. 35, No. 3, Pp. 1263-1272, (2011).

- [34] Kamarudin SK, Daud WRW, Som AM, Mohammad AW, Takriff S, Masdar MS. "The conceptual design of a PEMFC system via simulation," *Journal of Chem Eng J*, Vol. 103, No. 1-3, Pp. 99-113, (2004).
- [35] <http://hydrogencontest.org/pdf/Webcast%2011-4-2011%20FCE.pdf>. "FuelCell Energy presentation webcast,"
- [36] <http://hydrogencontest.org/pdf/AOG%20Composition%20Example.pdf.2012> "Anode Outlet Gas Composition Calculation Example,"
- [37] Kinoshita CM, Turn SQ, Overend RP, Bain RL, "Power generation potential of biomass gasification systems," *Journal of J Energy Eng*, Vol. 123, No. 3, Pp. 88-113, (1997).
- [38] Abdel Dayem, A M, "Experimental and numerical performance of a multi-effect condensation-evaporation solar water distillation system," *Journal of Energy*, Vol. 31, No. 14, Pp. 2374-2391, (2006).
- [39] Agll AA, Hamad YM, Hamad TA, Bapat S, Thomas M, Martin KB, et al, "Study of a molten carbonate fuel cell combined heat, hydrogen and power system: Energy analysis," *Journal of App Thermal Eng*, Vol. 59, Pp. 634-638, (2013).
- [40] http://www.hydrogencontest.org/pdf/2012%20HSDC_Environ_Guidelines.pdf. "2012 Hydrogen Student Design Contest Energy Savings and Environmental Analysis Guidelines,"

II STUDY OF COMBINED HEAT, HYDROGEN AND POWER SYSTEM BASED ON A MOLTEN CARBONATE FUEL CELL FED BY BIOGAS PRODUCED BY ANAEROBIC DIGESTION

Tarek A. Hamad, John W. Sheffield

Department of Mechanical and Aerospace Engineering, Missouri University of Science
and Technology, 400 W 13th Street, Rolla, MO 65409-0050, USA

Received 17 August 2013

Accepted 16 February 2014

ABSTRACT

To address the problem of fossil fuel usage and high greenhouse gas emissions at the Missouri University of Science and Technology campus, using of alternative fuels and renewable energy sources can lower energy consumption and greenhouse gas emissions. Biogas, produced by anaerobic digestion of wastewater, organic waste, agricultural waste, industrial waste, and animal by-products is a potential source of renewable energy. In this work, we have discussed the design of CHHP system for the campus using local resources. An energy flow and resource availability study is performed to identify the type and source of feedstock required to continuously run the fuel cell system at peak capacity. Following the resource assessment study, the team selects FuelCell Energy DFC1500TM unit as a MCFC. The CHHP system provides electricity to power the university campus, thermal energy for heating the anaerobic digester, and hydrogen for transportation, back-up power and other needs. In conclusion, the CHHP system will be able to reduce fossil fuel usage, and greenhouse gas emissions at the university campus.

Keywords: Tri-generation, Hydrogen from renewable energy, production and use, Anaerobic digestion, Renewable energy, Combined Heat, Hydrogen and Power

1. INTRODUCTION

The Missouri University of Science and Technology (Missouri S&T) campus in Rolla, Missouri, USA is a relatively small campus with 1.15 km² and approximately 6,500 students on campus. The university is one of the City of Rolla's largest electric power consumers with a peak demand of 6.36 MW_e and annual electric energy consumption of 2.55×10^6 kWh/yr. Currently, electrical power for the university campus is purchased from RMU and distributed from the substation and switchgear located at the campus power plant. In addition, the university thermal power plant generates electricity with a back pressure steam turbine, accounting for an additional 10% of electricity. The power plant, built in 1945, is fueled by coal and wood chips and provides steam to the university campus for space heating, chilled water via absorption chillers and back pressure steam turbines. Biogas produced by anaerobic digestion of wastewater, organic waste, agricultural waste, and industrial waste is a potential source of renewable energy. Treated biogas can be used to generate CHHP using a molten carbonate fuel cell. The paper investigates the use of a CHHP system at (Missouri S&T) campus. The power generated by the CHHP system is used at various locations on the campus to reduce the total electric power purchased and minimize air pollution to benefit overall community health [1–3]. In addition, the CHHP system has higher efficiency than other distributed generation plants of similar size [4, 5]. The hydrogen generated is used to power different applications on the university campus including personal transportation, backup power, portable power, and mobility/utility applications. Locally available feedstocks near the Missouri S&T campus that can be used for biogas production were identified [6–8]. An energy flow and resource availability study was performed to identify the type and source of feedstock required to continuously run the CHHP system to produce maximum capacity of electricity, heat recovery and hydrogen [9].

2. RESOURCE ASSESSMENT

2.1. FEEDSTOCK SOURCE IDENTIFICATION

During the assessment, “locally available feedstock” was defined as one which is within 20 km of Rolla. The largest source of locally available feedstock is MSW averaging 60 tons/day. Of this, approximately 33% is organic waste including 17% food waste. The campus plans to partner with the City of Rolla and will start an “Organic Waste Collection Program” to collect organic waste. Currently, the city offers residential curbside collection of recyclable materials at no extra cost. The second largest local resource is the rejects and waste resulting from change over at the Royal Canin dog and cat nutrition company. Their waste is currently disposed at a landfill facility 40 km from the company.

Potential feedstock from the campus includes food waste and sanitary sewer. Food waste collected daily is mixed with the trash and the sanitary sewer and is connected to the city’s main sewer lines. A Pugh chart is created to compare different feedstock and is shown in Table 1 [10].

Table 1. Pugh Chart for feedstock

Key Criteria	Weight	MSW	Dog food waste	Food waste	Wood chips	Grape skin	Vines	Brewery waste	Waste water
Availability	4	4	4	3	4	2	2	4	4
Ease of collection	3	3	4	4	4	4	3	4	4
Ease of digestion	4	3	4	4	1	4	2	4	3
Energy value	3	3	4	4	2	4	2	4	2
Total		46	56	52	38	48	31	56	46

Methods for feedstock collection, transportation, and storage were also identified and are tabulated in Table 2 Feedstock, except waste water, will be stored on campus at the feedstock storage facility (Facility A) and will undergo anaerobic digestion at this location. Collection and anaerobic digestion of waste water will be off-campus at the treatment plant (Facility B) [10, 11].

Table 2. Feedstock availability, collection, transportation and storage

Type of feedstock	Source	Collection		Transportation	Storage
		Frequency	Collection point		
Dog and cat food waste	Royal Canin	daily	warehouse	semi-trailer	Facility A
Food waste	University courts	daily	food court	pickup truck	Facility A
Wood chips	university power plant	daily	delivered at site	trailer truck	Facility A
Waste water	SE Wastewater Treatment Plant	daily	delivered at site	used at facility	Facility B
MSW	Rolla municipal solid waste	weekdays	organic waste collection program	trash truck	Facility A
Brewery waste	Public House Brewery	weekly	brewery	pickup truck	Facility A
Grape skin, rice hull and vines	St. James Winery	seasonal	winery/vineyard	semi-trailer	Facility A
Timber	MTNF	seasonal	MTNF	trailer truck	Facility A

3. EXPERIMENTAL PROCEDURE

3.1. DFC[®] TECHNOLOGY STATUS AND DFC1500TM FUELCELL POWER PLANT

The DFC[®] technology offers higher net electrical efficiency and a cleaner exhaust stream when operating on biogas from an anaerobic digester than any competing conventional technology such as reciprocating engines or gas turbines. The DFC[®] systems also have a good heat-to-power ratio for support of digester operations. FuelCell Energy offers three DFC[®] products; the DFC 300TM, DFC 1500TM, and DFC 3000TM, which are 300 kW, 1.4 MW, and 2.8 MW, power plants, respectively; the natural gas consumptions are 66 m³/h, 307 m³/h, and 615 m³/h, respectively. The DFC[®] 1500TM matches up well with the needs of a wastewater treatment plant, or a food processing facility where methane produced by anaerobic digestion can be efficiently utilized to produce electricity. FuelCell Energy's DFC1500 system is a self-contained electrical power generation system capable of providing 1.4 MW of high-quality baseload power at or near the point of use. Featuring ultra-low emissions and low operating noise, the DFC1500 is suitable for locations where traditional power generation technologies are not feasible or desirable. The DFC1500 is an ideal on-site power generation solution for large installations requiring baseload power and that have an application for high grade heat such as facility heating and/or absorption chilling. The system is suitable for a wide range of applications, including wastewater treatment plants, manufacturing, hospitals and universities. The system has an electrical efficiency of 47%, giving it higher efficiency than other distributed generation plants of similar size, and with virtually no pollutants. When configured for Combined Heat and Power (CHP), total thermal efficiency can approach 90%. Due to its modular design, the DFC1500 is easily installed in comparison to other power generation technologies. Quiet operation and modest space requirements enable siting the power plants next to buildings. The clean air permitting process is facilitated by the low emissions and near-zero pollutant profile of the DFC power plants. Consequently, a DFC1500TM unit was selected for the CHHP system for which local resources can provide 90% of the fuel requirements. The daily unmet fuel need will be supplied by natural gas purchased from the local utility company. In order to accommodate the fluctuations in gas quality, the natural gas used in the design is

assumed to contain 98% methane and 2% carbon dioxide (with an average heating value of 37 MJ/m³).

3.2. CHHP SYSTEM TECHNICAL DESIGN

The design discussed in this paper has three major systems: (i) anaerobic digestion system, (ii) CHHP system consisting of a DFC1500TM fuel cell unit, and (iii) hydrogen compression, storage, and dispensing system [1, 2]. These systems were designed based on the results from the feedstock assessment and the expected biogas production from local resources. It was found that the anticipated methane production after biogas treatment is 260 m³/h with a heat content of 37 MJ/m³.

3.2.1. Site Plan and Location. The selected the location has been set aside for the existing ‘Alternative Fuels Station’ and future ‘Green Hotel and Convention Center’ in the Campus Master Plan developed in 2009 to install the system. By doing so, the design is compliant with the University’s Master Plan and maximized the chances for implementation. Currently, Missouri S&T has a 350 bar hydrogen fueling station, an electric vehicle charging station, a hydrogen research and development garage, and a renewable energy transit depot in the alternative fuels station area. The proposed site location and the various components are shown in Fig.1.

Table 2 is created to easily identify the different systems that are included in the design and to facilitate understanding of the whole system operation. An additional facility (Central Control Station), consisting of a 12.2 m × 7.6 m (92.7 m²) building is also included in the design to control and monitor the operations of different systems.

3.3. ANAEROBIC DIGESTION SYSTEM

The anaerobic digestion system and the CHHP system are sized based on the amount of locally available feedstock and the amount of methane gas generated respectively [1, 2, 10]. The hydrogen recovery, purification, compression, storage, and distribution system are designed based on the hydrogen demand on the university campus and the 65% fuel utilization rate [12–15].

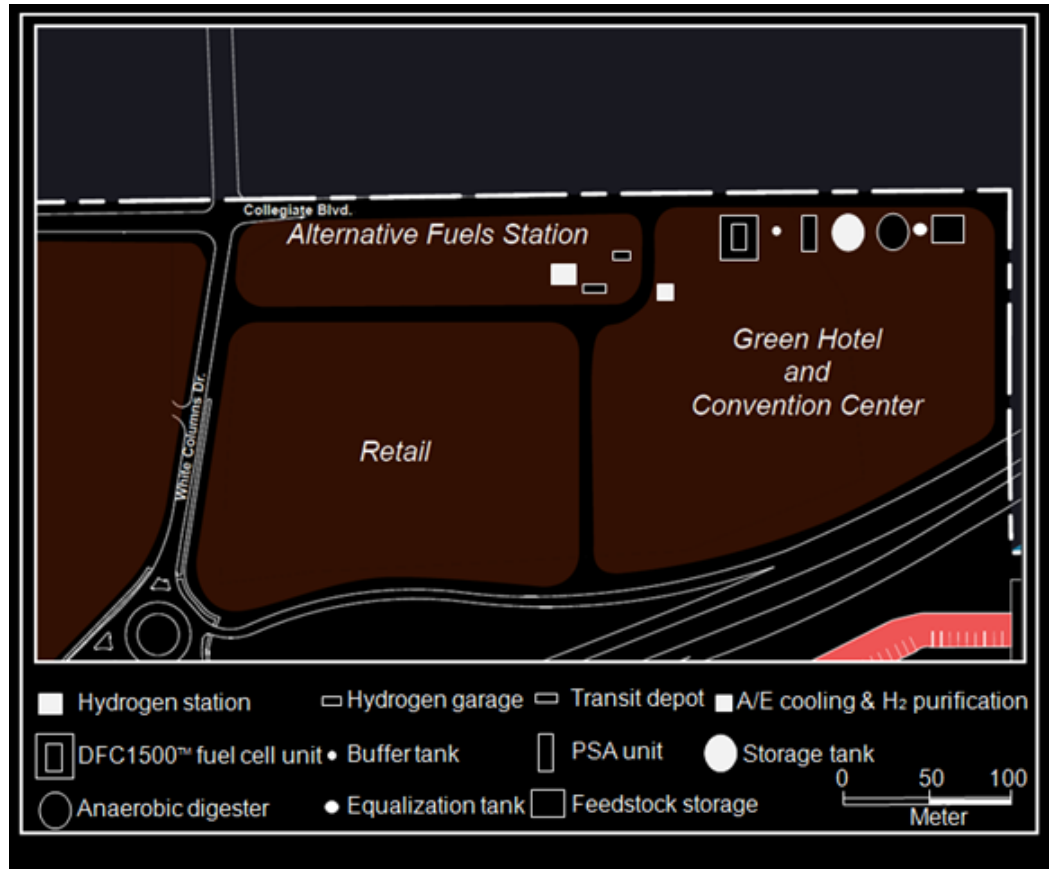

Figure 1. Site plan with anaerobic digester, CHHP system and hydrogen fuelling station

The feedstock is collected and transported to the storage facility as described in the resource assessment section. The storage facility consists of a 30.5 m × 30.5 m (930 m²) steel building to protect the feedstock from the elements. It houses a macerator to chop feedstock larger in diameter than 0.05 m to aid in the methane production rate in the digester. Since the waste from the Royal Canin dog and cat food plant and the winery is relative small in size, only MSW and food waste from the university will be fed into the macerator (17,240 kg/day). The design employs a 15 kWe Taskmaster[®] 1600 shredder from Franklin Miller Inc. to reduce the size of the feedstock. The processed feedstock together with the waste from the dog and cat food plant and winery will be stored in a cement storage bin in the storage facility [16, 17].

Digester and biogas production are shown in Fig. 2 [10]. The feedstock from the cement storage bin is transported via a screw feeder to a hygienisation unit where it is

heated to 70 °C for one hour to remove all the pathogens [18, 19]. After heating, the feedstock is transported to a 45.4 m³ equalization tank where the biomass is mixed to form a homogenous mixture before being fed into the digester. The digester used in the design is a complete-mix anaerobic digester from Siemens and is a concrete tank with a diameter of 30.5 m and a tank side water depth of 12.8 m. The tank wall height below grade is 14.6 m and has a floor slope of 1:6. The outer wall is insulated and the inner wall of the tank is lined with stainless steel hot water pipes to maintain an optimum temperature of 40 °C. The design uses a highly efficient JetMix™ Vortex Mixing System by Siemens, to mix the biomass inside the digester. The system suspends organic and inorganic solids with intermittent mixing, making possible power savings of up to 50% or more. The system maintains efficiency regardless of tank level and minimizes dead spots due to its innovative mixing pattern and also has the capability to mix multiple tanks using one central pumping facility. This system will eliminate the use of multiple pumps and will reduce the capital cost of the digester system. The proposed anaerobic digester is sized such that it has a detention time of 20 days. The specification and details of the digester are tank volume 892 m³, tank wall thickness 0.30 m, quantity of solids to digester 27×10³ kg/day, volatile solids concentration 80%, anticipated solids reduction 50%, anticipated gas yield 0.93 m³/kg VS destroyed, anticipated biogas production 425 m³/h, and anticipated natural gas equivalent 260 m³/h [10].

Inside the anaerobic digester, microorganisms act on the organic feedstock to produce biogas, digestate, and water. The anticipated biogas production from the digester is 425 m³/h or 260 m³/h of natural gas equivalent. The digestate from the anaerobic digester is pumped to the storage tank and is stored there until it is ready to be collected and transported to the facility A. The storage tank is also an insulated concrete tank and can also be used to store biogas if the buffer tank holding the biogas is full.

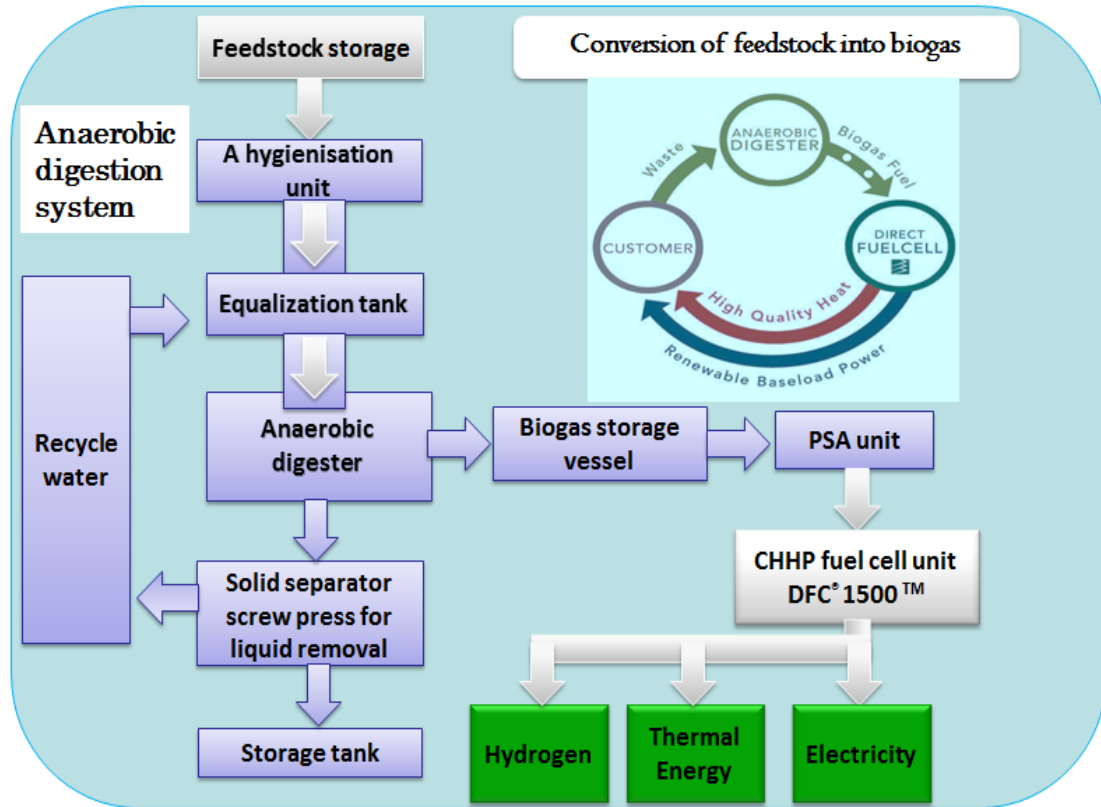

Figure 2. Flow diagram for digester and biogas production

3.4. GAS TREATMENT SYSTEM AND FUEL STORAGE

Biogas from the anaerobic digestion is stored in a buffer tank which supplies biogas to the gas treatment system. The treatment system uses Pressure Swing Adsorption (PSA) technology to separate methane present in the biogas [23, 24]. The design has a total of four adsorbers to ensure a continuous stream of high quality methane. While carbon dioxide (CO_2), hydrogen sulfide (H_2S) and other impurities in one set of tanks are desorbing, biogas will be fed to the second set of tanks for adsorption. The product from this gas treatment system is pipeline quality natural gas which is fed into the fuel cell [25]. The design included the PSA unit for the following reasons [9]:

- i. The DFC® fuel cell units cannot accept H_2S , water (H_2O), and other impurities in its input fuel [26].

- ii. Inlet fuel pressure to the fuel cell should be between 2 – 2.4 bar. If the fuel contains 40% carbon dioxide, it will impact the sizing of the equipment downstream the fuel cell. In other words, the design will require a higher capacity heat exchanger, water gas shift reactor, and hydrogen purification or separation system. For example, DFC1500TM requires 307 m³/h of natural gas at 37 MJ/m³. If using biogas (60% methane and 40% carbon dioxide), the fuel cell system will require 477 m³/h of biogas as fuel to operate. This will increase the size of the equipment downstream the fuel cell by 55% and will increase its capital cost which is not desirable [1, 2, 10, 27 –29].
- iii. The biogas output from the digester can vary due to disruption in the feedstock availability or any other unforeseeable reasons. In this case, the system will have to use natural gas purchased from utility company to provide any unmet fuel demand by the fuel cell [30, 31]. It was estimated that the systems downstream the fuel cell will run at 78.5% of their normal capacity if the fuel quality changes from 100% biogas to 50% biogas and 50% natural gas.
- iv. The product gas from the PSA unit is expected to have an average heat content of 37 MJ/m³ which is roughly equal to the average heat content of natural gas consumed in Missouri (38 MJ/m³) through 2007–2010 [32]. The process and flow during the biogas treatment is depicted in Fig. 3.

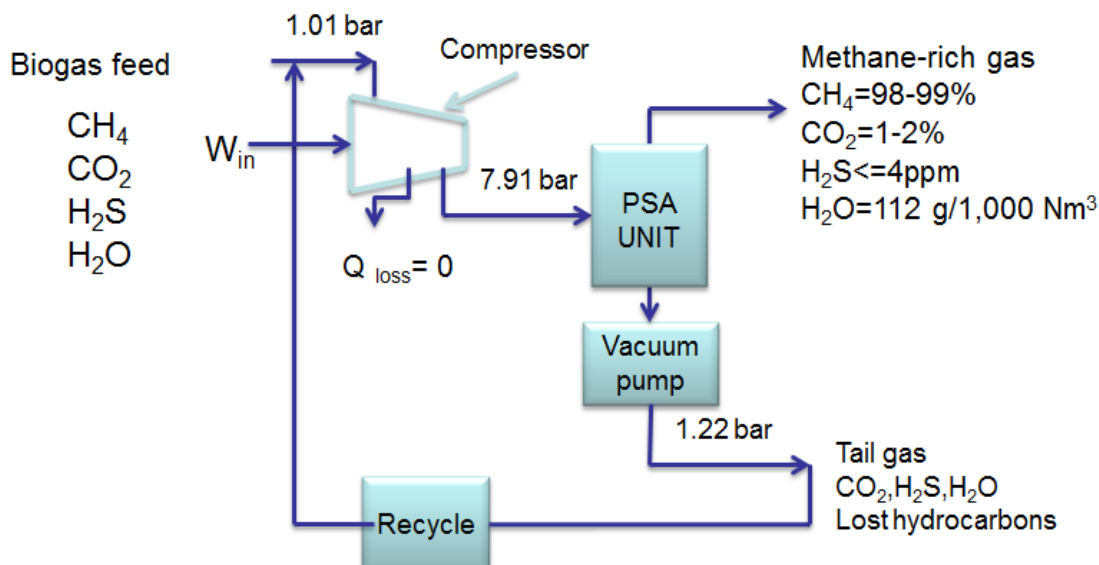

Figure 3. Flow balance diagram

3.5. ANODE OUTLET GAS (AOG) CALCULATIONS

As the mention in section 3.1., the natural gas used in the design is assumed to contain 98% methane and 2% carbon dioxide (with an average heating value of 37 MJ/m^3). The anode outlet gas calculations are made based on the AOG composition calculation document provided by FuelCell Energy [33]. It is assumed that all methane entering the DFC[®] unit is internally reformed and converted to hydrogen and that only 65% (the fuel utilization rate) of the H_2 produced is reacted at the anode to produce electricity. In order to reflect the AOG composition, it is assumed that one third of the 35% hydrogen produced is back-shifted to produce H_2O and CO . Based on these assumptions and the processes taking place inside the fuel cell (fig. 4), the following equations (1 – 5) for every one mole of methane (CH_4) entering the anode side are obtained.

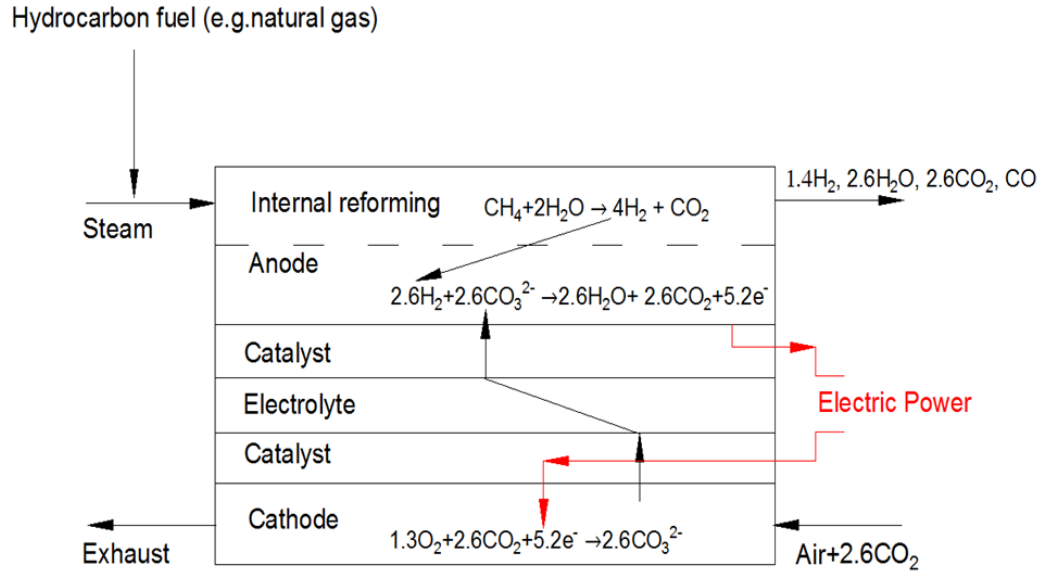

Figure 4. Internal reforming DFC[®] technology

Internal reforming:



Assuming one mole of CH_4 is fed to the DFC[®] system; four moles of hydrogen will be produced. But, only 65% of the hydrogen (i.e. 2.6 moles) reacts at the anode and will result in the following equation.

Corresponding reaction at anode:

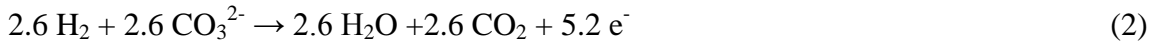

The remaining 35% of the H_2 (1.4 moles) and the entire CO_2 (1 mole) from equation (1) goes directly to the AOG. Combining the products from (2) and 1.4 moles of H_2 and 1 mole of CO_2 from (1) results in the following AOG composition.



But in reality, another internal reaction takes place in the DFC[®] fuel cell. One third of the H_2 in equation (3) (i.e. 0.47 moles) needs to be back-shifted to H_2O and CO resulting in equation (4).



Combining equations (3) and (4) yields the following products:

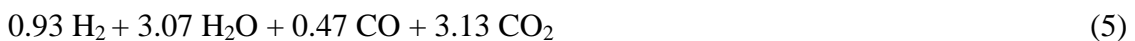

Hence for every one mole of CH₄ the following AOG composition is obtained as shown in Table 3.

Table 3. Anode outlet gas composition

On a molar percentage basis – NG*	
H ₂ O	40.4%
CO ₂	41.2%
CO	6.2%
H ₂	12.2%
H ₂ O	40.4%
*Assuming 100% CH ₄	

The inlet fuel requirement of the DFC1500TM unit based on 37 MJ/m³ input fuel is calculated and found to be 286 m³/h. Assuming that the input fuel consists of 98% CH₄ and 2% CO₂, 286 m³/h of fuel consists of 198 moles of CH₄ and 4 moles of CO₂. The actual AOG flowrate corresponding to 198 moles of methane per minute is calculated using equation (5) shown in Table 4.

Table 4. Anode outlet gas flowrate of the DFC1500TM unit

Gas	mol/min	molar mass	g/min	L/s	density NTP (kg/m ³)
H ₂	156.5	2	315.6	63	0.089
H ₂ O	516.8	18	9,309.6	207.9	0.804
CO	79.10	28	2,216	34.1	1.165
CO ₂	526.90	44	23,187	226	1.842

3.6. HYDROGEN RECOVERY AND CLEANING SYSTEM

In order to achieve a CHHP system, hydrogen from the AOG must be recovered, cleaned and distributed from the DFC[®] fuel cell system. This section explains the

hydrogen recovery and water-gas shift reaction for additional hydrogen production, removal and recycling of water, purification of hydrogen gas, and CO₂ transfer to the cathode side of the fuel cell. The details of the hydrogen recovery and purification process are shown in Fig. 5.

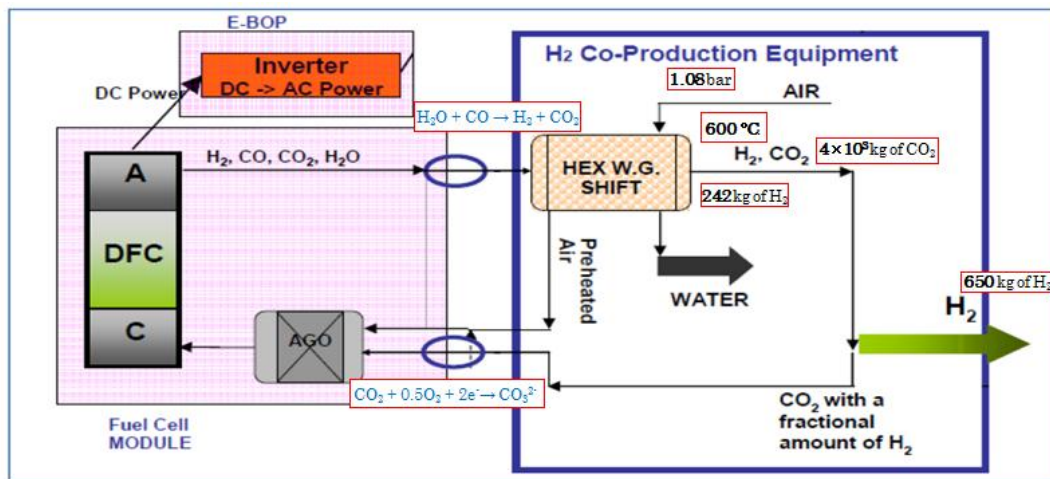

Figure 5. Hydrogen recovery and purification

The AOG outlet pressure is 1.08 bar and outlet temperature to be 600 °C. The AOG is first cooled and pressurized to undergo water-gas shift.



The entire CO present in the AOG reacts with H₂O to produce an additional 242 kg of H₂ and of 4×10³ kg of CO₂ per day. The water vapor is condensed and recycled to the anode side of the fuel cell for the internal reforming of methane. The amount of water produced during condensation is greater than the fuel cell requirement with the excess water is sent into the sewer. The CO₂ and H₂ coming out of the water-gas shift reactor is cooled and separated using a PSA unit. The hydrogen coming out of the PSA unit is compressed and used for different applications on the university campus. Outside air is preheated using the heat exchanger and is mixed with the CO₂ coming out the PSA unit in AGO. The mixture is then transferred to the cathode to complete the cathode reaction as shown in equation (7).

Reaction at cathode:



The flow rates of gases at different stages were tabulated in Table 5. These flow rates are necessary to calculate the amount of hydrogen generated, amount of outside air needed, and amount of exhaust gas. The following assumptions were made during the calculations: (i) H₂ recovery rate from PSA unit is 90%; (ii) N₂ is inert and does not take part in the cathode reactions; (iii) amount of outside air was calculated based on the amount of CO₂ present on the PSA tail gas; (vi) only 70% of CO₂ undergoes reaction to maintain the CO₃²⁻ equilibrium inside the fuel cell. Based on the hydrogen flow rate from the PSA product outlet, the amount of hydrogen generated per day is approximately 650 kg.

Table 5. Flow of gases at different sections of the system

Gas	HEX W.G. shift inlet (mol/min)	HEX W.G. shift outlet (mol/min)	PSA product outlet (mol/min)	PSA tail gas (mol/min)	AGO inlet (mol/min)	cathode exhaust (mol/min)
H ₂	156.5	235.6	212	23.6	23.6	23.6
CO ₂	526.9	606	-	606	606	181.8
H ₂ O	516.8	437.7	-	-	-	-
CO	79.1	-	-	-	-	-
O ₂	-	-	-	-	303	90.9
N ₂	-	-	-	-	1,140	1,140

3.7. HEAT RECOVERY AND ELECTRIC POWER USAGE

The heat energy available for recovery from the DFC1500TM unit working in the CHHP mode is relatively lower than the DFC1500TM unit working in the CHP mode. This is due to the losses associated with the hydrogen recovery. Heat is recovered from the fuel cell exhaust gas using an air to water heat exchanger and will be transported to

various locations as hot water. The electric power generated by the fuel cells will be the primarily power source for the future Green Hotel and will also be distributed to the university campus [1, 34].

3.8. HYDROGEN COMPRESSION, STORAGE, DISPENSING/ DISTRIBUTION SYSTEM

The system will be incorporated into the existing hydrogen infrastructure on the university campus. The existing hydrogen station was designed such that it could handle higher volume of hydrogen in the future. The product hydrogen from the PSA unit will be transferred into the buffer tank located in the adjacent hydrogen station via pipeline. The buffer tank feeds two compressors; (i) the existing Hydro-Pac C06-10-70/140LX compressor (415 bar) and (ii) the PDC machines (PDC-13-1000-3000) compressor (250 bar). The compressed hydrogen from the Hydro-Pac compressor will be stored in existing storage tanks. Hydrogen from the PDC machine compressor will be used to fill a hydrogen tube trailer and K-cylinder manifold [1, 2].

4. RESULTS AND DISCUSSION

4.1. ENERGY END-USES ON THE UNIVERSITY CAMPUS FROM CHHP SYSTEM

Different uses for the electric, thermal and hydrogen energy from the DFC1500TM fuel cell were identified. A 65% fuel utilization rate for electricity production and 35% for hydrogen production was used while making the calculations for electric, thermal, and hydrogen output from the CHHP system.

4.2. ELECTRICITY USE

The electric power output of the DFC1500TM unit operating in the simple cycle CHP mode is 1.4 MW_e. This corresponds to the net power after providing the parasitic loads for its MBOP and energy loss in the E-BOP. However, there are additional components that require electric power for the DFC1500TM unit operating in CHHP mode. These components include the heat exchanger for anode outlet gas cooling, the water-gas shift reactor, and the PSA unit for hydrogen purification and operate collectively with the fuel cell unit to form the CHHP system. Based on the power requirements of these components, the net power output from the CHHP system was estimated to be 1.1 MW_e. The total electric power requirement of different equipment used in the design is tabulated in Table 6[1, 2, 11].

Table 6. Power demand and energy consumption

Equipment	Max. power rating (kW _e)	Daily operation time (h)	Daily energy consumption (kWh)
Feedstock storage facility	5	12	60
Macerator	15	4	60
Screw feeder	5	4	20
Pump	75	4	300
Hygienization unit	2	4	8
Anaerobic digester	5	24	120
Storage tank	5	24	120
Biogas PSA unit	40	24	960
Hydrogen compressor Comp1	7.5	24	180
Hydrogen compressor Comp2	100	24	2.4×10 ³
Auxiliary loads	20	16	320
Total	279.5	164	4,584

Auxiliary loads include site lighting, safety devices, hydrogen dispenser, and electric loads at central control station. The total net energy production from the CHHP system is 26.4×10^3 kWh per day and the energy demand for on-site use is 4,584 kWh per day. Hence, the CHHP system will be able to provide 22×10^3 kWh per day to the university campus. This corresponds to 27% of the whole campus electricity requirement.

4.3. THE HEAT RECOVERY SYSTEM USE

The DFC1500TM unit has 4 GJ/h at 322 °K available for heat recovery while operating in CHP mode. However, the recoverable heat from a DFC1500TM unit operating in CHHP mode is considerably lower than compared to the operating in CHP mode. This is due to the cooling of anode outlet gas, removal of water vapor, hydrogen

recovery, and lower flow rate of the exhaust gases. The thermal energy available for heat recovery was calculated based on the cathode exhaust gas composition in Table 5 and equation (8) and is shown in Table 7. The temperature difference of the input and output temperature of the heat recovery system is 322° K (644° K -322° K) [1, 2, 11].

$$Q = m \times C_p (\Delta T) \quad (8)$$

Where: m , C_p and ΔT are the mass flow rate of the gas (kg/h), the specific heat of the gas (kJ/kgK) and the change in temperature of the gas (K) respectively.

Table 7. Thermal energy available for heat recovery from the DFC1500TM CHHP system

Gas	Cathode exhaust (kmol/min)	Mass flow rate (kg/h)	Cp (kJ/kgK)	ΔT (K)	Q flow rate (MJ/h)
H ₂	0.024	2.85	14.32	322	13.1
CO ₂	0.18	196.5	0.84	322	53.4
O ₂	0.91	152.79	0.92	322	45.2
N ₂	1.14	2,188.28	1.04	322	732.8
Total		2,540			844.6

4.4. UTILIZATION OF HYDROGEN PRODUCTION

The team identified many end uses for hydrogen use on the university campus including personal transportation applications, backup power applications, portable power applications, and other mobility applications. The total hydrogen usage per day is presented tabulated in Table 8.

The major use of the hydrogen on the university campus is for fueling personal transporters. They include fuel cell scooters, Segways and electric bikes retrofitted with fuel cells. The Segways and electric bikes will be retrofitted in-house at the hydrogen research and development garage. The retrofitted Segways and bikes will have fuel cells that act as range extenders for the on-board batteries and will recharge it when the state of charge falls below a certain set value.

The design also incorporates different hydrogen mobility applications for the university campus.

Table 8. Hydrogen applications and usage on the university campus

Applications	Potential user	# of units	H ₂ usage (kg/day)
Personal transportation			
Fuel cell scooter	faculty, students, staff	5	5
Retrofitted Segway	police, faculty, students, staff	12	6
Retrofitted electric bike	students	45	45
Mobility applications			
Fuel cell forklifts	physical facilities	2	4.8
Fuel cell utility vehicle	landscaping, physical facilities	2	4.8
Fuel cell lawn mower	landscaping	1	2.4
Fuel cell three-wheeler	university police, campus tours	6	4
Backup power			
Fuel cell UPS	physical facilities	3	25
H ₂ blended diesel generator	physical facilities	4	4
Portable power			
Handheld fuel cell charger	faculty, students, staff	150	15
Fuel cell portable power	university police, physical facilities	10	2
Other			
APU for A/C unit in electric bus	university transit	2	4
APU for unmanned aerial vehicle	AAVG ^a team	1	1
Total			123

5. CONCLUSION

In this paper, we have discussed the design of a CHHP system for the Missouri University of Science and Technology campus using local resources. An energy flow and resource availability study is performed to identify the type and source of feedstock required to continuously run the fuel cell system at peak capacity. Following the resource assessment study, the team selects FuelCell Energy DFC1500TM unit for its fuel cell. The CHHP system provides electricity to power the university campus, thermal energy for heating the anaerobic digester, and hydrogen for transportation, back-up power and other needs. The CHHP system will be able to provide approximately 22,000 kWh and 650 kg of hydrogen to the university campus per day. In conclusion, the CHHP system will reduce energy consumption, fossil fuel usage, and greenhouse gas (GHG) emissions at the Missouri S&T campus. It will be able to provide approximately 27% of the university campus' electricity need.

ACKNOWLEDGMENTS

The authors wish to acknowledge the Hydrogen Education Foundation for their support of the annual Hydrogen Student Design Contest which challenges university students to design hydrogen energy applications for real-world use.

APPENDIX A. SUPPLEMENTAL DATA

The full report submission for the Hydrogen Education Foundation's Hydrogen Student Design Contest is available online: <http://hydrogencontest.org/previous.asp>.

REFERNCES

- [1] Hamad TA, Agll AA, Hamad YM, Bapat S, Thomas M, Martin KB, et al, "Hydrogen recovery, cleaning, compression, storage, dispensing, distribution system and End-Uses on the university campus from combined heat, hydrogen and power system," *Journal of Int J Hydrogen Energy*, Vol. 39, Pp. 647-653,(2014).
- [2] Hamad TA, Agll AA, Hamad YM, Bapat S, Thomas M, Martin KB, et al, "Study of a molten carbonate fuel cell combined heat, hydrogen and power system: End-use application," *Journal of Case Studies in Thermal Engineering*, Vol. 1, Pp. 45-50,(2013).
- [3] Yu M , Muy S, Quader F, Bonifacio A, Varghese R , Clerigo E, et al, "Combined Hydrogen, Heat and Power (CHHP) pilot plant design," *Journal of Int J Hydrogen Energy*, Vol. 38, No.12, Pp. 4881-4888,(2013).
- [4] Braun R J, "Techno-economic optimal design of solid oxide fuel cell systems for micro-combined heat and Power applications in the U.S.," *Journal of J Fuel Cell Sci Technol.*, Vol. 7, No. 3, Pp. 0310181-03101815,(2013).
- [5] Vera D, Jurado F, de Mena B, Schories G, "Comparison between externally fired gas turbine and gasifier-gas turbine system for the olive oil industry," *Journal of Energy*, Vol. 36, No. 12, Pp. 6720-6730,(2011).
- [6] Oller I, Malato S, Sánchez-Pérez JA, "Combination of Advanced Oxidation Processes and biological treatments for wastewater decontamination," *Journal of Sci Total Environ.*, Vol. 409, Pp. 4141-4166,(2011).
- [7] Pronto JL, Gooch CA, "Greenhouse gas emission reductions for seven on-farm dairy manure-based anaerobic digestion systems - Final results," *Journal of ASABE*, Vol. 7, Pp. 35-42, (2010).
- [8] Cantrell KB, Ducey T, Ro, KS, "Livestock waste-to-bioenergy generation opportunities," *Journal of Bioresource Technol*, Vol. 99, Pp. 7941-7953, (2008).
- [9] Demirbas A, "Importance of biomass energy sources for Turkey," *Journal of. Energ Policy*, Vol. 36, Pp. 834-842, (2008).
- [10] Hamad YM, Hamad TA, Agll AA, Bapat S, Thomas M, Martin KB, et al, "Molten Carbonate Fuel Cell Combined Heat, Hydrogen and Power System: Feedstock Analysis," *Journal of Energy Science and Technology*, Vol. 6, No. 2 Pp. 1-5, (2013).

- [11] Agll AA, Hamad YM, Hamad TA, Bapat S, Thomas M, Martin KB, et al, "Study of a molten carbonate fuel cell combined heat, hydrogen and power system: Energy analysis," *Journal of App Thermal Eng.*, Vol. 59, Pp. 634-638, (2013).
- [12] Ward, A. J., Hobbs, P. J., Holliman, P. J., & Jones, D. L, "Optimisation of the anaerobic digestion of agricultural resources," *Journal of Bioresource Technol.*, Vol. 99, No. 17, Pp. 7928-7940, (2008).
- [13] Huang W, Zhang Y, "Energy efficiency analysis: Biomass-to-wheel efficiency related with biofuels production, fuel distribution, and powertrain systems," *Journal of PLoS ONE*, Vol. 6, No. 7, Pp. 7, (2011).
- [14] Rivarolo M, Bogarin J, Magistri L, Massardo, A, "Time-dependent optimization of a large size hydrogen generation plant using "spilled" water at itaipu 14 GW hydraulic plant," *Journal of Int J Hydrog Energ*, Vol. 37, No. 6, Pp. 4434-5443, (2012).
- [15] Zhi X, Yang H, Berthold S, Doetsch C, Shen, J, "Potential improvement to a citric wastewater treatment plant using bio-hydrogen and a hybrid energy system," *Journal of J Power Sources*, Vol. 195, No. 19, Pp. 6945-6953, (2010).
- [16] Sarkar S, Kumar A, "Techno-economic assessment of bio hydrogen production from forest biomass in western Canada," *Journal of T ASABE*, Vol. 52, No. 2, Pp. 519-530, (2009).
- [17] Iacovidou E, Ohandja D, Gronow J, Voulvoulis N, "The household use of food waste disposal units as a waste management option: A review," *Journal of Crit Rev Env Sci tec*, Vol. 42, No. 14, Pp. 1485-1508,
- [18] Rao P, Baral S, "Attribute based specification, comparison and selection of feed stock for anaerobic digestion using MADM approach," *Journal of J Hazard Mater*, Vol. 186, No. 2-3, Pp. 2009-2016, (2009).
- [19] Karellas S, Boukis I, Kontopoulos G, "Development of an investment decision tool for biogas production from agricultural waste," *Journal of Renew Sust Energ Rev*, Vol. 14, No. 4, Pp. 1273-1282, (2010).
- [20] Zingoni A, "Shell forms for egg-shaped concrete sludge digesters: A comparative study on structural efficiency," *Journal of Struct Eng Mech*, Vol. 19, No. 3, Pp. 321-336, (2010).
- [21] Banks CJ, Salter AM, Heaven S, Riley K, "Energetic and environmental benefits of co-digestion of food waste and cattle slurry: A preliminary assessment," *Journal of Resour Conserv Recy*, Vol. 56, No. 1, Pp. 71-79, (2011).

- [22] Esposito G, Frunzo L, Panico A, Pirozzi F, “Model calibration and validation for OFMSW and sewage sludge co-digestion reactors,” *Journal of Waste Manage*, Vol. 31, No. 21, Pp. 2527-2535, (2011).
- [23] Krishna R, “Adsorptive separation of CO₂/CH₄/CO gas mixtures at high pressures,” *Journal of Micropor Mesopor Mat*, Vol. 156, Pp. 217-223, (2012).
- [24] Rehl T, Müller J. Life cycle assessment of biogas digestate processing technologies. *Resour Conserv Recy*.56 (1) (2011)92–104.
- [25] Rittmann BE, Mayer B, Westerhoff P, Edwards M. Capturing the lost phosphorus. *Chemosphere*.84 (6) (2011)846-53.
- [26] Rehl T, Müller J, “Life cycle assessment of biogas digestate processing technologies,” *Journal of Resour Conserv Recy*, Vol. 56, No. 1, Pp. 92-104, (2011).
- [27] Rasi S, Läntelä J. Veijanen A, Rintala J, “Landfill gas upgrading with countercurrent water wash,” *Journal of Waste Manage*, Vol. 28, No. 9, Pp. 1528-1534, (2012).
- [28] Anozie AN, Layokun SK, Okeke CU, “An evaluation of a batch pilot-scale digester for gas production from agricultural wastes,” *Journal of Energy Source*, Vol. 27, No. 14, Pp. 1301-1311, (2005).
- [29] Guha D, “Anchored enzymes in biogas generation,” *Journal of the ACS National Meeting Book of Abstracts*, Vol. 238, Pp. 979-984, (2009).
- [30] Köppel, W, “Biogas treatment for SNG production,” *Journal of Int Gas Res Conf Proceedings*, Vol. 2, Pp. 1327-1345, (2008).
- [31] Rapport JL, Zhang R, Jenkins BM, Hartsough BR, Tomich TP, “Modeling the performance of the anaerobic phased solids digester system for biogas energy production,” *Journal of Biomass Bioenerg*, Vol. 35, No. 3, Pp. 1263-1272, (2011).
- [32] Kamarudin SK, Daud WRW, Som AM, Mohammad AW, Takriff S, Masdar MS. The conceptual design of a PEMFC system via simulation. *Chem Eng J*.103 (1-3) (2004)99-113.
- [33] <http://hydrogencontest.org/pdf/AOG%20Composition%20Example.pdf>.2012
“Anode Outlet Gas Composition Calculation Example,”
- [34] Kinoshita CM, Turn SQ, Overend RP, Bain RL, “Power generation potential of biomass gasification systems,” *Journal of J Energy Eng*, Vol. 123, No. 3, Pp. 88-113, (1997).

III HYDROGEN RECOVERY, CLEANING, COMPRESSION, STORAGE, DISPENSING, DISTRIBUTION SYSTEM AND END-USES ON THE UNIVERSITY CAMPUS FROM COMBINED HEAT, HYDROGEN AND POWER SYSTEM

Tarek A. Hamad, John W. Sheffield

Department of Mechanical and Aerospace Engineering, Missouri University of Science and Technology, 400 W 13th Street, Rolla, MO 65409-0050, USA

Received 26 August 2013

Received in revised form 12 October 2013

Accepted 19 October 2013

ABSTRACT

To address the problem of fossil fuel usage at the Missouri University of Science and Technology campus, using of alternative fuels and renewable energy sources can lower energy consumption and hydrogen use. Biogas, produced by anaerobic digestion of wastewater, organic waste, agricultural waste, industrial waste, and animal by-products is a potential source of renewable energy. In this work, we have discussed the design of combined heat, hydrogen and power (CHHP) system for the campus using local resources. An energy flow and resource availability study is hydrogen recovery, cleaning and energy End-Uses on the university campus from CHHP system. Following the resource assessment study, our team selects FuelCell Energy direct fuel cell (DFC) 1500TM unit as a molten carbonate fuel cell. The CHHP system provides the hydrogen for transportation, back-up power and other needs. The research presented in this paper was performed as part of the 2012 Hydrogen Student Design Contest. In conclusion, the CHHP system will be able to reduce fossil fuel usage, greenhouse gas (GHG) emissions and hydrogen generated is used to power different applications on the university campus.

Keywords: A molten carbonate, Renewable energy, CHHP system, Hydrogen and heat recovery, Hydrogen End-Uses

1. INTRODUCTION

The Missouri University of Science and Technology (Missouri S&T) campus in Rolla, Missouri, USA is a relatively small campus with 1.15 km² and approximately 6,500 students on campus. The university is one of the City of Rolla's largest electric power consumers with a peak demand of 6.36 MWe and annual electric energy consumption of 2.55×10^6 kWh/yr. Currently, electrical power for the university campus is purchased from Rolla Municipal Utilities (RMU) and distributed from the substation and switchgear located at the campus power plant. In addition, the university thermal power plant generates electricity with a back pressure steam turbine, accounting for an additional 10% of electricity. The CHHP system design was centered on a molten carbonate fuel cell stack (DFC 1500™ from Fuel Cell Energy in this study); biogas produced by anaerobic digestion of municipal solid waste (MSW) and organic waste from university campuses, surrounding municipalities and industries is a potential source of renewable energy. The research presented in this paper was performed as part of the 2012 Hydrogen Student Design Contest to investigate the use of a CHHP system at (Missouri S&T) campus, it should be noted that the contest rules specified the use of either a DFC1500™ or DFC300™ or both based on a biogas with 60% methane and 40% carbon dioxide. The power generated by the CHHP system is used at various locations on the campus [1–3]. In addition, the CHHP system has higher efficiency than other distributed generation plants of similar size [4, 5]. The CHHP system attains ultra-high efficiency about 60-75% power and reducing gas. In this paper, we have discussed the hydrogen recovery, cleaning, compression, storage, dispensing, distribution system and End-Uses on the university campus from CHHP system. The generated hydrogen is used personal transportation, backup power, portable power, and mobility/utility applications. Locally available feedstocks near the Missouri S&T campus that can be used for biogas production were identified. An energy flow and resource availability study was performed to identify the type and source of feedstock required to continuously run the CHHP system to produce maximum capacity of electricity, heat recovery and hydrogen.

2. DFC[®] TECHNOLOGY STATUS.

Fuel Cell Energy offers three DFC[®] products; the DFC 300[™], DFC 1500[™], and DFC 3000[™], which are 350 kW, 1.4 MW, and 2.8 MW, power plants, respectively [6]. The DFC[®] 1500[™] matches up well with the needs of a wastewater treatment plant, or a food processing facility where methane produced by anaerobic digestion can be efficiently utilized to produce electricity [7-11]. The DFC[®] technology offers higher net electrical efficiency and a cleaner exhaust stream when operating on biogas from an anaerobic digester than any competing conventional technology such as reciprocating engines or gas turbines. The DFC[®] systems also have a good heat-to-power ratio for support of digester operations. Following the resource assessment study, the team selects Fuel Cell Energy DFC1500[™] unit as a molten carbonate fuel cell [12, 13].

2.1. ANAEROBIC DIGESTION SYSTEM

The digester used in the design is a complete-mix anaerobic digester from Siemens and is a concrete tank with a diameter of 30.5 m and a tank side water depth of 12.8 m. The tank wall height below grade, cone per, and wall thickness are 14.6 m, 892 m³, and 0.30 m respectively. The digester has a floor slope of 1:6 and the quantity of solids to digester is 27×10^3 kg/day. The outer wall is insulated and the inner wall of the tank is lined with stainless steel hot water pipes to maintain an optimum temperature of 40 °C. The design uses a highly efficient JetMix[™] Vortex Mixing System by Siemens, to mix the biomass inside the digester. The system suspends organic and inorganic solids with intermittent mixing, making possible power savings of up to 50% or more. The system maintains efficiency regardless of tank level and minimizes dead spots due to its innovative mixing pattern and also has the capability to mix multiple tanks using one central pumping facility. This system will eliminate the use of multiple pumps and will reduce the capital cost of the digester system. The proposed anaerobic digester is sized such that it has retention time of 20 days. Moreover, the volatile solids concentration, anticipated solids reduction, and anticipated gas yield (volatile solids destroyed) are 80%, 50%, and 0.93 m³/kg respectively.

Inside the anaerobic digester, microorganisms act on the organic feedstock to produce biogas, digestate, and water. The anticipated biogas production from the digester is 425 m³/h or 260 m³/h of natural gas equivalent (assuming biogas

concentration is 60% methane and 40% carbon dioxide). The value of mass flow rate, solids destroyed, digested solids (dry), total required tank capacity, and organic loading are 0.614 kg/day, 11×10^3 kg/day, 16×10^3 kg/day, 9×10^3 m³, and 0.0093 kg /m³ respectively of the digested sludge from the anaerobic digester. The digestate from the anaerobic digester is pumped to the storage tank and is stored there until it is ready to be collected and transported to the facility. The storage tank is also an insulated concrete tank and can also be used to store biogas if the buffer tank holding the biogas is full.

2.2. GAS TREATMENT SYSTEM AND FUEL STORAGE

Biogas from the anaerobic digestion is stored in a buffer tank which supplies biogas to the gas treatment system. The treatment system uses pressure swing adsorption (PSA) technology to separate methane present in the biogas [2, 15-17]. The design has a total of four absorbers to ensure a continuous stream of high quality methane. While carbon dioxide (CO₂), hydrogen sulfide (H₂S) and other impurities in one set of tanks are desorbing, biogas will be fed to the second set of tanks for adsorption. The product from this gas treatment system is pipe line quality natural gas which is fed into the fuel cell. Even though the DFC[®] fuel cell units can handle 60% methane and 40% carbon dioxide without affecting its efficiency, the design included the PSA unit for the following reasons:

1. The DFC[®] fuel cell units cannot accept H₂S, water (H₂O), and other impurities in its input fuel. Therefore, biogas treatment is necessary before feeding it into the fuel cell under all conditions.
2. Inlet fuel pressure to the fuel cell should be between 2 – 2.4 bar. If the fuel contains 40% carbon dioxide, it will impact the sizing of the equipment downstream the fuel cell of the design will require a higher capacity heat exchanger, water gas shift reactor, and hydrogen purification or separation system.
3. The biogas output from the digester can vary due to disruption in the feedstock availability or other unforeseeable reasons. In this case, the system will have to use natural gas purchased from utility company to provide any unmet fuel demand by the fuel cell. It was estimated that the systems downstream the

fuel cell will run at 78.5% of its normal capacity if the fuel quality changes from 100% biogas to 50% biogas and 50% natural gas.

- The product gas from the PSA unit is expected to have an average heat content of 37 MJ/m^3 which is roughly equal to the average heat content of natural gas consumed in Missouri (38 MJ/m^3) through 2007–2010. Hence, the fuel cell unit will receive a consistent fuel throughout its operation. The process and flow during the biogas treatment is depicted in Fig. 1.

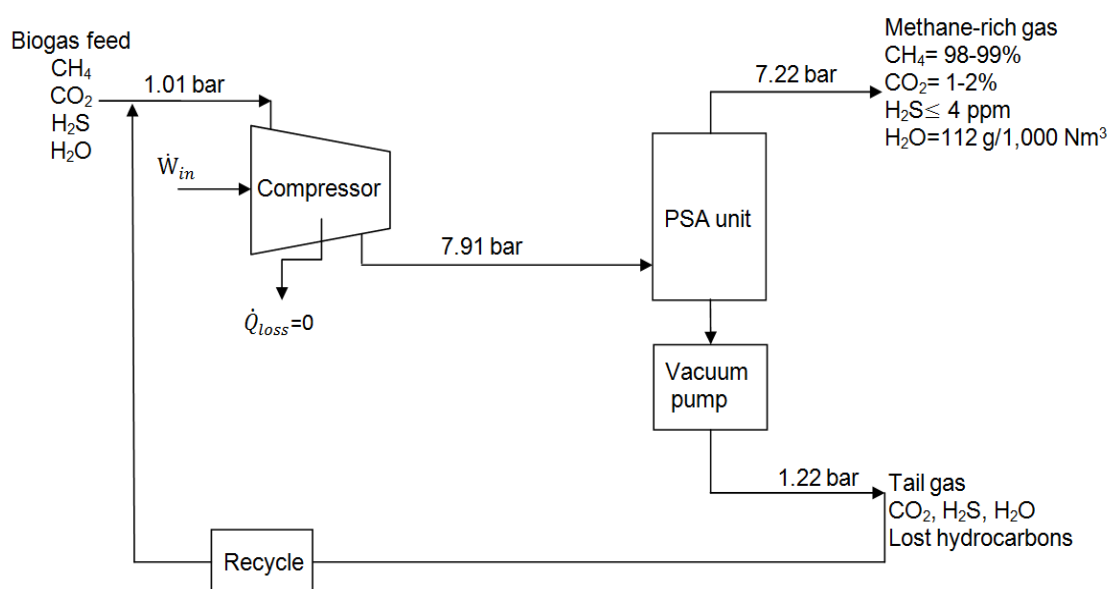

Figure 1. Biogas treatment process diagram

2.3. DFC1500TM FUELCELL POWER PLANT

The anaerobic digester system will be able to supply 90% of fuel for the DFC1500TM unit from locally available feedstock. The remaining 10% fuel required will be purchased from the utility company. In order to accommodate the fluctuations in gas quality, the natural gas used in the design is assumed to contain 98% methane and 2% carbon dioxide (with an average heating value of 37 MJ/m^3). Figure 2 shows the reactions taking place inside the fuel cell [2, 6].

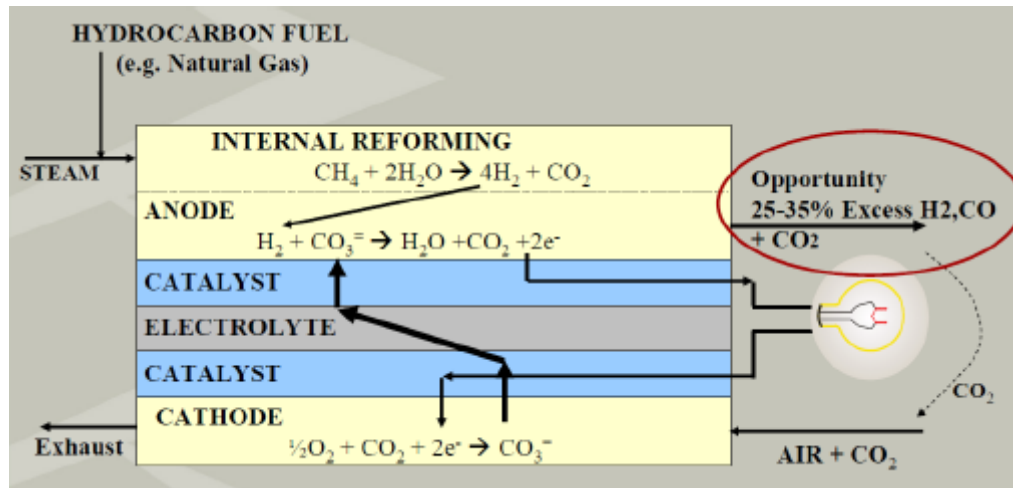

Figure 2. Internal reforming DFC[®] technology

2.3.1. Anode Outlet Gas (AOG) Calculations. The anode outlet gas calculations are made based on the AOG composition calculation document provided by FuelCell Energy [17]. It is assumed that all methane entering the DFC[®] unit is internally reformed and converted to hydrogen and that only 65% (the fuel utilization rate) of the H₂ produced is reacted at the anode to produce electricity. In order to reflect the AOG composition, it is assumed that one third of the 35% hydrogen produced is back-shifted to produce H₂O and CO. Based on these assumptions and the processes taking place inside the fuel cell, the following equations (1 – 5) for every one mole of methane (CH₄) entering the anode side are obtained[1].

Internal reforming:



Assuming one mole of CH₄ is fed to the DFC[®] system; four moles of hydrogen will be produced [1, 17]. But, only 65% of the hydrogen (i.e. 2.6 moles) reacts at the anode and will result in the following equation.

Corresponding reaction at anode:

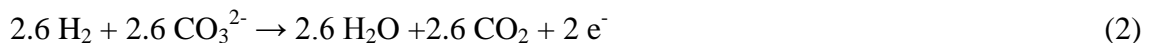

The remaining 35% of the H₂ (1.4 moles) and the entire CO₂ (1 mole) from equation (1) goes directly to the AOG. Combining the products from (2) and 1.4 moles of H₂ and 1 mole of CO₂ from (1) results in the following AOG composition.



But in reality, another internal reaction takes place in the DFC[®] fuel cell. One third of the H₂ in equation (3) (i.e. 0.47 moles) needs to be back-shifted to H₂O and CO resulting in equation (4) [17].



Combining equations (3) and (4) yields the following products:

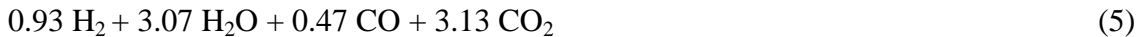

Hence for every one mole of CH₄ the following AOG composition is obtained as on a molar percentage basis H₂O, CO₂, CO and H₂ are 40.4, 41.2, 6.2, and 12.2 respectively with assuming 100% CH₄. The inlet fuel requirement of the DFC1500[™] unit based on 156 MJ/m³ input fuel is calculated and found to be 286 m³/h consists of 198 moles of CH₄ and 4 moles of CO₂. The actual AOG flowrate of methane (mol/min) for H₂, H₂O, CO, and CO₂ is calculated using equation (5) are 156.5, 516.8, 79.1 and 526.9 respectively.

2.3.2. Hydrogen Recovery and Cleaning System. In order to achieve a CHHP system, hydrogen from the AOG must be recovered, cleaned and distributed from the DFC[®] fuel cell system. The details of the hydrogen recovery and purification process are shown in Fig. 3.

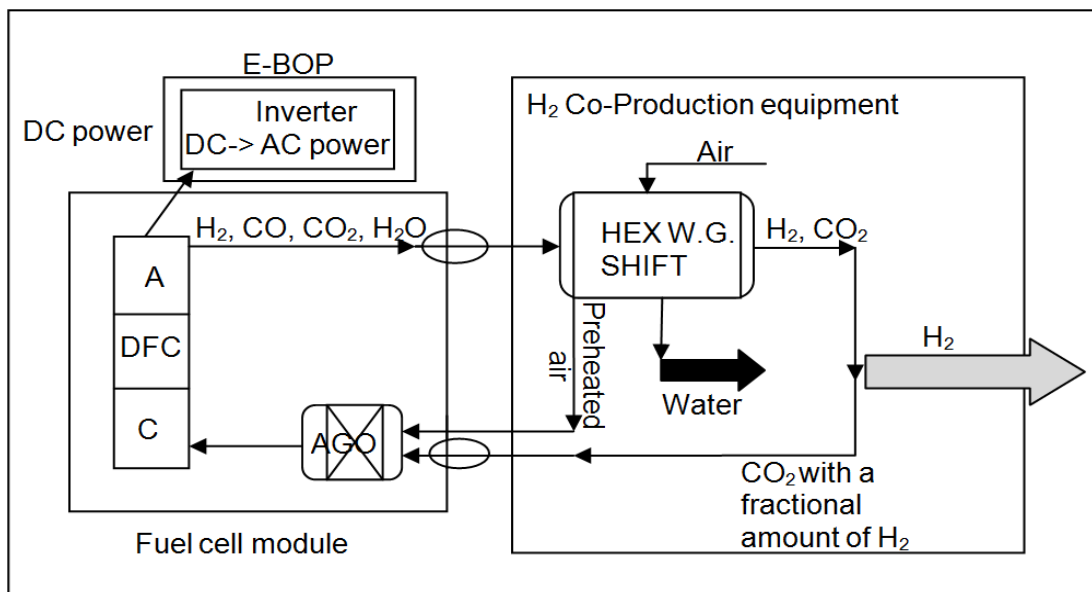

Figure 3. Hydrogen recovery and purification

The AOG outlet pressure is 1.08 bar and outlet temperature to be 600 °C. The AOG is first cooled and pressurized to undergo water-gas shift reaction.

Water-gas shift reaction:



The entire CO present in the AOG reacts with H₂O to produce an additional 242 kg of H₂ and of 4×10³ kg of CO₂ per day. The water vapor is condensed and recycled to the anode side of the fuel cell for the internal reforming of methane. The amount of water produced during condensation is greater than the fuel cell requirement with the excess water is sent into the sewer. The CO₂ and H₂ coming out of the water-gas shift reactor is cooled and separated using a PSA unit. The hydrogen coming out of the PSA unit is compressed and used for different applications on the university campus. Outside air is preheated using the heat exchanger and is mixed with the CO₂ coming out the PSA unit in AGO. The mixture is then transferred to the cathode to complete the cathode reaction as shown in equation (7).

Reaction at cathode:



The flow rates of gases at different stages were tabulated in Table 1. These flow rates are necessary to calculate the amount of hydrogen generated, amount of outside air needed, and amount of exhaust gas. The following assumptions were made during the calculations: (i) H₂ recovery rate from PSA unit is 90%; (ii) N₂ is inert and does not take part in the cathode reactions; (iii) amount of outside air was calculated based on the amount of CO₂ present on the PSA tail gas; (vi) only 70% of CO₂ undergoes reaction to maintain the CO₃²⁻ equilibrium inside the fuel cell. Based on the hydrogen flow rate from the PSA product outlet, the amount of hydrogen generated per day is approximately 650 kg [1, 12].

Table 1. Flow of gases at different sections of the system

Gas	HEX W.G. shift inlet (mol/min)	HEX W.G. shift outlet (mol/min)	PSA product outlet (mol/min)	PSA tail gas (mol/min)	AGO inlet (mol/min)	cathode exhaust (mol/min)
H ₂	156.5	235.6	212	23.6	23.6	23.6
CO ₂	526.9	606	-	606	606	181.8
H ₂ O	516.8	437.7	-	-	-	-
CO	79.1	-	-	-	-	-
O ₂	-	-	-	-	303	90.9
N ₂	-	-	-	-	1,140	1,140

2.3.3. Heat Recovery. The heat energy available for recovery from the DFC1500TM unit working in the CHHP mode is relatively lower than the DFC1500TM unit working in the combined heat and power (CHP) mode. This is due to the losses associated with the hydrogen recovery. Heat is recovered from the fuel cell exhaust gas using an air to water heat exchanger and will be transported to various locations as hot water [3, 12]

2.4. HYDROGEN COMPRESSION, STORAGE, DISPENSING / DISTRIBUTION SYSTEM

The design will incorporate the system into the existing hydrogen infrastructure on the university campus. The existing hydrogen station was designed such that it could handle higher volume of hydrogen in the future. Currently, the hydrogen fueling station at the E3 Commons area has an electrolyzer capable of producing 4.2 kg of hydrogen per day, cascade storage tanks that can hold 33 kg of hydrogen at 450 bar, a hydrogen compressor capable of compressing 15 kg of hydrogen per day to 415 bar, and a 350 bar hydrogen dispenser. The product hydrogen from the PSA unit will be transferred into the buffer tank located in the adjacent hydrogen station via pipeline. The buffer tank feeds two compressors; (i) the existing Hydro-Pac C06-10-70/140LX compressor (415 bar) and (ii) the PDC machines (PDC-13-1000-3000) compressor (250 bar). The compressed hydrogen from the Hydro-Pac compressor will be stored in existing storage tanks. Hydrogen from the PDC machine compressor will be used to fill a hydrogen tube trailer and K-cylinder manifold. The end use of hydrogen is discussed in the next section. The entire process of hydrogen compression, storage, dispensing and distribution is shown in Fig. 4.

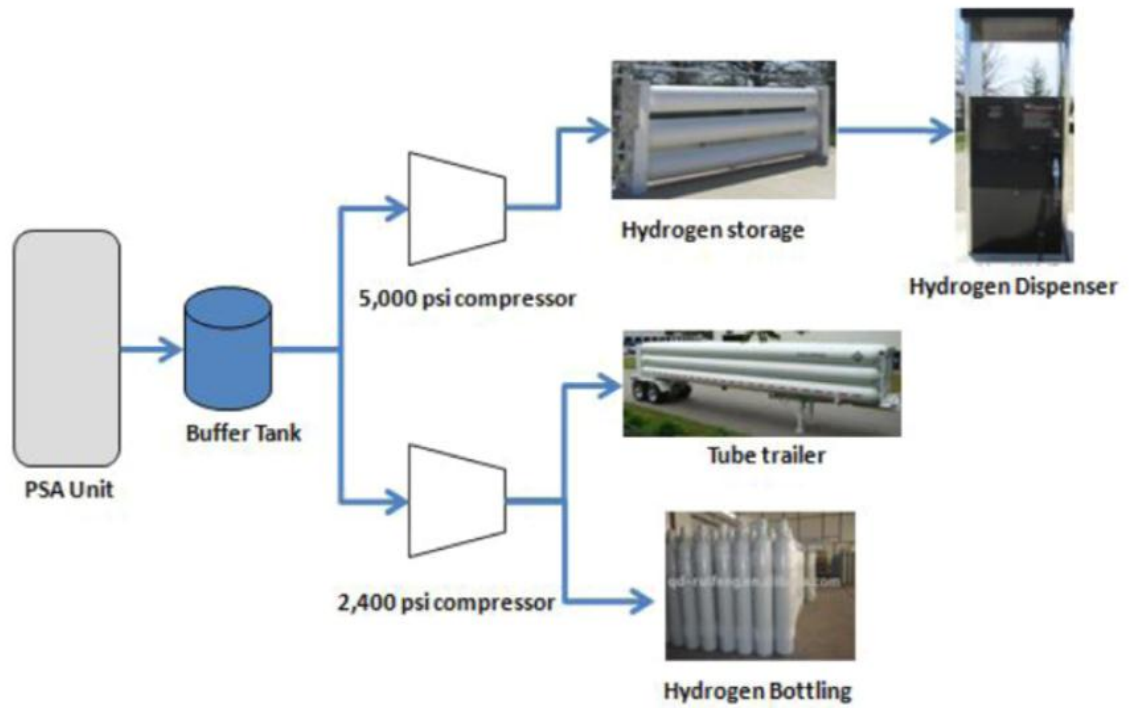

Figure 4. Hydrogen compression, storage, and dispensing

3. RESULTS AND DISCUSSION

3.1. HYDROGEN END-USES

Our team identified many end uses for hydrogen use (kg/day) on the university campus including personal transportation applications, backup power applications, portable power applications, and other mobility applications are 56, 16, 29, 17, and 5 respectively. The different applications, potential users, and total hydrogen usage per day (123 kg/day) are shown in Fig. 5.

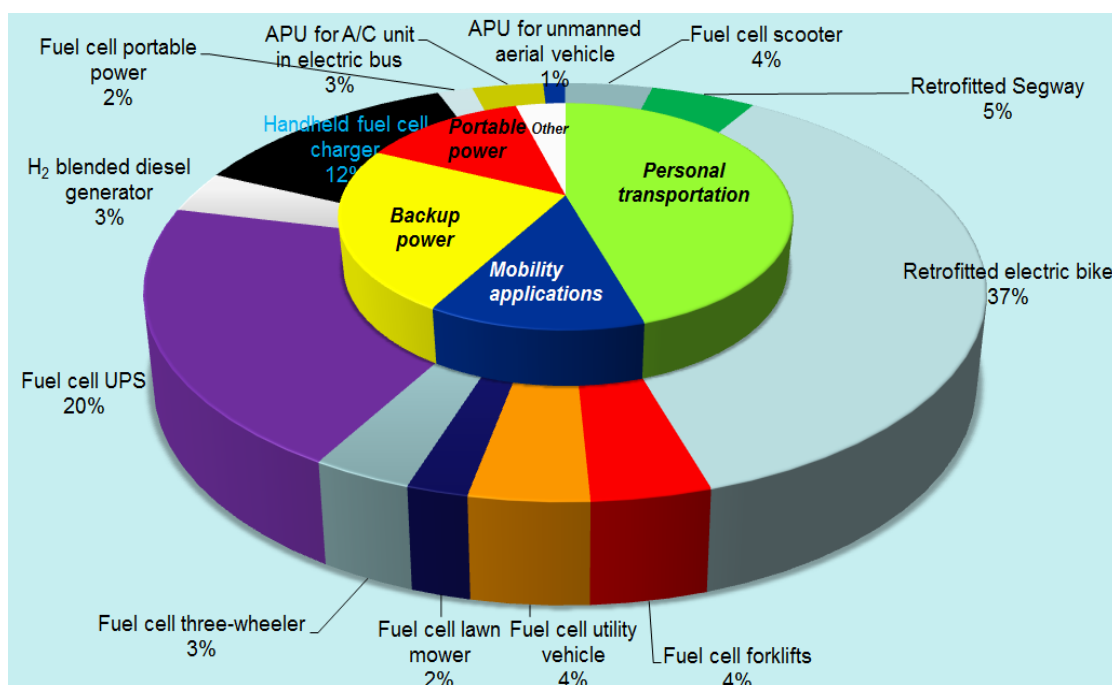

Figure 5. Percentage daily range hydrogen application and usage on the university campus

The major use of the hydrogen on the university campus is for fueling personal transporters. They include fuel cell scooters, Segways and electric bikes retrofitted with fuel cells (fig. 6).

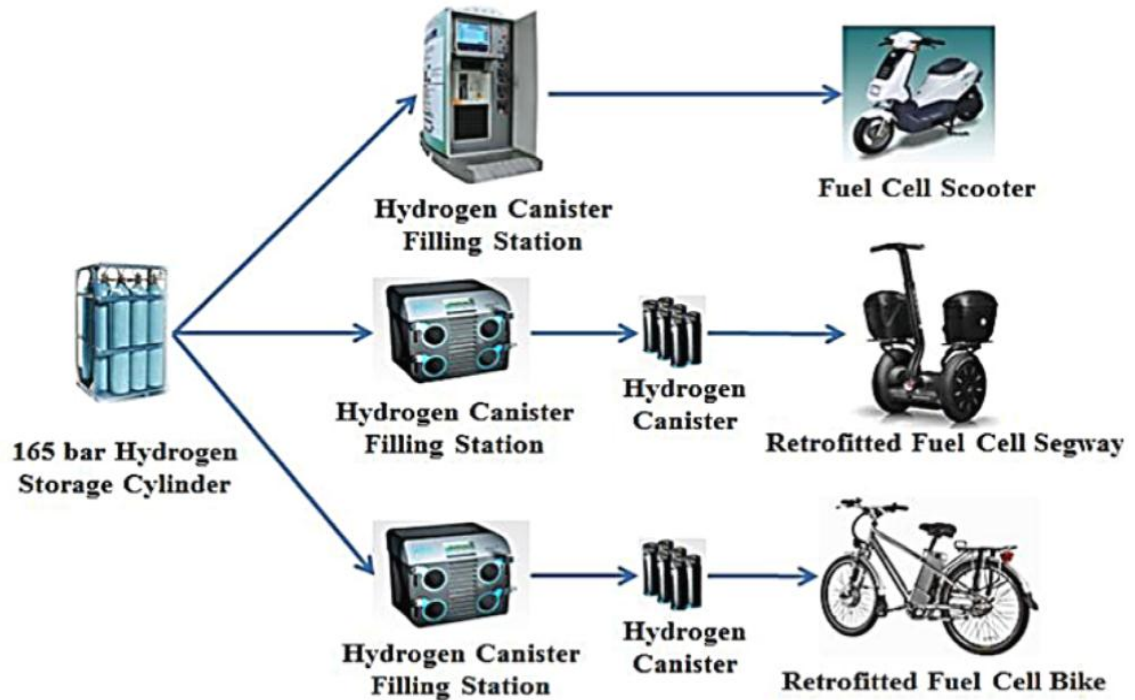

Figure 6. Personal transportation

The Segways and electric bikes will be retrofitted in-house at the hydrogen research and development garage. The retrofitted Segways and bikes will have fuel cells that act as range extenders for the on-board batteries and will recharge it when the state of charge falls below a certain set value. The Segway will be also used by university police for patrolling the university campus. The Segway retrofitted with fuel cell provides longer run time between recharging and can even operate without the need for electric recharging as long as hydrogen fuel is supplied to the fuel cell. The design also incorporates different hydrogen mobility applications for the university campus (fig. 7).



Figure 7. Hydrogen powered mobility applications

The hydrogen powered people transporter is a zero emission vehicle will be used to transport the university campus tours and to raise awareness about Green initiatives on the university campus. The fuel cell forklifts and fuel cell utility vehicle will be primarily used by “physical facilities” which provides campus support by maintaining and operating campus buildings, sidewalks, parking lots, and other facilities around the university campus. The landscaping unit will use a fuel cell lawn mower to maintain the university campus green areas on the university campus. Another innovative idea used is the blending of hydrogen with diesel while running backup diesel generators. Blending small percentage of hydrogen with diesel fuel has shown to reduce the total fuel consumption of the generator and reduced emissions [7, 18]. Portable power and on-the-go recharging of personal electronic appliances such as cell phones, laptops, iPod’s, etc. is desirable in the current technological age. The team has included portable power units (Fig. 8) understanding the demands of the customers on the university campus.

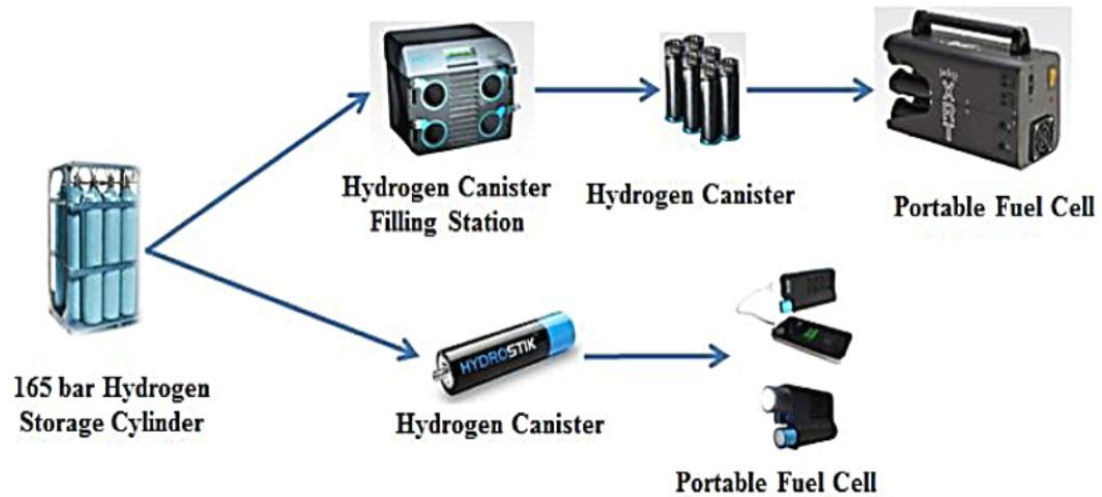

Figure 8. Hydrogen Fuel cell portable power application

The portable power modules and the handheld fuel cell charger will be available to the students, faculty, and staff for checkout from the Department of Student Life office as well the outdoor activities. The fuel cell portable power will be able to reduce the great replacement for the battery operated equipment for camping and outdoor activities.

3.2. CHHP HYDROGEN OUTPUT

As mentioned in section 3.1 a total of 123 kg of hydrogen will be used per day to displace the conventional fuel. The fuel displaced by this hydrogen, the energy services provided by the hydrogen, and amount of fuel displaced is identified and tabulated in Table 2. All the calculations take into consideration the estimated hours of operation of the equipment.

Table 2. Avoided conventional fuel details [2]

Application	Fuel displaced	Energy services provided by utilizing hydrogen (per year)	Amount of conventional fuel avoided (TJ/yr)
Fuel cell forklifts	diesel	630 MWh	73.6
Backup power UPS	diesel	210 MWh	588
H ₂ blended diesel generator	diesel	-	563
Handheld fuel cell charger	central station electricity	331 MWh	3.80
Portable power	central station electricity		
APU for AC unit in electric bus	diesel	548 MWh	94.0
Fuel cell three-wheeler	gasoline	7343 km	270
Fuel cell scooter	gasoline	29,371 km	85.5
Retrofitted electric bike	none	5.50 MWh	0.00
Retrofitted Segway	central station electricity	408 MWh	4.70
Fuel cell utility vehicle	gasoline	841 MWh	25.0
Fuel cell lawn mower	gasoline	383 MWh	12.0

4. CONCLUSION

This study shows the hydrogen recovery, cleaning and energy End-Uses on Missouri S&T campus from CHHP system by using local resources. Following the resource assessment study, the team selects FuelCell Energy DFC1500TM unit for its fuel cell. The results indicated the CHHP system will be able to provide 650 kg of hydrogen to the university campus per day and reduce energy consumption, fossil fuel usage and greenhouse gas (GHG) emissions at the Missouri S&T campus. The CHHP system provides hydrogen (kg/day) on the university campus including personal transportation applications, backup power applications, portable power applications, and other mobility applications are 56, 16, 29, 17, and 5 respectively. The excess hydrogen could be sold to a gas retailer. The retailer will collect the compressed hydrogen from the facility and will distribute it to its customers in the surrounding area.

ACKNOWLEDGMENTS

The authors wish to acknowledge the Hydrogen Education Foundation for their support of the annual Hydrogen Student Design Contest which challenges university students to design hydrogen energy applications for real-world use.

APPENDIX A. SUPPLEMENTAL DATA

The full report submission for the Hydrogen Education Foundation's Hydrogen Student Design Contest is available online: <http://hydrogencontest.org/previous.asp>.

REFERNCES

- [1] Hamad TA, Agll AA, Hamad YM, Bapat S, Thomas M, Martin KB, et al, "Study of a molten carbonate fuel cell combined heat, hydrogen and power system: End-use application," *Journal of Case Studies in Thermal Engineering*, Vol. 1, Pp. 45-50, (2013).
- [2] Agll AA, Hamad YM, Hamad TA, Bapat S, Thomas M, Martin KB, et al, "Study of a molten carbonate fuel cell combined heat, hydrogen and power system: Energy analysis," *Journal of App Thermal Eng*, Vol. 59, Pp. 634-638, (2013).
- [3] Yu M , Muy S, Quader F, Bonifacio A, Varghese R , Clerigo E, et al, "Combined Hydrogen, Heat and Power (CHHP) pilot plant design," *Journal of Int J Hydrogen Energy*, Vol. 38, No.12, Pp. 4881-4888, (2013).
- [4] Braun R J, "Techno-economic optimal design of solid oxide fuel cell systems for micro-combined heat and Power applications in the U.S.," *Journal of J Fuel Cell Sci Technol.*, Vol. 7, No. 3, Pp. 0310181-03101815,(2013).
- [5] Ghezel-Ayagh H, McInerney J, Venkataraman R, Farooque M, Sanderson R, "Development of direct carbonate fuel cell systems for achieving ultrahigh efficiency," *Journal of J Fuel Cell Sci Tech.*, Vol. 8, No. 3, Pp. 031011
- [6] Daly J, Steinfeld G, Moyer DK, Holcomb FH, "Molten carbonate fuel cell operation with dual fuel flexibility" *Journal of J Power Sources*, Vol. 173, No. 2, Pp. 925-34, ,(2007).
- [7] Bang-Møller C, Rokni M, Elmegaard B, "Exergy analysis and optimization of a biomass gasification, solid oxide fuel cell and micro gas turbine hybrid system," *Journal of Energy*, Vol. 36, Pp. 4740-4752, ,(2011).
- [8] Kuchonthara P, Bhattacharya S, Tsutsumi A, "Combination of thermochemical recuperative coal gasification cycle and fuel cell for power generation," *Journal of Fuel*, Vol. 84, Pp. 1019-1021,(2005).
- [9] Aki H, Taniguchi Y, Tamura I, Kegasa A, Hayakawa H, Ishikawa Y, et al, "Fuel cells and energy networks of electricity, heat, and hydrogen: a demonstration in hydrogen-fueled apartments," *Journal of International Journal of Hydrogen Energy*, Vol. 37, Pp. 1204-1213,(2012).
- [10] Grassi G, Bridgwater A, "The opportunities for electricity production from biomass by advanced thermal conversion technologies," *Journal of Biomass and Bioenergy*, Vol. 4, Pp. 339-345, (1993).

- [11] Faaij A, Van Ree R, Waldheim L, Olsson E, Oudhuis A, Van Wijk A, et al, "Gasification of biomass wastes and residues for electricity production," *Journal of Biomass and Bioenergy*, Vol. 12, Pp. 387-407, (1997).
- [12] Spencer JD, Moton JM, Gibbons WT, Gluesenkamp K, Ahmed II, Taverner AM, et al, "Design of a combined heat, hydrogen, and power plant from university campus waste streams," *Journal of Int J Hydrogen Energy*, Vol. 38, Pp. 4889-4900, (2013).
- [13] Pecha B, Chambers E, Levengood C, Bair J, Liaw S, Leachman J, et al, "Novel concept for the conversion of wheat straw into hydrogen, heat, and power: A preliminary design for the conditions of Washington State University," *Journal of Int J Hydrogen Energy*, Vol. 38, Pp. 4967-4974, (2013).
- [14] Krishna R, "Adsorptive separation of CO₂/CH₄/CO gas mixtures at high pressures," *Journal of Micropor Mesopor Mat*, Vol. 156, Pp. 217-223, (2012).
- [15] Adhikari S, Fernando S, "Hydrogen separation from synthesis gas," *Journal of ASAE Annu Int Meeting*, (2005).
- [16] Locher C, Meyer C, Steinmetz H, "Operating experiences with a molten carbonate fuel cell at stuttgart-möhringen wastewater treatment plant," *Journal of Water Sci Technol.*, Vol. 65, No.5, Pp. 789-794, (2012).
- [17] <http://hydrogencontest.org/pdf/AOG%20Composition%20Example.pdf> Anode Outlet Gas Composition Calculation Example:
- [18] Chandler K, Eudy L, "Connecticut transit (CTTRANSIT) fuel cell transit bus: third evaluation report," *Journal of National Renewable Energy Laboratory*, (2010).

IV HYDROGEN PRODUCTION AND END-USES FROM COMBINED HEAT, HYDROGEN AND POWER SYSTEM BY USING LOCAL RESOURCES

Tarek A. Hamad, John W. Sheffield

Department of Mechanical and Aerospace Engineering, Missouri University of Science and Technology, 400 W 13th Street, Rolla, MO 65409-0050, USA

Received 4 September 2013

Accepted 24 May 2014

ABSTRACT

To address the problem of fossil fuel usage at the Missouri University of Science and Technology campus, using of alternative fuels and renewable energy sources can lower energy consumption and hydrogen use. Biogas, produced by anaerobic digestion of wastewater, organic waste, agricultural waste, industrial waste, and animal by-products is a potential source of renewable energy. In this work, we have discussed Hydrogen production and End-Uses from CHHP system for the campus using local resources. Following the resource assessment study, the team selects FuelCell Energy DFC1500TM unit as a molten carbonate fuel cell to study of combined heat, hydrogen and power (CHHP) system based on a molten carbonate fuel cell fed by biogas produced by anaerobic digestion. The CHHP system provides approximately 650 kg/day. The total hydrogen usage 123 kg/day on the university campus including personal transportation applications, backup power applications, portable power applications, and other mobility applications are 56, 16, 29, 17, and 5 respectively. The excess hydrogen could be sold to a gas retailer. In conclusion, the CHHP system will be able to reduce fossil fuel usage, greenhouse gas emissions and hydrogen generated is used to power different applications on the university campus.

Keywords: Renewable energy, Hydrogen production, CHHP system, Hydrogen recovery, Hydrogen End-Uses

1. INTRODUCTION

The Missouri University of Science and Technology (Missouri S&T) campus in Rolla, Missouri, USA is a relatively small campus with 1.15 km² and approximately 6,500 students on campus. Biogas produced by anaerobic digestion of wastewater, organic waste, agricultural waste, and industrial waste is a potential source of renewable energy. Treated biogas can be used to generate CHHP using a molten carbonate fuel cell. The paper investigates the use of a CHHP system at (Missouri S&T) campus, and we have discussed the Hydrogen production, recovery, cleaning, and End-Uses on the university campus from CHHP system by using local resources. The hydrogen generated by the CHHP system is used personal transportation, backup power, portable power, and mobility/utility applications at various locations on the campus [1–4]. The research presented in this paper was performed as part of the 2012 Hydrogen Student Design Contest. In addition, the performance assessment of the CHHP system has higher efficiency than other distributed generation plants of similar size [5, 6]. The CHHP system attains ultra-high efficiency about 60-75% power and reducing gas [1].

2. RESOURCE ASSESSMENT

2.1. FEEDSTOCK SOURCE IDENTIFICATION

During the assessment, “locally available feedstock” was defined as one which is within 20 km of Rolla. The largest source of locally available feedstock is MSW averaging 60 tons/day. Of this, approximately 33% is organic waste including 17% food waste. The campus plans to partner with the City of Rolla and will start an “Organic Waste Collection Program” to collect organic waste. Currently, the city offers residential curbside collection of recyclable materials at no extra cost.

Potential feedstock from the campus includes food waste and sanitary sewer. Food waste collected daily is mixed with the trash and the sanitary sewer and is connected to the city’s main sewer lines. Methods for feedstock collection, transportation, and storage were also identified and are tabulated in Table 1[7, 8].

Table 1. Feedstock availability, collection, transportation and storage

Type of feedstock	Source	Collection		Transportation	Storage
		Frequency	Collection point		
Dog and cat food waste	Royal Canin	daily	warehouse	semi-trailer	Facility A
Food waste	University courts	daily	food court	pickup truck	Facility A
Wood chips	university power plant	daily	delivered at site	trailer truck	Facility A
Waste water	SE Wastewater Treatment Plant	daily	delivered at site	used at facility	Facility B
MSW	Rolla municipal solid waste	weekdays	organic waste collection program	trash truck	Facility A
Brewery waste	Public House Brewery	weekly	brewery	pickup truck	Facility A
Grape skin, rice hull and vines	St. James Winery	seasonal	winery/vineyard	semi-trailer	Facility A
Timber	MTNF	seasonal	MTNF	trailer truck	Facility A

3. EXPERIMENTAL PROCEDURE

3.1. DFC[®] TECHNOLOGY STATUS.

FuelCell Energy offers three DFC[®] products; the DFC 300[™], DFC 1500[™], and DFC 3000[™], which are 350 kW, 1.4 MW, and 2.8 MW, power plants, respectively. The DFC[®] 1500[™] matches up well with the needs of a wastewater treatment plant, or a food processing facility where methane produced by anaerobic digestion can be efficiently utilized to produce electricity.

The DFC[®] technology offers higher net electrical efficiency and a cleaner exhaust stream when operating on biogas from an anaerobic digester than any competing conventional technology such as reciprocating engines or gas turbines. The DFC[®] systems also have a good heat-to-power ratio for support of digester operations.

The design discussed in this paper has three major systems: (i) anaerobic digestion system, (ii) CHHP system consisting of a DFC1500[™] fuel cell unit, and (iii) hydrogen compression, storage, and dispensing system [1-3].

3.2. ANAEROBIC DIGESTION SYSTEM

Digester and biogas production are shown in Fig. 1 [2, 3, 9]. Biogas from the anaerobic digestion is stored in a buffer tank which supplies biogas to the gas treatment system. The treatment system uses pressure swing adsorption (PSA) technology to separate methane present in the biogas [10, 11]. The design included the PSA unit for the following reasons [1-3, 8]:

- i. The DFC[®] fuel cell units cannot accept H₂S, water (H₂O), and other impurities in its input fuel [12].
- ii. Inlet fuel pressure to the fuel cell should be between 2 – 2.4 bar [9, 13].
- iii. The biogas output from the digester can vary due to disruption in the feedstock availability or other unforeseeable reasons. In this case, the system will have to use natural gas purchased from utility company to provide any unmet fuel demand by the fuel cell [14].
- iv. The product gas from the PSA unit is expected to have an average heat content of 37 MJ/m³ [15]. The process and flow during the biogas treatment is depicted in Fig. 2 [1, 3].

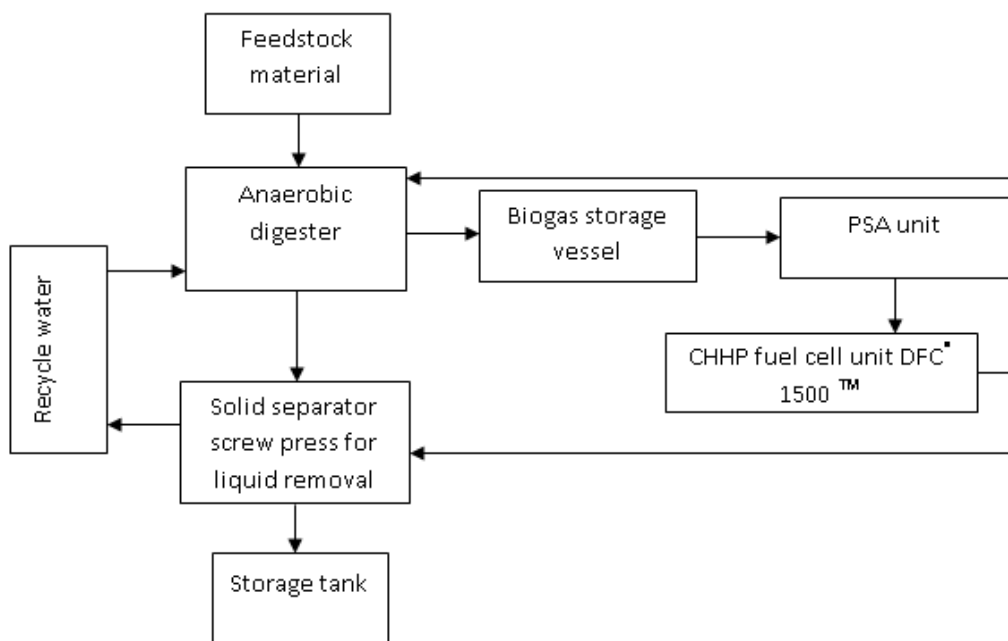

Figure 1. Flow diagram for digester and biogas production

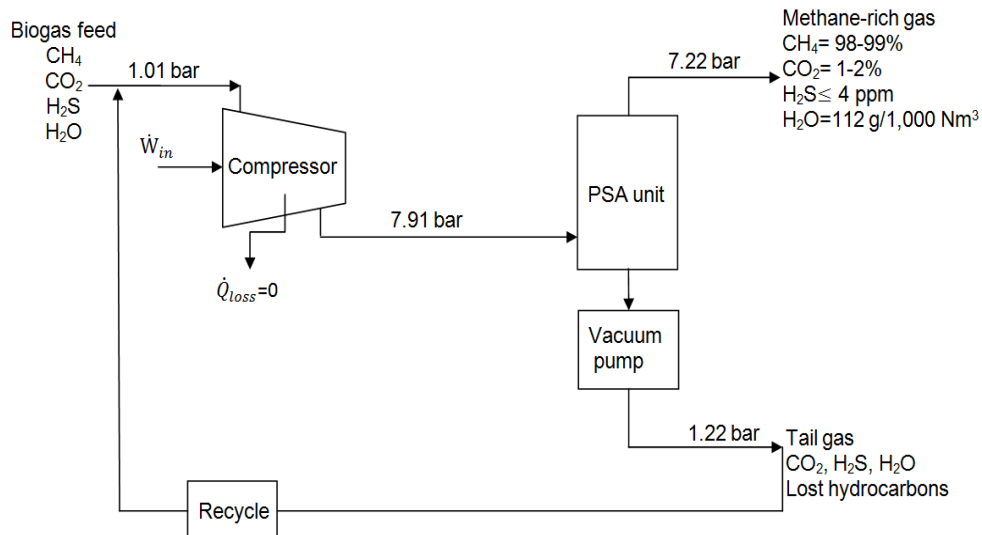

Figure 2. Flow balance diagram

3.3. DFC1500™ FUELCELL POWER PLANT

The anaerobic digester system will be able to supply 90% of fuel for the DFC1500™ unit from locally available feedstock. The remaining 10% fuel required will be purchased from the utility company. In order to accommodate the fluctuations in gas quality, the natural gas used in the design is assumed to contain 98% methane and 2% carbon dioxide (with an average heating value of 37 MJ/m³). Figure 3 shows the reactions taking place inside the fuel cell [1-3, 7].

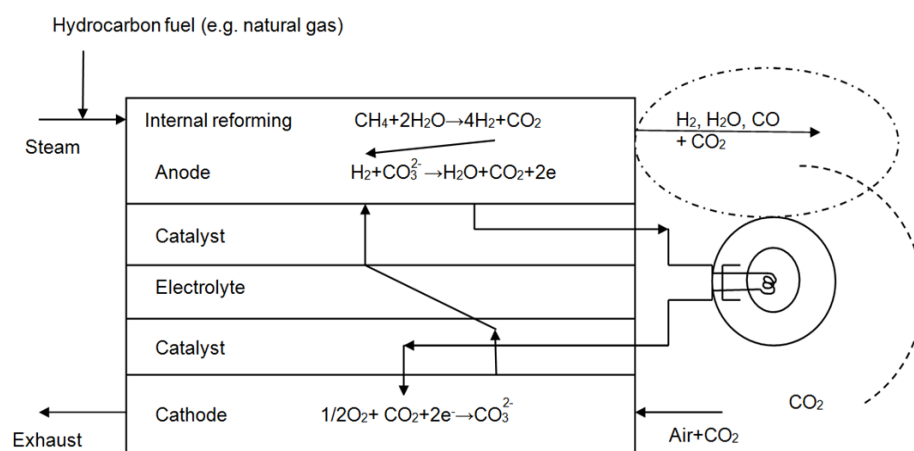

Figure 3. Internal reforming DFC[®] technology

3.3.1. AOG Calculations. The anode outlet gas calculations are made based on the AOG composition calculation document provided by FuelCell Energy [16]. It is assumed that all methane entering the DFC[®] unit is internally reformed and converted to hydrogen and that only 65% (the fuel utilization rate) of the H₂ produced is reacted at the anode to produce electricity. In order to reflect the AOG composition, it is assumed that one third of the 35% hydrogen produced is back-shifted to produce H₂O and CO. Based on these assumptions and the processes taking place inside the fuel cell, the following equations (1 – 5) for every one mole of methane (CH₄) entering the anode side are obtained.

Internal reforming:



Assuming one mole of CH_4 is fed to the DFC[®] system; four moles of hydrogen will be produced. But, only 65% of the hydrogen (i.e. 2.6 moles) reacts at the anode and will result in the following equation.

Corresponding reaction at anode:

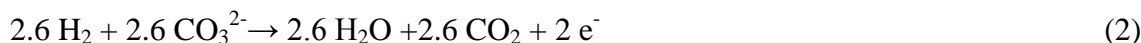

The remaining 35% of the H_2 (1.4 moles) and the entire CO_2 (1 mole) from equation (1) goes directly to the AOG. Combining the products from (2) and 1.4 moles of H_2 and 1 mole of CO_2 from (1) results in the following AOG composition.



But in reality, another internal reaction takes place in the DFC[®] fuel cell. One third of the H_2 in equation (3) (i.e. 0.47 moles) needs to be back-shifted to H_2O and CO resulting in equation (4).



Combining equations (3) and (4) yields the following products:

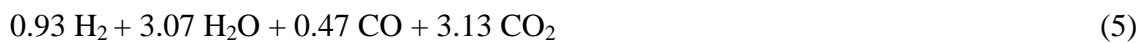

Hence for every one mole of CH_4 the following AOG composition is obtained as on a molar percentage basis H_2O , CO_2 , CO , and H_2 are 40.4, 41.2, 6.2, and 12.2 respectively with assuming 100% CH_4 . The inlet fuel requirement of the DFC1500[™] unit based on 37 MJ/m^3 input fuel is calculated and found to be $286 \text{ m}^3/\text{h}$ consists of 198 moles of CH_4 and 4 moles of CO_2 . The actual AOG flowrate of methane (mol/min) for H_2 , H_2O , CO , and CO_2 is calculated using equation (5) are 156.5, 516.8, 79.1 and 526.9 respectively.

3.3.2. Hydrogen Recovery and Cleaning System. In order to achieve a CHHP system, hydrogen from the AOG must be recovered, cleaned and distributed from the DFC[®] fuel cell system. The details of the hydrogen recovery and purification process are shown in Fig. 4[1-3].

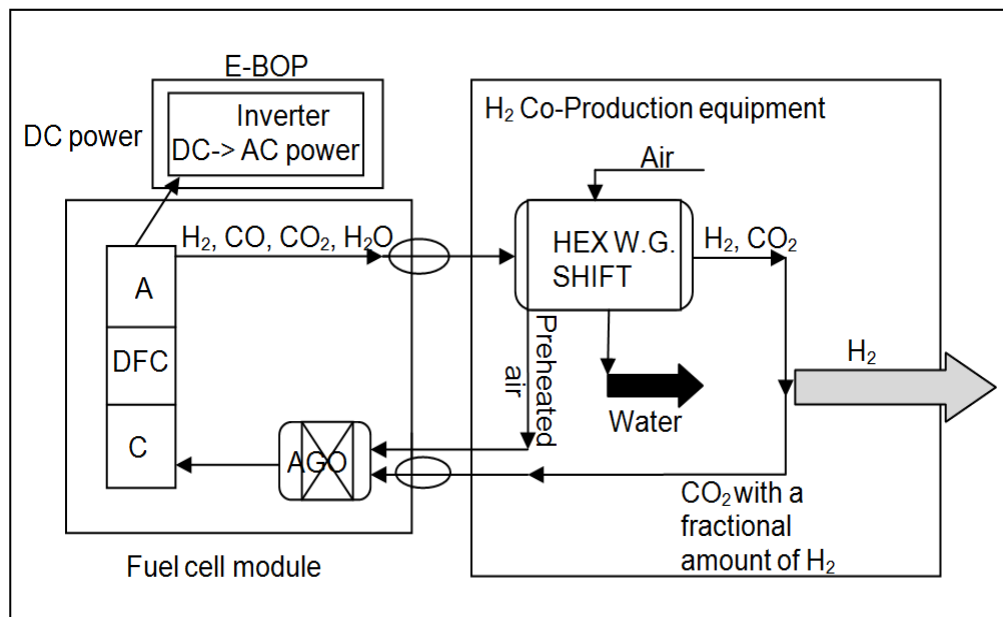

Figure 4. Hydrogen recovery and purification

The AOG outlet pressure is 1.08 bar and outlet temperature to be 600 °C. The AOG is first cooled and pressurized to undergo water-gas shift reaction.

Water-gas shift reaction:



The entire CO present in the AOG reacts with H₂O to produce an additional 242 kg of H₂ and of 4×10³ kg of CO₂ per day. The water vapor is condensed and recycled to the anode side of the fuel cell for the internal reforming of methane. The amount of water produced during condensation is greater than the fuel cell requirement with the excess water is sent into the sewer. The CO₂ and H₂ coming out of the water-gas shift reactor is cooled and separated using a PSA unit. The hydrogen coming out of the PSA unit is compressed and used for different applications on the university campus. Outside air is preheated using the heat exchanger and is mixed with the CO₂ coming out the PSA unit in AGO. The mixture is then transferred to the cathode to complete the cathode reaction as shown in equation (7).

Reaction at cathode:



The flow rates of gases (mol/min) at HEX W.G. shift inlet for H₂, CO₂, H₂O, and CO are 156.5, 526.9, 516.8, and 79.1 while at HEX W.G. shift outlet 235.6, 606, 437.7 and 0.0 respectively. The amount of H₂ and CO₂ flow rate from PSA product outlet gas and tail gas are 212, 0.0, 23.6 and 606 respectively and of H₂ and N₂ at AGO inlet and cathode exhaust are 23.6, 23.6, 1140, and 1140 respectively. Moreover, the flow rates for CO₂ and O₂ at AGO inlet and cathode exhaust are 606, 181.8, 303 and 90.9 respectively. These flow rates are necessary to calculate the amount of hydrogen generated, amount of outside air needed, and amount of exhaust gas. The following assumptions were made during the calculations: (i) H₂ recovery rate from PSA unit is 90%; (ii) N₂ is inert and does not take part in the cathode reactions; (iii) amount of outside air was calculated based on the amount of CO₂ present on the PSA tail gas; (vi) only 70% of CO₂ undergoes reaction to maintain the CO₃²⁻ equilibrium inside the fuel cell. Based on the hydrogen flow rate from the PSA product outlet, the amount of hydrogen generated per day is approximately 650 kg. [7, 17]

3.4. HYDROGEN COMPRESSION, STORAGE, DISPENSING /DISTRIBUTION SYSTEM

The design will incorporate the system into the existing hydrogen infrastructure on the university campus. The existing hydrogen station was designed such that it could handle higher volume of hydrogen in the future. Currently, the hydrogen fueling station at the E3 Commons area has an electrolyzer capable of producing 4.2 kg of hydrogen per day, cascade storage tanks that can hold 33 kg of hydrogen at 450 bar, a hydrogen compressor capable of compressing 15 kg of hydrogen per day to 415 bar, and a 350 bar hydrogen dispenser. The product hydrogen from the PSA unit will be transferred into the buffer tank located in the adjacent hydrogen station via pipeline. The buffer tank feeds two compressors; (i) the existing Hydro-Pac C06-10-70/140LX compressor (415 bar) and (ii) the PDC machines (PDC-13-1000-3000) compressor (250 bar). The compressed hydrogen from the Hydro-Pac compressor will be stored in existing storage tanks. Hydrogen from the PDC machine compressor will be used to fill a hydrogen tube trailer and K-cylinder manifold. The end use of hydrogen is discussed in the next section. The entire process of hydrogen compression, storage, dispensing and distribution is shown in Fig. 5 [1, 2].

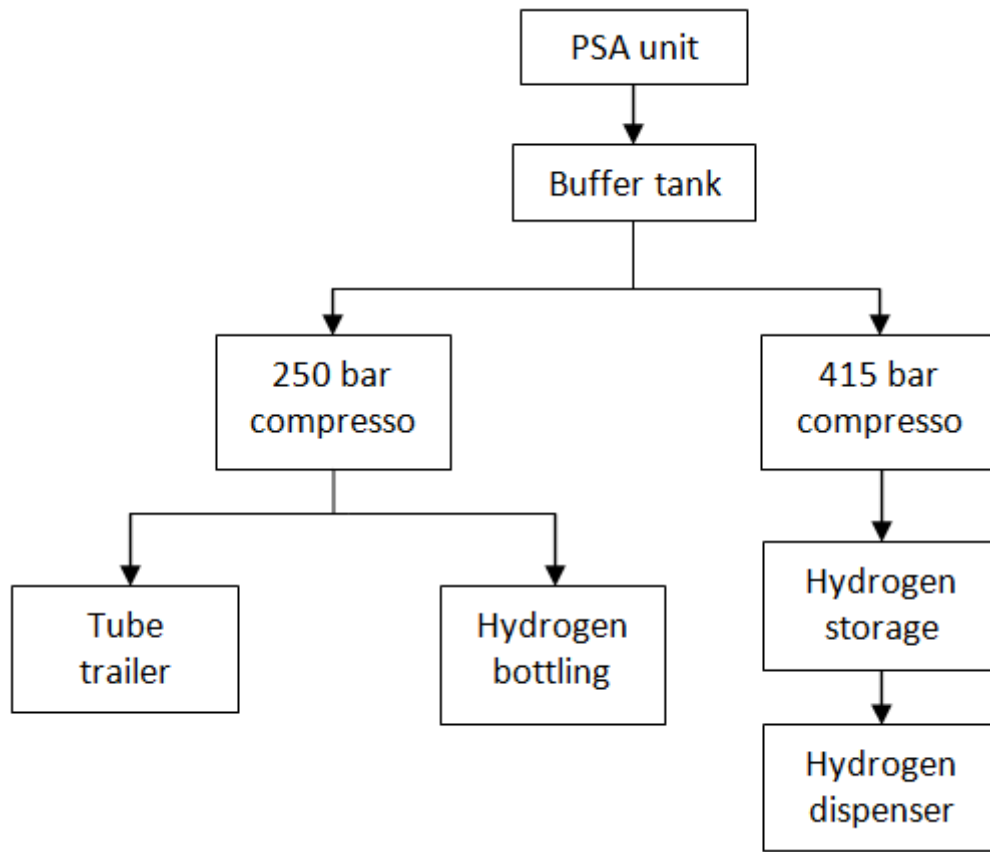

Figure 5. Hydrogen compression, storage, and dispensing

4. RESULTS AND DISCUSSION

4.1. HYDROGEN END-USES

The hydrogen usage (kg/day) on the university campus including personal transportation applications, backup power applications, portable power applications, and other mobility applications are 56, 16, 29, 17, and 5 respectively. The different applications, potential users, and total hydrogen usage per day (123 kg/day) are shown in Fig. 6.

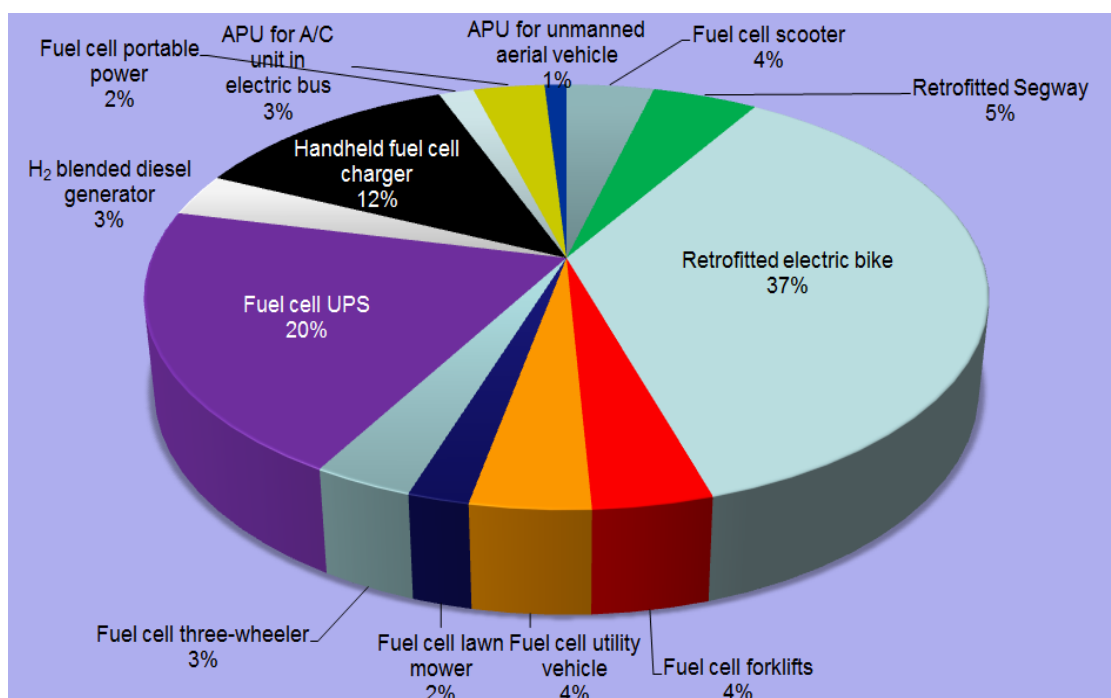

Figure 6. Percentage daily range hydrogen application and usage on the university campus

The major use of the hydrogen on the university campus is for fueling personal transporters. They include fuel cell scooters, Segways and electric bikes retrofitted with fuel cells. The Segways and electric bikes will be retrofitted in-house at the hydrogen research and development garage. The retrofitted Segways and bikes will have fuel cells that act as range extenders for the on-board batteries and will recharge it when the state

of charge falls below a certain set value. The design also incorporates different hydrogen mobility applications for the university campus.

Providing reliable and high quality power to the IT department is vital. Therefore, the design includes a fuel cell UPS unit in the design. It consists of three 8 kW PEM fuel cells and is designed specifically for larger communications backup power loads within the wireless and wireline telecommunications. These units are outdoor units and have a cabinet to accommodate the hydrogen storage cylinders. Another innovative idea used is the blending of hydrogen with diesel while running backup diesel generators. Blending small percentage of hydrogen with diesel fuel has shown to reduce the total fuel consumption of the generator and reduced emissions

5. CONCLUSION

In this paper, we have discussed the Hydrogen production, recovery, cleaning, and End-Uses on the university campus from CHHP system by using local resources. Following the resource assessment study, the team selects FuelCell Energy DFC1500TM unit for its fuel cell. The CHHP system provides hydrogen for transportation, back-up power and other needs. In conclusion, The CHHP system will be able to provide 650 kg of hydrogen to the university campus per day and reduce energy consumption, fossil fuel usage and GHG emissions at the Missouri S&T campus.

ACKNOWLEDGMENTS

The authors wish to acknowledge the Hydrogen Education Foundation for their support of the annual Hydrogen Student Design Contest which challenges university students to design hydrogen energy applications for real-world use.

APPENDIX A. SUPPLEMENTAL DATA

The full report submission for the Hydrogen Education Foundation's Hydrogen Student Design Contest is available online: <http://hydrogencontest.org/previous.asp>.

REFERNCES

- [1] Hamad TA, Agll AA, Hamad YM, Bapat S, Thomas M, Martin KB, et al, "Hydrogen recovery, cleaning, compression, storage, dispensing, distribution system and End-Uses on the university campus from combined heat, hydrogen and power system," *Journal of Int J Hydrogen Energy*, Vol. 39,Pp. 647-653, (2014).
- [2] Hamad TA, Agll AA, Hamad YM, Bapat S, Thomas M, Martin KB, et al, "Study of a molten carbonate fuel cell combined heat, hydrogen and power system: End-use application," *Journal of Case Studies in Thermal Engineering*, Vol. 1,Pp. 45-50, (2013).
- [3] Hamad TA, Agll AA, Hamad YM, Bapat S, Thomas M, Martin KB, et al, "Study of combined heat, hydrogen and power system based on a molten carbonate fuel cell fed by biogas produced by anaerobic digestion," *Journal of Energy Conversion and Management*, Vol. 81,Pp. 184-191, (2014).
- [4] Yu M , Muy S, Quader F, Bonifacio A,Varghese R , Clerigo E, et al, "Combined Hydrogen, Heat and Power (CHHP) pilot plant design," *Journal of Int J Hydrogen Energy*, Vol. 38, No.12, Pp. 4881-4888, (2013).
- [5] Braun R J, "Techno-economic optimal design of solid oxide fuel cell systems for micro-combined heat and Power applications in the U.S.," *Journal of J Fuel Cell Sci Technol.*, Vol. 7, No. 3, Pp. 0310181-03101815,(2013).
- [6] Vera D, Jurado F, de Mena B, Schories G, "Comparison between externally fired gas turbine and gasifier-gas turbine system for the olive oil industry," *Journal of Energy*, Vol. 36, No. 12, Pp. 6720-6730,(2011).
- [7] Agll AA, Hamad YM, Hamad TA, Bapat S, Thomas M, Martin KB, et al, "Study of a molten carbonate fuel cell combined heat, hydrogen and power system: Energy analysis," *Journal of App Thermal Eng*, Vol. 59, Pp. 634-638, (2013).
- [8] Hamad YM, Hamad TA, Agll AA, Bapat S, Thomas M, Martin KB, et al, "Molten Carbonate Fuel Cell Combined Heat, Hydrogen and Power System: Feedstock Analysis," *Journal of Energy Science and Technology*, Vol. 6, No. 2, Pp. 1-5, (2013).
- [9] Weiland P. Biogas production: Current state and perspectives, "Appl Microbiol Biot.," , Vol. 85, No. 4, Pp. 849-860, (2010).
- [10] Krishna R, "Adsorptive separation of CO₂/CH₄/CO gas mixtures at high pressures," *Journal of Micropor Mesopor Mat*, Vol. 156, Pp. 217-223, (2012).

- [11] Rehl T, Müller J. Life cycle assessment of biogas digestate processing technologies. *Resour Conserv Recy.*56 (1) (2011)92–104.
- [12] Locher C, Meyer C, Steinmetz H, “Operating experiences with a molten carbonate fuel cell at stuttgart-möhringen wastewater treatment plant,” *Journal of Water Sci Technol.*, Vol. 65, No.5, Pp. 789-794, (2012).
- [13] Rasi S, Läntelä J. Veijanen A, Rintala J, “Landfill gas upgrading with countercurrent water wash,” *Journal of Waste Manage*, Vol. 28, No. 9, Pp. 1528-1534, (2012).
- [14] Rapport JL, Zhang R, Jenkins BM, Hartsough BR, Tomich TP, “Modeling the performance of the anaerobic phased solids digester system for biogas energy production,” *Journal of Biomass Bioenerg*, Vol. 35, No. 3, Pp. 1263-1272, (2011).
- [15] Kamarudin SK, Daud WRW, Som AM, Mohammad AW, Takriff S, Masdar MS. “The conceptual design of a PEMFC system via simulation,” *Journal of Chem Eng J*, Vol. 103, No. 1-3, Pp. 99-113, (2004).
- [16] <http://hydrogencontest.org/pdf/AOG%20Composition%20Example.pdf>. Anode Outlet Gas Composition Calculation Example.
- [17] Oller I, Malato S, Sánchez-Pérez JA, “Combination of Advanced Oxidation Processes and biological treatments for wastewater decontamination,” *Journal of Sci Total Environ.*, Vol. 409, Pp. 4141-4166,(2011).

V STUDY OF A MOLTEN CARBONATE FUEL CELL COMBINED HEAT, HYDROGEN AND POWER SYSTEM: END-USE APPLICATION

Tarek A. Hamad, John W. Sheffield

Department of Mechanical and Aerospace Engineering, Missouri University of Science and Technology, 400 W 13th Street, Rolla, MO 65409-0050, USA

Received 22 August 2013

Received in revised form 5 September 2013

Accepted 5 September 2013

ABSTRACT

To address the problem of fossil fuel usage and high greenhouse gas emissions at the Missouri University of Science and Technology campus, using of alternative fuels and renewable energy sources can lower energy consumption and greenhouse gas emissions. Biogas, produced by anaerobic digestion of wastewater, organic waste, agricultural waste, industrial waste, and animal by-products is a potential source of renewable energy. In this work, we have discussed the design of CHHP system for the campus using local resources. An energy flow and resource availability study is performed to identify the type and source of feedstock required to continuously run the fuel cell system at peak capacity. Following the resource assessment study, the team selects FuelCell Energy DFC1500TM unit as a molten carbonate fuel cell. The CHHP system provides electricity to power the university campus, thermal energy for heating the anaerobic digester, and hydrogen for transportation, back-up power and other needs. In conclusion, the CHHP system will be able to reduce fossil fuel usage, and greenhouse gas emissions at the university campus.

Keywords: CHHP system, A molten carbonate, Anaerobic digestion, Renewable energy.

1. INTRODUCTION

The Missouri University of Science and Technology (Missouri S&T) campus in Rolla, Missouri, USA is a relatively small campus with 1.15 km² and approximately 6,500 students on campus. The university is one of the City of Rolla's largest electric power consumers with a peak demand of 6.36 MWe and annual electric energy consumption of 2.55×10^6 kWh/yr. Currently, electrical power for the university campus is purchased from RMU and distributed from the substation and switchgear located at the campus power plant. In addition, the university thermal power plant generates electricity with a back pressure steam turbine, accounting for an additional 10% of electricity. Biogas produced by anaerobic digestion of wastewater, organic waste, agricultural waste, and industrial waste is a potential source of renewable energy. Treated biogas can be used to generate CHHP using a molten carbonate fuel cell. The power generated by the CHHP system is used at various locations on the campus to reduce the total electric power purchased and minimize air pollution [1–3]. In addition, the CHHP system has higher efficiency than other distributed generation plants of similar size [4, 5]. The hydrogen generated is used to power different applications on the university campus including personal transportation [6, 7]. The research presented in this paper was performed as part of the 2012 Hydrogen Student Design Contest. The contest rules specified the use of FuelCell Energy fuel cell and biogas with 60% methane and 40% carbon dioxide concentration. An energy flow and resource availability study was performed to identify the type and source of feedstock required to continuously run the CHHP system to produce maximum capacity of electricity, heat recovery and hydrogen [8].

2. RESOURCE ASSESSMENT

2.1. FEEDSTOCK SOURCE IDENTIFICATION

During the assessment, “locally available feedstock” was defined as one which is within 20 km of Rolla. The largest source of locally available feedstock is MSW averaging 60 tons/day. Of this, approximately 33% is organic waste including 17% food waste. The campus plans to partner with the City of Rolla and will start an “Organic Waste Collection Program” to collect organic waste. Food waste collected daily is mixed with the trash and the sanitary sewer and is connected to the city’s main sewer lines.

3. EXPERIMENTAL PROCEDURE

3.1. CHHP SYSTEM TECHNICAL DESIGN

The design discussed in this paper has three major systems: (i) anaerobic digestion system, (ii) CHHP system consisting of a DFC1500TM fuel cell unit, and (iii) hydrogen compression, storage, and dispensing system [8]. These systems were designed based on the results from the feedstock assessment and the biogas production from local resources. It was found that the anticipated methane production after biogas treatment is 260 m³/h with a heat content of 156 MJ/m³.

The anaerobic digestion system and the CHHP system are sized based on the amount of locally available feedstock and the amount of methane gas generated respectively [9]. The hydrogen recovery, purification, compression, storage, and distribution system are designed based on the hydrogen demand on the university campus and the 65% fuel utilization rate [10, 11].

3.2. ANAEROBIC DIGESTION, GAS TREATMENT SYSTEM AND FUEL STORAGE

Digester and biogas production are shown in Fig. 1. [9] The feedstock from the cement storage bin is transported via a screw feeder to a hygienisation unit where it is heated to 70° C for one hour to remove all the pathogens [12]. After heating, the feedstock is transported to a 45.4 m³ equalization tank where the biomass is mixed to form a homogenous mixture before being fed into the digester [13]. Biogas from the anaerobic digestion is stored in a buffer tank which supplies biogas to the gas treatment system. The treatment system uses pressure swing adsorption (PSA) technology to separate methane present in the biogas [14- 18].

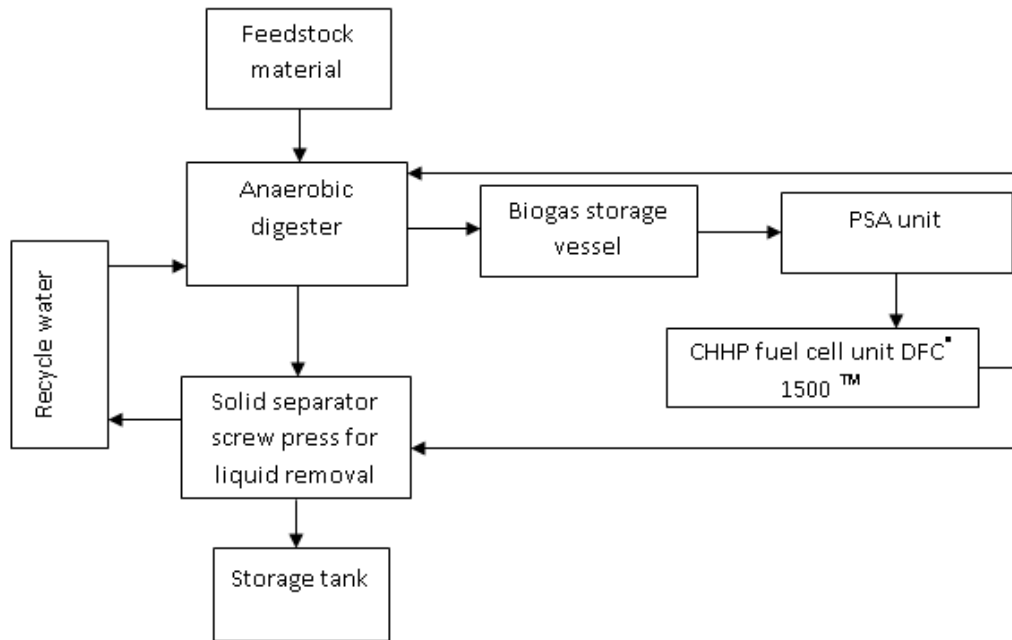

Figure 1. Flow diagram for digester and biogas production

3.3. DFC1500™ FUELCELL POWER PLANT

The anaerobic digester system will be able to supply 90% of fuel for the DFC1500™ unit from locally available feedstock. The remaining 10% fuel required will be purchased from the utility company. In order to accommodate the fluctuations in gas quality, the natural gas used in the design contains 98% methane and 2% carbon dioxide (with an average heating value of 156 MJ/m³). Figure 2 shows the reactions taking place inside the fuel cell

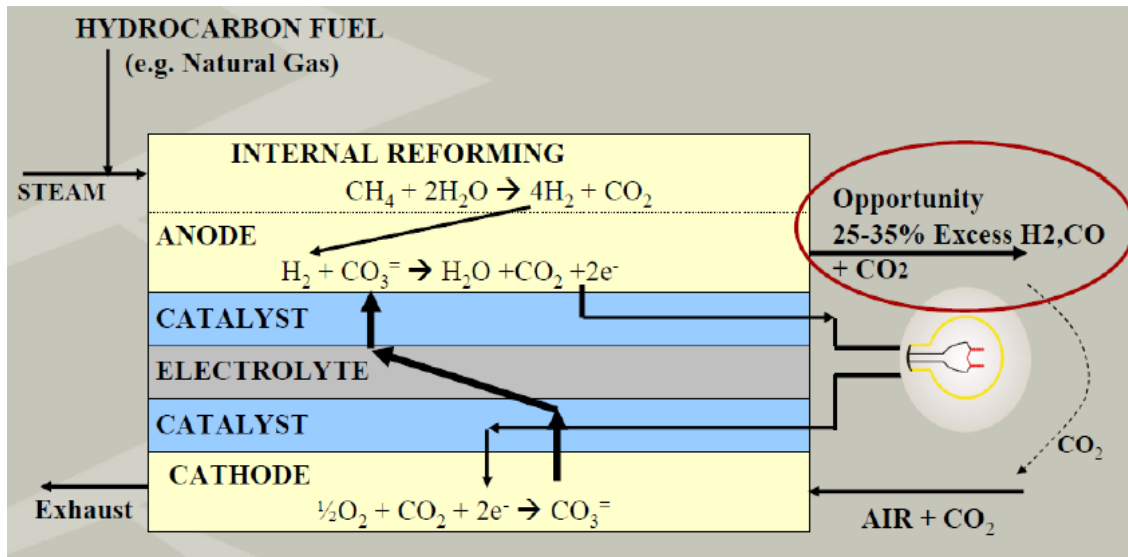

Figure 2. Internal reforming DFC[®] technology

3.3.1. AOG Calculations. The anode outlet gas calculations are made based on the AOG composition calculation document provided by FuelCell Energy [19]. The following equations (1 – 5).



Assuming one mole of CH_4 is fed to the DFC[®] system; only 65% of the hydrogen (i.e. 2.6 moles) reacts at the anode and will result in the following equation.

Corresponding reaction at anode:

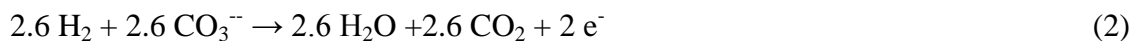

The remaining 35% of the H_2 (1.4 moles) and the entire CO_2 (1 mole) from equation (1) goes directly to the AOG. Combining the products from (2) and 1.4 moles of H_2 and 1 mole of CO_2 from (1) results in the following AOG composition.



But in reality, another internal reaction takes place in the DFC[®] fuel cell. One third of the H_2 in equation (3) (i.e. 0.47 moles) needs to back-shifted to H_2O and CO resulting in equation (4).

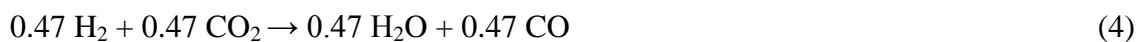

Combining equations (3) and (4) yields the following products:

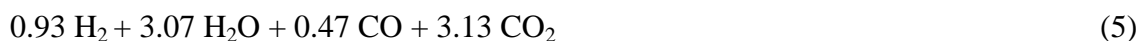

Hence for every one mole of CH_4 the following AOG composition is obtained as on a molar percentage basis H_2O , CO_2 , CO , and H_2 are 40.4, 41.2, 6.2, and 12.2 respectively with assuming 100% CH_4 . The inlet fuel requirement of the DFC1500TM unit based on 156 MJ/m^3 input fuel is calculated and found to be $286 \text{ m}^3/\text{h}$ consists of 198 moles of CH_4 and 4 moles of CO_2 . The actual AOG flowrate of methane (mol/min) for H_2 , H_2O , CO , and CO_2 is calculated using equation (5) are 156.5, 516.8, 79.1 and 526.9 respectively.

3.3.2. Hydrogen Recovery and Cleaning System. In order to achieve a CHHP system, hydrogen from the AOG must be recovered, cleaned and distributed. The details of the hydrogen recovery and purification process are shown in Fig. 3.

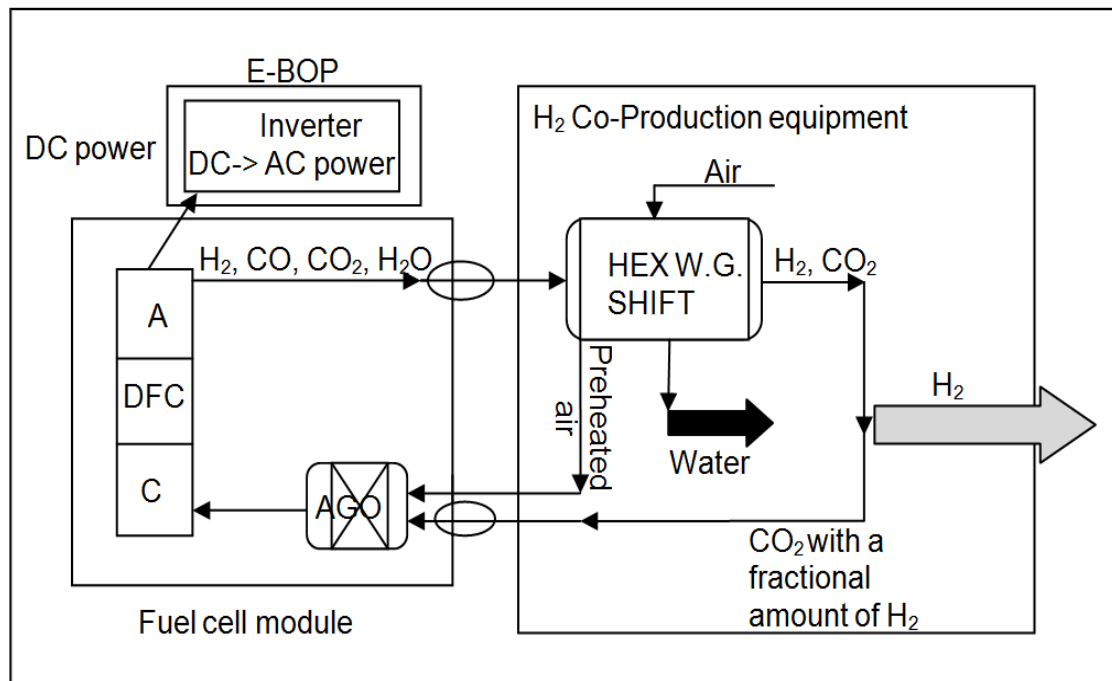

Figure 3. Hydrogen recovery and purification

The AOG outlet pressure is 1.08 bar and outlet temperature to be 600°C .



The entire CO present in the AOG reacts with H₂O to produce an additional 242 kg of H₂ and of 4×10³ kg of CO₂ per day. The water vapor is condensed and recycled to the anode side of the fuel cell for the internal reforming of methane. The amount of water produced during condensation is greater than the fuel cell requirement with the excess water is sent into the sewer. The CO₂ and H₂ coming out of the water-gas shift reactor is cooled and separated using a PSA unit. The hydrogen coming out of the PSA unit is compressed and used for different applications on the university campus. Outside air is preheated using the heat exchanger and is mixed with the CO₂ coming out the PSA unit in AGO. The mixture is then transferred to the cathode to complete the cathode reaction as shown in equation (7).



The flow rates of gases at different stages were tabulated in Table 1. These flow rates are necessary to calculate the amount of hydrogen generated, amount of outside air needed, and amount of exhaust gas. The amount of hydrogen generated per day is 650 kg.

Table 1. Flow of gases at different sections of the system

Gas	HEX W.G. shift inlet (mol/min)	HEX W.G. shift outlet (mol/min)	PSA product outlet (mol/min)	PSA tail gas (mol/min)	AGO inlet (mol/min)	cathode exhaust (mol/min)
H ₂	156.5	235.6	212	23.6	23.6	23.6
CO ₂	526.9	606	-	606	606	181.8
H ₂ O	516.8	437.7	-	-	-	-
CO	79.1	-	-	-	-	-
O ₂	-	-	-	-	303	90.9
N ₂	-	-	-	-	1,140	1,140

3.4. HYDROGEN COMPRESSION, STORAGE, DISPENSING /DISTRIBUTION SYSTEM

The system will be incorporated into the existing hydrogen infrastructure on the university campus. The existing hydrogen station was designed such that it could handle higher volume of hydrogen in the future. The product hydrogen from the PSA unit will be transferred into the buffer tank located in the adjacent hydrogen station via pipeline. The buffer tank feeds two compressors; (i) the existing Hydro-Pac C06-10-70/140LX compressor (415 bar) and (ii) the PDC machines (PDC-13-1000-3000) compressor (250 bar). The compressed hydrogen from the Hydro-Pac compressor will be stored in existing storage tanks. Hydrogen from the PDC machine compressor will be used to fill a hydrogen tube trailer and K-cylinder manifold. The entire process of hydrogen compression, storage, dispensing and distribution is shown in Fig. 4.

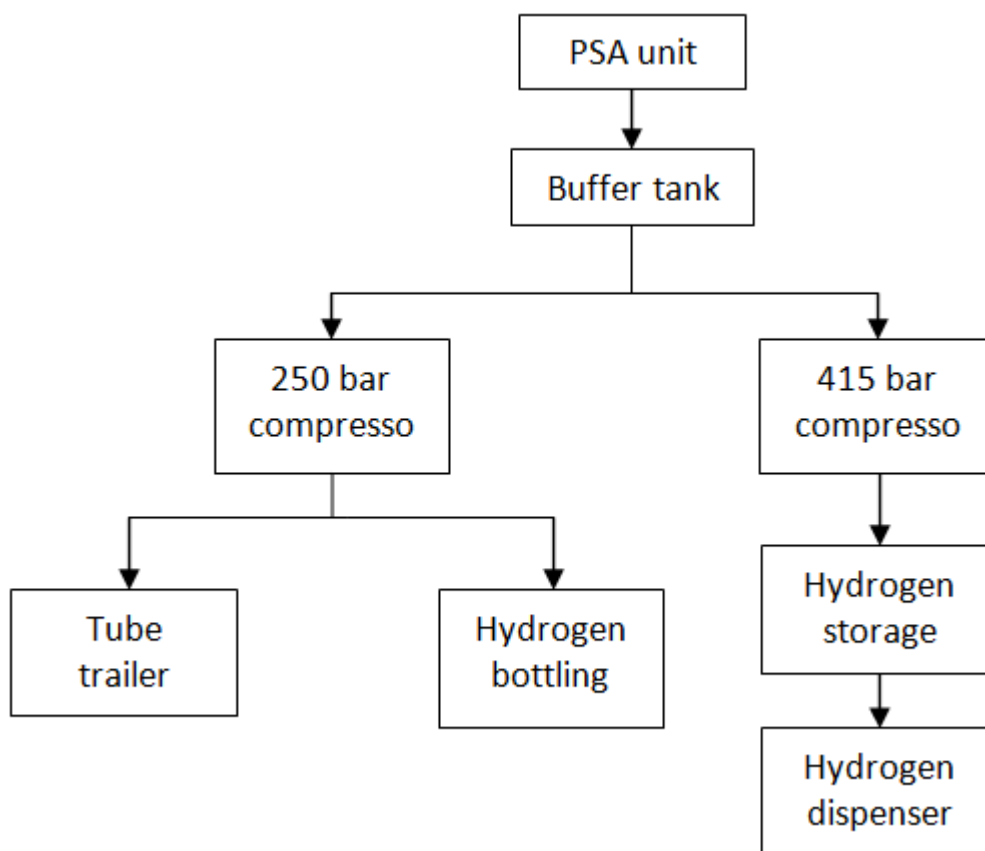

Figure 4. Hydrogen compression, storage, and dispensing

4. RESULTS AND DISCUSSION

4.1. ELECTRICITY USE

The electric power output of the DFC1500TM unit operating in the simple cycle CHP mode is 1.4 MW_e. This corresponds to the net power after providing the parasitic loads for its MBOP and energy loss in the E-BOP. However, there are additional components that require electric power for the DFC1500TM unit operating in CHHP mode. These components, including the heat exchanger for anode outlet gas cooling, the water-gas shift reactor, and the PSA unit for hydrogen purification and operate collectively with the fuel cell unit to form the CHHP system. Based on the power requirements of these components, the net power output from the CHHP system was 1.1 MWe. The total electric power requirement of different equipment used in the design is tabulated in Table 2.

The total net energy production from the CHHP system is 26.4×10^3 kWh per day and the energy demand for on-site use is 4,548 kWh per day. Hence, the CHHP system will be able to provide 22×10^3 kWh per day to the university campus. This corresponds to 27% of the whole campus electricity requirement.

Table 2. Power demand and energy consumption

Equipment	Max. power rating (kW _e)	Daily operation time (h)	Daily energy consumption (kWh)
Feedstock storage facility	5	12	60
Macerator	15	4	60
Screw feeder	5	4	20
Pump	75	4	300
Hygienization unit	2	4	8
Anaerobic digester	5	24	120
Storage tank	5	24	120
Biogas PSA unit	40	24	960
Hydrogen Comp1	7.5	24	180
Hydrogen Comp2	100	24	2.4×10 ³
Auxiliary loads	20	16	320
Total	279.5	164	4,584

4.2. THERMAL AND HYDROGEN USE

The DFC1500TM unit has 4 GJ/h at 322° K available for heat recovery while operating in CHP mode. The thermal energy available for heat recovery was calculated based on the cathode exhaust gas composition in Table 1 and equation (8) and is shown in Table 3. The temperature difference of the input and output temperature of the heat recovery system is 320° K [20].

$$Q = m \times C_p (\Delta T) \quad (8)$$

Where: m , C_p and ΔT are the mass flow rate of the gas (kg/h), the specific heat of the gas (kJ/kgK) and the change in temperature of the gas (K) respectively.

Table 3. Thermal energy available for heat recovery from the DFC1500™ CHHP system

Gas	Cathode exhaust (kmol/min)	Mass flow rate (kg/h)	Cp (kJ/kgK)	ΔT (K)	Q flow rate (MJ/h)
H ₂	0.024	2.85	14.32	322	13.1
CO ₂	0.18	196.5	0.84	322	53.4
O ₂	0.91	152.79	0.92	322	45.2
N ₂	1.14	2,188.28	1.04	322	732.8
Total		2,540			844.6

The hydrogen usage (kg/day) on the university campus including personal transportation applications, backup power applications, portable power applications, and other mobility applications are 56, 16, 29, 17, and 5 respectively. The different applications, potential users, and total hydrogen usage per day (123 kg/day) are shown in Fig. 5.

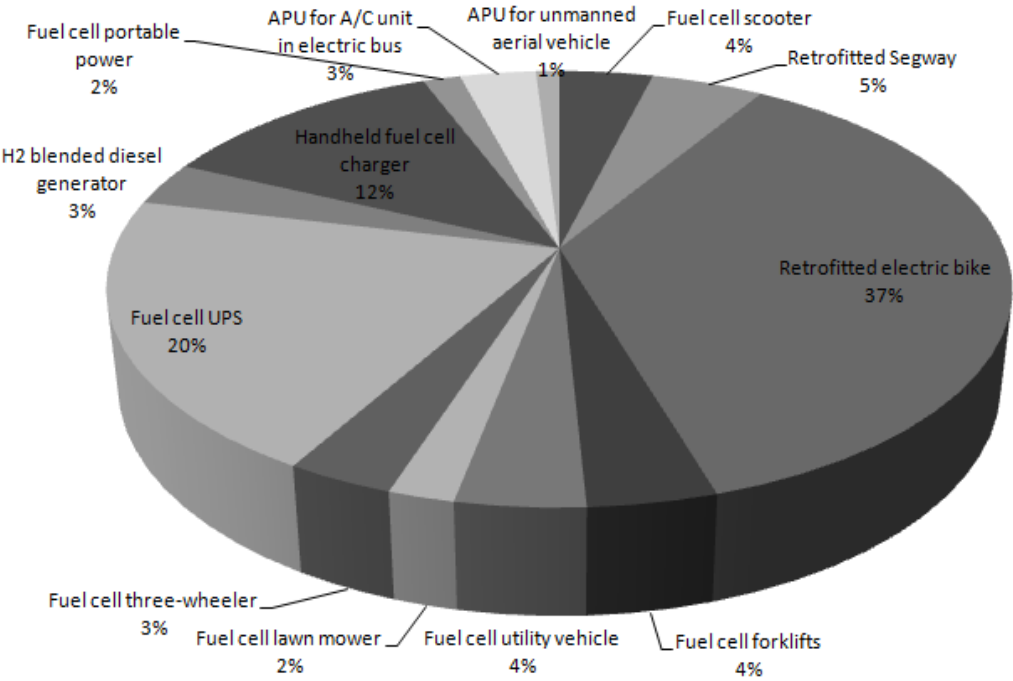

Figure 5. Hydrogen application and usage on the university campus

5. CONCLUSION

In this paper, we have discussed the design of a CHHP system for the Missouri S&T campus using local resources. Following the resource assessment study, the team selects FuelCell Energy DFC1500TM unit for its fuel cell. The CHHP system provides electricity to power the university campus, thermal energy for heating the anaerobic digester, and hydrogen for transportation, back-up power and other needs. The CHHP system will be able to provide approximately 22,000 kWh and 650 kg of hydrogen to the university campus per day. In conclusion, the CHHP system will reduce energy consumption, fossil fuel usage, and greenhouse gas (GHG) emissions at the Missouri S&T campus. It will be able to provide approximately 27% of the university campus' electricity need.

ACKNOWLEDGMENTS

The authors wish to acknowledge the Hydrogen Education Foundation for their support of the annual Hydrogen Student Design Contest which challenges university students to design hydrogen energy applications for real-world use.

REFERNCES

- [1] Abbasi T, Tauseef, SM, Abbasi SA, “Anaerobic digestion for global warming control and energy generation - An overview,” *Journal of Renew Sust Energ Rev.*, Vol. 16, Pp. 3228-3242, (2012).
- [2] Nasir IM, Mohd Ghazi TI, Omar R, “Anaerobic digestion technology in livestock manure treatment for biogas production: A review,” *Journal of Eng. in Life Sci.*, Vol. 12, Pp. 258-269, (2012).
- [3] Shoko E, McLellan B, Dicks AL, da Costa JCD, “Hydrogen from coal: Production and utilisation technologies,” *Journal of Int J Coal Geol*, Vol. 65, Pp. 213-222, (2006).
- [4] Braun R J, “Techno-economic optimal design of solid oxide fuel cell systems for micro-combined heat and Power applications in the U.S.,” *Journal of J Fuel Cell Sci Technol.*, Vol. 7, No. 3, Pp. 0310181-03101815,(2013).
- [5] Vera D, Jurado F, de Mena B, Schories G, “Comparison between externally fired gas turbine and gasifier-gas turbine system for the olive oil industry,” *Journal of Energy*, Vol. 36, No. 12, Pp. 6720-6730,(2011).
- [6] Oller I, Malato S, Sánchez-Pérez JA, “Combination of Advanced Oxidation Processes and biological treatments for wastewater decontamination,” *Journal of Sci Total Environ.*, Vol. 409, Pp. 4141-4166,(2011).
- [7] Pronto JL, Gooch CA, “Greenhouse gas emission reductions for seven on-farm dairy manure-based anaerobic digestion systems - Final results,” *Journal of ASABE*, Vol. 7, Pp. 35-42, (2010).
- [8] Yu M , Muy S, Quader F, Bonifacio A, Varghese R , Clerigo E, et al, “Combined Hydrogen, Heat and Power (CHHP) pilot plant design,” *Journal of Int J Hydrogen Energy*, Vol. 38, No.12, Pp. 4881-4888,(2013).
- [9] Weiland P. “Biogas production: Current state and perspectives,” *Journal of Appl Microbiol Biot*, Vol. 85, No. 4, Pp. 849-860, (2010).
- [10] Ward, A. J., Hobbs, P. J., Holliman, P. J., & Jones, D. L, “Optimisation of the anaerobic digestion of agricultural resources,” *Journal of Bioresource Technol*, Vol. 99, No. 17, Pp. 7928-7940, (2008).
- [11] Huang W, Zhang Y, “Energy efficiency analysis: Biomass-to-wheel efficiency related with biofuels production, fuel distribution, and powertrain systems,” *Journal of PLoS ONE*, Vol. 6, No. 7, Pp. 7, (2011).

- [12] Karellas S, Boukis I, Kontopoulos G, "Development of an investment decision tool for biogas production from agricultural waste," *Journal of Renew Sust Energ Rev*, Vol. 14, No. 4, Pp. 1273-1282, (2010).
- [13] Zingoni A, "Shell forms for egg-shaped concrete sludge digesters: A comparative study on structural efficiency," *Journal of Struct Eng Mech*, Vol. 19, No. 3, Pp. 321-336, (2010).
- [14] Krishna R, "Adsorptive separation of CO₂/CH₄/CO gas mixtures at high pressures," *Journal of Micropor Mesopor Mat*, Vol. 156, Pp. 217-223, (2012).
- [15] Rittmann BE, Mayer B, Westerhoff P, Edwards M, "Capturing the lost phosphorus," *Journal of Chemosphere*, Vol. 84, No. 6, Pp. 846-853, (2011).
- [16] Locher C, Meyer C, Steinmetz H, "Operating experiences with a molten carbonate fuel cell at stuttgart-möhringen wastewater treatment plant," *Journal of Water Sci Technol*, Vol. 65, No. 5, Pp. 789-794, (2012).
- [17] Köppel, W, "Biogas treatment for SNG production," *Journal of Int Gas Res Conf Proceedings*, Vol. 2, Pp. 1327-1345, (2008).
- [18] Kamarudin SK, Daud WRW, Som AM, Mohammad AW, Takriff S, Masdar MS. "The conceptual design of a PEMFC system via simulation," *Journal of Chem Eng J*, Vol. 103, No. 1-3, Pp. 99-113, (2004).
- [19] <http://hydrogencontest.org/pdf/AOG%20Composition%20Example.pdf> Anode Outlet Gas Composition Calculation Example.
- [20] Agll AA, Hamad YM, Hamad TA, Bapat S, Thomas M, Martin KB, et al, "Study of a molten carbonate fuel cell combined heat, hydrogen and power system: Energy analysis," *Journal of App Thermal Eng*, Vol. 59, Pp. 634-638, (2013).

VI SOLID WASTE AS RENEWABLE SOURCE OF ENERGY: CURRENT AND FUTURE POSSIBILITY IN LIBYA

Tarek A. Hamad, John W. Sheffield

Department of Mechanical and Aerospace Engineering, Missouri University of Science and Technology, 400 W 13th Street, Rolla, MO 65409-0050, USA

Received 14 July

Received in revised form 10 September 2014

Accepted 19 September 2014

ABSTRACT

Solid waste holds the greatest potential as biomass source in Libya. The rapid expansion of industry has led to increased urbanization, and growing population. These factors have dramatically increased the amount of MSW (municipal solid waste) generated in Libya. However, issues related to environmentally sound MSW management – including waste decrease and clearance – have not been addressed sufficiently. This study presents an overview on solid waste that can be used as a source of bioenergy in Libya including MSW, ISW (industrial solid waste), and HSW (health care wastes) as biomass sources. The management of solid waste and valorization is based on an understanding of MSW's composition and physicochemical characteristics. The results show that organic matter represents 59% of waste, followed by paper-cardboard 12%, plastic 8%, miscellaneous 8%, metals 7%, glass 4%, and wood 2%. The technology of WTE (Waste-to-energy) incineration, which recovers energy from discarded MSW and produces electricity and/or steam for heating, is recognized as a renewable source of energy and is playing an increasingly important role in MSW management in Libya. This paper provides an overview of this technology, including both its conversion options and its useful products (e.g., electricity, heat, greenhouse gas emissions). The WTE benefits and the major challenges in expanding WTE incineration in Libya are discussed. It also demonstrates that Libya could become an exporter of hydrogen in lieu of oil and natural gas.

Keywords: Libya, Municipal solid waste, Renewable energy, Waste management, Waste to energy.

1. INTRODUCTION

Libya, located in North Africa between 26 latitude north and 17 longitudes east, extends over 1,759,540 km² [1]. It is bordered by the Mediterranean Sea to the north, Egypt to the east, Sudan to the southeast, Chad and Niger to the south, and Algeria and Tunisia to the west. Both the Mediterranean Sea and the desert affect Libya's weather. In the winter, the weather is cold, with some rain on the coast. The Sahara is very dry and hot in the summer and cold and dry in the winter [1]. Temperatures in the summer can reach 50°C during the day; through they are typically closer to 40°C. The average annual temperature is approximately 20.5°C. The mean annual rainfall varies from 180 mm (in the east) to 90 mm (in the west). Libya's population has nearly doubled over the last 10 years. Libyan youth represent more than 50% of the current population. This situation places a great deal of pressure on energy demands, food supplies, and even the environment by increasing the generation of waste and residues. For the last two decades, Libya had depended on fossil fuels, petroleum, and natural gas for its income, energy, industrialization, and development. Although some efforts have been made to diversify the sources of income, to a large extent, fossil fuels have continued to play a major role in the country's economy. Unfortunately, the fossil fuels available in this area are becoming depleted (Fig. 1). A total dependence on oil and gas can lead to serious consequences [2]. Out of the renewable energy sources, such as solar, wind, and wastes, conversion of waste feedstocks to H₂. Its useful products such as electricity, heat, reduce fossil fuel usage, and greenhouse gas emissions at the Libya. Solar energy stands out as the most promising. Libya experiences, on 3400 h of sunshine per year; it maintains an average insulation of approximately 2200kWh/m² annually (Fig. 2) [2, 3]. More than 80% of the land is unused. This land might not be used for either agriculture or any other foreseeable purpose than solar energy collection. Solid waste is one of most important sources of biomass potential in Libya. Biomass is a by-product from human activities that is characterized by negative impacts that may affect man and the environment when disposed of in an inappropriate way. This paper investigates whether or not solid waste can be used as a source of bioenergy in Libya.

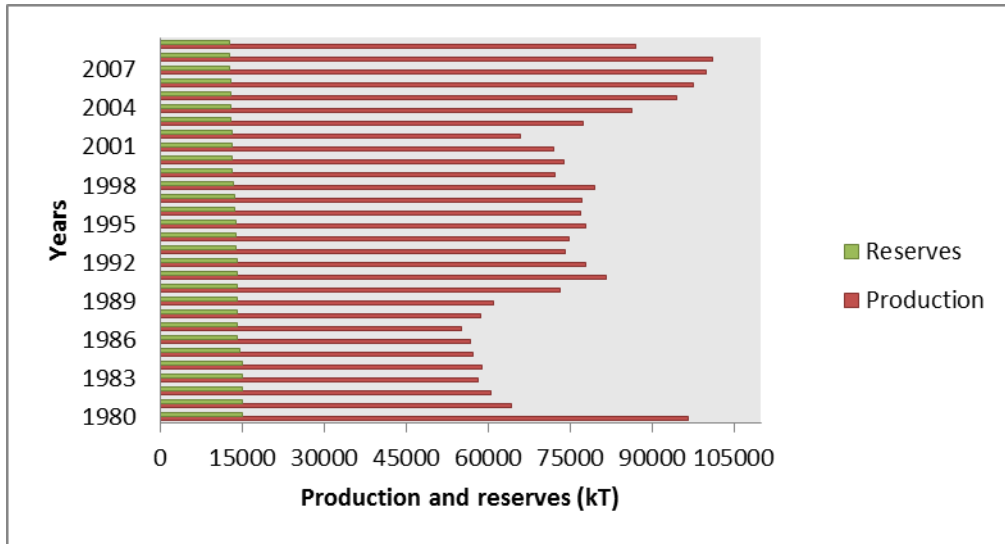

Figure 1. Fossil fuel reserves and production of Libya vs. time

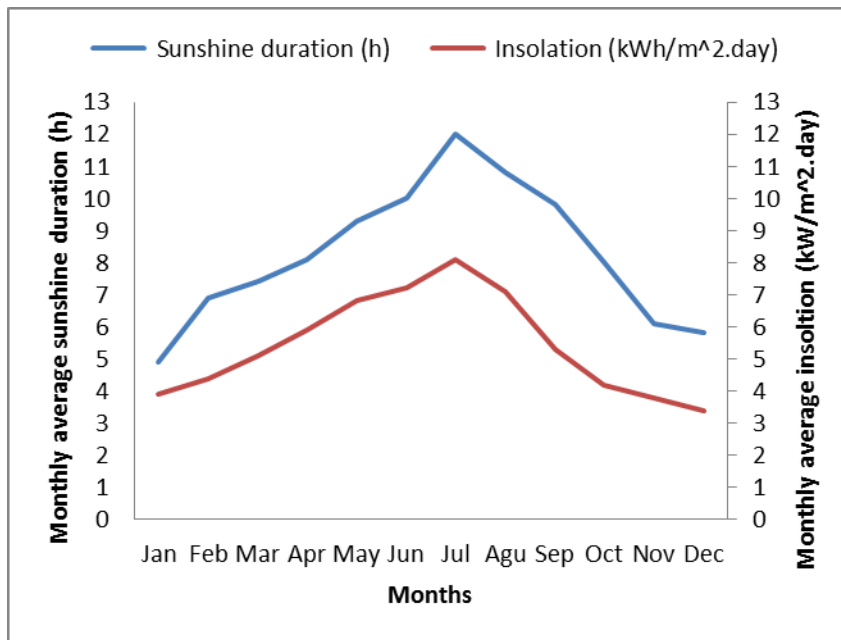

Figure 2. Sunshine duration and insolation for Libya

2. SOLID WASTE GENERATION IN LIBYA

Classifications of solid wastes are proposed here according to the origin wastes: municipal solid waste (MSW), industrial solid waste (ISW), and healthcare solid waste (HSW) [4, 5]. The quantity of MSW generated in Libya is estimated at 3.2 million tons/year (household and similar waste) [6, 7]. The overall generation of ISW, including non-hazardous wastes, industrial wastes, demolition, and construction, is 1,248,000 tons/year [6, 7]. The hazardous waste generated is 106,200 tons/year, HSW reaches 87,000 tons/year [6]. The increase in solid waste production has been attributed to the population growth, the expansion of trade, and the increased industry in Libya.

2.1. MUNICIPAL SOLID WASTE

Municipal solid waste, more commonly known as either trash or garbage consists of everyday items (e. g., product packaging, grass clippings, furniture, clothing, bottles, food scraps, newspapers, appliances, paint, and batteries) that are collected by municipalities or other local authorities [8]. These wastes are generally in either a solid or a semi-solid form. They can be classified as biodegradable wastes that include the following: food and kitchen waste, green waste, and paper (recycled); recyclable materials (e.g., paper, glass, bottles, cans, metals, and certain plastics) inert waste (e.g., construction wastes, demolition wastes, dirt, rocks, and debris); composite wastes (e.g., clothing and tetra packs). Waste plastics (e.g., toys); domestic hazardous wastes (also referred to as household hazardous wastes); and toxic wastes (e.g., medication, e-waste, paints, chemicals, light bulbs, fluorescent tubes, spray cans, fertilizer, pesticide containers, and shoe polish). Libya produces 6,301 tons per day or an average rate of 1.12 kg/capita/day. The composition of MSW is closely related to the residents' level of economic development and lifestyle. The composition of MSW will be different across districts. In general, the composition of MSW in Libya six major categories of waste was found to contain: organic matter, paper-cardboard, plastics, glass, metals, and miscellaneous (Table 1).

Table 1. Waste composition category [4]

Waste category	Waste components
Organic matter	waste from foodstuff (e.g., food and vegetable refuse, fruit skins, stem of green, corncob, leaves, grass, and manure)
Paper/Cardboard	paper, paper bags, cardboard, corrugated board, box board, newsprint, magazines, tissue, office paper, and mixed paper (e.g., all papers that do not fit into other categories)
Plastic	wrapping film, plastic bags, polythene, plastic bottles, plastic hoses, plastic strings and so forth.
Glass	bottles, glassware, light bulbs, ceramics, and so forth.
Metal	both ferrous and non-ferrous metals including cans, wire, fence, knives, bottle covers, aluminum cans and other aluminum materials, (e.g., foil, ware, and bi-metal)
Wood	Products/ comprised of wood (e.g., tables and chairs).
Miscellaneous	Materials comprised of leather, rubber, fiber, textiles, soils, and more (e.g., yard waste, tires, batteries, large appliances, nappies/sanitary products, medical waste, and so forth).

Organic matter was considered primary category as it represented 59% of the waste collected. The remaining (see Fig. 3) were as follows:

- 12% paper-cardboard
- 8% plastic
- 7% metal
- 4% glass
- 2% wood
- 8% miscellaneous

Demolition and construction wastes were not considered because they are disposed of in uncontrolled open-air sites [8]. The high consumption of fruits and vegetables could explain the preponderance of organic matter in Libya's waste.

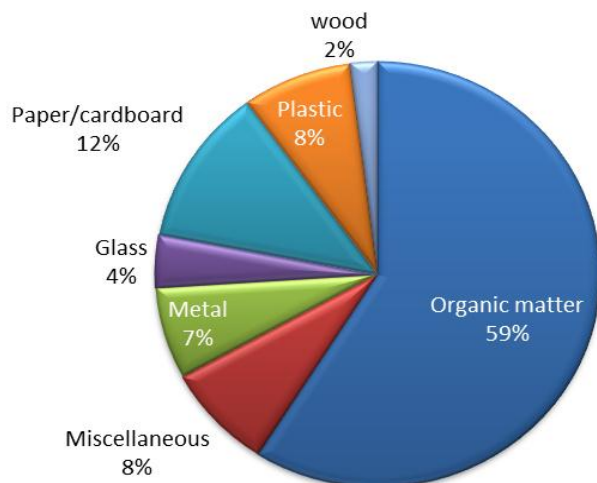

Figure. 3. MSW Composition survey in Libya

2.2. INDUSTRIAL SOLID WASTE

The overall generation of industrial waste, including non-hazardous and inert industrial wastes in Libya, is 1,248,000 tons per year with a stock quantity of 2,196,480 tons [8]. Quantities of industrial waste and composition category are shown in Table 2.

Table 2. Quantities of industrial waste and composition category

Industrial waste	Quantity (ton/yr)
Steel, metallurgical, mechanical, and electrical industries	16×10^4
Building material, ceramic, and glass industries	89×10^3
Chemical, rubber, and plastic industries	34×10^2
Food processing, tobacco, and match industries	65×10^3
Textile, hosiery, and confection industries	68×10^2
Leather and shoe industries	17×10^2
Wood, paper, and printing industries	10×10^3
Total	34×10^4

2.3. HEALTHCARE SOLID WASTE

Healthcare wastes (HSW) include plastic syringes, animal tissues, bandages, cloths, and so forth. This type of waste is produced by the treatment, diagnosis, and immunization of humans and/or animals at hospitals, veterinary and health related research facilities, and medical laboratories. These HSWs contain infectious waste, toxic chemicals, and heavy metals. Several may contain substances that are radioactive. Libya contains 193 hospitals [6, 7] (99 governmental hospitals and 94 private hospitals) with a total of 23,353 beds. It also contains 1484 primary healthcare facilities (Libyan Ministry of Health, 2010). HSWs reach 87,000 tons/year, of which 72% is general waste and 28% is hazardous waste [6, 7].

2.3.1. Generation and Classification of both Hospital and Clinical Waste in Libya. Solid waste generated by each hospital in Libya was weighed, and the average quantity of waste was determined. The highest generation rate of 1.6 kg/patient/day occurred at the Tripoli Medical Center. The lowest rates 0.9 kg/patient/day occurred at the clinics and rural health centers [6, 7]. The hospital waste analyzed was comprised of 28% hazardous waste and 72% general waste. The qualitative analysis of general waste (Fig. 4) revealed that organics were the primary component (38%), with plastic in second place (24%). The high plastic content is the result of a widespread use of disposable, rather than reusable, products (e.g., bottles, packaging materials and bags used for food) intended for various purposes. Paper had the third highest percentage (20%).

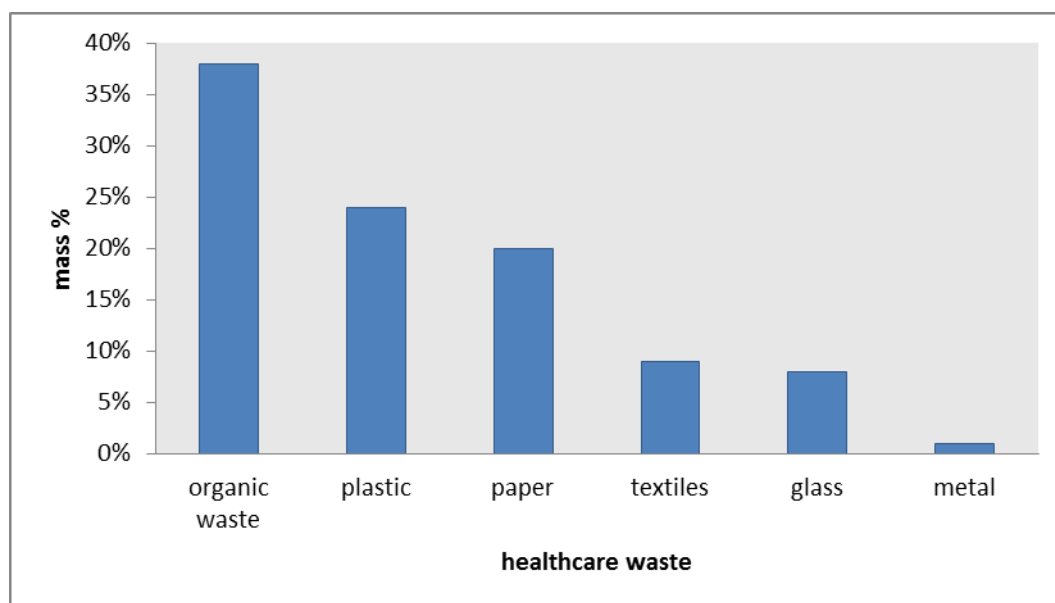

Figure. 4. Classification of general healthcare waste in Libya vs mass%

A classification of hazardous wastes indicates that sharps, infectious pathological wastes, and toxic wastes comprised nearly 28% of all hazardous wastes measured as illustrated in Fig. 5 [6, 7].

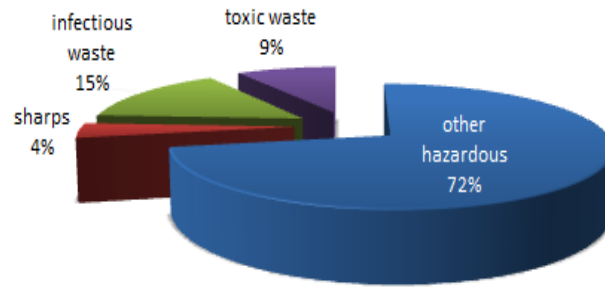

Figure 5. Classification of hazardous healthcare waste in Libya vs mass%

3. SOLID WASTE MANAGEMENT

Elimination is the solution applied to 95% of waste produced in Libya. These wastes are either thrown into open dumps (67%) or burned in the open air in either public dumps or municipal, uncontrolled dump; (30%). Quantities destined for recovery are quite low: only 1% for recycling and 2% for composting, as illustrated in Fig. 6 [6, 7].

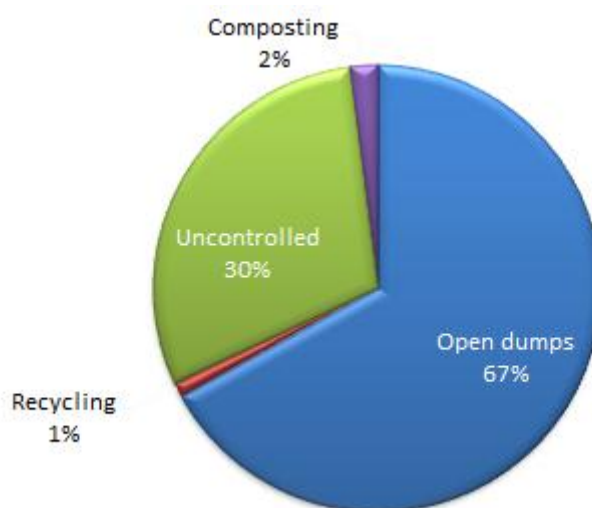

Figure 6. Methods of waste disposal in Libya

3.1. THE OPEN DUMP METHOD

In Libya, the elimination of household and similar wastes through the implementation of open and uncontrolled dumps is the most common method of waste disposal used. Approximately 90% of wastes end up in open dumps. More than 2,300 open dumps have been identified in the country with an area of approximately 3,500 ha [6]. Most of these dumps are nearly saturated.

3.2. LANDFILL MODE

The Libyan government has chosen to use the landfill technique to eliminate municipal solid waste. Unlike the traditional mode in which waste is disposed of in open dumps, the landfill technique stores waste underground. The primary advantages of this technology include the following: (i) This technique offers a universal solution that

provides ultimate waste disposal; (ii) it is relatively inexpensive and easy to implement; (iii) Landfill biogas can be used as a byproduct for both household and industrial uses. Unfortunately, this technology also has several disadvantages. For example, landfills require a large surface area. They also pose serious pollution hazards, including ground water pollution, air pollution, and soil contamination.

3.3. COMPOSTING MODE

Composting is a biological method that is used to recover organic material from solid waste. Composting represents only 2% of all waste produced in Libya [6]. The primary benefit of this technology is that it converts decomposable organic materials into organic fertilizers.

3.4. RECOVERY AND RECYCLING MODE

Solid waste clean and reuse process contribute to the recovery of part of the economic value of solid wastes. They contribute to the provision of work opportunities and financial revenue for the community [7]. Preliminary estimates for Libyan cities revealed that 25% of the waste generated in Libya can be recycled [7]. These recyclable materials include paper, textile materials, metals, plastics, and glass. Unfortunately, only 2% of these are in fact recycled, as presented in Table 3

Table 3. Recycling capacity

Waste	quantity produced (tons/year)	quantity recycled (tons/year)
Paper	75,000	1,080
Textile materials	19,000	420
Metal	20,000	360
Plastics	26,000	660
glass	9,800	480
Total	149,800	3,000

4. WASTE-TO-ENERGY (WTE) CONVERSIONS

The production on energy from waste is not a new concept, though it is a field that requires serious attention. Various energy conversion technologies are available. The selection, however, is based on the physicochemical properties of the waste, both the type and quantity of the available waste feedstock, and the form of energy desired. The conversion of solid waste to energy can be undertaken with three main process technologies: biochemical extraction, thermochemical extraction, and mechanical extraction [9].

4.1. BIOCHEMICAL CONVERSION

Biochemical conversion processes make use of the enzymes in bacteria and other microorganisms to breakdown biomass. This process is one of the few processes that provide environmentally friendly direction for obtaining energy fuel from MSWs [10, 11]. In most cases, microorganisms are used to perform the conversion process by using anaerobic digestion with combined heat, hydrogen and power system (CHHP) and fermentation. Digester and biogas production are shown in Fig. 4-a [12-15]. Fermentation is used commercially, on a large scale, in various countries, to produce ethanol from sugar crops. This method produces diluted alcohols that must be distilled.

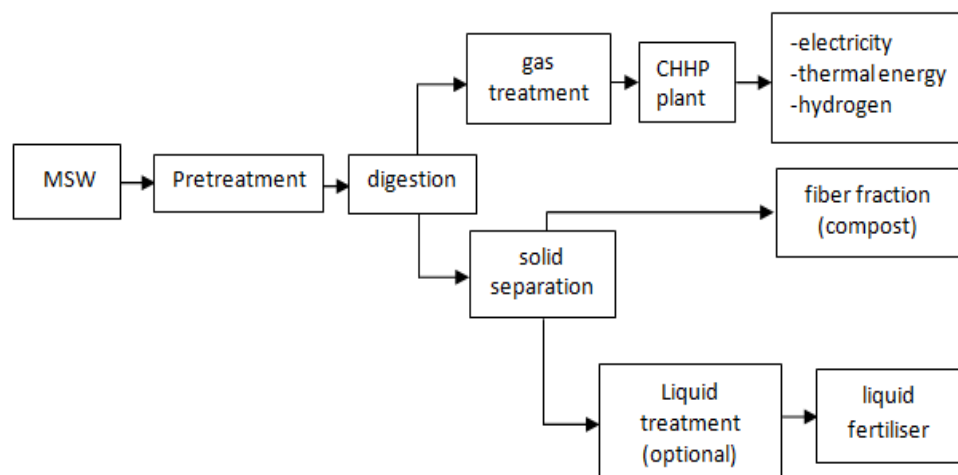

Figure 7. Simplified flow diagram of a general anaerobic digestion plant based of MSW

4.2. THERMOCHEMICAL CONVERSION

Thermal conversion is one component in a number of integrated waste management solutions proposed in various strategies. Four main conversion technologies have emerged for the treatment of both dry and solid wastes: combustion, gasification, pyrolysis, and liquefaction (to produce an intermediate liquid or gaseous energy carrier) as the following list below:

- Combustion is the burning of biomass in air. It is used over a wide range of commercial and industrial combustion plant outputs to convert the chemical energy stored in the solid waste into either heat or electricity. Combustion is using various items of process equipment, such as boilers and turbines. In theory any type of biomass can be burned in practice, however, combustion is feasible only for biomass with a moisture content <50% unless the biomass has been pre-dried [16].
- The gasification process involves treating a carbon-based material with either oxygen or steam to produce a gaseous fuel. Gas produced can be either cleaned and burned in a gas engine or transformed chemically into methanol that can be used as a synthetic compound.
- Pyrolysis is the heating of biomass in the absence of oxygen to produce liquid (termed bio-oil or bio-crude), solid, and gaseous fractions in varying yield. Pyrolysis is depending on a range of parameters such as heating rate, temperature level, particle size, and retention time.
- Liquefaction is the low-temperature cracking of biomass molecules as a result of high pressure to produce a liquid-diluted fuel. Liquefaction is employing only low temperatures of around 200°C to 400°C.

4.3. MECHANICAL EXTRACTION

Mechanical extraction can be used to produce oil from the seeds of solid waste. Rapeseed oil can be processed further by reacting it with alcohol a process known as esterification to obtain biodiesel. The type of energy produced from biogas depends directly on the buyer's needs. These needs can be broken down into three categories: electricity generation, heat and steam generation, and transportation fuel.

4.3.1. Electricity Generation. Electricity generation is the most common form of energy produced in facilities constructed today by using many methods as the following list below:

- Combined heat and power (CHP) generation, also known as cogeneration, is an efficient, clean, and reliable approach to generating both power and thermal energy from solid waste. When a CHP system designed to meet the thermal and electrical base loads is installed. CHP can greatly increase a facility's operational efficiency while decreasing its energy costs, CHP can also reduce greenhouse gasses, which contribute to global climate change [12-15, 17].
- The Conversion of biogas to electricity via fuel cell technology offers significant increases in efficiency and, hence, is a highly sought after technology. Several biogas installations utilize, utilizing molten carbonate fuel cell technology. However, solid oxide fuel cell technology is thought to be the most promising technology due to its higher power density and its applicability to a wide range of scales [18].
- Biogas can be used as a motive power for the production of electricity using engines. A biogas-fueled engine generator will typically convert between 18% and 25% of biogas to electricity. Biogas engine is depending on engine design and load factor.
- Small gas turbines that are specifically designed to use biogas are also available. An advantage to this technology is lower NO_x emissions and lower maintenance costs. These turbines, however, are not as efficient as IC engines. Additionally, they cost more than IC engines.

4.3.2. Heat and Steam Generation. Producing and selling both heat and steam require the existence of available industrial customers. They should be matching the supply with their needs. Steam can also be used at institutional domestic complexes.

4.3.3. Transportation Fuel. Biogas is used as a transportation fuel in a number of countries. It can be upgraded to natural gas quality for use in normal vehicles designed to use natural gas [12-15, 17, 19].

5. RESULTS AND DISCUSSION

5.1. WTE BENEFITS IN LIBYA

Interest in converting waste to energy has recently in Libya because this technology will reduce fossil fuel usage, greenhouse gas emissions, pollution, and landfill dumping. Advanced technologies can be used to generate fuel from waste, reducing the country's dependence on increasingly scarce and expensive non-renewable fossil-fuel resources. Using waste as a feedstock for energy production reduces the pollution caused by burning fossil fuels. Traditional incineration produces CO_2 and pollutants. We can observe that biogas from waste landfill contains 55% CH_4 has a calorific value of 21.5 MJ/Nm^3 while pure CH_4 has a calorific value 35.8 MJ/Nm^3 this is the reason to remove CO_2 from raw biogas. The energy balance of biogas is highly important, which can replace many other form of combustible, and figure (8) illustrates the calorific value that can be replaced by methane. Advanced methods (e.g., gasification, pyrolysis, and liquefaction) have the potential to provide a double benefit: reduced CO_2 emissions as compared to incineration and coal plants and reduced methane emissions from landfills. Landfills require large amounts of land that could be used for other purposes; the incineration of solid waste can generate energy while reducing the volume of waste by up to 80%.

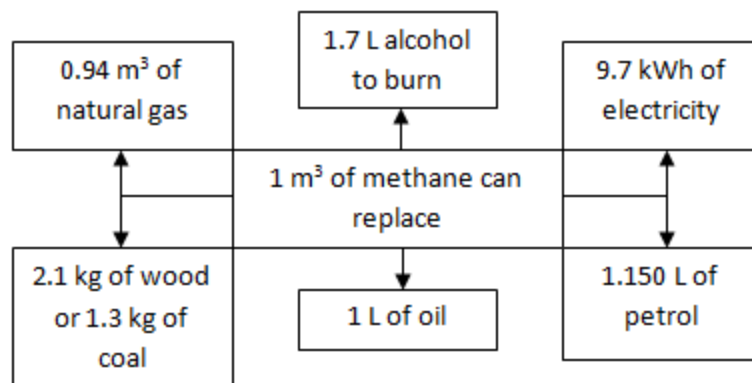

Figure 8. Energy equivalence of methane

5.2. WTE CHALLENGES

Many WTE technologies are designed to handle only a few types of waste (biomass, solid waste, and so forth). Completely separating different types of waste can be tremendously difficult. Determining the exact composition of a waste source can be nearly impossible. WTE technologies must either become more versatile or be supplemented by material handling and sorting systems if they are to be successful. There are many WTE challenges (e.g., Waste-gas cleanup, conversion efficiency, regulatory hurdles, and high capital costs). The gas generated by various processes (e.g., pyrolysis and thermal gasification) must be cleaned of tars and particulates before clean, efficient fuel can be produced. A number of WTE pilot plants, particularly those using energy-intensive techniques (e.g., plasma), have functioned with low efficiency. Toxic materials include both trace metals (e.g., lead, cadmium and mercury), and trace organics (e.g., dioxins and furans). Such toxins pose an environmental problem if they are released into the air, dispersed into the soil, allowed to migrate into ground water supplies, or make their way into the food chain. The control of such toxins and air pollution is a key feature of environmental regulations governing MSW-fueled electric generation. The regulatory climate for WTE technologies can be extremely complex. These regulations may prohibit a particular method (typically incineration) due to air-quality concerns. Although changes in the power industry have allowed small producers to compete with established power utilities in many areas, the electrical grid is still protected by yet more regulations. These regulations pose as obstacles to would-be waste-energy producers. WTE systems are often quite expensive to install. Despite the financial benefits they promise, the high installation cost is a major hurdle, particularly for new technologies that are not widely established in the market. Figure (9) illustrates possible fossil fuel and hydrogen prices up to the year 2015. This image suggests that, although fossil fuel prices are predicted to increase, hydrogen prices are predicted to decrease. By 2018 these price will cross each other at the \$10GJ-1 range. However, because hydrogen has a higher utilization efficiency ($\eta=1.35$), hydrogen prices will be competitive with those of fossil fuels by approximately 2015.

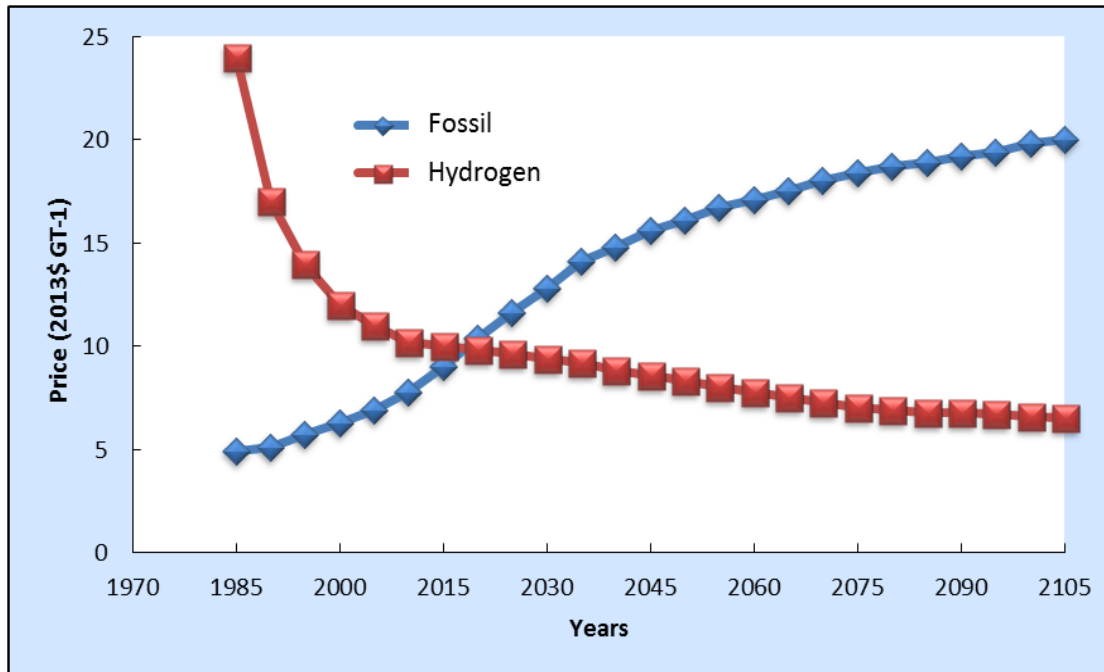

Figure 9. Fossil fuel and hydrogen price predictions vs. time

6. CONCLUSION

This paper presents an overview on solid waste that can be used as a source of bioenergy in Libya including MSW, ISW, and HSW as biomass sources. The management of solid waste and valorization is based on an understanding of MSW's composition and physicochemical characteristics. Energy from waste is not a new concept, but it is a field that requires serious attention. Various energy conversion technologies (thermochemical extraction, biochemical extraction, and mechanical extraction) can produce useful products (e.g., electricity, heat, and transportation fuel). The dependence of Libya on fossil fuels will be reduced, and significantly reducing both pollution and greenhouse gas emissions. Solid waste can be used as an energy source in Libya. The Implementation of landfill disposal techniques should be encouraged for the valorization of biogas.

ACKNOWLEDGMENTS

The authors would like to thank the Libyan Ministry of Higher Education for their financial support.

REFERNCES

- [1] Larrasoana JC, Roberts AP, Rohling EJ, Winklhofer M, Wehausen R, “Three million years of monsoon variability over the northern sahara,” *Journal of Climate Dynamics*, Vol. 21, Pp. 689-698, (2003).
- [2] ElJrushi GS, VeziroTglu T, “Solar-hydrogen energy system for Libya,” *Journal of Int J Hydrogen Energy*, Vol. 15, Pp. 885-894, (1990).
- [3] Hawas MM, Muneer T, “Monthly average daily insolation on tilted collectors in Libya,” *Journal of Energy Conversion and Management*, Vol. 30, No.3, Pp. 213-218, (1980).
- [4] Eddine BT, Salah MM. “Solid waste as renewable source of energy: Current and future possibility in Algeria,” *Journal of International Journal of Energy and Environmental Engineering*, Vol. 3, No. 1, Pp. 1-12, (2012).
- [5] Sadek I, Fatiha S, Aïcha S, Nouar M, Amar C, “Renewable energy potential generated by organic waste in Algeria,” *Journal of International Journal of Renewable Energy Research*, Vol. 3, No. 1, Pp. 109-113, (2013).
- [6] Sawalem M, Selic E, Herbell J. “Hospital waste management in Libya: A case study,” *Journal of Waste Management*, Vol. 29, No.4, Pp. 1370-1375, (2009).
- [7] Alhamroush A, Altabet A. Hospital waste in Misurata (problems, effects and methods of disposal), Master’s thesis, Medical Technical College, Alfath University, Libya, (2005).
- [8] Gebril AO, Omran A, Pakir AHK, Aziz HA, “Municipal solid waste management in Benghazi (LIBYA): Current practices and challenges,” *Journal of Environmental Engineering and Management Journal*, Vol. 9, No.9, Pp. 1289-1296, (2010).
- [9] Cantrell KB, Ro KS, Szögi A A, Vanotti MB, Smith MC, Hunt PG, “Green farming systems for the southeast USA using manure-to-energy conversion platforms,” *Journal of Journal of Renewable and Sustainable Energy*, Vol. 4, No.4, Pp. 041401, (2012).
- [10] Odlare M, Arthurson V, Pell M, Svensson K, Nehrenheim E, Abubaker J, “Land application of organic waste - effects on the soil ecosystem,” *Journal of Applied Energy*, Vol. 88, No.6, Pp. 2210-2218, (2011).
- [11] Pant D, Van Bogaert G, Diels L, Vanbroekhoven K.A, “review of the substrates used in microbial fuel cells (MFCs) for sustainable energy production,” *Journal of Bioresource Technology*, Vol. 101, No.6, Pp. 1533-1543, (2010).

- [12] Hamad TA, Agll AA, Hamad YM, Bapat S, Thomas M, Martin KB, et al, "Hydrogen recovery, cleaning, compression, storage, dispensing, distribution system and End-Uses on the university campus from combined heat, hydrogen and power system, " *Journal of Int J Hydrogen Energy*, Vol. 39, Pp. 647-653,(2014).
- [13] Hamad TA, Agll AA, Hamad YM, Bapat S, Thomas M, Martin KB, et al, "Study of a molten carbonate fuel cell combined heat, hydrogen and power system: End-use application," *Journal of Case Studies in Thermal Engineering*, Vol. 1, Pp. 45-50,(2013).
- [14] Hamad TA, Agll AA, Hamad YM, Bapat S, Thomas M, Martin KB, et al, "Study of combined heat, hydrogen and power system based on a molten carbonate fuel cell fed by biogas produced by anaerobic digestion," *Journal of Energy Conversion and Management*, Vol. 81, Pp. 184-191,(2014).
- [15] Agll AA, Hamad YM, Hamad TA, Bapat S, Thomas M, Martin KB, et al, "Study of a molten carbonate fuel cell combined heat, hydrogen and power system: Energy analysis," *Journal of App Thermal Eng*, Vol. 59, Pp. 634-638, (2013).
- [16] He C, Giannis A, Wang J, "Conversion of sewage sludge to clean solid fuel using hydrothermal carbonization: Hydrochar fuel characteristics and combustion behavior," *Journal of Applied Energy*, Vol. 111, Pp. 257-266, (2013).
- [17] Hamad TA, Agll AA, Hamad YM, Bapat S, Thomas M, Martin KB, et al, "Hydrogen production and End-Uses from combined heat, hydrogen and power system by using local resources," *Journal of Renewable Energy*, Vol. 71,Pp. 381-386, (2014).
- [18] Xuan J, Leung MKH, Leung DYC, Ni M, "A review of biomass-derived fuel processors for fuel cell systems," *Journal of Renewable and Sustainable Energy Reviews*, Vol. 13, No. 6-7, Pp. 1301-1313, (2009).
- [19] Uusitalo V, Soukka R, Horttanainen M, Niskanen A, Havukainen J, "Economics and greenhouse gas balance of biogas use systems in the finnish transportation sector," *Journal of Renewable Energy*, Vol. 51, Pp. 132-140.

2. CONCLUSIONS

As part of Task I, we have discussed the design of a CHHP system for the Missouri University of Science and Technology campus using local resources. An energy flow and resource availability study is performed to identify the type and source of feedstock required to continuously run the fuel cell system at peak capacity. Following the resource assessment study, the team selects FuelCell Energy DFC1500TM unit for its fuel cell. The CHHP system provides electricity to power the university campus, thermal energy for heating the anaerobic digester, and hydrogen for transportation, back-up power and other needs. The CHHP system will be able to provide approximately 22,000 kWh and 650 kg of hydrogen to the university campus per day. In conclusion, the CHHP system will reduce energy consumption, fossil fuel usage, and greenhouse gas (GHG) emissions at the Missouri S&T campus. It will be able to provide approximately 27% of the university campus' electricity need. In task II, presents an overview on solid waste that can be used as a source of bioenergy in Libya including MSW, ISW, and HSW as biomass sources. The management of solid waste and valorization is based on an understanding of MSW's composition and physicochemical characteristics. Energy from waste is not a new concept, but it is a field that requires serious attention. Various energy conversion technologies (thermochemical extraction, biochemical extraction, and mechanical extraction) can produce useful products (e.g., electricity, heat, and transportation fuel). The dependence of Libya on fossil fuels will be reduced, and significantly reducing both pollution and greenhouse gas emissions. Solid waste can be used as an energy source in Libya. The Implementation of landfill disposal techniques should be encouraged for the valorization of biogas.

BIBLIOGRAPHY

- [1] Hamad TA, Agll AA, Hamad YM, Bapat S, Thomas M, Martin KB, et al, "Hydrogen recovery, cleaning, compression, storage, dispensing, distribution system and End-Uses on the university campus from combined heat, hydrogen and power system, " *Journal of Int J Hydrogen Energy*, Vol. 39, Pp. 647-653,(2014).
- [2] Hamad TA, Agll AA, Hamad YM, Bapat S, Thomas M, Martin KB, et al, "Study of a molten carbonate fuel cell combined heat, hydrogen and power system: End-use application," *Journal of Case Studies in Thermal Engineering*, Vol. 1, Pp. 45-50,(2013).
- [3] Hamad TA, Agll AA, Hamad YM, Bapat S, Thomas M, Martin KB, et al, "Hydrogen production and End-Uses from combined heat, hydrogen and power system by using local resources," *Journal of Renewable Energy*, Vol. 71, Pp. 381-386,(2014).
- [4] Hamad TA, Agll AA, Hamad YM, Bapat S, Thomas M, Martin KB, et al, "Study of combined heat, hydrogen and power system based on a molten carbonate fuel cell fed by biogas produced by anaerobic digestion," *Journal of Energy Conversion and Management*, Vol. 81, Pp. 184-191,(2014).
- [5] Yu M , Muy S, Quader F, Bonifacio A, Varghese R , Clerigo E, et al, "Combined Hydrogen, Heat and Power (CHHP) pilot plant design," *Journal of Int J Hydrogen Energy*, Vol. 38, No.12, Pp. 488-4888,(2013).
- [6] Vera D, Jurado F, de Mena B, Schories G, "Comparison between externally fired gas turbine and gasifier-gas turbine system for the olive oil industry," *Journal of Int Energy*, Vol. 36, No.12, Pp. 6720-6730,(2011).
- [7] Bouckaert S, Assoumou E, Selosse S, Maïzi N, "A prospective analysis of waste heat management at power plants and water conservation issues using a global TIMES model," *Journal of Int Energy*, Vol. 68, Pp. 80-91,(2014).
- [8] Pronto JL, Gooch CA, "Greenhouse gas emission reductions for seven on-farm dairy manure-based anaerobic digestion systems - Final results," *Journal of ASABE*, Vol. 7, Pp. 35-42,(2010).
- [9] Cantrell KB, Ducey T, Ro, KS, "Livestock waste-to-bioenergy generation opportunities," *Journal of Bioresource Technol*, Vol. 99, Pp. 7941-7953, (2008).
- [10] Ghaderi A, Parsa Moghaddam M, Sheikh-El-Eslami MK, "Energy efficiency resource modeling in generation expansion planning," *Journal of Energy*, Vol. 68, Pp. 529-537,(2014).

- [11] Larrasoana JC, Roberts AP, Rohling EJ, Winklhofer M, Wehausen R, “Three million years of monsoon variability over the northern sahara,” *Journal of Climate Dynamics*, Vol. 21, Pp. 689-698, (2003).
- [12] ElJrushi GS, VeziroTglu T, “Solar-hydrogen energy system for Libya,” *Journal of Int J Hydrogen Energy*, Vol. 15, Pp. 885-894, (1990).
- [13] Hawas MM, Muneer T, “Monthly average daily insolation on tilted collectors in Libya,” *Journal of Energy Conversion and Management*, Vol. 30, No.3, Pp. 213-218, (1980).
- [14] Sawalem M, Selic E, Herbell J. “Hospital waste management in Libya: A case study,” *Journal of Waste Management*, Vol. 29, No.4, Pp. 1370-1375, (2009).
- [15] Alhamroush A, Altabet A. Hospital waste in Misurata (problems, effects and methods of disposal), Master’s thesis, Medical Technical College, Alfath University, Libya, (2005).

VITA

Tarek Hamad was born on February 04, 1978 in Elbyda, Libya. After completing his elementary and high schools in different cities in Libya, he enrolled in the Omar Al-Mukhtar University. In May 1999, he received his B.E. in Mechanical Engineering from Omar Al-Mukhtar University, Elbyda, Libya. After graduation, he was employed by LG Company from August 1999 to July 2002. He enrolled in Al-Fatheh University to begin his graduate study in Mechanical Engineering. He received a Master of Science degree in Mechanical Engineering in September 2007 from Al-Fatheh University, Tripoli, Libya. Following graduation, he came to Missouri University of Science and Technology, Rolla, Missouri in August, 2011. Since then, he pursued his doctoral degree in Mechanical Engineering. During this period he held the position of graduate teaching assistant in the department of mechanical and aerospace engineering. He was a Member of the Missouri University Science and Technology Hydrogen Design Team. In December, 2014, he received a Master degree of Geological Engineering. In May, 2015, he received his Ph.D. in Mechanical Engineering from Missouri University of Science and Technology, Rolla, Missouri.