Doctoral Dissertations

Student Theses and Dissertations

Spring 2019

Reliability analysis for systems with outsourced components

Zhengwei Hu

Follow this and additional works at: https://scholarsmine.mst.edu/doctoral_dissertations



Part of the [Mechanical Engineering Commons](#), and the [Statistics and Probability Commons](#)

Department: **Mechanical and Aerospace Engineering**

Recommended Citation

Hu, Zhengwei, "Reliability analysis for systems with outsourced components" (2019). *Doctoral Dissertations*. 2779.

https://scholarsmine.mst.edu/doctoral_dissertations/2779

This thesis is brought to you by Scholars' Mine, a service of the Missouri S&T Library and Learning Resources. This work is protected by U. S. Copyright Law. Unauthorized use including reproduction for redistribution requires the permission of the copyright holder. For more information, please contact scholarsmine@mst.edu.

RELIABILITY ANALYSIS FOR SYSTEMS WITH OUTSOURCED COMPONENTS

by

ZHENGWEI HU

A DISSERTATION

Presented to the Faculty of the Graduate School of the
MISSOURI UNIVERSITY OF SCIENCE AND TECHNOLOGY

In Partial Fulfillment of the Requirements for the Degree

DOCTOR OF PHILOSOPHY

in

MECHANICAL ENGINEERING

2019

Approved by:

Dr. Xiaoping Du, Advisor
Dr. K. Chandrashekhara
Dr. Lokeswarappa Dharani
Dr. Serhat Hosder
Dr. Daniel C. Conrad

© 2019

Zhengwei Hu

All Rights Reserved

PUBLICATION DISSERTATION OPTION

This dissertation consists of the following four articles that have been published or submitted for publication.

Paper I, pages 7-38, have been published in the Special Issue “Uncertainty Quantification for Engineering Design” of Artificial Intelligence for Engineering Design, Analysis and Manufacturing.

Paper II, pages 39-67, have been published in ASME Journal of Mechanical Design.

Paper III, pages 68-106, have been submitted to Artificial Intelligence for Engineering Design, Analysis and Manufacturing.

Paper IV, pages 107-139 have been submitted to Special Issue "Risk, Reliability, and Uncertainty Quantification in Automotive Applications" in ASCE-ASME Journal of Risk and Uncertainty in Engineering Systems. The paper has been presented and published in the proceedings of the ASME 2018 International Design Engineering Technical Conferences and Computers & Information in Engineering Conference (IDETC/CIE 2018), August 26-29, Quebec City, Quebec, Canada.

ABSTRACT

The current business model for many industrial firms is to function as system integrators, depending on numerous outsourced components from outside component suppliers. This practice has resulted in tremendous cost savings; it makes system reliability analysis, however, more challenging due to the limited component information available to system designers. The component information is often proprietary to component suppliers. Motivated by the need of system reliability prediction with outsourced components, this work aims to explore feasible ways to accurately predict the system reliability during the system design stage. Four methods are proposed. The first method reconstructs component reliability functions using limited reliability data with respect to component loads, and the system reliability is then estimated statistically. The second method applies two-class support vector machines (SVM) to approximate limit-state functions of outsourced components based on the categorical reliability dataset. With the integration of the obtained limit-state functions and those of in-house components, the joint probability density function of all the components is estimated, thereby leading to accurate system reliability prediction. The third method is an extension of the second one, and a one-class SVM is proposed to rebuild limit-state functions for outsourced components given only the failure dataset. The last method deals with the case where no reliability dataset is available. A partial safety factor method is developed, which enables component suppliers to provide sufficient information to system designers for accurate reliability analysis without revealing the proprietary design details. Both numerical examples and engineering applications demonstrate the accuracy and effectiveness of the proposed methods.

ACKNOWLEDGEMENTS

First and foremost I would like to express my sincere appreciation towards my advisor, Dr. Xiaoping Du. for his time, ideas, patience, immense knowledge and continuous support of my Ph.D. study and related research. Without his excellent guidance and encouragement, this dissertation would not have been possible. His rigorous attitude, creative thinking, great enthusiasm to teaching, and his modesty in life will definitely have a profound influence on my future life and career.

My dissertation committee guided me through all these years. Thank you to Dr. K. Chandrashekhara, Dr. Lokeswarappa Dharani, Dr. Serhat Hosder, and Dr. Daniel C. Conrad for their insightful comments and time commitment to this research.

Also I want to thank my labmates and friends Dr. Zhen Hu, Dr. Zhifu Zhu, Dr. Yao Cheng, Mr. Guannan Liu, Mr. Zhangli Hu, Mr. Hao Wu, Mr. Xinpeng Wei, Dr. Fangping Yuan, Dr. Xin Wang, Mr. Chao Zhang, and Mr. Junji Huang for their help during my study and life in Rolla. I also would like to thank Ms. Erendira Jauregui at Hussmann Corporation for her support and help for my summer research project. The financial support from National Science Foundation through Grant CMMI 1234855, CMMI 1562593, and the Intelligent Systems Center (ISC) at Missouri University of Science and Technology are greatly appreciated.

Lastly, I would like to express my deepest appreciation and love to my wife, Sha Zhu, my son Yukun Hu, my parents, my parents in law, my sister, my brother in law, and relatives for their love, encouragement, patience, and support.

TABLE OF CONTENTS

	Page
PUBLICATION DISSERTATION OPTION.....	iii
ABSTRACT.....	iv
ACKNOWLEDGEMENTS.....	v
LIST OF ILLUSTRATIONS.....	xi
LIST OF TABLES.....	xiii
 SECTION	
1. INTRODUCTION	1
1.1 BACKGROUND	1
1.2 RESEARCH OBJECTIVE	3
1.3 ORGANIZATION OF DISSERTATION	6
 PAPER	
I. SYSTEM RELIABILITY PREDICTION WITH SHARED LOAD AND UNKNOWN COMPONENT DESIGN DETAILS	7
ABSTRACT.....	7
1. INTRODUCTION	8
2. REVIEW OF SYSTEM RELIABILITY ANALYSIS	12
2.1 SYSTEM RELIABILITY WITH INDEPENDENT COMPONENT STATES.....	12
2.2 SYSTEM RELIABILITY BOUNDS	13
2.3 SYSTEM RELIABILITY WITH COMPONENTS SHARING THE SAME SYSTEM LOAD.....	14

3. SYSTEM RELIABILITY ANALYSIS WITH SHARED LOAD AND UNKNOWN COMPONENT DETAILS	15
3.1 PROCEDURE OF SYSTEM RELIABILITY PREDICTION	16
3.2 FORMULATE COMPONENT RELIABILITY FUNCTIONS	18
3.2.1 Kriging Method	18
3.2.2 Weibull Method	20
3.3 RECONSTRUCT COMPONENT LIMIT-STATE FUNCTIONS	21
3.4 SYSTEM RELIABILITY ANALYSIS	25
4. EXAMPLE	28
5. CONCLUSIONS	35
ACKNOWLEDGEMENTS	37
REFERENCES	37
II. INTEGRATION OF STATISTICS- AND PHYSICS-BASED METHODS – A FEASIBILITY STUDY ON ACCURATE SYSTEM RELIABILITY PREDICTION	39
ABSTRACT	39
1. INTRODUCTION	40
2. METHODOLOGY REVIEW	43
2.1 SUPPORT VECTOR MACHINE (SVM)	43
2.2 FIRST ORDER RELIABILITY METHOD (FORM)	45
3. SYSTEM RELIABILITY PREDICTION WITH COMBINED PHYSICS- AND STATISTICS-BASED METHODS	46
3.1 CONSTRUCT A LIMIT-STATE FUNCTION FOR A TYPE II COMPONENT	47
3.2 SYSTEM RELIABILITY ANALYSIS	48
4. EXAMPLES	51

4.1 EXAMPLE 1 – A MATHEMATICAL PROBLEM	51
4.2 EXAMPLE 2– A CANTILEVER BEAM PROBLEM WITH MULTIPLE FAILURE MODES	54
4.3 EXAMPLE 3 – A SYSTEM WITH MULTIPLE COMPONENTS.....	60
5. CONCLUSIONS.....	64
ACKNOWLEDGEMENTS.....	66
REFERENCES	66
III. ONE-CLASS SUPPORT VECTOR MACHINES WITH A BIAS CONSTRAINT AND ITS APPLICATION IN SYSTEM RELIABILITY PREDICTION.....	68
ABSTRACT.....	68
1. INTRODUCTION	69
2. METHODOLOGY REVIEW.....	71
2.1 GENERAL SUPPORT VECTOR MACHINE METHODOLOGY	71
2.2 GENERAL ONE-CLASS SUPPORT VECTOR MACHINE.....	74
3. A NEW ALGORITHM FOR ONE-CLASS SUPPORT VECTOR MACHINES WITH A BIAS CONSTRAINT	76
4. APPLICATION OF THE NEW ONE-CLASS SVM IN SYSTEM RELIABILITY PREDICTION.....	81
4.1 PHYSICS-BASED RELIABILITY METHODS	82
4.2 STATISTICS-BASED RELIABILITY METHODS.....	84
4.3 APPLICATION OF THE NEW METHOD	84
4.4 SYSTEM RELIABILITY ANALYSIS	85
5. EXAMPLES	90
5.1 NUMERICAL EXAMPLE.....	90
5.2 ENGINEERING EXAMPLE.....	95
6. CONCLUSIONS.....	102

ACKNOWLEDGEMENTS.....	103
REFERENCES	103
IV. A PARTIAL SAFETY FACTOR METHOD FOR SYSTEM RELIABILITY PREDICTION WITH OUTSOURCED COMPONENTS	107
ABSTRACT.....	107
1. INTRODUCTION	108
2. METHODOLOGY REVIEW.....	111
2.1 FIRST ORDER RELIABILITY METHOD (FORM).....	111
2.2 SECOND ORDER RELIABILITY METHOD (SORM).....	113
2.3 MONTE CARLO SIMULTATION (MCS)	115
2.4 PARTIAL SAFETY FACTOR (PSF)	116
3. SYSTEM RELIABILITY PREDICTION WITH PSFS.....	117
4. SYSTEM-LEVEL ANALYSIS.....	118
5. COMPONENT-LEVEL ANALYSIS.....	121
6. COMPLETE PROCEDURE.....	123
7. EXAMPLES	125
7.1 MATHEMATICAL EXAMPLE	125
7.1.1 Component-Level Analysis	125
7.1.2 System-Level Analysis	130
7.1.3 Result Validation	130
7.2 ENGINEERING EXAMPLE.....	132
7.2.1 Component-Level Analysis	133
7.2.2 System-Level Analysis	135
7.2.3 Result Validation	136

8. CONCLUSIONS..... 137
ACKNOWLEDGEMENTS 137
REFERENCES 138

SECTION

2. CONCLUSIONS..... 140
BIBLIOGRAPHY 142
VITA 144

LIST OF ILLUSTRATIONS

SECTION	Page
Figure 1.1 Relationship between papers in the dissertation.....	6
 PAPER I	
Figure 1 A series system.....	13
Figure 2 Flowchart of the proposed method.....	17
Figure 3 Component reliability data.....	20
Figure 4 The complete p_f model.....	21
Figure 5 Lifting system.....	28
Figure 6 Cross-section of the spreader beam.....	28
Figure 7 Fitted probability of failure for Component 1.....	34
Figure 8 Fitted probability of failure for Component 2.....	34
 PAPER II	
Figure 1 Marginal classifiers along with support vectors.....	44
Figure 2 Training points classification using SVM.....	53
Figure 3 A cantilever beam system.....	55
Figure 4 A crank-slider system.....	60
 PAPER III	
Figure 1 Marginal classifiers along with support vectors.....	72
Figure 2 Basic principle of general one-class SVM.....	74
Figure 3 Basic principle of the proposed one-class SVM.....	78
Figure 4 Geometric meaning of $d_i + \beta$	78

Figure 5 Schematic diagram of the proposed method 89

Figure 6 Support vectors and optimal hyperplane 93

Figure 7 A cantilever beam system..... 96

PAPER IV

Figure 1 Flowchart of the proposed method 124

Figure 2 A hoisting device 132

LIST OF TABLES

PAPER I	Page
Table 1 Detailed information of Component 1	29
Table 2 Reliability data of Component 1	30
Table 3 Detailed information of Component 2	31
Table 4 Reliability data of Component 2	32
Table 5 Information available to system designers.....	33
Table 6 Results of system reliability prediction	35
 PAPER II	
Table 1 Training points.....	52
Table 2 Results of system reliability from different methods	54
Table 3 Basic random variables	56
Table 4 Deterministic parameters	57
Table 5 Results of system reliability.....	59
Table 6 Random variables	62
Table 7 Deterministic parameters	63
Table 8 Results of system reliability.....	64
 PAPER III	
Table 1 Training points.....	92
Table 2 Results of system reliability from different methods	95
Table 3 Basic random variables	97
Table 4 Deterministic parameters	98
Table 5 Training points for FM3	99

Table 6 Results from different methods.....	101
---	-----

PAPER IV

Table 1 Distribution of basic random variables for Component 1.....	125
---	-----

Table 2 Distribution of basic random variables for Component 2.....	129
---	-----

Table 3 Results from different methods.....	131
---	-----

Table 4 Distribution of basic random variables for Component 1.....	133
---	-----

Table 5 Distribution of basic random variables for Component 2.....	135
---	-----

Table 6 Results from different methods.....	136
---	-----

SECTION

1. INTRODUCTION

1.1 BACKGROUND

The current business model for many industrial firms is to function as system integrators, depending on numerous outside component suppliers to support the product design and development. For example, numerous parts of vehicles are designed and manufactured outside except for engines and powertrains that the automaker wants to keep in-house. This practice has resulted in tremendous cost savings in product development [1, 2]. One downside of this practice, however, is a more difficult reliability analysis for new products or systems.

System reliability is the ability that a system performs its intended function. It is often measured by the probability that the system can work properly without any failure. Since a system is composed of multiple components, its reliability depends on the reliability of each component and the dependency between components. Accurate system reliability prediction requires the joint probability density function (PDF) of all the component states, which may not be available without knowing the design details of all the components such as concrete structures, manufacturing processes, and material properties. It is therefore difficult or even impossible to obtain the joint PDF. In addition, different working conditions may also make it hard to re-evaluate the component reliability for the system designers. Generally, an existing component is designed for a given environment, such as a given distribution of a load. The component reliability is then assessed and is validated under the given environment by the component designers.

When the component is to be used in a new environment for a new product, the component reliability will change, making a new system reliability analysis necessary.

In the past decades, many methods were developed to estimate system reliability. A very effective and widely-used method is the independence assumption approach [3], which assumes that all the component states are independent. It does not require system designers to know component design details, which are proprietary to component suppliers. Thus, it is particularly easy to use for systems with outsourced components. For example, for a serial system, the system reliability could be easily calculated by the product of all the component reliabilities. The major drawback of the independence assumption approach is the poor accuracy when component states are strongly dependent. To improve the accuracy, researchers proposed new methodologies to obtain narrower system reliability bounds [4-7], which require design details of all the components, making the methods not applicable for systems with outsourced components.

On the other hand, traditional physics-based methods are good choices for reliability analysis with in-house components, such as the First Order Reliability Method (FORM) [8, 9], the Second Order Reliability Method (SORM) [10], the Saddlepoint Approximation method (SPA) [11], Stress-Strength Interference Theory (SSIT) [12], Monte Carlo Simulation (MCS) [13], and Matrix-Based System Reliability (MSR) method [14]. If the limit-state functions of all the components are known, it is possible to accurately estimate the system reliability composed of only in-house components.

In addition to using physics models, the other way to create limit-state functions is through statistical learnings. With the dramatic improvements of computer capability, statistics-based methods become more and more popular in reliability analysis, such as

Support Vector Machines [15, 16], Neural Networks [17], Kriging surrogate [18, 19], and Logistic Regression [20]. Given sufficient training points these statistical methods could construct reliability models of the outsourced components with very high accuracy.

However, methodologies for systems reliability analysis with both in-house and outsourced components are still limited. Motivated by the lack of effective reliability methods for this kind of issues, we developed methodologies as discussed in this dissertation. Although the proposed methods are for specific engineering applications, the outcomes of this research demonstrate that it is possible to accurately estimate system reliability with both in-house and outsourced components by automatically accommodating the component dependencies.

1.2 RESEARCH OBJECTIVE

The objective of this dissertation is to develop accurate and efficient reliability methodologies for systems with both in-house and outsourced components. To achieve this objective, four research tasks are performed.

Research task 1 (RT1) focuses on system reliability prediction with unknown component design details. This research task is to investigate the feasibility of accurately predicting system reliability without component design details. This task creates a continuous reliability function with respect to the component load for each of the component in the system. The function construction is based on probabilistic data of component failure, and the data may be discrete or tabulated. Without knowing component design details, for each of the components, system designers construct a component limit-state function no matter how many failure modes a component may

have. The reconstructed component limit-state function can then predict the state of the component (either a working state or failure state). Therefore, the system reliability can be accurately predicted with all the available limit-state functions. This research task results in Paper 1 [21].

Research task 2 (RT2) concentrates on analyzing system reliability with both in-house and outsourced components. In this task, system designers have access to the design details of in-house components; however, they could only obtain limited reliability data for outsourced components, which are given in the form of observations of design variables at certain state (either safe or failed). An integrated statistics- and physics-based method is developed. The method employs FORM directly for in-house components. For outsourced components whose reliability is estimated by a statistics-based method, a supervised learning strategy through two-class SVM is applied. Trained by the limited categorical reliability data, the SVM model approximates an optimal separating hyperplane, thereby producing a linear limit-state function that reveals the relationship between component states and design variables. With the limit-state functions of all the components in the system available, it is possible to predict the system reliability accurately. This research task produces Paper 2 [22].

Research task 3 (RT3) develops a new method for system reliability analysis with both in-house and outsourced components. This task is the extension of RT2 in cases where only failure data are recorded. A one-class SVM with a bias constraint is developed to approximate the limit-state functions of outsourced components given only the training points in failure states. Different from the existing one-class SVM methods, there is a bias constraint in the SVM model because the constraint comes from the

probability of failure estimated from the failure data. The one-class failure data is maximally separated from a hypersphere whose radius is determined by the known probability of failure. The limit-state function is then regressed and directly links the states of components with design variables. This makes it possible to obtain the joint probability density of all the component states of the system, resulting in a more accurate prediction of system reliability. This research task produces Papers 3 [23].

Research task 4 (RT4) focuses on developing a new system reliability method linking both component-level and system-level analyses. At the component level, the proposed method enables component suppliers to provide enough information to system designers without revealing their component design details. At the system level, the proposed method helps system designers produce a complete joint PDF of all the component states. A partial safety factors (PSFs) method is proposed. PSFs are specified by component suppliers for shared loads from the system with physics-based reliability approaches. Then system designers use the PSFs from component suppliers to reconstruct equivalent component limit-state functions and realize accurate system reliability prediction. This research task produces Paper 4 [24].

The outcomes of above research tasks are expected to enable engineers to understand how component dependency affects the system reliability estimation and how component limit-state functions are reconstructed at system analysis level with limited reliability data even if the component design details are unknown. This research will benefit new product development in which reliability is a critical design criterion, especially for product with outsourced components. With the accurate system reliability

prediction during the design stage, this research will help system designers in decision-making and shorten the design cycle, thereby resulting in cost savings.

1.3 ORGANIZATION OF DISSERTATION

As discussed in Section 1.2, the four research tasks in this study have produced four papers, which constitute this dissertation. The relationship between these papers are shown in Figure 1.1.

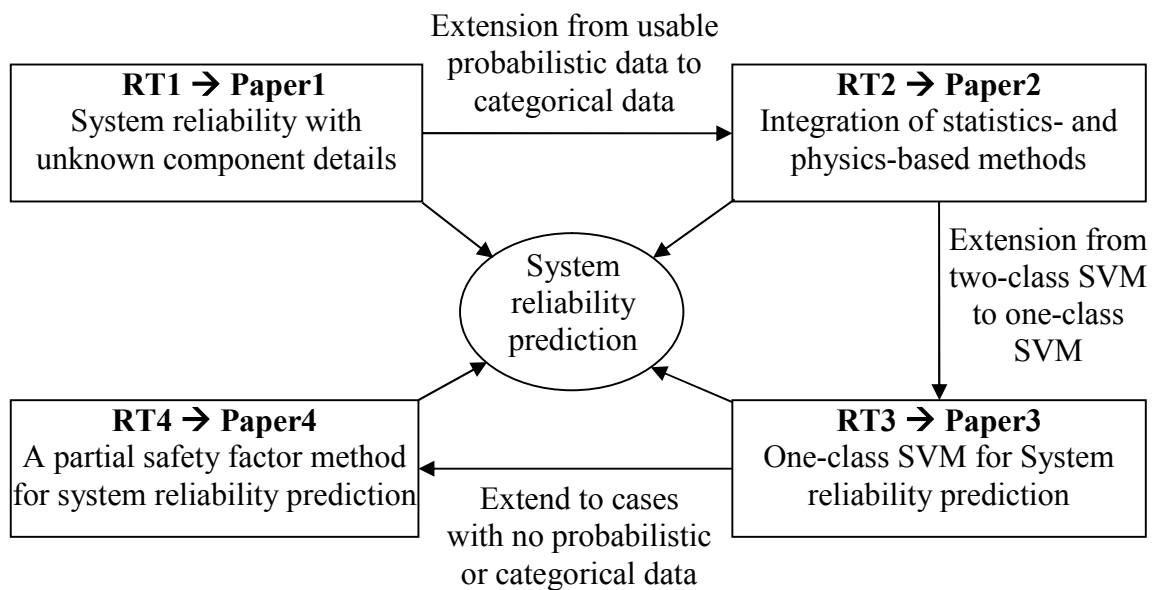

Figure 1.1 Relationship between papers in the dissertation

PAPER

I. SYSTEM RELIABILITY PREDICTION WITH SHARED LOAD AND UNKNOWN COMPONENT DESIGN DETAILS

Zhengwei Hu, Xiaoping Du

Department of Mechanical and Aerospace Engineering

Missouri University of Science and Technology

ABSTRACT

In many system designs, it is a challenging task for system designers to predict the system reliability due to limited information about component designs, which is often proprietary to component suppliers. This research addresses this issue by considering the following situation: all the components share the same system load, and system designers know component reliabilities with respect to the component load, but do not know other information, such as component limit-state functions. The strategy is to reconstruct the equivalent component limit-state functions during the system design stage such that they can accurately reproduce component reliabilities. Since the system load is a common factor shared by all the reconstructed component limit-state functions, the component dependence can be captured implicitly. As a result, more accurate system reliability can be produced compared with traditional methods. An engineering example demonstrates the feasibility of the new system reliability method.

1. INTRODUCTION

In the early design stage of an engineering system, it is important to consider the reliability of the system under design. Reliability is usually quantified as the probability that a system performs its intended function without failures. When generating design concepts, designers not only identify potential solutions that can realize the overall function of the system, but also normally focus on those solutions that may lead to high reliability. After a number of design concepts are generated, best design concepts are selected for further developments in the later design stages. System reliability may be again a focus when design concepts are evaluated and compared. Design concepts with low system reliability are likely to be screened out. It is therefore desirable to accurately predict the system reliability during the system design stage.

Predicting system reliability, however, is difficult because there are many uncertainties and challenges that system designers will face. Some of the challenges are shown below.

- Systems, such as mechanical systems, power systems, and software systems, become more complicated. It is hard to know the explicit statistical relationships between the states of components in a system. This information is often essential for the accurate system reliability analysis.
- Many components of a system are outsourced to outside suppliers. Although this common practice brings larger profits by greatly reducing production costs, it also poses a challenge since system designers may have no access to details of component design [1].

- Without physical prototypes and facilities in the early design stage, it is difficult for system designers to obtain enough experimental information to predict system reliability [2].

In spite of the above challenges, it is possible to predict system reliability approximately with assumptions. For example, if the reliability of each component in the system is available to system designers, they could use the assumption that component states are independent. Then for a given system configuration (series, parallel, or mix), the system reliability is a function of only component reliabilities and can be readily calculated [3, 4]. The assumption, however, may lead to large errors, especially for engineering systems, such as those in mechanical, civil, and aerospace engineering applications. The major reason is that component failures are actually dependent. The state of one component affects those of other components in the system.

Even though components may be designed and manufactured independently by different companies, they become dependent once they operate with other components in the system. For example, all the components may share the same stochastic external load [5] and may be exposed to the same random operating environment. In this case, a failure of any component in the system may affect the states of others.

When components are dependent, the accuracy of the system analysis relies on the complete joint probability distribution of all the component states, and only the marginal distributions of component states (or component reliabilities) are not sufficient. Knowing the joint probability distribution, however, requires that the system designers have all the detailed information about the component designs, such as the limit-state functions, concrete structures, and material properties of the components. But the

information is usually unknown to the system designers and is proprietary to only component designers. To this end, approximations, especially the bounds of system reliability, are used [6, 7]. The common problem is that the difference between the upper and lower reliability bounds is often large. In many cases, the width of system reliability bounds is too large to make any reliable decisions.

Feasibility studies on more accurate system reliability prediction have been recently reported [1, 8]. A physic-based system reliability method [1] allows system designers to obtain narrower system reliability bounds in early design stage by considering dependent components that share the same system load. This method treats unknown distribution parameters of component details as to-be-determined variables or design variables of an optimization model. All information available to system designers, such as component reliabilities, are treated as constraints. Optimization is then used to solve for such unknown variables while maximizing and minimizing the system reliability, thereby producing narrower system reliability bounds. The major contributor to the more accurate system reliability is the consideration of component dependence that is embedded in the system reliability analysis, which is part of the optimization model. It is demonstrated that the narrower system reliability bounds can better assist system designers to make decisions on design concept selection.

The other feasibility study [8] indicates that it is possible to produce a single-valued system reliability prediction, instead of reliability bounds, with more information supplied to system designers by component designers. Given components reliabilities at different load levels, system designers can construct physics-based component and system reliability models using the strength-stress interference theory. With this method,

it is flexible for component designers to generate their component reliability functions with respect to the component load. They could use statistics-based approaches based on field and testing data, and they could also use any physics-based approaches, such as the First Order Reliability Method (FORM), the Second Order Reliability Method (SORM), or the Saddlepoint Approximation Approach [9-14]. Since the component reliabilities are functions of component loads, which are also functions of the stochastic system load, the component reliability functions are statistically dependent. The system reliability model, which depends on the dependent component reliability functions, can therefore account for component dependence and thus produce an accurate system reliability prediction. This work, however, is only a proof-of-concept study, and there are many open questions that need to be answered.

The objective of this research is to realize the concept developed in [8]. More specifically, the objective of this research is to allow system designers to accurately predict system reliability for systems whose components share a stochastic system load. The new developments in this research includes the follows:

(1) Construct component reliability functions with respect to component loads

This task creates a continuous reliability function with respect to the component load for each of the component in the system. The function construction is based on data of component reliabilities, and the data may be discrete or tabulated.

(2) Construct composite component limit-state functions

Without knowing component design details, for each of the components, system designers construct a component limit-state function no matter how many failure modes a

component may have. The reconstructed component limit-state function can accurately predict the state of the component (either a working state or failure state).

(3) Refine the system analysis procedure

Using the component reliability functions, system designers build the system reliability analysis model and obtain the joint probability density function needed for the system reliability analysis. Then the system reliability can be produced.

The rest of this article is organized as follows: Basic concepts and methodologies used in this study are reviewed in Sec. 2. The proposed methodology is discussed in Sec. 4 and is demonstrated with an example in Sec. 4. Conclusion and future work are given in Sec. 5.

2. REVIEW OF SYSTEM RELIABILITY ANALYSIS

System reliability is the probability that a system works properly without failures. The overall system may fail due to the failure of one or more components in the system. In this work, we focus on time-invariant reliability.

2.1 SYSTEM RELIABILITY WITH INDEPENDENT COMPONENT STATES

A series system is shown in Figure 1, in which the components in the system are denoted by C_1, C_2, \dots, C_n . The system will fail if one of its components fails. If all the component failures are independently, the system reliability R_S is

$$R_S = \prod_{i=1}^n R_i \quad (1)$$

where R_i ($i = 1, 2, \dots, n$) is the reliability of component i .

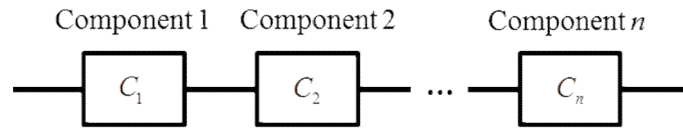

Figure 1 A series system

Component reliability can be estimated by a statistics-based approach with testing or field data. It can also be estimated by a physics-based approach. If the latter approach is used, component reliability is given by

$$R = \Pr\{Y = g(\mathbf{X}) > 0\} \quad (2)$$

where \mathbf{X} is a vector of random input variables, and Y is the state variable. If $Y > 0$, the component functions; otherwise, the component fails.

In this work, we focus on mechanical applications where series systems are usually involved.

2.2 SYSTEM RELIABILITY BOUNDS

Eq. (1) is easy to use, but may produce a large error due to the independent component assumption and may be too conservative. The actual system reliability is bounded as shown [4]

$$\prod_{i=1}^n R_i \leq R_S \leq \min\{R_i\}, \quad i = 1, \dots, n \quad (3)$$

If a mechanical system consists of 20 components with identical component reliabilities $R = 0.999$, Eq. (3) gives the bounds of $0.9802 \leq R_S \leq 0.999$. The bounds

may be too wide to help system designers to compare design concepts for concept selection.

2.3 SYSTEM RELIABILITY WITH COMPONENTS SHARING THE SAME SYSTEM LOAD

To improve system reliability analysis, we performed a preliminary study for systems whose components share the same stochastic system load L [8]. The system designers have good knowledge about L and therefore know the cumulative distribution function (CDF) of L . L is distributed through components, and the component load L_i ($i = 1, 2, \dots, n$) of component i is a function of L . Such a function is assumed to be

$$L_i = w_i L \quad (4)$$

where w_i indicates the fraction of the load that the component shares. w_i can be determined from an system level analysis, such as a force analysis.

System designers request component designers to provide component reliability functions at different component load levels, specified by variable l . The component designers may conduct experiments or use a physics-based approach to calculate component reliability R_i by varying the values of l . Then the component reliability functions $R_i(l)$ are available to system designers.

System designers then assume that the component state could be predicted by the following component limit-state function:

$$g_i(L_i) = Y_i = S_i - L_i = S_i - w_i L \quad (5)$$

where S_i is the general resistance of the component.

The component limit-state function should reproduce the same component reliability; namely,

$$R_i(L_i) = \Pr\{g_i(L_i) > 0\} \quad (6)$$

The probability of system failure is then given by

$$p_{f_s} = \Pr\{S_1 < L_1 \cup S_2 < L_2 \cup \dots \cup S_n < L_n\} = \Pr\left\{\bigcup_{i=1}^n S_i < w_i L\right\} \quad (7)$$

The system reliability is then available and is given by

$$R_s = 1 - p_{f_s} \quad (8)$$

It is obvious that component failure events $S_i < w_i L$ are dependent because of the common random variable L . The component dependence is therefore considered automatically. The reliability function $R_i(l)$ is directly related to the CDF of S_i , because the CDF of S_i is $1 - R_i(l)$ [8]. If S_i and L are independent, system designers know the joint distribution of all the random variables in Eq. (7), thus they can use Eq. (7) to find the system reliability.

3. SYSTEM RELIABILITY ANALYSIS WITH SHARED LOAD AND UNKNOWN COMPONENT DETAILS

The objective of this research is to realize the concept proposed in the feasibility study in [8], which has been reviewed in Sec. 2.3. We now discuss how the concept could be realized with more detailed models and procedures.

We are concerned with systems whose components are provided by outside companies. The system may also have in-house components designed and manufactured by the firm of system designers. This is a common practice, especially in automotive and

defense industries where most of components of a system come from multiple-layer suppliers. The proposed method intends to be used by system designers whose task is to predict the system reliability in the system design stage. The method is applicable for systems with the following features:

- The system load is distributed through all the components. The components are subjected to component loads that are fractions of the system load.
- System designers know the relationship between the system load and component loads through statics, dynamics, stress, or other analyses.
- Component and system failures are primarily due to excessive general loading, such as forces, stresses, deformation, and demand. Component failures can therefore be predicted by limit-state functions defined by the design margin, or the difference between a general resistance (yield strength, allowable deformation, capacity, etc.) and a general load (forces, stress, strain, demand, etc.).

3.1 PROCEDURE OF SYSTEM RELIABILITY PREDICTION

To make system reliability prediction possible, system designers ask component suppliers to provide component reliabilities with respect to their component loads. Since the information of component reliabilities may be in different forms, for system designers, the first step is to formulate component reliability functions $R_i(l)$, $i=1,2,\dots,n$, with respect to the component load l . The second step is to construct composite component limit-state functions $g_i(\cdot)$ based on $R_i(l)$. A composite component limit-state function ensures that it can reproduce accurate component reliability regardless of the number of failure modes the component may have. A composite

component limit-state function does not require any component design details, and thus it prevents the proprietary information of the component supplier. Since the common system load appears in all composite component limit-state functions, the dependence between component states is preserved. This helps improve the accuracy of system reliability prediction. The last step is to perform system reliability analysis. The flowchart indicating the procedure is given in Figure 2.

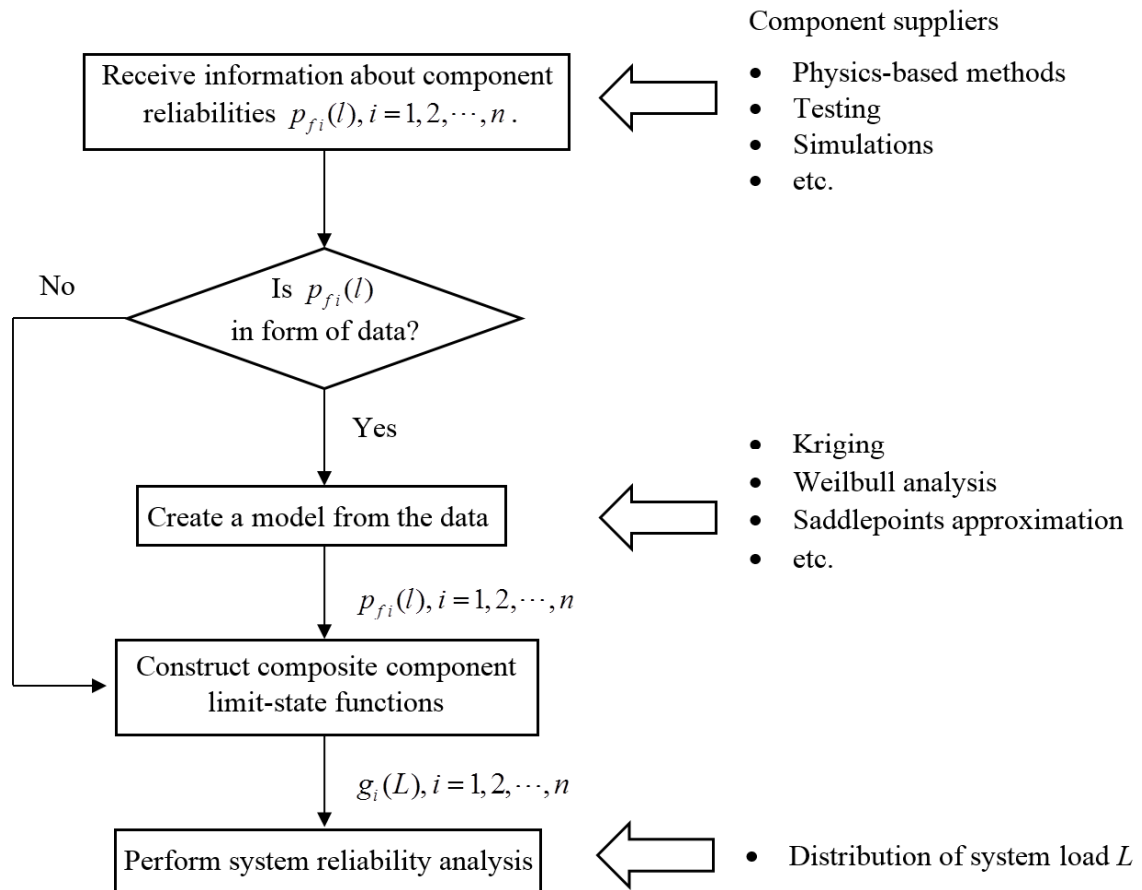

Figure 2 Flowchart of the proposed method

3.2 FORMULATE COMPONENT RELIABILITY FUNCTIONS

Component designers may use different methods to estimate component reliabilities $R_i(l)$, such as using testing, field data, simulations, or a physics-based method. This may result in different forms of information about $R_i(l)$, such as limited reliability data, a scatter plot, or a mathematical model. If no mathematical model exists, system designers need to fit a model from these limited data. As will be discussed in Sec. 3.3, the probability of failure, $p_{fi}(l) = 1 - R_i(l)$, is actually the CDF of the general component resistance. Then, the task becomes to fit a CDF model. Many methods could be used for the CDF fitting such as metamodeling methods, the Saddlepoint approximation (SPA), and the Weibull analysis.

Now we discuss how system designers could fit a CDF model given the limited reliability data. For a general component with probability of failure $p_f(l)$, the available data are given as a set of $(l_j, p_f(l_j))$, $j = 1, 2, \dots, m$. Let the continuous mathematical model be

$$p_f = H(l) \quad (9)$$

Next, we discuss two specific approaches to obtain $H(l)$ from $(l_j, p_f(l_j))$, $j = 1, 2, \dots, m$.

3.2.1 Kriging Method. The Kriging method has been widely used in engineering applications, including reliability analysis [15-17]. The Kriging method considers the mathematical model in Eq. (9) as a realization of a Gaussian process given by [18]

$$p_f(l) = H(l) = \alpha(l)\xi + Z(l) \quad (10)$$

where $\alpha(l)$ is a regression function, and ξ is the regression coefficient. $Z(\cdot)$ is a stationary Gaussian process with zero mean. The covariance between l_i and l_j is

$$\text{Cov}[Z(l_i), Z(l_j)] = \sigma_Z^2 K(l_i, l_j), \quad i = 1, 2, \dots, m; j = 1, 2, \dots, m \quad (11)$$

where σ_Z^2 is the variance of the Gaussian process, and $K(\cdot, \cdot)$ is the correlation function and is commonly defined by the following Gaussian correlation [18, 19]

$$K(l_i, l_j) = \exp[-\theta(l_i - l_j)^2] \quad (12)$$

where θ is a parameter that indicates the correlation between the points. The Best Linear Unbiased Predictor (BLUP) [18] of $H(l)$ gives to a random prediction

$$\hat{p}_f = \hat{H}(l) \sim N(\mu_H(l), \sigma_H^2(l)) \quad (13)$$

where the prediction $\mu_H(\cdot)$ and the associated variance are computed by

$$\mu_H(l) = \alpha(l)\hat{\xi} + \mathbf{r}^T(l)\mathbf{K}^{-1}(\mathbf{p}_f - \mathbf{F}\hat{\xi}) \quad (14)$$

$$\sigma_H^2(l) = \hat{\sigma}_Z^2 \left\{ \begin{array}{l} 1 - [\mathbf{r}(l)]^T \mathbf{K}^{-1} \mathbf{r}(l) \\ + [\mathbf{F}^T \mathbf{K}^{-1} \mathbf{r}(l) - \alpha(l)]^T (\mathbf{F}^T \mathbf{K}^{-1} \mathbf{F})^{-1} \\ [\mathbf{F}^T \mathbf{K}^{-1} \mathbf{r}(l) - \alpha(l)] \end{array} \right\} \quad (15)$$

in which \mathbf{K} is the correlation matrix defined by $\mathbf{K} = [K(l_i, l_j)]$. \mathbf{p}_f is a column vector of responses of current sample points. $\mathbf{r}(\cdot)$ is the vector of cross-correlations between the m samples and the prediction point, $\mathbf{r}(l) = [R(l, l_1), \dots, R(l, l_m)]^T$. \mathbf{F} is a column vector with rows $\alpha(l_i)$, $i = 1, 2, \dots, m$. $\hat{\sigma}_Z^2$ is the Maximum Likelihood Estimation of the process variance

$$\hat{\sigma}_Z^2 = \frac{1}{m} (\mathbf{p}_f - \mathbf{F}\hat{\xi})^T \mathbf{K}^{-1} (\mathbf{p}_f - \mathbf{F}\hat{\xi}) \quad (16)$$

and $\hat{\xi}$ is the generalized least square estimate of ξ

$$\hat{\xi} = [\mathbf{F}^T \mathbf{K}^{-1} \mathbf{F}]^{-1} \mathbf{F}^T \mathbf{K}^{-1} \mathbf{p}_f \quad (17)$$

Substituting Eqs. (14) and (15) into Eq. (13), system designers obtain the reliability mathematical model in the form of $p_f = \hat{H}(l)$ for $p_f = H(l)$ in Eq. (9).

3.2.2 Weibull Method. A Weibull distribution can fit different data and distributions. Due to this advantage, system designers may use a Weibull model to fit the component reliability data. A three-parameter Weibull distribution is given by

$$p_f = H(l) = 1 - \exp\left(-\left(\frac{l-\gamma}{\eta}\right)^\beta\right) \quad (18)$$

in which $l > \gamma, \beta > 0, \eta > 0$. The location parameter γ defines the location of the distribution; β is the shape parameter, and η is the scale parameter.

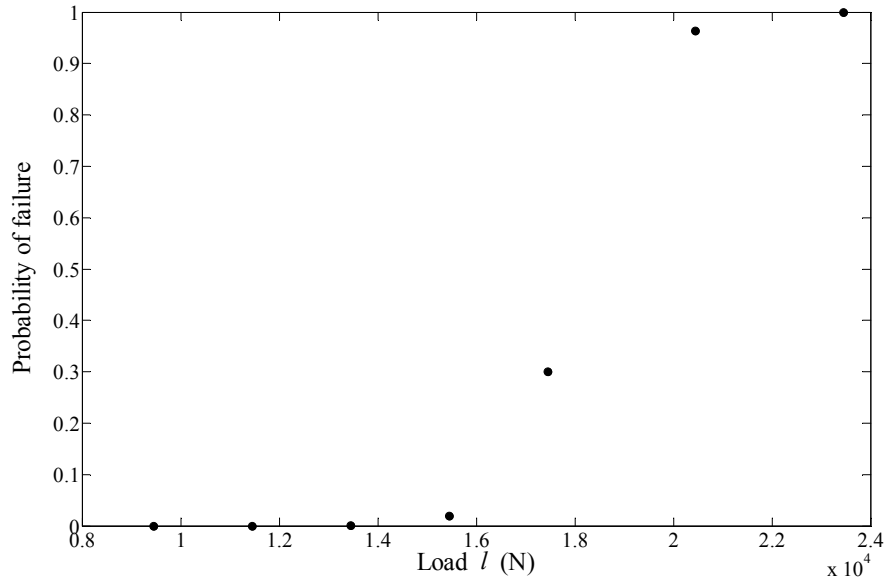

Figure 3 Component reliability data

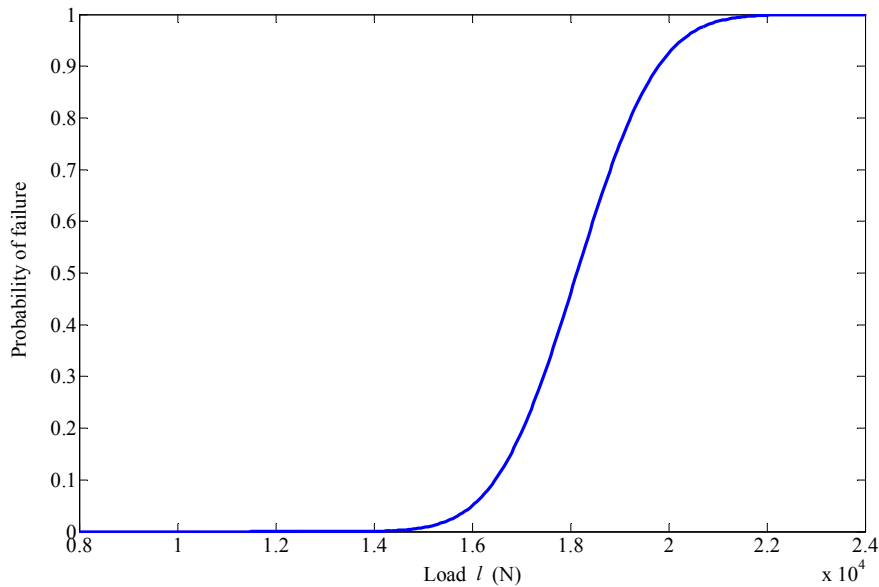

Figure 4 The complete p_f model

For a given set of $(l_j, p_f(l_j))$, $j = 1, 2, \dots, m$, system designers could use the maximum likelihood method [20] to find the three distribution parameters. They could also use a curve fitting method [21] to find the three distribution parameters.

Other regression analysis methods could also be used for the CDF fitting. One example showing the CDF fitting follows. Suppose the probabilities of component failure p_f at seven load levels are given and are shown in Figure 3. A mathematical model of p_f with respect to the component load l can be then fitted as shown in Figure 4.

3.3 RECONSTRUCT COMPONENT LIMIT-STATE FUNCTIONS

The next task of system designers is to reconstruct component limit-state functions, which should meet the following requirements:

- Do not require component design details
- Maintain dependence between component states
- Be functions of the system load and easy to evaluate
- Accommodate multiple component failure modes

Based on these requirements, for the i -th component, system designers reconstruct the limit-state function in the form of

$$Y_i = S_i - L \quad (19)$$

where S_i is the general component resistance, and L is the system load. Note that no matter how many failure modes the component may have, there is only one reconstructed component limit-state function as shown in Eq. (19).

Although the reconstructed component limit-state function is linear with respect to L , it can accommodate the situation where the actual component limit-state function is nonlinear with respect to L . One example follows. Let the yield strength of the i -th component be S_y . If the maximum stress is $h(L)$, where $h(\cdot)$ is a nonlinear function, also depending on other component parameters, such as dimensions, and then component designers build their limit-state function as

$$Y'_i = S_y - h(L) \quad (20)$$

Theoretically, they can solve for L by letting $S_y - h(L) = 0$ at the limit state and obtain

$$L = h^{-1}(S_y) \quad (21)$$

where $h^{-1}(\cdot)$ is the inverse function of $h(\cdot)$.

Then the limit-state function is modified as

$$Y_i = h^{-1}(S_y) - L \quad (22)$$

Let $S_i = h^{-1}(S_y)$, which is regarded as the general component resistance. Then Eq. (22) is exactly the one reconstructed by system designers in Eq. (19). This indicates that the reconstruct component limit-state functions do cover actual component limit-state functions that are nonlinear with respect to the system load.

Before explaining the procedure of reconstructing the composite limit-state function, we first prove that the probability of component failure $p_{fi}(l)$ is the CDF of the general component resistance S_i . According to Eq. (19), for a constant l ,

$$p_{fi}(l) = \Pr(S_i < l) \quad (23)$$

The CDF of S_i is defined by

$$F_{S_i}(s) = \Pr(S_i < s) \quad (24)$$

Replacing l with s in Eq. (23), we have $p_{fi}(s) = \Pr(S_i < s)$. As a result,

$$F_{S_i}(s) = p_{fi}(s) = 1 - R_i(s) \quad (25)$$

Since system designers know the component reliability function $R_i(l)$ or probability of component failure $p_{fi}(l)$, they also know the CDF of the general component resistance S_i .

The composite component limit-state function is not only a simple (linear) function, it also safeguards the proprietary information of component designers. Next, let us look at the component design of the example that will be presented in Sec.4.

In the example, Component 2 has two failure modes due to excessive normal stress and excessive shear stress. The component designer decide to use a physics-based

approach to evaluate the component reliability. The limit-state function of the two failure modes are given by

$$Y_{21} = S_y - \frac{(h + H_1) L}{W_x} \frac{L}{2} \quad (26)$$

$$Y_{22} = \tau - \frac{1}{hb} \frac{L}{2} \quad (27)$$

in which $L/2$ is the load shared by the component. h , H_1 , W_x , and b are random parameters related to component details. The two limit-state functions indicated that component details are required for the component reliability analysis. The details include material properties, component structure, and component dimensions.

The two limit-state functions for the two failure modes can be rewritten as

$$Y'_{21} = \frac{2W_x S_y}{h + H_1} - L = S_{21} - L \quad (28)$$

$$Y'_{22} = 2\tau hb - L = S_{22} - L \quad (29)$$

in which $S_{21} = \frac{2W_x S_y}{h + H_1}$ and $S_{22} = 2\tau hb$. Then, the probability of component failure is

$$p_{f2} = \Pr\{S_{21} < L \cup S_{22} < L\} = \Pr\{\min(S_{21}, S_{22}) < L\} = \Pr\{S_2 < L\} \quad (30)$$

where $S_2 = \min(S_{21}, S_{22})$ is the general component resistance in Eq. (19). Note that, the details such as h , H_1 , W_x , and b in Eqs. (26) through (29) are only known to component designers who could find the component probabilities of failure at different load levels of load l_i ($i = 1, 2, \dots, n$) by testing or using a physics-based reliability approach. Then the results could be provided to the system designers in the form of $(p_{f2}(l_i), l_i)$. As discussed in Eqs. (24) and (25), the probability of component failure p_{f2}

is exactly the CDF of the general component resistance S_2 . Thus, the distribution of S_2 is known to system designers, and with this distribution, they no longer need any design details. No proprietary information is therefore required. Eq. (19) also indicates that the system load L appears in all the reconstructed component limit-state functions, and the dependence between component states is automatically maintained. Meanwhile, the composite limit-state function takes into account the multiple component failure modes, and it has a simple expression to evaluate. Thus, the obtained composite limit-state functions satisfy all the requirements mentioned above.

3.4 SYSTEM RELIABILITY ANALYSIS

We now discuss how system designers use the reconstructed composite component limit-state functions in Eq. (19) to predict system reliability. The probability of system failure is given by

$$p_{fs} = \Pr \left\{ \bigcup_{i=1}^n Y_i = S_i - L < 0 \right\} \quad (31)$$

The prerequisite for calculating p_{fs} is to find the joint probability distribution of S_i ($i=1,2,\dots,n$) and L . We now discuss how to obtain such a joint probability distribution.

Denote the $n+1$ input random variables by $\mathbf{Z} = (S_1, S_2, \dots, S_n, L)$ and all the output variables by $\mathbf{Y} = (Y_1, Y_2, \dots, Y_n)$. As discussed in Sec. 3.3, the general component resistances S_i ($i=1,2,\dots,n$) are determined by component material properties, concrete component structures, geometric dimensions, and other component parameters. Since all

the components are independently designed, manufactured, and tested by different suppliers, their general resistances are likely statistically independent. The system load L is also independent from the general component resistances. Thus, all the components in \mathbf{Z} are independent.

Denote the CDF of S_i and L by $F_{S_i}(s_i)$, and $F_L(l)$, respectively. The joint CDF of \mathbf{Z} is then given by

$$F_{\mathbf{Z}}(\mathbf{z}) = F_L(l) \prod_{i=1}^n F_{S_i}(s_i) \quad (32)$$

where $\mathbf{z} = (s_1, s_2, \dots, s_n, l)$. Since system designers know CDFs of S_i and L , it is ready for them to predict the probability of system failure. Denote the joint Probability Density Function (PDF) of \mathbf{Z} by $f_{\mathbf{Z}}(\mathbf{z})$. Then the probability of system failure is computed by

$$p_{fs} = \int_{\Omega} f_{\mathbf{Z}}(\mathbf{z}) d\mathbf{z} \quad (33)$$

where Ω is the system failure region defined by

$$\Omega = \{\mathbf{Z} \mid S_i < L, i = 1, 2, \dots, n\} \quad (34)$$

where p_{fs} can be calculated by an numerical integration or Monte Carlo Simulation.

Next, we demonstrate this with two special cases.

In the first case, the components S_i ($i = 1, 2, \dots, n$) of $\mathbf{Z} = (S_1, S_2, \dots, S_n, L)$ follow Weibull distributions, while L follows a distribution with PDF $f_L(l)$. Note that $Y_i = S_i - L$, thus Y_1, Y_2, \dots, Y_n are dependent. Since the distribution parameters of \mathbf{Y} are unknown, it is unable to directly find p_{fs} using Eq. (31). However, as we know that S_1, S_2, \dots, S_n , and L are independent, the joint PDF of \mathbf{Z} could be calculated by

$$f_{\mathbf{Z}}(\mathbf{z}) = f_{\mathbf{Z}}(s_1, s_2, \dots, s_n, l) = f_L(l) \prod_{i=1}^n \left[\frac{\beta_i}{\eta_i} \left(\frac{s_i - \gamma_i}{\eta_i} \right)^{\beta_i - 1} \exp \left(- \left(\frac{s_i - \gamma_i}{\eta_i} \right)^{\beta_i} \right) \right] \quad (35)$$

Then, according to Eq. (33), by integrating the joint PDF $f_{\mathbf{Z}}(\mathbf{z})$ in Eq. (35) in the failure region Ω defined in Eq. (34), system designers can obtain the probability of system failure.

In case two, the components of $\mathbf{Z} = (S_1, S_2, \dots, S_n, L)$ are normally distributed. From Eq. (31), the distribution of the reconstructed component limit-state function is $Y_i \sim N(\mu_{Y_i}, \sigma_{Y_i}^2)$ with $\mu_{Y_i} = \mu_{S_i} - \mu_L$, and $\sigma_{Y_i} = \sqrt{\sigma_{S_i}^2 + \sigma_L^2}$, in which μ_L and σ_L are the mean and standard deviation of L . All the reconstructed limit-state functions $\mathbf{Y} = (Y_1, Y_2, \dots, Y_n)$ then follow a multivariate normal distribution determined by the following mean vector and covariance matrix.

$$\boldsymbol{\mu} = (\mu_{S_1} - \mu_L, \mu_{S_2} - \mu_L, \dots, \mu_{S_n} - \mu_L) \quad (36)$$

$$\boldsymbol{\Sigma} = \begin{bmatrix} \sigma_{Y_1}^2 & \text{cov}(Y_1, Y_2) & \cdots & \text{cov}(Y_1, Y_n) \\ \text{cov}(Y_2, Y_1) & \sigma_{Y_2}^2 & & \text{cov}(Y_2, Y_n) \\ \vdots & \vdots & \ddots & \vdots \\ \text{cov}(Y_n, Y_1) & \text{cov}(Y_n, Y_2) & \cdots & \sigma_{Y_n}^2 \end{bmatrix} \quad (37)$$

in which $\text{cov}(Y_i, Y_j) = \sigma_L^2$. For this special case, since the distribution parameters of \mathbf{Y} could be easily derived, it is more convenient to find p_{f_s} using the PDF of \mathbf{Y} , which is given by

$$f_{\mathbf{Y}}(\mathbf{y}) = \frac{1}{\sqrt{(2\pi)^n |\boldsymbol{\Sigma}|}} \exp \left(- \frac{1}{2} (\mathbf{y} - \boldsymbol{\mu})^T \boldsymbol{\Sigma}^{-1} (\mathbf{y} - \boldsymbol{\mu}) \right) \quad (38)$$

Then p_{f_s} is easily obtained by integrating Eq. (38) in the failure region $\{\mathbf{Y} | \mathbf{Y} < \mathbf{0}\}$.

4. EXAMPLE

In this section, an engineering example is used to show the procedure of the proposed method and demonstrate its feasibility and accuracy.

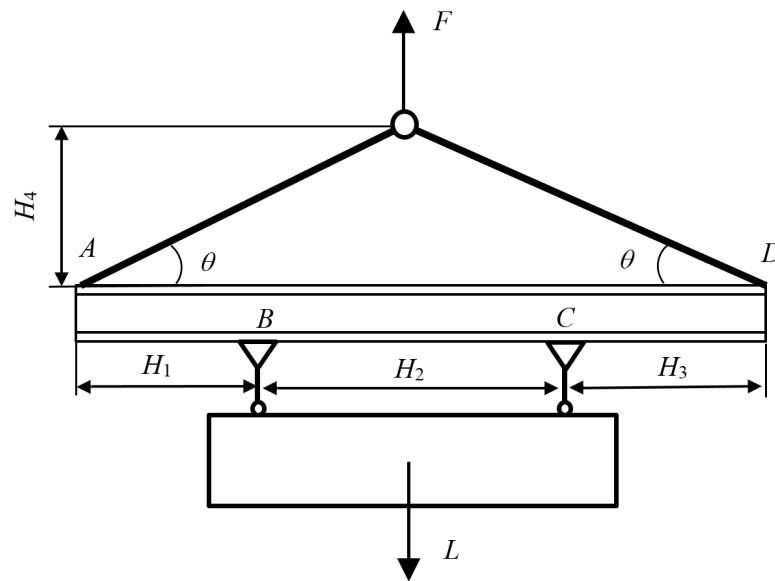

Figure 5 Lifting system

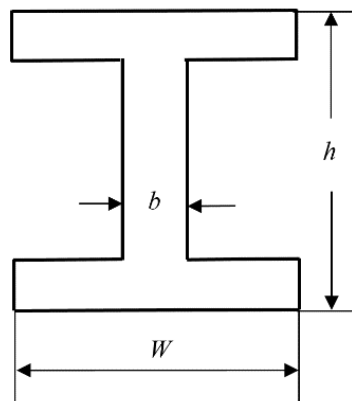

Figure 6 Cross-section of the spreader beam

A lifting system, as shown in Figures 5 and 6, consists of two components from different suppliers: one cable (Component 1) from Company 1, and one spreader beam (Component 2) from Company 2.

Company 1 designs the cable with a diameter d and an allowable tensile stress S_{a1} as shown in Table 1. The designers of Component 1 also evaluate the reliability of the cable with respect to different component load levels. They could obtain the component reliability using either a physic-based reliability method or by testing. If a physic-based reliability method is used, the limit-state function is given by

$$Y_{11} = S_{a1} - \frac{L_1}{2 \sin \theta} \quad (39)$$

in which L_1 is the component load. Component designers calculate the probabilities of component failure $p_{f1}(l)$ by replacing L_1 with different load levels, denoted by l_1 . Eq. (39) is then given by

$$p_{f1}(l_1) = \Pr \left\{ Y_{11} = S_{a1} - \frac{l_1}{2 \sin \theta} < 0 \right\} \quad (40)$$

Note that l_1 is a deterministic variable in the component reliability analysis.

Table 1 Detailed information of Component 1

Variable	Mean	Standard deviation	Distribution
d (in)	0.96	1×10^{-3}	Normal
S_{a1} (psi)	28×10^3	2×10^3	Normal

Component designers then provide the results to system designers, and the results are given in Table 2. The reliability results may also be generated by testing at the same load levels.

Table 2 Reliability data of Component 1

No.	p_{f1}	l_1 (lb)
1	0	11450
2	4×10^{-6}	12450
3	1.527×10^{-4}	13450
4	0.0022	14450
5	0.0193	15450
6	0.0976	16450
7	0.3004	17450
8	0.5982	18450
9	0.8460	19450
10	0.9635	20450
11	0.9949	21450
12	0.9996	22450
13	1.0000	23450

At Company 2, the designers decide to use a W12×40 beam, as shown in Figure 6. They know the allowable normal and shear stresses of the beam, denoted by S_{a2} and τ_{a2} , respectively. The design details are shown in Table 3. There are two failure modes caused by excessive normal and excessive shear stresses. The associated limit-state functions are then given by

$$Y_{21} = S_{a21} - \frac{L_2(h + H_1)}{2W_x} \quad (41)$$

$$Y_{22} = \tau_{a2} - \frac{L_2}{2hb} \quad (42)$$

The component designers perform reliability analysis and supply their results in Table 4 to system designers.

Table 3 Detailed information of Component 2

Variable	Mean	Standard deviation	Distribution
b (in)	0.2	1×10^{-3}	Normal
W_x (in ³)	51.9	1.5	Normal
S_{a21} (psi)	30×10^3	2×10^3	Normal
τ_{a2} (psi)	6×10^3	1×10^3	Normal
h (in)	11.94	--	--
W (in)	8.005	--	--
H_1 (ft)	2.5	--	--
H_2 (ft)	15	--	--
H_3 (ft)	2.5	--	--
H_4 (ft)	5	--	--

Note that neither Component 1 designers nor Component 2 designers need to know the system load L . Only component loads are needed at the component design

level. The component load values are treated as deterministic, and this makes component reliability analysis easier.

Table 4 Reliability data of Component 2

No.	P_{f2}	l_2 (lb)
1	1.667×10^{-6}	6000
2	4×10^{-6}	7000
3	1.033×10^{-5}	8000
4	2.100×10^{-5}	9000
5	4.933×10^{-5}	10000
6	1.127×10^{-4}	11000
7	2.430×10^{-4}	12000
8	5.633×10^{-4}	13000
9	0.0020	14000
10	0.0123	15000
11	0.0675	16000
12	0.2353	17000
13	0.5191	18000
14	0.7909	19000
15	0.9405	20000
16	0.9893	21000
17	0.9988	22000
18	0.9999	23000
19	1.0000	24000

Now let us discuss how system designers use component reliability functions to predict the system reliability. To make the numerical analysis robust, system designers may add more data points to the probabilities of component failure. For example, for

Component 1, the data from company 1 show that when $l_1 = 11450$ lb, $p_{f1} = 0$. If the component load is less than 11450 lb, p_{f1} will therefore be 0. System designers then add two more points (9450,0) and (10450,0) where the first element denotes the load, and the second element denotes the probability of failure. When the load is greater than 23450 lb, p_{f1} will be 1. System designers also add two other data points (24450,1) and (25450,1). For the same reason, they also add one data point (25000,1) for Component 2. Adding more data points makes the CDF fitting more robust.

All the information that the system designers know is shown in Table 5, including the limited component reliability data provided by component 1 and 2 designers, added data points, and the distribution of the system load.

Table 5 Information available to system designers

Known information	Value
Reliability data of Component 1	Table 2 and added points
Reliability data of Component 2	Table 4 and added points
Distribution of system load L	$N\left(1.2 \times 10^4, (1.2 \times 10^3)^2\right)$ lb

To predict the system reliability, system designers first fit the CDFs of component resistances with the Kriging method. The results are shown in Figures 7 and 8. Then they reconstruct two composite component limit-state functions as

$$Y_1 = S_1 - L \quad (43)$$

$$Y_2 = S_2 - L \quad (44)$$

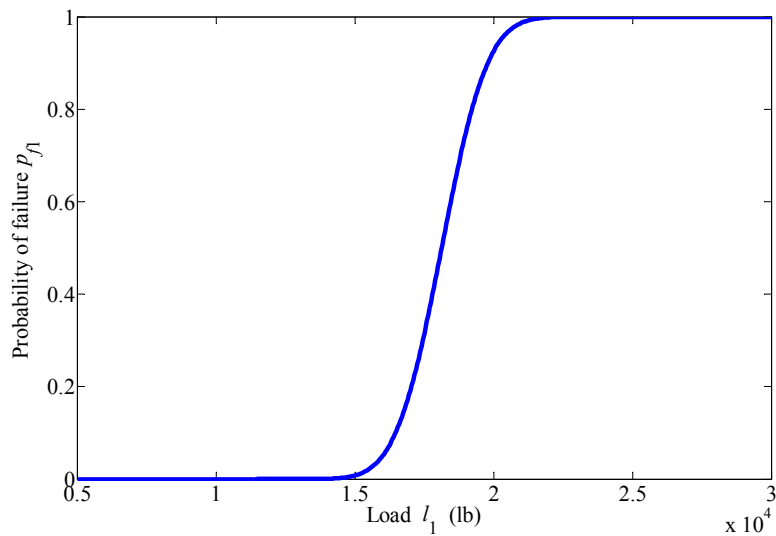

Figure 7 Fitted probability of failure for Component 1

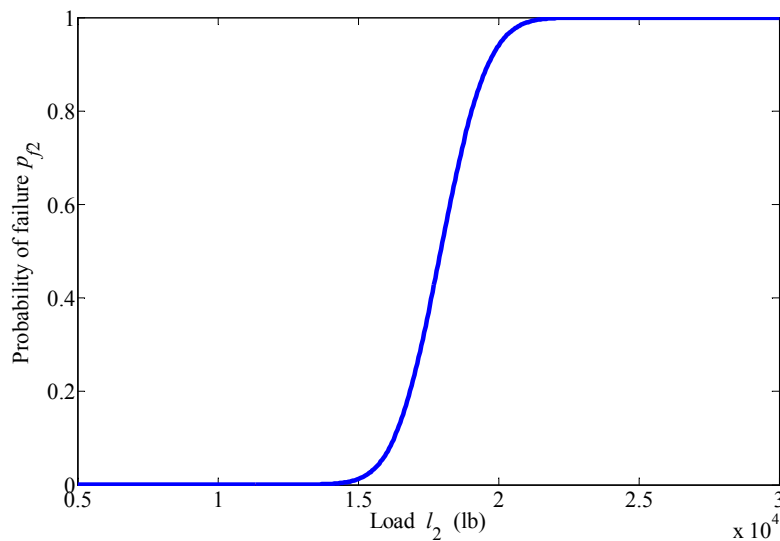

Figure 8 Fitted probability of failure for Component 2

Finally, the probability of system failure is evaluated by Eq. (45) using MCS. Other physics-based reliability methods, such as FORM or SAP, can also be used.

$$p_{fs} = \Pr\{Y_1 < 0 \cup Y_2 < 0\} \quad (45)$$

The results of the probabilities of failure of Component 1 (p_{f1}), Component 2 (p_{f2}) and system (p_{fs}) generated by system designers are shown in Table 6.

Table 6 Results of system reliability prediction

	Proposed Method	True value	Error (%)
p_{f1}	1.603×10^{-4}	1.612×10^{-4}	0.56
p_{f2}	5.348×10^{-4}	5.28×10^{-4}	1.29
p_{fs}	6.9767×10^{-4}	6.862×10^{-4}	0.8

To evaluate the accuracy of the proposed method, we use MCS to find the true probability of system failure as if everything was known at the system analysis level. The complete information includes the three original limit-state functions in Eqs. (39), (41) and (42); and the distributions of all the design variables and the system load. The true result is shown as “True value” in Table 6. The results indicate that the proposed method leads to an accurate probability of system failure, and the error is only 0.8%.

5. CONCLUSIONS

Accurately predicting system reliability in the design stage is a challenging task, and one of the major challenges is to incorporate statistical dependence between

components in the system reliability analysis. Previous concept-proof studies have demonstrated the feasibility of improving the accuracy of system reliability prediction by considering component dependence through a shared system load, and this work develops a methodology to realize the concept.

The proposed work is intended to be used by system designers and is applicable to series mechanical systems with components that share a stochastic system load. The components may be designed and manufactured by independent outside suppliers. The detailed information about component design is not available to system designers. As a result, the statistical component dependence is unknown to system designers even though they have access to component reliabilities.

The requirement of the present method is the component reliability function with respect to the component load. System designers therefore need to request information about component reliability with respect to the component load and then use the information to generate the component reliability function. After this, the proposed method helps system designers construct composite component limit-state functions that can not only reproduce the same component reliabilities but also incorporate component dependence automatically. As a result, system designers can accurately predict system reliability without knowing proprietary information about component design.

The present method is limited to systems with components whose failures are caused by excessive loads (stresses, deformation, etc.). It is also limited to applications where only one system load is applied. The method could be extended to multiple system loads in the future work. Other future research directions include the application to

parallel systems and mix systems, accommodation of time-dependent failures, and consideration of non-strength failure modes.

ACKNOWLEDGEMENTS

The authors are grateful for the support from the National Science Foundation through grants CMMI 1234855 and CMMI 1300870 and CMMI 1562593.

REFERENCES

- [1] Cheng, Y., and Du, X., 2016, "System Reliability Analysis With Dependent Component Failures During Early Design Stage—A Feasibility Study," *Journal of Mechanical Design*, 138(5), p. 051405.
- [2] Ormon, S. W., Cassady, C. R., and Greenwood, A. G., 2002, "Reliability prediction models to support conceptual design," *IEEE Transactions on Reliability*, 51(2), pp. 151-157.
- [3] Dhingra, A. K., 1992, "Optimal apportionment of reliability and redundancy in series systems under multiple objectives," *IEEE Transactions on reliability*, 41(4), pp. 576-582.
- [4] Arnljot, H., and Rausand, M., 2009, *System Reliability Theory: Models and Statistical Methods*, John Wiley & Sons.
- [5] Pozsgai, P., Neher, W., and Bertsche, B., "Models to consider load-sharing in reliability calculation and simulation of systems consisting of mechanical components," *Proc. Reliability and Maintainability Symposium*, 2003. Annual, IEEE, pp. 493-499.
- [6] Ditlevsen, O., 1979, "Narrow reliability bounds for structural systems," *Journal of structural mechanics*, 7(4), pp. 453-472.
- [7] Zhang, Y. C., 1993, "High-order reliability bounds for series systems and application to structural systems," *Computers & Structures*, 46(2), pp. 381-386.
- [8] Hu, Z., and Du, X., "A physics-based reliability method for components adopted in new series systems," *Proc. Reliability and Maintainability Symposium (RAMS)*, 2016 Annual, IEEE, pp. 1-7.

- [9] Dolinski, K., 1982, "First-order second-moment approximation in reliability of structural systems: critical review and alternative approach," *Structural Safety*, 1(3), pp. 211-231.
- [10] Hohenbichler, M., and Rackwitz, R., 1982, "First-order concepts in system reliability," *Structural safety*, 1(3), pp. 177-188.
- [11] Cai, G., and Elishakoff, I., 1994, "Refined second-order reliability analysis," *Structural Safety*, 14(4), pp. 267-276.
- [12] Du, X., and Chen, W., 2000, "Methodology for managing the effect of uncertainty in simulation-based design," *AIAA journal*, 38(8), pp. 1471-1478.
- [13] Du, X., and Sudjianto, A., 2004, "First order saddlepoint approximation for reliability analysis," *AIAA journal*, 42(6), pp. 1199-1207.
- [14] Dilip, D. M., Ravi, P., and Babu, G. S., 2013, "System reliability analysis of flexible pavements," *Journal of Transportation Engineering*, 139(10), pp. 1001-1009.
- [15] Kleijnen, J. P., 2009, "Kriging metamodeling in simulation: A review," *European journal of operational research*, 192(3), pp. 707-716.
- [16] Viana, F., and Haftka, R., "Probability of Failure Uncertainty Quantification with Kriging," *Proc. 53rd AIAA/ASME/ASCE/AHS/ASC Structures, Structural Dynamics and Materials Conference 20th AIAA/ASME/AHS Adaptive Structures Conference 14th AIAA*, p. 1853.
- [17] Kolios, A. J., and Salonitis, K., 2013, "Surrogate modelling for reliability assessment of cutting tools."
- [18] Sacks, J., Welch, W. J., Mitchell, T. J., and Wynn, H. P., 1989, "Design and analysis of computer experiments," *Statistical science*, pp. 409-423.
- [19] Lophaven, S., Nielsen, H., and Sondergaard, J., 2002, "DACE: A Matlab Kriging Toolbox. 2002," *Technical University of Denmark*.
- [20] Lockhart, R. A., and Stephens, M. A., 1994, "Estimation and tests of fit for the three-parameter Weibull distribution," *Journal of the Royal Statistical Society. Series B (Methodological)*, pp. 491-500.
- [21] Hamming, R., 2012, *Numerical methods for scientists and engineers*, Courier Corporation.

II. INTEGRATION OF STATISTICS- AND PHYSICS-BASED METHODS – A FEASIBILITY STUDY ON ACCURATE SYSTEM RELIABILITY PREDICTION

Zhengwei Hu and Xiaoping Du

Department of Mechanical and Aerospace Engineering

Missouri University of Science and Technology

ABSTRACT

Component reliability can be estimated by either statistics-based methods with data or physics-based methods with models. Both types of methods are usually independently applied, making it difficult to estimate the joint probability density of component states, which is a necessity for an accurate system reliability prediction. The objective of this study is to investigate the feasibility of integrating statistics- and physics-based methods for system reliability analysis. The proposed method employs the first-order reliability method directly for a component whose reliability is estimated by a physics-based method. For a component whose reliability is estimated by a statistics-based method, the proposed method applies a supervised learning strategy through Support Vector Machines to infer a linear limit-state function that reveals the relationship between component states and basic random variables. With the integration of statistics- and physics-based methods, the limit-state functions of all the components in the system will then be available. As a result, it is possible to predict the system reliability accurately with all the limit-state functions obtained from both physics- and statistics-based reliability methods.

1. INTRODUCTION

System reliability can be numerically measured by the probability that the system performs its intended function without failures. As the system state (safe or failed) is determined by the states of its components and it is hard to predict the system reliability directly, the system reliability is usually estimated based on component states. The accurate system reliability prediction requires the joint probability density of component states [1].

A physical component itself can be considered as a system since it may have multiple failure modes, and the reliability of the physical component is determined by the states of all the component failures. For this reason, we also consider a failure mode as a component and a physical component as a system if it has multiple failure modes.

Statistics-based methods [2] and physics-based methods [3] are two possible choices for component reliability analysis. A statistics-based method relies on field or testing data related to failures of a component. In this study, we consider only static reliability that does not change over time, which means the reliability estimation does not involve time. Physics-based reliability methods use a limit-state function, which is derived from physics principles, to predict the state of a component failure mode. The limit-state function is usually denoted by $y = g(\mathbf{X})$, where \mathbf{X} is a vector of basic random variables, and y is the state variable. If $y < 0$, the state is failed. Then the probability of failure p_f with respect to this failure mode is given by

$$p_f = \Pr \{ \text{state} = \text{failed} \} = \Pr \{ y = g(\mathbf{X}) < 0 \} \quad (1)$$

Since there is rarely a closed-form solution to Eq. (1), many approximation methods have been developed, such as the First Order Reliability Method (FORM) [4], the Second Order Reliability Method (SORM) [5], the Saddlepoint Approximation method (SPA) [6], Monte Carlo Simulation (MCS) [7], and Matrix-based System Reliability (MSR) method [8]. Numerous applications of these methods have been reported for many systems, such as mechanical, automation, and communication systems.

If the limit-state functions for all the failure modes of the components in the system are available, it is possible to estimate the system reliability for a given system configuration (series, parallel, mixed, and network). Next we take a series system as an example because it is commonly encountered in mechanical applications. If one failure mode occurs or one component fails, the entire system will fail. Suppose the system consists of multiple components and there are totally m failure modes with each denoted by P_i ($i=1,2,\dots,m$), where P_i stands for failure event $g_i(\mathbf{X}) < 0$, and $g_i(\cdot)$ is the limit-state function for the i -th failure mode. Then the probability of system failure is computed by

$$p_{fs} = \Pr\left(\bigcup_{i=1}^m P_i\right) = \Pr\left(\bigcup_{i=1}^m y_i = g_i(\mathbf{X}) < 0\right) \quad (2)$$

Eq. (2) requires the joint distribution of y_i ($i=1,2,\dots,m$), but it is difficult to obtain such a joint distribution, which requires all the details about $g_i(\mathbf{X})$ and the dependency between components. As a result, the independence assumption is widely used in practice [9], where all the component states are assumed to be independent. For the above series system, the system reliability is calculated by

$$R_s = \prod_{i=1}^m R_i \quad (3)$$

Although this method is easy to use, its result may be far smaller than the true value. Without the complete joint probability distribution of component states, it is difficult to evaluate system reliability accurately, especially when component reliabilities are estimated by statistics- and physics-based methods independently.

Recently, Hu and Du [10, 11] proposed a new method that reconstructs component limit-state functions with limited reliability information, making it possible to evaluate system reliability using MCS. The method is effective for cases where component reliability data are provided with respect to system loads. A proof-of-concept method has also recently been proposed for systems with both in-house and outsourced components [12], where the reliabilities of in-house components are estimated with physics-based methods and those of the outsourced ones with statistics-based methods. The study has shown the feasibility of integrating statistics- and physics-based reliability approaches for special problems. The objective of this work is to further investigate the method proposed in [12]. For the statistics-based methods, samples of basic variables (loading, material properties, dimensions, etc.) and the component states, either safe or failed, are available. We adopt Support Vector Machines (SVM) to build linear limit-state functions with respect to the basic variables since SVM is one of the best classification methods due to its high efficiency and accuracy. It has also been employed in many studies [13, 14]. Then, with the limit-state functions generated by SVM and those from physics-based methods, the system reliability could be accurately estimated.

The scope and assumptions of the new method are as follows: Components fail due to excessive loads. For components whose reliability is estimated by a statistics-based method, observations of basic random variables are available. Distributions of all

basic random variables are known. The study focuses on series systems although it can be extended to parallel systems.

The proposed method has the following advantages: 1) Limit-state functions built from statistical data can be easily integrated with those derived from physics. This helps system designers understand the dependency between component failures and enables them to construct a complete joint distribution of component states. 2) The proposed method does not restrict the number of basic random variables (such as loads) shared by components. Hence it has a broader application scope than the previously proposed methods [10, 11] that can accommodate only one common system load.

A brief review of SVM and First Order Reliability Method is given in Section 2. In Section 3, the SVM method for building limit-state functions and the procedure of system reliability analysis with the proposed method are introduced. Three examples are discussed in Section 4. Conclusions and future work are presented in Section 5.

2. METHODOLOGY REVIEW

In this work, we use FORM for physics-based component reliability analysis and use SVM to construct limit-state functions for failure modes (components) whose reliabilities are estimated by a statistics-based method. Both methods are reviewed below.

2.1 SUPPORT VECTOR MACHINE (SVM)

Given a set of training points

$$(\mathbf{x}_1, y_1), (\mathbf{x}_2, y_2), \dots, (\mathbf{x}_k, y_k), \quad \mathbf{x} \in R^n, \quad y \in (+1, -1) \quad (4)$$

in which \mathbf{x}_i is a training point, and y is the class label for \mathbf{x}_i . Note that $\mathbf{x}_i = (x_{i1}, x_{i2}, \dots, x_{in})$ ($i = 1, 2, \dots, k$) is an n -dimensional row vector. The value of y depends on whether the point belongs to the first class or the second one. In this work, if the point falls in the safe region, then $y = +1$; otherwise, $y = -1$. The objective of SVM is to separate the training points into two classes with a hyperplane, as shown in Figure 1, which is given by

$$\boldsymbol{\omega}\mathbf{X}^T + b = 0 \quad (5)$$

where $\boldsymbol{\omega}$ is a weight vector, and b is the bias. The shaded points passed by these hyperplanes are called support vectors, and there are no points between these hyperplanes.

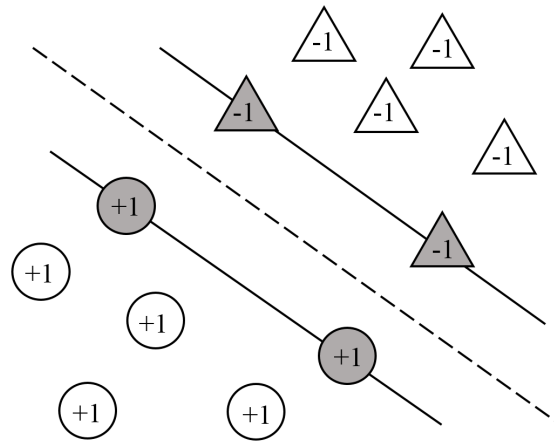

Figure 1 Marginal classifiers along with support vectors

The optimal separating hyperplane appears in the center and can be obtained by solving the following quadratic optimal problem:

$$\begin{cases} \min_{\boldsymbol{\omega}} \frac{1}{2} \boldsymbol{\omega} \boldsymbol{\omega}^T \\ \text{s.t. } y_i (\boldsymbol{\omega} \mathbf{x}_i^T + b) \geq 1, (i=1, 2, \dots, k) \end{cases} \quad (6)$$

It can be converted into a dual problem according to the Lagrange principle and is given by

$$\begin{cases} \max_{\boldsymbol{\lambda}} L = \sum_{i=1}^k \lambda_i - \frac{1}{2} \sum_{i=1, j=1}^k \lambda_i \lambda_j y_i y_j \mathbf{x}_i \mathbf{x}_j^T \\ \text{s.t. } \sum_{i=1}^k y_i \lambda_i = 0, \lambda_i \geq 0, (i=1, 2, \dots, k) \end{cases} \quad (7)$$

where $\boldsymbol{\lambda} = (\lambda_1, \lambda_2, \dots, \lambda_k)$ are the Lagrange multipliers. The weight vector is then calculated by

$$\boldsymbol{\omega} = \sum_{i=1}^k \lambda_i y_i \mathbf{x}_i \quad (8)$$

According to the Karush-Kuhn-Tucker (KKT) conditions, only the support vectors (SV) lead to $\lambda_i \neq 0$. This means that only the SVs appear in the optimal result.

2.2 FIRST ORDER RELIABILITY METHOD (FORM)

FORM is a physics-based reliability method, which linearizes the limit-state function $g(\mathbf{X})$ at the Most Probable Point (MPP) using the first order Taylor expansion. Three steps are involved.

Firstly, assume that all the random variables in \mathbf{X} (in the X-space) are independent. The original random variables $\mathbf{X} = (X_1, X_2, \dots, X_n)$ are transformed into standard normal random variables $\mathbf{U} = (U_1, U_2, \dots, U_n)$ in the U-space. The transformation is given by [15]

$$x_i = F_i^{-1}(\Phi(u_i)) = T(u_i) \quad (i = 1, 2, \dots, n) \quad (9)$$

where $F_i(\cdot)$ and $\Phi(\cdot)$ are the cumulative distribution functions (CDF) of X_i and a standard normal variable, respectively, and $T(\cdot)$ denotes the transformation function.

Secondly, at the MPP, $g(T(\mathbf{U}))$ can be approximated to a linear function as follows:

$$G(\mathbf{U}) = \beta + \boldsymbol{\alpha}\mathbf{U}^T \quad (10)$$

Thirdly, with the new limit-state function $G(\mathbf{U})$ obtained in Eq. (10), p_f is calculated by

$$p_f = \Pr\{G(\mathbf{U}) < 0\} = \Phi(-\beta) \quad (11)$$

3. SYSTEM RELIABILITY PREDICTION WITH COMBINED PHYSICS- AND STATISTICS-BASED METHODS

The objective of this study is to integrate statistics- and physics-based reliability methods so that the joint probability density function (PDF) of all the component states is available. As discussed previously, the two different types of components (failure modes) are defined as follows:

- Type I: Type I components have limit-state functions and their reliabilities can be estimated by physics-based reliability methods, such as FORM.
- Type II: Type II components do not have limit-state functions, and their reliabilities are estimated by statistics-based methods. Limited reliability data collected at both working and failure states are provided.

The main idea of this work is to construct limit-state functions for type II components using testing data. Then with all the available limit-state functions, the system reliability could be estimated.

3.1 CONSTRUCT A LIMIT-STATE FUNCTION FOR A TYPE II COMPONENT

Assume that samples of a type II component are tested at a number of training points \mathbf{x}_i , $i = 1, 2, \dots, m$. If the component is working at \mathbf{x}_i , the state is $y_i = +1$. If the component fails at \mathbf{x}_i , the state is $y_i = -1$. Then we have a dataset (\mathbf{x}_i, y_i) , $i = 1, 2, \dots, m$. Through the X-to-U transformation we have a new dataset (\mathbf{u}_i, y_i) , $i = 1, 2, \dots, m$, where

$$u_{ij} = \Phi^{-1}(F_j(x_{ij})) \quad (12)$$

in which subscript j indicates the j -th component of the i -th sample point.

With sufficient number of experiments, the probability of failure of the component p_f can also be estimated with a statistics-based reliability method. We hence assume that the component reliability is available.

In this study, we use SVM to construct the limit-state function in the form of $G^{\text{II}}(\mathbf{U}) = \beta + \boldsymbol{\alpha}\mathbf{U}^T$, in which β is known and is given by $\beta = -\Phi^{-1}(p_f)$. Now the task becomes to find a unit vector $\boldsymbol{\alpha}$ that defines the hyperplane $G^{\text{II}}(\mathbf{U})$. This can be done with the following two steps.

Step 1: Assume the hyperplane for dataset (\mathbf{u}_i, y_i) obtained from SVM method is given by

$$H(\mathbf{U}) = \beta + \boldsymbol{\omega}\mathbf{U}^T \quad (13)$$

in which

$$\boldsymbol{\omega} = \sum_{i=1}^k \lambda_i y_i \mathbf{u}_i \quad (14)$$

where λ_i is given by

$$\begin{cases} \max_{\lambda} L = \sum_{i=1}^k \lambda_i - \frac{1}{2} \sum_{i,j=1}^k \lambda_i \lambda_j y_i y_j \mathbf{u}_i \mathbf{u}_j^T \\ \text{s.t. } \sum_{i=1}^k y_i \lambda_i = 0, \lambda_i \geq 0. \end{cases} \quad (15)$$

Step 2: Replace $\boldsymbol{\alpha}$ by $\frac{\boldsymbol{\omega}}{\|\boldsymbol{\omega}\|}$, then the linear function of hyperplane $G^{\text{II}}(\mathbf{U})$ is

rewritten as

$$G^{\text{II}}(\mathbf{U}) = \beta + \frac{\boldsymbol{\omega}}{\|\boldsymbol{\omega}\|} \mathbf{U}^T \quad (16)$$

3.2 SYSTEM RELIABILITY ANALYSIS

We now discuss the system reliability analysis using the proposed integrated statistics- and physics-based reliability method. Assume there are m components (failure modes) and $m \geq 2$. The limit-state functions $g_i^{\text{I}}(\cdot)$, ($i=1,2,\dots,m_1$) of m_1 type I components are available. For the other m_2 ($m_2 = m - m_1$) type II components, their observations or training points (\mathbf{x}, y) are available.

For a type I component, the limit-state functions in the U-space can be written as

$$g_i^{\text{I}}(\mathbf{X}) \xrightarrow{\text{FORM}} G_i^{\text{I}}(\mathbf{U}) = \beta_i^{\text{I}} + \boldsymbol{\alpha}_i^{\text{I}} \mathbf{U}^T \quad (i=1,2,\dots,m_1) \quad (17)$$

For type II components, the limit-state functions constructed by SVM is

$$g_j^{\text{II}}(\mathbf{X}) \xrightarrow{\text{SVM}} G_j^{\text{II}}(\mathbf{U}) = \beta_j^{\text{II}} + \frac{\boldsymbol{\omega}_j}{\|\boldsymbol{\omega}_j\|} \mathbf{U}^T = \beta_j^{\text{II}} + \boldsymbol{\alpha}_j^{\text{II}} \mathbf{U}^T \quad (j = m_1 + 1, m_1 + 2, \dots, m) \quad (18)$$

The system reliability is then given by

$$R_s = \Pr \left(\bigcap_{i=1}^{m_1} -G_i^I(\mathbf{U}) < 0 \cap \bigcap_{j=m_1+1}^m -G_j^{II}(\mathbf{U}) < 0 \right) = \int_{\Omega} \phi_G(\mathbf{v}) d\mathbf{v} \quad (19)$$

where $\phi_G(\cdot)$ is the joint PDF of the states of the m components, and Ω is the system safe region defined by

$$\Omega = \left\{ \mathbf{U} \mid -G_i^I(\mathbf{U}) < 0, -G_j^{II}(\mathbf{U}) < 0 \ (i=1,2,\dots,m_1; j=m_1+1,m_1+2,\dots,m) \right\} \quad (20)$$

Thus, $\phi_G(\cdot)$ is actually the joint PDF of a multivariate normal distribution determined by the mean vector $\boldsymbol{\mu}$ and covariance matrix $\boldsymbol{\Sigma}$. The mean vector $\boldsymbol{\mu}$ is given by

$$\boldsymbol{\mu} = (-\beta_1^I - \beta_2^I, \dots, -\beta_{m_1}^I, -\beta_{m_1+1}^{II}, -\beta_{m_1+2}^{II}, \dots, -\beta_m^{II}) \quad (21)$$

in which β_i^I ($i=1,2,\dots,m_1$) is obtained by FORM, and β_j^{II} ($j=m_1+1,m_1+2,\dots,m$) is computed by $\beta_j^{II} = -\Phi^{-1}(p_{f_j})$. And $\boldsymbol{\Sigma}$ is given by

$$\boldsymbol{\Sigma} = \begin{bmatrix} 1 & \rho_{12} & \cdots & \rho_{1m} \\ \rho_{21} & 1 & & \rho_{2m} \\ \vdots & \vdots & \ddots & \vdots \\ \rho_{m1} & \rho_{m2} & \cdots & 1 \end{bmatrix}_{m \times m} \quad (22)$$

in which ρ_{ij} is the correlation coefficient between the i -th and j -th components and is calculated by

$$\rho_{ij} = \rho_{ji} = \begin{cases} \boldsymbol{\alpha}_i^I (\boldsymbol{\alpha}_j^I)^T, & i < j \leq m_1 \\ \boldsymbol{\alpha}_i^I (\boldsymbol{\alpha}_j^{II})^T, & i \leq m_1 < j \\ \boldsymbol{\alpha}_i^{II} (\boldsymbol{\alpha}_j^{II})^T, & m_1 < i < j \end{cases} \quad (23)$$

According to Eq. (18), we have $\alpha_j^{\text{II}} = \omega_j / \|\omega_j\|$ ($j = m_1 + 1, m_1 + 2, \dots, m$). To verify the direction of α_j^{II} , we first substitute $\alpha_j^{\text{II}} = \omega_j / \|\omega_j\|$ into Eq. (18). Since $g(\mathbf{X}) < 0$ or $G(\mathbf{U} < 0)$ means a failed state, Eq. (18) should be negative at any sample point with given label $y = -1$. Otherwise, we change the direction of α_j^{II} by reversing the signs of all the components in it. The details of doing this are shown in Example 1 in Section 4.

Now we obtain the mean vector $\boldsymbol{\mu}$ and covariance matrix $\boldsymbol{\Sigma}$, and the expression of $\phi_G(\mathbf{v})$ is given by [16]

$$\phi_G(\mathbf{v}) = \frac{1}{\sqrt{(2\pi)^n |\boldsymbol{\Sigma}|}} \exp\left(-\frac{1}{2}(\mathbf{v} - \boldsymbol{\mu})^T \boldsymbol{\Sigma}^{-1}(\mathbf{v} - \boldsymbol{\mu})\right) \quad (24)$$

Then R_s can be easily evaluated by integrating $\phi_G(\mathbf{v})$ in the safe region Ω , and the probability of system failure is $p_{f_s} = 1 - R_s$.

The proposed method provides a new way to approximate linear limit-state functions for components with only estimated probabilities of failure and limited reliability data. The dependency between components is automatically accommodated in the system covariance matrix. Also, it is computationally efficient due to the linear form of all the limit-state functions.

FORM is used in this feasibility study, but it is not a necessity of the proposed method. Other reliability methods, such as SORM and SVM-based methods, can also be used. One can choose a method if it satisfies the following two requirements: the method can produce the probability of failure p_f so that the reliability index is obtained by

$\beta = -\Phi^{-1}(p_f)$, and a directional vector α is available or can be derived. Both SORM and SVM-based methods satisfy the above requirements.

4. EXAMPLES

In this section, three examples are presented. To validate the proposed method, we at first assume that the true limit-state functions of type II components exist, but unknown to system designers. Using these true limit-state functions, we can obtain the true system reliability from a physics-based reliability method. To mimic the actual physical testing for type II components, we perform computer-based testing (random sampling) by calling the true limit-state functions and then apply the proposed method.

4.1 EXAMPLE 1 – A MATHEMATICAL PROBLEM

A system consists of two physical components, and each has one failure mode. There are two basic random variables denoted by $\mathbf{X} = (X_1, X_2)$, where $X_1 \sim N(10, 0.8^2)$, and $X_2 \sim N(30, 1.5^2)$. The limit-state function of the first component (Type I) is given by

$$g_1^I(\mathbf{X}) = -152 + 8.6X_1 + 3.4X_2 \quad (25)$$

The limit-state function of the second component is unknown, and the component probability of failure $p_{f_2} = 2.5625 \times 10^{-6}$ is estimated by a statistics-based approach. Thus, this component is a type II component, and a number of experiments are performed to estimate its reliability. We assume the true limit-state function is given by

$$g_2^{II(\text{true})}(\mathbf{X}) = -198 + 5.4X_1 + 6.4X_2 \quad (26)$$

The corresponding true limit-state function in the U-space is

$$G_2^{\text{II}(\text{true})}(\mathbf{U}) = 4.5596 + 0.4104U_1 + 0.9119U_2 \quad (27)$$

26 samples of \mathbf{X} are generated and the corresponding values of y are computed using Eq. (26). The simulated results are given in Table 1. Training points are given in both X- and U-spaces, and p_{f2} is also obtained based on Eq. (26).

Table 1 Training points

	\mathbf{x}		\mathbf{u}		y
1	7.6054	24.3070	-2.9932	-3.7953	-1
2	9.4886	22.5981	-0.6392	-4.9346	-1
3	10.0151	31.5254	0.0189	1.0169	+1
⋮	⋮	⋮	⋮	⋮	⋮
25	8.7630	23.4822	-1.5462	-4.3452	-1
26	8.2552	22.9919	-2.1810	-4.6721	-1

For the first component, FORM is used directly. The new limit-state function is given by

$$G_1^{\text{I}}(\mathbf{U}) = \beta_1^{\text{I}} + \boldsymbol{\alpha}_1^{\text{I}}\mathbf{U}^T = 4.2036 + 0.8034U_1 + 0.5955U_2 \quad (28)$$

For the second component, $\beta_2^{\text{II}} = -\Phi^{-1}(p_{f2}) = 4.5596$. Using the SVM method, an optimal hyperplane is obtained as shown in Figure 2. The weight vector $\boldsymbol{\omega} = (0.2689, 0.5695)$ is acquired. Then the unit vector $\boldsymbol{\alpha}_2^{\text{II}}$ is calculated by

$\boldsymbol{\alpha}_2^{\text{II}} = \frac{\boldsymbol{\omega}_2}{\|\boldsymbol{\omega}_2\|} = (0.4270, 0.9042)$, and the corresponding limit-state function is given by

$$G_2^{\text{II}}(\mathbf{U}) = \beta_2^{\text{II}} + \boldsymbol{\alpha}_2^{\text{II}}\mathbf{U}^T = 4.5596 + 0.4270U_1 + 0.9042U_2 \quad (29)$$

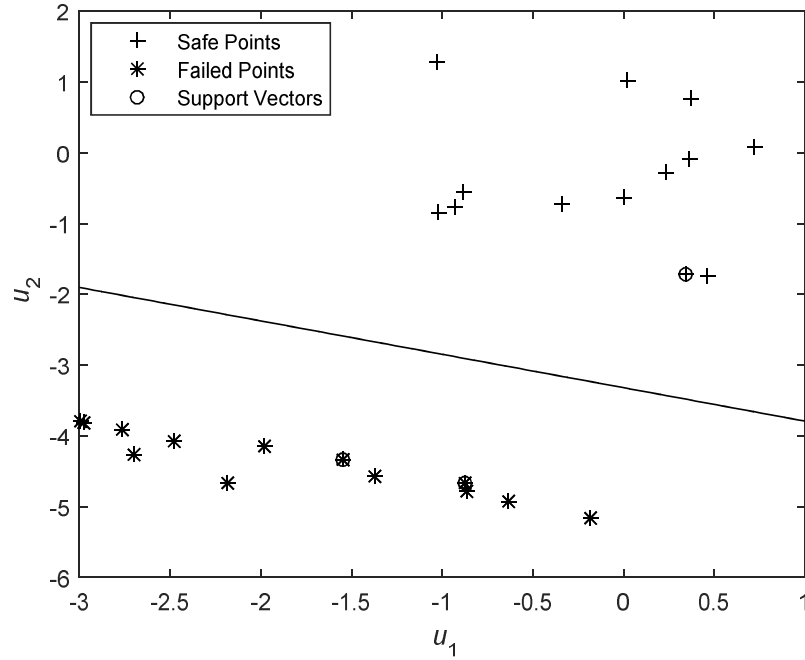

Figure 2 Training points classification using SVM

To verify the direction of α_2^{II} , we first arbitrarily pick one training point, for instance, $\mathbf{u}_1 = (-2.9932, -3.7953)$, where a failure ($y = -1$) occurs. Then we plug \mathbf{u}_1 into Eq. (29) and obtain $G_2^{\text{II}}(\mathbf{U}) = -0.11 < 0$, which indicates a failure. Thus, the failed state is consistent with the label of \mathbf{u}_1 , that is $y_1 = -1$, which means α_2^{II} has a correct direction.

With the obtained limit-state functions in Eqs. (28) and (29), we can easily estimate the system reliability by

$$R_s = \Pr(-G_1^{\text{I}}(\mathbf{U}) < 0 \cap -G_2^{\text{II}}(\mathbf{U}) < 0) = \int_{\Omega} \phi_{\mathbf{G}}(\mathbf{v}) d\mathbf{v} \quad (30)$$

The mean vector $\boldsymbol{\mu}$ of $\phi_{\mathbf{G}}(\mathbf{v})$ is given by

$$\boldsymbol{\mu} = (-\beta_1^{\text{I}}, -\beta_2^{\text{II}}) = (-4.2036, -4.5596) \quad (31)$$

And the covariance matrix Σ of $\phi_G(\mathbf{v})$ is computed by

$$\Sigma = \begin{bmatrix} 1 & \rho_{12} \\ \rho_{21} & 1 \end{bmatrix} = \begin{bmatrix} 1 & \alpha_1^I (\alpha_2^{II})^T \\ \alpha_1^I (\alpha_2^{II})^T & 1 \end{bmatrix} = \begin{bmatrix} 1 & 0.8815 \\ 0.8815 & 1 \end{bmatrix} \quad (32)$$

Substituting Eqs. (31) and (32) into Eq. (30), we obtain

$$p_{fs} = 1 - R_s = 1.4441 \times 10^{-5}.$$

To validate the result, we use $g_1^I(\mathbf{X})$ and $g_2^{II(\text{true})}(\mathbf{X})$ to calculate the system reliability based on FORM. The result is 1.4523×10^{-5} and is regarded as the true probability of system failure. For comparison, we also compute the system reliability using the independence assumption method. All the results are listed in Table 2. The independence assumption method produces an error of 8.1%. The large error comes from neglecting the strong correlation indicated by $\rho_{12} = 0.8815$. The proposed method has an error of only 0.56%, which shows much higher accuracy.

Table 2 Results of system reliability from different methods

	Proposed Method	Independence Assumption Method	True Value
p_{fs}	1.4441×10^{-5}	1.5699×10^{-5}	1.4523×10^{-5}
Error (%)	0.56	8.1	—

4.2 EXAMPLE 2– A CANTILEVER BEAM PROBLEM WITH MULTIPLE FAILURE MODES

As shown in Figure 3, a cantilever beam is subjected to moments M_1 and M_2 ; forces Q_1 and Q_2 ; and distributed loads denoted by (q_{L1}, q_{R1}) and (q_{L2}, q_{R2}) . Among

these external loads, M_1 , M_2 , and Q_1 are random variables. The other random variables are the dimensions of a_1 , a_2 , and b_1 ; the yield strength S_a ; and the allowable shear stress τ_a . Thus, there are totally eight basic random variables, as listed in Table 3, in which N means Normal Distribution and $LogN$ means Lognormal Distribution. For each distribution, the first parameter is the mean value and the second one is the standard deviation. The deterministic parameters are listed in Table 4.

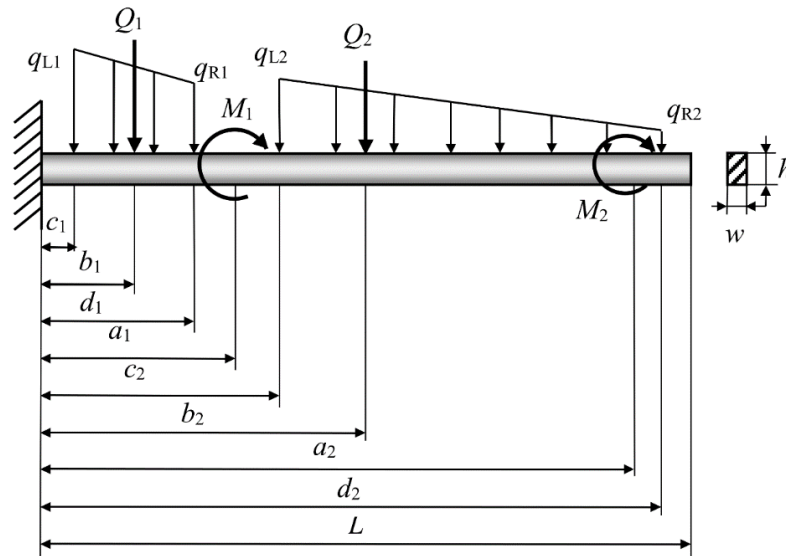

Figure 3 A cantilever beam system

The cantilever beam has three failure modes. Thus this problem involves a system reliability analysis, and each failure mode is considered as a component. The first failure mode is due to excessive normal stress, and its limit-state function is known and given by

$$g_1^I(\mathbf{X}) = S_a - \frac{6M}{wh^2} \quad (33)$$

in which M is the bending moment at the root and is calculated by

$$M = \sum_{i=1}^2 M_i + \sum_{i=1}^2 Q_i b_i + \sum_{i=1}^2 q_{Li} (d_i - c_i)(d_i + c_i) / 2 + \sum_{i=1}^2 [(q_{Ri} - q_{Li})(d_i - c_i) / 2][c_i + 2(d_i - c_i) / 3] \quad (34)$$

Thus this failure mode is treated as a type I component.

Table 3 Basic random variables

Random Variables		Distribution
X_1	M_1 (Nm)	$N(50 \times 10^3, 2 \times 10^3)$
X_2	M_2 (Nm)	$N(30 \times 10^3, 2 \times 10^3)$
X_3	a_1 (m)	$N(1.5, 0.005)$
X_4	a_2 (m)	$N(4.5, 0.005)$
X_5	Q_1 (N)	$LogN(65 \times 10^3, 13 \times 10^3)$
X_6	b_1 (m)	$N(0.7, 0.005)$
X_7	S_a (Pa)	$N(62.5 \times 10^6, 10^6)$
X_8	τ_a (Pa)	$N(3.6 \times 10^6, 10^5)$

The second failure mode is caused by the excessive shear stress with a known limit-state function given by

$$g_2^1(\mathbf{X}) = \tau_a - \tau_{\max} \quad (35)$$

in which τ_a is the allowable shear stress, and τ_{\max} is the maximal shear stress computed

by

$$\tau_{\max} = \frac{3}{2wh} \left(\sum_{i=1}^2 Q_i + \sum_{i=1}^2 q_{Li} (d_i - c_i) + \sum_{i=1}^2 \frac{(q_{Ri} - q_{Li})(d_i - c_i)}{2} \right) \quad (36)$$

Thus this failure mode is also treated as a type I component.

Table 4 Deterministic parameters

	Parameters	Values
1	$Q_2(\text{N})$	30×10^3
2	$b_2(\text{m})$	2.5
3	$q_{L1}(\text{N/m})$	30×10^3
4	$q_{L2}(\text{N/m})$	20×10^3
5	$c_1(\text{m})$	0.25
6	$c_2(\text{m})$	1.75
7	$q_{R1}(\text{N/m})$	20×10^3
8	$q_{R2}(\text{N/m})$	10^3
9	$d_1(\text{m})$	1.25
10	$d_2(\text{m})$	4.75
11	$L(\text{m})$	5.1
12	$w(\text{m})$	0.204
13	$h(\text{m})$	0.403

The third failure mode is caused by excessive deflection, and its limit-state function is not available. It is therefore treated as a type II component. Then reliability testing is performed to estimate the probability of failure and the result is p_{f3} . To simulate physical experiments, we generate training points by simulation. We assume that the true limit-state function for FM3 is given by

$$g_3^{\text{II}(\text{true})}(\mathbf{X}) = v_a - v_{\max} \quad (37)$$

in which $v_a = 8.4 \text{ mm}$ is the allowable deflection, and v_{\max} is the maximal tip deflection given by

$$\begin{aligned}
v_{\max} = & \frac{1}{EI} \left[\frac{ML^2}{2} + \frac{BL^3}{2} + \sum_{i=1}^2 \frac{M_i(L-a_i)^2}{2} - \sum_{i=1}^2 \frac{Q_i(L-b_i)^3}{6} \right] \\
& + \frac{1}{EI} \left[-\sum_{i=1}^2 \frac{q_{Li}(L-c_i)^4}{24} - \sum_{i=1}^2 \frac{(q_{Ri}-q_{Li})(L-c_i)^5}{120(d_i-c_i)} + \sum_{i=1}^2 \frac{q_{Ri}(L-d_i)^4}{24} \right] \\
& + \frac{1}{EI} \sum_{i=1}^2 \frac{(q_{Ri}-q_{Li})(L-d_i)^5}{120(d_i-c_i)}
\end{aligned} \quad (38)$$

in which B is the reaction force at the fixed end. The Young's modulus is $E = 200 \times 10^9$ Pa and the moment of inertia is $I = \frac{wh^3}{12}$. We then generate 24 samples of \mathbf{X} and obtain samples of y using Eq. (37). Also, $p_{f3} = 4.1309 \times 10^{-4}$ is given, which is obtained based on Eq. (37).

Using the proposed SVM method, eight support vectors are obtained, and the weight vector is $\boldsymbol{\omega}_3 = (0.137, 0.560, -0.065, -0.037, 0.483, -0.059, -0.013, 0.012)$. Then the approximated limit-state function for FM3 is given by

$$G_3^{\text{II}}(\mathbf{U}) = \beta_3^{\text{II}} + \boldsymbol{\alpha}_3^{\text{II}} \mathbf{U}^T \quad (39)$$

in which $\beta_3^{\text{II}} = -\Phi^{-1}(p_{f3}) = 3.3439$ and $\boldsymbol{\alpha}_3^{\text{II}}$ is the unit vector calculated by

$$\boldsymbol{\alpha}_3^{\text{II}} = \frac{\boldsymbol{\omega}_3}{\|\boldsymbol{\omega}_3\|} = (0.181, 0.738, -0.085, -0.049, 0.637, -0.077, -0.017, 0.016).$$

The first two failure modes are type I components, and FORM produces the following results:

$$G_i^{\text{I}}(\mathbf{U}) = \beta_i^{\text{I}} + \boldsymbol{\alpha}_i^{\text{I}} \mathbf{U}^T \quad (i=1,2) \quad (40)$$

in which

$$\begin{aligned}
\beta_1^{\text{I}} = 2.9806, \quad \boldsymbol{\alpha}_1^{\text{I}} = (-0.121, -0.121, 0, 0, -0.926, -0.033, 0.335, 0) \\
\beta_2^{\text{I}} = 2.7065, \quad \boldsymbol{\alpha}_2^{\text{I}} = (0, 0, 0, 0, -0.968, 0, 0, 0.250)
\end{aligned} \quad (41)$$

Thus, $G_i^I(\mathbf{U})$ ($i=1,2$) and $G_3^{II}(\mathbf{U})$ follow a multivariate normal distribution with $\boldsymbol{\mu}$ and $\boldsymbol{\Sigma}$ given by

$$\boldsymbol{\mu} = (-2.9806, -2.7065, -3.3439) \quad (42)$$

$$\boldsymbol{\Sigma} = \begin{bmatrix} 1 & \rho_{12} & \rho_{13} \\ \rho_{12} & 1 & \rho_{23} \\ \rho_{13} & \rho_{23} & 1 \end{bmatrix} = \begin{bmatrix} 1 & 0.897 & 0.705 \\ 0.897 & 1 & 0.613 \\ 0.705 & 0.613 & 1 \end{bmatrix} \quad (43)$$

where ρ_{12} , ρ_{13} and ρ_{23} are the correlation coefficients between $G_1^I(\mathbf{U})$ and $G_2^I(\mathbf{U})$; $G_1^I(\mathbf{U})$ and $G_3^{II}(\mathbf{U})$; and $G_2^I(\mathbf{U})$ and $G_3^{II}(\mathbf{U})$, respectively. Then, the system reliability is evaluated and is given by $p_{fs} = 4.1528 \times 10^{-3}$.

With all the given limit-state functions $g_1^I(\mathbf{X})$, $g_2^I(\mathbf{X})$, and $g_3^{II(\text{true})}(\mathbf{X})$, the true system reliability could be obtained using FORM and is assumed as a benchmark for comparison. Likewise, we also estimate the probability of system failure using the independence assumption method. The results are shown in Table 5, which indicates that the proposed method is more accurate than the independence assumption method.

Table 5 Results of system reliability

	Proposed Method	Independence Assumption Method	True Value
p_{fs}	4.1528×10^{-3}	5.2442×10^{-3}	4.1582×10^{-3}
Error (%)	0.13	26.12	—

4.3 EXAMPLE 3 – A SYSTEM WITH MULTIPLE COMPONENTS

Figure 4 shows a crank-slider system consists of four physical components. An external moment is applied to joint A . We only focus on the time instant when $\theta_2 = \pi / 2$.

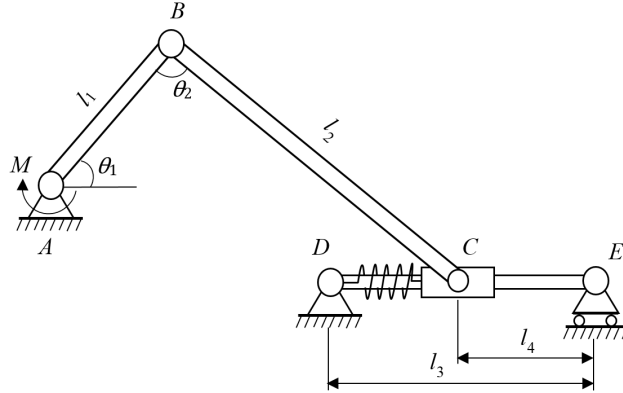

Figure 4 A crank-slider system

Physical component 1 is beam AB with a length of l_1 , and the cross section is defined by the width b_1 and height h_1 . Beam AB has one failure mode (FM1) due to excessive normal stress, and the limit-state function is known and is given by

$$g_1^1(\mathbf{X}) = S_{a1} - S_1 \quad (44)$$

where S_{a1} is the allowable normal stress, and $S_1 = \frac{M(h_1/2)}{b_1 h_1^3 / 12}$ is the maximal normal stress.

Physical component 2 is beam BC with a length of l_2 , the cross section is defined by the width b_2 and height h_2 . The single failure mode (FM2) for beam BC is caused by buckling with a known limit-state function given by

$$g_2^1(\mathbf{X}) = P_{cr} - F_{BC} \quad (45)$$

in which $P_{cr} = \frac{\pi^2 E_2 I_2}{(Kl_2)^2}$ is the critical force for buckling, $I_2 = \frac{b_2 h_2^3}{12}$, and $F_{BC} = M / l_1$ is the force developed in the beam.

Physical component 3 is the shaft DE with a length of l_3 and a diameter of d_4 . The shaft has two failure modes (FM3 and FM4) caused by excessive deflection and excessive normal stress, respectively. The corresponding limit-state functions are known and given by

$$\begin{cases} g_3^I(\mathbf{X}) = \delta_{a3} - \delta_3 \\ g_4^I(\mathbf{X}) = S_{a4} - S_4 \end{cases} \quad (46)$$

in which δ_{a3} is the allowable deflection, and δ_3 is the maximal deflection given by

$$\delta_3 = \frac{F_{BC} \sin(\pi/2 - \theta_1) l_4 (l_3^2 - l_4^2)^{3/2}}{9\sqrt{3} l_4 E_4 (\pi/4) (d_4/2)^4} \quad (47)$$

where E_4 is the Young's modulus of shaft DE . S_{a4} is the allowable normal stress, and S_4 is the maximal normal stress developed in the shaft and is calculated by

$$S_4 = \frac{M_{\max} c}{I_4} = \frac{F_{BC} \sin(\pi/2 - \theta_1) (d_4/2)}{(\pi/4) (d_4/2)^4} \quad (48)$$

Physical component 4 is the spring CD with one failure mode (FM5) due to excessive shear stress applied to the spring coils. The limit-state function is unknown while the probability of failure is given by $p_{f3} = 1.04 \times 10^{-3}$. Likewise, to simulate the testing, we assume the true limit-state function as

$$g_5^{\text{II (true)}}(\mathbf{X}) = \tau_{a5} - \tau_5 \quad (49)$$

in which $\tau_{a5} \sim N(100 \times 10^6, (25 \times 10^6)^2)$ Pa is the allowable shear stress of the spring coil, and τ_5 is the developed maximal shear stress and calculated by

$$\tau_5 = \frac{F_{BC} \cos(\pi/2 - \theta_1) D}{\pi d^3} \left(\frac{4D - d}{4D - 4d} + \frac{0.615d}{D} \right) \quad (50)$$

in which $D \sim N(34.7 \times 10^{-3}, 10^{-4})$ m is the outer diameter of the spring, and $d = 29.5 \times 10^{-3}$ m is the spring inner diameter. We then generate 30 training points of \mathbf{X} and obtain samples of y based on Eq. (49) and the distributions of M_1 , l_1 , D , and τ_{a5} .

All the random variables known by the system designers are listed in Table 6 and the known deterministic parameters are listed in Table 7. Since D and τ_{a5} are only known by the spring supplier, they are not listed in Table 6. They are denoted as X_9 and X_{10} . Thus, there are actually 10 basic random variables in the system. For FM5, the training points are provided in the form of (X_1, X_2, X_9, X_{10}) .

Table 6 Random variables

	Random Variables	Distribution
X_1	M_1 (Nm)	$N(350, 65)$
X_2	l_1 (m)	$N(0.3, 10^{-4})$
X_3	l_2 (m)	$N(0.9, 10^{-3})$
X_4	b_1 (m)	$N(0.022, 5 \times 10^{-4})$
X_5	h_1 (m)	$N(0.019, 5 \times 10^{-4})$
X_6	b_2 (m)	$N(0.015, 5 \times 10^{-4})$
X_7	h_2 (m)	$N(0.009, 5 \times 10^{-4})$
X_8	d_4 (m)	$N(0.0228, 10^{-4})$

Table 7 Deterministic parameters

No.	Deterministic Parameters	Values
1	E_2 (Pa)	200×10^9
2	E_4 (Pa)	200×10^9
3	K	1
4	l_3 (m)	0.96
5	l_4 (m)	0.31
6	S_{a1} (Pa)	400×10^6
7	S_{a4} (Pa)	460×10^6
8	δ_{a3} (m)	0.0032

As discussed in Section 4, the five FMs in the system are treated as five components at the system level. The first four FMs with known limit-state functions $g_i^I(\mathbf{X})$ ($i = 1, 2, 3, 4$) belong to type I components, and FM5 is a type II component since its limit-state function $g_5^{II}(\mathbf{X})$ is not available.

For type-I components, $g_i^I(\mathbf{X})$ could be approximated by FORM as

$$G_i^I(\mathbf{U}) = \beta_i^I + \boldsymbol{\alpha}_i^I \mathbf{U}^T \quad (i = 1, 2, \dots, 4) \quad (51)$$

in which

$$\begin{aligned} \beta_1^I &= 2.5099, & \boldsymbol{\alpha}_1^I &= (-0.91, 0, 0, 0.16, 0.38, 0, 0, 0, 0, 0) \\ \beta_2^I &= 2.6609, & \boldsymbol{\alpha}_2^I &= (-0.60, 1.4 \times 10^{-3}, -0.02, 0, 0, 0.14, 0.79, 0, 0, 0) \\ \beta_3^I &= 2.5653, & \boldsymbol{\alpha}_3^I &= (-0.99, 2.6 \times 10^{-4}, 1.6 \times 10^{-2}, 0, 0, 0, 0, 0, 0.14, 0) \\ \beta_4^I &= 2.4145, & \boldsymbol{\alpha}_4^I &= (-0.99, 2.6 \times 10^{-4}, 1.5 \times 10^{-2}, 0, 0, 0, 0, 0, 0.10, 0) \end{aligned} \quad (52)$$

For the type II component, using the proposed SVM method, the limit-state function is reconstructed as

$$G_5^{II}(\mathbf{U}) = \beta_5^{II} + \boldsymbol{\alpha}_5^{II} \mathbf{U}^T \quad (53)$$

in which $\beta_5^{\text{II}} = -\Phi^{-1}(p_{f_s}) = 3.0785$ and $\alpha_5^{\text{II}} = (0.911, -0.144, 0, 0, 0, 0, 0, 0, 0.320, -0.217)$.

Then $G_i^{\text{I}}(\mathbf{U})$ ($i=1,2,\dots,4$) and $G_5^{\text{II}}(\mathbf{U})$ follow a multivariate normal distribution with the mean vector and covariance matrix given by

$$\boldsymbol{\mu} = (-2.5099, -2.6099, -2.5653, -2.4145, -3.0785) \quad (54)$$

$$\boldsymbol{\Sigma} = \begin{bmatrix} 1 & 0.546 & 0.903 & 0.907 & 0.831 \\ 0.546 & 1 & 0.593 & 0.595 & 0.546 \\ 0.903 & 0.593 & 1 & 0.999 & 0.902 \\ 0.907 & 0.595 & 0.999 & 1 & 0.906 \\ 0.831 & 0.546 & 0.902 & 0.906 & 1 \end{bmatrix} \quad (55)$$

Using Eq. (24), the estimated probability of system failure is $p_{f_s} = 1 - R_s = 0.0133$.

With $g_i^{\text{I}}(\mathbf{X})$ ($i=1,2,3,4$) and $g_5^{\text{II}(\text{true})}(\mathbf{X})$ exactly known, the true system reliability could be directly acquired using FORM. The results in Table 8 show that the proposed method are more accurate than the independence assumption method.

Table 8 Results of system reliability

	Proposed Method	Independence Assumption Method	True Value
p_{f_s}	0.0133	0.0238	0.0142
Error (%)	6.49	67.74	—

5. CONCLUSIONS

This work verifies the feasibility of integrating statistics- and physics-based method for system reliability analysis. It is common that component reliability is

estimated by a statistic-based method; with the increasing use of physics-based computational models, it is also possible that component reliability is estimated by a physics-based method. This study deals with the difficulty of obtaining the joint probability density when physics-based methods are used for some components (type I) and statistics-based methods are used for other components (type II).

The physics-based method employed in this study is the First Order Reliability Method (FORM), which is directly used for type I components whose physics-based limit-state functions are available. For type II components whose physics-based limit-state functions are unknown, with a statistics-based method, reliability experiments are performed. Then their reliabilities are estimated. A supervised learning strategy through Support Vector Machines (SVM) is developed to create limit-state functions for type II components. The proposed method makes the limit-state functions of all the components available thereby leading to a multivariate normal probability density function, whose integration in the safe region then produces the system reliability.

This feasibility study makes a number of assumptions, such as the distributions of basic random variables for both types of components are known, the component reliability is calculated by FORM, the safety-failure boundary is linear with respect to basic variables in the standard normal space, and sample points from reliability testing in both safe and failure regions are available. If the data set has a nonlinear pattern, the proposed method can still accommodate such nonlinearity by introducing slack variables to the SVM model so that the linear assumption could be violated slightly. If the nonlinearity is high, SVM methodologies that produce nonlinear models should be employed.

ACKNOWLEDGEMENTS

This material is based upon work supported by the National Science Foundation under Grant No. CMMI 1562593.

REFERENCES

- [1] Cheng, Y., Conrad, D. C., and Du, X., 2017, "Narrower System Reliability Bounds With Incomplete Component Information and Stochastic Process Loading," *Journal of Computing and Information Science in Engineering*, 17(4), p. 041007.
- [2] Lawless, J., 1983, "Statistical methods in reliability," *Technometrics*, 25(4), pp. 305-316.
- [3] Mahadevan, S., 1997, "Physics-based reliability models," *Mechanical Engineering-New York and Basel-Marcel Dekker*, pp. 197-232.
- [4] Chiralaksanakul, A., and Mahadevan, S., 2005, "First-order approximation methods in reliability-based design optimization," *Journal of Mechanical Design*, 127(5), pp. 851-857.
- [5] Zhao, Y. G., and Ono, T., 1999, "A general procedure for first/second-order reliability method (FORM/SORM)," *Structural Safety*, 21(2), pp. 95-112.
- [6] Du, X., and Sudjianto, A., 2004, "First order saddlepoint approximation for reliability analysis," *AIAA journal*, 42(6), pp. 1199-1207.
- [7] Choi, S.-K., Grandhi, R., and Canfield, R. A., 2006, *Reliability-based structural design*, Springer Science & Business Media.
- [8] Song, J., and Kang, W.-H., 2009, "System reliability and sensitivity under statistical dependence by matrix-based system reliability method," *Structural Safety*, 31(2), pp. 148-156.
- [9] Fiondella, L., and Xing, L., "Reliability of two failure mode systems subject to correlated failures," *Proc. Proceedings - Annual Reliability and Maintainability Symposium*.
- [10] Hu, Z., and Du, X., 2017, "System reliability prediction with shared load and unknown component design details," *AI EDAM*, 31(3), pp. 223-234.

- [11] Hu, Z., and Du, X., "A physics-based reliability method for components adopted in new series systems," Proc. 2016 Annual Reliability and Maintainability Symposium (RAMS), IEEE, pp. 1-7.
- [12] Hu, Z., and Du, X., 2017, "System reliability analysis with in-house and outsourced components," 2017 2nd international Conference on System Reliability and Safety, IEEE, Milan, Italy.
- [13] Basudhar, A., Missoum, S., and Sanchez, A. H., 2008, "Limit state function identification using support vector machines for discontinuous responses and disjoint failure domains," Probabilistic Engineering Mechanics, 23(1), pp. 1-11.
- [14] Basudhar, A., Dribusch, C., Lacaze, S., and Missoum, S., 2012, "Constrained efficient global optimization with support vector machines," Structural and Multidisciplinary Optimization, 46(2), pp. 201-221.
- [15] Rosenblatt, M., 1952, "Remarks on a multivariate transformation," The annals of mathematical statistics, 23(3), pp. 470-472.
- [16] Hogg, R. V., and Craig, A. T., 1995, Introduction to mathematical statistics.(5th edition), Upper Saddle River, New Jersey: Prentice Hall.

III. ONE-CLASS SUPPORT VECTOR MACHINES WITH A BIAS CONSTRAINT AND ITS APPLICATION IN SYSTEM RELIABILITY PREDICTION

Zhengwei Hu, Zhangli Hu, and Xiaoping Du

Department of Mechanical and Aerospace Engineering

Missouri University of Science and Technology

ABSTRACT

Support Vector Machine (SVM) methods are widely used for classification and regression analyses. In many engineering applications, only one class of data is available, and then one-class SVM methods are employed. In reliability applications, the one class data available may be failure data since the data are recorded during reliability experiments when only failures occur. Different from the problems handled by existing one-class SVM methods, there is a bias constraint in the SVM model in this work because the constraint comes from the probability of failure estimated from the failure data. In this study, a new one-class SVM regression method is proposed to accommodate the bias constraint. The one class of failure data is maximally separated from a hypersphere whose radius is determined by the known probability of failure. The proposed SVM method allows for the generation of regression models that directly link the states of failure modes with design variables, and this makes it possible to obtain the joint probability density of all the component states of an engineering system, resulting in a more accurate prediction of system reliability during the design stage. Two examples are given to demonstrate the effectiveness of the new one-class SVM method.

1. INTRODUCTION

Support vector machine (SVM) was originally developed for classifying data from two different classes [1-3]. Two-class SVM methodologies obtain an optimal decision boundary by maximizing the margin between the training patterns. More specifically, given a data set composed of points from two different classes, an optimal boundary is built in the form of a hyperplane or hypersurface defined by the maximum margin between the points and the boundary, and the points on the maximum margin are the so-called support vectors.

SVM can be analyzed theoretically based on statistical learning theory and optimization methods, thus it outperforms other learning algorithms in many aspects. The advantage of SVM is attributed to its essence based on the principle of the maximal margin [4], the dual theory, and the kernel trick, which enable SVM to solve machine learning problems with only limited training points. It overcomes traditional difficulties due to the curse of dimensionality and over-fitting. This makes SVM highly successful and effective in real applications, and it thus has recently received considerable attention in various domains, such as pattern recognition [5-7], data mining [8], fault detection [9-11], space frame structures optimization [12], and reliability analysis [13-15].

Most traditional SVM methods assume more or less equally balanced data from both classes, and the decision boundary is therefore determined by the data belonging to different classes. However, when encountered with imbalanced data sets where the number of data from one of these two classes far outnumbers that from the other class or even equals to zero, the performance of the general two-class SVM may drop dramatically [16]. This situation is very common in real-world applications, especially in

certain domains such as reliability analysis and design. For example, to evaluate the reliability of a system or a component, designers may perform reliability testing repeatedly until the system or the component fails. They then record the failure data, such as sizes, loads, and the temperature at the time of failure. In this case, all the training points belong to only one class (failure). Due to the need of dealing with one-class data, many methods have been developed, and they have been used in applications such as novelty detection [17], document classification [18], and disease diagnosis [19].

The existing one-class SVM methods creates the optimal hyperplane (decision boundary) with a weight vector (normal vector) and a bias (intercept), which determine the orientation and location of the hyperplane, respectively. Due to the regularization of the optimization model, only the weight vector is actually to be determined, and the bias is treated separately after the weight vector is obtained. In some engineering applications, such as the aforementioned system reliability prediction, the bias is available, leaving only the weight vector unknown and to be determined.

To accommodate the known bias, in this work, we propose a new one-class SVM method. The constraint of the known bias geometrically forms a hypersphere centered at the origin. By maximizing the minimum distance between one-class training points and the hypersphere, the proposed method produces the optimal weight vector (orientation) of the desired hyperplane. The hyperplane function is thus determined by the obtained weight vector and the known bias. Since the hyperplane function explicitly defines the decision boundary which classifies the training points, it could then be used for further analysis, such as the aforementioned system reliability estimation, where the hyperplane function is actually the reconstructed computational model of the component.

The rest of the paper is organized as follows. In Section 2, we briefly review the basic methodologies, including the general SVM and one-class SVM. Section 3 introduces the proposed one-class SVM algorithm with a bias constraint. The application of this new method to the system reliability analysis is discussed in Section 4. One mathematical example and a real-world engineering example are provided in Section 5, followed by conclusions and future work in Section 6.

2. METHODOLOGY REVIEW

The general support vector machine methods and one-class support vector machine are briefly reviewed in this section.

2.1 GENERAL SUPPORT VECTOR MACHINE METHODOLOGY

The general two-class SVM separates training points from two classes with a hyperplane [3], which is identified by maximizing the minimum distance from the hyperplane to the training points. We first review the case of linearly separable training points. Given a set of k training points $(\mathbf{x}_1, y_1), (\mathbf{x}_2, y_2), \dots, (\mathbf{x}_k, y_k)$, $\mathbf{x} \in R^n$, in which $\mathbf{x}_i = (x_{i1}, x_{i2}, \dots, x_{in})$, $i = 1, 2, \dots, k$, are training points, and y_i is the class label for \mathbf{x}_i . If the point belongs to the first class, $y_i = +1$; otherwise, $y_i = -1$. A hyperplane separating the training points into two classes is given by

$$g(\mathbf{X}) = \boldsymbol{\omega} \mathbf{X}^T + b = 0 \quad (1)$$

where $\boldsymbol{\omega}$ is a weight vector, and b is the bias. There exists only one optimal hyperplane, which maximizes the margin (or distance) between itself and the nearest training points

of each class. Then two parallel hyperplanes are obtained by this maximized margin and are shown in Figure 1. The shaded points passed by the two boundaries are called support vectors. The hyperplane in the center of the two boundary hyperplanes, represented by the dotted line, is the optimal separating hyperplane. Note that, no points locate between the boundaries hyperplanes.

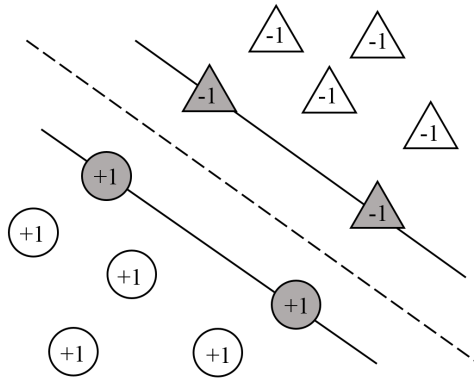

Figure 1 Marginal classifiers along with support vectors

The weight vector $\boldsymbol{\omega}$ is obtained by solving the following minimization problem:

$$\begin{cases} \min_{\boldsymbol{\omega}} \frac{1}{2} \boldsymbol{\omega} \boldsymbol{\omega}^T \\ \text{s.t. } y_i (\boldsymbol{\omega} \mathbf{x}_i^T + b) \geq 1, (i = 1, 2, \dots, k) \end{cases} \quad (2)$$

Eq. (2) shows a quadratic optimal problem, and it can be converted into a dual problem as follows:

$$\begin{cases} \max_{\boldsymbol{\lambda}} L = \sum_{i=1}^k \lambda_i - \frac{1}{2} \sum_{i,j=1}^k \lambda_i \lambda_j y_i y_j \mathbf{x}_i \mathbf{x}_j^T \\ \text{s.t. } \sum_{i=1}^k y_i \lambda_i = 0, \lambda_i \geq 0, (i = 1, 2, \dots, k) \end{cases} \quad (3)$$

where $\lambda_1, \lambda_2, \dots$, and λ_k are the Lagrange multipliers. According to the Karush-Kuhn-Tucker (KKT) conditions, only support vectors lead to $\lambda_i \neq 0$ [20]. After the Lagrange multipliers are obtained, the weight vector $\boldsymbol{\omega}$ is computed by

$$\boldsymbol{\omega} = \sum_{i=1}^k \lambda_i y_i \mathbf{x}_i \quad (4)$$

And the bias is then given by [21]

$$b = \frac{1}{k} \sum_{i=1}^k (y_i - \boldsymbol{\omega} \mathbf{x}_i^T) \quad (5)$$

The function of the hyperplane defined in Eq. (1) is rewritten as

$$g(\mathbf{X}) = \sum_{i=1}^k \lambda_i y_i \mathbf{x}_i \mathbf{X}^T + \frac{1}{k} \sum_{i=1}^k (y_i - \boldsymbol{\omega} \mathbf{x}_i^T) = 0 \quad (6)$$

As a decision boundary, $g(\mathbf{X})$ is used to determine the class labels of new samples. For a new point \mathbf{x} , if $g(\mathbf{x}) > 0$, it belongs to the class $y = +1$; otherwise, it belongs to $y = -1$.

The hyperplane performs well for linearly separable training points. For non-linearly separable training points, kernel tricks are adopted to map the input space into a high dimensional feature space through a transformation $\psi(\mathbf{X})$, making the classification problem linearly separable. Then a nonlinear optimal hyperplane in the input space, which is equivalent to the linear one in the feature space, is given by

$$f(\mathbf{X}) = \sum_{i=1}^k \lambda_i y_i K(\mathbf{x}_i, \mathbf{X}) + b \quad (7)$$

where $K(\mathbf{x}_i, \mathbf{X}) = K(\psi(\mathbf{x}_i), \psi(\mathbf{X}))$ is a kernel function [1, 3], and the bias b is given by

$$b = \frac{1}{k} \sum_{i=1}^k \left(y_i - \sum_{i,j=1}^k \lambda_i y_i K(\psi_i, \psi_j) \right) \quad (8)$$

2.2 GENERAL ONE-CLASS SUPPORT VECTOR MACHINE

The one-class SVM [22] is a variant of the general SVM and is used for only one class of training points. This method regards the training points available as belonging to the first class and the origin as being the second class. Then the general two-class SVM techniques could be employed. A decision boundary is built by maximizing the distance between training points and the origin, as shown in Figure 2.

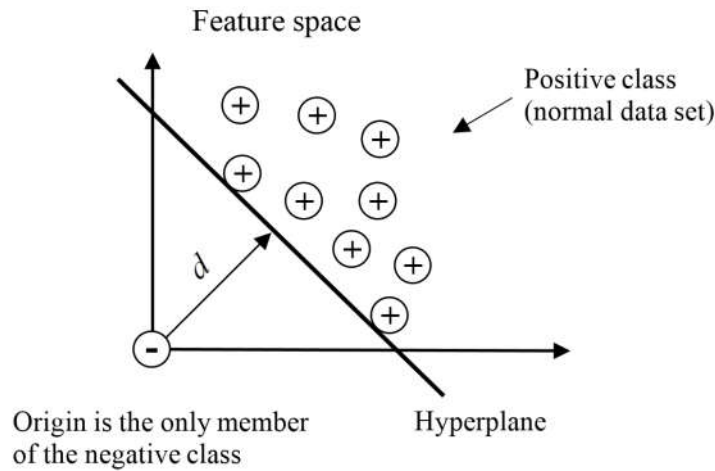

Figure 2 Basic principle of general one-class SVM

For m training points $(\mathbf{x}_1, y_1), (\mathbf{x}_2, y_2), \dots, (\mathbf{x}_m, y_m)$, $i = 1, 2, \dots, m$, $\mathbf{x} \in R^n$, which belong to the only class $y_i = +1$, the optimization model is given by

$$\begin{cases} \min_{\boldsymbol{\omega}, \xi, \rho} \frac{1}{2} \boldsymbol{\omega} \boldsymbol{\omega}^T + \frac{1}{m\nu} \sum_{i=1}^m \xi_i - \rho \\ \text{s.t. } \boldsymbol{\omega} \cdot \boldsymbol{\psi}(\mathbf{x}_i) + \xi_i - \rho \geq 0, \xi_i \geq 0, i = 1, 2, \dots, m \end{cases} \quad (9)$$

in which $\boldsymbol{\omega}$ and ρ are the to-be-determined weight vector and bias, respectively. The regularization variable $\nu \in (0, 1)$ indicates the maximum value of the fraction of training

data set errors, and $\xi=[\xi_1, \xi_2, \dots, \xi_m]$ is a vector of slack variables that allow point \mathbf{x}_i to locate on the other side of the optimal hyperplane.

With introducing Lagrange multipliers η_i and γ_i , the Lagrangian of the objective function in Eq. (9) is given by

$$L(\boldsymbol{\omega}, \boldsymbol{\xi}, \rho) = \frac{1}{2} \boldsymbol{\omega} \boldsymbol{\omega}^T + \frac{1}{mv} \sum_{i=1}^m \xi_i - \rho - \sum_{i=1}^m \gamma_i (\boldsymbol{\omega} \cdot \boldsymbol{\psi}(\mathbf{x}_i) + \xi_i - \rho) - \sum_{i=1}^m \eta_i \xi_i \quad (10)$$

With the appropriate kernel function $K(\mathbf{x}_i, \mathbf{X}) = K(\boldsymbol{\psi}(\mathbf{x}_i), \boldsymbol{\psi}(\mathbf{X}))$, the optimization model is then written in the dual form

$$\begin{cases} \min_{\boldsymbol{\gamma}} & \frac{1}{2} \sum_{i,j=1}^m \gamma_i \gamma_j K(\mathbf{x}_i, \mathbf{X}) \\ \text{s.t.} & 0 \leq \gamma_i \leq \frac{1}{mv}, \quad \sum_{i=1}^m \gamma_i = 1 \end{cases} \quad (11)$$

Note that when v approaches zero, most of the training points locate inside the estimated support. Then the upper bound of γ_i in (12) tends to infinity, making the second inequality constraint useless, which is similar to the hard margin algorithm used in two-class SVM. Since there is no constraints for bias ρ , the original optimization model can still be solved by assigning a large negative value to ρ [22].

Standard quadratic programming can be used to solve for $\gamma_1, \gamma_2, \dots$, and γ_m . The weight vector of the hyperplane is computed by

$$\boldsymbol{\omega} = \sum_{i=1}^m \gamma_i \boldsymbol{\psi}(\mathbf{x}_i) \quad (12)$$

And the bias is calculated by

$$b = \sum_{i,j=1}^m \gamma_i K(\mathbf{x}_i, \mathbf{x}_j) \quad (13)$$

With the determined ω and b , the decision boundary for one-class SVM is given by

$$f(\mathbf{X}) = \sum_{i=1}^m \gamma_i K(\mathbf{x}_i, \mathbf{X}) - \sum_{i,j=1}^m \gamma_i K(\mathbf{x}_i, \mathbf{x}_j) \quad (14)$$

3. A NEW ALGORITHM FOR ONE-CLASS SUPPORT VECTOR MACHINES WITH A BIAS CONSTRAINT

In this work, we propose a new one-class SVM method with a bias constraint. In the general SVM algorithm, although a bias exists, it is treated separately and does not appear in the optimization model. In the present problem, a bias exists and it is used to formulate a constraint function of the optimization model. The existence of the bias simplifies the optimization model.

The problem arises in the field of system reliability analysis. For the prediction of the reliability associated with a failure mode, repeated reliability testing is performed, and the failure data are recorded until failures occur. Then there is only one class of data. With the failure data, the reliability, which is the probability that the failure mode does not occur, can be estimated. It is this reliability that determines the bias. While more background information about reliability will be provided in Sec. 4, the new one-class SVM problem we are dealing with is summarized below.

Information available includes the following:

- A data set of m training points and responses is given by $(\mathbf{u}_1, y_1), (\mathbf{u}_2, y_2), \dots, (\mathbf{u}_m, y_m)$, $\mathbf{u} \in R^n$, $y_i = -1$, $i = 1, 2, \dots, m$. Note that different from the general SVM where training points are denoted by \mathbf{x} , here we use \mathbf{u} for training points because it is a common notation for reliability analysis where the

new method will be used. The data set is from reliability testing, and they may include load, dimensional, temperature, and other parameters that cause a failure. The corresponding response is the state of the component under testing, and $y_i = -1$ represents a failure state. There is only one class of data, which are data points in the failure region; we do not have the other class in the safe region with $y_i = +1$ (no occurrence of a failure).

- We know the shortest distance β from the origin to the domain to which the data set belongs. This distance comes from the known reliability.

The assumptions we make for the new SVM method are as follows:

- We assume that the boundary of the domain to which the data set belongs is a hyperplane. This assumption is valid for reliability applications where the First Order Reliability Method (FORM) [23] is applicable.
- The hyperplane is given by

$$Y = \beta + \alpha \mathbf{U}^T \quad (15)$$

where β is a constant, and α is a unit vector. In the reliability application concerned by this study, β is given and is determined by the reliability estimated from the training points, and α happens to be a unit vector.

Our task is to determine the unit vector α . In sum, our present problem is to find the optimal normal vector α , of a hyperplane given its distance to the origin being β and a data set $(\mathbf{u}_1, y_1), (\mathbf{u}_2, y_2), \dots, (\mathbf{u}_m, y_m)$, $\mathbf{u} \in R^n$. As demonstrated in Figure 3, the problem is to find a hyperplane tangent to a hypersphere with a radius of β , and the hyperplane also maximizes the distance from any training points to the hypersphere.

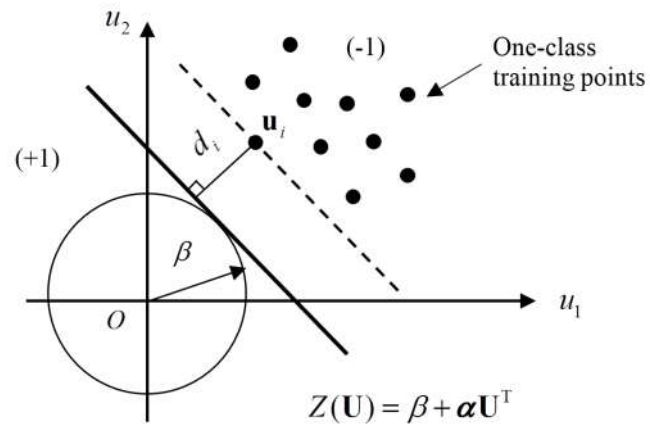

Figure 3 Basic principle of the proposed one-class SVM

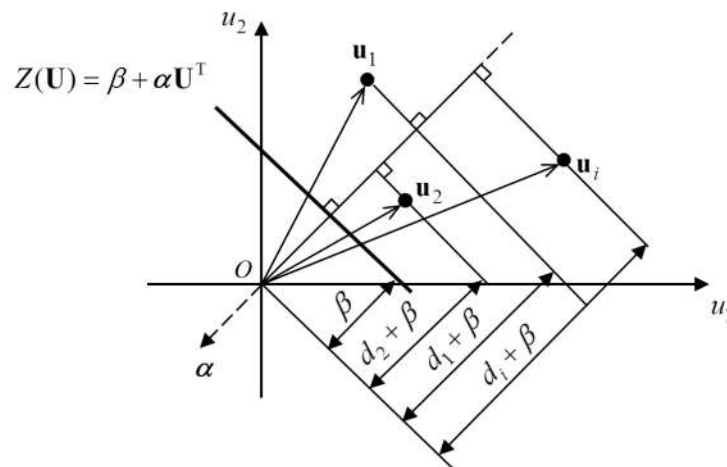

Figure 4 Geometric meaning of $d_i + \beta$

Denote the distance from \mathbf{u}_i to the hypersphere by d_i . We also define that points located in the negative region enables $Y < 0$; otherwise, $Y > 0$ holds. The minimum distance is given by

$$d = \min\{d_i\} = \min\left\{-\left(\beta + \alpha \mathbf{u}_i^T\right)\right\} \quad (16)$$

in which the negative sign indicates that the training points locate in the negative side of the hyperplane $Z(\mathbf{U})$, thereby making d positive. Since β is a known constant, d is actually determined by minimizing $d_i + \beta$, which is equal to $-\alpha \mathbf{u}_i^T$. Note that $d_i + \beta$ indicates the scalar projection of \mathbf{u}_i onto α . Since $\alpha \mathbf{u}_i^T$ is negative here, the direction of α is opposite to that of \mathbf{u}_i . The geometrical meaning of $d_i + \beta$ is shown in Figure 4.

To construct the optimal hyperplane, our task then becomes to find the maximum d , which can be obtained from the following optimization model

$$\begin{cases} \max_{\alpha, d} d \\ \text{s.t. } -(\beta + \alpha \mathbf{u}_i^T) \geq d, (i=1, 2, \dots, m) \end{cases} \quad (17)$$

This is the basic model of the proposed one-class SVM with a bias constraint determined by the given constant β . Let $h = d + \beta$, and Eq. (17) is rewritten as

$$\begin{cases} \max_{\alpha, h} h \\ \text{s.t. } -\alpha \mathbf{u}_i^T \geq h, (i=1, 2, \dots, m) \end{cases} \quad (18)$$

Set $\omega = \frac{\alpha}{h}$, we have $h = \frac{1}{\|\omega\|}$. Then, Eq. (18) becomes

$$\begin{cases} \max_{\omega} \frac{1}{\|\omega\|} \\ \text{s.t. } \omega \mathbf{u}_i^T \leq -1, (i=1, 2, \dots, m) \end{cases} \quad (19)$$

which is equivalent to the constrained quadratic programming problem as follows:

$$\begin{cases} \min_{\omega} \frac{1}{2} \omega \omega^T \\ \text{s.t. } \omega \mathbf{u}_i^T + 1 \leq 0, (i=1, 2, \dots, m) \end{cases} \quad (20)$$

With Lagrange multipliers $\lambda_i \geq 0$, the Lagrangian function is given by

$$L(\boldsymbol{\omega}) = \frac{1}{2} \boldsymbol{\omega} \boldsymbol{\omega}^T - \sum_{i=1}^m \lambda_i (-\boldsymbol{\omega} \mathbf{u}_i^T - 1) \quad (21)$$

According to the KKT conditions, we have

$$\frac{\partial L}{\partial \boldsymbol{\omega}} = 0 \rightarrow \boldsymbol{\omega} = -\sum_{i=1}^m \lambda_i \mathbf{u}_i \quad (22)$$

Submitting Eq. (22) into Eq. (21), the Lagrangian function is rewritten as

$$\begin{aligned} L(\boldsymbol{\omega}) &= \frac{1}{2} \sum_{i,j=1}^m \lambda_i \lambda_j \mathbf{u}_i \mathbf{u}_j^T - \sum_{i=1}^m \lambda_i \left(\left(\sum_{i=1}^m \lambda_i \mathbf{u}_i \right) \mathbf{u}_i^T - 1 \right) \\ &= \frac{1}{2} \sum_{i,j=1}^m \lambda_i \lambda_j \mathbf{u}_i \mathbf{u}_j^T - \sum_{i,j=1}^m \lambda_i \lambda_j \mathbf{u}_i \mathbf{u}_j^T + \sum_{i=1}^m \lambda_i \\ &= \sum_{i=1}^m \lambda_i - \frac{1}{2} \sum_{i,j=1}^m \lambda_i \lambda_j \mathbf{u}_i \mathbf{u}_j^T \end{aligned} \quad (23)$$

Thus, the dual form of the quadratic programming problem in Eq. (20) is given by

$$\begin{cases} \max_{\boldsymbol{\lambda}} & \sum_{i=1}^m \lambda_i - \frac{1}{2} \sum_{i,j=1}^m \lambda_i \lambda_j \mathbf{u}_i \mathbf{u}_j^T \\ \text{s.t.} & \lambda_i \geq 0, \quad \forall i = 1, 2, \dots, m \end{cases} \quad (24)$$

Solving the optimization model in Eq. (24) yields the Lagrange multipliers $\lambda_1, \lambda_2, \dots, \lambda_m$. Plugging them into Eq. (22) produces the weight vector $\boldsymbol{\omega}$. The unit vector $\boldsymbol{\alpha}$ is then recovered by $\boldsymbol{\alpha} = \frac{\boldsymbol{\omega}}{\|\boldsymbol{\omega}\|}$, which thereby constructs the function $Z(\mathbf{U})$ for the hyperplane. Similar to the general one-class SVM algorithm, the training points satisfying $\{\mathbf{x}_i : i \in 1, 2, \dots, m, \lambda_i > 0\}$ are support vectors by which the optimal hyperplane is finally determined. With the known bias β and the acquired normal vector $\boldsymbol{\alpha}$, the function of the hyperplane is determined by

$$Y = Z(\mathbf{U}) = \beta + \boldsymbol{\alpha} \mathbf{U}^T \quad (25)$$

which is a decision boundary defining the domain of the one-class data set and could then be used to predict the state of a new sample. Plug a new sample \mathbf{u}_N into Eq. (25). If $Y < 0$, the new sample belongs to the same class as that of the training points, and $y = -1$; otherwise, it is outside the domain of the training points and belongs to the class of $y = +1$.

The proposed one-class SVM algorithm can easily accommodate the bias constraint, which is derived from the given one-class data set. The new algorithm only focuses on this data set without considering the origin as the second class. The optimal hyperplane is constructed based on the hard margin associated with the bias constraint. Specifically, if we regard seeking such an optimal hyperplane as a dynamic process, the general one-class SVM technique attempts to move the hyperplane to the desired position through rotations and translations. On the other hand, in the proposed method the hyperplane only rotates around the origin while keeping tangent to the hypersphere with a radius of β . In other words, the hyperplane rolls without slipping on the hypersphere. Also, since no slack variables ξ and regularization parameter ν are introduced, the constraints for the optimization model are relatively simple thereby increasing the computation efficiency.

4. APPLICATION OF THE NEW ONE-CLASS SVM IN SYSTEM RELIABILITY PREDICTION

System reliability is the probability of a system working normally without failures. Since the system state (safe or failed) is determined by the states of its components and it may be hard to predict the system reliability directly, the system reliability is usually

estimated based on component states. Physics-based methods [23-26] and statistics-based methods [27-29] are two possible choices for component reliability analysis. We first briefly review the concepts and basic techniques of the two kinds of reliability methods and then explain how the proposed algorithm works for system reliability analysis.

4.1 PHYSICS-BASED RELIABILITY METHODS

Physics-based reliability methods use computational models to estimate reliability, which predict the component failure state based on physics principles. The computational model is called a limited-state function, denoted by $y = g(\mathbf{X})$, where \mathbf{X} is a vector of basic random variables, which are root variables that affect the state of the failure mode, such as component shape and dimensions, loadings, material properties, and environmental factors; y is the state variable. For each failure mode, a limit-state function is built. If $y > 0$, the state is safe. Otherwise, a failure occurs. The reliability with respect to the failure mode is given by

$$R = \Pr\{\text{state} = \text{safe}\} = \Pr\{y = g(\mathbf{X}) > 0\} \quad (26)$$

The probability of failure p_f is given by

$$p_f = \Pr\{\text{state} = \text{failed}\} = \Pr\{y = g(\mathbf{X}) < 0\} = 1 - R \quad (27)$$

Since it is hard to compute Eq. (27) analytically, many approximation methods have been proposed, including FORM [23, 30], the Second Order Reliability Method (SORM) [31], the Saddlepoint Approximation method (SPA) [32], and Monte Carlo Simulation (MCS) [33]. In this work, we adopt FORM to approximate a linear form of

$g(\mathbf{X})$, then the component probability of failure could be easily estimated. The procedure of FORM is briefly summarized in the following three steps.

Step1: Transform random variables into standard normal variables

Assume that all the random variables in the X-space are independent. The original random variables $\mathbf{X} = (X_1, X_2, \dots, X_n)$ are transformed into standard normal random variables $\mathbf{U} = (U_1, U_2, \dots, U_n)$ in the U-space. The transformation is given by [34]

$$F_i(x_i) = \Phi(u_i) \quad (i = 1, 2, \dots, n) \quad (28)$$

where $F_i(\cdot)$ and $\Phi(\cdot)$ are the cumulative distribution functions (CDF) of X_i and a standard normal variable, respectively. The transformation could also be given in the form of

$$x_i = T(u_i) = F^{-1}(\Phi(u_i)) \quad (i = 1, 2, \dots, n) \quad (29)$$

in which $T(\cdot)$ denotes the transformation function.

Step 2: Approximate a linear limit-state function

After the transformation, the component probability of failure is computed by

$$p_f = \Pr\{g(T(\mathbf{U})) < 0\} \quad (30)$$

FORM then yields an approximated linear limit-state function [23] given by

$$Z(\mathbf{U}) = \beta + \boldsymbol{\alpha}\mathbf{U}^T \quad (31)$$

Step 3: Compute p_f

With the new limit-state function $Z(\mathbf{U})$ in Eq. (31), which is a linear combination of standard normal random variables, p_f is calculated by

$$p_f = \Pr\{Z(\mathbf{U}) < 0\} = \Phi(-\beta) \quad (32)$$

4.2 STATISTICS-BASED RELIABILITY METHODS

A statistics-based method relies on field or testing data related to failures of a component. The component reliability R is estimated by

$$R = \Pr \{ \text{state} = \text{safe} \} \approx \frac{N - N_f}{N} \quad (33)$$

where $\Pr(\cdot)$ denotes a probability, N_f is the number of failed component, and N is the total number of components.

SVM is widely used with the statistics-based method which creates a reliability model using the provided training data with no need for physical principle of the component. Note that the recorded field or testing data belong to either the safe region or failure region. SVM can therefore identify the safety-failure boundary by solving a binary classification problem [35]. As is mentioned above, the general two-class SVM is only available for cases where two classes of training data are provided.

4.3 APPLICATION OF THE NEW METHOD

We now discuss how to use the proposed one-class SVM approach to achieve a linear decision boundary (limit-state function) if only a one-class training data set is given. The details are as follows.

We still use $y = g(\mathbf{X})$ as the component limit-state function, and the original random variables, denoted by $\mathbf{X} = (X_1, X_2, \dots, X_n)$ are independent. The counterpart of \mathbf{X} in the U-space, denoted by $\mathbf{U} = (U_1, U_2, \dots, U_n)$, are standard normal random variables. Given a data set of m training points at failure states as follows:

$$(\mathbf{x}_1, y_1), (\mathbf{x}_2, y_2), \dots, (\mathbf{x}_m, y_m), \quad \mathbf{x} \in R^n, \quad y_i = -1, \quad i = 1, 2, \dots, m$$

The bias β is known, which comes from the component reliability estimated by the supplier using the given training points.

Step1: Transform \mathbf{X} into \mathbf{U}

Similar to FORM, the transformation is given by

$$x_j = T(u_j) = F^{-1}(\Phi(u_j)), \quad j = 1, 2, \dots, n \quad (34)$$

Step 2: Approximate a linear limit-state function based on one-class SVM

According to the proposed one-class SVM discussed in Section 3, the optimal normal orientation of the to-be-determined decision boundary is given by $\boldsymbol{\omega} = -\sum_{i=1}^m \lambda_i \mathbf{u}_i$, in which λ_i is available after solving the dual form of the Lagrangian in Eq. (24), and \mathbf{u}_i is obtained in Step 1. Since the bias β is also available, the linear form of the component limit-state function is then obtained by

$$Z(\mathbf{U}) = \beta + \boldsymbol{\alpha} \mathbf{U} \quad (35)$$

in which $\boldsymbol{\alpha} = \frac{\boldsymbol{\omega}}{\|\boldsymbol{\omega}\|}$.

Since β is known, there is no need to recalculate component reliability using $Z(\mathbf{U})$. $Z(\mathbf{U})$ is actually used for the system reliability prediction by integrating with other available limit-state functions from FORM. Next, we will discuss how to do so.

4.4 SYSTEM RELIABILITY ANALYSIS

System reliability could be estimated either by a physics-based approach, a statistics-based approach, or the integration of both. Predicting system reliability is an important task, especially for systems with outsourced components. Outsourcing is a

common practice because more and more industrial firms function like system integrators with numerous components outsourced [36], resulting in urgent demand for integrating both statistics- and physics-based approaches. Accurately predicting the system reliability requires complete design information for both in-house and outsourced components, such as the limit-state functions and distributions of basic random variables. System designers may know everything about the in-house components; however, the design details of outsourced components are usually unavailable since they are proprietary to outside suppliers. This makes it hard to directly use traditional methods for system reliability analysis [37]. To address this issue, the proposed one-class SVM method with a bias constraint is used to reconstruct the limit-state functions for outsourced components, thereby integrating the new algorithm with physic-based methods for accurate system reliability prediction.

A proof-of-concept method [38] was recently developed, and it validates the feasibility of this study. This work is an extension of the algorithm proposed in [38] with a bias constraint derived from the data set provided by the component supplier, such as the reliability data at failure states. We now introduce how to use the proposed method for system reliability prediction. The application scope is summarized as follows:

- The system has m components (failure modes) and $m \geq 2$.
- Component states are dependent.
- There are two types of components: 1) Type I components, whose probabilities of failure are obtained through physics-based methods, have available limit-state functions $g_i^1(\cdot)$, ($i = 1, 2, \dots, m_1$), where m_1 is the component number. 2) For the other m_2 ($m_2 = m - m_1$) type II components, no limit-state functions are available,

but the data set of training points from fields or testing is provided, and the probabilities of failure are evaluated using a statistics-based method.

- Assume the system is series.
- Distributions of all basic random variables are known.

For a Type I component, the limit-state functions in the U-space are transformed by

$$g_i^I(\mathbf{X}) \xrightarrow{\mathbf{x} \rightarrow T(\mathbf{U})} Z_i^I(\mathbf{U}) = \beta_i^I + \boldsymbol{\alpha}_i^I \mathbf{U}^T \quad (i = 1, 2, \dots, m_1) \quad (36)$$

For Type II components, the limit-state functions produced by the proposed one-class SVM is given in the form of

$$Z_j^{II}(\mathbf{U}) = \beta_j^{II} + \frac{\boldsymbol{\omega}_j}{\|\boldsymbol{\omega}_j\|} \mathbf{U}^T = \beta_j^{II} + \boldsymbol{\alpha}_j^{II} \mathbf{U}^T \quad (j = m_1 + 1, m_1 + 2, \dots, m) \quad (37)$$

Since the components of \mathbf{U} follow a standard normal distribution, the reconstructed limit-state functions $Z_i^I(\mathbf{U})$ and $Z_j^{II}(\mathbf{U})$ also follow normal distributions $Z_i^I(\mathbf{U}) \sim N(\mu_i^I, \sigma_i^I)$ and $Z_j^{II}(\mathbf{U}) \sim N(\mu_j^{II}, \sigma_j^{II})$, respectively, in which $\mu_i^I = \beta_i^I$ and $\mu_j^{II} = \beta_j^{II}$ are their vectors of means, and the covariance of $Z_i^I(\mathbf{U})$ and $Z_j^{II}(\mathbf{U})$ is ρ_{ij} , which will be given in Eq. (40). Thus, the joint PDF of $Z_i^I(\mathbf{U})$ and $Z_j^{II}(\mathbf{U})$, denoted by $\phi_{\mathbf{U}}(\mathbf{u})$, is actually the PDF of a multivariate normal distribution with a mean vector $\boldsymbol{\mu}$ and a covariance matrix $\boldsymbol{\Sigma}$. $\boldsymbol{\mu}$ is given by

$$\boldsymbol{\mu} = (\beta_1^I, \beta_2^I, \dots, \beta_{m_1}^I, \beta_{m_1+1}^{II}, \beta_{m_1+2}^{II}, \dots, \beta_m^{II}) \quad (38)$$

in which β_i^I ($i = 1, 2, \dots, m_1$) is obtained from FORM, and β_j^{II} ($j = m_1 + 1, m_1 + 2, \dots, m$) is calculated by $\beta_j^{II} = -\Phi^{-1}(p_{fj})$.

And Σ is given by

$$\Sigma = \begin{bmatrix} 1 & \rho_{12} & \cdots & \rho_{1m} \\ \rho_{21} & 1 & & \rho_{2m} \\ \vdots & \vdots & \ddots & \vdots \\ \rho_{m1} & \rho_{m2} & \cdots & 1 \end{bmatrix}_{m \times m} \quad (39)$$

in which ρ_{ij} is the correlation coefficient between the i -th and j -th components and is computed by

$$\rho_{ij} = \rho_{ji} = \begin{cases} \boldsymbol{\alpha}_i^I (\boldsymbol{\alpha}_j^I)^\top, & i < j \leq m_1 \\ \boldsymbol{\alpha}_i^I (\boldsymbol{\alpha}_j^{\text{II}})^\top, & i \leq m_1 < j \\ \boldsymbol{\alpha}_i^{\text{II}} (\boldsymbol{\alpha}_j^{\text{II}})^\top, & m_1 < i < j \end{cases} \quad (40)$$

From Eq. (37), we find $\boldsymbol{\alpha}_j^{\text{II}} = \frac{\boldsymbol{\omega}_j}{\|\boldsymbol{\omega}_j\|}$ ($j = m_1 + 1, m_1 + 2, \dots, m$), in which $\boldsymbol{\alpha}_j^{\text{II}}$ has the same direction as $\boldsymbol{\omega}_j$.

With $\boldsymbol{\mu}$ and Σ available, the complete joint PDF $\phi_{\mathbf{U}}(\mathbf{u})$ is also available and is given by

$$\phi_{\mathbf{U}}(\mathbf{u}) = \frac{1}{\sqrt{(2\pi)^n |\Sigma|}} \exp\left(-\frac{1}{2}(\mathbf{u} - \boldsymbol{\mu})^\top \Sigma^{-1}(\mathbf{u} - \boldsymbol{\mu})\right) \quad (41)$$

The probability of system failure is computed by

$$p_{fs} = \Pr\left(\bigcup_{i=1}^{m_1} Z_i^I(\mathbf{U}) < 0 \cup \bigcup_{j=m_1+1}^m Z_j^{\text{II}}(\mathbf{U}) < 0\right) \quad (42)$$

And the system reliability is

$$R_s = \Pr\left(\bigcap_{i=1}^{m_1} -Z_i^I(\mathbf{U}) < 0 \cap \bigcap_{j=m_1+1}^m -Z_j^{\text{II}}(\mathbf{U}) < 0\right) = \int_{\Omega} \phi_{\mathbf{U}}(\mathbf{u}) d\mathbf{u} \quad (43)$$

where Ω is the system safe region defined by

$$\Omega = \left\{ \mathbf{U} \mid -Z_i^I(\mathbf{U}) < 0, -Z_j^{II}(\mathbf{U}) < 0 \ (i = 1, 2, \dots, m_1; j = m_1 + 1, m_1 + 2, \dots, m) \right\} \quad (44)$$

Thus, R_s can be easily evaluated by solving the integral in Eq. (43), and the probability of system failure is then $p_{fs} = 1 - R_s$. A schematic diagram of the proposed method is given in Figure 5.

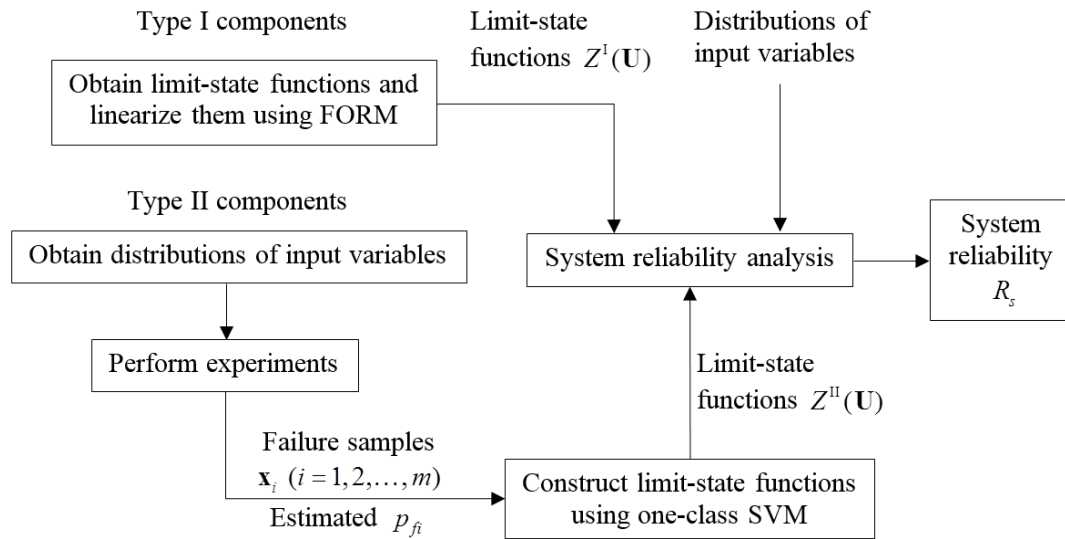

Figure 5 Schematic diagram of the proposed method

The proposed method makes the following contributions to reliability analysis: 1) At the component level, it provides a new way to approximate component limit-state functions with only estimated probabilities of failure and limited field or testing failure data. 2) At the system level, since the provided component limit-state functions is linearized using FORM, which produces the same form as the approximated limit-state

functions obtained from the proposed one-class SVM, system reliability analysis could be easily conducted. 3) It improves the accuracy of the system reliability prediction because it accounts for the dependency between components automatically. 4) It dramatically reduces the computational cost due to the linear forms of all the limit-state functions.

5. EXAMPLES

Two examples are used to demonstrate the effectiveness and accuracy of the proposed method. Example 1 is a numerical problem showing how to apply the proposed method step by step. Example 2 is an engineering problem concerned with a cantilever beam subjected to different kinds of loads, thereby resulting in multiple failure modes.

5.1 NUMERICAL EXAMPLE

A system is comprised of two physical components, and each has one failure mode. If either of component fails, the system fails. There are two independent basic random variables $\mathbf{X} = (X_1, X_2)$, in which $X_1 \sim N(12, 1^2)$ and $X_2 \sim N(40, 2^2)$. The limit-state function of the first component is available and is given by

$$g_1^1(\mathbf{X}) = -260 + 8.5X_1 + 5.2X_2 \quad (45)$$

Thus, the component is a Type-I component.

FORM produces a linear model, which is given by

$$Z_1^1(\mathbf{U}) = \beta_1^1 + \boldsymbol{\alpha}_1^1 \mathbf{U}^T = 3.7225 + 0.6328U_1 + 0.7743U_2 \quad (46)$$

in which $\beta_1^1 = 3.7225$ and $\boldsymbol{\alpha}_1^1 = (0.6328, 0.7743)$.

Component two is a Type II component since no model is available. The probability of failure $p_{f_2} = 2.5517 \times 10^{-5}$ is estimated by a statistics-based reliability method using the recorded testing points, which come from reliability testing.

Although no model is available, to analyze the accuracy, we assume the true model in the X-space is given by

$$g_2^{\text{II}(\text{true})}(\mathbf{X}) = -325 + 5.6X_1 + 8.2X_2 \quad (47)$$

The linear model in the U-space is

$$Z_2^{\text{II}(\text{true})}(\mathbf{U}) = 4.0508 + 0.3231U_1 + 0.9463U_2 \quad (48)$$

We then use computer experiments to mimic the physical reliability testing. With MCS and the model in Eq. (47), we generate a set of training points and transform them into the U-space as shown in Table 1. We also assume that the value of p_{f_2} given above is known and is equal to the one estimated using Eq. (47).

Assume that the linear model for component two is given by

$$Z_2^{\text{II}}(\mathbf{U}) = \beta_2^{\text{II}} + \boldsymbol{\alpha}_2^{\text{II}} \mathbf{U}^T \quad (49)$$

in which β_2^{II} is calculated by $\beta_2^{\text{II}} = -\Phi^{-1}(p_{f_2}) = 4.0508$, and $\boldsymbol{\alpha}_2^{\text{II}}$ is the to-be-determined unit vector. Using the proposed one-class SVM method, we solve for $\boldsymbol{\alpha}_2^{\text{II}}$ by

$$\begin{cases} \max_{\boldsymbol{\lambda}} & \sum_{i=1}^{10} \lambda_i - \frac{1}{2} \sum_{i,j=1}^{10} \lambda_i \lambda_j \mathbf{u}_i \mathbf{u}_j^T \\ \text{s.t.} & \lambda_i \geq 0, \quad \forall i = 1, 2, \dots, 10 \end{cases} \quad (50)$$

where $\mathbf{u}_1 = (-1.4342, -3.8442)$, $\mathbf{u}_2 = (-2.1810, -4.6721)$, \dots , and $\mathbf{u}_{10} = (-0.8223, -4.1205)$ as shown in Table 1.

Table 1 Training points

No.	\mathbf{u}	
	U_1	U_2
1	-1.4342	-3.8442
2	-2.1810	-4.6721
3	-0.5057	-4.1478
4	-1.3443	-3.9958
5	-1.9988	-3.9879
6	-1.7684	-3.7517
7	-2.5285	-3.6413
8	-1.9114	-3.8673
9	-3.0726	-3.3558
10	-0.8223	-4.1205

After solving the above model, we have the Lagrange multipliers $\boldsymbol{\lambda} = (0.0459, 0, 0.0099, 0, 0, 1.734 \times 10^{-4}, 0, 0, 0, 0)$, and the three support vectors \mathbf{u}_1 , \mathbf{u}_3 and \mathbf{u}_6 marked by the circles in Figure 6 are determined by the non-zero multipliers. Plugging $\boldsymbol{\lambda}$, \mathbf{u}_1 , \mathbf{u}_2 , \dots , and \mathbf{u}_{10} into $\boldsymbol{\omega}_2 = -\sum_{i=1}^{10} \lambda_i \mathbf{u}_i$, we obtain the weight vector $\boldsymbol{\omega}_2 = (0.0712, 0.2182)$, resulting in a unit vector $\boldsymbol{\alpha}_2^{\text{II}} = \frac{\boldsymbol{\omega}_2}{\|\boldsymbol{\omega}_2\|} = (0.3101, 0.9507)$. Thus the linear model of component two is reconstructed by

$$Z_2^{\text{II}}(\mathbf{U}) = \beta_2^{\text{II}} + \boldsymbol{\alpha}_2^{\text{II}} \mathbf{U}^T = 4.0508 + 0.3101U_1 + 0.9507U_2 \quad (51)$$

The corresponding optimal hyperplane is also shown in Fig 6, separating the one class training points (data set at failure state) clearly from the circle with a radius of β_2^{II} .

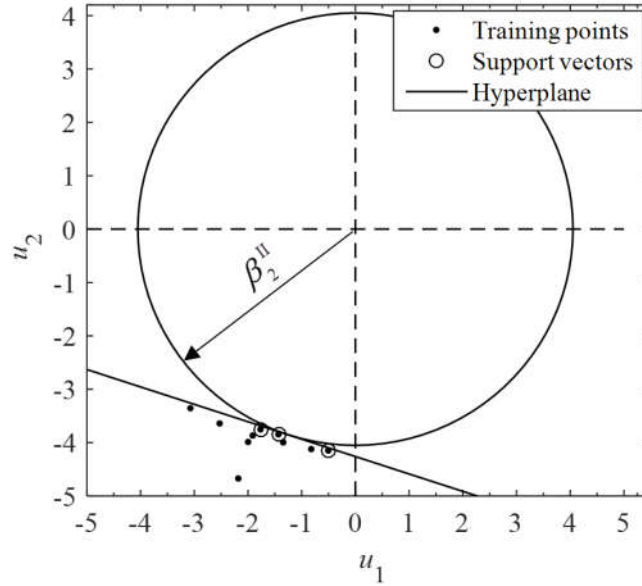

Figure 6 Support vectors and optimal hyperplane

The approximated limit-state function in Eq. (51) is very close to the true one given in Eq. (48), thereby leading to high accuracy of system reliability prediction, the details of which are shown below.

Since the components of \mathbf{U} follow standard normal distributions, the two dimensional random vector $\mathbf{Z} = [Z_1^{\text{I}}(\mathbf{U}), Z_2^{\text{II}}(\mathbf{U})]$ follows a multivariate normal distribution with the joint PDF

$$\phi_{\mathbf{u}}(\mathbf{u}) = \frac{1}{\sqrt{(2\pi)^2 |\boldsymbol{\Sigma}|}} \exp\left(-\frac{1}{2}(\mathbf{u} - \boldsymbol{\mu})^{\text{T}} \boldsymbol{\Sigma}^{-1}(\mathbf{u} - \boldsymbol{\mu})\right) \quad (52)$$

where the mean vector $\boldsymbol{\mu}$ and covariance matrix $\boldsymbol{\Sigma}$ are given by

$$\boldsymbol{\mu} = (\beta_1^I, \beta_2^{II}) = (3.7225, 4.0508) \quad (53)$$

$$\boldsymbol{\Sigma} = \begin{bmatrix} 1 & \rho_{12} \\ \rho_{21} & 1 \end{bmatrix} = \begin{bmatrix} 1 & \boldsymbol{\alpha}_1^I (\boldsymbol{\alpha}_2^{II})^T \\ \boldsymbol{\alpha}_1^I (\boldsymbol{\alpha}_2^{II})^T & 1 \end{bmatrix} = \begin{bmatrix} 1 & 0.9324 \\ 0.9324 & 1 \end{bmatrix} \quad (54)$$

The system reliability is calculated by

$$R_s = \Pr(-Z_1^I(\mathbf{U}) < 0 \cap -Z_2^{II}(\mathbf{U}) < 0) = \int_{\Omega} \phi_{\mathbf{U}}(\mathbf{u}) d\mathbf{u} \quad (55)$$

where Ω is the system safe region defined by

$$\Omega = \{\mathbf{U} \mid -Z_1^I(\mathbf{U}) < 0, -Z_2^{II}(\mathbf{U}) < 0\} \quad (56)$$

Plugging Eq. (52) into Eq. (55), we have $p_{f_s} = 1 - R_s = 1.0537 \times 10^{-4}$.

We now discuss the case where the traditional system reliability method is used and then compare the results from both methods. The traditional method [39] assumes that the states of all the components are independent. Then the system reliability is calculated by

$$R_S = \prod_{i=1}^m R_i \quad (57)$$

where R_i is the reliability of the i -th component. The result is given in Table 2 on the ‘‘Independence Assumption Method’’ column. Although this method is easy to use and sometimes effective, it may produce large errors when the components are highly dependent.

To verify the accuracy, we also use the true limit-state functions $g_1^I(\mathbf{X})$ and $g_2^{II(\text{true})}(\mathbf{X})$ in Eqs. (45) and (47) to evaluate the system reliability based on FORM and consider this value as a benchmark. The result obtained is 1.0478×10^{-4} . Table 2 shows all the results from different methods. The independence assumption method has a large error of 18.46%, which is due to the neglected strong correlation indicated by $\rho_{12} = 0.9324$. The proposed method produces an error of only 0.56%, which shows much higher accuracy.

Table 2 Results of system reliability from different methods

	Proposed Method	Independence Assumption Method	True Value
P_{fs}	1.0537×10^{-4}	1.2413×10^{-4}	1.0478×10^{-4}
Error (%)	0.56	18.46	—

5.2 ENGINEERING EXAMPLE

A cantilever beam is subject to moments M_1 and M_2 , forces Q_1 and Q_2 , and distributed loads denoted by (q_{L1}, q_{R1}) and (q_{L2}, q_{R2}) as shown in Figure 7. Assume that M_1 , M_2 , and Q_1 ; the dimensions variables a_1 , a_2 , and b_1 ; the yield strength S_a ; and the allowable shear stress τ_a are basic random variables, which are assumed independent and are listed in Table 3. Deterministic parameters are listed in Table 4.

The cantilever beam fails due to three failure modes, and each is considered as a component, thus the reliability of the beam is regarded as a system reliability.

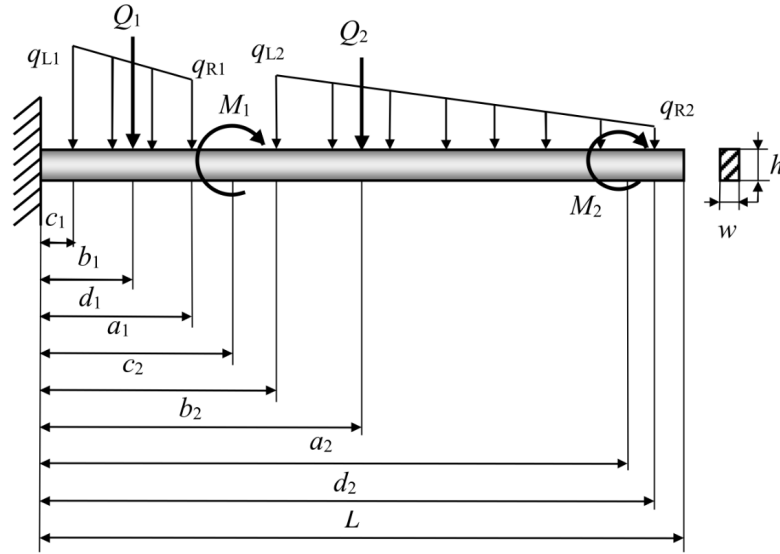

Figure 7 A cantilever beam system

The first failure mode is caused by excessive normal stress, and its limit-state function is known and is given by

$$g_1^I(\mathbf{X}) = S_a - \frac{6M}{wh^2} \quad (58)$$

in which M is the bending moment at the root calculated by

$$M = \sum_{i=1}^2 M_i + \sum_{i=1}^2 F_i b_i + \sum_{i=1}^2 q_{Li} (d_i - c_i)(d_i + c_i) / 2 + \sum_{i=1}^2 [(q_{Ri} - q_{Li})(d_i - c_i) / 2][c_i + 2(d_i - c_i) / 3] \quad (59)$$

Since the limit-state function is provided, this failure mode is treated as a Type I component. The second failure mode comes from the excessive shear stress with a known limit-state function given by

$$g_2^I(\mathbf{X}) = \tau_a - \tau_{\max} \quad (60)$$

in which τ_a is the allowable shear stress, and τ_{\max} is the maximal shear stress given by

$$\tau_{\max} = \frac{3}{2wh} \left(\sum_{i=1}^2 F_i + \sum_{i=1}^2 q_{Li} (d_i - c_i) + \sum_{i=1}^2 \frac{(q_{Ri} - q_{Li})(d_i - c_i)}{2} \right) \quad (61)$$

Similarly, this failure mode is also a Type I component.

Table 3 Basic random variables

	Random variables	Distribution
X_1	$M_1(\text{Nm})$	$N(50 \times 10^3, (2 \times 10^3)^2)$
X_2	$M_2(\text{Nm})$	$N(30 \times 10^3, (2 \times 10^3)^2)$
X_3	$a_1(\text{m})$	$N(1.5, 0.005^2)$
X_4	$a_2(\text{m})$	$N(4.5, 0.005^2)$
X_5	$Q_1(\text{N})$	$N(65 \times 10^3, (13 \times 10^3)^2)$
X_6	$b_1(\text{m})$	$N(0.7, 0.005^2)$
X_7	$S_a(\text{Pa})$	$N(62.5 \times 10^6, (1 \times 10^6)^2)$
X_8	$\tau_a(\text{Pa})$	$N(3.6 \times 10^6, (1 \times 10^5)^2)$

The third failure mode (FM3) is due to the excessive deflection with an unknown limit-state function. It is therefore a Type II component. The probability of failure p_{f3} due to this failure mode is then evaluated using statistics-based methods with training points. Note that the training points used in this example actually come from computer simulation, since it is hard for us to perform real physical experiments due to lack of measuring devices. Assume the true limit-state function for FM3 is

$$g_3^{\text{II}(\text{true})}(\mathbf{X}) = v_a - v_{\max} \quad (62)$$

in which $v_a = 8.4 \text{ mm}$ is the allowable deflection, and v_{\max} is the maximal tip deflection.

Table 4 Deterministic parameters

	Parameters	Values
1	$Q_2(\text{N})$	30×10^3
2	$b_2(\text{m})$	2.5
3	$q_{L1}(\text{N/m})$	30×10^3
4	$q_{L2}(\text{N/m})$	20×10^3
5	$c_1(\text{m})$	0.25
6	$c_2(\text{m})$	1.75
7	$q_{R1}(\text{N/m})$	20×10^3
8	$q_{R2}(\text{N/m})$	1×10^3
9	$d_1(\text{m})$	1.25
10	$d_2(\text{m})$	4.75
11	$L(\text{m})$	5.1
12	$w(\text{m})$	0.204
13	$h(\text{m})$	0.403

The deflection v_{\max} can be computed by

$$\begin{aligned}
v_{\max} = & \frac{1}{EI} \left[\frac{ML^2}{2} + \frac{BL^3}{2} + \sum_{i=1}^2 \frac{M_i(L-a_i)^2}{2} - \sum_{i=1}^2 \frac{F_i(L-b_i)^3}{6} \right] \\
& + \frac{1}{EI} \left[-\sum_{i=1}^2 \frac{q_{Li}(L-c_i)^4}{24} - \sum_{i=1}^2 \frac{(q_{Ri}-q_{Li})(L-c_i)^5}{120(d_i-c_i)} + \sum_{i=1}^2 \frac{q_{Ri}(L-d_i)^4}{24} \right] \\
& + \frac{1}{EI} \sum_{i=1}^2 \frac{(q_{Ri}-q_{Li})(L-d_i)^5}{120(d_i-c_i)}
\end{aligned} \quad (63)$$

where B is the reaction force at the fixed end. The Young's modulus is $E = 200 \times 10^9 \text{ Pa}$,

and the moment of inertia is $I = \frac{wh^3}{12}$. Based on the given limit-state function in Eq. (62),

twelve training points at failure states are generated by simulation and are transformed into the U-space as listed in Table 5. Since S_a and τ_a do not affect the third failure

mode, their components U_7 and U_8 are absent in the training points. As discussed previously, p_{f3} is estimated by a statistics-based reliability method using the data set from reliability testing and is assumed equal to the probability of failure $p_{f3} = 2.864 \times 10^{-4}$ produced by FORM with the true-limit state function in Eq. (62).

Table 5 Training points for FM3

No.	u					
	$U_1(M_1)$	$U_2(M_2)$	$U_3(a_1)$	$U_4(a_2)$	$U_5(F_1)$	$U_6(b_1)$
1	2.8351	2.0504	-1.6190	-1.5710	2.0410	0.8219
2	1.7433	2.2424	-0.1380	0.9161	2.5797	2.1406
3	1.0681	2.6931	-1.2685	-0.5628	2.0397	-0.1730
4	4.0026	2.6572	-1.4512	-0.4765	2.0030	-0.4871
5	2.2738	3.5800	0.4564	0.7455	-0.2342	-0.7254
6	0.2692	2.6336	1.3638	0.2184	2.8383	0.4362
7	1.0906	3.1686	0.4705	-0.3467	0.9793	1.6114
8	1.0306	3.3218	-0.1654	-1.9311	0.9750	1.0332
9	1.4163	3.3888	0.7300	-0.4728	1.1202	0.9889
10	1.0380	3.0489	-0.2377	-0.0370	1.3500	0.6203
11	1.0432	2.6388	-1.6206	0.3320	2.6083	-0.3964
12	0.6974	3.2863	1.4655	2.2559	1.4333	-0.5095

Assume the linear model for FM3 is given by

$$Z_3^{\text{II}}(\mathbf{U}) = \beta_3^{\text{II}} + \alpha_3^{\text{II}} \mathbf{U}^T \quad (64)$$

where $\beta_3^{\text{II}} = -\Phi^{-1}(p_{f3}) = 3.4442$. α_3^{II} is obtained from the following optimization model

$$\begin{cases} \max_{\boldsymbol{\lambda}} \sum_{i=1}^{12} \lambda_i - \frac{1}{2} \sum_{i,j=1}^{12} \lambda_i \lambda_j \mathbf{u}_i \mathbf{u}_j^T \\ \text{s.t. } \lambda_i \geq 0, \quad \forall i = 1, 2, \dots, 12 \end{cases} \quad (65)$$

in which \mathbf{u}_i represents the training points given in Table 5. Solving the above the model, we obtain the Lagrange multipliers $\boldsymbol{\lambda} = (0, 0, 0.0345, 0, 0.0047, 0.0037, 0.0203, 0, 0, 4.25 \times 10^{-4}, 0, 0.0108)$; therefore, six support vectors $\mathbf{u}_3, \mathbf{u}_5, \mathbf{u}_6, \mathbf{u}_7, \mathbf{u}_{10}$, and \mathbf{u}_{12} are determined by the nonzero components $\lambda_3, \lambda_5, \lambda_6, \lambda_7, \lambda_{10}$ and λ_{12} in $\boldsymbol{\lambda}$. Then using

$\boldsymbol{\lambda}, \mathbf{u}_1, \mathbf{u}_2, \dots,$ and \mathbf{u}_{12} in $\boldsymbol{\omega}_3 = -\sum_{i=1}^{12} \lambda_i \mathbf{u}_i$, we have $\boldsymbol{\omega}_3 = (-0.0787, -0.2207, 0.0113, -0.0023, -0.1157, -0.0197)$, which produces the unit vector $\boldsymbol{\alpha}_3^{\text{II}} = \frac{\boldsymbol{\omega}_3}{\|\boldsymbol{\omega}_3\|} = (-0.3001, -0.8414, 0.0430, -0.0087, -0.4409, -0.0750)$.

Thus, the linear model in Eq. (64) is determined and is given by

$$Z_3^{\text{II}}(\mathbf{U}) = 3.4442 - 0.3001U_1 - 0.8414U_2 + 0.0113U_3 - 0.0023U_4 - 0.1157U_5 - 0.0197U_6 \quad (66)$$

Since the first two failure modes are Type I components, FORM could be directly used with the following linear models:

$$Z_i^{\text{I}}(\mathbf{U}) = \beta_i^{\text{I}} + \boldsymbol{\alpha}_i^{\text{I}} \mathbf{U}^T \quad (i = 1, 2) \quad (67)$$

in which $\beta_1^{\text{I}} = 3.4989$, $\beta_2^{\text{I}} = 3.2470$, $\boldsymbol{\alpha}_1^{\text{I}} = (-0.181, -0.181, 0, 0, -0.826, -0.046)$, and

$\boldsymbol{\alpha}_2^{\text{I}} = (0, 0, 0, 0, -0.92, 0)$.

Thus, vector $[Z_1^{\text{I}}(\mathbf{U}), Z_2^{\text{I}}(\mathbf{U}), Z_3^{\text{II}}(\mathbf{U})]$ follows a multivariate normal distribution with the joint PDF given by

$$\phi_{\mathbf{u}}(\mathbf{u}) = \frac{1}{\sqrt{(2\pi)^3 |\boldsymbol{\Sigma}|}} \exp\left(-\frac{1}{2}(\mathbf{u}-\boldsymbol{\mu})^T \boldsymbol{\Sigma}^{-1}(\mathbf{u}-\boldsymbol{\mu})\right) \quad (68)$$

where the mean $\boldsymbol{\mu}$ and covariance matrix $\boldsymbol{\Sigma}$ are given by

$$\boldsymbol{\mu} = (\beta_1^I, \beta_2^I, \beta_3^{II}) = (3.4989, 3.2470, 3.4442)$$

$$\text{and } \boldsymbol{\Sigma} = \begin{bmatrix} 1 & \rho_{12} & \rho_{13} \\ \rho_{12} & 1 & \rho_{23} \\ \rho_{13} & \rho_{23} & 1 \end{bmatrix} = \begin{bmatrix} 1 & 0.7608 & 0.5744 \\ 0.7608 & 1 & 0.4062 \\ 0.5744 & 0.4062 & 1 \end{bmatrix}, \text{ where } \rho_{12}, \rho_{13} \text{ and } \rho_{23} \text{ are the}$$

correlation coefficients between $Z_1^I(\mathbf{U})$ and $Z_2^I(\mathbf{U})$, $Z_1^I(\mathbf{U})$ and $Z_3^{II}(\mathbf{U})$, and $Z_2^I(\mathbf{U})$ and $Z_3^{II}(\mathbf{U})$, respectively.

The system reliability is then calculated by

$$R_s = \Pr\left(-Z_1^I(\mathbf{U}) < 0 \cap -Z_2^I(\mathbf{U}) < 0 \cap -Z_3^{II}(\mathbf{U}) < 0\right) = \int_{\Omega} \phi_{\mathbf{u}}(\mathbf{u}) d\mathbf{u} \quad (69)$$

where Ω is the system safe region defined by

$$\Omega = \left\{ \mathbf{U} \mid -Z_1^I(\mathbf{U}) < 0, -Z_2^I(\mathbf{U}) < 0, -Z_3^{II}(\mathbf{U}) < 0 \right\} \quad (70)$$

Then Eq. (72) yields $p_{fs} = 1 - R_s = 1.0198 \times 10^{-3}$.

Table 6 Results from different methods

	Proposed Method	Independent Assumption Method	True Value
p_{fs}	1.0198×10^{-3}	1.1028×10^{-3}	1.0155×10^{-3}
Error (%)	0.42	8.59	—

For validation, we use FORM and all the given limit-state functions $g_1^I(\mathbf{X})$, $g_2^I(\mathbf{X})$, and $g_3^{II}(\mathbf{X})$ to solve for the true system reliability. Likewise, we also use the independence assumption method. The results are shown in Table 6. The proposed method outperforms the independence assumption method with much higher accuracy.

6. CONCLUSIONS

Motivated by the need for creating component models from one-class failure data in system reliability prediction, this study develops a new one-class SVM method for data set that is on one side of a hyperplane, which is tangent to a hypersphere with a known radius. Different from traditional SVM methods, the new method creates a linear model using both the given data set and the radius; in other words, only the direction of the hyperplane is determined.

The advantages of the proposed method for system reliability prediction are multifold. At first, it reveals the relationship between component states (safe or failed) with factors that affect the state, such as component dimensions, loading, and environment. Second, the method makes it possible to account for the dependence between component states through the created models. Third, the method allows for a complete probability density function of all the component states. Fourth, the method provides a feasible way to integrate physics- and statistics-based reliability methods. As a result, an accurate system reliability prediction can be produced.

There are several assumptions for the application of the proposed method, such as the distributions of basic random variables are known, the reliability resulting from the

first order reliability method is accurate, and no stochastic processes are involved. In our future study, we will extend the method to time-dependent problems where the data set varies with respect to time.

ACKNOWLEDGEMENTS

This material is based upon work supported by the National Science Foundation under Grant No. CMMI 1562593.

REFERENCES

- [1] Vapnik, V., 2013, *The nature of statistical learning theory*, Springer science & business media.
- [2] Boser, B. E., Guyon, I. M., and Vapnik, V. N., "A training algorithm for optimal margin classifiers," *Proc. Proceedings of the fifth annual workshop on Computational learning theory*, ACM, pp. 144-152.
- [3] Vapnik, V. N., and Vapnik, V., 1998, *Statistical learning theory*, Wiley New York.
- [4] Tian, Y., Shi, Y., and Liu, X., 2012, "Recent advances on support vector machines research," *Technological and Economic Development of Economy*, 18(1), pp. 5-33.
- [5] Peng, X., 2011, "TPMSVM: a novel twin parametric-margin support vector machine for pattern recognition," *Pattern Recognition*, 44(10), pp. 2678-2692.
- [6] Truong, T. X., and Kim, J.-M., 2012, "Fire flame detection in video sequences using multi-stage pattern recognition techniques," *Engineering Applications of Artificial Intelligence*, 25(7), pp. 1365-1372.
- [7] Frias-Martinez, E., Sanchez, A., and Velez, J., 2006, "Support vector machines versus multi-layer perceptrons for efficient off-line signature recognition," *Engineering Applications of Artificial Intelligence*, 19(6), pp. 693-704.
- [8] Cortez, P., 2010, "Data mining with neural networks and support vector machines using the R/rminer tool," *Advances in data mining. Applications and theoretical aspects*, pp. 572-583.

- [9] Chen, K.-Y., Chen, L.-S., Chen, M.-C., and Lee, C.-L., 2011, "Using SVM based method for equipment fault detection in a thermal power plant," *Computers in industry*, 62(1), pp. 42-50.
- [10] Mahadevan, S., and Shah, S. L., 2009, "Fault detection and diagnosis in process data using one-class support vector machines," *Journal of process control*, 19(10), pp. 1627-1639.
- [11] Gryllias, K. C., and Antoniadis, I. A., 2012, "A Support Vector Machine approach based on physical model training for rolling element bearing fault detection in industrial environments," *Engineering Applications of Artificial Intelligence*, 25(2), pp. 326-344.
- [12] Hanna, S., 2007, "Inductive machine learning of optimal modular structures: Estimating solutions using support vector machines," *AI EDAM*, 21(4), pp. 351-366.
- [13] Li, H.-s., Lü, Z.-z., and Yue, Z.-f., 2006, "Support vector machine for structural reliability analysis," *Applied Mathematics and Mechanics*, 27(10), pp. 1295-1303.
- [14] Das Chagas Moura, M., Zio, E., Lins, I. D., and Droguett, E., 2011, "Failure and reliability prediction by support vector machines regression of time series data," *Reliability Engineering & System Safety*, 96(11), pp. 1527-1534.
- [15] Wang, H.-Q., Cai, Y.-N., Fu, G.-Y., Wu, M., and Wei, Z.-H., 2018, "Data-driven fault prediction and anomaly measurement for complex systems using support vector probability density estimation," *Engineering Applications of Artificial Intelligence*, 67, pp. 1-13.
- [16] Akbani, R., Kwek, S., and Japkowicz, N., 2004, "Applying support vector machines to imbalanced datasets," *Machine learning: ECML 2004*, pp. 39-50.
- [17] Ma, J., and Perkins, S., "Time-series novelty detection using one-class support vector machines," *Proc. Neural Networks, 2003. Proceedings of the International Joint Conference on, IEEE*, pp. 1741-1745.
- [18] Manevitz, L. M., and Yousef, M., 2001, "One-class SVMs for document classification," *Journal of Machine Learning Research*, 2(Dec), pp. 139-154.
- [19] Dreiseitl, S., Osl, M., Scheibböck, C., and Binder, M., "Outlier detection with one-class SVMs: An application to melanoma prognosis," *Proc. AMIA Annual Symposium Proceedings, American Medical Informatics Association*, p. 172.
- [20] Schölkopf, B., 2001, "Statistical learning and kernel methods," *Data Fusion and Perception*, Springer, pp. 3-24.
- [21] Abe, S., 2005, *Support vector machines for pattern classification*, Springer.

- [22] Schölkopf, B., Platt, J. C., Shawe-Taylor, J., Smola, A. J., and Williamson, R. C., 2001, "Estimating the support of a high-dimensional distribution," *Neural computation*, 13(7), pp. 1443-1471.
- [23] Cruse, T. A., 1997, *Reliability-based mechanical design*, CRC Press.
- [24] Hu, Z., and Du, X., "A physics-based reliability method for components adopted in new series systems," *Proc. 2016 Annual Reliability and Maintainability Symposium (RAMS)*, IEEE, pp. 1-7.
- [25] Mahadevan, S., 1997, "Physics-based reliability models," *Mechanical Engineering-New York and Basel-Marcel Dekker*, pp. 197-232.
- [26] Hu, Z., Nannapaneni, S., and Mahadevan, S., 2017, "Efficient Kriging surrogate modeling approach for system reliability analysis," *AI EDAM*, 31(2), pp. 143-160.
- [27] Meeker, W. Q., and Escobar, L. A., 2014, *Statistical methods for reliability data*, John Wiley & Sons.
- [28] Lawless, J., 1983, "Statistical methods in reliability," *Technometrics*, 25(4), pp. 305-316.
- [29] Hoyland, A., and Rausand, M., 2004, *System reliability theory: models, statistical methods, and applications*, NJ: Wiley-Interscience.
- [30] Chiralaksanakul, A., and Mahadevan, S., 2005, "First-order approximation methods in reliability-based design optimization," *Journal of Mechanical Design*, 127(5), pp. 851-857.
- [31] Zhao, Y. G., and Ono, T., 1999, "A general procedure for first/second-order reliability method (FORM/SORM)," *Structural Safety*, 21(2), pp. 95-112.
- [32] Du, X., and Sudjianto, A., 2004, "First order saddlepoint approximation for reliability analysis," *AIAA journal*, 42(6), pp. 1199-1207.
- [33] Green, R. C., Wang, L., Alam, M., and Singh, C., 2013, "Intelligent state space pruning for Monte Carlo simulation with applications in composite power system reliability," *Engineering applications of artificial intelligence*, 26(7), pp. 1707-1724.
- [34] Rosenblatt, M., 1952, "Remarks on a multivariate transformation," *The annals of mathematical statistics*, 23(3), pp. 470-472.
- [35] Hu, Z., and Du, X., 2017, "System reliability prediction with shared load and unknown component design details," *AI EDAM*, 31(3), pp. 223-234.
- [36] Click, R. L., and Duening, T. N., 2004, *Business process outsourcing: the competitive advantage*, John Wiley & Sons.

- [37] Cheng, Y., and Du, X., 2016, "System Reliability Analysis With Dependent Component Failures During Early Design Stage—A Feasibility Study," *Journal of Mechanical Design*, 138(5), p. 051405.
- [38] Hu, Z., and Du, X., 2017, "System reliability analysis with in-house and outsourced components," 2017 2nd International Conference on System Reliability and Safety, IEEE, Milan, Italy.
- [39] Yong Cang, Z., 1993, "High-order reliability bounds for series systems and application to structural systems," *Computers and Structures*, 46(2), pp. 381-386.

IV. A PARTIAL SAFETY FACTOR METHOD FOR SYSTEM RELIABILITY PREDICTION WITH OUTSOURCED COMPONENTS

Zhengwei Hu and Xiaoping Du

Department of Mechanical and Aerospace Engineering

Missouri University of Science and Technology

ABSTRACT

System reliability is usually predicted with the assumption that all component states are independent. This assumption is particularly useful for systems with outsourced components. The assumption, however, may produce large errors in the system reliability prediction since many component states are strongly dependent. The purpose of this study is to develop an accurate system reliability method that can produce complete joint probability density function (PDF) of all the component states, thereby leading to accurate system reliability predictions. The proposed method works for systems whose failures are caused by excessive loading. In addition to the component reliability, system designers also ask for partial safety factors for shared loadings from component suppliers. The information is then sufficient for building a system-level joint PDF. Algorithms are designed for a component supplier to generate partial safety factors, which enables accurate system reliability predictions without requiring proprietary information from component suppliers.

1. INTRODUCTION

System reliability is the ability that a system performs its intended function. It is often measured by the probability that the system can work properly without any failure. Since a system is composed of multiple components, its reliability depends on the reliability of each component. Accurate system reliability prediction requires the joint probability density function (PDF) of all the component states. It is difficult or even impossible to obtain the joint PDF. For this reason, the system reliability is commonly approximated with the assumption that all component states are independent. For a series system consisting of n components, the assumption gives

$$R_s = \prod_{i=1}^n R_i \quad (1)$$

where R_s is the system reliability, and R_i is the reliability of component i .

The independence assumption is particularly useful for systems whose components are outsourced. Outsourcing is a common practice as many industrial firms, such as automakers, function as system integrators, relying on various outside component suppliers. For example, numerous parts of vehicles are designed and manufactured outside except for engines and powertrains that the automaker wants to keep in-house. This practice has resulted in huge cost savings in developing new products [1, 2]. During the system design stage, system designers can easily estimate the system reliability using Eq. (1) after they obtain component reliability R_i ($i=1,2,\dots,n$) from component suppliers. The independence assumption does not require system designers to know component design details [3, 4], which in most cases are proprietary to component suppliers. When the component reliability is predicted with physics-based reliability

methods, the component design details include component limit-state functions that specify the component states (safe or failed) [5].

The major drawback of the independence assumption method is the poor accuracy when component states are strongly dependent. This is often the case for mechanical systems. Components in a mechanical system may share the same random operation conditions, such as excessive stresses, making component failures highly dependent. Eq. (1) is actually the worst-case system reliability when component states are positively dependent. (This is the case for most mechanical applications.) The best-case system reliability is equal to the worst component reliability $\min\{R_i\}_{i=1,2,\dots,n}$ under the assumption that all component failures are completely dependent. Then the error of the system reliability prediction without knowing the system joint PDF is given by [6]

$$\prod_{i=1}^n R_i \leq R_s \leq \min\{R_i\}, \quad (i = 1, 2, \dots, n) \quad (2)$$

The above reliability bound may be too wide to make any useful decisions. To narrow this bound, Ditlevsen [7] proposed a method to obtain series system reliability bounds with the involvement of both unicomponent probabilities and bicomponent probabilities. Zhang [8] generalized this method by introducing joint probabilities of larger sets of components. Both methods require complete limit-state functions of all the components, making the methods not applicable for systems with outsourced components.

To address this issue, Hu and Du [9, 10] proposed a physics-based reliability method for component adopted in new series systems. The method reconstructs component limit-state functions at the system-level using limited reliability information. This method is able to build the joint PDF of the component states, thereby estimating

system reliability with high accuracy. It requires, however, reliability functions with respect to the system load, increasing the burden of component reliability analysis on the component supplier side. To fix this problem, a new method [11] was developed to rebuild an equivalent component limit-state function under new conditions without knowing the relationship between the reliability and load. But the method may be inefficient for systems with more than two shared loads among components.

Many other reliability methods can also be used for the system reliability prediction. Yu and Wang [12] proposed a reliability assessment approach by combining the extreme value moment method and the improved maximum entropy method for systems with multiple failure modes. Recently, they also developed a novel time-variant reliability analysis method based on failure process decomposition for dynamic systems [13] and a kernel density function based on the uncertainty quantification method for estimating the reliability of a robotic device [14]. Some statistical-based methods are also widely used for system reliability evaluation, including Linear Regression (LR) [15], Artificial Neural Network (ANN) [16], and Support Vector Machines (SVM) [17, 18]. Even with no component design details, these methods could reconstruct a precise decision boundary (response surface) of the component using training data. To evaluate the system reliability, however, they still require additional information from component suppliers.

The objective of this work is to develop a new system reliability method linking both component-level and system-level analyses. At the component level, the proposed method enables component suppliers to provide enough information to system designers without revealing their component design details. At the system level, the proposed

method helps system designers produce a complete joint PDF of all the component states, thereby leading to accurate system reliability prediction. Specifically, the major approach we use in the proposed method is the employment of partial safety factors (PSFs), which are specified by component suppliers for shared loads from the system with physics-based reliability. Then system designers use the PSFs from component suppliers to rebuild equivalent component limit-state functions [19, 20], which in turn produce the joint PDF that is necessary for the system reliability prediction.

The rest of this paper is organized as follows. Basic methodologies used in this work are reviewed in Section 2. The overview of the proposed methods is given in Section 3. The system-level analysis is discussed in Section 4 followed by component-level analysis in Section 5. In Section 6 the complete procedure of the proposed method is described. Examples are discussed in Section 7. Conclusions are given in Section 8.

2. METHODOLOGY REVIEW

The proposed method can employ any physics-based reliability methods, including First-Order Reliability Method (FORM), Second-Order Reliability Method (SORM), and Monte Carlo Simulation (MCS). The methods are briefly reviewed in Section 2.1. We also review the concept of PSF in Section 2.2.

2.1 FIRST ORDER RELIABILITY METHOD (FORM)

FORM linearizes a limit-state function $g(\mathbf{X})$ at the Most Probable Point (MPP) using the first order Taylor expansion, and then the probability of failure p_f is obtained.

Step 1 is to transform random variables into standard normal variables. Assume that all random variables in $\mathbf{X} = (X_1, X_2, \dots, X_n)$ are independent. The random variables in \mathbf{X} are transformed into standard normal random variables $\mathbf{U} = (U_1, U_2, \dots, U_n)$. The transformation is given by [21]

$$F_i(X_i) = \Phi(U_i) \quad (i = 1, 2, \dots, n) \quad (3)$$

where $F_i(\cdot)$ and $\Phi(\cdot)$ are the cumulative distribution functions (CDF) of X_i and U_i , respectively. Then

$$X_i = F_i^{-1}(\Phi(U_i)) = T(U_i) \quad (i = 1, 2, \dots, n) \quad (4)$$

in which $T(\cdot)$ denotes the transformation operation.

Step 2 is to search for the MPP. p_f is computed by

$$p_f = \Pr\{g(T(\mathbf{U})) < 0\} = \int_{g(T(\mathbf{U})) < 0} \phi_{\mathbf{U}}(\mathbf{u}) d\mathbf{u} \quad (5)$$

in which $\phi_{\mathbf{U}}(\mathbf{u})$ is the joint PDF of \mathbf{U} . FORM linearizes $g(T(\mathbf{U}))$ and minimizes linearization error by using an expansion point \mathbf{u}^* obtained from

$$\begin{cases} \min_{\mathbf{U}} \sqrt{\mathbf{U}\mathbf{U}^T} \\ \text{s.t. } g(T(\mathbf{U})) = 0 \end{cases} \quad (6)$$

\mathbf{u}^* is called the Most Probable Point (MPP), and its magnitude is called the reliability index and is given by

$$\beta = \sqrt{\mathbf{u}^* (\mathbf{u}^*)^T} \quad (7)$$

With the first Taylor expansion series, $g(T(\mathbf{U}))$ is approximated at \mathbf{u}^* as

$$g(T(\mathbf{U})) \approx g(T(\mathbf{u}^*)) + \nabla g(\mathbf{u}^*)(\mathbf{U} - \mathbf{u}^*)^T = \nabla g(\mathbf{u}^*)(\mathbf{U} - \mathbf{u}^*)^T \quad (8)$$

where $\nabla g(\mathbf{u}^*)$ is the gradient of $g(T(\mathbf{U}))$ at \mathbf{u}^* and is given by

$$\nabla g(\mathbf{u}^*) = \left(\frac{\partial g(T(\mathbf{U}))}{\partial U_1}, \frac{\partial g(T(\mathbf{U}))}{\partial U_2}, \dots, \frac{\partial g(T(\mathbf{U}))}{\partial U_n} \right) \Bigg|_{\mathbf{u}^*} \quad (9)$$

Set a unit vector $\boldsymbol{\alpha}$ as

$$\boldsymbol{\alpha} = \frac{\nabla g(\mathbf{u}^*)}{\|\nabla g(\mathbf{u}^*)\|} \quad (10)$$

Then \mathbf{u}^* is represented by

$$\mathbf{u}^* = -\beta \boldsymbol{\alpha} \quad (11)$$

Substituting Eqs. (10) and (11) into Eq. (8) and multiplying both sides of Eq. (8)

by $\frac{1}{\|\nabla g(\mathbf{u}^*)\|}$ yields a new limit-state function

$$G(\mathbf{U}) = \frac{g(T(\mathbf{U}))}{\|\nabla g(\mathbf{u}^*)\|} \approx \beta + \boldsymbol{\alpha} \mathbf{U} \quad (12)$$

The last step is to compute p_f , which is calculated by

$$p_f \approx \Pr \{G(\mathbf{U}) < 0\} = \Phi(-\beta) \quad (13)$$

Since FORM is based on the first order Taylor expansion, it is accurate when the limit-state function is not highly nonlinear. Otherwise, SORM is a better choice.

2.2 SECOND ORDER RELIABILITY METHOD (SORM)

SORM uses the second order Taylor expansion to approximate $g(\mathbf{X})$ at the MPP, which is given by

$$\begin{aligned} g(T(\mathbf{U})) &\approx g(\mathbf{u}^*) + \nabla g(\mathbf{u}^*)(\mathbf{U} - \mathbf{u}^*) \\ &\quad + \frac{1}{2}(\mathbf{U} - \mathbf{u}^*) \nabla^2 g(\mathbf{u}^*)(\mathbf{U} - \mathbf{u}^*) \end{aligned} \quad (14)$$

where $\nabla g(\mathbf{u}^*)$ is given in Eq. (9) and $\nabla^2 g(\mathbf{u}^*)$ is the Hessian matrix. Since there is no closed-form expression for p_f [22], an orthogonal transformation $\mathbf{Y} = \mathbf{H}\mathbf{U}$ is conducted. This transformation rotates the U-space into a new set of mutually independent standard normal variables \mathbf{Y} with Y_n coincident with the MPP vector. Matrix \mathbf{H} is an orthogonal matrix and is obtained by a Gram-Schmidt [23] orthogonalization. Then the approximated limit-state function is rewritten as

$$G(\mathbf{Y}) \approx -Y_n + \beta + \frac{1}{2}(\mathbf{Y} - \mathbf{y}^*)\mathbf{M}(\mathbf{Y} - \mathbf{y}^*)^T \quad (15)$$

where $\mathbf{y}^* = (0, 0, \dots, \beta)^T$ is the Y-space MPP corresponding to the \mathbf{u}^* , and \mathbf{M} is the transformed Hessian matrix and is given by

$$\mathbf{M} = \mathbf{H} \frac{\nabla^2 g(\mathbf{u}^*)}{\|\nabla g(\mathbf{u}^*)\|} \mathbf{H}^T \quad (16)$$

After a series of orthogonal transformations, with the first $n-1$ variables being $\bar{\mathbf{Y}} = (y_1, y_2, \dots, y_{n-1})^T$, the first $(n-1) \times (n-1)$ order matrix of \mathbf{M} becomes a diagonal matrix, and Eq. (15) becomes

$$Y_n = \beta + \frac{1}{2} \sum_{i=1}^{n-1} k_i y_i'^2 \quad (17)$$

where k_i represents the curvature of the response surface at the MPP, and finding k_i can be treated as an eigenvalue problem.

The probability of failure is then estimated using Breitung's formulation, which is given by

$$p_{f, \text{Breitung}} = \Phi(-\beta) \prod_{i=1}^{n-1} (1 + k_i \beta)^{-1/2} \quad (18)$$

A more accurate expression is derived from Tvedt's formulations which is given by [23]

$$p_{f, \text{Breitung}} = A_1 + A_2 + A_3 \quad (19)$$

in which

$$\left\{ \begin{array}{l} A_1 = \Phi(-\beta) \prod_{i=1}^{n-1} (1 + k_i \beta)^{-1/2} \\ A_2 = [\beta \Phi(-\beta) - \Phi(\beta)] \\ \quad \times \left[\prod_{i=1}^{n-1} (1 + k_i \beta)^{-1/2} - \prod_{i=1}^{n-1} (1 + k_i (\beta + 1))^{-1/2} \right] \\ A_3 = (\beta + 1) [\beta \Phi(-\beta) - \Phi(\beta)] \\ \quad \times \left[\prod_{i=1}^{n-1} (1 + k_i \beta)^{-1/2} - \operatorname{Re} \left[\prod_{i=1}^{n-1} (1 + k_i (\beta + 1))^{-1/2} \right] \right] \end{array} \right. \quad (20)$$

where $\operatorname{Re}(\cdot)$ denotes the real part of an imaginary number.

2.3 MONTE CARLO SIMULATION (MCS)

MCS is a sampling method. The procedure of MCS is below.

- 1) Generate N samples of \mathbf{X} .
- 2) Calculate the response $g(\mathbf{X})$ at samples of \mathbf{X} , and then N samples of $g(\mathbf{X})$ are available.
- 3) Count the number of samples of $g(\mathbf{X})$ in the failure region ($g(\mathbf{X}) < 0$). Denote the number of failures by N_f . The probability of failure is then given by

$$p_f = \frac{N_f}{N} \quad (21)$$

2.4 PARTIAL SAFETY FACTOR (PSF)

PSFs are commonly used in modern structural design (limit state design), which are usually applied to loads and material properties for a safe design. The PSF for a load, which is generally greater than unity, sets the design value of the load equal to the product of the PSF and the service load (or desired load). The PSF for a material strength is usually less than unity. Multiplying the PSF by the material strength determines the permissible stress (strength) of the material. For example, a load acting on a cantilever beam is multiplied by a PSF > 1 to account for the variation of the load due to a sudden increase. Similarly, a PSF < 1 is applied to the characteristic stress of the material to ensure that sufficient strength is provided.

In general, for a component with limit-state function $g(\mathbf{X})$, the basic random variables in \mathbf{X} include applied loads $\mathbf{L} = (L_1, L_2, \dots, L_p)$ and component strength S . With PSFs, the safe state of the component is specified by [24]

$$g(\mathbf{X}) = g(\lambda\mu_S, \gamma_i\mu_{L_i}) > 0 \quad (22)$$

where $\lambda < 1$ is the PSF (reduction factor of strength) for the strength, and γ_i is the PSF (partial load amplification factor) for load L_i ($i = 1, 2, \dots, p$); μ_S is the mean of S , and μ_{L_i} is the mean of L_i .

With distributions of S and L_i available, the PSFs λ and γ_i could be easily computed. Assume that component suppliers use FORM for the reliability analysis, which produces the MPP \mathbf{u}^* and the reliability index β . The partial safety factors λ and γ_i can be obtained by

$$\lambda = \frac{S^*}{\mu_S} = \frac{F_S^{-1}(\Phi(-\beta\alpha_S))}{\mu_S} \quad (23)$$

$$\gamma_i = \frac{L_i^*}{\mu_{L_i}} = \frac{F_{L_i}^{-1}(\Phi(-\beta\alpha_{L_i}))}{\mu_{L_i}} \quad (24)$$

in which S^* and L_i^* are components of the MPP in in the X-space for S and L_i , respectively; α_S and α_{L_i} are the directional cosine of S and L_i in the U-space, respectively.

If $g(\mathbf{X})$ is not available to component suppliers, physics-based methods cannot be directly applied for the reliability analysis. In these cases, statistics-based methods, such as Support Vector Machine [18], are good choices to approximate the component limit-state function with limited observations; then λ and γ_i will be available.

3. SYSTEM RELIABILITY PREDICTION WITH PSFS

The proposed system reliability method works for the following systems with outsourced components.

- 1) System and component failures are caused by excessive stresses.
- 2) Components share a number of loads, which are the only common basic variables shared by component limit-state functions.
- 3) A component may have multiple failure modes.
- 4) System designer knows the distributions of loads distributed to components.
- 5) System designers do not know component limit-state functions.
- 6) System designers know component reliability provided by component suppliers.

- 7) Component suppliers also provide PSFs they used in their component design to system designers.

The basic strategy of the PSF method is that system designers construct equivalent component limit-state functions and convert them into a multivariate normal distribution, whose distribution parameters are estimated through the component reliability and component PSFs provided by component suppliers. Once the joint normal PDF is available, the system reliability can be easily estimated.

It is therefore important for component suppliers to produce component reliabilities and PSFs. For the former, any physics-and statistics-based methods, such as FORM, SORM, MCS, SVM, and experiments can be used. For the latter, the proposed method relies on the concept of equivalent linear safety margin [19, 25] to determine PSFs for components with multiple failure modes.

The PSF method therefore involves both system- and component-level reliability analyses. Both of them are discussed in Sections 4 and 5.

4. SYSTEM-LEVEL ANALYSIS

At the system analysis level, the task of system designers is to accurately predict system reliability with only the component reliability and corresponding PSFs.

Assume that the system consists of m components and is subjected to multiple loads $\mathbf{L} = (L_1, L_2, \dots, L_p)$. Component probabilities of failure p_{fi} and PSFs $\gamma_i = (\gamma_{i,1}, \gamma_{i,2}, \dots, \gamma_{i,p})$ of $\mathbf{L} = (L_1, L_2, \dots, L_p)$, $i = 1, 2, \dots, m$, are provided by component suppliers.

For component i , system designers construct an equivalent limit-state function no matter how many failure modes the component may have and what reliability method that the component supplier has used. The equivalent limit-state function contains only shared load $\mathbf{L} = (L_1, L_2, \dots, L_p)$ in a linear form

$$G_i(\mathbf{U}) \approx \beta_i + \alpha_{i,L_1} U_{L_1} + \dots + \alpha_{i,L_p} U_{L_p} \quad (25)$$

where β_i is the reliability index given by

$$\beta_i = \Phi(-p_{fi}) \quad (26)$$

$\mathbf{U}_L = (U_{L_1}, U_{L_2}, \dots, U_{L_p})$ is the transformed vector of $\mathbf{L} = (L_1, L_2, \dots, L_p)$, and $\alpha_{i,L_j}, j = 1, 2, \dots, p$, are coefficients.

System designers can find α_{i,L_j} using PSFs $\gamma_{i,j}$. The equation is given by

$$\alpha_{i,L_j} = -\beta_i^{-1} \Phi^{-1} \left(F_{L_j}(\gamma_{i,j} \mu_{L_j}) \right) \quad (27)$$

Eq. (27) can be easily derived if FORM is used by the component supplier. Since $L_{i,j}^* = \gamma_{i,j} \mu_{L_j}$ is the MPP component of L_j in the X-space, we have

$$F_{L_j}(L_{i,j}^*) = \Phi(u_{L_j}^*) \quad (28)$$

in which $F_{L_j}(\cdot)$ is the CDF of L_j , and $u_{L_j}^*$ is the MPP component of L_j in the U-space.

According to Eq. (11) and $u_{L_{i,j}}^* = -\alpha_{i,L_j} \beta_i$, Eq. (27) is rewritten as

$$F_{L_j}(L_j^*) = \Phi(-\alpha_{i,L_j} \beta_i) \quad (29)$$

This leads to Eq. (27).

Note that using FORM is not a prerequisite for the PSF method. As will be discussed in Section 5, other reliability methods can also be used.

Since the components of \mathbf{U} follow standard normal distributions, the limit-state function $G_i(\mathbf{U})$ with respect to \mathbf{U} also follows a normal distribution with the mean value of β_i and standard deviation of 1. Thus, the joint PDF of all the component states in Eq. (25) follows a multivariate normal distribution with the joint PDF $\phi_G(\cdot)$ determined by the mean vector $\boldsymbol{\mu}$ and covariance matrix $\boldsymbol{\Sigma}$, which are respectively given by

$$\boldsymbol{\mu} = (-\beta_1, -\beta_2, \dots, -\beta_m) \quad (30)$$

$$\boldsymbol{\Sigma} = \begin{bmatrix} 1 & \rho_{12} & \cdots & \rho_{1m} \\ \rho_{21} & 1 & & \rho_{2m} \\ \vdots & \vdots & \ddots & \vdots \\ \rho_{m1} & \rho_{m2} & \cdots & 1 \end{bmatrix}_{m \times m} \quad (31)$$

in which ρ_{ij} is calculated by

$$\rho_{ij} = \sum_{k=1}^p \alpha_{i,Lp} \alpha_{j,Lp} \quad (32)$$

With the obtained $\boldsymbol{\mu}$ and $\boldsymbol{\Sigma}$, $\phi_G(\cdot)$ is given by

$$\phi_G(\mathbf{v}) = \frac{1}{\sqrt{(2\pi)^n |\boldsymbol{\Sigma}|}} \exp\left(-\frac{1}{2}(\mathbf{v} - \boldsymbol{\mu})^T \boldsymbol{\Sigma}^{-1}(\mathbf{v} - \boldsymbol{\mu})\right) \quad (33)$$

The system reliability is calculated by

$$R_s = \int_{\Omega} \phi_G(\mathbf{v}) d\mathbf{v} = \Phi_k(-\boldsymbol{\mu}; \boldsymbol{\Sigma}) \quad (34)$$

where $\Phi(-\boldsymbol{\mu}; \boldsymbol{\Sigma})$ is the CDF of $\phi_G(\cdot)$, and Ω is the system safe region defined by

$$\Omega = \{\mathbf{U} \mid -G_i(\mathbf{U}) < 0 \ (i = 1, 2, \dots, m)\} \quad (35)$$

The system probability of failure is then given by

$$p_{fs} = 1 - R_s \quad (36)$$

5. COMPONENT-LEVEL ANALYSIS

As discussed above, the task of a component supplier is to provide the component reliability and PSFs of the shared loads to system designers. We now discuss the proposed method for doing so.

A component may fail due to multiple failure modes. For each failure mode the component supplier could use various methods to obtain the component reliability.

Given component i with q failure modes and the limit-state functions $G_{i,k}(\mathbf{U}_i) = g_{i,k}(\mathbf{U}_{i-L}, \mathbf{U}_L)$ ($k=1, 2, \dots, q$), where \mathbf{U}_i is the vector of the basic variables, \mathbf{U}_L is the vector of the shared loads, and \mathbf{U}_{i-L} is the vector of \mathbf{U}_i without \mathbf{U}_L in the U-space. We at first discuss the case where FORM is used. The approximated limit-state functions by FORM are given by

$$G_{i,k}(\mathbf{U}) \approx \beta'_{i,k} + \alpha'_{i,k1} U_{i-L1} + \dots + \alpha'_{i,kL_1} U_{iL_1} + \dots + \alpha'_{i,kL_p} U_{iL_p}, \quad k=1, 2, \dots, q \quad (37)$$

where $\beta'_{i,k}$ is the reliability index of the k -th failure mode, and $\alpha'_{i,k} = (\alpha'_{i,k1}, \dots, \alpha'_{i,kL_1}, \dots, \alpha'_{i,kL_p})$ is the directional cosine. If one failure mode occurs, the entire component fails. As a result, the component is regarded as a series system. The reliability is then given by

$$R_i = \Phi_k(-\boldsymbol{\mu}_i, \boldsymbol{\Sigma}_i) \quad (38)$$

where $\boldsymbol{\mu}_i = (-\beta'_{i1}, -\beta'_{i2}, \dots, -\beta'_{iq})$ and $\boldsymbol{\Sigma}_i = [\rho_{kj}] = \alpha'_{i,k} \alpha'^T_{i,j}$ ($k, j=1, 2, \dots, q$). The reliability index of the component is therefore given by

$$\beta_i = \Phi^{-1}(R_i) \quad (39)$$

Each component failure mode has its own PSFs for the shared loads. To enable the component supplier to produce PSFs for the entire component with a single limit-state function, we employ the method of the equivalent linear safety margin discussed in [19], which is given by

$$G_i(\mathbf{U}) = \beta_i + \alpha_{i,1}U_{1\sim L} + \cdots + \alpha_{i,L_1}U_{L_1} + \cdots + \alpha_{i,L_p}U_{L_p} \quad (40)$$

Eq. (40) represents only one limit-state function no matter how many failure modes a component may have. The coefficients of the random variables on the right-hand side are determined by the sensitivity of β_i with respect to the basic random variables.

$$\alpha_{i,j} = \frac{\frac{\partial \beta_i}{\partial U_j}}{\left(\sum_{j=1}^n \left(\frac{\partial \beta_i}{\partial U_j} \right)^2 \right)^{1/2}}, j = 1, 2, \dots, n \quad (41)$$

The derivatives in Eq. (41) are evaluated numerically. Increase U_j , $j = 1, 2, \dots, n$, by a small amount $\varepsilon_j > 0$, and then let $\boldsymbol{\varepsilon}_j = (0, \dots, \varepsilon_j, \dots, 0)$. The new basic variables become

$$\mathbf{U} = (U_1, U_2, \dots, U_{j-1}, U_j + \varepsilon_j, U_{j+1}, \dots, U_n) \quad (42)$$

This gives a new reliability index $\beta_{i,j}$ by

$$\beta_{i,j} = -\Phi^{-1} \left(1 - \Phi(-\beta_i - \boldsymbol{\alpha}_i \boldsymbol{\varepsilon}_j^T) \right) \quad (43)$$

The derivative is then given by

$$\frac{\partial \beta_i}{\partial U_j} \approx \frac{\beta_{i,j} - \beta_i}{\varepsilon} \quad (44)$$

Since the counterpart in the X-space of the MPP of L_j is calculated by $L_j^* = \gamma_{i,j} \mu_{L_j}$ and in the U-space the MPP is given by $u_j^* = -\beta_i \alpha_{i,L_j}$, the component PSFs for the shared loads are computed by

$$\gamma_{i,j} = \frac{F_{L_j}^{-1}(\Phi(-\beta_i \alpha_{i,L_j}))}{\mu_{L_j}} \quad (j = 1, 2, \dots, p) \quad (45)$$

Then component suppliers provide the component reliability R_i and PSFs $\gamma_{i,j}$ to system designers. R_i and $\gamma_{i,j}$ do not include proprietary information such as component limit-state functions, which may involve structures, dimensions, and material properties.

Note that although the above discussions are based on FORM, other reliability methods can also be used. If SORM is used, the procedure will be the same. Component suppliers only need to replace β_i obtained by FORM with that by SORM.

6. COMPLETE PROCEDURE

We now discuss the complete procedure of using the PSF method. The procedure consists component-level and stem-level analyses. First, we summarize the information known at both levels.

- 1) Component-level: limit-state functions $g_{i,k}(\mathbf{X})$ for the k -th failure mode of the i -th component, and the distributions of \mathbf{X} (basic random variables and system loads).
- 2) System-level: the probability of failure of each component p_{fi} , the PSF $\gamma_{i,j}$ for each system load, and the distributions of system loads. The former two pieces of information are produced by the component-level analysis.

The flowchart of the complete procedure is then provided as shown in Figure1, which shows the analysis procedure in detail.

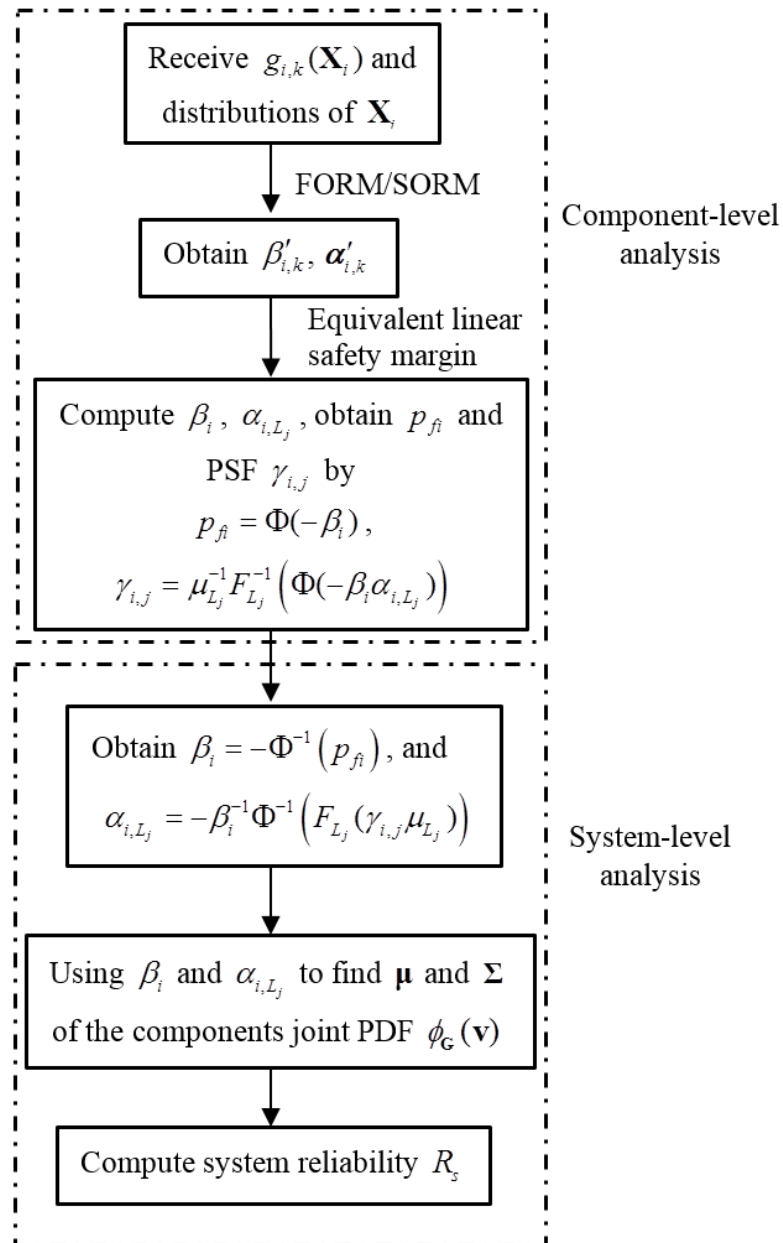

Figure 1 Flowchart of the proposed method

7. EXAMPLES

In this section, the PSF method is applied to two examples. The first mathematical example is used to demonstrate the procedure of using the proposed method for system reliability estimation while the other example shows an engineering application.

7.1 MATHEMATICAL EXAMPLE

A system consists of two components, and each component has two failure modes (FMs). The components are provided by two different outside suppliers. We now discuss the proposed method through both component-level and system-level analysis.

7.1.1 Component-Level Analysis. Component 1 has two limit-state functions for FM1 and FM2, respectively, which are given by

$$g_{1,1}(\mathbf{X}_1) = -452 + 8.6X_{1,1} + 3.6X_{1,2} + X_{1,3} \quad (46)$$

$$g_{1,2}(\mathbf{X}_1) = -1035 + X_{1,1}^3 + 2X_{1,2}^2 - 3X_{1,3} \quad (47)$$

The independent basic random variables are $\mathbf{X}_1 = (X_{1,1}, X_{1,2}, X_{1,3}) = (X_{1,1}, \mathbf{L})$, and $\mathbf{L} = (L_1, L_2)$ contains two shared loads. Their distributions are given in Table 1.

Table 1. Distribution of basic random variables for Component 1

Variable	Distribution
$X_{1,1}$	$N(10, 0.8^2)$
$X_{1,2}(L_1)$	$N(30, 1.5^2)$
$X_{1,3}(L_2)$	$N(300, 10^2)$

The supplier uses FORM for reliability analysis for FM1 and obtain the approximated limit-state function given by

$$G_{1,1}(\mathbf{U}) = \beta'_{1,1} + \alpha'_{1,11}U_{1,1} + \alpha'_{1,1L_1}U_{1L_1} + \alpha'_{1,1L_2}U_{1L_2} \quad (48)$$

where $\beta'_{1,1} = 3.1614$, $\alpha'_{1,11} = 0.5179$, $\alpha'_{1,1L_1} = 0.4065$, and $\alpha'_{1,1L_2} = 0.7527$. The probability of failure is $p_{f1,1} = \Phi(-\beta'_{1,1}) = 7.8498 \times 10^{-4}$.

For FM2, the suppliers applies SORM due to the higher nonlinearity. Then the reliability index and corresponding directional cosine are obtained by $\beta'_{1,2} = 3.3435$, $\alpha'_{1,21} = 0.7012$, $\alpha'_{1,2L_1} = 0.7006$, and $\alpha'_{1,2L_2} = -0.1320$. The approximated linear limit-state function is given by

$$G_{1,2}(\mathbf{U}) = \beta'_{1,2} + \alpha'_{1,21}U_{1,1} + \alpha'_{1,2L_1}U_{L_1} + \alpha'_{1,2L_2}U_{L_2} \quad (49)$$

The probability of failure is $p_{f1,2} = \Phi(-\beta'_{1,2}) = 4.1359 \times 10^{-4}$.

Since the joint PDF of $G_{1,1}(\mathbf{U})$ and $G_{1,2}(\mathbf{U})$ follows multivariate normal distribution with the mean $\boldsymbol{\mu}_1$ given by

$$\boldsymbol{\mu}_1 = (-\beta'_{1,1}, -\beta'_{1,2}) = (-3.1614, -3.3435) \quad (50)$$

and $\boldsymbol{\Sigma}_1$ given by

$$\boldsymbol{\Sigma}_1 = \begin{bmatrix} 1 & \rho_{12} \\ \rho_{21} & 1 \end{bmatrix} = \begin{bmatrix} 1 & 0.5485 \\ 0.5485 & 1 \end{bmatrix} \quad (51)$$

Thus, the probability of failure of component 1 is calculated by

$$p_{f1} = 1 - \Phi_2(-\boldsymbol{\mu}_1; \boldsymbol{\Sigma}_1) = 1.1650 \times 10^{-3} \quad (52)$$

The corresponding reliability index is $\beta_1 = -\Phi^{-1}(p_{f1}) = 3.0446$.

The component supplier also needs to provide the PSFs for the system load $\mathbf{L}=(L_1, L_2)$ to system designers. Now we discuss how the component supplier obtains the PSFs using the equivalent linear safety margin approach [20].

The component equivalent reliability index is β_1 . Set $\varepsilon = 0.01$, with $\boldsymbol{\varepsilon}_1 = (\varepsilon, 0, 0)$, we have

$$\begin{aligned} -\boldsymbol{\beta}_1^T - \boldsymbol{\alpha}_1 \boldsymbol{\varepsilon}_1^T &= \begin{bmatrix} -\beta'_{1,1} \\ -\beta'_{1,2} \end{bmatrix} - \begin{bmatrix} \alpha'_{1,11} & \alpha'_{1,1L_1} & \alpha'_{1,1L_2} \\ \alpha'_{1,21} & \alpha'_{1,2L_1} & \alpha'_{1,2L_2} \end{bmatrix} \begin{bmatrix} \varepsilon \\ 0 \\ 0 \end{bmatrix} \\ &= \begin{bmatrix} -3.1614 \\ -3.3435 \end{bmatrix} - \begin{bmatrix} 0.5179 & 0.4065 & 0.7527 \\ 0.7012 & 0.7006 & -0.1320 \end{bmatrix} \begin{bmatrix} 0.01 \\ 0 \\ 0 \end{bmatrix} = \begin{bmatrix} -3.1666 \\ -3.3505 \end{bmatrix} \end{aligned} \quad (53)$$

According to Eq. (43), the new reliability index is

$$\beta_{1,1}(\boldsymbol{\varepsilon}_1) = -\Phi^{-1}(1 - \Phi_2(-3.1666, -3.3505; \boldsymbol{\Sigma}_1)) = 3.0506 \quad (54)$$

Therefore,

$$\alpha_{1,1} = \left. \frac{\partial \beta_1}{\partial \varepsilon} \right|_{\boldsymbol{\varepsilon}_1=0} = \frac{\beta_{1,1}(\boldsymbol{\varepsilon}_1) - \beta_1}{\varepsilon} = \frac{3.0506 - 3.0446}{0.01} = 0.6051 \quad (55)$$

Similarly, with $\boldsymbol{\varepsilon}_2 = (0, \varepsilon, 0)$, we have

$$\beta_{1,L_1}(\boldsymbol{\varepsilon}_2) = -\Phi^{-1}(1 - \Phi_2(-3.1655, -3.3505; \boldsymbol{\Sigma}_1)) = 3.0499 \quad (56)$$

Therefore,

$$\alpha_{1,2} = \alpha_{1,L_1} = \left. \frac{\partial \beta_1}{\partial \varepsilon} \right|_{\boldsymbol{\varepsilon}_2=0} = \frac{\beta_{1,L_1}(\boldsymbol{\varepsilon}_2) - \beta_1}{\varepsilon} = \frac{3.0499 - 3.0446}{0.01} = 0.5292 \quad (57)$$

Likewise, with $\boldsymbol{\varepsilon}_3 = (0, 0, \varepsilon)$, we have

$$\beta_{1,L_2}(\boldsymbol{\varepsilon}_3) = -\Phi^{-1}(1 - \Phi_2(-3.1690, -3.3422; \boldsymbol{\Sigma}_1)) = 3.0492 \quad (58)$$

We then have

$$\alpha_{1,3} = \alpha_{1,L_2} = \left. \frac{\partial \beta_1}{\partial \varepsilon} \right|_{\varepsilon_3=0} = \frac{\beta_{1,L_2}(\varepsilon_3) - \beta_1}{\varepsilon} \approx \frac{3.0492 - 3.0446}{0.01} = 0.4586 \quad (59)$$

By normalizing $(\alpha_{1,1}, \alpha_{1,2}, \alpha_{1,3})$, we obtain a unit vector of $(0.6538, 0.5718, 0.4955)$.

Note that $\alpha_{1,2} = \alpha_{1,L_1}$ and $\alpha_{1,3} = \alpha_{1,L_2}$, the equivalent safety margin of component 1 is given by

$$\begin{aligned} G_1(\mathbf{U}) &= \beta_1 + \alpha_{1,1}U_{1,1} + \alpha_{1,L_1}U_{L_1} + \alpha_{1,L_2}U_{L_2} \\ &= 3.0446 + 0.6538U_{1,1} + 0.5718U_{L_1} + 0.4955U_{L_2} \end{aligned} \quad (60)$$

The partial safety factors $\gamma_{1,1}$ for load L_1 is then calculated by

$$\gamma_{1,1} = \frac{F_{L_1}^{-1}(\Phi(-\beta_1 \alpha_{1,L_1}))}{\mu_{L_1}} = \frac{27.3884}{30} = 0.9129 \quad (61)$$

Similarly, the partial safety factors $\gamma_{1,2}$ for load L_2 is calculated by

$$\gamma_{1,2} = \frac{F_{L_2}^{-1}(\Phi(-\beta_1 \alpha_{1,L_2}))}{\mu_{L_2}} = \frac{284.9148}{300} = 0.9497 \quad (62)$$

Then the supplier of component 1 provides $p_{f1} = 1.1650 \times 10^{-3}$, $\gamma_{1,1} = 0.9129$, and $\gamma_{1,2} = 0.9497$ to system designers.

Component 2 also has two limit-state functions given by

$$g_{2,1}(\mathbf{X}_2) = 2X_{2,2}^2 - 3X_{2,3} - 17X_{2,4} \quad (63)$$

$$g_{2,2}(\mathbf{X}_2) = X_{2,2}^2 - 2X_{2,3} - X_{2,4} \quad (64)$$

The independent basic random variables are $\mathbf{X}_2 = (X_{2,2}, X_{2,3}, X_{2,4}) = (L_1, L_2, X_{2,4})$ and (L_1, L_2) are the same shared loads as those in FM1. The details are given in Table 2.

Table 2 Distribution of basic random variables for Component 2

Variable	Distribution
$X_{2,2}(L_1)$	$N(30, 1.5^2)$
$X_{2,3}(L_2)$	$N(300, 10^2)$
$X_{2,4}$	$N(20, 2^2)$

The supplier of component 2 uses FORM to conduct reliability analysis for both failure modes. They obtain the component probability of failure

$$p_{f2} = 1 - \Phi_2(-\boldsymbol{\mu}_2; \boldsymbol{\Sigma}_2) = 6.8864 \times 10^{-4} \quad (65)$$

in which $\boldsymbol{\mu}_2 = (-\beta'_{2,1}, -\beta'_{2,2}) = (-3.2559, -3.2848)$ and

$$\boldsymbol{\Sigma}_2 = \begin{bmatrix} 1 & 0.9799 \\ 0.9799 & 1 \end{bmatrix}.$$

The equivalent reliability index is given by

$$\beta_2 = -\Phi^{-1}(p_{f2}) = 3.1994 \quad (66)$$

The partial safety factor $\gamma_{2,1}$ for load L_1 is calculated by

$$\gamma_{2,1} = \frac{F_{L_1}^{-1}(\Phi(-\beta_2 \alpha_{2L_1}))}{\mu_{L_1}} = \frac{25.3615}{30} = 0.8454 \quad (67)$$

and $\gamma_{2,2}$ for load L_2 is given by

$$\gamma_{2,2} = \frac{F_{L_2}^{-1}(\Phi(-\beta_2 \alpha_{2L_2}))}{\mu_{L_2}} = \frac{307.0055}{300} = 1.0234 \quad (68)$$

Then $p_{f2} = 6.8864 \times 10^{-4}$, $\gamma_{2,1} = 0.8454$, and $\gamma_{2,2} = 1.0234$ are provided to system designers.

7.1.2 System-Level Analysis. To calculate the system reliability, system designers need to find the joint PDF of components 1 and 2. As discussed in Sec. 4, the joint PDF follows a multivariate normal distribution. The task of the system designers is therefore to find the mean vector $\boldsymbol{\mu}$ and covariance matrix $\boldsymbol{\Sigma}$. With the given p_{f1} and p_{f2} , $\boldsymbol{\mu}$ is obtained by

$$\boldsymbol{\mu} = (-\Phi^{-1}(p_{f1}), -\Phi^{-1}(p_{f2})) = (-3.0446, -3.1994) \quad (69)$$

and $\boldsymbol{\Sigma}$ is determined by

$$\boldsymbol{\Sigma} = \begin{bmatrix} 1 & (\alpha_{1,L_1}, \alpha_{1,L_2})(\alpha_{2,L_1}, \alpha_{2,L_2})^T \\ (\alpha_{1,L_1}, \alpha_{1,L_2})(\alpha_{2,L_1}, \alpha_{2,L_2})^T & 1 \end{bmatrix} = \begin{bmatrix} 1 & 0.4442 \\ 0.4442 & 1 \end{bmatrix} \quad (70)$$

where α_{i,L_j} ($i, j = 1, 2$) is calculated by

$$\alpha_{1,L_1} = -\beta_1^{-1}\Phi^{-1}(F_{L_1}(\gamma_{1,1}\mu_{L_1})) = 0.5718 \quad (71)$$

$$\alpha_{1,L_2} = -\beta_1^{-1}\Phi^{-1}(F_{L_2}(\gamma_{1,2}\mu_{L_2})) = 0.4955 \quad (72)$$

$$\alpha_{2,L_1} = -\beta_2^{-1}\Phi^{-1}(F_{L_1}(\gamma_{2,1}\mu_{L_1})) = 0.9665 \quad (73)$$

$$\alpha_{2,L_2} = -\beta_2^{-1}\Phi^{-1}(F_{L_2}(\gamma_{2,2}\mu_{L_2})) = -0.2190 \quad (74)$$

Thus the system probability of failure is given by

$$p_{fs} = 1 - \Phi_2(-\boldsymbol{\mu}; \boldsymbol{\Sigma}) = 1.8206 \times 10^{-3} \quad (75)$$

7.1.3 Result Validation. To validate the result from the PSF method, we calculate the true p_{fs} using MCS method as if all the component design details, including all the component limit-state functions and the information in Tables 1 and 2, were available.

For comparison, we also compute p_{fs} using the independence assumption method, which is given by

$$p_{fs,ind} = 1 - (1 - p_{f1,ind}) \times (1 - p_{f2,ind}) \quad (76)$$

in which

$$p_{f1,ind} = 1 - (1 - p_{f11}) \times (1 - p_{f12}) = 1.1982 \times 10^{-3} \quad (77)$$

$$p_{f2,ind} = 1 - (1 - p_{f21}) \times (1 - p_{f22}) = 1.0751 \times 10^{-3} \quad (78)$$

Plugging Eqs. (77) and (78) into Eq. (76), we have

$$p_{fs,ind} = 2.2721 \times 10^{-3} \quad (79)$$

The results from different methods are summarized in Table 3, which indicates that the PSF method produces much higher accuracy than the independence assumption method. The accuracy is measured by the relative error with respect to the MCS solution. The dependency between components is automatically accommodated in the proposed method. The large error from independence assumption method is mainly caused by the high correlation between component states.

Table 3 Results from different methods

	PSF	Independence Assumption	True Value
p_{fs}	1.8206×10^{-3}	2.2721×10^{-3}	1.7689×10^{-3}
Error (%)	2.92	28.44	N/A

7.2 ENGINEERING EXAMPLE

A hoisting device has two components as shown in Figure 2. Component 1 consists of two cables. Two loads L_1 and L_2 are applied to Component 1. L_1 and L_2 are independent, and the mean value of L_2 is much bigger than that of L_1 . Component 2 is a truss structure and is composed of two rods. Components 1 and 2 are designed and manufactured by two independent outside suppliers, and no design details are available to the system-level analysis. System designers ask the component suppliers to perform reliability analysis under the system loads L_1 and L_2 and to provide component reliabilities and PSFs for the loads.

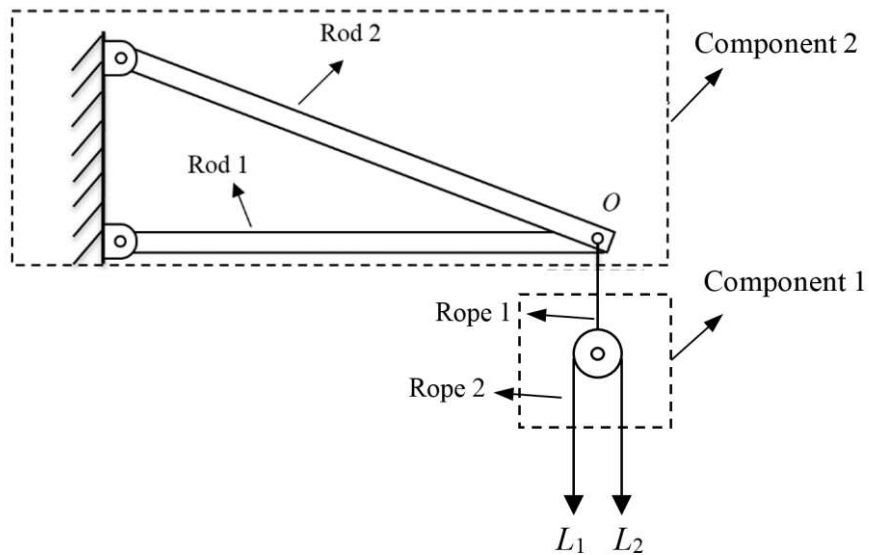

Figure 2 A hoisting device

7.2.1 Component-Level Analysis. Component 1 has two failure modes due to failures of cables 1 and 2. The corresponding two limit-state functions are given by

$$g_{1,1}(\mathbf{X}_1) = S_1 - \frac{L_1 + L_2}{\pi d_1^2 / 4} \quad (80)$$

$$g_{1,2}(\mathbf{X}_1) = S_2 - \frac{L_2}{\pi d_2^2 / 4} \quad (81)$$

The details known by the suppliers of Component 1 are given in Table 4.

Table 4 Distribution of basic random variables for Component 1

Random variables	Distribution
$X_{1,1}$ (d_1): diameter of cable 1	$N(5 \times 10^{-3}, (1 \times 10^{-4})^2)$ m
$X_{1,2}$ (d_2): diameter of cable 2	$N(4 \times 10^{-3}, (1 \times 10^{-4})^2)$ m
$X_{1,3}$ (S_1): resistance of cable 1	$N(70, 1^2)$ MPa
$X_{1,4}$ (S_2): resistance of cable 2	$N(95, 12^2)$ MPa
$X_{1,5}$ (L_1): load 1	$\log N(250, 30^2)$ N
$X_{1,6}$ (L_2): load 2	$\log N(550, 100^2)$ N

The supplier of Component 1 uses FORM for FM1 and then obtains $\beta'_{1,1} = 3.8555$, and directional cosines $\alpha'_{1,1L_1} = -0.1604$ and $\alpha'_{1,1L_2} = -0.9451$ with respect to L_1 and L_2 , respectively. The probability of failure is computed by $p_{f11} = \Phi(-\beta'_{1,1}) = 5.7744 \times 10^{-5}$.

The supplier then uses SORM for FM2 and obtains $\beta'_{1,2} = 3.2802$, $\alpha'_{1,2L_1} = 0$, and $\alpha'_{1,2L_2} = -0.6989$. The probability of failure is then given by $p_{f1,2} = \Phi(-\beta'_{1,2}) = 5.1873 \times 10^{-4}$.

The joint PDF of FM1 and FM2 is then determined by the mean

$$\boldsymbol{\mu}_1 = (-\beta'_{1,1}, -\beta'_{1,2}) = (-3.8555, -3.2802) \quad (82)$$

and the covariance matrix

$$\boldsymbol{\Sigma}_1 = \begin{bmatrix} 1 & 0.6604 \\ 0.6604 & 1 \end{bmatrix} \quad (83)$$

Thus, the probability of failure of Component 1 is calculated by

$$p_{f1} = 1 - \Phi_2(-\boldsymbol{\mu}_1; \boldsymbol{\Sigma}_1) = 5.6356 \times 10^{-4} \quad (84)$$

The corresponding reliability index is $\beta_1 = -\Phi^{-1}(p_{f1}) = 3.2567$.

Based on the equivalent limit-state function of Component 1, the PSFs $\gamma_{1,1}$ for L_1 and $\gamma_{1,2}$ for L_2 are calculated and are given by $\gamma_{1,1} = 1.0064$ and $\gamma_{1,2} = 1.4418$. The supplier then provides p_{f1} , $\gamma_{1,1}$ and $\gamma_{1,2}$ to system designers.

The two failure modes of Component 2 are caused by excessive axial stresses developed in Rods 1 and 2. The limit-state functions for the two failure modes are given by

$$g_{2,1}(\mathbf{X}_2) = S_3 - \frac{8(L_1 + L_2)a_2}{\sqrt{a_2^2 - a_1^2} (\pi d_3^2)} \quad (85)$$

$$g_{2,2}(\mathbf{X}_2) = S_4 - \frac{8(L_1 + L_2)a_1}{\sqrt{a_2^2 - a_1^2} (\pi d_4^2)} \quad (86)$$

The distributions of random variables are given in Table 5.

The supplier of Component 2 applies FORM to both failure modes and obtains the reliability index and directional cosines for the loads. For FM1, the supplier obtains

$\beta'_{2,1} = 2.7199$, $\alpha'_{2,1L_1} = -0.1907$, and $\alpha'_{2,1L_2} = -0.9299$. For FM2, the results are

$\beta'_{2,2} = 2.8845$, $\alpha'_{2,2L_1} = -0.1789$, and $\alpha'_{2,2L_2} = -0.8697$. The probability of failure is then calculated by $p_{f_2} = 1 - \Phi_2(-\boldsymbol{\mu}_2; \boldsymbol{\Sigma}_2) = 4.3144 \times 10^{-3}$, and the reliability index is $\beta_2 = -\Phi^{-1}(p_{f_2}) = 2.6264$. The PSFs $\gamma_{2,1} = 1.0610$ for load L_1 and $\gamma_{2,2} = 1.4506$ for load L_2 are also obtained. The supplier then provides p_{f_2} , $\gamma_{2,1}$, and $\gamma_{2,2}$ to system designers.

Table 5 Distribution of basic random variables for Component 2

Random variables	Distribution
$X_{2,1} (a_1)$: length of Rod 1	$N(0.9, (1 \times 10^{-4})^2)$ m
$X_{2,2} (a_2)$: length of Rod 2	$N(1.8, (1 \times 10^{-4})^2)$ m
$X_{2,3} (d_3)$: diameter of Rod 1	$N(6 \times 10^{-3}, (1 \times 10^{-4})^2)$ m
$X_{2,4} (d_4)$: diameter of Rod 2	$N(6 \times 10^{-3}, (1 \times 10^{-4})^2)$ m
$X_{2,5} (S_3)$: resistance of Rod 1	$N(95, 3^2)$ MPa
$X_{2,6} (S_4)$: resistance of Rod 2	$N(50, 3^2)$ MPa
$X_{2,7} (L_1)$: load 1	$N(250, 30^2)$ N
$X_{2,8} (L_2)$: load 2	$N(550, 100^2)$ N

7.2.2 System-Level Analysis. With the provided component probabilities of failure p_{f_1} , and p_{f_2} ; PSFs $\gamma_{1,1}$, $\gamma_{1,2}$, $\gamma_{2,1}$ and $\gamma_{2,2}$ for the system loads, system designers build the joint CDF of Components 1 and 2, which follows a multivariate normal distribution with the mean

$$\boldsymbol{\mu} = (-\Phi^{-1}(p_{f_1}), -\Phi^{-1}(p_{f_2})) = (-3.2567, -2.6264) \quad (87)$$

and the covariance matrix given by

$$\Sigma = \begin{bmatrix} 1 & (\alpha_{1,L_1}, \alpha_{1,L_2})(\alpha_{2,L_1}, \alpha_{2,L_2})^T \\ (\alpha_{1,L_1}, \alpha_{1,L_2})(\alpha_{2,L_1}, \alpha_{2,L_2})^T & 1 \end{bmatrix} = \begin{bmatrix} 1 & 0.7072 \\ 0.7072 & 1 \end{bmatrix} \quad (88)$$

where α_{i,L_j} ($i, j = 1, 2$) is given by

$$\alpha_{1,L_1} = -\beta_1^{-1} \Phi^{-1}(F_{L_1}(\gamma_{1,1}, \mu_{L_1})) = -0.0163 \quad (89)$$

$$\alpha_{1,L_2} = -\beta_1^{-1} \Phi^{-1}(F_{L_2}(\gamma_{1,2}, \mu_{L_2})) = -0.7462 \quad (90)$$

$$\alpha_{2,L_1} = -\beta_2^{-1} \Phi^{-1}(F_{L_1}(\gamma_{2,1}, \mu_{L_1})) = -0.1937 \quad (91)$$

$$\alpha_{2,L_2} = -\beta_2^{-1} \Phi^{-1}(F_{L_2}(\gamma_{2,2}, \mu_{L_2})) = -0.9435 \quad (92)$$

Thus the system probability of failure is given by

$$p_{fs} = 1 - \Phi_2(-\boldsymbol{\mu}; \Sigma) = 4.6386 \times 10^{-3} \quad (93)$$

7.2.3 Result Validation. We also calculate the true system probability of failure using MCS method and the independence assumption method, and the results are shown in Table 6.

Table 6 Results from different methods

	PSF	Independence Assumption	True Value
P_{fs}	4.6386×10^{-3}	5.7917×10^{-3}	4.8540×10^{-3}
Error (%)	4.43	19.32	N/A

The results show that the proposed method outperforms the independence assumption method with a relatively higher accuracy even with limited information available for system reliability analysis.

8. CONCLUSIONS

This work develops a new system reliability method to accurately estimate product reliability with only component reliability and partial safety factors for shared system loads. The new method provides a solution to the challenge for accurate system reliability prediction when component design details are inaccessible to system designers because of outsourcing. The new method is more accurate than the traditional independence assumption method. The new strategy is for system designers to construct equivalent component limit-state functions using the partial safety factors for shared system loads provided by component suppliers. Then the joint probability density function is obtained at the system level, thereby leading to accurate system reliability prediction without revealing proprietary details of outsourced components.

The proposed method is applicable to series systems whose failures are caused by excessive stresses due to random loads. It is assumed that the shared loads are only common random variables between the components of the system. If there are other common variables, the proposed method can still work as long as the corresponding partial safety factors are provided by component suppliers. Our future work will focus on extending the proposed method to complicated systems such as parallel or mix systems.

ACKNOWLEDGEMENTS

This material is based upon work supported by the National Science Foundation under grants CMMI 1562593 and the Intelligent Systems Center at the Missouri University of Science and Technology.

REFERENCES

- [1] Click, R. L., and Duening, T. N., 2004, Business process outsourcing: the competitive advantage, John Wiley & Sons.
- [2] Lacity, M. C., and Willcocks, L., 2000, Global information technology outsourcing: In search of business advantage, John Wiley & Sons, Inc.
- [3] Fiondella, L., and Xing, L., "Reliability of two failure mode systems subject to correlated failures," Proc. Proceedings - Annual Reliability and Maintainability Symposium.
- [4] Littlefield, S., Mazzuchi, T., and Sarkani, S., "Predicting reliability in design of complex systems with common-cause failures and time-varying failure rates," Proc. SysCon 2012 - 2012 IEEE International Systems Conference, Proceedings, pp. 502-506.
- [5] Cruse, T. A., 1997, Reliability-based mechanical design, CRC Press.
- [6] Hoyland, A., and Rausand, M., 2004, System reliability theory: models, statistical methods, and applications, NJ: Wiley-Interscience.
- [7] Ditlevsen, O., 1979, "Narrow reliability bounds for structural systems," Journal of structural mechanics, 7(4), pp. 453-472.
- [8] Yong Cang, Z., 1993, "High-order reliability bounds for series systems and application to structural systems," Computers and Structures, 46(2), pp. 381-386.
- [9] Hu, Z., and Du, X., 2017, "System reliability prediction with shared load and unknown component design details," AI EDAM, 31(3), pp. 223-234.
- [10] Hu, Z., and Du, X., "A physics-based reliability method for components adopted in new series systems," Proc. 2016 Annual Reliability and Maintainability Symposium (RAMS), IEEE, pp. 1-7.
- [11] Hu, Z., and Du, X., 2018, "An exploratory study for predicting component reliability with new load conditions," Frontiers of Mechanical Engineering, pp. 1-9.
- [12] Yu, S., Wang, Z., and Meng, D., 2018, "Time-variant reliability assessment for multiple failure modes and temporal parameters," Structural and Multidisciplinary Optimization, pp. 1-13.
- [13] Yu, S., and Wang, Z., 2018, "A novel time-variant reliability analysis method based on failure processes decomposition for dynamic uncertain structures," Journal of Mechanical Design, 140(5), p. 051401.

- [14] Yu, S., Wang, Z., and Zhang, K., 2018, "Sequential time-dependent reliability analysis for the lower extremity exoskeleton under uncertainty," *Reliability Engineering & System Safety*, 170, pp. 45-52.
- [15] Kumar, D., and Westberg, U., 1996, "Proportional hazards modeling of time-dependent covariates using linear regression: a case study [mine power cable reliability]," *IEEE Transactions on Reliability*, 45(3), pp. 386-392.
- [16] Cardoso, J. B., de Almeida, J. R., Dias, J. M., and Coelho, P. G., 2008, "Structural reliability analysis using Monte Carlo simulation and neural networks," *Advances in Engineering Software*, 39(6), pp. 505-513.
- [17] Hu, Z., and Du, X., 2017, "System reliability analysis with in-house and outsourced components," 2017 2nd International Conference on System Reliability and Safety, IEEE, Milan, Italy.
- [18] Hu, Z., and Du, X., 2018, "Integration of Statistics- and Physics-Based Methods—A Feasibility Study on Accurate System Reliability Prediction," *Journal of Mechanical Design*, 140(7), p. 074501.
- [19] Gollwitzer, S., and Rackwitz, R., 1983, "Equivalent components in first-order system reliability," *Reliability Engineering*, 5(2), pp. 99-115.
- [20] Roscoe, K., Diermanse, F., and Vrouwenvelder, T., 2015, "System reliability with correlated components: Accuracy of the Equivalent Planes method," *Structural Safety*, 57, pp. 53-64.
- [21] Rosenblatt, M., 1952, "Remarks on a multivariate transformation," *The annals of mathematical statistics*, 23(3), pp. 470-472.
- [22] Mansour, R., and Olsson, M., 2014, "A closed-form second-order reliability method using noncentral chi-squared distributions," *Journal of Mechanical Design*, 136(10), p. 101402.
- [23] Choi, S.-K., Grandhi, R., and Canfield, R. A., 2006, *Reliability-based structural design*, Springer Science & Business Media.
- [24] Ayyub, B. M., and White, G. J., 1987, "Reliability-conditioned partial safety factors," *Journal of Structural Engineering*, 113(2), pp. 279-294.
- [25] Hu, Z., and Du, X., "A Partial Safety Factor Method for System Reliability Prediction With Outsourced Components," *Proc. ASME 2018 International Design Engineering Technical Conferences and Computers and Information in Engineering Conference*, American Society of Mechanical Engineers, pp. V02BT03A050-V002BT003A050.

SECTION

2. CONCLUSIONS

The objective of this work is to investigate the feasibility of accurately predicting system reliability with both in-house and outsourced components. Since the design details of outsourced components are usually proprietary to the suppliers and are unknown to system designers, it is challenging to estimate reliabilities of outsourced components with only limited information, making it difficult to estimate system reliability accurately.

Four methods are developed to address this issue. The first method rebuilds component reliability function using only limited reliability data with respect to component loads, thereby estimating system reliability statistically. The second method employs two-class Support Vector Machine (SVM) to approximate the limit-state functions of outsourced components. The joint probability density function (PDF) of all the components can be obtained, which produces accurate system reliability prediction. The third method is an extension of the second one. A one-class SVM model with bias constraint is developed to reconstruct the limit-state functions of outsourced component given only the failure dataset. The joint PDF of all the components is then derived to estimate system reliability. The last method handles the case where no reliability dataset is available. A partial safety factor (PSF) method is proposed, which enables the component designers to provide sufficient information to system designers. Then system designers could rebuild the equivalent component limit-state functions and obtain the estimated joint PDF for system reliability analysis.

From the above studies, the following conclusions are drawn:

- (1) System reliability depends on reliabilities and dependencies between components.
- (2) The widely-used independency assumption method may produce large errors for systems with strongly dependent components.
- (3) Traditional physics-based reliability method such as First Order Reliability Method, relies on component limit-state functions, making it not applicable to systems with outsourced components.
- (4) Component reliability functions with respect to load can be reconstructed using probabilistic data with respect to failures at different load levels.
- (5) It is possible to reconstruct component limit-state functions using supervised learning methods, such as Support Vector Machines.
- (6) With available limit-state functions of all the components, it is able to derive the joint PDF for system reliability analysis.
- (7) If no reliability data are available, the limit-state functions of outsourced component can be approximated using partial safety factors.

The current research focuses on series system and assumes that the basic random variables are common loads, component dimensions, and properties of materials. In our future work, we will further improve the proposed methods and extend them to more complicated system configurations with multiple types of random variables, such as temperature, humidity, and pressure. In addition, more efforts will be committed to integrate all the proposed methods thereby producing a more comprehensive method for more general cases, in which systems are composed of outsourced components with reliability information given in different forms.

BIBLIOGRAPHY

- [1] Yang, F. X., Zhang, R. Q., and Zhu, K., 2017, "Should purchasing activities be outsourced along with production?," *European Journal of Operational Research*, 257(2), pp. 468-482.
- [2] Lacity, M. C., and Willcocks, L., 2000, *Global information technology outsourcing: In search of business advantage*, John Wiley & Sons, Inc.
- [3] Littlefield, S., Mazzuchi, T., and Sarkani, S., "Predicting reliability in design of complex systems with common-cause failures and time-varying failure rates," *Proc. SysCon 2012 - 2012 IEEE International Systems Conference, Proceedings*, pp. 502-506.
- [4] Ditlevsen, O., 1979, "Narrow reliability bounds for structural systems," *Journal of structural mechanics*, 7(4), pp. 453-472.
- [5] Yong Cang, Z., 1993, "High-order reliability bounds for series systems and application to structural systems," *Computers and Structures*, 46(2), pp. 381-386.
- [6] Cheng, Y., Conrad, D. C., and Du, X., 2017, "Narrower System Reliability Bounds With Incomplete Component Information and Stochastic Process Loading," *Journal of Computing and Information Science in Engineering*, 17(4), p. 041007.
- [7] Hu, Z., and Du, X., "A physics-based reliability method for components adopted in new series systems," *Proc. 2016 Annual Reliability and Maintainability Symposium (RAMS), IEEE*, pp. 1-7.
- [8] Du, X., and Hu, Z., 2012, "First order reliability method with truncated random variables," *Journal of Mechanical Design*, 134(9), p. 091005.
- [9] Chiralaksanakul, A., and Mahadevan, S., 2005, "First-order approximation methods in reliability-based design optimization," *Journal of Mechanical Design*, 127(5), pp. 851-857.
- [10] Zhao, Y. G., and Ono, T., 1999, "A general procedure for first/second-order reliability method (FORM/SORM)," *Structural Safety*, 21(2), pp. 95-112.
- [11] Du, X., and Sudjianto, A., 2004, "First order saddlepoint approximation for reliability analysis," *AIAA journal*, 42(6), pp. 1199-1207.
- [12] Hu, Z., and Du, X., 2018, "An exploratory study for predicting component reliability with new load conditions," *Frontiers of Mechanical Engineering*, pp. 1-9.
- [13] Choi, S.-K., Grandhi, R., and Canfield, R. A., 2006, *Reliability-based structural design*, Springer Science & Business Media.

- [14] Song, J., and Kang, W.-H., 2009, "System reliability and sensitivity under statistical dependence by matrix-based system reliability method," *Structural Safety*, 31(2), pp. 148-156.
- [15] Resende, L. C., Manso, L. A., Dutra, W. D., and da Silva, A. M. L., "Support Vector Machine application in composite reliability assessment," *Proc. Intelligent System Application to Power Systems (ISAP)*, 2015 18th International Conference on, IEEE, pp. 1-6.
- [16] Hu, Z., and Du, X., "System reliability analysis with in-house and outsourced components," *Proc. System Reliability and Safety (ICSRS)*, 2017 2nd International Conference on, IEEE, pp. 146-150.
- [17] Cardoso, J. B., de Almeida, J. R., Dias, J. M., and Coelho, P. G., 2008, "Structural reliability analysis using Monte Carlo simulation and neural networks," *Advances in Engineering Software*, 39(6), pp. 505-513.
- [18] Hu, Z., and Mahadevan, S., 2016, "A single-loop kriging surrogate modeling for time-dependent reliability analysis," *Journal of Mechanical Design*, 138(6), p. 061406.
- [19] Zhu, Z., and Du, X., 2016, "Reliability analysis with Monte Carlo simulation and dependent Kriging predictions," *Journal of Mechanical Design*, 138(12), p. 121403.
- [20] Kumar, D., and Westberg, U., 1996, "Proportional hazards modeling of time-dependent covariates using linear regression: a case study [mine power cable reliability]," *IEEE Transactions on Reliability*, 45(3), pp. 386-392.
- [21] Hu, Z., and Du, X., 2017, "System reliability prediction with shared load and unknown component design details," *AI EDAM*, 31(3), pp. 223-234.
- [22] Hu, Z., and Du, X., 2018, "Integration of Statistics- and Physics-Based Methods—A Feasibility Study on Accurate System Reliability Prediction," *Journal of Mechanical Design*, 140(7), p. 074501.
- [23] Hu, Z., Hu, Z., and Du, X., 2018, "One-class Support Vector Machines with a bias constraint and its application in system reliability prediction," *AI EDAM* (under review).
- [24] Hu, Z., and Du, X., 2018, "A Partial Safety Factor Method for System Reliability Prediction with Outsourced Components," *ASCE-ASME Journal of Risk and Uncertainty in Engineering Systems* (Accepted).

VITA

Zhengwei Hu was born in Shahe, Hebei, the People's Republic of China. He received his Bachelor of Science degree in Mechanical Engineering in 2007 from Yanshan University, Qinhuangdao, China. Then he continued his education in Yanshan University and received his Master of Science degree in Mechanical Engineering in 2010. He then worked as a Mechanical Engineer between 2010 and 2013 in the Research and Development Center of China First Heavy Industries, Tianjin, China. Zhengwei Hu started pursuing the degree of Doctor of Philosophy in the Department of Mechanical and Aerospace Engineering at Missouri University of Science and Technology in August 2014. He worked with Dr. Xiaoping Du in the areas of system reliability analysis with outsourced components and probabilistic engineering design. In May 2019, he received his Doctor of Philosophy in Mechanical Engineering from Missouri University of Science and Technology, Rolla, Missouri.