

---

Masters Theses

Student Theses and Dissertations

---

Summer 2010

## Energy expenditure analysis of redesigned mechanical assists for medium girder bridge

Karthik Kumar

Follow this and additional works at: [https://scholarsmine.mst.edu/masters\\_theses](https://scholarsmine.mst.edu/masters_theses)



Part of the [Mechanical Engineering Commons](#)

Department:

---

### Recommended Citation

Kumar, Karthik, "Energy expenditure analysis of redesigned mechanical assists for medium girder bridge" (2010). *Masters Theses*. 4782.

[https://scholarsmine.mst.edu/masters\\_theses/4782](https://scholarsmine.mst.edu/masters_theses/4782)

This thesis is brought to you by Scholars' Mine, a service of the Missouri S&T Library and Learning Resources. This work is protected by U. S. Copyright Law. Unauthorized use including reproduction for redistribution requires the permission of the copyright holder. For more information, please contact [scholarsmine@mst.edu](mailto:scholarsmine@mst.edu).



ENERGY EXPENDITURE ANALYSIS OF REDESIGNED MECHANICAL ASSISTS  
FOR MEDIUM GIRDER BRIDGE

by

KARTHIK KUMAR

A THESIS

Presented to the Faculty of the Graduate School of the

MISSOURI UNIVERSITY OF SCIENCE AND TECHNOLOGY

In Partial Fulfillment of the Requirements for the Degree

MASTER OF SCIENCE IN MECHANICAL ENGINEERING

2010

Approved by

Virgil Flanigan, Advisor  
K. Chandrashekhara  
Shubhender Kapila

© 2010

Karthik Kumar

All Rights Reserved

## ABSTRACT

U.S. Army bridge crew soldiers perform tough manual material handling (MMH) tasks during the assembly of a Medium Girder Bridge (MGB). The bridge parts are very heavy and are manually lifted from pallets, carried to the construction site and assembled with other bridge parts. An energy expenditure study on the soldiers handling the bridge parts revealed that the energy expenditure rate of the soldiers exceeds the NIOSH prescribed safety limit of 3.5 Kcal/min. This leads to high risk of musculoskeletal disorders.

The study deals with modifying the first redesign of mechanical assists for medium girder bridge (MGB) and studying the energy expended by soldiers during MGB construction while using the modified assists and comparing it to the energy expended by soldiers while using the current assists. The first redesign required minor modification to improve usability and performance. An effort was put to address these issues. The approach for this research involved redesign based on a field test performed with the first redesigned assists and observation of the bridge building process using recorded video tapes.

The thesis research involved design modifications, prototype manufacturing and energy expenditure study using Energy Expenditure Prediction Program (EPPP). The EPPP study revealed that the redesigned mechanical assists reduced the average energy expenditure rate of soldiers by 33%. The average team energy expenditure was reduced by 50%.

## ACKNOWLEDGMENTS

I am heartily thankful to my advisor, Dr. Virgil Flanigan whose encouragement, motivation and support enabled me to develop a better understanding of this area of research. I am deeply indebted to him for everything he has done for me from the time I met him.

I am grateful to Dr. K. Chandrashekhara, Department of Mechanical and Aerospace Engineering and Dr. Shubhender Kapila, Department of Chemistry for being on my committee.

I owe my sincere gratitude to my research guides Andrew Bodenhamer and Bradley Davis for providing me with excellent ideas and for working with me to completely understand all aspects of this project. Their experience on the medium girder bridge (MGB) was invaluable. I would also like to thank Dr. Alan Davison for giving me valuable suggestions and data on human factor engineering.

I am thankful to the Center for Environmental Sciences and Technology faculty and staff. I am indebted to Rusty Carlile for helping me in fabrication of the prototypes. I would also like to thank Sandesh Chandrasekhar, for working with me in fabrication of the prototypes and for helping me at a time of crisis.

Finally, I would like to thank my beloved family and friends for their continued support and encouragement throughout my career.

## TABLE OF CONTENTS

	Page
ABSTRACT.....	iii
ACKNOWLEDGMENTS .....	iv
LIST OF ILLUSTRATIONS.....	vii
LIST OF TABLES.....	ix
SECTION	
1. INTRODUCTION.....	1
1.1. HUMAN FACTOR ENGINEERING .....	1
1.2. MANUAL MATERIAL HANDLING .....	3
1.3. ENERGY EXPENDITURE PREDICTION.....	5
2. PROJECT DESCRIPTION .....	9
2.1. PROJECT OBJECTIVE .....	9
2.2. PROJECT BACKGROUND .....	10
2.2.1. Medium Girder Bridge (MGB).....	10
2.2.2. Major MGB Components .....	12
2.2.3. MGB Carry Tools .....	14
2.2.4. MGB Building Sequence .....	15
3. DESIGN METHODOLOGY .....	18
3.1. DESIGN PROCESS .....	18
3.2. MATERIAL SELECTION.....	19
3.3. DESIGN INPUTS.....	20
4. REDESIGN OF MECHANICAL ASSISTS .....	23
4.1. HAND TOOL REDESIGN .....	23
4.1.1. First Redesign .....	25
4.1.2. Design Modifications Required for the Hand Tools.....	26
4.1.3. Redesign of the Hand Tools.....	27
4.1.4. Carry Bar Redesign.....	27
4.1.5. Prototype Testing of Carry Bar.....	29
4.1.6. Carry Handle Redesign.....	29
4.1.7. Prototype Testing of Carry Handle.....	31

4.1.8. Bill Of Material.....	31
4.2. HAND TRUCK DESIGN.....	32
4.2.1. Factors Affecting Pushing and Pulling.....	33
4.2.2. First Design of Hand Truck.....	33
4.2.3. Modifications Required on the Hand Truck.....	36
4.2.4. Redesign of the Hand Truck.....	37
4.2.5. Final Prototype.....	41
4.2.6. Bill Of material.....	42
4.2.7. Prototype Testing of Hand truck.....	42
4.3. CRANE DESIGN.....	44
4.3.1. Requirements of a Crane System.....	44
4.3.2. First Crane Design.....	45
4.3.3. Modifications Required on the Crane System.....	47
4.3.4. Redesign of the Crane System.....	48
4.3.5. Prototype Testing of Crane System.....	52
5. ENERGY EXPENDITURE PREDICTION ANALYSIS.....	53
5.1. ENERGY EXPENDITURE PREDICTION PROGRAM.....	53
5.2. PARAMETER PREDICTION DURING BRIDGE BUILD.....	58
5.3. EEPP ANALYSIS OF CURRENT ASSISTS.....	61
5.3.1. EEPP Results Of Current Assists.....	64
5.4. EEPP ANALYSIS OF REDESIGNED ASSISTS.....	66
5.4.1. EEPP Results Of Redesigned Assists.....	67
5.5. COMPARISON OF EEPP ANALYSIS OF BOTH ASSISTS.....	69
5.5. CONCLUSIONS AND FUTURE WORK.....	74
APPENDIX.....	76
BIBLIOGRAPHY.....	77
VITA.....	79



## LIST OF ILLUSTRATIONS

Figure	Page
1.1. Equation for Energy Expenditure Rate Prediction.....	7
2.1. Configurations of MGB .....	10
2.2. Single Storey Bridge Configuration.....	11
2.3. Double Storey Bridge Configuration .....	11
2.4. Major Components of MGB and Their Weights .....	12
2.5. Carrying Tools for MGB .....	14
2.6. Pallet Loads.....	15
3.1. Roller Cart and Panel Erection Aid .....	21
4.1. Current Carrying Tools .....	24
4.2. First Redesign of Hand Tools .....	26
4.3. Redesigned Carry Bar .....	28
4.4. Redesigned Carry Bar Prototype .....	28
4.5. Carry Bar Prototype Failure.....	29
4.6. Redesigned Carry Handle .....	30
4.7. Fabricated Prototype of Carry Handle .....	31
4.8. Factors Affecting Pushing/Pulling.....	33
4.9. First Design of Hand Truck .....	34
4.10 Hand Truck Castor Failure.....	35
4.11. Hand Truck with Caterpillar Wheels .....	36
4.12. Hustler® Wheel Sub System. ....	38
4.13. Center Wheels of Redesigned Hand Truck.....	39
4.14. CAD Model of Hand Truck .....	40
4.15. Hand Truck Dimensions .....	41
4.16. Final Prototype of Hand Truck .....	42
4.17. Pushing Hand Truck on Grass and Asphalt .....	43
4.18. First Design of Crane System .....	46
4.19. First Crane Design Performing a Bottom Panel Lift .....	47

4.20. Welded Plates for Wire Rope Assembly .....	49
4.21. Badger 2500 Specifications .....	50
4.22. Hoist and Battery Mounting on Undercarriage.....	50
4.23. Redesigned Crane System.....	51
5.1. Job Descriptions on EEPP .....	57
5.2. Task Descriptions on EEPP .....	57
5.3. Job Energy Expenditure Summary .....	64
5.4. Total Task Energy Rate for Bridge Parts.....	65
5.5. Job Energy Expenditure Summary for Bridge Parts Using New Assists .....	68
5.6. Total Task Energy Rate for Bridge Parts Using New Assists .....	69
5.7. Task Energy Rate Comparison .....	70
5.8. Task Time Comparison.....	71
5.9. Team Energy Rate Comparison.....	72

**LIST OF TABLES**

Table	Page
2.1. MGB Major Component Dimensions .....	14
4.1. Bill of Material of Carry Bar and Carry Handle .....	32
4.2. Bill Of Material of Hand Truck with Cost Analysis.....	42
5.1. MGB Part Requirements for 12 Bay Bridge.....	62
5.2. Task Description and Parameter Values with Current Assists .....	63
5.3. Task Description and Parameter Values with Redesigned Assists.....	67

# 1. INTRODUCTION

## 1.1. HUMAN FACTORS ENGINEERING

International Ergonomics Association (IEA) defines Human factors engineering as follows:

“Human factors engineering is the scientific discipline concerning with the understanding of interactions among humans and other elements of a system, and the profession that applies theory, principles, data and other methods to design in order to optimize human well being and overall system performance.”

Human factors engineering is an interdisciplinary science. It involves engineering and medicine to study the human and the work environment. Human factors engineering involves applying knowledge of human capabilities to design of products, tools, processes, systems and work environments to enhance the efficiency of performing a job and thereby increasing productivity. It is necessary to consider human factors design at the initial stages of job design, as it helps to reduce the fatigue and stress level of a worker while performing a task thereby increasing the comfort level and productivity of the worker.

The main objectives [1] of Human factors are stated below:

- 1) To enhance the effectiveness and efficiency of a job or task. This includes convenience of use, reduced errors and increased productivity.
- 2) To enhance desired human values that include improved safety and comfort and reduced strain and fatigue level on the worker which in turn enhances job satisfaction and quality of life.

The approach [1] of human factors is the systematic application of relevant information about human capabilities, limitations, characteristics, behavior and motivation to the design of things. Human behavior when performing a job is studied to discover relevant information on human behavior and response to environment. Human factors engineering also involves evaluation of the designed product to ensure that all objectives are satisfied.

The goal of a human factors engineer is to optimize the performance of workers performing a job. Job analysis plays a crucial role in optimizing the worker performance. Job analysis describes the job pattern and musculoskeletal impairment associated with the job. Job analysis is vital for human factors engineering. Each job or task performed by a worker is studied and analyzed. The key factors [2] that are studied during job analysis are:

- 1) Person: It refers to the person who carries out the job. The number of people required, sex of the worker and the load carrying capacity are important elements.
- 2) Type of job: The type of job performed is another important factor. It is described in terms of the activities that constitute a job. The type of job is not limited to observable actions such as lifting, carrying, assembling, and holding but also to unobservable functions that lie behind these actions.
- 3) Purpose of job: It refers to the goal of the job. The goal may be objective and physically measurable or something that is subjective.

Job analysis plays a very crucial role in the study of manual material handling. Job analysis helps in optimizing the performance of the worker by changing the design of the product, the job or both.

Biomechanical and physiological measurements of a worker give an objective scale to compare different industrial tasks with respect to strain and fatigue the worker experiences.

## **1.2. MANUAL MATERIAL HANDLING**

Manual material handling (MMH) is the use of human energy to perform tasks that involve lifting, lowering, carrying, pushing, pulling and holding activities. A worker subjected to heavy MMH activities, experiences forces from the activity performed and also forces generated within the body. As a result the worker develops musculoskeletal disorders. There are six important categories of MMH risk factors from industrial jobs [16]:

- 1) Forceful Exertions
- 2) Awkward work posture
- 3) Repetitive motions
- 4) Localized contact stresses
- 5) Whole body or segmental vibrations
- 6) Temperature extremes

Repeated exposure to one or more of the above said risk factors lead to fatigue and discomfort. Prolonged exposure results in musculoskeletal disorders such as injuries to the back, hand, shoulders, etc.

A brief explanation of each type of MMH activity that is commonly performed is given below:

1) Lifting: Lifting involves raising an object from a lower level (floor, platform, etc) to a higher level (Table, shelf, etc). The range of lift can be from the ground to the maximum height you can reach with your hands. The National Institute for Occupational Safety and Health (NIOSH) in 1981 developed a lifting equation to estimate the recommended weight limit of a person. This equation was developed to prevent or reduce work-related low back pain and disability. It was later revised in 1993 [17]. The NIOSH lifting equation takes into account six different variables in defining a recommended weight limit (RWL) for lifting and lowering loads.

“ The RWL is defined for a specific set of task conditions as the weight of the load that nearly all healthy workers (free of adverse health conditions that increases risk of musculoskeletal injury) could perform over a substantial period of time (e.g. up to 8 hours) without developing an increased risk of low back pain or other musculoskeletal injury.”

RWL is defined in terms of the related risk factors, including the horizontal location (HM), vertical location (VM), vertical travel distance (DM), asymmetry angle (AM), frequency of lift (FM) and coupling (CM). The multipliers are defined using standard tables provided by NOISH [4].

Thus  $RWL = LC \times HM \times VM \times DM \times AM \times FM \times CM$

Load Constant (LC) refers to the maximum weight value for standard lifting location. The Lifting index (LI) is defined as “A term that provides a relative estimate of the level of physical stress associated with a particular manual lifting task.”

$LI = \text{LOADWEIGHT} / \text{RECOMMENDED WEIGHT LIMIT}$

The lifting equation is used extensively to estimate the safe lifting index for various manual material lifting tasks. The factors to be considered for lifting tasks are position of load, body posture while lifting, height to be lifted, frequency of lift and object characteristics. Lowering is similar to lifting and is the exact opposite of it.

2) Carrying: The carrying tasks depend on various conditions including frequency, traction between foot and floor, object characteristics and carrying distance. It was found that with an increase in frequency, carrying distance increases energy expenditure levels [18].

3) Pushing and Pulling: Pushing or pulling involves application of force to move an object. Factors influencing pushing and pulling are handle locations, one hand versus two hand force application, body posture, traction, muscle strength, gender, forces acting on the body.

A measure of the strain and fatigue a worker encounters during a task is necessary to analyze and modify tasks. One such measure is prediction of energy expenditure by a worker while performing a job.

### **1.3. ENERGY EXPENDITURE PREDICTION**

While performing repetitive tasks such as lifting, lowering, carrying, etc, a worker experiences large muscle contractions i.e. physiological changes take place within the body. The measurement of these changes provides a level of stress on the worker. The worker endurance is primarily limited by the capacity of the oxygen transporting and utilization systems, in other words maximum aerobic power [3]. By relating the energy expended in a task to the aerobic power of the individual for endurance effort, an



objective assessment can be made of the work capacity of the worker carrying out a task without undue fatigue [3]. The energy expenditure study can become a useful tool for designing of tasks and jobs ergonomically. An estimate of the energy expended directly gives a measure of the strain the worker experiences while performing a task. For a product that has to be designed ergonomically, energy expenditure rate prediction of the worker can be used to arrive at the best posture position, comfort level, lifting and lowering heights, etc.

Snook and Irvine [19] recommended 33% of the maximum aerobic power of a normal healthy person as the maximum energy expenditure rate that should be expended for an eight-hour work day. 16 Kcal/min is taken as the maximum aerobic power of a normal healthy young male for a highly dynamic job [20]. Chaffin [20] stated that for an eight hour work period, a physical work capacity limit of 5.2 Kcal/min is recommended. This is based on thirty-three percent of 16 Kcal/min which is taken as the maximum aerobic power of an average healthy young male.

At present there are three most commonly used methods for determining the metabolic rates [3].

Measurement of oxygen consumption on the job: It is the measurement of oxygen utilization on the job. It become difficult to measure the consumption on the job as there is interference with the measuring equipment and work methods.

Macro-Studies: Macro-studies make use of table values to predict the metabolic energy expended. Table values only give a rough estimate of the energy. Errors can be made if the tasks are overly simplified.

Micro-Studies: Micro-studies uses regression analysis and analysis of variance to estimate the magnitude of metabolic energy expended by a person. It provides a relationship between one or more physical parameters of the task and the energy expenditure rates. All types of tasks are not considered in this case. It is limited to walking, carrying and lifting.

The above mentioned methods are all useful in predicting the metabolic energy rate but are not accurate enough to be used for all types of tasks and there was a need to come up with a better model to predict the metabolic energy expenditure rate.

Any physiological fatigue criteria cannot be used unless it is converted to useful design parameters such as frequencies, weights, etc. A simple but powerful model was given by Garg [3] to estimate the metabolic energy expenditure rates based on physical descriptors of a job and the worker. The model is based on the assumption that a job can be divided into simple elements and the job's energy expenditure rates can be predicted by knowing the energy expenditure rates of the simple tasks. Simple factors such as body weight, gender and time to perform a task element is used to calculate the energy expenditure for a task element. The summation of all the energy expenditures rates of the task elements and the energy required to maintain the posture gives the average metabolic energy expenditure for the job. This can be seen in figure 1.1 [15].

$$E_{\text{job}} = E_{\text{basal}} + S(E_{\text{taskj}} / T_{\text{taskj}})$$

where:

$E_{\text{job}}$  = average energy expenditure rate of the job (Kcal/min)

$E_{\text{basal}}$  = metabolic energy expenditure rate necessary to maintain basal metabolism and posture (Kcal/min)

$E_{\text{taskj}}$  = net metabolic energy expenditure of the jth task in steady state (Kcal)

$T_{\text{taskj}}$  = time duration of the jth task (min.)

Figure 1.1: Equation for Energy Expenditure Rate Prediction

This is the theory behind the software Energy Expenditure Prediction Program™ (EEPP). Equations for predicting the energy expenditure for the task elements are obtained from least square regression analysis. For a complete detailed explanation please refer (Garg [3]).

## **2. PROJECT DESCRIPTION**

### **2.1. PROJECT OBJECTIVE**

The aim of this research project was to redesign and fabricate prototypes of mechanical assists for the Medium Girder Bridge (MGB) to reduce strain and fatigue for the soldiers. The project also involved study of Energy Expenditure rates using University of Michigan's Energy Expenditure Prediction Program™ (EEPP). EEPP was extensively used to estimate the energy expenditure rates of a soldier while using the current assists and also for the redesigned new assists. The results from both were compared for better understanding the human factors and validating the redesigned assists as required.

The main challenge was to study the bridge build process with the current assists and using that to approximate the bridge build process for redesigned bridge assists. The data for the current assists was obtained from a field test. As there was no field test conducted for the new designed assists, necessary approximations and assumptions were made to estimate the parameters required for the EEPP analysis. Designing the bridge building process with the new assists involved making use of the redesigned hand tools, redesigned hand truck and the redesigned crane system.

To understand the scope of the project, basic knowledge of MGB, its components, tools used for bridge construction and bridge building sequence is essential. All these will be discussed with some detail in this chapter.

## 2.2. PROJECT BACKGROUND

The United States of America Army soldiers face strenuous manual material handling (MMH) during construction of bridges. In particular the quick to build medium girder bridge (MGB).

**2.2.1. Medium Girder Bridge (MGB):** The Medium Girder Bridge is a good example of high quality engineering that has stood the test of time. It has been in operation since 1971 and more than 500 MGB have been built for different customers worldwide [5]. Some of the key highlights of MGBs are light weight, quick to build, easy to transport, easy to deploy, easy maintenance and cost effectiveness. It has been used in many relief situations and emergencies. The MGB is a modular two girder, deck bridge. The parts are fabricated using specially developed zinc, magnesium and aluminum alloy (DGFVE 232A). The girders provide a 4.0m (13.1 ft) gap where a deck is used as the roadway. The MGB has three different configurations as shown in figure 2.1 [6]

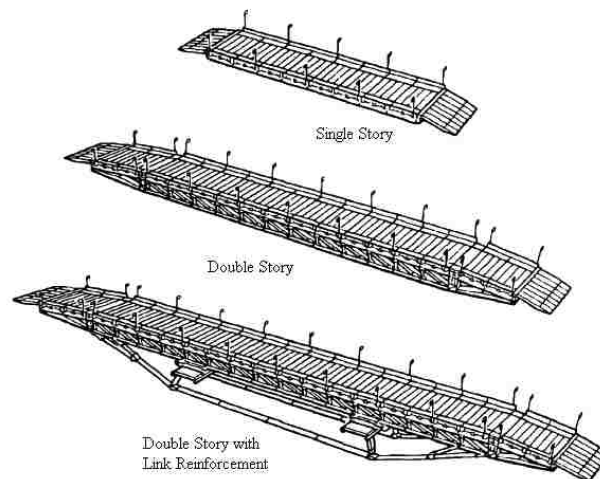

Figure 2.1: Configurations of MGB

1) Single storey: The single storey is build by using top panels that are pinned together and form the two girders of the bridge. The girders are connected to a bankseat beam. They are usually used for short spans of up to 5 bays. They are used for lighter loads.

The single storey bridges are used for up to 9.7 m (32 ft) and require 9 to 16 soldiers to build depending on the length. The configuration of a single storey bridge is shown in figure 2.2 [5].

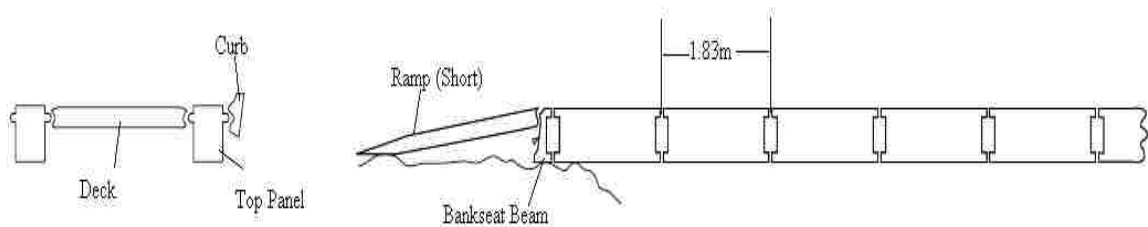

Figure 2.2: Single Storey Bridge Configuration

2) Double storey: The double storey has all the parts of the single storey. The top panel is pinned by a bottom panel at the bottom. The top panels and bottom panels together form the two storey of the bridge. Bridge ends have end taper panels and junction panels that form the sloping end of the bridge. The double storey bridges are used when the bridging distance is up to 31 m (102 ft). All double storey bridges require 24 soldiers to build. The configuration of a double storey bridge is shown in figure 2.3 [5].

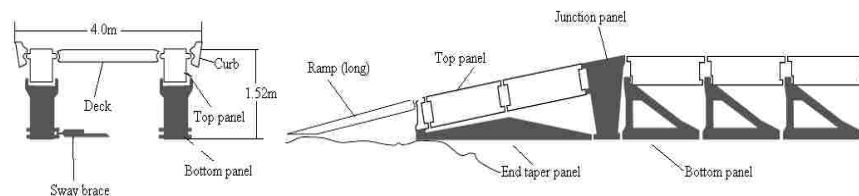

Figure 2.3: Double Storey Bridge Configuration

3) Double storey with link reinforcement: Special link reinforcement account for further length increase to up to 45.7 m (150 ft) These bridges require 24 soldiers and another 9 soldiers for the assembly of the link reinforcement.

**2.2.2. Major MGB Components:** The major bridge components for construction of a MGB and for the design of the assists are shown in figure 2.4 [5].

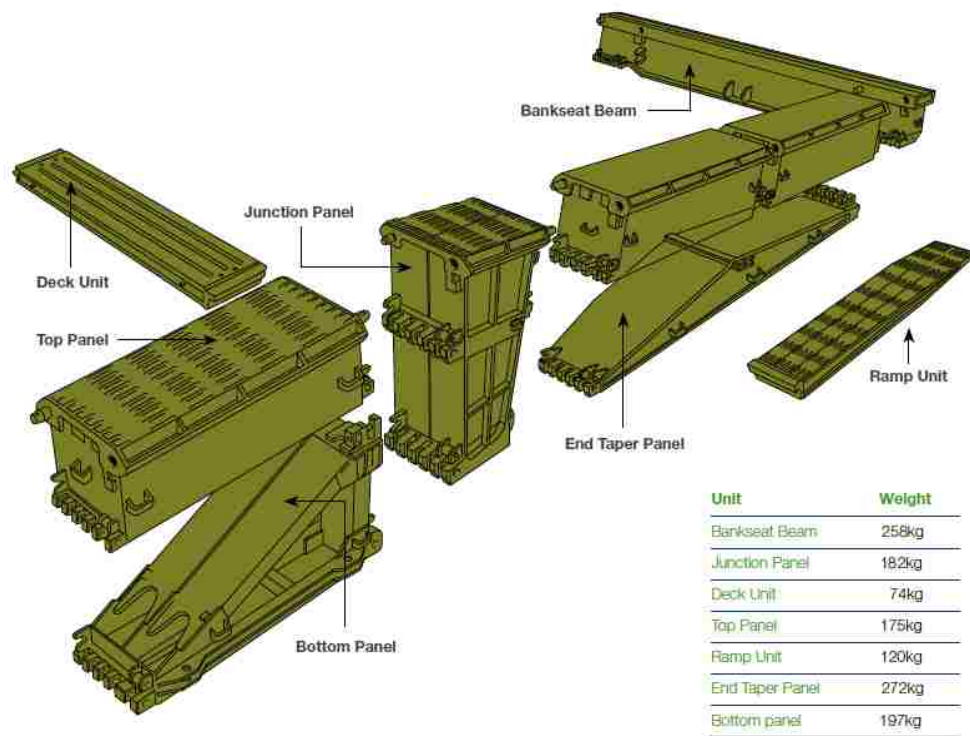

Figure 2.4: Major Components of MGB and Their Weights

1) Bankseat Beam: It is used as a support structure for the girders and is used at both ends of the bridge. It is connected to the top panels which form the bridge girders or to the end taper panel. It is carried by six soldiers.

2) Top Panel: Top panel forms the girders of the bridge. It is attached to a bankseat beam, junction panel or to another top panel. It is carried by four soldiers using the carry bar. The carry bar is located on to the carry loops provided on both sides of the top panel.

Each side has two carry loops. The top panel also supports the bottom panel for the double storey bridge.

3) Bottom Panel: It forms the brace for the bridge girders or it is also called the second girder. It is carried using a carry bar. Bottom panel also has two carry loops on each side. It requires four soldiers to carry.

4) End Taper Panel: The end taper panel is the support structure between the junction panel and the bankseat beam. It provides the bearing surface to support the bridge. It is used in double storey MGB. It is the heaviest part of the MGB. It requires six soldiers to carry and it is carried using a carry bar.

5) Junction Panel: Junction panel is used to connect the end of the bridge to the level roadway of the bridge. It is connected to top panels. It is carried by four soldiers and is carried using carry bars.

6) Deck: Deck form the roadway. They are placed between the main girders to complete the roadway. They are carried by two soldiers and are carried using the carry handle. It is also used as a lever to ease pinning or unpinning of the bankseat beam.

7) Ramp: The ramp unit can be short or long depending upon the requirement. It is used at each end of the bridge to form the access for vehicles to enter or exit the roadway of the bridge. Short ramps are used in the case of single story MGB. It requires four of six soldiers to carry and is carried using a carry handle.

The weights and the major dimensions of the nine major MGB parts are given in table 2.1[6]. The seven major parts of the MGB along with the roller beam and the heavy launching nose used during launching of the bridge will be used for energy expenditure prediction analysis later on.



Table 2.1: MGB Major Component Dimensions

Component	Weight kg (lbs)	Length m (ft)	Width m (ft)	Height m (ft)
Bankseat Beam	258.5 (570)	3.96 (13)	0.38 (1.25)	0.54 (1.8)
Top Panel	174.6 (385)	1.82 (6)	0.53 (1.75)	0.54 (1.8)
Bottom Panel	197.2 (435)	1.98 (6.5)	0.53 (1.75)	1.06 (3.5)
Junction Panel	216.8 (478)	0.91 (3)	0.53 (1.75)	1.37 (4.5)
End Taper Panel	272.1 (600)	3.96 (13)	0.60 (2)	0.45 (1.5)
Deck	74.0 (163)	2.74 (9)	0.45 (1.5)	0.15 (0.5)
Long Ramp	181.4 (400)	4.26 (14)	0.60 (2)	0.22 (0.75)
Heavy Launching Nose	175.0 (386)	2.74 (9)	0.53 (1.75)	0.54 (1.8)
Roller Beam	145.1 (320)	4.26 (14)	0.22 (0.75)	0.30 (1)

**2.2.3. MGB Carry Tools:** All the bridge parts are lifted manually, carried and transported using two main carrying tools, the carry bar and the carry handle. Figure 2.5 shows the carrying tools that are used for the MGB construction [6].



Figure 2.5: Carrying Tools for MGB

The carry bar is used on five of the major MGB parts and allows a two-handed grip. The carry handle is used to lift and move mainly the deck and the ramp and allows a one-hand grip. Due to repetitive work such as lifting parts off the pallet and carrying them to the construction site, the soldiers face with very high strain and fatigue levels, as the carry tools requires the soldiers to squat and bend often while lifting and assembling the bridge parts. The redesigned tools will address this issue and are ergonomically designed to lift and carry the bridge parts with ease.

The bridge components are stored and transported on standard pallets. They are carried on a truck or a trailer. There are different types of pallets, depending on the type of part on it. Figure 2.6 shows two different pallets on which bridge parts are transported.



Figure 2.6: Pallet Loads

The pallets are loaded using cranes and transported by trucks or trailers. The bridges are constructed for training, routine exercises and during combat. After placing the pallets on the ground, the parts have to be manually lifted from the pallet and carried to the construction site which is over 15.2 m (50 ft) away. The soldiers experience heavy strain and fatigue doing the tasks manually. Hence the need of redesign of the carry tools and also the need of a hand truck and a crane system to transport and assemble bridge parts.

**2.2.4. MGB Building Sequence:** To design tools for the bridge construction process, information on the bridge building sequence is vital. Studying the sequence of the bridge build allowed design of the tools to be more effective. The energy expenditure analysis performed for the bridge construction is based on the bridge building sequence and every step a soldier takes while working with the bridge parts is noted and tracked. As the research mainly involves the analysis of a two-story bridge, all information in this

thesis is related to a two-story bridge without link reinforcement. The bridge building process was studied using videos and MGB construction exercises.

The steps involved in the bridge building are:

- 1) Determining the number of bays required: Firstly the number of bays required and the configuration of the bridge required are determined. The length of the gap helps in determining the number of bays required. The pallets are placed as close as possible to the construction site.
- 2) Assembly of roller beam and end of bridge: After determining the number of bays required, the roller beam is carried from the pallet to the construction site. It is aligned and assembled with the adjustable support. Care is taken to ensure the roller beam is level with respect to the ground. The end of bridge which is the bankseat beam, end taper panel, junction panel and the first two bays of the bridge are constructed after the assembly of the roller beam. All the bridge parts are carried manually from the pallet to the construction site. The parts are lifted to the desired height manually and positioned for assembly.
- 3) Assembly of third and subsequent bays: After the assembly of the first two bays, the main roadway of the bridge is constructed. This mainly consists of top panels and bottom panels. The parts are carried manually from the pallet to the construction site. The parts are lifted to the desired height manually and positioned for assembly.
- 4) Assemble launching nose: After assembling the third or fourth bay, the launching nose along with landing roller pedestal is assembled. The bridge is boomed to the required height. Similar procedure is followed to assemble remaining bays. A vehicle (Truck) is used to boom bridge. The launching nose is disassembled after the bridge is boomed.

5) Decking and ramps: After the bridge is boomed in place and the far shore crew ensures the lowering of the bridge, the bridge is lowered and decking is done. After decking, ramps are assembled to both ends of the bridge. Finally curbing is done.

### **3. DESIGN METHODOLOGY**

#### **3.1. DESIGN PROCESS**

An attempt was made earlier to modify the current MGB assists. The first redesign of the mechanical assists did a very good job in addressing the major issues of strain and fatigue levels in workers during the bridge build. The tools were ergonomically designed. A field test was performed to test the first redesign of mechanical assists. Several constructive design modifications were needed to improve the use of the designed mechanical assists. Also to validate the redesign, a human factor study which compared the old assists to the new was essential. The redesigned assists have to improve the efficiency of bridge build.

The bridge building tasks were laborious even with the redesigned hand tools. An internet based research was done to study commercially available manual material handling tool such as hand tools, hand trucks and cranes. The mechanical assists design for the MGB parts needed very high customization and the commercial products cannot be used or modified to use.

The field test results were extensively used to assess the design modifications required. Also constructive suggestions from soldiers and engineers of MGB were valuable. The modifications of the mechanical assists required study of the bridge building process. This was done by studying the bridge build on recorded video tapes and also studying MGB operator's manual.

For both the first and the second redesign, standard design procedure was followed. Concept design were created and evaluated to check if all the needs are addressed. After fixing on the concept, the detail design and design for manufacture was

done. Detail design involved 3-D CAD modeling using Pro/Engineer. The models created were parametric. Important dimensions and tolerances with respect to the bridge parts were studied. The first redesign tools [7] were extensively used for the second redesign. The first redesigned parts were analyzed using finite element analysis tool ANSYS and ABAQUS [22]. Before the final prototypes were made, few alpha prototypes were made in the workshop and tested to check for satisfactory functioning. After alpha prototypes the final beta prototypes were fabricated for delivery.

### **3.2. MATERIAL SELECTION**

The material selected for the first redesign was based on couple of important factors. The material should be light in weight and cost effective also they should be made from a similar material as the bridge. The bridge parts are made of a special alloy of Zinc, Magnesium and Aluminum (DGFVE 232A).

Aluminum alloy was the choice for the first and second redesign. The key factors for considering aluminum alloys for designs are low density, good strength to weight ratio, corrosion resistance, ductility, excellent workability, reasonable cost and casting properties.

After researching different aluminum alloys, the material for the tools were fixed to AL 6061-T6. This alloy of aluminum has tensile yield strength of  $2.75 \times 10^8$  Pa (40000psi), 17% elongation at break,  $2698.7 \text{ kg/m}^3$  ( $0.0975 \text{ lb/in}^3$ ) density and costs around \$6 per pound. Although steel has better elongation (around 20-25%), the density of steel is higher (around  $7750.3 \text{ kg/m}^3$  or  $0.28 \text{ lb/in}^3$ ). This increases the weight of the tools and thereby soldiers will experience increase in strain and fatigue while performing

bridge tasks. Moreover steel had a tendency to corrode over time and aluminum has greater corrosion resistance when compared to steel.

### **3.3. DESIGN INPUTS**

The main input for the first and second redesign of assists was the feedback from soldiers and engineers. A survey was conducted during the first redesign to study the concerns and issues the soldiers had with the assists. An ergonomic survey questionnaire was prepared during the first redesign and questions pertaining to the use of the assists, bridge parts and fatigue due to construction were asked. The survey yielded lot of information regarding modifications that was needed for the assists. Also a 3D Static Strength Prediction Program™ (3DSSPP) analysis was performed to study the lifting postures. The analysis revealed bridge components caused injury to L5/S1. Almost all bridge parts exceed the NOISH recommended design limit of 349.2 kg (770 lbs) compression for the L5/S1 disc [8].

The current assists have many discrepancies. Some of them are:

- 1) The hand tools required frequent squat and stoop postures for performing lifting and carrying tasks. This strained the low back of soldiers performing the bridge tasks.
- 2) The roller cart used has a pull handle instead of a push handle. Research has revealed that pushing is better than pulling and that pulling requires larger forces. Also the cart has three wheels and was unstable on uneven terrain. Assembly and disassembly of the bridge parts on the roller cart was cumbersome and was inefficient.

3) A panel erection aid was designed for lifting and assembling top and bottom panels bridge parts. It was found inefficient and slow and required manual intervention. Figure 3.1 shows the roller cart and the panel erection aid used earlier [6].



Figure 3.1: Roller Cart and Panel Erection Aid

Based on the current assists available for the bridge parts and the feedback from soldiers and engineers, a requirement list was prepared for the hand tools, hand truck and the crane system. Some of the characteristics that are required are given below:

1) Hand Tools: The hand tools should require minimum bending to reduce strain on the back. The hand tools should have two-hand grip instead of one. The hand tools should be modular in design to enable easy assembly and disassembly. The hand tools should be light in weight.

2) Hand Truck: The hand truck should be designed for pushing instead of pulling and should have durable wheels to handle different terrains. It should enable a one soldier push. The truck should accommodate all shapes of bridge parts and the parts should be easy to secure.



3) Crane: The crane should be used to lift both top and bottom panels. It should be fast and minimize manual lifting. It should be light in weight and easy to mount and dismount on the bridge parts. It should have variable speed and should be able to secure and release components easily.

## **4. REDESIGN OF MECHANICAL ASSISTS**

The field test results of the first redesign of the mechanical assists showed that some modifications and changes were required for the assists. To improve the efficiency and usability of the assists a redesign of some features of the hand tools, hand truck and the crane was proposed. The first redesign was effective to reduce the musculoskeletal injuries of the hands, arms, shoulders and the back. The design modifications made to the hand tools, hand truck and the crane system are discussed with some detail in this chapter.

### **4.1. HAND TOOL REDESIGN**

The current hand tools are shown in Figure 4.1. The hand tools help soldiers lift the bridge components and carry them to the bridge construction site. The carry bar is used by mounting the carry bar head on the carry bar connection provided on the bridge part which allows a two hand grip. The carry handle mounts onto carry handle holes provided on the bridge part. The carry bar allows a two-hand grip and requires squat and stoop body postures to lift bridge parts from the ground. The carry handle allows a one hand grip and is used to lift the deck and the ramp bridge parts.

The carry bar is used to carry five of the seven important bridge parts. The deck and long ramp are carried using the carry handle. It was proposed to increase the lifting height for both the carry bar and the carry handle to reduce the low back stress on the soldiers. Two-hand grip was found better when compared to one-hand grip. It was proposed to provide two-hand grip for the carry handle.



Figure 4.1: Current Carrying Tools

Lot of studies has been done with respect to design of a handle for a hand tool. A standard set of principles was required for the design of hand and wrist tasks. NOISH came up with a set of design guidelines for hand and wrist jobs [9]. The design considerations for hand and wrist tasks are given below:

- 1) To avoid static muscle loading, reduce both the weight and size of the tool. Do not raise or extend elbows when working with heavy tools. Provide counter-balanced support devices for larger, heavier tools.
- 2) Avoid stress on soft tissues. Stress concentrations result from poorly designed tools that exert pressure on the palms or fingers.
- 3) Reduce grip force requirements. The greater the effort to maintain control of a hand tool, the higher the potential for injury. A compressible gripping surface rather than hard plastic may alleviate this problem.

- 4) Whenever possible, select tools that use a full-hand power grip rather than a precision finger grip.
- 5) Maintain optimal grip span. The recommended handle diameters for circular-handle tools such as screwdrivers are 3cm (1.18 in) to 5 cm (1.96 in) when a power grip is required and 0.75 cm (0.29 in) to 1.5 cm (0.59 in) when a precision finger grip is needed.
- 6) Avoid sharp edges and pinch points. Select tools that will not cut or pinch the hands even when gloves are not worn.
- 7) Isolate hands from heat, cold, and vibration. Heat and cold can cause loss of manual dexterity and increased grip strength requirements. Excessive vibration can cause reduced blood circulation in the hands causing a painful condition known as white-finger syndrome.

This design guideline was used for both the first and the new redesign of the hand tools for MGB. The redesigned hand tools have an inclined portion and a straight portion. The angle on the inclined portion is 70 degrees. The straight portion of the carry bar and the carry handle was kept horizontal for easy lifts and gripping.

**4.1.1. First Redesign:** The first redesign of the hand tools provided two-hand grip for both the carry bar and carry handle. The redesign raised the lift starting height of the carry bar by 0.35 m (14 in) and by 0.15 m (6 in) for the carry handle. This enabled to reduce strain on the soldier's back while performing repetitive lifting and carrying tasks. Figure 4.2 shows the first redesign of the current hand tools. A plug was introduced in the carry bar head to prevent the misalignment of the bar head in the carry bar connection on the bridge parts. A support rod was introduced in the carry handle head to prevent bending of the hooks during operation.



Figure 4.2: First Redesign of Hand Tools

**4.1.2. Design Modifications Required for the Hand Tools:** The first redesign of the hand tools was very effective and performed well during the field test. The performance of the soldiers was improved with the new hand tools. The redesigned hand tools significantly lowered the lower back disc compression. The lifting index for the redesigned hand tools was reduced by 16% and the L5/S1 disc compression was reduced by 36% [7]. Some design modifications were essential for effective use of the hand tools.

They are:

- 1) The profile of the carry bar head had to be matched with the profile of the carry bar connection provided on the bridge parts in such a way that the vertical portion of the carry bar head maintains complete positive fit with the carry bar connection provided on the bridge parts. A plug was introduced to account for the misalignment. The plug did a temporary design modification, but for improved efficiency, a profile change was required.
- 2) The carry bar was made modular in the first redesign. The straight portion of the carry bar can be removed and attached for easy storage and transportation. The straight portion

of the carry bar required a carry bar head to enable soldiers to detach the straight portion from the inclined portion and use it for certain manipulations where the inclined portion was inconvenient.

3) With the inclusion of a carry bar head on the straight portion of the carry bar, the quick pin hole provided on the straight portion and inclined portion to enable assembly of both, had to be changed to a slot. The slot will enable half rotation (180 degrees) of the straight portion. This is required for fast and easy assembly and disassembly of the carry bar and to ensure better convenience of use for the soldiers.

4) The hooks provided on the carry handle to fit into the carry handle holes on the deck and ramps bent during repeated operation. To prevent bending of the carry handle hooks, the lower part of the inclined portion of the carry handle will be made of steel and assembled to the aluminum part. This will enable robust and rigid design of the hooks on the carry handle. The carry handle design will be kept modular and similar to the carry bar. It will provide a two-hand grip instead of a one-hand grip.

**4.1.3. Redesign of the Hand Tools:** The overall dimensions of the hand tools for the redesign were kept similar to the first redesign. The hand tools were modular in design and all the issues faced with the first redesign were addressed and the hand tools were designed for better ergonomic standards and usability.

**4.1.4. Carry Bar Redesign:** The profile of the carry bar was matched to the profile of the bridge part carry bar connection in a way that the vertical portion of the carry bar head made complete contact with the carry bar connection on the bridge part. This ensures better grip and slipping of the carry bar from the bridge part is prevented. Figure 4.3 shows the new design of the carry bar.



Figure 4.3: Redesigned Carry Bar

The straight portion of the carry bar was provided with a carry bar head for manipulations that are faster and easier with a straight tool rather than an inclined tool. The hole provided for the quick pin was slotted to enable quick 180 degrees rotation of the straight portion. This helped in faster assembly and disassembly and better working efficiency for the soldiers. Figure 4.4 shows the carry bar prototype manufactured at the Mechanical Department workshop.



Figure 4.4: Redesigned Carry Bar Prototype

All the issues faced with the first redesign were addressed. The carry bar with modifications had to be tested for performance and usability.

**4.1.5. Prototype Testing of Carry Bar:** Although the carry bar prototypes were redesigned and fabricated as per requirement, there was a welding failure that was noticed during testing. Figure 4.5 shows the welding failure observed. The welding failure was observed during horizontal loading of the carry bar. This type of failure can be hazardous and very dangerous for soldiers. To ensure safety of the soldiers, each carry bar had to be proof loaded and checked for failures. Each carry bar was loaded to a minimum of 90.7 kg (200 lb). Each carry bar was repeatedly loaded and unloaded at this load for several lift and lower cycles and was checked for failures before delivery.



Figure 4.5: Carry Bar Prototype Failure

**4.1.6. Carry Handle Redesign:** As the hooks of the carry handle was made of aluminum for the first redesign, bending of the hooks was observed during lifting. A support rod was provided to address this issue in the first redesign, but the bending was



not arrested. This was taken care by changing the material to mild steel for the carry handle head. The hooks were made of mild steel and hence were stronger to withstand bending. Figure 4.6 shows the redesigned carry handle. The dark colored area in the figure is the portion of the carry handle made of mild steel. Welding of steel to aluminum is not possible and this issue was addressed by drilling two holes on the steel portion and using small filler rods in the drilled holes. A solid aluminum rod equal to the inner diameter of the tube was welded to the aluminum part and fitted into the steel tube. Through holes were drilled on the steel tube and the aluminum rod. Small filler rods were inserted into the drilled holes. The filler rods were made of steel and was welded to the steel portion of the carry handle.



Figure 4.6: Redesigned Carry Handle

The weight of the carry handle was 4.17 kg (9.2 lb) after the second redesign. Although the steel portion provided increased the weight of the carry handle, the carry handles were more durable and efficient. The carry handles are used to lift the deck and

the ramp. They experience a maximum load of 45.3 kg (100 lb). The increase in weight of the carry handle due to the addition of the steel part did not affect the performance to a great level. Figure 4.7 shows the prototype of the carry handle fabricated in the Mechanical Department workshop. A template was made to bend the steel rods to the required shape. The testing of the carry handle yielded positive results. The carry handle hooks did not bend during operation. The performance was consistent and improved. The new carry handle eliminated the need of a support rod that was provided to take care of the bending during lifting in the earlier design.



Figure 4.7: Fabricated Prototype of Carry Handle

**4.1.7. Prototype Testing of Carry Handle:** The redesigned carry handle was tested for performance. The carry handle interfaced acceptably to the deck panel. The straight section of the handle was elevated above horizontal when engaged to the deck panel, which was not ideal but did not affect the performance. The new hand tools reduced the energy expenditure rate of the soldiers to a considerable level. The energy expenditure rates are discussed with detail in chapter 5.

**4.1.8. Bill of Material:** The bill of material for a single carry bar and carry handle is shown in table 4.1.

Table 4.1: Bill of Material of Carry Bar and Carry Handle

BILL OF MATERIAL								
Sl No	Description	Material	Dimensions mm (in)				Quantity	Price(\$)
			Length	Base	Height	Thickness		
1	Drawn Tube	AL 6061-T6	1066.8 (42)	31.75 (1.25) i.d	44.45(1.75) o.d	6.35 (0.25)	1	113.05
2	Square Bar	AL 6061-T6	203.2 (8)	50.8 (2)	76.2 (3)		1	14.56
3	Round Bar	AL 6061-T6	152.4 (6)	31.75 (1.25) o.d			1	12.705
4	Pin						1	6.2
Total approximate material cost for one carry bar								146.515
BILL OF MATERIAL								
Sl No	Description	Material	Dimensions mm (in)				Quantity	Price(\$)
			Length	Base	Height	Thickness		
1	Drawn Tube	AL 6061-T6	914.4 (36)	31.75 (1.25) i.d	44.45(1.75) o.d	6.35 (0.25)	1	96.9
2	Round Bar	AL 6061-T6	203.2 (8)	31.75 (1.25) o.d			1	15.246
3	Drawn Tube	CS A51315	203.2 (8)	31.75 (1.25) i.d	44.45(1.75) o.d		1	5.55
4	Round Bar	CR 1018	457.2 (18)	31.75 (1.25) o.d			1	1.98
5	Flat Bar	CR 1018	152.4 (6)	12.7 (0.5)	50.8 (2)		1	0.792
6	Pin						1	6.2
Total approximate material cost for one carry handle								126.668

## 4.2. HAND TRUCK DESIGN

Several different types of carts were used with the current hand tools to transport bridge parts from the pallet to the construction site. The roller cart shown earlier is an example of a push cart that was used earlier. The roller cart was a pull cart instead of a push cart. It was not ergonomically designed. Loading and unloading parts was cumbersome. The carrying distance from pallet to the construction site is usually greater than 18.28 m (60 ft). The soldiers experience high fatigue and strain levels while transporting the parts manually. A push cart system to help in transporting the bridge parts was suggested during the survey with the soldiers. The main concern for the cart was the rolling on uneven surfaces. The cart should be designed to push and transport bridge parts on any terrain. The cart should be ergonomically designed and should be pushed with minimum force. It should accommodate all shapes of bridge components. It should also allow easy and fast securing and release of bridge parts. The cart should also be designed for low cost and for easy manufacture.

Research shows that pushing is preferred to pulling for many reasons. While pulling a cart in the direction of travel, the person has to stretch his/her arms behind the body, placing the shoulder and back in an awkward posture. This increases the chance of injury to the body. And also pulling backwards does not give the person sight of the path of travel. This is again dangerous and should be avoided.

**4.2.1. Factors Affecting Pushing and Pulling** There are a number of important factors that affect the force that a person has to apply to push or pull a cart. They are listed in figure 4.8 [10].



Figure 4.8: Factors Affecting Pushing/Pulling

While designing the hand truck the first time, all the above factors were considered.

**4.2.2. First Design of Hand Truck:** Several concepts were developed using the concept generator and brainstorming [7]. After several design concepts, the concept with

maximum rating was selected as the final design. The figure 4.9 shows the final design of the hand truck. The chassis, handle subsystem and the wheels are seen.



Figure 4.9: First Design of Hand Truck

The final design was 2.8 m (9.5 ft) in length and weighed 58.9 kg (130 lb). It consisted of three subsystems: The chassis, the handle and the wheels. The chassis was made as an adjustable length chassis. The front member could be slid through loops in the rear chassis and it was held in position with a quick release pin. The folded length of the truck was 2.28 m (7.5 ft). The rear chassis members were made of 0.05 m x 0.10 m x 0.003 m thick (2 in x 4 in x 0.125 in) rectangular aluminum tube. The front chassis was made of 0.03 m x 0.07 m x 0.003 m thick (1.5 in x 3 in x 0.125 in) rectangular aluminum tube and the support members for both were made of 0.03 m x 0.05 m x 0.003 m thick (1.5 in x 2 in x 0.125 in) rectangular aluminum tube. Carry loops were provided on the chassis to secure the bridge parts.

The handle subsystem was made of a circular tubular grip. The tube size was 0.04 m (1.75 in) for effective gripping. Handle height is very important for effective pushing. The average elbow height for U.S. Army men is 1.10 m (43.37 in) [11]. It is

recommended that handle height should be close to this value. Average value of 1.06 m (42 in) from the ground is taken for handle height.

The final design of the hand truck made use of Roleez® wheels for the alpha prototypes. The wheel assembly consisted of six caster configuration. The center two wheels were rigid. Four swivel casters were used at the front and near the handle. This offered good maneuverability. The wheel diameter, spacing between wheels and the profile of the wheel are important factors for easy and effective handling of the hand truck.

The Roleez® wheels are special purpose balloon wheels. They are made of thermoplastic polyurethane. The required load capacity of a castor is 113.3 kg (250 lb) which includes the weight of the truck and the load. The castor failed during testing as shown in figure 4.10. The castor was made of glass reinforced nylon.



Figure 4.10: Hand Truck Castor Failure

Testing of the material of the castor revealed that it was a brittle material. It was then proposed to use metal castor wheels. Caterpillar castor wheels (Source

[www.castercity.com](http://www.castercity.com)) were used. The tire for this wheel was made of polyurethane foam and was solid. It eliminated the need of varying tire air pressure. Figure 4.11 shows the hand truck with the new set of wheels. Design analysis was carried out for the hand truck [7].



Figure 4.11: Hand truck with Caterpillar Wheels

**4.2.3. Modifications Required on the Hand Truck:** The hand truck designed showed good results during field tests. The average initial pushing force was 22.6 kg (50 lb) and the average sustained force was 15.8 kg (35 lb), with a maximum load of 272 kg (600 lb) on the truck. The hand truck was tested on different terrains such as asphalt, gravel and sand. Although the performance of the hand truck was good and the forces applied to push the cart was well within the limit, some modifications were required to make the design more robust and sound. The changes that are required are listed below:

- 1) Rugged wheel assembly was needed. The wheel castor is the weak component in the wheel assembly as it experiences three different forces the inertial forces, forces due to physical interference and the frictional forces. The turning of the castor frequently during

operation on rough terrain such as gravel or sand increases the chance of failure. Hence new set of wheels were proposed for the redesign.

2) The sliding front chassis was found ineffective during field tests and had to be removed. The chassis for the redesign will consist of one single unit instead of a fixed unit and a sliding unit. The lengths of all bridge components averaged between 2.7 m (9ft) to 2.8 m (9.5 ft). Apart from the Junction panel all other parts had a length of more than 1.8 m (6 ft). The top fender plate for the first design had cutouts and logos of the Army, UMR and the MANSCEN logo. This reduced the weight of the hand truck, but was not necessary and did not affect the performance of the cart to a very great extent. It increased the cost of manufacturing. The redesign will have a fender plate with no slots or logos.

**4.2.4. Redesign of the Hand Truck:** The modifications required from the first design were made in the redesign. The hand was designed for rugged wheels and chassis.

1) Wheel Sub system: The wheel sub system is the most critical component of the hand truck. The first design had issues with the wheel sub system. As the truck will be handled on different terrains, a rugged and strong wheel sub system was essential. Several wheel assemblies were studied on the internet and research was done to find the best wheel sub system in market for the hand truck.

Study and literature research resulted in narrowing down to Hustler® Super Z 25/60” series lawn mover front wheel subsystem. The Wheel sub assembly had the tire configuration diameter of 0.33 m (13 in) and width of 0.16 m (6.6 in). Figure 4.12 shows the Hustler® wheel sub system.





Figure 4.12: Hustler® Wheel Sub System

The Hustler® wheel sub system has castor made of steel and the tires are wide enough to handle loads that exceed 272 kg (600lb). The wheel sub system is comparatively heavier when compared to the previous design. The weight of the hand truck system increased to 118 kg (260 lb) compared to the 58.9 kg (130 lb) of the earlier design with float wheels. The castor is made of mild steel and is 0.012 m (0.5 in) thick. The wheel sub system assembly consists of the bearing assembly for the wheel rotation, the castor and the tires.

The four wheels, two at the front of the truck and two near the handle are free to swivel and aid in direction control of the hand truck. The center two wheels are swivel free. The swiveling of the center wheels are arrested by welding a mild steel strip to the castor and the chassis, making use of a mild steel sheet as shown in figure 4.13.



Figure 4.13: Center Wheels of Redesigned Hand Truck

As the castor was purchased and not fabricated in house, changes were not made to the center wheel sub assembly. Slots and cutouts were made in the chassis support cross members and the fender sheet to accommodate the bearing assembly of the wheel subsystem. The square support cross members were cut and machined to accommodate the wheel sub system. The circular tubing used for the bearing assembly of the wheels was welded to the support cross members under the fender plate.

The hand truck was modeled using a CAD package as shown in figure 4.14. The figure shows the isometric front and bottom views of the hand truck. The front view of the hand truck shows the cutouts or slots made on the fender plate to accommodate the wheel bearing assembly. 2-D drawings generated from the software was used during prototype manufacture of the hand truck.

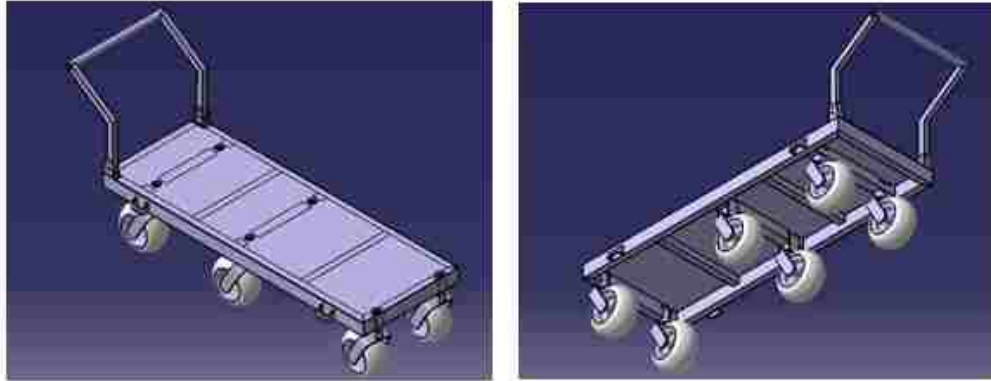

Figure 4.14: CAD Model of Hand Truck

The performance of the cart with the new set of wheels will be discussed in detail in section 4.2.4.

2) Chassis: The chassis was changed from a sliding two piece chassis to a single chassis made of 0.05 m x 0.10 m x 0.003 m thick (2 in x 4 in x 0.125 in) rectangular aluminum tube. Cross members are made of square tube of 0.05 m (2 in) and 0.003 m (0.125 in) thick and 0.07 m (3 in) and 0.003 m (0.125 in) thick square aluminum tube. They are alternated with each other. Figure 4.14 shows the chassis members.

3) Handle sub system: Similar handle sub system was used for the second redesign. The handle sub system performed very well and did not require any design modifications.

Figure 4.15 shows the important chassis dimensions of the hand truck and also the wheel mounting positions in millimeters. It is seen from the figure that the handle dimensions are maintained similar to the first design of the hand truck. The comfortable handle was found to be 1.09 m (42 in) from the floor. The wheels are spaced in such a way that they enable free 360 degrees swivel of the front and the rear wheels. The center two wheels are arrested for swivel. The total length of the hand truck assembly is 2.19 m (7.1 ft).

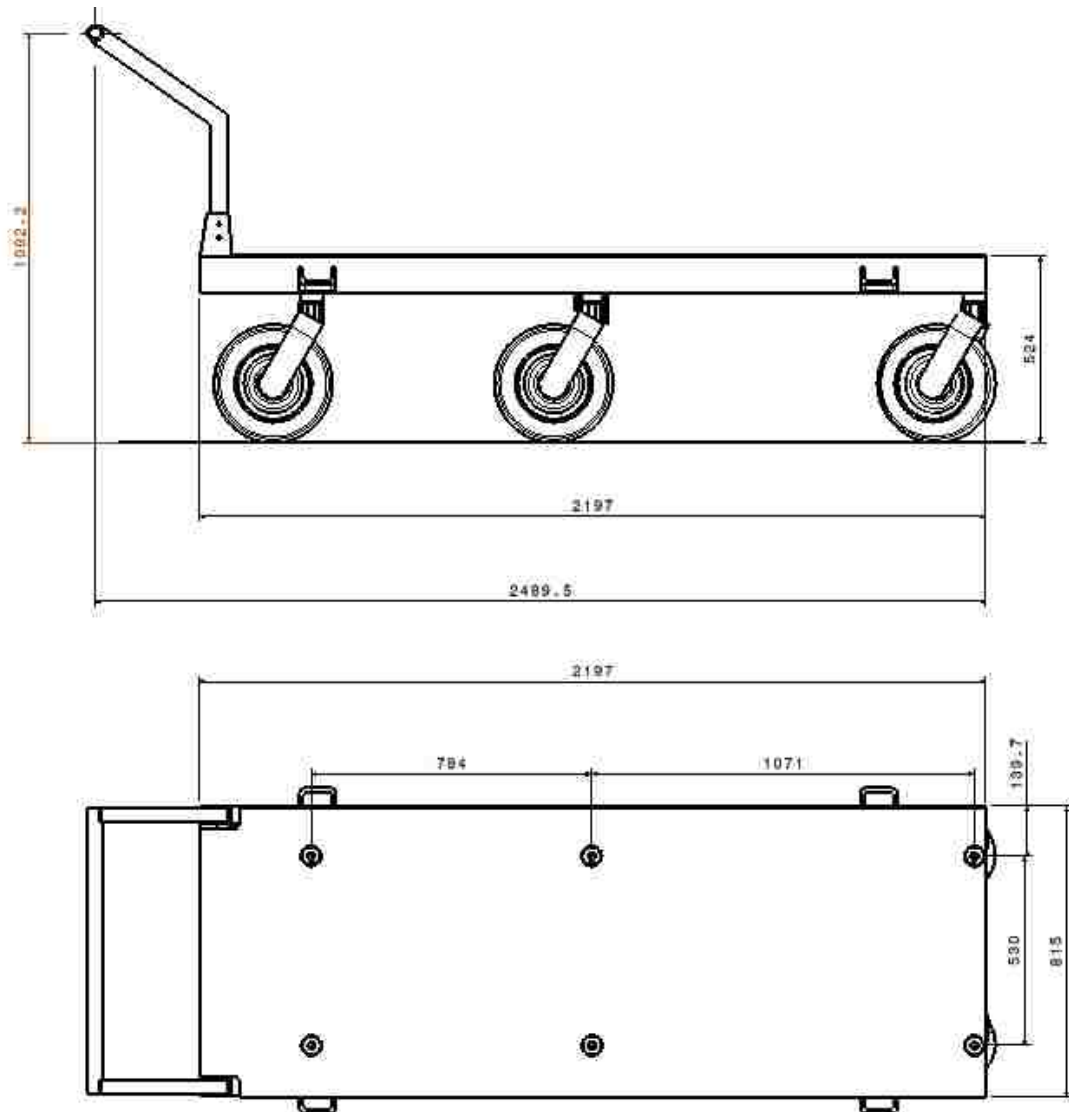

Figure 4.15: Hand Truck Dimensions

**4.2.5. Final Prototype:** The major fabrication of the hand truck was done in the mechanical department workshop and the CEST workshop. Simple machines such as a band saw, lathe, and a drilling machine were used. Figure 4.16 shows the final prototype of the hand truck.



Figure 4.16: Final Prototype of Hand Truck

**4.2.6. Bill of Material:** The bill of material with approximate cost analysis for a single hand truck is shown in table 4.2. All dimensions are in United States customary units.

Table 4.2: Bill of Material of Hand Truck with Cost Analysis

BILL OF MATERIAL										
Sl No	Description	Material	Dimensions mm (in)				Quantity	Price each (\$)	Price(\$)	Hand truck Component
			Length	Base	Height	Thickness				
1	Bare Rectangular Tube	AL 6063-T52	2235.2 (88)	50.8 (2)	101.6 (4)	3.175 (0.125)	2	98.56	197.12	Chassis side beams
2	Bare Rectangular Tube	AL 6063-T53	812.8 (32)	50.8 (2)	101.6 (4)	3.175 (0.125)	2	47.68	95.36	Chassis side beams
3	Bare Square Tube	AL 6063-T54	711.2 (28)	76.2 (3)		3.175 (0.125)	2	29.68	59.36	Support beams
4	Bare Square Tube	AL 6063-T54	711.2 (28)	50.8 (2)		3.175 (0.125)	2	24.64	49.28	Support beams
5	Bare Rectangular Tube	AL 6063-T53	711.2 (28)	38.1 (1.5)	50.8 (2)	3.175 (0.125)	2	20.16	40.32	Handle
6	Bare Sheet	Al 6061-T6	1219.2 (48)	914.4 (36)		3.175 (0.125)	2	123.67	247.34	Fender/ Base plate
7	Bare Drawn Tube	Al 6061-T6	812.8 (32)	31.75 (1.25) i.d	44.45 (1.75) o.d	3.175 (0.125)	1	54.72	54.72	Handle
8	Wheels (Super Z)				330.2 (13) dia		6	87.51	525.06	Wheel sub assembly
9	Bare Extruded Rectangle	Al 6061-T6	1219.2 (48)	31.75 (1.25)		12.7 (0.5)	1	11.23	11.23	Carry loops
Total cost=									1279.79	

**4.2.7. Prototype Testing of Hand Truck:** The hand truck was tested for failure and performance on different terrains. Asphalt and grass terrain was used to record the pushing forces on the truck. The tire pressure for all the tires was maintained at 20 psi and the pushing forces were calculated using a load cell arrangement and verified using a

digital force gauge. Here pushing was considered equivalent of pulling for convenience of measurement. The initial peak force recorded for pushing the cart with a load of 90.7 kg (200 lb) is 9.07 kg (20 lb) to 10.8 kg (24 lb) and the sustained force is 6.3 kg (14 lb) to 8.16 kg (18 lb). On grass the peak force was measured as 18.14 kg (40 lb) with the same load and the sustained force was around 15.8 kg (35 lb). As bridge parts were not available during force measurement, the pushing force values for different bridge parts was approximated based on the values for the 90.7 kg (200 lb) load.

The values of the forces will increase or decrease depending on the load placed on the hand truck. The values were compared with the Liberty Mutual Snook and Ciriello tables [12]. Figure 4.17 shows pushing the hand truck with a top panel on grass and asphalt.



Figure 4.17: Pushing Hand Truck on Grass and Asphalt

The hand truck performed very well in the field test. No failures were observed. The location of the carry bar connection was not inline with the bridge parts placed on the cart. Also the profile of the carry loop for the carry bar connection on the hand truck was not matched to the carry bar connection on the bridge parts. The carry bar connections have to be matched with that of the bridge parts to enable fastening of the bridge parts to

the truck using nylon straps. These changes were made before final delivery of the assists.

### **4.3 CRANE DESIGN**

The crane system was required to ease the strain on soldiers during assembly of a top panel or a bottom panel. The assembly of a top panel or a bottom panel involves lifting and holding the part at a height of over 1.5 m (5 ft). This can cause severe musculoskeletal injuries. To prevent this, an erection panel aid was used initially. But it was inefficient and slow. A need for a crane system to lift panels off the hand truck or ground and assemble with bridge parts was seen. The crane system should be light weight and should be easy to transport and assemble on the bridge parts. This phase of the project involved redesign of the crane system that was designed to ease panel assembly.

**4.3.1 Requirements of a Crane System:** The crane system that is being designed must have the following capabilities:

- 1) Should be designed to lift and hold more than 272 kg (600 lbs).
- 2) Crane should be designed to lift and assemble both top panels and bottom panels to a height of more than 1.8 m (72 in). Electric hoist should be used to lift bridge parts. The hoist should have vertical lift capability of more than 3.65 m (12 ft).
- 3) Crane should be easy to handle and transport and should be capable of being mounted by two soldiers by hand.
- 4) Should be fast enough and perform lifts of top panels and bottom panels in less than 20 seconds.

**4.3.2: First Crane Design:** Based on the inputs from soldiers and engineers, a crane system was designed to provide better functioning, reduced lifting time, easy transportability and assembly. A functional model approach was used to study all parameters and design criteria for the crane system [7].

The material used for the crane system in the first design was AL 6061-T6. Stress analysis of the crane was done by considering the structure as a truss. Forces on each truss member was calculated and was found be well within safety limits. The lifting boom was designed to withstand bending and deflection. The cross-section for the boom was I-beam. The I-beam offered the best cross sectional properties when compared to the hollow beam and the square beam. It showed the best stiffness and resistance to bending.

The I-beam showed a maximum bending stress of 1288354 kg/m<sup>2</sup> (1832.47 lb/inch<sup>2</sup>). The maximum deflection was 0.000148 m (0.00586 in) [7]. As the maximum stress value was much lower than the yield stress for Al 6061-T6, the design was safe. The lug plate, boom I-beam and gusset plate were designed to withstand a load in excess of 226 kg (500 lb) [7]. The crane had four systems:

- 1) The undercarriage system: It is the framework or the base structure of the crane. It supports all other parts of the crane.
- 2) The boom sub system: The boom sub system is the extending portion of the crane that holds the electric hoist and the lifting system. It can be folded during transportation.
- 3) The wire rope system: The wire rope system helps to provide tension and support the crane frame when the boom sub system is loaded.
- 4) The lifting system: The lifting system consisted of an electric powered hoist attached to the top of the boom. A lifting beam was used to lift bridge parts. The lifting beam was



fixed to the hoist and could be lowered or raised. Figure 4.18 shows the crane system assembled to a top panel.



Figure 4.18: First Design of Crane System

The first crane design made use of chains for lifting bridge parts. The chains were attached to the lifting beam and the bridge parts. A field test was conducted to check and validate the design of the crane system. A Harrington hoist was used for the crane system to lift the bridge parts. The hoist had dual speed capability and was mounted on top of the boom sub system. Prototypes were field tested for performance. Figure 4.19 shows the crane system mounted on a top panel and lifting a bottom panel during the field test.

The field test performance of the crane system was very good. Some failures were observed during the testing. The tie down of the wire rope assembly between the undercarriage and the boom system failed during crane operation. There was scope for improvement of the design of the crane system for efficient assembly.



Figure 4.19: First Crane System Design Performing a Bottom Panel Lift

**4.3.3. Modifications Required on the Crane System:** Some design modifications were necessary to facilitate better improved performance. They are:

- 1) Better design for securing the wire rope connections of the boom sub system to the undercarriage. The loops that were provided to connect the wire ropes failed during operation.
- 2) Load balancing was essential as the front portion of the crane system experienced maximum loading and the tension on the wire rope system between the boom and undercarriage was very high.
- 3) The Harrington hoist used for the first design was mounted onto the boom. This led to excessive loading on the boom and counterbalance was necessary. A hoist system that can be mounted on the crane undercarriage was needed to balance loads effectively.

- 4) An effective battery system to power the hoist was essential. To power the hoist during construction, a fast and convenient method was required. Wires and cables around the crane system have to be avoided for the sake of faster and efficient assembly. A battery system that can be integrated with the undercarriage was proposed.
- 5) The chains used for mounting bridge parts got entanglement with each other. A better method of connecting the bridge parts to the crane was proposed. Wire ropes showed lot of advantages. They were entangle free and were easy to handle. Hence wire ropes of suitable length had to be fitted with hooks to mount onto bridge parts.
- 6) Tie down of the crane system onto the Top panel was time consuming. An easier method of fastening the crane onto the bridge system was needed for faster assembly.

**4.3.4. Redesign of the Crane System:** The redesign of the crane system addressed all the issues faced with the first design. The design of all the major load bearing components was maintained the same as the first design. The tie down mechanism of the wire rope from the boom sub system to the undercarriage system was integrated to the system instead of providing a riveted loop for mounting the wire rope. Two plates on either sides of the crane were welded to the undercarriage and the boom sub system. Figure 4.20 shows the welded plates on the under carriage and boom sub system.

The plates for the wire rope assembly showed no sign of failure during testing. They were designed to withstand load of more than 272.15 kg (600 lb). The plate thickness is 0.0127 m (0.5 in) and the distance from the plate hole center to the edge is 0.0254 m (1 in). This ensured good sturdy design.



Figure 4.20: Welded Plates for Wire Rope Assembly

The first design of the crane showed very high loading in the front of the crane system. The boom system was heavily loaded due to the presence of the hoist and the lifting mechanism. The redesign prompted for a different hoist system which can be mounted on the undercarriage and with the help of a pulley system, the lifting beam can be operated. This will ensure better load distribution. For the Harrington hoist system counterbalance was essential. When the hoist is located on the undercarriage, it eliminates the need of counterbalance.

After some research the most suitable hoist for the crane system was the Ramsey Badger 2500. The specifications of the Badger 2500 from the owner's manual [13] are given in figure 4.21.

The hoist for the crane system was mounted onto the undercarriage. A platform was welded on the undercarriage for mounting the hoist. For faster and efficient power supply for the hoist, a battery storage box and mounting was included on the

undercarriage. A 12V DC battery will be used to operate the hoist. The battery is stored in a battery box which is strapped onto the undercarriage. The hoist and battery system ensure an efficient and fast panel assembly. Figure 4.22 shows the hoist and battery system on the undercarriage.

SPECIFICATIONS	
<b>Rated line pull</b>	(single line) 2,500 lbs. (1133 kgs)
<b>Gear reduction ratio</b>	136:1 (12V)
<b>Motor</b>	Permanent magnet - 0.9 hp (12V) DC
<b>Overall dimensions</b>	(LxWxH) 13.19" x 4.50" x 4.83" (335 mm x 114 mm x 123 mm)
<b>Drum size</b>	Diameter 1.75" (44 mm) Length 2.97" (76 mm)
<b>Weight</b>	21 lbs. (9.5 kgs)
<b>Cable supplied</b>	50 ft. (15 m) of 3/16" (4.8 mm) galvanized aircraft cable with replaceable clevis hook
<b>Mounting bolt pattern</b>	3.00±.015 IN X 4.88±.015 IN (76.2 x 124.0 mm)
<b>Brake</b>	Automatic load - holding brake standard

Line pull	(lbs)	NO	500	1,000	1,500	2,000	2,500
first layer	(kgs)	LOAD	227	453	680	906	1,133
Line speed	(fpm)	18	17	15	12	11	7.5
first layer	(mpm)	5.5	5.1	4.6	3.7	3.4	2.3
Amp draw	(12v)	36	54	83	100	109	140

Figure 4.21: Badger 2500 Specifications



Figure 4.22: Hoist and Battery Mounting on Undercarriage

The first design of the crane made use of chains to connect the bridge part to the lifting beam. The chains had an issue of entangling with each other. Lot of time was wasted in untangling the chains. To avoid this, wire ropes were used. The wire rope length for the lifts was calculated. The wire rope lengths from the lifting beam to the bridge panel was calculated for picking up a top panel to a height of up to 1.5 m (59 in) higher than the pickup point (e.g. the ground, or the cart).

To tie down the hoist to the top panel, nylon ratchet straps were used. To ensure faster assembly with the top panel a web straps with quick lock mechanism was proposed. The straps will be hooked to the carry loop connection provided on the crane and the top panel. The carry loops on the crane system was aligned to the carry loop on the top panel. Figure 4.23 shows the crane assembly with the modifications. The hoist can be seen mounted on the undercarriage and a battery box is provided very close to the hoist for the power supply to the hoist system. The battery box can be strapped on to the undercarriage and can be removed easily.



Figure 4.23 Redesigned crane system

**4.3.5. Prototype Testing of Crane System:** The crane assembly was tested for performance. The crane body was robust and did not show any signs of failure. The hoist proved to be adequate for top and bottom panel lifts. Repeated speed test of the winch indicated lift speed of 0.1m (4 in) per second with 181 kg (400 lb) load. The winch lifted a top panel 1.27 m (50 in) in 12 seconds. Using a fully charged 125 amp-hour battery, the winch raised and lowered a top panel 24 times with no indication of performance degradation. One single charge of the battery should be sufficient for panel assembly of a 12 bay bridge.

The pulley mounted on the hoist boom arm failed. The wire rope from the winch wore the plastic surface then wedged between the pulley block frame and the pulley wheel. The pulley system was replaced with a metal pulley system with better load bearing capacity.

The hooks provided did not fit in the carry loop connections on the bridge part. Hooks with a sufficient throat depth was provided to facilitate connection to the bridge part.

The wire rope lengths from the spreader beam to the bridge panel connection were just about the perfect length for picking up a top panel to a height of up to 1.5m (59 in) higher than the pickup point (e.g. the ground, or the cart). To accommodate lifting the bottom panel, a small section of chain with another hook at the end was connected to the wire rope hook and used as an extender. Additional four 0.304 m (12 in) sections of chain with hooks were provided.

## **5. ENERGY EXPENDITURE PREDICTION ANALYSIS**

Energy expenditure prediction while performing a manual material handling task is a method of estimating a worker's capability of performing the task. Metabolic energy expenditure rate is a physiological measure used to determine the maximum safe task exertion by a worker without excessive physical fatigue. The measurement of metabolic energy expenditure is also used for evaluating alternate work methods and to establish duration and frequency of rest breaks for workers. [14]. Energy Expenditure Prediction Program™ (EEPP) is a software program developed by University Of Michigan's Center for Ergonomics to predict the energy expenditure rates for manual material handling tasks.

### **5.1. ENERGY EXPENDITURE PREDICTION PROGRAM (EEPP)**

The main principle or idea behind EEPP is that a job is divided into simple tasks or elements and that the average metabolic energy expenditure rate of the job is predicted by knowing the energy expenditures of the simple tasks and the time duration of the job. By dividing the job into task elements and estimated the energy expended by a worker for that particular task element, an energy requirement for the task element is predicted [3]. As explained in chapter 1, the average metabolic energy expenditure of a task is equal to the sum of energy demand of all the task elements and the maintenance of body posture averaged over time. There are several advantages of using EEPP [15], they are:

- 1) EEPP is easy to understand and apply to many different manual material handling jobs and is non technical in nature.



2) It gives a measurable value to gauge worker safety, compare and improve design. It also gives a summary to compare with NOISH standards and guidelines.

3) It is more accurate than standard published energy expenditure values from published data.

The main parameters that is required for estimating the task element energy expenditure are Gender of the worker, Body weight, Weight of the load or force applied, Frequency of loading, Vertical and horizontal range of hand movement, Speed of walking and carrying loads, Body posture, Time duration of the task.

All predictions on EEPP are made based on these eight factor values. All other factors play a minor role and are not as big as the eight listed above and hence are not included in the model for calculations.

Niebel [21] further suggested that the accuracy of prediction depends on several factors, including:

- 1) The accuracy and completeness of division of the job into tasks.
- 2) The analysis of the job should be correct.
- 3) The availability of a prediction equation to define the task precisely.
- 4) The accuracy of the task equation itself.

Totally nine different task elements are considered to breakdown a task on EEPP. All nine or some of the task elements are used to define a task. The summation of the energy prediction of all tasks gives the energy expenditure for the job.

The nine task elements are:

- 1) Lifting: At the lower height range two commonly used techniques are stoop and squat. The different techniques of lift used are stoop lift, squat lift, one hand lift, arm lift. Lifts above 0.81 m (32 in) are considered arm lifts.
- 2) Lowering: Lowering is the opposite of lifting and makes use of similar parameters to define tasks. The parameters that are used to define lifting/lowering tasks are the frequency, beginning height from floor, final height from floor and weight of the load.
- 3) Push/Pull: For pushing of loads the techniques that are used are pushing regular loads, pushing inertial loads forward or backward and pushing inertial load sideways. The parameters that are used in the prediction equations are frequency of the task, peak force, displacement and/or time taken, height of hands. Pulling is assumed to be approximated by pushing.
- 4) Holding: The four techniques used here are load held against front of thighs using two hands at arm length, load held against front of waist using two hands, load held in both hands at arms length at sides and load held in one hand at arm length at side. The parameters that are used in the prediction equations are the frequency of the task, time taken for the task and the weight of the task.
- 5) Walking: The technique used here is walking on flat or inclined surface. The parameters required for the prediction equation is the grade of the surface, frequency, time taken and distance travelled.
- 6) Carrying: Carrying is similar to holding but there are two significantly different equations for carrying, they are carrying with one or both hands at arms length at sides and carrying against thighs or against waist.

7) Arm Work: There are four different types of arm work: horizontal arm work, lateral arm work, general arm work and inertial arm work. The four postures used for horizontal arm work are standing using both hands, standing one hand, sitting both hands and sitting one hand. Lateral arm work is the work which involves lateral movement of the arms in the horizontal plane. The different postures for lateral arm work are a) lateral arm work 180 degrees with both hands b) lateral arm work 180 degrees with one hand c) lateral arm work 90 degrees, standing with one or both hands d) lateral arm work 90 degrees, sitting with both hands e) lateral arm work 190 degrees, sitting with one hand. For general arm work light and heavy arm work with one or both arms (light or heavy loads) was considered. Inertial arm work is again classified as lateral inertial arm work (90 degrees or 180 degrees) and general inertial arm work (shorter movements or larger movements).

8) Hand Work: Hand work is used for jobs that require a significant amount of small hand movements. The different techniques are hand work light or heavy, hand work one arm (light or heavy), hand work both arms (light or heavy). There is no clear differentiation between light and heavy arm/hand work. If arm work involves loads more than 5 pounds per arm, it should be classified as heavy arm work.

9) Climbing steps: Climbing steps at a regular pace is used as a technique here. The main parameters required for the prediction equation is weight of the load, number of steps taken and the frequency per task cycle.

The above nine different task elements are used exclusively on EEPP. The parameters that are needed for calculating the task energy are observed and noted from the job analysis. Figure 5.1 and 5.2 shows screenshots of job and task description on EEPP for the current assists.

**Worker Profile Entry**  
Worker Name/ID: MGB Soldier  
Gender:  Male  Female  
Body Weight: 175 pounds

**Job Profile Entry**  
Job Name: MGB Bridge Build  
Job Location: Ft Leonard Wood  
Job Analyst: Karthik  
Date: 02/21/2010

**Job Energy Summary Report**  
Job Duration: 2.65861 hours  
Job Energy: 880.51 Kcal  
No. of Tasks: 10  
Job Energy Rate: 5.52 Kcal/min

**Task Portfolio**

Name	Duration (hrs)	No. of Elements	Energy (Kcal)	Energy Rate (Kcal/Min)
End Taper Panel	0.1233	4	43.61	5.89
Bankseat B...	0.0583	5	21.55	6.16
Top Panel-1	0.1055	5	37.66	5.95
Top Panel-2	0.5055	3	156.69	5.17
Junction Pa...	0.066	3	28.15	7.11
Bottom Pan...	0.664	3	197.58	4.96
Deck	.85	3	299.92	5.88

Buttons: Add Task, Edit Task, Delete Task, Help  
Task Selected: End Taper Panel

Figure 5.1: Job Descriptions on EEP

**Task Information**  
Element #: 1  
Description: Unload End Taper Panel from EOB pallet  
General: Lower  
Advanced: Arm  
Frequency per task cycle: 1  
Beginning height from floor (inches): 55  
Final height from floor (inches): 36  
Weight of the load (pounds): 100

No.	Type	Advanced	Frequency	Force	Ini. Pos.	Fin. Pos.	Time	Dist/Steps	Grade	Energy
1	Lower	Arm	1.00	100.00	55.00	36.00				0.30
2	Carry	Loads	1.00	100.00			0.60	60.00	0.00	4.13
3	Lift	Arm	1.00	100.00	32.00	45.00				0.36
4	Carry	Loads	1.00	100.00			0.42	4.00	0.00	2.47

**Energy Summary**  
Total Posture Energy (Kcal): 3.65  
Total Elements Energy (Kcal): 7.25  
Cycle Energy (Kcal/cycle): 10.91  
Total Number of Cycles: 4.00  
Total Task Energy (Kcal): 43.61  
Task Energy Rate (Kcal/min): 5.89

Buttons: Clear Form, Delete element, Update/Add element, Help, Return to Job

Figure 5.2: Task Descriptions on EEP

As seen from the figures 5.1, the worker profile and job profile are defined initially. The tasks used to describe the job are created in the task portfolio by clicking on the add task button, located at the bottom of the task portfolio seen in figure 5.1. The cycle time and task time required for a task is entered in the task information tab seen in figure 5.2. The parameters and type of task element used is described in the task element tab seen in figure 5.2.

## **5.2. PARAMETER PREDICTION DURING BRIDGE BUILD**

The bridge build process was analyzed carefully using recorded videos of the bridge build previously done and also by using recorded videos of the field tests done. Several different methods were proposed to analyze the bridge building process. The most feasible and effective method was to split the bridge build process based on assembly of important bridge parts. Nine important parts were identified for the bridge build. They are

- 1) End Taper Panel
- 2) Bankseat Beam
- 3) Top Panel
- 4) Bottom Panel
- 5) Junction Panel
- 6) Deck
- 7) Long Ramp
- 8) Roller Beam
- 9) Heavy Launching Nose

Each part was studied carefully using video recording available from previous field tests and also by referring to the operator's manual of MGB. The three main stages for manual assembly of a bridge part are

- 1) Unloading of the bridge part from pallet: Each part has to be unloaded from a pallet and carried to the bridge construction site and assembled.
- 2) Carrying/pushing/pulling bridge part from pallet to construction site: Each part has to be manually carried to the construction site or pushed or pulled using a hand truck to the construction site for assembly.
- 3) Assembly of bridge part: It is the assembly of the bridge part with other bridge parts.

As EEPP can be used to predict energy expenditure for a single person, the load was divided equally among the number of soldiers performing the task. To calculate the energy expenditure of the entire team, the energy expenditure of a single soldier was multiplied by the number of soldiers involved in the particular task. The bridge build energy expenditure analysis on EEPP is done by estimating key prediction equation parameters. The main parameters that were captured from the recorded videos and the operator's manual are:

- 1) Height of bridge part on pallet: This is the initial height for lifting/lowering the bridge part from the pallet. An average height value is estimated by looking at the way the parts are arranged on the pallet. The operator's manual was used exclusively for this.
- 2) Final height for carrying the part: The most comfortable height for carrying the bridge parts is 0.81 m (32 in). The final height of the bridge part after the lift/lower from the pallet is noted.

3) Distance travelled: The total distance travelled for carrying the bridge part from pallet to the construction site is noted.

4) Assembly Method: The assembly method and its important parameters are captured. The bridge can be assembled by just a lift operation or arm/hand work. The parameters such as peak force applied, hand movement, distance is recorded here.

5) Time for each task element: The time required for each task element such as lift, lower, carry, and arm work is noted. The summation of time for all task elements is the task cycle time. This is multiplied by the number of cycles to give the total task duration.

For simplifying of the MGB bridge build analysis, several assumptions were made. They are:

1) Bridge assembly is considered to consist of only nine important parts. All other small assemblies are not considered.

2) All lift heights, distance travelled and assembly techniques are approximated from the recorded field test videos and operator's manual. The values may be different during an actual bridge build. A field test has to be conducted to verify the results and capture the required data for energy prediction.

3) Only major operations performed by the soldiers are considered. Walking to the site, minor arm work and lifts/lowers are not considered for the analysis.

4) Load is assumed to be uniformly distributed among the number of soldiers performing a task. Also a 50 percentile male is considered for simplicity of analysis. Each task is identified as a single person task by dividing the load by the number of soldiers performing the task. EEPP is capable of analyzing individually performed tasks only.

5) EEPP software uses United States customary unit system for all parameters. Hence this system of units is followed for all parameters that are used on EEPP.

The energy expenditure analysis was performed for both the current mechanical assists and the new redesigned mechanical assists. The energy values obtained for both were compared and analyzed.

### **5.3. EEPP ANALYSIS OF CURRENT ASSISTS**

The EEPP analysis of the current assists included time and motion study of soldiers performing tasks from recorded field test videos and bridge building videos. All necessary and required parameters were based from the recorded videos and the operator's manual. Each operation of the bridge assembly was studied carefully and every step taken by a soldier during assembly of the bridge was studied.

The number of tasks considered for the analysis was ten. The top panel assembly was considered as two different tasks. Top panel-1 was considered for assembly with end taper panel and junction panel at both ends of the bridge. Top panel-2 was considered from junction panel onwards to the end of the bridge. Top panel-2 formed the flat roadway girders. Both top panels have different assembly methods, hence they were considered as different tasks.

A 12 bay bridge was considered for analysis. A total of 24 crew members were required for the assembly as per the manual. Table 5.1 shows the individual requirement of the ten important bridge parts. The total weight of the bridge part was divided by the number of soldiers handling the bridge part and energy expenditure for a single soldier performing the task was estimated.



Table 5.1: MGB Part Requirements for 12 Bay Bridge

SL NO	COMPONENT	# PEOPLE REQUIRED TO CARRY	# REQUIRED FOR 12 BAY MGB
1	End Taper Panel (ETP)	6	4
2	Bank Seat Beam (BSB)	6	2
3	Top Panel-1 (TP1)	4	4
4	Top Panel-2 (TP2)	4	28
5	Junction Panel (JP)	4	4
6	Bottom Panel (BP)	4	24
7	Deck	2	68
8	Long Ramp (LR)	4	14
9	Roller Beam (RB)	4	2
10	Heavy Launching Nose (HLN)	4	6

Assembly of each bridge part was studied and assembly of a part right from unloading it from a pallet, carrying to the construction site and assembly with other bridge parts was observed. Each part assembly was split into various task elements depending on whether the task is a lifting, lowering, carrying or arm work. Important parameters for each task element were noted and parameters are listed in table 5.2. The Procedure for assembly of each bridge part was observed and the same procedure was followed for EEPP analysis. The peak force values for performing arm work was approximated based on the load that is being lifted. For lifting tasks the initial lift/lower heights and the final lift/lower heights were estimated from the operator's manual and bridge videos.

Table 5.2: Task Description and Parameter Values with Current Assists

SL NO	COMPONENT	TASK	TASK TYPE-EEPP	INITIAL HEIGHT (in)	FINAL HEIGHT (in)	TIME TAKEN FOR TASK ELEMENT (Sec)	Peak Force (lbs)	DISTANCE TRAVELLED (ft)
1	End Taper Panel (ETP)	Unload ETP from pallet	Lower(Arm)	55	36	25	n/a	n/a
		Carry ETP from pallet to site	Carry(Against thighs or Waist)	n/a	n/a	36	n/a	60
		Place ETP on FRB	Lift(Arm)	32	45	25	n/a	n/a
		Assemble ETP	Carry(Against thighs or Waist)	n/a	n/a	25	n/a	4
2	Bank Seat Beam (BSB)	Unload BSB from EOB pallet	Lower(Arm)	66	30	25	n/a	n/a
		Carry BSB from EOB pallet to site	Carry(Against thighs or Waist)	n/a	n/a	30	n/a	50
		Assemble BSB with ETP	Lift(Arm)	30	54	14	n/a	n/a
		Assemble BSB with ETP	Carry(Against thighs or Waist)	n/a	n/a	20	n/a	4
		Assemble BSB with ETP	Arm Work (Inertial- General)	n/a	n/a	16	45	n/a
3	Top Panel-1 (TP1)	Unload TP-1 from EOB pallet	Lift(Stoop)	27	36	15	n/a	n/a
		Carry TP-1 from pallet to site	Carry(Against thighs or Waist)	n/a	n/a	25	n/a	50
		Assemble TP-1 with BSB/TP-1	Lift(Arm)	36	54	10	n/a	n/a
		Assemble TP-1 with BSB/TP-1	Carry(Against thighs or Waist)	n/a	n/a	30	n/a	5
		Assemble TP-1 with BSB/TP-1	Arm Work (Inertial-General)	n/a	n/a	15	45	n/a
4	Top Panel-2 (TP2)	Unload TP-2 from DSC pallet	Lift(Arm)	33	42	15	n/a	n/a
		Carry TP-2 from pallet to site	Carry(Against thighs or Waist)	n/a	n/a	20	n/a	45
		Assemble TP-2 with BSB	Lift(Arm)	42	72	30	n/a	n/a
5	Junction Panel (JP)	Unload JP from EOB pallet	Lift(Stoop)	20	24	10	n/a	n/a
		Carry JP to site	Carry(Against thighs or Waist)	n/a	n/a	25	n/a	50
		Assemble JP with BSB	Lift(Stoop)	14	54	25	n/a	n/a
6	Bottom Panel (BP)	Unload BP from Pallet	Lift(Stoop)	31	36	15	n/a	n/a
		Carry BP to Site	Carry(Against thighs or Waist)	n/a	n/a	25	n/a	50
		Assemble BP with TP	Lift(Arm)	7	54	30	n/a	n/a
7	Deck	Unload deck from pallet	Lift(one hand)	28	30	10	n/a	n/a
		Carry deck to site	Carry(At arms.one hand)	n/a	n/a	25	n/a	50
		Assemble with TP	Lower(Stoop)	30	8	10	n/a	n/a
8	Long Ramp (LR)	Unload Ramp from pallet	Lift(Stoop)	22	32	10	n/a	n/a
		Carry Ramp to site	Carry(At arms.one hand)	n/a	n/a	25	n/a	50
		Assemble	Lower(Stoop)	32	12	15	n/a	n/a
9	Roller Beam (RB)	Unload RB from Pallet	Lift(Stoop)	30	36	10	n/a	n/a
		Carry RB to site	Carry(Against thighs or Waist)	n/a	n/a	20	n/a	50
		Lower RB to assemble	Lower(Stoop)	36	8	10	n/a	n/a
		Assemble with adjustable support	Arm Work (Inertial- General)	n/a	n/a	15	30	n/a
10	Heavy Launching Nose (HLN)	Unload HLN from Pallet	Lift(Stoop)	15	36	10	n/a	n/a
		Carry HLN to site	Carry(Against thighs or Waist)	n/a	n/a	20	n/a	50
		Lower HLN to assemble	Lower(Stoop)	36	12	10	n/a	n/a
		Assemble	Arm Work (Inertial- General)	n/a	n/a	10	35	n/a

Table 5.2 shows all the tasks (bridge parts) and tasks elements for each bridge part in MGB construction. The assembly procedure of each bridge part is also given in table 5.2. The type of task performed is also listed along with the necessary parameter values for the prediction equation. The total distance the bridge part is carried is approximated to 15.24 m (50 ft) or 18.28 m (60 ft) depending on the part.

Time taken to complete each task element was recorded from the available videos. The task cycle time is the summation of all the task element times. The total task duration is given by the task cycle time multiplied by the number of cycles.

**5.3.1. EPP Results of Current Assists:** Figure 5.3 gives the summary of the job energy expenditure.

Job Energy Expenditure Summary					
<b>Worker Profile</b>					
Worker Name/ID:	MGB Soldier				
Gender:	Male				
Body Weight:	175 pounds				
<b>Job Profile</b>					
Job Name:	MGB Bridge Build				
Job Location:	Ft Leonard Wood				
Job Analyst:	Karthik				
Date:	02/21/2010				
<b>Task Portfolio</b>					
Job Duration:	2.69201 hours				
No. of Tasks:	10				
Job Energy:	895.84 Kcal				
Job Energy Rate:	5.55 Kcal/min				
Name	Duration (hr.)	Elements	Energy (Kcal)	Energy Rate (Kcal/min.)	Description
End Taper Panel	0.1233	4	43.61	5.89	Unload Taper Panel from pallet, carry to construction site and assemble with FRB
Bankseat Beam	0.0583	5	21.55	6.16	Unload from pallet, carry to construction site and assemble with taper panel
Top Panel-1	0.2111	5	75.37	5.95	Unload TP-1, carry to site and assemble with BSB
Top Panel-2	0.4333	3	134.31	5.17	Unload TP-2 from pallet, carry to site and assemble with JP or TP
Junction Panel (JP)	0.066	3	28.15	7.11	Unload JP, carry to site and assemble with TP
Bottom Panel (BP)	0.664	3	197.58	4.96	Unload BP, carry to site and assemble with TP
Deck	0.85	3	299.92	5.88	Unload Deck, carry to site and assemble
Long Ramp	0.1944	3	57.23	4.91	Unload Ramp, carry to site and assemble
Roller Beam	0.0305	4	10.97	5.99	Unload RB from pallet, carry to site and assemble with adjustable supports
Heavy Launching Nose (HLN)	0.06111	4	27.15	7.40	Unload HLN, carry to site and assemble with HLN/LLN

Figure 5.3: Job Energy Expenditure Summary

Theoretically if a soldier is involved in the assembly of all the bridge parts, he would expend energy at a rate of 5.55 Kcal/min. But practically a single soldier is not involved in all tasks. Hence the task energy rate is of more importance than the job energy rate.

The figure shows the worker profile, job profile and the task summaries of all the tasks involved in MGB construction. It gives the energy expenditure rate and energy expended for all ten tasks of MGB construction. Figure 5.4 shows the graph of task energy rate versus bridge parts.

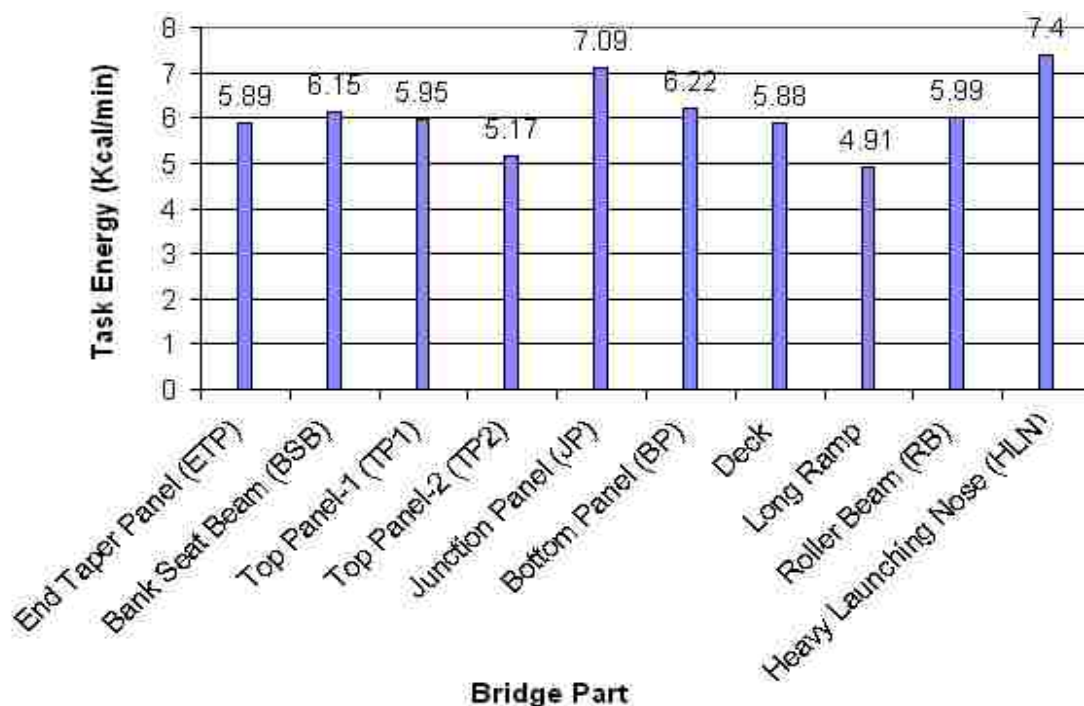

Figure 5.4: Total Task Energy Rate for Bridge Parts

The figure graph shows that the task energy expenditure rates for all parts exceed the 3.5 Kcal/min action limit guideline for an average 8-hour day set by the National Institute for Occupational Safety and Health (NIOSH) [23]. The tasks also exceed the 5 Kcal/min action limit set by NIOSH which describes the job acceptable if administrative control is invoked. The task energy shown in the above graph is for one complete bridge. The soldiers experienced high strain and fatigue and redesign of the assists was suggested to improve comfort and safety of the soldiers.

EEPP analysis of the first redesign was not carried out. Instead EEPP analysis of the new second redesign was carried out and compared with the current assist analysis results.

#### 5.4. EEPP ANALYSIS OF REDESIGNED ASSISTS

The EEPP analysis of the second redesign of the mechanical assists was carried out. The analysis was carried out similar to the current assists. The new hand truck and crane system were introduced to assist soldiers to lift bridge parts to assemble with the bridge and to carry bridge parts from pallet to the construction site.

A performance test was done to test the functioning and performance of the hand tools, hand truck and the crane. The EEPP analysis of the MGB construction with redesigned assists was entirely based on the results of the performance test and the recorded field test videos of the MGB construction with current assists. The distances for pushing bridge parts, lift/lower initial and final heights were estimated from the recorded videos. The crane parameters (time and motion parameters) were based from the performance test.

Table 5.3 gives all the task element descriptions for the ten tasks (bridge parts). Pushing/Pulling is a new task element when compared to the previous EEPP analysis. Pushing/Pulling task was considered for the hand truck. Lifting and carrying of the crane system to the construction site was not included in the analysis. However the assembly of the hoist onto the bridge top panel was considered. As seen from table 5.3, the lift start heights and final heights for the new improved hand tools increased by 0.355 m (14 in) for the carry bar and by 0.152 m (6 in) for the carry handle. Thereby reducing stoop lift and squat postures. The pushing/ pulling of the bridge parts were considered to be done by a single soldier. It was assumed that a single part is pushed /pulled at a given point of time for simplicity of analysis. The average peak force required to push/pull the bridge parts was 27.2 kg (60 lb). This was compared with Liberty Mutual Snook and Ciriello

tables [12]. The Crane system was considered only for assembly of top panel-2 and the bottom panel.

Table 5.3: Task Description and Parameter Values with Redesigned Assists

SL NO	COMPONENT	TASK	TASK TYPE-EPPP	INITIAL HEIGHT (in)	FINAL HEIGHT (in)	TIME TAKEN FOR TASK (Sec)	Peak Force (lbs)	HORIZONTAL DISPLACEMENT (ft)	DISTANCE TRAVELLED (ft)
1	End Taper Panel (ETP)	Unload ETP from pallet and place on cart	Lower(Arm)	69	40.5	25	n/a	n/a	n/a
		Push ETP from pallet to site	Push/pull (Inertial load forward/backward)	n/a	n/a	18	85	60	n/a
		Place ETP on FRB	Lift(Arm)	40.5	59	25	n/a	n/a	n/a
		Assemble ETP	Carry(Against thighs or Waist)	n/a	n/a	25	n/a	n/a	4
2	Bank Seat Beam (BSB)	Unload BSB from pallet and place on cart	Lower(Arm)	80	40.5	25	n/a	n/a	n/a
		Push BSB on cart to site	Push/pull (Inertial load forward/backward)	n/a	n/a	15	80	50	n/a
		Assemble BSB with ETP	Lift(Arm)	40.5	68	20	n/a	n/a	n/a
		Assemble BSB with ETP	Carry(Against thighs or Waist)	n/a	n/a	20	n/a	n/a	4
3	Top Panel-1 (TP1)	Unload TP-1 from EOB pallet and place on cart	Lift(Arm)	41	43.5	15	n/a	n/a	n/a
		push TP-1 from pallet to site	Push/pull (Inertial load forward/backward)	n/a	n/a	15	55	50	n/a
		Assemble TP-1 with BSB/TP-1	Lift(Arm)	43.5	68	10	n/a	n/a	n/a
		Assemble TP-1 with BSB/TP-1	Carry(Against thighs or Waist)	n/a	n/a	30	n/a	n/a	5
4	Top Panel-2 (TP2)	Unload TP-2 from pallet and place on cart	Lower(Arm)	47	40.5	15	n/a	n/a	n/a
		Push TP-2 from pallet to site	Push/pull (Inertial load forward/backward)	n/a	n/a	15	65	45	n/a
		Assemble hoist onto TP	Arm Work (Inertial- General)	n/a	n/a	15	20	n/a	n/a
		Assemble TP-2 with TP-1/TP-2	Arm Work (Inertial- General)	n/a	n/a	15	10	n/a	n/a
5	Junction Panel (JP)	Unload JP from EOB pallet and place on cart	Lift (Arm)	34	48.5	10	n/a	n/a	n/a
		Push/Pull JP to site	Push/pull (Inertial load forward/backward)	n/a	n/a	20	68	50	50
		Assemble JP with BSB	Lift(Arm)	46	68	25	n/a	n/a	n/a
6	Bottom Panel (BP)	Unload BP from Pallet	Lower(Arm)	45	41.5	15	n/a	n/a	n/a
		Push/Pull BP to Site	Push/pull (Inertial load forward/backward)	n/a	n/a	15	62	50	50
		Assemble hoist onto TP	Arm Work (Inertial- General)	n/a	n/a	15	20	n/a	n/a
		Assemble BP with TP	Arm Work (Inertial- General)	n/a	n/a	12	10	n/a	n/a
7	Deck	Unload deck from pallet	Lift (Arm)	34	40.5	10	n/a	n/a	n/a
		Push/Pull deck to site	Push/pull (Inertial load forward/backward)	n/a	n/a	15	45	50	50
		Assemble with TP	Lower(Stoop)	40.5	14	15	n/a	n/a	n/a
8	Long Ramp	Unload Ramp from pallet	Lift(Arm)	36	40.5	10	n/a	n/a	n/a
		Push/Pull Ramp to site	Push/pull (Inertial load forward/backward)	n/a	n/a	15	57	50	50
		Assemble	Lower(Stoop)	40.5	26	15	n/a	n/a	n/a
9	Roller Beam (RB)	Unload RB from Pallet	Lower(Stoop)	30	25	10	n/a	n/a	n/a
		Push/Pull RB to site	Push/pull (Inertial load forward/backward)	n/a	n/a	15	45	45	n/a
		Lift RB from cart and lower to assemble	Lower(Stoop)	25	8	10	n/a	n/a	n/a
10	Heavy Launching Nose (HLN)	Assemble with adjustable support	Arm Work (Inertial- General)	n/a	n/a	15	30	n/a	n/a
		Unload HLN from Pallet	Lift(Stoop)	29	40.5	10	n/a	n/a	n/a
		Push/Pull HLN to site	Push/pull (Inertial load forward/backward)	n/a	n/a	15	55	n/a	50
		Lift HLN from cart and lower to assemble	Lower(Stoop)	40.5	26	10	n/a	n/a	n/a
		Assemble with adjustable support	Arm Work (Inertial- General)	n/a	n/a	10	45	n/a	n/a

#### 5.4.1. EPPP Results of Redesigned Assists: Analysis was carried out on EPPP

with the parameters values shown in table 5.3. Figure 5.5 shows the summary of the EPPP analysis. The task energy expenditure levels of the 10 bridge parts were plotted and can be seen in figure 5.6.

Job Energy Expenditure Summary					
<b>Worker Profile</b>					
Worker Name/ID:	MGB Soldier				
Gender:	Male				
Body Weight:	175 pounds				
<b>Job Profile</b>					
Job Name:	MGB Bridge Build				
Job Location:	Ft Leonard Wood				
Job Analyst:	Karthik				
Date:	02/21/2010				
<b>Task Portfolio</b>					
Job Duration:	2.171833 hours				
No. of Tasks:	10				
Job Energy:	459.15 Kcal				
Job Energy Rate:	3.52 Kcal/min				
Name	Duration (hr.)	Elements	Energy (Kcal)	Energy Rate (Kcal/min.)	Description
End Taper Panel	0.1033	4	9.13	4.70	Unload Taper Panel from pallet, push to construction site and assemble with FRB
Bankseat Beam	0.053333	5	16.55	5.17	Unload from pallet, push to construction site and assemble with taper panel
Top Panel-1	0.0944	5	31.23	5.51	Unload TP-1, push to site and assemble with BSB
Top Panel-2	0.4666	4	88.12	3.15	Unload TP-2 from pallet, push to site and assemble with JP or TP
Junction Panel (JP)	0.0611	3	14.25	3.89	Unload JP, push to site and assemble with TP
Bottom Panel (BP)	0.38	4	73.89	3.24	Unload BP, push to site and assemble with TP
Deck	0.755	3	148.31	3.27	Unload Deck, push to site and assemble
Long Ramp	0.1554	3	30.48	3.27	Unload Ramp, push to site and assemble
Roller Beam	0.0277	4	6.02	3.62	Unload RB from pallet, push to site and assemble with adjustable supports
Heavy Launching Nose (HLN)	0.075	4	21.17	4.70	Unload HLN, push to site and assemble with HLN/LLN

Figure 5.5: Job Energy Expenditure Summary for Bridge Parts Using New Assists

It is clearly seen from figure 5.5 that the total job energy rate (3.52 Kcal/min) is 36% lesser than the job energy rate of bridge parts with current assists (5.55 Kcal/min). The individual task energy rates are closer to the 3.5 Kcal/min prescribed safety limit. Figure 5.6 shows a plot of task energy rate versus the bridge part. The analysis showed reduction in the total task energy rates of all the bridge parts. On an average, 33% reduction in the task energy rate was seen. Some of the bridge parts still had task energy rates more than 3.5 Kcal/min. The Bankseat beam and the Top panel-1 showed the highest energy expenditure rates. This is due to the fact that both the parts had assembly procedure same as assembly with current assists. Only pushing was the additional task elements for both the parts.

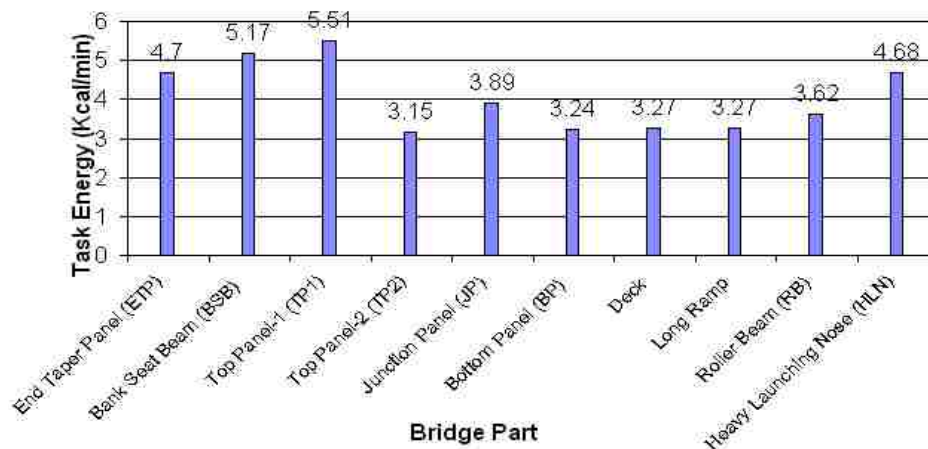

Figure 5.6: Total Task Energy Rate for Bridge Parts Using New Assists

## 5.5. COMPARISON OF EAPP ANALYSIS OF BOTH ASSISTS

EAPP analysis of both the current and redesigned assists showed that there is tremendous improvement in the energy expenditure rates of the soldiers while using the redesigned mechanical assists. The three most important comparison factors are the task energy expenditure rate for a soldier, time taken for a task and the team energy expenditure.

1) The task energy expenditure rate is the energy expenditure rate of a soldier in Kcal/min for a particular task. A task is defined as the assembly of the required number of a particular bridge part. Hence there are 10 different tasks for a MGB build. The average task energy rate was reduced by 33% (from 6.065 Kcal/min to 4.05 Kcal/min) for the new redesigned bridge parts. Figure 5.7 shows the task energy rate comparison of both the current and redesigned assists.



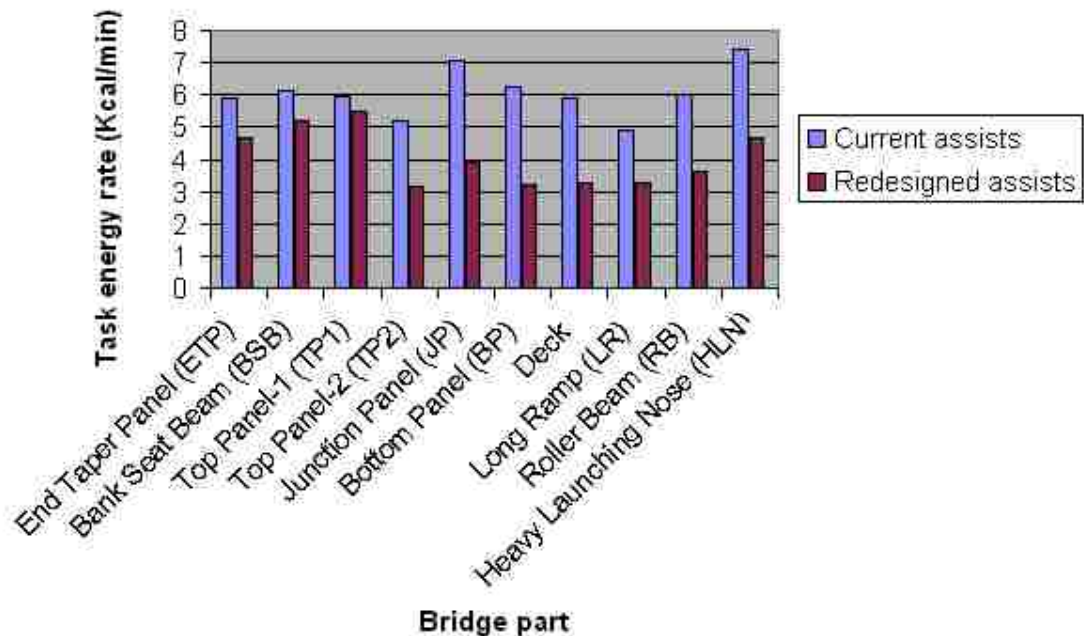

Figure 5.7: Task Energy Rate Comparison

2) The total task time is another important factor for comparison. Time required to assemble a single bridge part is considered as the cycle time. Time required to assemble all required number of a particular bridge part is the task time. The redesigned assists reduced the average task time for assembly of all parts by 12% (0.2488 hr to 0.217 hr). This is mainly due to the use of the hand truck and the crane system. The hand truck reduced the time taken transport the bridge parts from the pallet to the construction site and the crane system reduced panel assembly time. This will improve and make the bridge construction process faster and efficient. Figure 5.8 shows the task time in hours for both current assists and new redesigned assists.

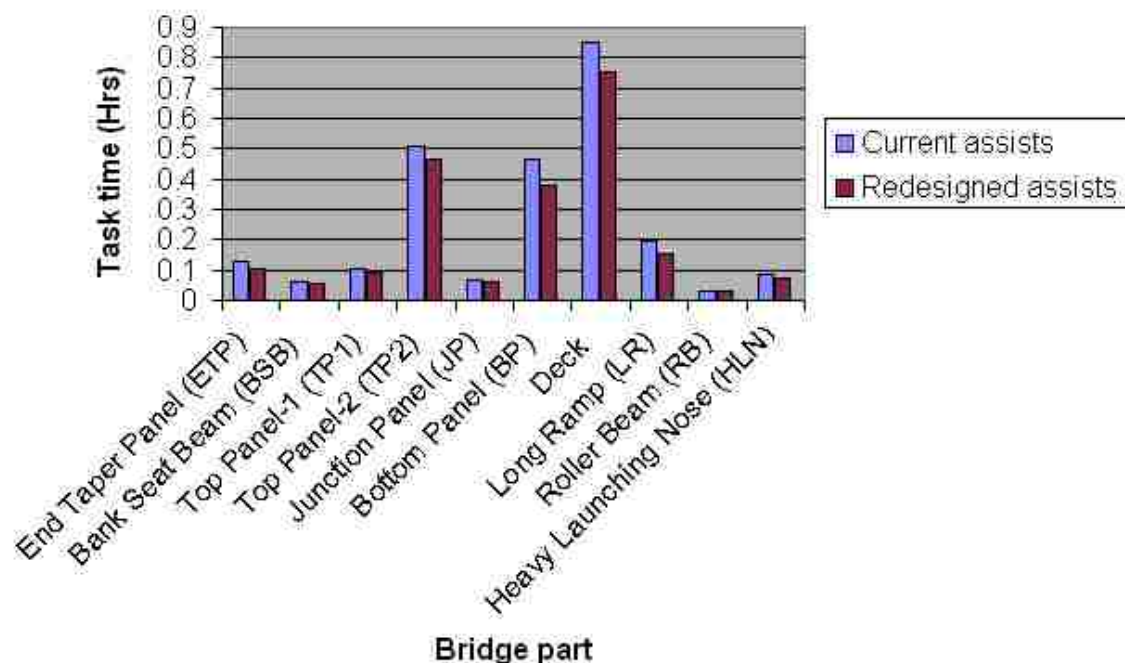

Figure 5.8: Task Time Comparison

3) The team task energy is the third important factor for comparison. The team task energy for each part was calculated. The team task energy is the total energy a team expends during assembly of all bridge parts. Each bridge part is assembled by a team of soldiers. The total team energy is estimated as the sum of individual task elements times the number of cycles times the number of soldiers and the total posture energy of the team. The team energy expenditure is essential to analyze the energy expended by a team of soldiers, as the parts are assembled by a team rather than one soldier. Figure 5.9 shows the team energy comparison of current and redesigned mechanical assists.

The average team energy expenditure for the bridge build was reduced by around 56% (from 316.4 Kcal to 138.4 Kcal). This shows tremendous improvement in the strain and fatigue levels of the soldiers. Also the most strenuous assembly was that of bottom

panel and top panel. The assembly of both was eased by the use of the hand truck and the crane.

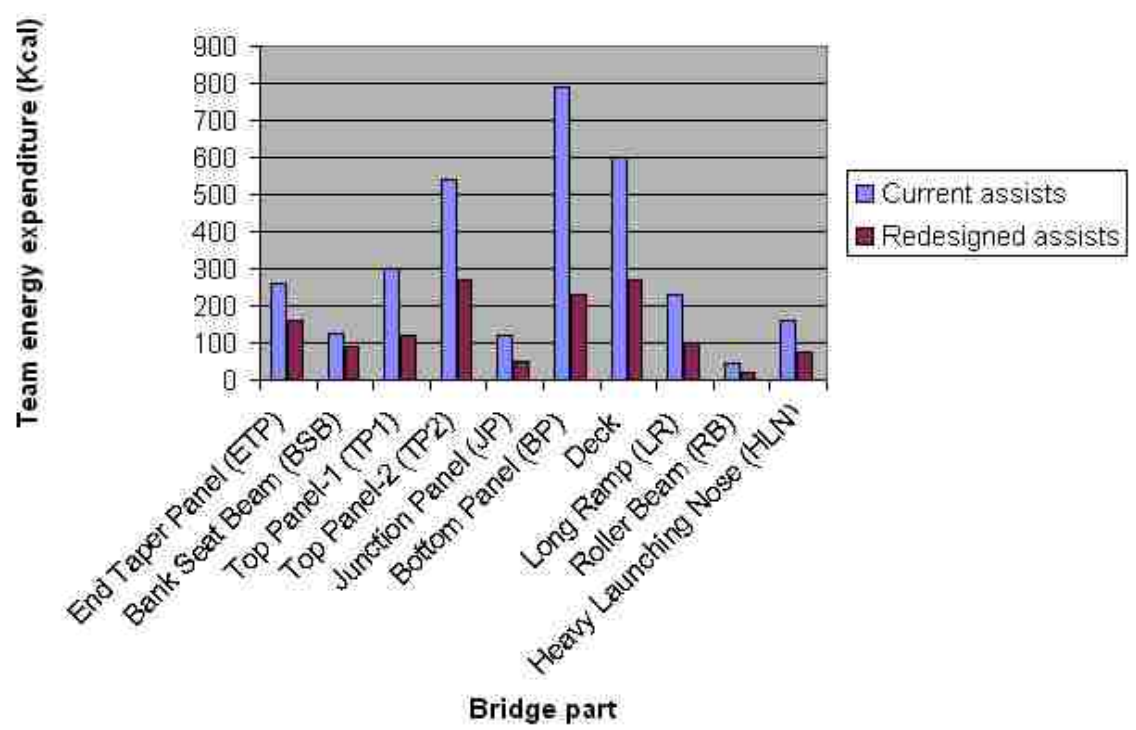

Figure 5.9: Team Energy Rate Comparison

From the EPP analysis, it is evident that the redesign of the mechanical assists significantly reduces the severity of the tasks that contribute to musculoskeletal injuries. The new redesign presents major ergonomic improvement. The redesign of the assists helps in reducing the number of soldiers handling the bridge parts. For example pushing of a hand truck requires only one soldier when compared to current assists which required a minimum set of soldiers to carry a bridge part. Irrespective of the size of the bridge part, one soldier can comfortably push the hand truck and transport the bridge part to the construction site. Assembly of some of parts such as Top panel-2 required the part to be

lifted to a height of 1.67 m (5.5 ft) to 1.828 m (6 ft) from the ground. It posed great safety and health hazards for the soldiers. With the addition of the crane system for the redesigned parts, the parts only need to be aligned and locked in place. Lifting is done by the crane. The crane lifts are fast and very efficient for repetitive bridge assembly tasks.

The redesigned bridge parts have to be field tested to validate and improve the bridge construction process. The design of the bridge build can be improved to achieve better energy expenditure rates.

## 6. CONCLUSIONS AND FUTURE WORK

The redesigned mechanical assists improved ergonomics standards for MGB construction. An effort was made to study and analyze the bridge build process with the redesigned mechanical assists using EEPP. The results showed tremendous improvement in posture, energy expenditure rates and task time. Prototypes were tested. The prototypes performed well under different loading conditions. The hand tools were easy to disassemble and transport. The carry bar is modular in design to facilitate easy removal and storage and also to allow the straight portion for certain manipulations that are difficult with the angled portion of the carry bar. The mild steel hooked portion of the carry handle performed very well with no signs of bending or failure during preliminary tests. The hand truck wheels were robust and handled different terrains with pushing forces well within prescribed limits. The crane made use of a robust and fast electric hoist. The lift time for a top panel was 12 seconds and 24 lifts and lowers were performed comfortably with single charge of a battery. No noticeable hoist performance drain after 24 lifts/lowers was seen. Many more repetitions could be performed with that battery before recharging.

The redesigned mechanical assists improved the average task energy expenditure rate for all tasks by 33% (from 6.065 Kcal/min to 4.05 Kcal/min) and the average team task energy expenditure for all tasks by 56% (from 316.4 Kcal to 138.4 Kcal). Pushing force tests was performed on the hand truck on asphalt and grass. The sustained force measured on grass was around 15.8 kg (35 lb) to 18 kg (40 lb). Although the weight of the hand truck was increased due to the heavy wheel castors, the performance was not

affected to a great extent. Further, aluminum castors of similar design can be built to reduce weight.

The Ramsey electric hoist used for the crane system was fast and energy efficient. The crane framework was strong and light for easy and fast transportation. No signs of failure were observed on the hoist body. A battery box was accommodated on the hoist frame to mount the battery to operate the hoist.

A field test is required to study and validate the results for the redesigned mechanical assists. A pallet unloading system will enable faster and fatigue free lifting of bridge parts from pallet onto the hand truck. A terrain test for the hand truck will be useful to validate the performance of the hand truck. The variables for the test would be tire pressure, load and terrain.

## APPENDIX

Included with this thesis is a DVD, which contains videos of MGB build that were important to estimate all the parameters required for the EEPP analysis and also to study the bridge build process. The videos can be opened with Windows Media Player (Microsoft Windows XP) 10 and above.

The videos that are included in the DVD are:

- 1) MGB Trainees video (MGB trainees.mpg): This shows a field test performed to evaluate the bridge build using current assists. It can be seen from the video both single and double storey bridges are constructed.
- 2) MGB Training Video (MGB training video.mpg): This video is used to train soldiers for MGB construction. It shows all the configurations of MGB. A brief 10 minutes demonstration of the entire bridge build for each configuration is shown.
- 3) Granite City USAR video (Granite City USAR.mpg): This video shows MGB construction at Granite City army reserve. It is seen from the video the parts are unloaded from pallets and are carried to the construction site and assembled with other bridge parts.

## BIBLIOGRAPHY

- [1] Sanders, Mark S., and McCormick, Ernest J., “*Human Factors in Engineering and Design*,” McGraw-Hill, 1993.
- [2] Salvendy, Gavriel., “ *Handbook of Human Factors and Ergonomics*,” John Wiley & Sons Inc, 2006.
- [3] Garg, Arun., Chaffin, D.B., and Herrin, G. D., “ Prediction of metabolic rates for manual materials handling jobs,” *AIHAJ*, 661-674, 39(8), 1978.
- [4] Waters, Thomas R., Putz-Anderson, Vern., and Garg, Arun., “*Application manual for the revised NIOSH lifting equation*,” DHHS (NIOSH) Publication NO. 94-110.
- [5] <http://www.wfel.com/products-and-services/medium-girder-bridge/technical-specification>. “MGB Technical Specification,” 25<sup>th</sup> March 2010.
- [6] TM 5-5420-212-10-1, “*Operator’s Manual, Medium Girder Bridge*,” 16<sup>th</sup> February 1993.
- [7] Roshan Shekar Kotian, “Design of mechanical assists for medium girder bridge,” Thesis, University of Missouri-Rolla, Rolla MO, 2005.
- [8] <http://www.cdc.gov/niosh/docs/97-117/eptbtr6.html#second> “Manual Materials Handling-Lifting,” 25<sup>th</sup> February 2010.
- [9] Ridyard, Dave, “Design checklists,” Applied ergonomics technology.
- [10] [http://www.darcor.com/\\_common/pdfs/WhitePaperFinal.pdf](http://www.darcor.com/_common/pdfs/WhitePaperFinal.pdf) “The ergonomics of manual material handling,” 24<sup>th</sup> January 2010.
- [11] DOD-HDBK-743A, “*Anthropometry of U.S. Military Personnel*,” 13<sup>th</sup> February 1991.
- [12] Snook, S. H., and Ciriello, V. M., “The design of manual handling tasks: revised tables of maximum acceptable weights and forces,” *Ergonomics*, 1197-213, 34(9), 1991.
- [13] <http://www.ramsey.com/winches/badger2500.html> “Badger Series,” 5<sup>th</sup> January 2009.
- [14] Davis, H.L., Faulkner, T.W., and Miller, C.I., “Work Physiology,” *Human Factors*, 157-65, 11(2), 1969.
- [15] <http://www.engin.umich.edu/dept/ioe/ENGEXP/backgnd.html> “EEPP,” January 15<sup>th</sup> 2010.



- [16] [http://www.dir.ca.gov/dosh/dosh\\_publications/mmh.pdf](http://www.dir.ca.gov/dosh/dosh_publications/mmh.pdf) "Ergonomic guidelines for manual material handling," March 22<sup>nd</sup> 2010.
- [17] Waters, Thomas R., Putz-Anderson, Vern., Garg, Arun., and Fine, Lawrence J., "Revised NIOSH equation for the design and evaluation of manual lifting tasks," *Ergonomics*, 749-776, 36(7), 1993.
- [18] Dutta. S., and Taboun. S., "Developing norms for manual carrying tasks using mechanical efficiency as the optimization criterion," *Ergonomics*, 919-943, 32(8) 1989.
- [19] Snook., S.H, and Irvine., G.H., "Psychophysical studies of physiological fatigue criteria," *Human Factors*, 291-300, 11(3), 1969.
- [20] Chaffin., D.B., "*Some effects of physical exertion*," Department of Industrial and Operations Engineering., The University of Michigan, 1972.
- [21] Niebel., B.W., "*Motion and time study*," 1982.
- [22] Thilak Inturi, "Testing and Analysis of Mechanical Assists for Medium Girder Bridge," Thesis, University of Missouri-Rolla, Rolla MO, 2006.
- [23] National Institute for Occupational Safety and Health, "Work Practices Guide for Manual Lifting," *DHHS (NIOSH) Publication No. 81-122*, 1981.

## VITA

Karthik Kumar was born on February 6, 1984 in Bangalore, India. In May 2005, he obtained a Bachelor's degree in Mechanical Engineering from Visvesvaraya Technological University, Belgaum, India. He worked for one year in Autoliv IFB India limited, Bangalore India and for another year in Tata Elxsi India Limited, Bangalore India.

In January 2008, he enrolled at the Missouri University of Science and Technology to pursue a Master's degree in Department of Mechanical Engineering under the guidance of Dr. Virgil Flanigan. He received his Master of Science Degree in Mechanical Engineering in August 2010.