Masters Theses

Student Theses and Dissertations

Summer 2011

Development and testing of chemically-based self-consolidating concrete

Mark Daniel Ezzell

Follow this and additional works at: https://scholarsmine.mst.edu/masters_theses



Part of the [Civil Engineering Commons](#)

Department:

Recommended Citation

Ezzell, Mark Daniel, "Development and testing of chemically-based self-consolidating concrete" (2011). *Masters Theses*. 5153.

https://scholarsmine.mst.edu/masters_theses/5153

This thesis is brought to you by Scholars' Mine, a service of the Missouri S&T Library and Learning Resources. This work is protected by U. S. Copyright Law. Unauthorized use including reproduction for redistribution requires the permission of the copyright holder. For more information, please contact scholarsmine@mst.edu.

DEVELOPMENT AND TESTING OF CHEMICALLY-BASED
SELF-CONSOLIDATING CONCRETE

by

MARK DANIEL EZZELL

A THESIS

Presented to the Faculty of the Graduate School of the
MISSOURI UNIVERSITY OF SCIENCE AND TECHNOLOGY

In Partial Fulfillment of the Requirements for the Degree

MASTER OF SCIENCE IN CIVIL ENGINEERING

2011

Approved by

Dr. Jeffery Volz, Advisor
Dr. John Myers
Dr. Lesley Sneed

ABSTRACT

Self-consolidating concrete (SCC) possesses several characteristics that can benefit the concrete construction industry including accelerated construction, a reduction in labor and equipment, and a reduction in construction noise through eliminating or reducing the need to vibrate the concrete. However, SCC has some potential downsides. These problems can usually be attributed to higher paste content, higher fines content, rounder aggregate, and higher water to cement (w/c) ratios used to increase the flow of the concrete. The goal of this research project was to develop a SCC that had improved material properties through the use of chemical admixtures instead of modifications to the mix proportions. After the SCC was developed, the material properties were compared to a more traditional or normal concrete (NC) mixture.

Both the SCC and NC underwent testing of fresh and hardened properties. The SCC underwent the following tests: slump flow, J-ring, L-box, and segregation column. These tests aided with mixture proportioning and optimization. After the SCC mix design was selected, material properties were tested and compared for both NC and SCC. These tests included: compressive strength, modulus of rupture, shrinkage, and shear strength. These properties were compared between the two types of concrete and also with empirical models and design code provisions.

ACKNOWLEDGEMENTS

I would like to thank my advisor, Dr. Jeffery S. Volz for his advice, guidance, and patience throughout my time as a graduate student and while working on this research project. His willingness to teach and knowledge of the material was greatly appreciated. I would also like to thank my committee members, Dr. John J. Myers and Dr. Lesley H. Sneed for their help and suggestions.

In addition to my committee I would like to thank the technicians and staff that helped in several different areas of construction and testing, particularly John Bullock, Jason Cox, Gary Abbott, and Steve Gabel. Several of my fellow graduate students also graciously donated their time to help such as Carlos Ortega, Ben Gliha, Kyle Marlay, Nichole Podhorsky, Courtney Greene, and Michael Wolfe. Without their help I am sure that much of this project would not have been possible.

Finally I would like to thank my friends and family for their support throughout my education and research. Without their encouragement and support I would not be where I am today. I am sincerely grateful to you all.

TABLE OF CONTENTS

	Page
ABSTRACT.....	iii
ACKNOWLEDGEMENTS.....	iv
LIST OF ILLUSTRATIONS.....	x
LIST OF TABLES.....	xiv
SECTION	
1. INTRODUCTION.....	1
1.1. BACKGROUND AND MOTIVATION FOR STUDY.....	1
1.2. OBJECTIVE AND SCOPE OF WORK.....	2
1.3. APPLICATION.....	2
1.4. RESEARCH PLAN.....	3
1.5. OUTLINE.....	6
2. LITERATURE REVIEW.....	8
2.1. GENERAL.....	8
2.1.1. Definition of SCC.....	8
2.1.2. Uses for SCC.....	8
2.2. MATERIAL PROPERTIES FOR SCC.....	8
2.2.1. Concrete Shrinkage.....	8
2.2.2. Shrinkage Factors.....	8
2.3. ACI COMMITTEE REPORT 237R-07.....	9
2.3.1. Filling ability.....	10
2.3.2. Stability.....	10
2.3.3. Passing ability.....	10
2.4. MIX DEVELOPMENT.....	11
2.4.1. Target Values.....	11
2.4.2. Trial Batches.....	11
2.4.3. Selecting Proportions.....	11
2.5. WATER-REDUCING ADMIXTURES.....	12
2.5.1. Classification of Water-Reducers.....	13

2.5.2. Low-Range (Regular) Water-Reducing Admixtures.	13
2.5.3. Mid-Range Water Water-Reducers.	13
2.5.4. Superplasticizers (High-Range Water-Reducers).....	13
2.5.5. Water Reduction Mechanism.	14
2.5.6. Effect on fresh concrete properties.....	14
2.5.6.1 Flowing concrete.....	14
2.5.6.2 Slump loss.....	14
2.5.6.3 Set retardation.	15
2.5.6.4 Bleeding.	15
2.5.6.5 Air entrainment.	15
2.5.7. Effect on hardened concrete properties.	15
2.5.7.1 Compressive strength.....	15
2.5.7.2 High-strength concrete.....	15
2.5.7.3 Shrinkage.	15
2.5.7.4 Creep.....	16
2.6. VISCOSITY MODIFYING ADMIXTURES.....	16
2.7. TEST METHODS.....	16
2.7.1. Slump flow test.....	17
2.7.2. Visual stability index (VSI).....	17
2.7.3. T ₅₀	17
2.7.4. J-ring.....	17
2.7.5. L-box.	18
2.7.6. Column segregation.....	18
2.8. SHEAR STRENGTH OF SCC.....	18
2.8.1. Hassan, Hossain, and Lachemi, 2010.....	18
2.8.2. Kim, Hueste, Trejo, and Cline, 2010.....	21
2.9. OPTIMIZATION OF SCC.....	24
2.10. USE OF SUPPLEMENTARY CEMENTITIOUS MATERIALS IN SCC ...	25
2.11. TEMPERATURE INFLUENCES ON SCC.....	27
2.12. SEGREGATION OF SCC.....	28
3. SCC MIX DEVELOPMENT.....	30

3.1. INTRODUCTION	30
3.2. BASE MIX DESIGN.....	30
3.3. ADDITION OF FLY ASH TO BASE MIX.....	32
3.3.1. Fly ash effects.....	32
3.3.2. Test batches.....	32
3.3.3. Test results.....	32
3.4. SCC MIX DESIGN.....	33
3.4.1. HRWR effects.....	33
3.4.2. Test batches.....	35
3.4.3. Test results.....	35
3.4.4. VMA effects.....	36
3.4.5. Test batches.....	36
3.4.6. Test results.....	36
3.4.7. Final Mix Design.....	36
4. MATERIAL TESTING PROGRAM.....	38
4.1. INTRODUCTION	38
4.1.1. Casting.....	38
4.1.2. Curing Conditions.....	38
4.2. FRESH CONCRETE TESTING PROGRAM.....	39
4.2.1. Density.....	39
4.2.2. Air content.....	40
4.2.3. Slump flow.....	40
4.2.4. Passing ability.....	44
4.2.5. Static Segregation.....	45
4.3. HARDENED CONCRETE TESTING PROGRAM.....	47
4.3.1. Compression testing.....	47
4.3.1. Results.....	49
4.3.2. Conclusions.....	50
4.3.3. Modulus of rupture.....	52
4.3.4. Results.....	52
4.3.5. Conclusions.....	52

4.4. CONCLUSIONS.....	56
5. SHRINKAGE.....	59
5.1. METHODOLOGY	59
5.2. RESULTS	61
5.3. DATA ANALYSIS AND INTERPRETATION	63
5.4. CONCLUSIONS.....	69
6. FULL-SCALE BEAM SHEAR TESTS.....	72
6.1. INTRODUCTION	72
6.2. SPECIMEN DESIGN	72
6.3. SPECIMEN CONSTRUCTION.....	80
6.4. SPECIMEN INSTRUMENTATION AND TEST SETUP	89
6.4.1. Specimen instrumentation.	89
6.4.2. Test setup.....	92
6.5. MATERIAL STRENGTH TESTING AND RESULTS	95
6.5.1. Tensile strength of reinforcing steel.....	95
6.5.2. Compressive Strength of Concrete.....	95
6.6. TEST RESULTS.....	97
6.7. DATA ANALYSIS AND INTERPRETATION	115
6.8. CONCLUSIONS.....	124
7. FINDINGS, CONCLUSIONS, AND RECOMMENDATIONS	126
7.1. INTRODUCTION	126
7.2. FINDINGS.....	126
7.2.1. Fresh Concrete Property Tests.	126
7.2.2. Hardened Concrete Property Tests.....	127
7.2.3. Shrinkage Testing.....	128
7.2.4. Full-Scale Beam Shear Tests.....	129
7.3. CONCLUSIONS.....	130
7.4. RECOMMENDATIONS.....	131
APPENDICES	
A. MATERIAL DATA SHEETS.....	132
B. SHRINKAGE PLOTS.....	139

BIBLIOGRAPHY..... 143
VITA147

LIST OF ILLUSTRATIONS

	Page
Figure 3.1. Slumps at Different Fly Ash Replacements	34
Figure 3.2. Concrete Compressive Strength With Fly Ash Replacement.....	34
Figure 4.1. Raising the Mold During Slump Flow Test	41
Figure 4.2. Measure Concrete Diameter During Slump Flow Test	42
Figure 4.3. J-Ring Test.....	44
Figure 4.4. Concrete Compression Testing.....	49
Figure 4.5. Concrete Compressive Strength With Fly Ash Replacement.....	50
Figure 4.6. Compressive Strength vs. Time.....	51
Figure 4.7. Modulus of Rupture.....	53
Figure 4.8. Modulus of Rupture.....	54
Figure 4.9. Modulus of Rupture After Testing	54
Figure 4.10. Modulus of Rupture After Testing	55
Figure 4.11. Modulus of Rupture.....	55
Figure 5.1. Shrinkage Specimens and DEMEC Locations	59
Figure 5.2. Typical Shrinkage Specimen	60
Figure 5.3. Concrete Shrinkage Specimens	61
Figure 5.4. Shrinkage Plot	63
Figure 5.5. Shrinkage Plot With Standard Deviations.....	64
Figure 5.6. Concrete Shrinkage Compared to ACI 209R Model.....	69
Figure 5.7. Concrete Shrinkage Compared to Bazant-Baweja B3 Model	70
Figure 5.8. Concrete Shrinkage Compared to GL2000 Model	70
Figure 6.1. Loading Condition for Full-Scale Beam Shear Tests.....	74
Figure 6.2. Steel Reinforcement Location	78
Figure 6.3. Shear Reinforcement With No Stirrups.....	78
Figure 6.4. Shear Reinforcement With 7 in. Stirrup Spacing	79
Figure 6.5. Shear Reinforcement With 5 in. Stirrup Spacing	79
Figure 6.6. Reinforcement Cages.....	82
Figure 6.7. Strain Gages.....	82

Figure 6.8. Forms Prior to Concrete Placement.....	84
Figure 6.9. Initial Slump Taken	85
Figure 6.10. Filling Concrete Bucket.....	85
Figure 6.11. Placing Concrete.....	86
Figure 6.12. Vibrating Concrete	86
Figure 6.13. Finishing NC	87
Figure 6.14. Addition of Chemical Admixtures	87
Figure 6.15. Placing SCC.....	88
Figure 6.16. Slump Flow	88
Figure 6.17. Concrete Placement Operations	89
Figure 6.18. Strain Gage Location – Beam With No Stirrups	90
Figure 6.19. Strain Gage Locations – Beam With 7 in. Stirrup Spacing.....	90
Figure 6.20. Strain Gage Locations – Beam With 5 in. Stirrup Spacing.....	90
Figure 6.21. LVDT	91
Figure 6.22. Data Acquisition System	92
Figure 6.23. Loading Locations for Full-Scale Shear Specimens	93
Figure 6.24. Shear Test Setup – Front View.....	94
Figure 6.25. Shear Test Setup – Side View	94
Figure 6.26. Load vs. Deflection Plot for NC – No Stirrups	98
Figure 6.27. Load vs. Deflection Plot for NC – 7 in. Spaced Stirrups	98
Figure 6.28. Load vs. Deflection Plot for NC – 5-in. Spaced Stirrups	99
Figure 6.29. Load vs. Deflection Plot for SCC – No Stirrups	99
Figure 6.30. Load vs. Deflection Plot for SCC – 7 in. Spaced Stirrups	100
Figure 6.31. Load vs. Deflection Plot for SCC – 5 in. Spaced Stirrups	100
Figure 6.32. Concrete Shear Strength Plot.....	103
Figure 6.33. Typical Stirrup Strain Plot as a Function of Load.....	104
Figure 6.34. Typical Crack Pattern for NC – Stage 1	104
Figure 6.35. Typical Crack Pattern for NC – Stage 2.....	105
Figure 6.36. Typical Crack Pattern for NC – Stage 3.....	105
Figure 6.37. Typical Crack Pattern for NC – Stage 4.....	106
Figure 6.38. Typical Crack Pattern for SCC – Stage 1	106

Figure 6.39. Typical Crack Pattern for SCC – Stage 2.....	107
Figure 6.40. Typical Crack Pattern for SCC – Stage 3.....	107
Figure 6.41. Typical Crack Pattern for SCC – Stage 4.....	108
Figure 6.42. Typical Crack Pattern for SCC – Stage 5.....	108
Figure 6.43. Control-NS-1 Beam at Failure.....	109
Figure 6.44. Control-NS-2 Beam at Failure.....	109
Figure 6.45. Control-NS-3 Beam at Failure.....	109
Figure 6.46. Control-7-1 Beam at Failure.....	110
Figure 6.47. Control-7-2 Beam at Failure.....	110
Figure 6.48. Control-7-3 Beam at Failure.....	110
Figure 6.49. Control-5-1 Beam at Failure.....	111
Figure 6.50. Control-5-2 Beam at Failure.....	111
Figure 6.51. Control-5-3 Beam at Failure.....	111
Figure 6.52. SCC-NS-1 Beam at Failure	112
Figure 6.53. SCC-NS-2 Beam at Failure	112
Figure 6.54. SCC-NS-3 Beam at Failure	112
Figure 6.55. SCC-7-1 Beam at Failure	113
Figure 6.56. SCC-7-2 Beam at Failure	113
Figure 6.57. SCC-7-3 Beam at Failure	113
Figure 6.58. SCC-5-1 Beam at Failure	114
Figure 6.59. SCC-5-2 Beam at Failure	114
Figure 6.60. SCC-5-3 Beam at Failure	114
Figure 6.61. Concrete Shear Strength.....	120
Figure 6.62. Normalized Concrete Shear Strength	122
Figure 6.63. Comparison of Current Test Results with Previous Test Data Collected by Tureyen and Frosch (2003).....	122
Figure 6.64. V_u/V_d Plot.....	123
Figure B.1. Concrete Shrinkage.....	140
Figure B.2. Concrete Shrinkage.....	140
Figure B.3. Concrete Shrinkage Compared to ACI 209R-92 Model.....	141
Figure B.4. Concrete Shrinkage Compared to Bazant-Baweja B3 Model	141

Figure B.5. Concrete Shrinkage Compared to GL2000 Model 142

LIST OF TABLES

	Page
Table 3.1. Fly Ash Replacement Trial Batches	33
Table 3.2. HRWR Trial Batches	35
Table 3.3. VMA Trial Batches.....	37
Table 3.4. Final Mix Design	37
Table 4.1. Summary of Fresh Concrete Testing Program	39
Table 4.2. HRWR Dosages	43
Table 4.3. VMA Dosages.....	46
Table 4.4. Static Segregation Data.....	47
Table 4.5. Summary of Hardened Concrete Testing Program.....	48
Table 4.6. Modulus of Rupture	53
Table 5.1. NC Shrinkage Strain.	62
Table 5.2. FA Shrinkage Strain.....	62
Table 5.3. SCC Shrinkage Strain	62
Table 5.4. NC Shrinkage Strain.	65
Table 5.5. FA Shrinkage Strain.....	65
Table 5.6. SCC Shrinkage Strain	66
Table 6.1. Full Scale Shear Test Matrix	77
Table 6.2. Final SCC Mix Design per Cubic Yard	79
Table 6.3. Final NC Mix Design per Cubic Yard	80
Table 6.4. Tensile Strength of Steel.....	96
Table 6.5. Concrete Compressive Strength.....	97
Table 6.6. Tested Shear Strength	102
Table 6.7. Vu and Vd Values.....	103
Table 6.8. Calculation of V_s	116
Table 6.9. V_{test} / V_{code}	117
Table 6.10. Shear Strength From Concrete.....	119
Table 6.11. Tested Shear Strength Comparison.....	121
Table 6.12. V_u/V_d	124

1. INTRODUCTION

1.1. BACKGROUND AND MOTIVATION FOR STUDY

Self-consolidating concrete (SCC) is one of the concrete industry's latest developments; it is defined as a concrete that spreads easily under its own weight while still resisting segregation. SCC has three main subsets: self-compacting concrete, self-placing concrete, and self-leveling concrete, all of which tout many positive traits that can translate to economic and technological benefits for the end user. Some of these benefits include accelerated construction, a reduction in labor and equipment, and a reduction in construction noise through eliminating or reducing the need to vibrate the concrete. Furthermore, SCC provides the ability to achieve good compaction even in areas that have high steel congestion, and this ability is independent of the skill of a vibrating crew, providing better quality control of the end product. While these are impressive benefits, SCC is not completely without problems. The use of SCC has also brought about two significant concerns that must be addressed or taken into account when designing reinforced concrete with this material: shear strength and shrinkage.

The first concern is that SCC has a lower shear resistance than normal concrete (NC). This is primarily due to the way that SCC has traditionally been produced. By reducing the amount of coarse aggregate and selecting an aggregate that is more rounded in nature, designers are able to produce a concrete that is much more flowable. While this provides benefits during concrete placement, it can negatively impact the hardened properties of the concrete, such as the concrete shear strength. When comparing a rounded aggregate to an angular aggregate, there is the potential for a reduced amount of aggregate interlock under loading. Rheology, which is related to aggregate diameter and spacing, also affects shear strength, and there is a significant difference between SCC and NC in this area.

Shrinkage of SCC is also a concern. Factors that typically contribute to shrinkage are higher paste contents, higher water/cement (w/c) ratios, and the types and amounts of admixtures used within the concrete. SCC generally includes all of these traits compared to traditional concrete mixes.

Since SCC is still relatively new to the industry, there is still a significant amount of research that needs to be conducted. The outlook for SCC seems bright in areas such as precast or prestressed operations but some users are still hesitant to embrace the material for the concerns mentioned above.

1.2. OBJECTIVE AND SCOPE OF WORK

The objective of this project was to develop an SCC mixture using materials local to central Missouri and then test and compare the fresh and hardened properties to a control NC mixture. Different types and amounts of chemical admixtures were used that allowed for more optimized coarse aggregate properties. Keeping in mind the typical SCC factors that can negatively affect shear strength, the highest aggregate content with angular shapes were used while still maintaining a highly flowable mix. This result required a chemically-based approach to SCC mix development. The mixes were then tested in the plastic and hardened states including shear strength and shrinkage behavior.

The following scope of work was implemented in order to achieve the project's objective: (1) review applicable literature; (2) develop a research plan; (3) develop and optimize SCC and NC mix designs for testing; (4) perform material tests on both fresh and hardened concrete specimens; (5) design, construct, and test full-scale shear testing specimens; (6) analyze results and prepare this theses in order to document the discovery of information obtained during this research study.

1.3. APPLICATION

When SCC was first developed, the flowability was increased by increasing w/c ratios, increasing paste contents, and using rounder aggregates. These can all contribute to a reduction in shear strength. Since the early days of SCC, admixtures have made great strides and it is possible to create SCC without taking all of these shear strength reducing measures. If an SCC design can be created using a lower w/c ratio, lower paste content, a more angular aggregate, or some combination of the three, when compared to early SCC mix designs, then it could be possible that the effect on shear strength will be negligible or at least smaller than once feared. This would be good news for areas such as the precast or prestressed industries.

The prestressing industry in particular will be concerned with the amount of shrinkage that SCC experiences compared to NC. In many prestressed applications, steel congestion can be a problem; and many plants are already required to use highly flowable mixes to ensure that concrete passes around all of the prestressing strands. If SCC experiences significantly more shrinkage it will lead to significantly higher prestress losses. With the addition of new chemical admixtures it becomes possible to increase the amount of coarse aggregate, reduce the w/c ratio, and maintain the flowability of the SCC all while keeping the shear strength and shrinkage on par with NC.

1.4. RESEARCH PLAN

The proposed research plan included a description of eight (8) tasks necessary to successfully complete the study. They are as follows:

Task 1: Review applicable literature. In order to better understand the topic it was necessary to become familiar with previous research. This indicated the test methods that would be most beneficial and gave a basis for comparison of results from this study to others. Research programs that studied the effects of aggregate size and shape on concrete shear strength, effects of admixtures on workability and finishability, and factors that can effect concrete shrinkage were of particular interest in this area.

Task 2: Perform aggregate material testing. Before mix design could begin, aggregates were obtained locally for use in the concrete. Standard tests were performed on the aggregates, both fine and coarse, to determine their properties. These tests included: specific gravity, absorption, unit weight, sieve analysis, absorption, total and surface moisture content, and organic impurities. These material properties were used along with ACI 211.1-92 to create the initial normal concrete mix design.

Task 3: Evaluate the effects of fly ash on the fresh and hardened concrete. It is generally accepted that the addition of fly ash to concrete will lead to an increase in slump and workability. Since the objective of this research was to create a self-consolidating concrete with a very high slump and workability, the addition of fly ash was a logical choice. Fly ash is a waste product from burning coal during electricity generation, which makes it an environmentally friendly product and its cost is lower than cement or chemical admixtures. If a moderate increase in slump can be achieved without

a significant decrease in strength, it would be possible that admixture dosages could be decreased, reducing the cost. As a part of this task, both fresh and hardened properties of concrete were tested with four different amounts of fly ash replacement. This allowed for an optimization of the amount of cement that would be replaced with fly ash by balancing the slump and workability increases in the fresh state with the short term retardation in compressive strength gain.

Task 4: Evaluate the use of different types and brands of admixtures. In order to maintain the shear strength of the self-consolidating concrete being developed, the coarse aggregate content was kept higher than normally seen in other self-consolidating concrete mixes. This approach will lead to a decrease in the slump of the concrete so the use of chemical admixtures became necessary. It was determined that three chemical admixtures would be used: air-entraining admixture, high-range water reducing admixture, and a viscosity-modifying admixture. By increasing the air content in the concrete, the durability of the concrete is increased as well as a slight increase in slump. The high-range water reducing admixture provided a significant increase in the slump of the concrete making it flowable without increasing the w/c ratio to a point that compressive strength drops too low. The viscosity-modifying admixture prevented excessive segregation in the fresh state, which can be an issue with a highly flowable concrete. With the manufacturer's recommendations, and after testing was completed in the lab, the types and dosages of the required admixtures were found and a mix design was developed for the self-consolidating concrete.

Task 5: Produce and evaluate test batches of concrete. As a starting point, ACI 211.1-92 was used to develop an initial mix design. Assumptions were made that the desired slump would be approximately 4 inches (101 mm) and the air content would be approximately 4 percent. Information about the aggregate discovered during Task 2 was also used at this time. This initial concrete was produced and evaluated both in the fresh and hardened states. Changes were then made to the mix design based on these results and retested. Some of these changes included modifying the w/c ratio, increasing or decreasing the aggregate content, and testing different dosages of air-entraining admixtures to obtain the desired air content. After the NC had been optimized, work began to develop the SCC. This process began by testing different types and amounts of

high-range water reducers and viscosity modifying admixtures. The desired product had to have a high flowability without a high potential for segregation. This meant balancing the amounts of the two admixtures that would be used. Similar testing was performed on the SCC as the NC in the hardened state; however, because of the rheology of the material, traditional fresh concrete testing was not an option. To test the SCC in its fresh state, testing apparatuses developed especially for the material were used. Much like the NC, this information was used to optimize the mix design as well as the admixture dosages to obtain an optimized SCC.

Task 6: Perform shrinkage testing. One concern with SCC was the amount of shrinkage that the concrete would experience. Many times this increase in shrinkage can be attributed to the increase in paste content; since the paste shrinks as it cures, it seems reasonable that if the paste content is increased to improve flowability and create an SCC, the overall concrete shrinkage would also increase. The purpose of the shrinkage testing in this case was to see if keeping the aggregate contents the same as a traditional concrete and improving the flowability through the use of admixtures would decrease the shrinkage experienced.

To study the concrete shrinkage, cylindrical specimens measuring 4 inches (101 mm) in diameter and 24 inches (609 mm) in length were produced using NC, SCC, and a NC with a thirty percent replacement of cement with fly ash referred to as the fly ash concrete (FA). Four specimens were created for each type of concrete and each concrete specimen had three rows of DEMEC points for a total of nine readings per specimen. These readings were averaged to obtain an overall shrinkage value for the concrete. Initially readings were taken every day to capture the largest changes in length but as time progressed and shrinkage happened more slowly, readings were taken less frequently. Shrinkage values were then plotted over the time period that readings were taken to compare the three concrete types. This allowed for a comparison of NC to SCC. Since the FA could also be compared to the NC and SCC it could be seen if any changes in shrinkage were due to the admixtures, the fly ash, or a combination of the two.

Task 7: Perform shear testing. In addition to the potential for increased shrinkage, SCC can also have a decreased shear strength when compared to NC. As with shrinkage, this can typically be attributed to the increase in the paste content and the types of

aggregate that are used. If the aggregate contents are decreased and a rounder aggregate is used to improve the flowability of the concrete, there is less aggregate interlock to provide shear strength. The reasoning for the chemical admixtures was to produce SCC with a higher content of a more angular-shaped aggregate.

In order to compare the shear strength of the NC and SCC, full scale beams were manufactured to be tested in a third point loading configuration. These beams were designed to fail in shear by increasing the flexural reinforcement. Three stirrup designs were also created: no stirrups, the minimum amount required by ACI, and slightly more than the minimum amount required by ACI. Strain gages were applied to the stirrups and to the flexural reinforcement to ensure that the steel was yielding, and the maximum load applied to the beam was also recorded and used to calculate the strength of the beams.

Task 8: At the conclusion of testing, information was gathered and used to develop findings, conclusions, and recommendations to document the discovery of information obtained during this research project. The strength of the concrete in shear and the shrinkage of the SCC compared to the NC was used by researchers to evaluate the overall performance of the concrete. The data will also help to draw conclusions and recommend future studies on the product. This thesis will include a literature review, a description of testing that was completed, and a conclusions and recommendations section.

1.5. OUTLINE

This thesis includes seven chapters and two appendices. This section will discuss the information that will be presented in more detail throughout this document.

Chapter 1 includes background information about SCC and the reasoning for performing this research. It also discusses the scope of work that was done and the work plan that was followed.

Chapter 2 includes information from previous research performed on SCC to date. This section includes material properties and mix proportioning of SCC, a description of typical admixtures used, test methods employed, and optimization of the material.

Chapter 3 describes the process followed to develop the SCC mix design used throughout the research project.

Chapter 4 includes information about the material testing program. The steps that were followed to determine the fresh and hardened concrete properties are discussed in this chapter.

Chapter 5 presents information found from shrinkage testing. The process of casting the specimens, de-molding, and taking data is described as well as presenting results and conclusions found.

Chapter 6 describes the fabrication process of the shear specimens as well as the results of the full-scale shear tests that were performed. It describes the process from bending the rebar to placement and finishing of the concrete as well as presenting results and conclusions found.

Chapter 7 includes findings, conclusions, and recommendations based on the research performed.

Appendix A includes material data sheets for the chemical admixtures used during testing.

Appendix B includes shrinkage plots for concrete specimens.

2. LITERATURE REVIEW

2.1. GENERAL

2.1.1. Definition of SCC. SCC is defined as a highly flowable concrete that resists segregation; it has the ability to fill formwork and encapsulate reinforcement with little or no mechanical consolidation while still maintaining adequate viscosity to resist segregation. Its rheology is characterized by a low yield stress making it easy to deform and a moderate viscosity in its plastic state to maintain a proper, homogenous suspension of solids (ACI 237, 2007).

2.1.2. Uses for SCC. Initially, SCC was developed to ensure that proper consolidation was achieved in areas where durability and service life were a concern. Some of these areas were cast sections with limited access but still highly congested reinforcement such as a tunnel lining section or concrete filled tubular columns. More recently SCC has been used for concrete repair applications such as bridge abutments and pier caps, parking garages, and retaining walls in Canada and Switzerland. North America has also seen an increase in the amount of the SCC especially in the precast industry. To provide design assistance and to study this emerging technology, the American Concrete Institute (ACI) has created ACI Committee 237 and the information covered in Sections 2.1 through 2.4.3 is from their Emerging Technology Series on SCC.

2.2. MATERIAL PROPERTIES FOR SCC

2.2.1. Concrete Shrinkage Shrinkage is defined as the decrease in the volume of the cement. It is composed of drying shrinkage, autogenous shrinkage, and carbonation. The main component is drying shrinkage and, as the name suggests, the volume decrease in the cement is due to moisture loss from the concrete.

2.2.2. Shrinkage Factors Factors that contribute to shrinkage are the w/cm ratio, curing conditions, and the volume to surface ratio of the concrete. As the w/cm ratio increases there is more water to dissipate from the concrete matrix leading to more shrinkage. The type and duration of curing can also heavily affect shrinkage. If the relative humidity surrounding the specimen increases, the shrinkage will decrease. Depending on the type of curing, either active or passive, a different amount of relative

humidity can be provided to prevent shrinkage. Finally, specimens that have a larger shape and overall higher volume to surface ratio, will entrap more water in the concrete matrix and decrease shrinkage.

Current research has shown that shrinkage of SCC can be more or less than that of normal concrete (NC) depending on the way that the concrete was developed. Since drying is the largest contributor to overall shrinkage, the w/cm ratio of the concrete is very important. If the amount of free water is increased to provide improved flowability, then it is likely that there will be an increase in the amount of shrinkage in the concrete. If, however, the w/cm is kept the same but the flowability of the concrete is increased through the use of chemical admixtures or aggregate size and shape modifications, then it is likely that the shrinkage will remain the same as that of normal concrete.

2.3. ACI COMMITTEE REPORT 237R-07

While the hardened properties of SCC compared to those found in NC have been shown to be significantly different, it is the properties during the fresh, plastic state that really differentiate the two materials. To objectively evaluate an SCC mixture, there are two different processes. The first is to evaluate the rheological properties of the SCC, and the second is to evaluate the properties using the more practical field-related testing equipment. The later is the easier and more widely know method for testing SCC. There are three properties that can be determined through field relating tests that will be discussed: stability, filling ability, and passing ability. These properties are all influenced by and tied to the rheological properties of the concrete. To develop a SCC mix design that will work in a particular application, the designer must have an adequate knowledge of these three concrete characteristics and know the type of application for which the concrete will be used so that the concrete is suitable for the job.

The desired stability, filling ability, and passing ability needed by a concrete mix will always depend on the application. The three are equally important and have an effect, to some extent, on the others. When working with SCC, there should be a clear understanding of exactly what each characteristic means and its importance in different situations.

2.3.1. Filling ability. Filling ability is defined as the ability of SCC to flow and fill in completely all the spaces within a set of formwork. It is affected by the fluidity and the viscosity of the concrete. If the fluidity of the concrete increases or viscosity decreases, then the filling ability would likely increase; however, as the fluidity and the viscosity change, so will the rheology, which will likely alter the stability of the concrete as well.

2.3.2. Stability. Stability is defined as the concrete's ability to maintain a homogeneous distribution of its constituents during placement and hardening. Since these are two very different types of applications, there are two types of stability characteristics equally important to SCC: dynamic and static stability. While SCC is in its plastic state, the typical stability issue is the settlement of the coarse aggregate to the bottom of the form. Workers may also find that they see excess bleeding or surface settlement after the casting is completed but before the concrete has set. These are all static stability issues and can be combated in some cases by using Viscosity Modifying Admixtures (VMA). A VMA is an admixture used to improve the rheological properties of the concrete in its plastic state so that it can reduce the risk of segregation or washout. The second stability issue, dynamic stability, refers to the concrete's ability to remain homogenous and resist separation during placement in the formwork. This can be an issue if the concrete is flowing through closely spaced obstacles or narrow spaces. This should also be considered when selecting the type of transportation method and whether there is agitation or not.

2.3.3. Passing ability. Finally, passing ability is the ability of the concrete to pass among obstacles such as congested steel or narrow spaces in the formwork. Should the concrete have segregation issues and the coarse aggregate build up in one of these areas, a blockage could be experienced, reducing the passing ability of the concrete. Passing ability is a measure of the flowability of the concrete in a confined situation. It should not be confused with filling ability, which is the flowability of the concrete in an unconfined situation.

In order for a designer to find the properties discussed above it is necessary to produce trial batches of concrete and to quantify the material's filling ability, passing

ability, and stability. To objectively and effectively find these properties, test methods have been developed and at this time are under refinement by ASTM.

2.4. MIX DEVELOPMENT

2.4.1. Target Values The first step to creating a SCC mix design is to determine the slump flow that will be required for the particular application. Generally, a mix designer should target the lowest slump flow that will provide adequate passability so as to reduce problems associated with segregation or instability. Tables found in ACI 237R-11 can assist with the selection of an appropriate slump flow target. To begin, the mix designer should rank each of the member characteristics as low, medium, or high. The shaded boxes show areas that should be avoided. For example, if there will be a low placement energy, it is recommended that the concrete have a slump flow of at least 26 inches. With the placement energy low, the concrete will need to have a high filling ability so that it will be able to fill the forms completely without the assistance of vibration.

2.4.2. Trial Batches Once the target slump flow is found, designers can move on to conducting trial mixtures using the materials that will be used on the project. Once the concrete is batched, the slump flow should be checked again and the other fresh SCC properties, passing ability and stability, should be determined. Once they have all been determined, the slump flow can be compared to passing ability and stability and a relationship between them can then be established. This will usually prove useful because it will allow for less frequent testing of stability in the field.

2.4.3. Selecting Proportions ACI document 237R limits its discussion to SCC produced using conventional materials and production methods. SCC is a high performance concrete in the plastic state with a much higher level of workability and self-consolidation. These attributes are characterized by the concrete's filling ability, passing ability, and stability. All of these attributes should be present before it can be considered SCC. To achieve these properties and to optimize them for the concrete's intended purpose, the application and the placement technique should be taken into account. One example might be that concrete for a footing could have a higher coarse aggregate content than concrete to be placed in a column with congested steel reinforcement. The

designer could take advantage of the benefits of a higher aggregate content if a large slump flow was not required. In a situation where passability was not of the highest concern, it might not be a problem.

When developing a SCC mix design, the ACI 237R guide will supplement the standard practice for selecting proportions for concrete mixture proportions found in ACI 211.1. There are three different approaches that are typically followed when creating an SCC mixture. The first is to increase the powder content and apply a high range water reducing (HRWR) admixture. The higher powder content promotes stability while the HRWR promotes flowability. The second is to keep the coarse aggregate content higher and the powder content lower from the first and achieve flowability with a high dosage of chemical admixtures. This could be beneficial if strength, either shear or compressive, might be an issue. It can, however, lead to segregation problems, so in addition to the HRWR a viscosity modifying admixture (VMA) can be applied. The third method is a combination of the two with a moderate powder content and a moderate VMA dosage. The approach that the designer should take is once again based on the specific application.

2.5. WATER-REDUCING ADMIXTURES

In many cases where a high filling ability is required, mix designers will turn to a water-reducing admixture. As the name indicates, this admixture lowers the water that is required to attain a given slump, or it reduces the water demand of the concrete. This ability is advantages in several different ways. The first would be to maintain the same slump but decrease the water content. This would result in a general improvement in strength, impermeability, and durability of the concrete. Alternatively, if cost was an issue, the w/c ratio can be kept the same but the amount of cement can be decreased. With less cement, which is the highest priced ingredient in concrete, the overall cost of the concrete can be decreased and the water-reducing admixture can maintain the same workability. This change may be made for these economic reasons or it may be made for technical reasons. If heat of hydration is a concern, reducing the amount of cement will help to lower the concrete temperature. Finally, water reducing admixtures can be used to help facilitate difficult placements such as intricately detailed forms of highly

congested steel. If a water-reducing admixture is added to a concrete and the water and cement contents are kept the same, the slump will increase as well as workability and finishability.

2.5.1. Classification of Water-Reducers. Water-reducers are marketed by their manufactures in three different categories: low, mid, and high-range. The advantage of using a mid or high-range water-reducer is that it will allow for improved performance and increased slump without negatively affecting the setting times or air entrainment.

2.5.2. Low-Range (Regular) Water-Reducing Admixtures. An admixture may be classified as a Type A water-reducing admixture according to ASTM C 494 if it reduces water requirements by at least 5%. ASTM C 494 is a performance specification that sets the minimum for the decrease in water content required to achieve the same slump as a control mix while maintaining other properties within the specified limits. These water-reducers will achieve reductions of 5 to 10% in water requirements. The actual water reduction is based on several factors: type of admixture, cement fineness, mix proportions, temperature of concrete, and time of addition.

2.5.3. Mid-Range Water Water-Reducers. In an effort to provide a wide range of products that can work well in any application, admixture companies now offer formulations that work between conventional concrete and flowing concrete. This is generally defined as concrete that has a slump between 5 and 8 in. (125 and 200 mm) These are called mid-range water-reducing admixtures, however, this classification is not recognized by ASTM C 494.

2.5.4. Superplasticizers (High-Range Water-Reducers). In applications where flowing concrete or a much higher amount of water reduction is required, a high range water-reducing agent can be used. To be classified as a high-range water-reducing admixture according to ASTM C 494, a water reduction must be achieved of at least 12-30%. In some cases it may be used to achieve slumps greater than 8.5 in. (190 mm), in which case it must conform to ASTM C 1017, which sets a performance limit in terms of an increase in slump. Generally, most commercial products will adhere to both requirements but having both specifications allows for specifying specific performance criteria in terms of the plasticizing effects.

High-range water-reducers are frequently used in the production of high-strength concrete where w/c ratios of well below 0.40 and sufficient workability is required. In some cases, such as in the production of SCC, these admixtures can be used without a reduction in water to produce concrete with very high slumps. At these slumps, the concrete flows like liquid and fills forms efficiently, requiring little or no vibration.

2.5.5. Water Reduction Mechanism. Water-reducing admixtures are composed of negatively charged organic molecules that when added into a concrete mixture absorb at the solid-water interface. In a concrete mixture, solid particles will have charges on their faces, these may be positive, negative, or both. As the particles move past each other during mixing, electrostatic attractions cause adjacent particles to flocculate. As the particles move together, they trap a considerable amount of water leaving less water to reduce the viscosity of the concrete. The water-reducing admixture works by neutralizing the surface charges and causing all the particles to have the same charge. This causes the particles to repel each other and disperse the water into the paste. This allows the water to work harder in the mixture.

2.5.6. Effect on fresh concrete properties.

2.5.6.1 Flowing concrete. Improved flowability can be advantageous in several different situations such as difficult placements, areas where adequate vibration cannot be achieved, or even to improve the ease in placement. With the use of a high-range water-reducer, higher slumps can be achieved with mix proportions that are closer to a normal concrete. This would not be easily achieved with conventional water reducers without using oversanded mixes with high cement contents. This type of concrete is suited for use in tremie placements, rapid pumping of concrete, and for SCC.

2.5.6.2 Slump loss. While the loss of slump can be a problem with any high-slump concrete, it can be aggravated with the use of a high-range water-reducer. To combat this problem, a second dose of the admixture can be added or the addition of the admixture can be done immediately before placement. It should be noted that if repeat additions are to be made, adequate time for mixing should be allowed for proper blending. In extreme cases flash setting may occur but this can usually be alleviated by delaying the addition of the admixture.

2.5.6.3 Set retardation. Regular and some mid-range water-reducing admixtures can act as retarding admixtures. It is recommended that if a faster strength gain is required, an accelerator be added to balance the effects of the water-reducer. In some cases it has been noted that some non-retarding formulations can cause retardation if the curing temperature is low enough.

2.5.6.4 Bleeding. Water-reducers that are based on hydroxycarboxylic acids tend to increase bleeding. While these admixtures are formulated to improve concrete workability, they may not improve the cohesiveness. To properly design a flowing concrete, overdosing must be avoided as it can lead to bleeding and segregation.

2.5.6.5 Air entrainment. Whenever a regular water-reducing admixture is used, less air-entraining admixture will be required. This is because the water-reducing admixture coats the cement particles to reduce flocculation; this prevents the air-entraining admixture from being absorbed into the cement particles and makes the admixture wholly available to act at the air-water interface. This is not the case with a high-range water-reducer. These have air-detraining properties and to compensate for this, more air-entraining agent must be added to obtain the same air content as before the high-range water-reducer was added.

2.5.7. Effect on hardened concrete properties.

2.5.7.1 Compressive strength. With the addition of water-reducing admixtures, an increase of approximately 25% in compressive strength can be seen over decreasing the w/c ratio alone. These effects can be seen within 24 hours if the effects of retardation do not occur. This increase in strength is due to the evenly dispersed particles creating a more uniform microstructure. Some call this increasing the efficiency of the cement.

2.5.7.2 High-strength concrete. High strengths can be achieved when the w/c ratio is decreased below 0.40, but this cannot be done economically if the cement content is raised too high and excessive heat is produced. The amount of cement must be kept at normal levels with water-reducers maintaining the same slump.

2.5.7.3 Shrinkage. It has been stated that water-reducing admixtures increase the drying shrinkage of concrete. Data to this effect has generally been conflicting and variables such as cement type and the particular admixture make it difficult to make

general conclusions on the subject. It is often noted that the rate of shrinkage is increased, however, after 90 days there is little difference in the shrinkage of concrete made with a water-reducer to that of a control concrete.

2.5.7.4 Creep. As with shrinkage, there have been reports that increases in creep have been measured but the data is still unclear and there are significant differences between types and brands of admixtures. If creep values are critical, it is generally recommended that testing be performed to assess the effects of the mix design with the materials and admixtures that will be used.

2.6. VISCOSITY MODIFYING ADMIXTURES

Viscosity modifying admixtures are water-soluble polymers with a high molecular weight. They are used to increase the viscosity of water. Since the water is mixed within the concrete, this increases the cohesiveness of fresh concrete and reduces the tendency to bleed and segregate. Viscosity modifying admixtures are useful for gap-graded mixes where large particles tend to segregate and sink within the mixture or when improved lubricating properties are desired.

Materials that are commonly used to create viscosity-modifying admixtures are polyethylene oxides, cellulose ethers, alginates, natural gums, and polyacrylamides or polyvinyl alcohol.

In general an SCC that has a given w/cm ratio and low dosage of HRWRA will exhibit a better static stability when a VMA is incorporated into the mix design. Typically a VMA is not necessary in an SCC with a low w/cm ratio and/or high binder content because it will tend to have proper stability already. If an SCC is designed to have a relatively high w/cm ratio and/or low binder content a VMA should be added to ensure adequate stability and robustness.

2.7. TEST METHODS

The characteristics that designers and finishers will be most interested in with SCC will be the concrete's ability to fill a mold, resist segregation, flow through congested areas or obstacles without segregation, and finishability. To that end, there

have been six tests that have been developed, specifically for SCC, to determine these characteristics.

2.7.1. Slump flow test. The slump flow test is a common procedure that can be executed quickly and easily at a concrete plant or jobsite to find the free-flow properties of the concrete in the absence of any obstructions. The procedure follows ASTM C 143/C 143M (2010). The concrete is placed in an inverted concrete slump cone in one lift without any means of consolidation. The mold is then raised and the concrete is allowed to flow out of the bottom of the cone. Two diameters are then measured, perpendicular to each other, across the concrete. The average is then recorded as the concrete's slump flow. The slump flow can be compared to the filling potential of the concrete.

2.7.2. Visual stability index (VSI). After completion of the slump flow test, a visual stability index reading can be performed on the concrete from the slump flow test. This index is intended to provide a quick measurement of the concrete's stability. After the slump flow is completed and diameters have been measured, a visual observation of the concrete spread is noted and a VSI number of 0, 1, 2, or 3 is assigned. A reading of 0 or 1 should indicate that the concrete is stable, while a reading of 2 or 3 would indicate that segregation could be an issue and producers should modify the mix to provide more stability.

2.7.3. T₅₀. During placement, the flow rate of SCC is influenced by the viscosity. To find the relative measure of the unconfined flow rate, the T₅₀ test can be performed. A sample of concrete is placed in an inverted slump cone in one lift without any consolidation. The cone is raised as would be done for a slump flow test and the time is recorded in seconds that it takes for the outer edge of the concrete to reach a diameter of 20 in. A longer time would indicate that the mixture has a higher viscosity and a lower flow rate.

2.7.4. J-ring. To test the ability of the concrete to remain cohesive while flowing between obstacles, the passing ability of the concrete should be determined. The J-ring can provide this information as well as being easy to run either in a plant or in the field. Once again concrete is placed in an inverted slump flow cone in one lift with no consolidation. The cone should be placed concentric with a J-ring so that as the cone is

raised, the concrete must flow through the ring. Two diameters are measured perpendicular to each other and the average is recorded as the concrete's J-ring slump flow. The larger the slump flow, the farther the concrete can travel through reinforcement under its own weight.

2.7.5. L-box. In addition to the J-ring, the L-box test can also be used to determining the confined flow characteristics of the concrete. The apparatus is made of a horizontal and a vertical box in the shape of an L separated by a moveable gate. Concrete is placed in the vertical box and after the gate is raised, the concrete flows past vertical reinforcement and into the horizontal section. After flow has stopped, the height at the end of the horizontal section is expressed as a proportion of whatever remains in the vertical section. Should the concrete flow as easily as water, the ratio would be 1, since the two heights would be equal. The minimum ratio is considered to be 0., but as the ratio approaches 1 the flow potential increases.

2.7.6. Column segregation. In addition to flowing abilities, both confined and unconfined, segregation potential is also an important characteristic. To evaluate this property, a column segregation test can be performed. The procedure is relatively straightforward. A sample of fresh concrete is placed in a cylindrical mold in one lift without any consolidation. The column is allowed to rest in the cylinder for a prescribed period of time, and then the column is sectioned into three segments with the top and bottom sections each accounting for a quarter of the total column volume. The concrete that comes from the top and the bottom sections are washed over a No. 4 sieve and the masses from the top and bottom sections are determined. From this, the percent segregation is calculated. No percent segregation has been set as acceptable, but it is generally assumed that any value under 10% is tolerable.

2.8. SHEAR STRENGTH OF SCC

2.8.1. Hassan, Hossain, and Lachemi, 2010. An investigation was conducted within the Civil Engineering Department of Ryerson University in Toronto, Canada to study the shear strength, cracking behavior, and deflection characteristics of SCC and compare these results to NC. The test consisted of casting and testing 20 beams containing no shear reinforcement under a three point loading condition. The variables

that were modified were the concrete type (SCC or NC), coarse aggregate content, beam depth, and longitudinal steel reinforcement ratio. The performance was then evaluated based upon several different factors such as the crack pattern and width, load at either the first flexural or shear crack, ultimate shear resistance, post-cracking shear resistance and ductility, load-deflection response, and failure mode. The conclusion was drawn from the testing that in general, the shear strength of SCC is lower than that of NC. It was also concluded that the current code-based equations are still valid for predicting the crack width and first flexural cracking load and moment.

In general, the production of SCC involves increasing the fine aggregate content, incorporating mineral admixtures, and/or using viscosity modifying admixtures. This will result in a highly flowable mixture that will readily spread under its own weight with minimal segregation. This reduces or even eliminates the need for vibrators to achieve good compaction which will then in turn reduce the amount of labor during construction and the possibility of errors.

At the beginning stages of SCC production, there were two main concerns on the minds of engineers and designers regarding the concrete's shear strength. These were that the concrete's best defense against shear, the coarse aggregate, had had been reduced to promote flowability and passability, and the aggregate interlock mechanism was weakened due to the smoother fractured surfaces formed during loading.

The experimental program consisted of testing twenty beams having a 400mm width and shear span to total depth ratio (a/h) of 2.5. Ten of these beams were made using SCC, ten were made using NC, and none of the beams contained any shear reinforcement. Mix designs called for cement similar to an ASTM Type I and included ground granulated blast furnace slag to be used as supplementary cementitious materials for both types of concrete. Natural sand was used as a fine aggregate and a 10 mm maximum size crushed stone was used for the coarse aggregate. While the materials were the same between the two mix designs, the amounts were varied. The SCC mixture had 25% less aggregate by volume than the NC mixtures. The purpose of this change was to investigate how much of an effect aggregate interlock had on shear strength. To modify the flowability and the cohesiveness of the concretes, water reducers were used. A high-range water reducer (HRWR) similar to a Type F in ASTM C 494 was used for

the SCC mixture, and a water reducer (WR) similar to a Type A in ASTM C 494 was used for the NC mixture.

The beam testing setup consisted of a three point loading configuration with a hydraulic jack to gradually apply a concentrated load to the center of the beam. Four linear variable differential transducers (LVDTs) were used to measure the shear strain by attaching them diagonally to the front of the beam. Another LVDT was attached at the beam's midpoint to record the deflection at that point. Electrical strain gages were attached to the lower layer of steel reinforcement to measure the strain experienced by the bars at that point. The use of a computer-aided data acquisition system was used to record the load, displacements, and strains throughout the test. The beam was loaded in three stages: at 50%, 75%, and 100% of the expected failure load.

To compare the shear strength between the SCC and NC beams, the ultimate shear load first had to be normalized. This was accomplished by dividing the ultimate shear load by the square root of f'_c for each type of concrete. It was then discovered that the 25% lower coarse aggregate content found in the SCC beams was the main cause of lower ultimate shear loads in the beams. With less coarse aggregate, there was less aggregate interlock. It was pointed out that these tests were conducted using conventional strength concrete and results can only be applied to such at this point. Should a higher strength concrete be used, the aggregate itself would fail rather than the interface between the paste and the aggregate. This would mean that diagonal cracks would have a shorter path to travel and a lower resistance due to aggregate interlock.

To observe how the mechanism on aggregate interlock and dowel action play into the shear resistance of concrete from V_d (development of first diagonal crack shear) to V_u (ultimate shear), the ratio of V_u/V_d was calculated and studied for both types of beams. This ratio helps to analyze the post-cracking shear resistance of concrete beams due to aggregate interlock and dowel action. It was found that the ratios were lower for SCC than for NC. This supports the theory that with less coarse aggregate, the SCC is unable to develop the same amount of post-cracking shear resistance as NC.

The conclusions drawn from this set of experiments showed that there were similarities between the two types of concretes as far as crack widths, heights, and angles, as well as overall failure mode. This was as predicted by the reinforcement design and

the overall beam dimensions. It was found that the ultimate shear load increased as longitudinal reinforcement increased while the ultimate shear stress decreased as the overall beam depth was increased. One could conclude that the longitudinal steel keeps the cracks together thereby increasing the aggregate interlock and increasing the ultimate shear load. The shear stress reduction also can be explained. As the depth of the beam increased, there was a larger area for the shear to act on. If the same load is applied over a larger area one should expect the shear stress to decrease. The study also found that when comparing the shear strength of SCC beams to NC beams, the SCC beams were lower and this reduction was greater in deeper beams that contained lower longitudinal steel ratios. Once again the mix design for this test contained 25% less coarse aggregate by volume within the SCC. With less aggregate interlock, there was a reduction in shear strength. This reduction was increased even further by the reduction of longitudinal steel, which allowed the cracks to open wider, further reducing the shear strength of the concrete.

2.8.2. Kim, Hueste, Trejo, and Cline, 2010. In the paper entitled “Shear Characteristics and Design for High-Strength Self-Consolidating Concrete,” the effect of a lower aggregate content, which is typically found in SCC, was studied as it related to the shear strength of the material. Push-off tests were performed to determine the influence of aggregate and paste volumes on shear capacity. This information was then compared to NC samples.

It is known that shear strength of a reinforced concrete is dependent on the contribution of both the shear strength of the concrete itself as well as the shear reinforcement. If the strength of the concrete is reduced, the shear reinforcement will have to be increased to support the load. The goal of this research program was to determine if the current design equations were appropriate for estimating the shear strength of the concrete and finding the amount of reinforcement that would be required. Aggregate interlock is a significant contributor to concrete shear capacity. Therefore, when the amount of coarse aggregate is reduced, as it typically is for SCC mixtures, the shear strength is also reduced. When working with a high strength concrete, the strength of the paste matrix is increased making it closer to the strength of the aggregate itself, and as this happens more broken aggregate can be seen along the failure points. This means

that shear cracks in a high strength concrete will tend to travel through the aggregate rather than around it as it would if a lower strength concrete were used. This would mean that the distance that a crack would travel would be approximately the same regardless of the amount of aggregate. Tests were performed to see if the effect on shear is the same for high strength concrete as it is for lower strengths.

The variables that were tested were two 16-hour target strengths, two aggregate types (river gravel and limestone), and three coarse aggregate volumes. This combinations of these variables amounted to 12 SCC mixtures. The variables that were tested for NC were two 16-hour target release strengths and two coarse aggregate contents. This amounted to 4 NC mixtures to be used as control mixtures. A total of 48 push-off samples were fabricated and tested to determine shear characteristics as well as (4X8) cylinders for determining the compressive and splitting tensile strength of the concrete on the day of testing.

According to research performed by Mehta and Monterio (2010), the absorptive capacity of an aggregate can provide a rough estimate of the its strength. The more absorptive an aggregate is, the less strength it should have. The absorption of the aggregates that were used were both measured and it was found that the river gravel had an absorption of 0.78% and the limestone had a absorption of 1.43%. The Los Angeles abrasion test was also performed to see the relation between the resistance of the aggregate to impact and its correlation to strength. The test involves loading a specific gradation of the material being tested into a rotating drum with eleven steel spheres. After the specified number of revolutions, typically 500, the drum is stopped and the degraded sample is sieved and the percent lost is calculated. A material that has a higher resistance to abrasion, and in turn a higher strength, will have a lower percent loss. When the Los Angeles abrasion test was conducted on the river gravel and the limestone, the percentages lost were 16 and 29 respectively. This data would tend to indicate that because the limestone has a higher absorption and a higher percent loss it would be an inferior material for shear resistance.

After the properties of the concrete aggregate had been determined, the concrete could be batched and the fresh concrete properties could be determined. The tests that were performed on the concrete included the filling ability, slump flow, flow rate (T_{50}),

and VSI. These were all conducted in accordance with ASTM C 1611. The slump flow values that were measured stayed between 27.5 and 29.5 in. (699 and 749 mm). The air content was between 0.8 and 1.6% and the T_{50} ranged between 1.0 and 7.0 seconds. The VSI stayed between 0.5 and 1.0 indicating that this was a very stable mixture. This is important in almost every SCC application but it is especially important for shear testing because the aggregate needs to be as homogenous as possible. If the aggregates settled to the bottom, the shear values would be affected.

Push off tests were performed to find the shear strength of the concrete. This was then divided by the normal strength to provide a quantifiable comparative assessment of the amount of normalized energy due to the aggregate interlock. It was found that the volume effect of the coarse aggregate can be considered as a significant effect. The difference between the volume effect of river gravel and the volume effect of the limestone aggregate could not be clearly found.

The 28-day compressive strengths all exceeded 10 ksi, indicating that they were high strength concrete. The calculated values of the energy absorbed due to aggregate interlock and the shear stress/ normal stress ratio decreased as the crack width or slip increased. This shows that high strength concrete can exhibit aggregate interlock. Visually it was seen that lower concrete strength specimens tended to have less coarse aggregate fractures, this would lead to an increase in aggregate interlock. This could be seen visually and also in the larger amount of energy that was absorbed. While high strength concrete can still have some aggregate interlock, it is less than a lower strength concrete. As the strength of the paste increases closer to the strength of the aggregate, more aggregate is broken at failure, and if the aggregate fails, the result is less aggregate interlock.

Aggregate type also showed that it was a critical factor when it came to aggregate interlock. For all specimens, both SCC and NC, the river gravel showed more energy absorbed indicating more aggregate interlock than the limestone. The type of aggregate used is not the only factor that was important. The amount of the aggregate was also influential to the aggregate interlock. As expected, the energy absorbed was higher for concrete specimens that had a higher amount of coarse aggregate in them. This was true regardless of the type of aggregate that was used.

While the research has shown there is a lower contribution to shear strength due to aggregate interlock with SCC made with lower coarse aggregate contents, it is yet to be determined if this will require additional shear reinforcement. A study of typical girders is planned to see if additional shear reinforcement is required for precast and prestressed beams containing SCC. Also, the testing procedure did not test specimens made from SCC developed using chemical admixtures and higher coarse aggregate contents.

2.9. OPTIMIZATION OF SCC

The paper entitled “Optimization and Performance of Air-Entrained Self-Consolidating Concrete” (Khayat, 2000) studied the mechanical and physical properties of an optimized SCC mixture as well as characteristics of SCC that incorporated different types and contents of cementitious materials. It was recognized that to achieve proper bond to reinforcement, structural performance, and durability, it would be important that SCC have a high stability. This stability would provide some resistance to blocking when traveling through tight areas but also resistance to bleeding and segregation after casting. It is known that air entrainment of SCC can significantly reduce viscosity, which can lead to a decrease in cohesiveness and resistance to segregation. The objective of tests performed was to develop an air entrained concrete that still provided adequate resistance to segregation.

To prevent segregation within a SCC mixture, a designer has several basic options. The first is to increase the powder content, which will promote cohesiveness and stability while reducing the demand for HRWRA. These powders could be cement or supplementary cementitious materials and they work by increasing the packing density and reducing the interparticle friction. The second defense against segregation, should the designer choose not to modify materials or gradations, would be to add a VMA in addition to the HRWRA. Tests performed for this study included a combination of the two mentioned above and attempted to find the proper dosages for HRWRA, air entraining admixtures (AEA) and VMA, as well as testing different cementitious material contents and their effects on fresh properties.

The first phase of the optimization process set out to find acceptable dosages for HRWRA, VMA, and AEA. Variables that were studied in these nine batches were the flowability and the stability of the concrete. After dosages for the chemical admixtures were obtained, fourteen mixtures were prepared while varying the concentrations of cementitious materials and VMA. There were three different cementitious material contents tested and the water/cementitious material (w/cm) ratio ranged from 0.45 to 0.5. Following this step, five mixtures were selected from the previous 14 that showed an optimized balance of restricted deformability, resistance to surface settlement, HRWRA and VMA demands, and cost. These concrete mixtures were then tested for compressive strength, modulus of elasticity, drying shrinkage, rapid chloride-ion permeability, water permeability, air-void system, and freezing and thawing durability.

As a result of the first nine tests, it was found that mixtures made without any VMA and a moderate amount of cement experienced a relatively high settlement. Surface settlement can be related to the concrete's resistance to segregation. It was seen that with the addition of a VMA, there was an increased resistance to settlement for a given w/cm.

At the conclusion of testing, it was seen that it is possible to proportion an air-entrained SCC that will have high stability and resistance to blockage in congested areas. It was also shown that even mixtures that had high slump flow values still maintained a high resistance to surface settlements and a high stability. Regarding compressive strength, it was shown that concrete made with a 0.45 w/cm outperformed those made with a 0.5 w/cm. It was also seen that there was significant drying shrinkage even as a result of the higher water content. This could have been due to the smaller coarse aggregate content, leaving a larger paste volume which experiences shrinkage.

2.10. USE OF SUPPLEMENTARY CEMENTITIOUS MATERIALS IN SCC

Research performed by the Department of Civil Engineering at Gaziantep University set out to investigate how the use of binary, ternary, and quaternary cementitious blends of mineral admixtures could affect the properties of SCC. To find these relationships, 22 SCC mixtures were designed and cast to find an optimal mixture proportion. The control mixture contained only Portland cement while other mixtures

incorporated blends of Portland cement (PC), fly ash (FA), ground granulated blast furnace slag (GGBFS), and silica fume (SF).

Research performed prior to testing showed that incorporation of pulverized FA and limestone powder had lessened the amount of HRWRA required to achieve the desired slump. By incorporating these materials into the concrete mixture, the powder content was increased, improving the rheological properties of the concrete and improving the concrete's stability. One other benefit that was discovered was that because of the slower reaction of the supplementary cementitious materials, there was a reduced risk of concrete cracking due to heat of hydration, making the concrete more durable. Research has shown that blends of different cementitious materials such as these have shown beneficial results for concrete, so testing with a SCC was necessary while looking at characteristics such as self compactibility, targeted strength, and durability.

Testing showed that compressive strengths for concrete produced with a 60% replacement of PC with FA, the compressive strength was reduced approximately 40%. This could be corrected with the appropriate use of mineral admixtures. It was also seen that a SCC made with 10% FA and 10% GGBFS had the highest strength. This showed that the use of FA will generally lead to a reduction in strength, however, SCC made with GGBFS and/or SF will generally have strength comparable to concrete made with PC alone.

Shrinkage testing showed that within approximately the first 10 days of curing, all concretes performed approximately the same. At that point it can be clearly seen that concrete produced with FA or GGBFS had lower shrinkage values. It was also seen that as the amount of mineral admixtures continued to increase, the amount of shrinkage continued to decrease.

Conclusions drawn from testing showed that incorporating mineral admixtures into concrete will improve the filling and passing abilities of SCCs. This could be seen by the increased H_2/H_1 ratios for concrete made with these materials. Also as expected, the T_{50} slump flow times were decreased showing that the concretes had a higher filling ability and flowability. Overall there are real benefits to adding these cementitious

materials to SCC and generally as long as mixture proportioning is performed mindful of any negative effects that can be overcome.

2.11. TEMPERATURE INFLUENCES ON SCC

In the paper entitled “Influence of Temperature on Fresh Performance of Self-consolidating Concrete” researchers studied the effects of hot and cold weather on the properties of fresh and hardened concrete properties. The scope of the study attempted to test the unconfined workability, flow rate, passing ability, and dynamic stability of SCC throughout a range of temperatures that concrete is typically placed. On this project, three mix designs were tested, all having the same amounts of cement, fly ash, coarse and fine aggregates, and w/cm. The amounts of HRWRA and VMAs were modified to see their relative effects on workability at different temperatures. The three mix designs were then tested at 7 different temperatures ranging from -0.50 to 43.00°C (31.1 to 109.4°F), and the fresh and hardened concrete properties were determined for comparison.

It is known that cold temperatures will affect fresh and hardened performance of concrete by decreasing the workability, and retarding the setting and strength gain of concrete. If the effect of cold concrete is known more precisely it can be determined if it is necessary to heat the water or the aggregates to eliminate the adverse effects of cold materials. Cold temperatures are not the only problem; temperatures that are too warm can lead to accelerated setting and lower long term strength and hardened properties. Workability can be an issue if the temperature is high enough and the relative humidity is low, causing rapid evaporation of the free water. If concrete is placed in hot weather, the temperature can be cooled by simple methods such as adding ice to the mix water, shading the coarse aggregate, or adding more water to the mix design. If these methods are not enough, the use of plasticizers and super plasticizers can be better remediation materials in hot weather conditions on the job site instead of water.

It was seen that the performance of self-consolidating concrete was affected by both hot and cold temperatures. At hot temperatures, the concrete experienced a decrease in unconfined workability, increase in plastic viscosity, and improvement in stability. It was also seen that these performance issues could be overcome by over dosage of the admixtures to reverse the changes in the fresh properties.

Concrete that was poured in colder temperatures was not affected as much as concrete poured at higher temperatures. Concrete poured at -0.5°C (31.1°F) did not require and remediation by way of admixture addition. The gains in slump flow at lower temperatures were less than 1 in. (25 mm) and the flow rate and dynamic segregation resistance were unaffected.

Following testing the data was plotted and equations were developed to correlate the slump flow loss or gain due to hot and cold temperatures. These showed significant statistical relationships between the dependent and independent variables. These equations could be applied to determine the required optimum admixture dosages given the ambient temperature at placement.

2.12. SEGREGATION OF SCC

In the paper entitled “Effect of Mixture Design Parameters on Segregation of Self-Consolidating Concrete” (Hassan, 2006) researchers wanted to present a simple test method to assess the ability of SCC mixtures to resist segregation. The proposed test required the use of an apparatus consisting of a PVC tube 12 in. (305 mm) in height with a 6 in. (152 mm) diameter. The apparatus is broken down into four 4in. tall sections using leak-free joints that are hinged to a vertical steel rod for easy sliding. The penetration apparatus was modified slightly from four penetration heads instead of one and was mounted on a steel frame. Each head is approximately 25g (0.05 lb.) and 0.78 in. (20 mm) in diameter with a semi-spherical end. For the first segregation test, the four penetration heads are allowed to penetrate the concrete under their own weight just after the cylinder is filled and the depth is measured. After sitting for 30 minutes, the concrete in each part is washed over a 3/8 in. sieve. Anything trapped on the 3/8 in. sieve is retrieved and the mass is determined.

The experimental program consisted of 123 flowable concrete mixtures with an initial slump flow of 20 ± 0.4 to 30 ± 0.4 in. (500 ± 10 to 750 ± 10 mm). The screen stability test was performed as well as the proposed segregation method on the concrete. In addition to these, the slump-flow, T_{50} , L-Box test, V-funnel test, and compression strength test were performed to determine the properties of the concrete. Concrete

mixtures were prepared in accordance with ASTM C 192-00 “Standard Practice for Making and Curing Concrete test Specimens in the Laboratory.

This research showed that the ability of SCC to resist segregation decreases whenever the w/cm or the dosage of HRWRA is increased. This is especially evident whenever the w/cm was greater than 0.45. To combat the concrete’s inability to resist segregation, a VMA can be used and testing showed that as expected for a given w/cm and HRWRA dosage, as VMA dosage increases segregations decreases. It was seen that there was a point beyond which segregation was effectively controlled.

The coarse/total aggregate ratio showed a slight to negligible effect on the ability of SCC to resist segregation whereas the total content of cementitious materials had a mixed effect on segregation. It was seen that at a high w/cm increasing the cementitious materials caused an increase in segregation while at a lower w/cm increasing the content of cementitious materials slightly enhanced the concrete’s resistance to segregation.

3. SCC MIX DEVELOPMENT

3.1. INTRODUCTION

There are two different approaches to developing an SCC mix design. The first is a materials based approach which focuses on modifying the aggregate types and amounts. Typically the coarse aggregate content is reduced while the paste content is increased. To improve the flowability of the aggregate a rounder aggregate is typically desired. The rounder shape allows the aggregate pieces to roll past each other easier increasing slump. The disadvantages to this approach are that the rounder aggregate decreases the shear strength of the concrete. With a lower coarse aggregate content the aggregate pieces are farther apart reducing aggregate interlock, and as a result shear strength is reduced. The reduction in aggregate interlock can also be caused by the rounder aggregate; sharp edges on aggregates tend to hold together better than rounded edges.

To try and avoid the reduction in shear strength a second chemically-based approach was utilized for this project. The coarse aggregate and paste contents were kept the same as a NC. The ACI 211.1 document entitled “Standard Practice for Selecting Proportions for Normal, Heavyweight, and Mass Concrete” was used to develop a mix design. This mix design was then modified through the use of a HRWR and a VMA. This allowed for improved flowability without sacrificing on aggregate interlock.

3.2. BASE MIX DESIGN

Before testing could begin to test for concrete shrinkage or shear strength a self consolidating concrete mix design had to be developed. Concrete materials that were local and readily available were preferred and used for testing. During the mix development stage there were 15 batches created to determine the effects of different variables tested.

For a point of comparison a NC mixture was desired. To achieve this, the ACI 211.1 committee report was used, referred to as ACI committee report here. First a slump was assumed to be 6 in. (152 mm). This is larger than the recommended slump in Table 6.3.1, however, keeping in mind that the overall goal is to create a SCC mixture a higher slump was selected to further improve flowability. After a slump is known the

approximate water and air content requirements can be determined. A gradation of the coarse aggregate to be used showed that the nominal max size was 1in. (25.4 mm). Using this information combined with the desired slump, a water content of 340 pounds per cubic yard was determined. A w/c ratio was the next step in the process; 0.45 was selected since high strength concrete was not required and a high coarse aggregate content was being used. In addition, a more angular aggregate combined with a low w/c ratio could be enough to prevent the admixtures from producing SCC. Using the w/c ratio and the water content the amount of cement was determined. To maintain a high shear strength it was important that the coarse aggregate content be kept the same for all types of concrete being tested. The amount of coarse aggregate was determined by referring to Table 6.3.6 of the ACI committee report. Using the fineness modulus of the fine aggregate and the nominal maximum size of the coarse aggregate the coarse aggregate content was determined. The last step in the creation of the base mix design was to find the fine aggregate content. This was done by summing the volumes per cubic yard for the water, cement, and coarse aggregate and subtracting them from 1 cubic yard.

It was known that the efforts to preserve the shear strength of the concrete would compromise the flowabilty of the concrete mixture. This made it important that in any area possible changes be made to increase slump. One area that was selected was air content. By increasing the amount of air entrained within the concrete it was possible to obtain a slight increase in slump with minimal sacrifice to shear strength. Typically with a 1in. (25.4 mm) maximum aggregate size an air content of approximately 1.5 percent can be expected; this is usually from air trapped during the mixing process. An air content of approximately 6 percent was desired so an air entraining admixture became necessary. Micro Air, produced by the BASF chemical company was selected to achieve the desired air content. Trial batches were produced and tested to determine the dosage of the admixture that would produce a 6 percent air content. Another benefit achieved through the addition of a air-entraining admixture is that the air bubbles are more evenly spaced throughout the concrete and uniform in size. This adds to the concretes durability as well as the flowabilty in the fresh state.

3.3. ADDITION OF FLY ASH TO BASE MIX.

3.3.1. Fly ash effects. To begin mix design development it was important to observe what type and how much of an effect that a class C fly ash would have on the plastic and hardened properties of concrete. Fly ash was obtained from the Labadie Power Plant in Labadie, Missouri for testing. It is known that fly ash particles are shaped similar to microscopic spheres allowing them to act like small ball bearings when added to the concrete mixture. This will tend to increase the slump of the mixture with everything else the same. Since the overall objective is to create a self consolidating concrete, the use of fly ash can be helpful because it is less expensive than cement or high range water reducers but can still provide a moderate increase in the slump and workability of the concrete. There is a tradeoff that must be taken into account when working with fly ash; because fly ash is a pozzolan and it requires the Calcium Hydroxide from other cementitious materials for a reaction, the strength gain will take longer.

3.3.2. Test batches. The effect fly ash would have at different amounts of cement replacement was the first piece of information that was to be determined. A control mixture, referred to as the base in Table 3.1, was created and compared to concrete with different fly ash replacements. This control mixture had a w/c ratio of 0.45, a design slump of 6-in., and a nominal maximum coarse aggregate size of 1- in. An air entraining admixture was added to achieve an air content of 6 percent. Three other concrete batches were performed with the same mix designs except that cement was replaced with fly ash by 20, 30, and 40 percent respectively. The batch weights for these concrete mixtures can be seen in Table 3.1.

3.3.3. Test results. Following batching the slumps and air contents were taken on the concrete in the plastic state. The compressive strength was found at 7 and 28 days. It can be seen in Figure 3.1 that the fly ash increased the slump of the concrete dramatically from the control to 20%. It was also noted that increasing the fly ash replacement beyond 30% did not have a significant effect on the slump or the workability of the concrete; in fact the graph shows there was a decrease in slump. The compression test data was also plotted and is shown in Figure 3.2. It showed that at 7 days, as the amount of fly ash increased, compression strength decreased. When compression testing was performed at

28 days it was seen that as the amount of fly ash increased the compression strength also increased slightly. It was also noted that concrete with fly ash typically had a compression strength less than that of the control, which contained no fly ash. It was expected that the fly ash would react slower than a straight Portland cement concrete, however the tradeoff was that a higher initial slump could be obtained leading to a higher flowability of the SCC later. These results are explained in greater detail in the Materials and Test Results section.

Table 3.1. Fly Ash Replacement Trial Batches

1 kN = 224.8 lbs. 1m ³ = 1.31yd ³	Base (lb/yd ³)	20%(lb/yd ³)	30%(lb/yd ³)	40% (lb/yd ³)
Course Aggregate	1781.3	1781.3	1781.3	1781.3
Fine Aggregate	1004.2	982.3	971.3	960.4
Cement (Type 1)	755.6	604.4	528.9	453.3
Water	340.0	340.0	340.0	340.0
Fly Ash (Class C)	0.0	151.1	226.7	302.2
Micro Air (ml)	223.4	223.4	223.4	223.4

$$1\text{lb/yd}^3 = 0.593 \text{ kg/m}^3$$

3.4. SCC MIX DESIGN

3.4.1. HRWR effects. After testing the effect of a local class C fly ash on the plastic properties of concrete, testing began on concrete made using fly ash and the HRWR, Glenium 7500. This HRWR was selected for its ability to improve workability for application in SCC. Glenium 7700 was also considered, however, this product has a much faster setting time than the 7500. In a manufacturing situation such as a plant constructing prefabricated sections this would be ideal but was too fast for these tests. BASF, the manufacturer for Glenium 7500, recommends a dosage of 2-15 fl oz/cwt of cementitious materials. Typically a dosage between 5 and 8 fl oz/cwt is sufficient but can

be increased for use in SCC applications and depending on concrete materials, and jobsite conditions and applications.

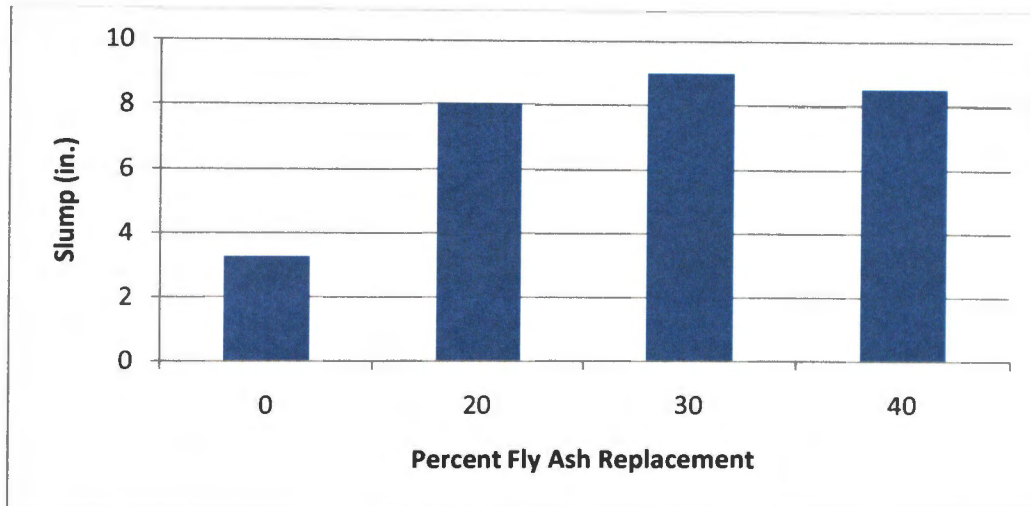

Figure 3.1. Slumps at Different Fly Ash Replacements

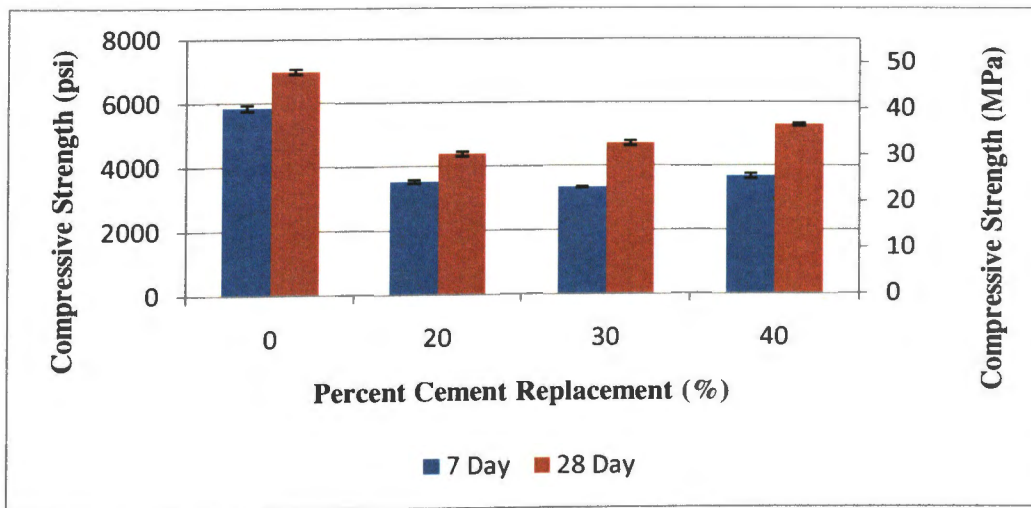

Figure 3.2. Concrete Compressive Strength With Fly Ash Replacement

3.4.2. Test batches. To see the effect of the Glenium 7500 three dosages were selected: 2, 6, and 9 fl oz/cwt. The concrete mix design was kept the same as previous testing with a cement replacement of 30%. The cement replacement was selected to balance the benefits of increased slump with the disadvantages of slower strength gain. After mixing, the following tests were performed on the fresh concrete: slump flow, J-ring, segregation column, unit weight, and air content. The information that was gleaned from these tests can be seen in the Table 3.2.

3.4.3. Test results. It was seen right away that concrete produced with a dosage of 2 fl oz/cwt, the lowest recommended by the manufacturer, would not be sufficient to produce a SCC, in fact a slump was taken instead of a slump flow. Even so, a slump of 6.75 in. (171 mm) was still high for a small dosage. The following tests showed much more promise; each one produced a slump flow of 25 in (635 mm). One could argue that a dosage of 6 fl oz/cwt would be the optimized dosage; it provided the maximum slump flow with the minimum amount of chemical admixture used. This was taken into account, but since a VMA was to be added later the higher dosage, 9 fl oz/cwt, was selected to proceed. The higher dosage of HRWR would hopefully offset any reduction in slump flow from the VMA.

Table 3.2. HRWR Trial Batches

Admixture	Dosage (fl oz/cwt)	Slump (in)	Slump Flow (in)	J-Ring Flow (in)	Static Segregation (%)	Air (%)	Unit Weight (lb/ft ³)
Glenium 7500	2.0	6.75		24.0	12.3	6.0	143.1
Glenium 7500	6.0		25.0	24.0	12.3	6.1	142.0
Glenium 7500	9.0		25.0	23.50	51.7	4.0	141.0

$$1 \text{ in.} = 25.4 \text{ mm}$$

$$1 \text{ yd}^3 = 27 \text{ ft}^3$$

$$1 \text{ lb/ft}^3 = 16.01 \text{ kg/m}^3$$

3.4.4. VMA effects. After testing with different amounts of Glenium 7500 it was seen that although filling ability was not an issue there was significant opportunity for segregation. In order to prevent segregation and still maintain the current gradation a liquid VMA was added. The VMA that was selected was Rheomac 362. According to the manufacturer's data sheet the admixture will not affect the compressive strength or setting time within the recommended dosage range, but by modifying the rheology of the concrete it can maintain a more homogenous concrete mixture.

3.4.5. Test batches. Two dosages of the Rheomac 362 were tested: 4 and 8 fl oz/cwt. These dosages represent a high and mid-range dosage of the VMA to study the effect on the fresh and hardened properties of the concrete. The same concrete mix design used to determine the HRWR dosage was used again this time with a HRWR dosage of 9 fl oz/cwt. The data that was collected can be seen in the Table 3.2.

3.4.6. Test results. It was seen that as the dosage of the VMA increased there was a decrease in the amount of segregation experienced by the concrete in the segregation column. This will keep the concrete more homogenous throughout placement and lead to better hardened properties. It was also seen in Table 3.3 that slump flow was not significantly changed, and J-ring flow even increased. This indicates that the passing and filling ability of the concrete was not significantly altered as a result of the addition of VMA. Knowing this, the high dosage of 8 fl oz/cwt was selected to provide the maximum amount of segregation resistance with minimum reduction in passing or filling ability. It should also be noted that the concrete made with this dosage of VMA had the highest visual stability index and was a favorite for those who worked with it in the lab.

3.4.7. Final Mix Design. After studying the data and observing the concrete in its plastic state the mix design that was selected for further testing contained 9 fl oz/cwt of HRWR and 8 fl oz/cwt of VMA. The coarse aggregate gradation was similar to that of a normal concrete mixture to maintain the shear strength of the concrete. Having a larger and more angular aggregate can improve the shear characteristics of a concrete but it will not improve the filling ability. This was the justification for using the highest dosage tested in the lab. Having a very high filling ability caused the concrete to have a very low viscosity and made it susceptible to segregation so the highest dosage of the VMA was also selected for further testing. The final mix design for SCC can be seen in Table 3.4

Table 3.3. VMA Trial Batches

Admixture	Dosage (fl oz/cwt)	Slump Flow (in)	J-Ring Flow (in)	Static Segregation (%)	Air (%)	Unit Weight (lb/ft ³)
Glenium 7500	9.0	24.5	19.5	22.4	5.8	141.0
Rheomac VMA 362	4.0					
Glenium 7500	9.0	24.3	23.0	3.5	6.2	142.1
Rheomac VMA 362	8.0					

1 in. = 25.4 mm

1 yd³ = 27 ft³1 lb./ft³ = 16.01 kg/m³

Table 3.4. Final Mix Design

Constituent	Batch Weight
CA (lb/yd ³)	1781.3
FA (lb/yd ³)	971.3
Cement (Type 1) (lb/yd ³)	528.9
Water (lb/yd ³)	340.0
Fly Ash (Class C) (lb/yd ³)	226.7
Chemical Admixtures	Dosages
Micro Air (ml)	223.4
Glenium 7500 (gal)	0.53
RheomacVMA 362 (gal)	0.47

1 lb./yd³ = 0.59 kg/m³

4. MATERIAL TESTING PROGRAM

4.1. INTRODUCTION

In order to compare the properties of NC and SCC, material test results were required. This section details the testing program that was conducted for both types of concrete. The tests that were performed on the fresh concrete include: density, air content, slump flow, J-ring, L-box, and segregation column. The tests that were performed on the hardened concrete include: compressive strength, modulus of rupture, shrinkage, and shear strength. In addition to these tests, the tensile strength and modulus of elasticity for the reinforcement steel was also determined. This chapter details the testing methods and results for the density, air content, slump flow, J-ring, L-box, segregation column, compressive strength, and modulus of rupture. Chapter 5 details shrinkage testing of the NC and SCC and includes comparisons with several prediction models. Chapter 6 details the shear testing and evaluation of both the NC and SCC.

4.1.1. Casting. All concrete was placed on the Missouri S&T property. The concrete required for the shear specimens is more than what could be reasonably produced on site so this was delivered by Rolla Ready Mix, located in Rolla, MO. Concrete was batched at the plant and liquid admixtures were added and mixed on site. Nine concrete cylinders were cast for each placement and stored near the shear specimens to have them experience the same temperature and atmospheric conditions. Concrete produced for compression testing, flexural strength, or any SCC fresh property testings, was typically produced in much smaller quantities in the Missouri S&T Concrete Lab, located in the Butler-Carlton Civil Engineering Hall.

4.1.2. Curing Conditions. After initial hardening, the shear specimens were moist cured for 7 days. A layer of wet burlap followed by a layer of plastic sheeting was placed over the beams to prevent drying and shrinkage cracking. For some concrete, it was observed that minor plastic shrinkage cracking occurred before water was applied to the surface. Specimens were moist cured in this condition for approximately 7 days after which they were removed from their forms to continue curing for a minimum of 28 days

before testing. Specimens were located in the High-Bay Laboratory of Butler-Carlton Civil Engineering Hall, a temperature controlled environment.

Concrete that was produced for the purpose of finding the compressive strength or modulus of rupture was placed in the Concrete Laboratory of Butler-Carlton Hall. Specimens were covered by a layer for plastic sheeting and stored in this temperature controlled environment for a minimum on 24 hours. They were then removed from their molds and placed in a moist-cure room until testing.

4.2. FRESH CONCRETE TESTING PROGRAM.

Table 4.1 summarizes the tests that were performed on the NC and SCC in their plastic state, the test methods followed, and the equipment used.

Table 4.1. Summary of Fresh Concrete Testing Program

Test	Test Method	Equipment Used
Density	ASTM C 138-10	Scale, Pressure Meter Bowl
Air Content	ASTM C 231-10	Type B Pressure Meter
Slump Flow	ASTM C1611/C1611M-09	ASTM C143 Slump Cone
J-ring	ASTM C1621/C1621M-09	ASTM C 143 Slump Cone, J-ring
L-box		Gilson L-box
Column Segregation	ASTM C1610/1610M-10	3-Part PVC Segregation Column

4.2.1. Density. The density of concrete was determined for SCC and NC throughout testing and performed in accordance with ASTM C 138-10b. Standard Test

Method for Density (Unit Weight), Yield, and Air Content (Gravimetric) of Concrete (ASTM C 138.2010). Concrete was placed in the base of the pressure meter pot used for determining the air content of the concrete. Concrete was placed in three lifts and was rodded 25 times each. The weight of the pot and concrete was taken and the concrete was removed. The empty pot was weighed and subtracted from the previous measurement to find the weight of the concrete alone. The weight of the concrete was divided by the known volume of the pot to determine the density of the concrete.

The density of the concrete typically measured approximately 146 lb/ft³ (2340 kg/m³). There were slight variations from batch to batch, but there was not a significant difference between the NC and SCC.

4.2.2. Air content. The air content of the concrete was determined for SCC and NC in accordance with ASTM C 231-10. Standard Test Method for Air Content of Freshly Mixed Concrete by the Pressure Method (ASTM C 231, 2010). A Type B pressure meter was used to find the air content of the concrete. Concrete was placed in three layers, similar to performing the density test, and rodded 25 times each. The concrete was struck off and the rim of the bowl was cleaned to ensure a good seal between the bowl and the lid of the meter. After the lid was clamped to the bowl, water was inserted into one petcock valve until it flowed out the petcock valve on the opposite side. The valves were both closed and air was pumped into the chamber until the appropriate initial pressure was obtained. The pressure was then released by opening the valve into the bowl and a reading was taken using the gage on the meter. To find the air content of the concrete, the aggregate correction factor was subtracted from the measurement taken off of the gage.

During mix design, it was determined that an air content of 6 percent was desired for both types of concrete. Test batches of concrete were produced and the dosage of the air-entraining admixture was adjusted to achieve the correct amount of air. By adding more air to the concrete, the slump was increased, thus increasing the concrete's workability and finishability.

4.2.3. Slump flow. Slump flow testing was performed on fresh self-consolidating concrete in accordance with ASTM C1611-1611M. Standard Test Method for Slump Flow of Self-Consolidating Concrete (ASTM C1611, 2009). The equipment that was

used for this test was a standard slump cone conforming to ASTM C143-10a. Standard Test Method for Slump of Hydraulic-Cement Concrete (ASTM C143, 2010) and a nonabsorbent, smooth, rigid base plate having a minimum diameter of 36 in. (915 mm). The slump flow was performed on a flat, level surface and filled using Filling Procedure B (Inverted Mold). The mold was filled in a continuous manner and the top surface was struck off. The mold was then raised in a steady upward lift with no lateral or torsional motion. After movement of the concrete stopped, two diameters were measured approximately perpendicular to each other and averaged for the slump flow. Figure 4.1 shows the mold being raised in a steady upward lift, and Figure 4.2 shows the diameter of the concrete being measured.



Figure 4.1. Raising the Mold During Slump Flow Test

The slump flow test is a measure of a concrete mixture's filling ability or the ability of the concrete to flow into and fill completely all spaces within the formwork under its own weight. The test was performed similarly to the conventional slump test but instead of measuring the slump distance vertically the spread of the concrete

horizontally was measured. The spread was measured twice and averaged to determine the slump flow.



Figure 4.2. Measure Concrete Diameter During Slump Flow Test

The degree of filling ability that is required of a concrete is dictated by the application; certain applications will require a high filling ability and slump flow while others will not. The first step to developing an SCC mixture is to establish the target value of slump flow. Generally the lowest slump flow required should be used to avoid the potential for instability and to optimize the performance of the concrete. Some factors that will influence the required filling ability of the concrete are the reinforcement level, the intricacy of the element shape, the wall thickness, the placement technique, and the element length.

To determine the slump flow required for testing, it was assumed there would be a high reinforcement level, low element shape intricacy, medium surface finish importance, high element length, and low placement energy. According to Table 2.5 – Slump Flow

Targets in ACI 237R-07, the target slump flow should be between 22 and 26 in. (559 and 660 mm).

To begin, testing was conducted using the same base concrete mix design and modifying the dosage of HRWR. This can be seen in Table 4.2. The HRWR that was used was Glenium 7500 and the dosages tested were 2, 6, and 9 fl oz/cwt. The manufacturer, BASF chemicals, recommends a dosage of 2 to 15 fl oz/cwt. To save on cost, the lowest dosage required to meet the required slump flow was desired, so an upper limit of 9 fl oz/cwt was checked as well as 6 fl oz/cwt.

As shown in Table 4.2, the lowest dosage of 2 fl oz/cwt did not produce a concrete that could be tested with a slump flow test. Instead, a traditional slump test was performed and the slump of the concrete recorded. At a dosage of 6 and 9 fl oz/cwt, a highly flowable concrete was produced with a slump flow of 25 in. (635 mm). To ensure that adequate slump flow was achieved and not lost with the addition of a VMA, the higher dosage, 9 fl oz/cwt, was selected for further testing. While it was the highest dosage tested for this research, it is still well within the manufacturer's suggested dosage and provides the required flowability.

Table 4.2. HRWR Dosages

Admixture	Dosage (fl oz/cwt)	Slump (in)	Slump Flow (in)
Glenium 7500	2	6.75	
Glenium 7500	6		25
Glenium 7500	9		25

1 in. = 25.4 mm

4.2.4. Passing ability. The passing ability of the self-consolidating concrete was found by performing the J-ring test in accordance with ASTM C 1621-09b. Standard Test Method for Passing Ability of Self-Consolidating Concrete by J-Ring (ASTM C 1621, 2009). The equipment that was used for this test was a standard slump cone conforming to ASTM C143-10a, a J-ring, and a rigid base plate. To perform this test, a sample of freshly mixed concrete was placed in a mold in the inverted position with a J-ring placed concentrically around it. The concrete was placed in one lift with no tamping or vibration and the mold was raised allowing it to spread through the J-Ring. After movement of the concrete stopped, two diameters were measured approximately perpendicular to each other and averaged. Figure 4.3 shows the J-ring after the movement of concrete has stopped.

The J-Ring test is a measure of a concrete's passing ability or the ease with which concrete can pass among various obstacles and narrow spacing of the formwork without blockage. Blockage occurs when there is segregation of the aggregate preventing flow around an area where there is an obstacle. Ideally, an SCC should have a high level of filling and passing ability to readily fill a section under the sole action of gravity. This is referred to as a high filling capacity.



Figure 4.3. J-Ring Test

The passing ability required of a concrete is also dictated by the application; certain applications will require a higher passing abilities than others. The variables that were considered when determining the required passing ability was the reinforcement level and the viscosity level. It was assumed that the reinforcement level was high and that the tight reinforcement could cause aggregate to segregate and potentially block flow. Narrowing of formwork was not an issue for this particular application, but because of the reinforcement level being high, a high passing ability was required.

To optimize the passing ability of the concrete, the HRWR dosage previously determined was used; this was 9 fl oz/cwt. The VMA that was selected for use in the SCC was Rheomac 362, manufactured by BASF chemical company. Two dosages were selected for the VMA, 4 and 8 fl oz/cwt. These represented the lower and higher dosages recommended by the manufacturer.

It was seen that as the dosage of VMA was increased, the J-Ring flow also increased, meaning the passing ability also increased. Table 4.3 shows that as the dosage was increased from 4 to 8 fl oz/cwt, the slump flow only decreased from 24.5 to 24.3 in (622 to 617 mm). This is a very small decrease in slump flow for a significant increase in passing ability of the concrete. The data indicated that the J-ring flow was the same for the high dosage of VMA as with the high dosage of the HRWR alone. The visual stability of the concrete was, however, much improved. The paste had a much thicker consistency while still maintaining a high filling ability. As this table shows, the slump flow was 25 in. (635 mm) before the addition of the VMA and 24.5 in. (622 mm) after the addition of the VMA. This seemed to show that the higher dosage of VMA would provide the best passing ability without making significant changes to the slump flow or filling ability of the concrete.

4.2.5. Static Segregation. The static segregation of a SCC can be determined by this test method by measuring the coarse aggregate content in the top and bottom portions of the cylindrical specimen. This can then be used to determine the potential a SCC has for segregation. It is important that a concrete be cohesive enough to prevent the aggregate from sinking to the bottom, this is especially important in deep sections such as walls or columns. As with other properties, the degree of segregation that is acceptable is dependent on the application.

Table 4.3. VMA Dosages

Admixture	Dosage (fl oz/cwt)	Slump Flow (in)	J-Ring (in)
Glenium 7500	9	24.5	19.5
Rheomac VMA 362	4		
Glenium 7500	9	24.3	23
Rheomac VMA 362	8		
Glenium 7500	9	25	23.5

1 in. = 25.4 mm

To perform this test, a sample of freshly mixed sample of SCC is placed in a cylindrical mold without tamping or vibration. The top surface of the concrete is struck off and the concrete is allowed to stand for 15 ± 1 minute. Immediately following the standing period, the concrete out of the top and bottom quarters of the column are removed and washed over a No. 4 sieve. The aggregate is then brought to a surface-dry condition by rolling in an absorbent cloth until all visible films are removed. The mass of the coarse aggregate from the top and bottom sections are then determined to the nearest 0.1 lb (0.045 kg). The percent static segregation can then be found using Equation 1. In this equation, CA_B is the mass of coarse aggregate in the bottom section of the column, CA_T is the mass of coarse aggregate in the top section of the column, and S is the static segregation in percent. If $CA_B \leq CA_T$ the percent segregation is zero.

$$S = \left[\frac{CA_B - CA_T}{CA_B + CA_T} \right] * 100, \text{ if } CA_B > CA_T \quad (1)$$

Table 4.4 shows data taken from the static segregation test. The first concrete mixture contained the HRWR Glenium 7500 only. This made the mixture highly flowable; however, there was significant segregation. The next test performed was for a concrete made using a HRWR and a low dosage of a VMA, Rheomac 362. It was found

that segregation improved; however, there was still a significant amount of segregation. Finally, a high dosage of VMA was added and it was seen that static segregation decreased significantly. This was the basis for the selection of a high dosage of VMA in the SCC mix design.

Table 4.4. Static Segregation Data

Test Number	Admixture	Dosage (fl oz/cwt)	Static Segregation (%)
1	Glenium 7500	9.0	25.4
2	Glenium 7500	9.0	22.4
	Rheomac VMA 362	4.0	
3	Glenium 7500	9.0	3.5
	Rheomac VMA 362	8.0	

4.3. HARDENED CONCRETE TESTING PROGRAM.

Table 4.5 summarizes the tests that were performed on the NC and SCC specimens, test methods followed, and specimen sizes.

4.3.1. Compression testing. Compression testing was performed in accordance with ASTM C39-10 (2010) Standard Test method for Compressive Strength of Cylindrical Concrete Specimens (ASTM C39, 2010). The specimens used for this were 4 in-diameter (100 mm) by 8 in long (200 mm) cylinders cast in the Concrete Laboratory of Butler-Carlton Hall (CLBCH). Testing was conducted in the Load Frame Room of Butler-Carlton Hall (LFBCH). The testing apparatus used was a 1200 kip (5,340 kN) Forney Compression Machine. The load was applied continuously and without shock to

the specimen at a rate of 35 ± 7 psi/s (0.25 ± 0.05 MPa/s). Based on the specimen size, this would correspond to a loading rate of 440 ± 188 lb/s (1.9 ± 0.8 kN/s).

Table 4.5. Summary of Hardened Concrete Testing Program

Test	Test Method	Specimen Geometry	Age At Testing
Compressive Strength	ASTM C39	4-in. (100 mm) dia. x 8-in. (200 mm) long cylinder	7 days, 28 days
Modulus of Rupture	ASTM C78	6-in. (150 mm) x 6-in. (150 mm) x 24-in. (600 mm)	28 days
Shrinkage	ASTM C157	4-in. (100 mm) dia. x 24-in. (600 mm) long cylinder	After Casting for 4 months
Shear Strength		12-in. (305 mm) x 18-in. (457 mm) x 168-in (4267 mm)	≥ 28 days

A total of 9 cylinders were cast for each trial batch of concrete. All specimens were cast in plastic cylinder molds with caps and moist cured for 7 days. The specimens were removed from the molds, marked, and returned to the moist cure chamber of CLBCH until their intended testing date.

Since the compressive strength exceeded initial expectations, a sulphur-based capping compound was used. The cylinders were capped in accordance with ASTM C617-10. Standard Practice for Capping Cylindrical Concrete Specimens (ASTM C617, 2010). The capping compound provided a flat surface that helped to eliminate high stress areas. The manufacturer states that the capping compound compressive strength exceeds 8,000 psi (55.2 MPa) at an age of 2 hours but may be used beyond 15,000 psi (103.4 MPa) with additional aging. All specimens were allowed to cure, at a minimum, four hours before testing. Sulfur capping was used in place of neoprene pads in steel end caps due to the stiffness required to test the higher compressive strengths. The testing apparatus for concrete compression testing can be seen in Figure 4.4.

4.3.1. Results. The results of compression testing performed on concrete containing different amounts of fly ash is shown in Figure 4.5. Each data point in the figure represents an average of three replicate specimens. Compressive strengths were closest for concrete batched with a 20 and 30 percent replacement of cement with fly ash.

It was also recognized that concrete containing fly ash had a longer continued hydration period and setting time than that of a 100 percent portland cement concrete. As a result, over a range of 7 to 56 days, there is a greater increase in compressive strength in the fly ash concrete over the 100 percent portland cement concrete. Conversely, there is a greater increase in the compressive strength of the 100 percent portland cement concrete over a period of 1 to 7 days, or during early age of the concrete. This can be seen more clearly in Figure 4.6, where the NC had a higher compressive strength initially until approximately 22 days, where the compressive strengths of the SCC and fly ash (FA) exceeded the NC.

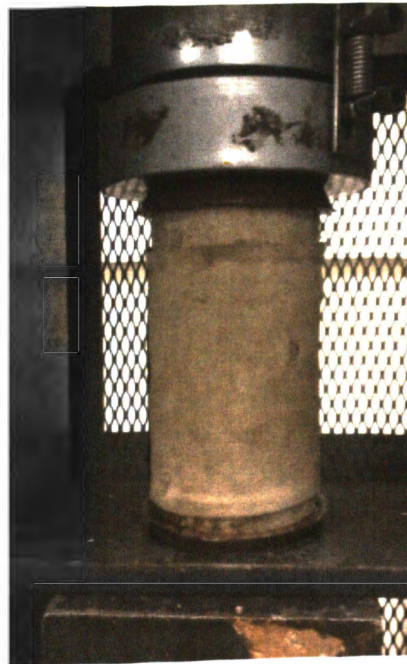

Figure 4.4. Concrete Compression Testing

All three concrete specimens had the same w/cm ; the SCC and FA had the same amount of cement and fly ash. This shows that there is a difference in compressive strength with the addition of fly ash; however, the difference in compressive strength as a result of the addition of the specific chemical admixtures used was negligible. This result is because the SCC and FA strength gain plots are nearly identical as time progressed.

4.3.2. Conclusions. As was expected, as the amount of fly ash increased, the compressive strength trend was to decrease up to an age of seven days. At 28 days, the control concrete, which contained no fly ash, still had the highest compressive strength, but it could be seen that as the amount of fly ash was increased, the compressive strength also experienced a small increase. This would seem to indicate that the fly ash reacted slower at first but over time would result in a comparable or higher compressive strength, which is consistent with previous research.

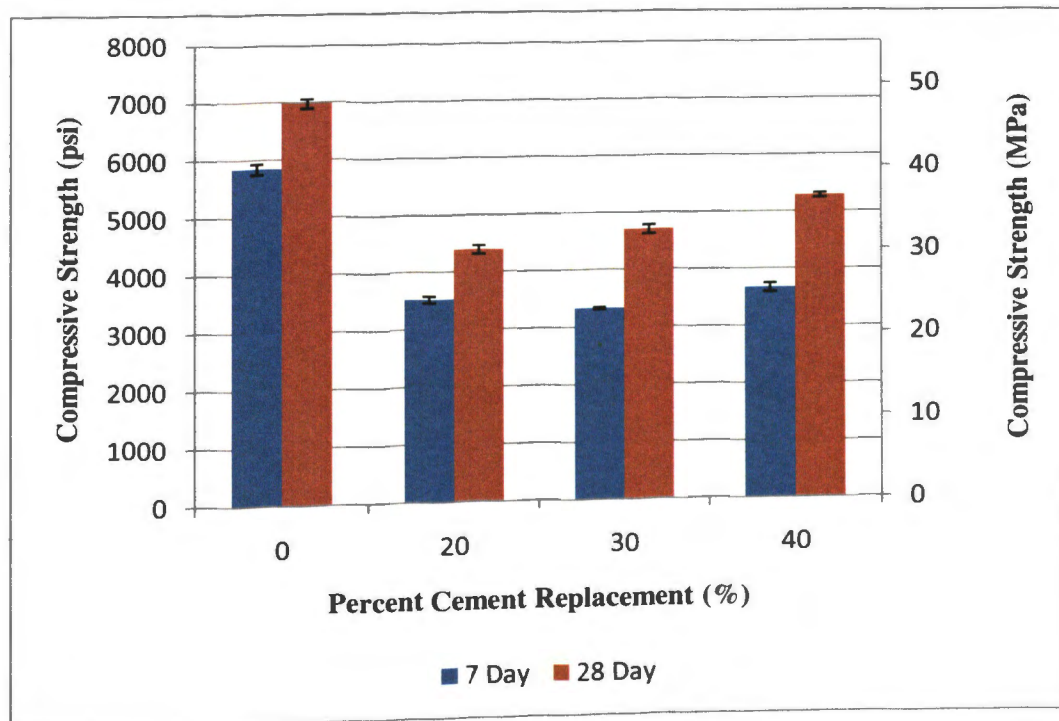

Figure 4.5. Concrete Compressive Strength With Fly Ash Replacement

After testing the effects of fly ash on the compressive strength of the concrete, a 30 percent replacement of cement with fly ash was selected as the optimum amount. As can be seen in the graph, the compressive strength was significantly lower at 30 percent than at 20 percent, but there was a significant increase in slump flow over the same range. There was a significant decrease in strength between a 30 to 40 percent increase in fly ash replacement as far as compressive strength, but there was not a large increase in slump flow. It was thus determined that the fly ash replacement selected provided the largest flowability without sacrificing the largest amount of compressive strength. Therefore, a 30 percent replacement of cement with fly ash was chosen for subsequent testing with HRWR and VMA admixtures to develop the SCC mix, as discussed in Sections 4.2.3 through 4.2.5.

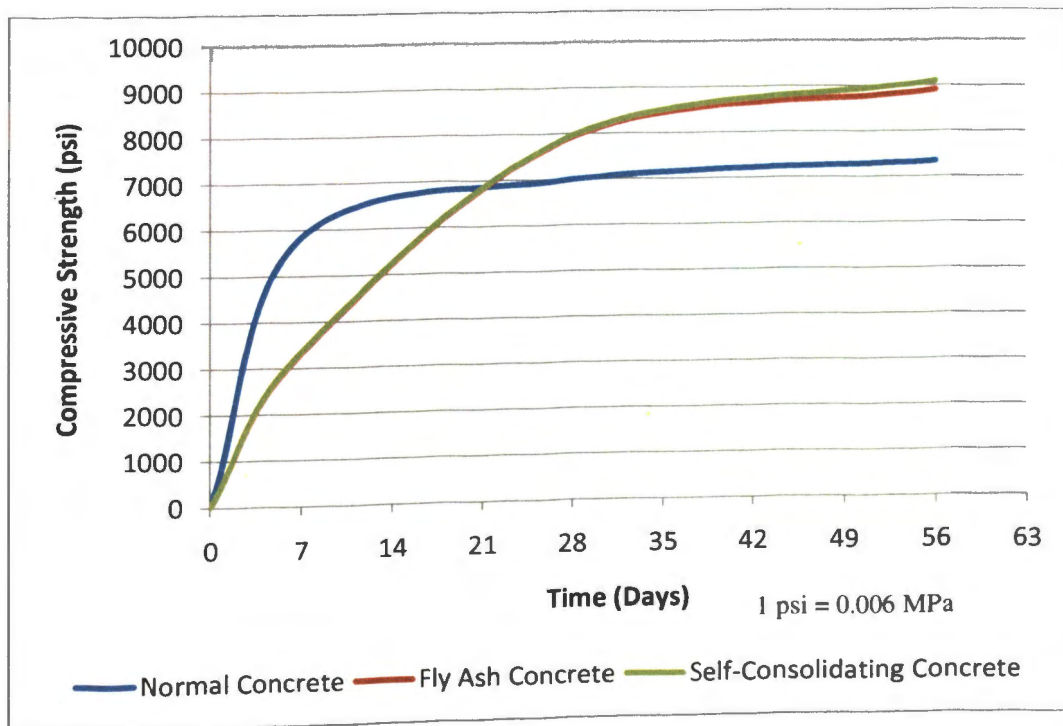

Figure 4.6. Compressive Strength vs. Time

4.3.3. Modulus of rupture. Modulus of rupture (MOR) testing was performed in accordance with ASTM C78-10, Standard Test Method for Flexural Strength of Concrete (Using Simple Beam with Third-Point Loading)” (ASTM C78, 2010). The specimens used for testing were beams measuring 6 in. by 6 in. by 24in. (150 mm by 150 mm by 600 mm) cast in the (CLBCH). The specimens were tested on the Tinius-Olsen testing machine in the (LFBCH). Specimens were loaded continuously and without shock to the breaking point. The load was applied at a rate that increases the maximum stress on the tension face between 125 and 175 psi/min (0.9 and 1.2 MPa/min). The testing apparatus is displayed in Figures 4.7 and 4.8. The specimen after failure is shown in Figures 4.9 and 4.10.

4.3.4. Results. MOR testing was completed as described in Section 4.3.3. Testing was performed on NC, FA, and SCC after final mix designs had been developed and tested for optimization of fresh concrete properties and compressive strength. Data collected from this test is shown in Table 4.6 and Figure 4.11. Each value reported is the average of three replicate specimens tested at an age of 28 days. The MOR values were normalized by dividing the square root of the compressive strength.

4.3.5. Conclusions. The data indicated that the MOR was greater for the FA and SCC specimens than for the NC even after normalizing for concrete strength. This also showed that SCC could be produced having material properties that meet or exceed those of traditional concrete mixtures if the aggregate types and amounts were maintained the same. Typically, MOR is affected by the angularity, type, and amount of aggregate that is used. Since the SCC produced for this research program used the same type and amount of aggregate for all mixes, the difference between the three was insignificant, as shown in Figure 4.11, particularly since MOR varies between $6\sqrt{f'_c}$ and $12\sqrt{f'_c}$ for normal concrete.

Table 4.6. Modulus of Rupture

Concrete Type	Modulus of Rupture (psi)	Normalized MOR	Standard Deviation
NC	634	8.8	0.1
FA	670	9.2	0.1
SCC	667	9.2	0.1

1 psi = 0.006 MPa



Figure 4.7. Modulus of Rupture



Figure 4.8. Modulus of Rupture

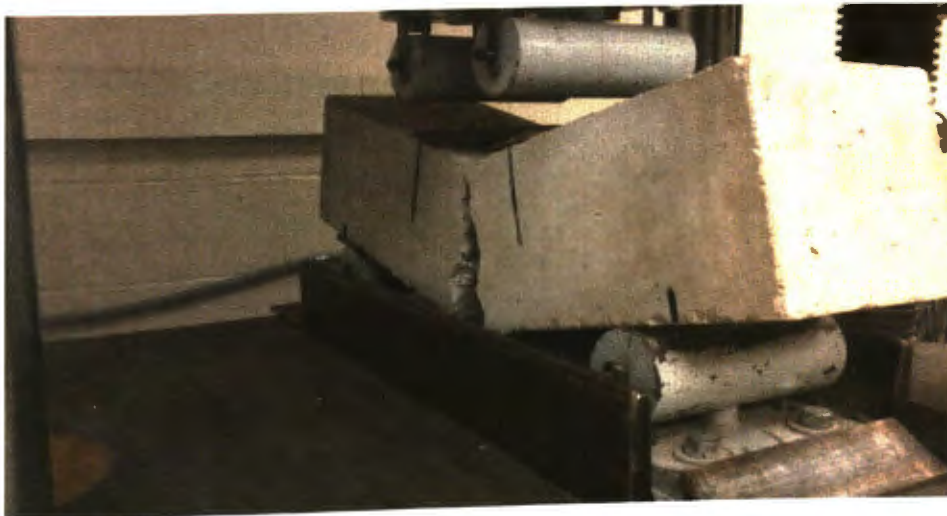

Figure 4.9. Modulus of Rupture After Testing

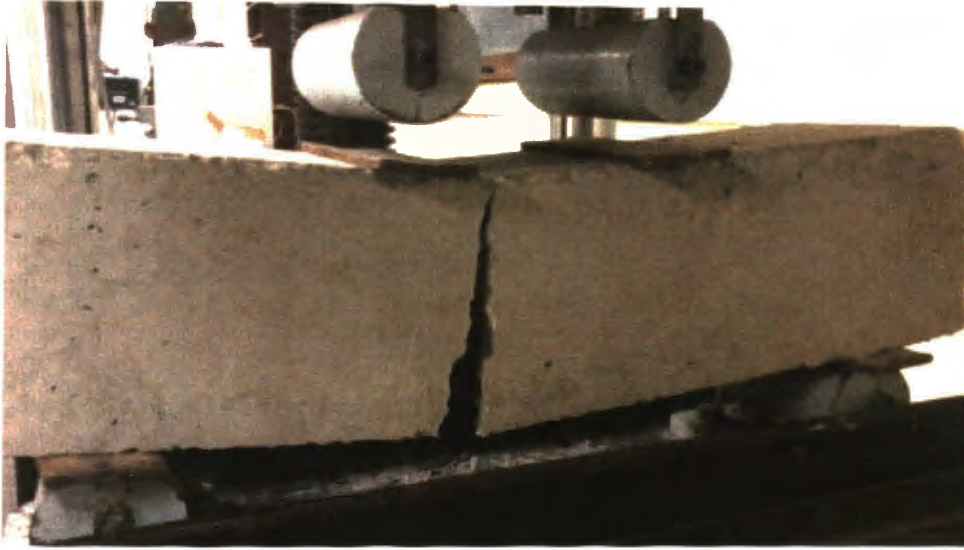

Figure 4.10. Modulus of Rupture After Testing

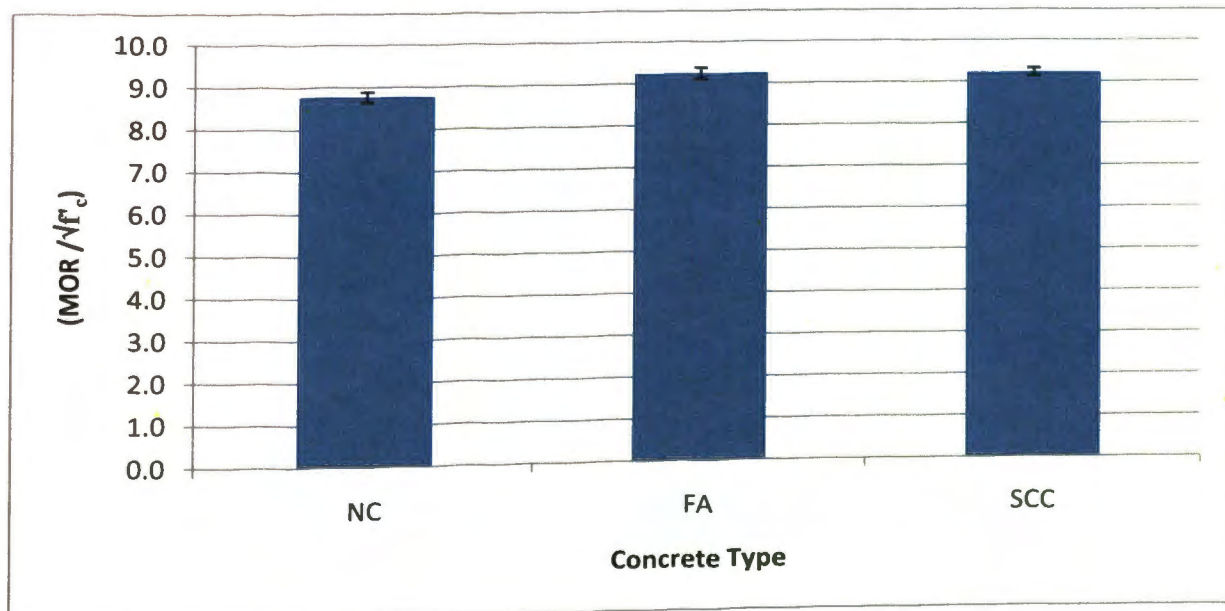

Figure 4.11. Modulus of Rupture

4.4. CONCLUSIONS

Materials testing was important for both the development of a SCC but also for the comparison of SCC to NC. It is important that the properties of SCC are known and that if there is a significant difference in properties of SCC compared to NC that these are taken into account in design. The tests performed in this section were selected to determine if the design parameters used for NC could also be applied to SCC.

To begin, concrete density and air content were taken for both NC and SCC. These are two tests that are routinely performed on fresh concrete samples. It was seen that there was not a significant difference between the SCC and the NC. This was as expected since the major constitutions of the concrete were not altered. The density of the concrete was found to be approximately 146 lb/ft³ (2340 kg/m³) for all concrete produced. The air content was also important when producing SCC because with the addition of air, concrete traditionally experiences an increase in slump and durability. The air content of several mix designs was taken and the dosage of an air entraining admixture was adjusted to achieve an air content of 6%. Air content testing was performed throughout materials testing to ensure that the air content remained relatively consistent throughout the testing process.

During the mix development phase for SCC, fresh concrete testing was performed to determine the optimum dosages of different admixtures. To determine the correct dosage of the HRWR the slump flow of the concrete was determined. It was seen that the slump flow, and the flowability of the concrete increased greatly as the dosage of the HRWR was increased from 2 to 6 fl oz/cwt. Beyond this point there was not a significant increase in the slump flow of the concrete even with additional HRWR. The highest dosage of the HRWR was still used to maintain a high slump flow after the addition of a VMA. After the dosage of HRWR was selected the dosage of VMA was determined. This was conducted much the same way as with the HRWR; different dosages were selected and slump flow tests were performed to determine the flowability of the concrete. It was seen that there was very little effect as a result of the addition of VMA on the slump flow of the concrete.

After the addition of VMA the passing ability of the concrete was tested. This was determined by performing the J-ring test. The diameter of the concrete taken from a J-ring test was compared to the diameter of the concrete taken from a slump flow test. A large difference will indicate that the concrete has very little passing ability and that is affected greatly by obstacles. It was seen that there was very little difference between SCC produced using a combination of a HRWR and VMA to that of an SCC using a HRWR alone. Visually the stability was improved greatly with the addition of a VMA and there was little impact on the passing ability of the concrete as shown by the J-ring test.

To show that the SCC had an improved stability as a result of the addition of the VMA the static segregation of the SCC was determined. This was determined by the static segregation test. This test was performed on concrete made using the HRWR alone, as well as a low and high dosage of VMA. It was seen that the static segregation was highest with concrete produced using the HRWR alone. This was as expected since there was little to prevent the aggregate from settling within the concrete mixture. The VMA works to effectively increase the specific gravity of the water in the concrete mixture and prevent segregation. The low dosage of 4 fl oz/cwt for the VMA showed little improvement over the HRWR alone, however, the high dosage of 8 fl oz/cwt showed significant improvement. It was shown that for the VMA to be effective the higher dosage of VMA would be required to prevent segregation.

After the mix design had been developed for the fresh properties of SCC the hardened properties were tested to determine if the concrete would still be acceptable. To begin the compressive strength was tested for concrete produced with different amounts of fly ash. The different cement replacement percentages that were tested were 0, 20, 30, and 40. It was seen that as the amount of fly ash was increased there was a decrease in early age strength. Concrete containing higher percentages of fly ash had longer hydration periods, but had higher compressive strengths after approximately 21 days. Knowing that the long term compressive strength would be greater and the slump flow would be increased as a result of the addition of fly ash the fly ash cement replacement percentage of 30% was selected. This afforded the benefits of increased slump flow in

the fresh state while still maintaining the higher early age strength of a portland cement concrete.

MOR is another common hardened concrete property that was determined after concrete mix design development and used to compare SCC to NC. The MOR was determined by testing a beam and normalized by dividing this value by the square root of the compressive strength of that particular concrete. This compressive strength was determined by testing a cylinder cast from the same batch of concrete. It was seen that there was not a significant difference between the MOR of SCC and FA concrete. SCC was also shown to be slightly higher than NC. Overall it was shown that there was little difference between concrete produced with or without a HRWR and VMA regarding MOR.

5. SHRINKAGE

5.1. METHODOLOGY

In order to find the shrinkage of the SCC and compare it to that of NC, a modified version of ASTM C 157-08, Standard Test Method for Length Change of Hardened Hydraulic-Cement Mortar and Concrete (ASTM C 157, 2008) was used. The only modification made to the specification was to use a specimen similar to those used by Myers (1998) in his research on high-performance concrete rather than the prism of 4 in (100 mm) square cross-section approximately 11-1/4 in. (286 mm) long. The specimens were placed in a PVC pipe with a diameter of 4 in (100 mm) and a length of 24 in. (600 mm). These modified dimensions allowed for 9 readings to be taken on each specimen, 3 along each of 3 longitudinal axes. There were four specimens cast for each mix design for a total of 36 readings at each time step. Figure 5.1 shows the specimens and the locations of the DEMEC points used to determine the strain in the concrete.

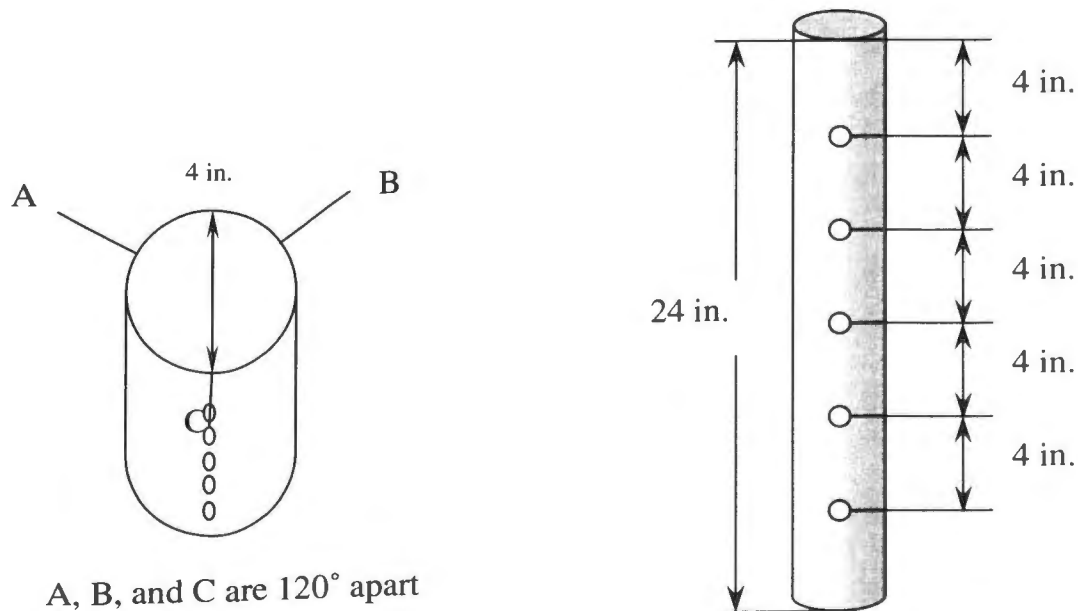

Figure 5.1. Shrinkage Specimens and DEMEC Locations

Within 24 hours of placement, the concrete was removed from the PVC mold using a dremel tool outfitted with a cutting blade. After the specimen was removed from the mold, marks were made to place the DEMEC points. The points were applied using a five-minute epoxy formulated for use on steel and concrete. A typical specimen is shown in Figure 5.2, and the group of specimens is shown in Figure 5.3. After the epoxy had time to harden, the initial DEMEC readings were taken. The average of all of the readings was then computed to serve as the total strain of the specimen. Data from subsequent days was used to extrapolate back to the initial casting to determine total shrinkage.



Figure 5.2. Typical Shrinkage Specimen

To create the plot of shrinkage vs. time, readings were taken every day for the first two weeks, every other day for the next week, once a week for the next three weeks, and once a month thereafter. The specimens were stored and measured in the concrete laboratory of Butler-Carlton Hall. The lab is temperature controlled and maintained an average relative humidity of $50 \pm 4\%$ and a temperature of $73 \pm 3^\circ\text{F}$. Generally, the temperature was relatively constant; however, there were days when the loading dock

doors were opened for extended periods of time allowing warmer, higher humidity air to enter and affect the results.



Figure 5.3. Concrete Shrinkage Specimens

5.2. RESULTS

Shrinkage is defined by ACI 209R-08, Guide for Modeling and Calculating Shrinkage and Creep in Hardened Concrete (ACI 209, 2008) as the decrease in volume of concrete over time. This shrinkage is due to drying shrinkage, autogenous shrinkage, and carbonation. Testing performed for the purposes of this research monitored drying shrinkage. Drying shrinkage is a decrease in the volume of concrete due to the loss of moisture within a concrete by evaporation. Tables 5.1, 5.2, and 5.3 show the amount of shrinkage experienced by the NC, FA, and SCC, respectively. In addition to the tables, Figure 5.4 illustrates the average shrinkage curve for the three concrete types.

Table 5.1. NC Shrinkage Strain.

Material	Specimen Number	Shrinkage Strian ($\mu\epsilon$)			
		7 days	20 days	40 days	254 days
NC	1	301	489	572	817
	2	295	480	566	822
	3	236	433	414	552
	4	198	395	462	701

Table 5.2. FA Shrinkage Strain.

Material	Specimen Number	Shrinkage Strian ($\mu\epsilon$)			
		7 days	20 days	40 days	254 days
FA	1	275	526	686	883
	2	253	672	741	960
	3	271	528	605	836
	4	158	413	493	712

Table 5.3. SCC Shrinkage Strain

Material	Specimen Number	Shrinkage Strian ($\mu\epsilon$)			
		7 days	20 days	40 days	254 days
SCC	1	145	420	488	714
	2	259	506	596	843
	3	278	538	635	861
	4	480	591	657	1005

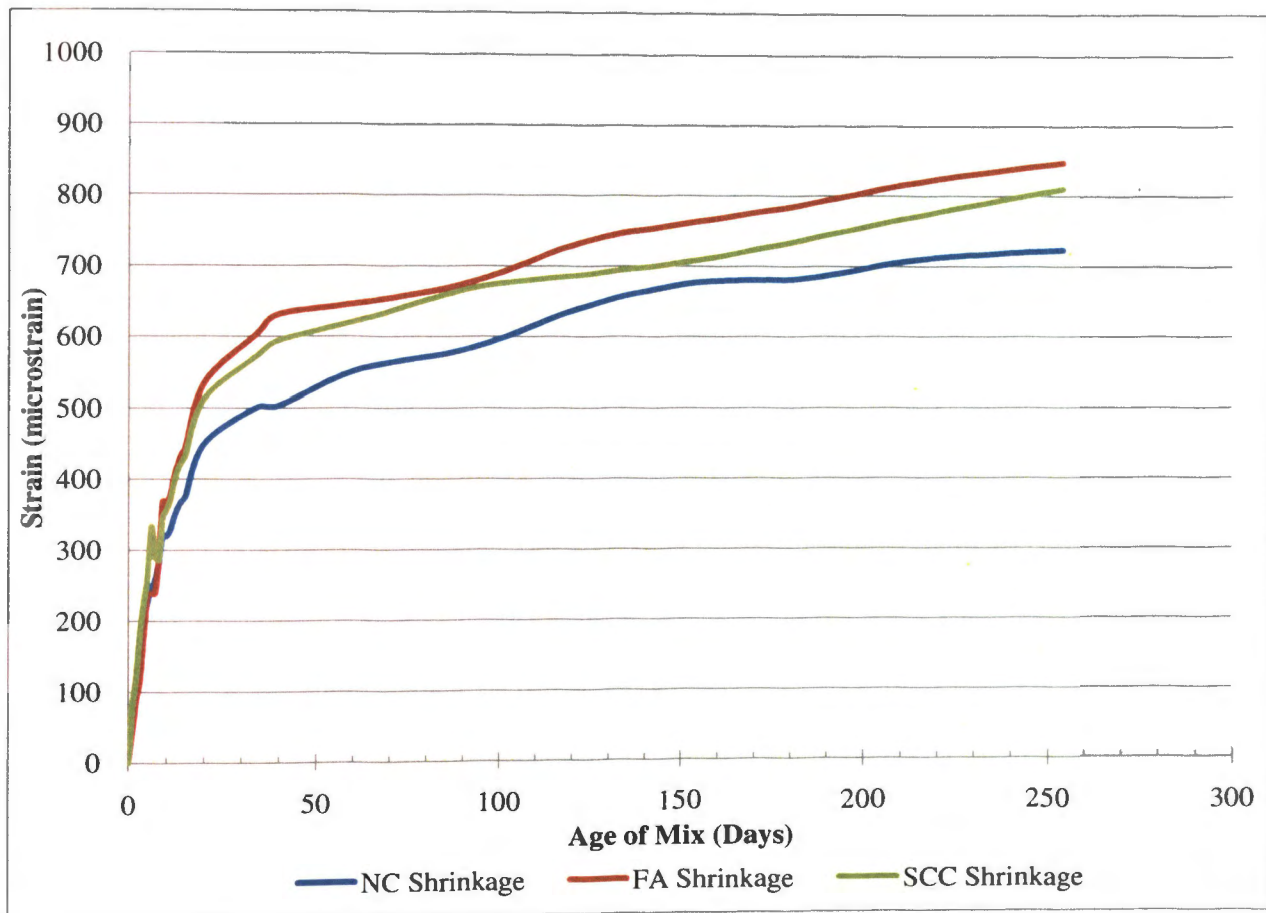

Figure 5.4. Shrinkage Plot

5.3. DATA ANALYSIS AND INTERPRETATION

The total amount of shrinkage was greatest for the FA concrete, followed closely by the SCC, and finally NC. As was expected, initial shrinkage was the greatest before it began to curve and eventually flatten out. Figure 5.5 shows the same plot as Figure 5.4 but includes error bars based on one standard deviation above and below the average strain for each point. This plot indicates that the shrinkage between the NC and the SCC is statistically insignificant since the error bars overlap. The plots for the FA and the SCC are even closer to each other and the NC is slightly lower. This seems to indicate that the addition of fly ash added slightly to the shrinkage of the specimens. This could be due to the fact that the fly ash has a longer hydration period and more water was allowed to

evaporate from the specimens. The data also indicated that the addition of HRWR and a VMA admixtures did not have a significant effect on shrinkage.

Typically shrinkage is affected greatly by the w/cm ; as more water is added to a concrete mix, more drying occurs. Other studies have shown that there can be less shrinkage with a limestone compared to a stiffer aggregate due to a chemical reaction between the paste and the limestone. This chemical reaction creates a stronger bond at the interface zone that resists shrinkage. The aggregate that was used in this research was a limestone found locally in Missouri. For the purposes of this research, the effects of fly ash, HRWR, and VMAs on shrinkage were desired so the w/cm , as well as the types and amounts of the aggregates, were kept the same for all concretes so these effects could be clearly seen.

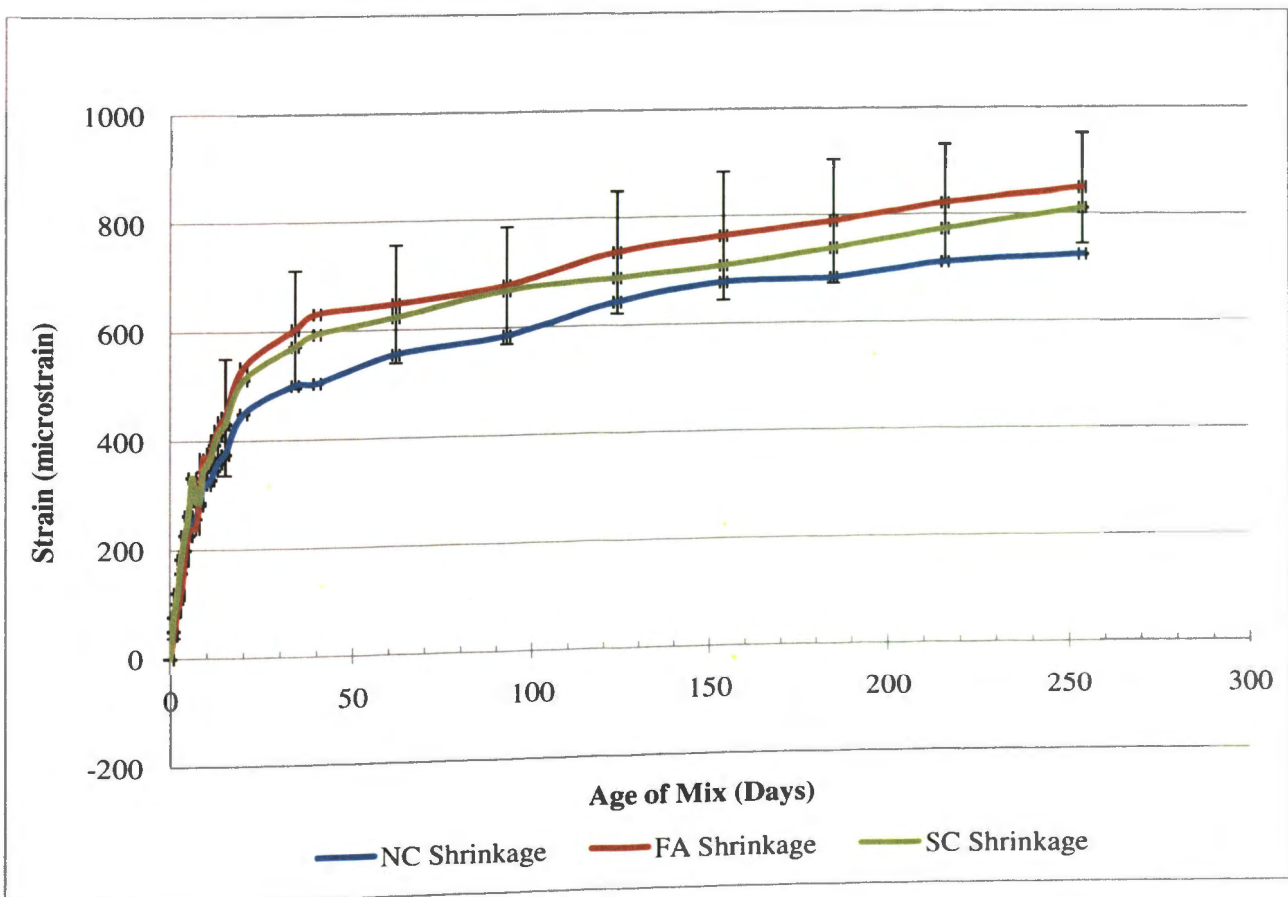

Figure 5.5. Shrinkage Plot With Standard Deviations

Tables 5.1, 5.2, and 5.3 are repeated as Tables 5.4, 5.5, and 5.6 but include predicted values based on relationships contained in ACI 209R. Models that were used to predict the shrinkage were the ACI 209R-92 model developed by Branson and Christianson in 1971, with minor modifications introduced in ACI 209R-82; the Bazant-Baweja B3 model developed by Bazant and Baweja in 1995; and the GL2000 model developed by Gardner and Lockman in 2001.

Table 5.4. NC Shrinkage Strain.

Material	Specimen Number	Shrinkage Strain ($\mu\epsilon$)			
		7 days	20 days	40 days	254 days
NC	1	301	489	572	817
	2	295	480	566	822
	3	236	433	414	552
	4	198	395	462	701
Average NC		258	449	504	723
ACI 209R		448	618	686	761
Bazant-Baweja B3		171	303	413	649
GL2000		155	256	334	504

Table 5.5. FA Shrinkage Strain.

Material	Specimen Number	Shrinkage Strain ($\mu\epsilon$)			
		7 days	20 days	40 days	254 days
FA	1	275	526	686	883
	2	253	672	741	960
	3	271	528	605	836
	4	158	413	493	712
Average FA		239	535	631	848
ACI 209R		448	618	686	761
Bazant-Baweja B3		171	303	413	649
GL2000		155	256	334	504

Table 5.6. SCC Shrinkage Strain

Material	Specimen Number	Shrinkage Strain ($\mu\epsilon$)			
		7 days	20 days	40 days	254 days
SCC	1	145	420	488	714
	2	259	506	596	843
	3	278	538	635	861
	4	480	591	657	1005
Average SCC		291	514	594	856
ACI 209R		448	618	686	761
Bazant-Baweja B3		171	303	413	649
GL2000		155	256	334	504

The ACI 209R (2008) empirical model developed by Branson and Christianson is presented in Equations 1 through 9. In the following equations, ϵ_{sh} is the ultimate shrinkage and γ_{sh} is the shrinkage correction factor. To calculate the correction factor, the following terms are used: $\gamma_{sh,tc}$ is the initial moist curing coefficient for curing times different from 7 days, $\gamma_{sh,RH}$ is the ambient relative humidity coefficient, $\gamma_{sh,vs}$ is a coefficient to account for the size of the member in terms of the volume-surface ratio other than 38 mm, $\gamma_{sh,s}$ is the slump factor, $\gamma_{sh,\psi}$ is the fine aggregate factor, $\gamma_{sh,c}$ is the cement content factor, and $\gamma_{sh,\alpha}$ is the air content factor.

$$\epsilon_{sh}(t - t_c) = \frac{(t-t_c)^\alpha}{f+(t-t_c)^\alpha} \cdot \epsilon_{shu} \quad (2)$$

$$\gamma_{sh} = \gamma_{sh,tc} \gamma_{sh,RH} \gamma_{sh,vs} \gamma_{sh,s} \gamma_{sh,\psi} \gamma_{sh,c} \gamma_{sh,\alpha} \quad (3)$$

$$\gamma_{sh,tc} = 1.202 - 0.2337 \log(t_c) \quad (4)$$

$$\gamma_{sh,RH} = 1.40 - 1.02h \text{ for } 0.40 \leq h \leq 0.80 \quad (5)$$

$$\gamma_{sh,vs} = 1.2e^{-0.00472v/s} \quad (6)$$

$$\gamma_{sh,s} = 0.89 + 0.041s \quad (7)$$

$$\gamma_{sh,\psi} = 0.30 + 0.041\psi \quad (8)$$

$$\gamma_{sh,c} = 0.75 + 0.00036c \quad (9)$$

$$\gamma_{sh,\alpha} = 0.95 + 0.008\alpha \geq 1 \quad (10)$$

The Bazant-Baweja B3 model solution developed by Bazant and Baweja is presented in Equations 10 through 16. Once again ε_{sh} in equation 10 is the ultimate shrinkage. To calculate the ultimate shrinkage, the following terms were calculated: $S(t - t_c)$ is the shrinkage time function, $\varepsilon_{sh\infty}$ is the ultimate shrinkage strain, $E_{cm607}/E_{cm(t_c+\tau_{sh})}$ is the time dependence factor, τ_{sh} is the shrinkage half time, $\varepsilon_{s\infty}$ is the nominal ultimate shrinkage, and k_h is the ambient relative humidity factor.

$$\varepsilon_{sh}(t, t_c) = -\varepsilon_{sh\infty} k_h \tanh \left[\frac{(t-t_c)}{\tau_{sh}} \right]^{0.5} \quad (11)$$

$$S(t - t_c) = \tanh \left[\frac{(t-t_c)}{\tau_{sh}} \right]^{0.5} \quad (12)$$

$$\varepsilon_{sh\infty} = \frac{-\varepsilon_{s\infty} E_{cm607}}{E_{cm(t_c+\tau_{sh})}} \quad (13)$$

$$\frac{E_{cm607}}{E_{cm(t_c+\tau_{sh})}} = 1.0805 / \left[\frac{(t_c+\tau_{sh})}{(4+0.85(\tau_{sh}+t_c))} \right]^{0.5} \quad (14)$$

$$\tau_{sh} = 190.8 t_c^{-0.08} f_{cm28}^{-0.25} \left[2k_s \left(\frac{v}{s} \right) \right]^2 \quad (15)$$

$$\varepsilon_{s\infty} = -\alpha_1\alpha_2[0.02565w^{2.1}f_{cm28}^{-0.28} + 270]x10^{-6} \quad (16)$$

$$k_h = 1 - h^3 \text{ if } h \leq 0.98 \quad (17)$$

The third model that the shrinkage data was compared to was the GL2000 developed by Gardner and Lockman in 2001. The solution to the model is presented in Equations 17 through 20. To calculate the shrinkage strains at time, t , in Equation 17, the following terms were calculated: $\beta(t - t_c)$ is the shrinkage time function, $\beta(h)$ is the ambient relative humidity factor, and ε_{shu} is the ultimate shrinkage strain.

$$\varepsilon_{sh}(t, t_c) = \varepsilon_{shu}\beta(h)\beta(t - t_c) \quad (18)$$

$$\beta(t - t_c) = [(t - t_c)/(t - t_c + 77(v/s)^2)]^{0.5} \quad (19)$$

$$\beta(h) = (1 - 1.18h^4) \quad (20)$$

$$\varepsilon_{shu} = 900k[4350/f_{cm28}]^{0.5}x10^{-6} \quad (21)$$

Figures 5.6, 5.7, and 5.8 show the plots of shrinkage for the three concrete types tested compared to the ACI 209R Model, the Bazant-Baweja B3 Model, and the GL2000 model, respectively. The plots show that the ACI 209R Model, Figure 5.6, is the closest at predicting the shrinkage of the three concrete types. It also tends to predict initial shrinkage slightly higher than the actual shrinkage measured but under predicts the shrinkage slightly at later ages. Both of the other empirical models, the Bazant-Baweja B3 Model in Figure 6.7 and the GL2000 Model in Figure 6.8, tend to predict shrinkage lower than the measured shrinkage, with the GL2000 Model significantly under predicting the shrinkage.

5.4. CONCLUSIONS

By looking at the values for shrinkage for NC and SCC it is possible to see how the two compare. The purpose of this testing was to determine what affect, if any, the chemical admixtures would have on shrinkage. In addition to these two types of concrete, an intermediate concrete made with a 30 percent replacement of fly ash and no chemical admixtures was tested. This helped to determine if any changes in shrinkage were a result of the addition of fly ash or if they were a result of the addition of a HRWR and VMA. Specimens were constructed and testing was performed using a modified version of ASTM C 157-08 used by Myers in his research in 1998.

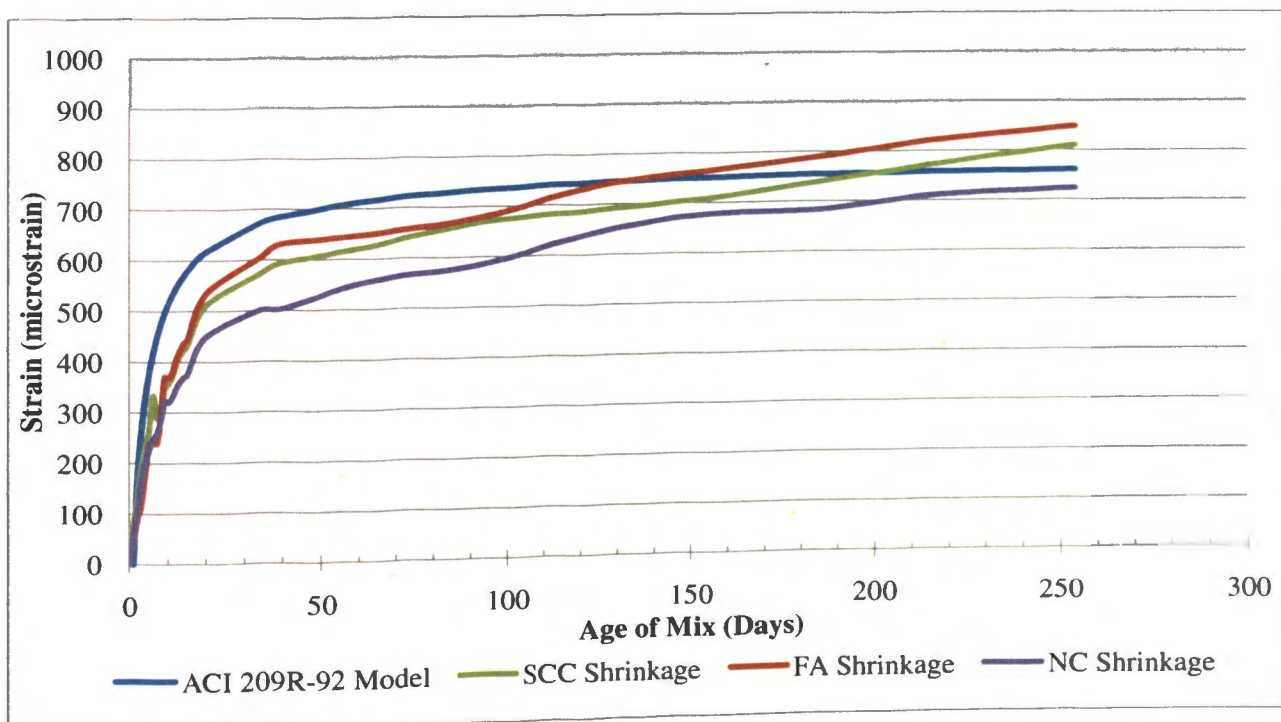

Figure 5.6. Concrete Shrinkage Compared to ACI 209R Model

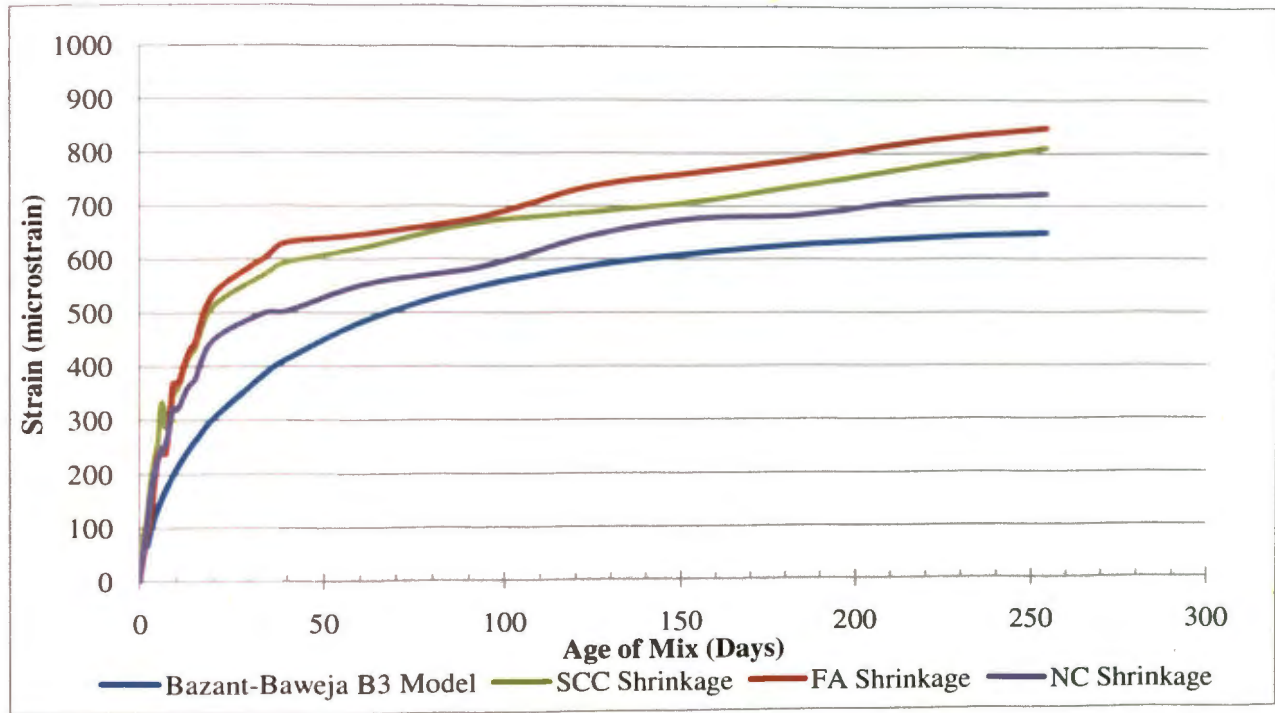

Figure 5.7. Concrete Shrinkage Compared to Bazant-Baweja B3 Model

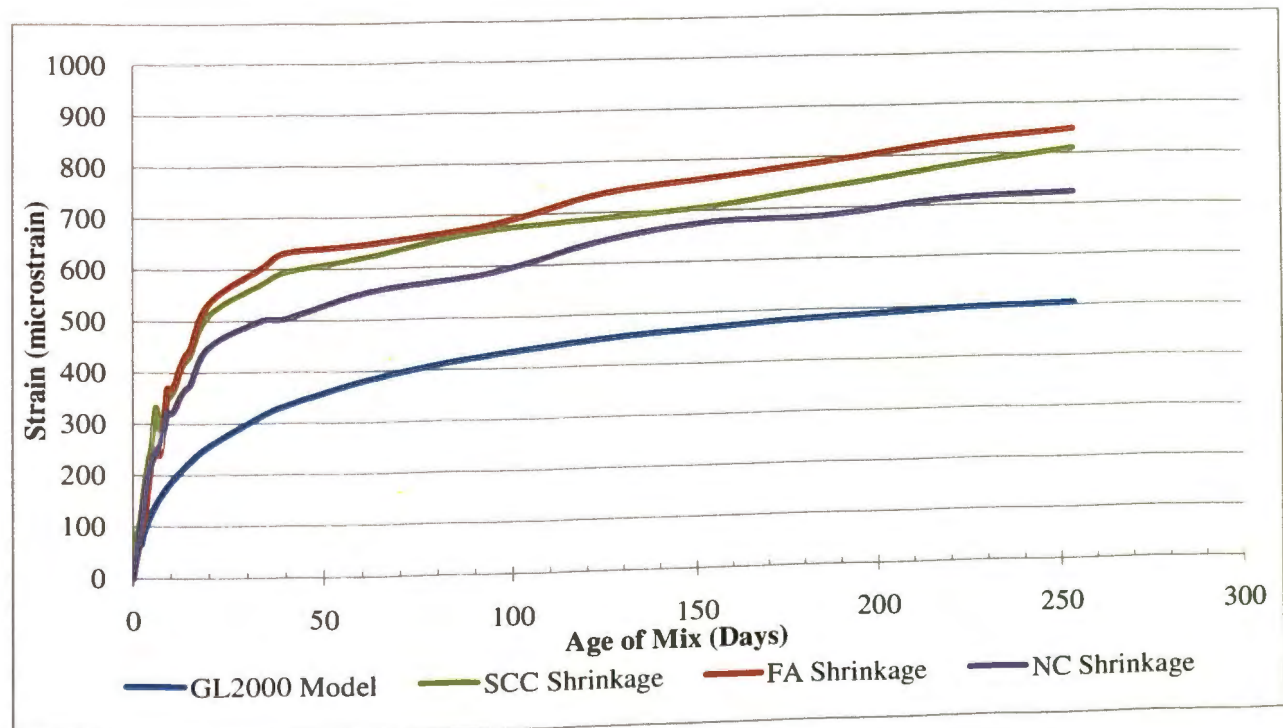

Figure 5.8. Concrete Shrinkage Compared to GL2000 Model

After shrinkage data was recorded and plots were made to show shrinkage strain over time the data was compared to predictions made by 3 shrinkage prediction models. These models were ACI 209R, Bazant-Baweja B3, and GL2000. These models were compared to the data collected to determine which most accurately matched the concrete developed in the lab.

By looking at plots showing shrinkage over time it was seen that the FA concrete had the most shrinkage and was followed closely by SCC. These two types of concrete matched the closest to each other and compared to them, NC had the smallest shrinkage. This would seem to indicate that the fly ash contributed to the slight increase in shrinkage observed. To determine if this increase in shrinkage was significant, standard deviation bars were added to select points. It was seen that many of the standard deviation bars overlapped indicating there was not a significant difference in the shrinkage between the three concrete types.

After comparing the different types of concrete to each other the shrinkage values determined in the lab were compared to values predicted by the shrinkage models. The trend predicted by all three models matched what was seen in testing; the initial shrinkage was the highest and as time progressed shrinkage slowed and began to plateau. It was seen that the ACI 209R model most accurately represented the shrinkage observed during testing. The initial predicted shrinkage was higher than what was seen in the field and the predicted shrinkage was lower than data taken in the lab. Both the Bazant-Baweja B3 and the GL2000 models under predicted the shrinkage for all three concrete types. Of the two, the Bazant-Baweja B3 was the closest to the plotted data, however, it was consistently lower throughout the time testing was conducted.

6. FULL-SCALE BEAM SHEAR TESTS

6.1. INTRODUCTION

Shear strength is a concern for designers when working with SCC. Typically, decreased shear strength with SCC can be attributed to higher paste content, rounder aggregate, and higher water to cement ratios (w/c) used to increase the flowability of the concrete. All of these cause a loss in aggregate interlock, which contributes significantly to the shear strength of the concrete.

Since the first SCC mixtures were developed, there have been many advances in chemical admixtures that allow SCC to be made without having to make all of these material changes. The goal of this research project was to take a slightly different approach to SCC mix design. Instead of making the material changes mentioned above and potentially decreasing the shear strength of the concrete, chemical admixtures would be used to achieve the fresh concrete properties required to have a SCC. This chemically-based approach would hopefully minimize any associated reduction in shear strength.

After the SCC mixture was developed, the material properties were compared to a more traditional or NC mixture. For each concrete type, SCC and NC, there were three shear reinforcement levels tested. The first set of beams had no shear reinforcement, the second set had the minimum amount required by ACI 318, and the last had an amount greater than the minimum required by ACI 318. This last series was referred to during testing as the maximum amount of shear reinforcing and was designed to ensure that the beam still failed in shear. Data from each set of SCC beams was compared to data from the corresponding NC tests as well as provisions from design codes commonly used in North America.

6.2. SPECIMEN DESIGN

When designing the beams for testing, three stirrup designs were selected: no stirrups, the minimum amount required by ACI 318 (2008), and some amount greater than the minimum amount. Design began by selecting the overall dimensions of the beam and then designing for shear and flexure. To ensure that the beam failed in shear,

the capacity of the beam in flexure had to surpass the calculated failure load in shear. For consistency, all beams used the same amount of flexural reinforcement, which was based on the capacity of the greatest amount of shear reinforcement.

Before calculations could begin, overall dimensions were selected. As this research project would use the same test setup as several other projects occurring in the lab at the same time, a slightly non-traditional four-point loading for shear testing served as the design setup. As noted previously, one aim of the research was to examine the affect of a chemically-based SCC on the shear capacity of “typical” beams. As a result, a shear span-to-depth ratio (a/d) between 2.5 and 6 was chosen for the testing (MacGregor, 2005). With the four-point loading setup, this resulted in a beam span length of 12 ft. (3660 mm), with an overall beam length of 14 ft. (4270 mm) to provide adequate end support and anchorage of the flexural reinforcement, as shown in Figure 6.1. It was also important that the beams could be easily produced using standard concrete forms and tested using the equipment in the Structural Engineering Research Laboratory of Butler-Carlton Hall (SERLBCH). After the span length was selected, it was important to ensure that the a/d was greater than 2.5. With this in mind combined with the desire to test realistic full-scale beam sizes, an overall beam depth of 18 in. (457 mm) was selected, which resulted in an a/d value of approximately 3.1. It has been shown that an increase in depth of a beam with little or no web reinforcement results in a decrease in shear at failure for a given compressive strength of concrete (f'_c), reinforcement ratio (ρ_w), and a/d (MacGregor, 2005). Beam depths also have an effect on the width and spacing of inclined cracks in the beams. As the depth increases, the crack spacings and widths tend to increase. Knowing that the width of the inclined cracks is based on the strain in the reinforcement crossing the crack, and the spacing of the cracks, the shear stress that can be transferred across the crack by aggregate interlock v_{ci} , will be less with a deeper beam. When v_{ci} is exceeded, the faces of the cracks slip, one relative to the other.

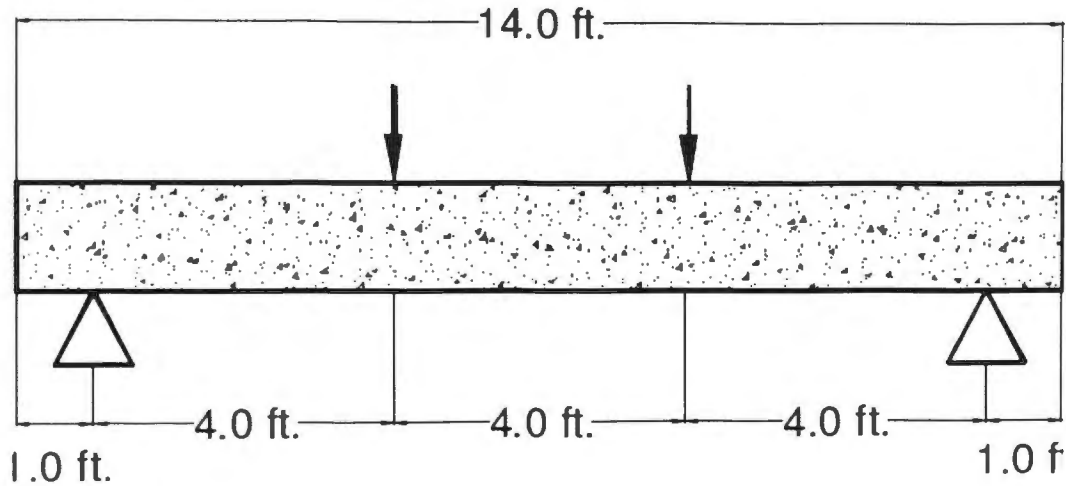

Figure 6.1. Loading Condition for Full-Scale Beam Shear Tests

After the overall dimensions of the beam had been chosen, design of the steel reinforcement could begin. To start, Equation 22 was used to determine the rectangular stress block depth, a . The equation assumes that the force in the tensile steel will be equal to the sum of the compressive concrete and steel forces. In this equation A_{st} is the area of steel in tension, f_y is the yield strength of the steel, f'_c is the compressive strength of the concrete, b is the width of the compression face, a is the depth of equivalent rectangular stress block, and A_{sc} is the area of the steel in compression.

$$A_{st}f_y = 0.85f'_c ab + A_{sc}f_y \quad (22)$$

The ACI 318-08 code allows for the use of an equivalent rectangular compressive stress distribution, or stress block, to replace the more exact concrete stress distribution which is non-linear. For concrete with $f'_c \leq 4,000$ psi, $\beta_1 = 0.85$. If the compressive

strength of the concrete is greater than this β_1 is reduced by 0.05 for each 1000 psi in excess of 4000.

$$a = \beta_1 c \quad (23)$$

By assuming an area of steel, and evaluating Equation 22, the depth of the equivalent rectangular stress block could be determined. The values for f_y and f'_c were both known from testing of tensile steel strength and previous concrete mix designs, and b was the width of the compression face, 12 in. (304 mm). This was already determined as an overall beam dimension.

Solving for the equivalent stress block depth allowed for the calculation of the moment capacity of the section. This calculation is shown in Equation 24. In this equation, M_n is the nominal moment capacity of the beam, f_{sc1} is the compressive strength required from the steel in compression solved for by iteration of Equation 22, d is the distance from the extreme compression fiber to the centroid of the longitudinal tension reinforcement, and d_t is the distance from the extreme compression fiber to the centroid of the longitudinal compression reinforcement.

$$M_n = A_{SC} f_{sc1} (d - d_t) + 0.85 f'_c b a (d - \frac{a}{2}) \quad (24)$$

Once the nominal moment capacity of the beam is known, the load that the beam should fail at can be predicted by setting it equal to the load applied by the actuator (P) multiplied by the distance from the support to the load. To ensure that the beam fails in shear, the load that the beam can support in a flexural capacity must be greater than the load that the beam can support in shear.

To find the load that the beam can support in shear, two terms must be calculated, the nominal shear strength provided by the concrete (V_c) and the nominal shear strength

provided by the shear reinforcement (V_s). The calculation for V_c is shown in Equation 25 and is taken from the ACI 318-08 code, equation (11-3). By rearranging equation (11-15) from the ACI code, the spacing can be determined; this result is shown in Equation 26. In this equation A_v is the area of steel required, f_{yt} is the tensile strength of the steel, and s is the spacing. $V_{s reqd}$ is the shear strength that must be supported by the steel. This is found in Equation 27.

$$V_c = 2\sqrt{f'_c}b_wd \quad (25)$$

$$S = \frac{A_v f_{yt} d}{V_{s reqd}} \quad (26)$$

$$V_{s reqd} = V - V_c \quad (27)$$

Equation 26 gives the suggested stirrup spacing according to ACI, or put another way, this is the minimum number of stirrups that will adequately support this beam. The minimum spacing of stirrups was calculated to be 7 in. and a spacing of 5 in. was selected to be the smallest spacing tested or maximum amount of shear reinforcing.

The location of steel reinforcement within the beam is shown in Figure 6.2. Five No. 4 bars served as compression reinforcement and 10 No. 8 bars served as tensile reinforcement. For calculations d was equal to 14.63 in. and d' was equal to 1.625 in. There was 1 in. of clear cover on the sides and 1.5 in. of clear cover on the top and bottom of the shear reinforcement. Table 6.1 shows the test matrix for beams tested in shear. Figures 6.3, 6.4, and 6.5 show the locations of the shear reinforcement for the beams constructed with no stirrups, 7 in. (178 mm) stirrup spacing, and 5 in. (127 mm) stirrup spacing, respectively. The construction of the reinforcement cages are described in more detail in Section 6.3. Tables 6.2 and 6.3 show the concrete mix designs used for the SCC and NC beams, respectively. See Chapter 3 for concrete mix development.

Table 6.1. Full Scale Shear Test Matrix

Specimen	Stirrup Spacing (in.)	Concrete Type	Reinforcement Figure Numbers
Control-NS-1	No Stirrups	NC	6.2, 6.3
Control-NS-2	No Stirrups	NC	6.2, 6.3,
Control-NS-3	No Stirrups	NC	6.2, 6.3
Control-7-1	7	NC	6.2, 6.4
Control-7-2	7	NC	6.2, 6.4
Control-7-3	7	NC	6.2, 6.4
Control-5-1	5	NC	6.2, 6.5
Control-5-2	5	NC	6.2, 6.5
Control-5-3	5	NC	6.2, 6.5
SCC-NS-1	No Stirrups	SCC	6.2, 6.3
SCC-NS-2	No Stirrups	SCC	6.2, 6.3
SCC-NS-3	No Stirrups	SCC	6.2, 6.3
SCC-7-1	7	SCC	6.2, 6.4
SCC-7-2	7	SCC	6.2, 6.4
SCC-7-3	7	SCC	6.2, 6.4
SCC-5-1	5	SCC	6.2, 6.5
SCC-5-2	5	SCC	6.2, 6.5
SCC-5-3	5	SCC	6.2, 6.5

1 in. = 25.4 mm

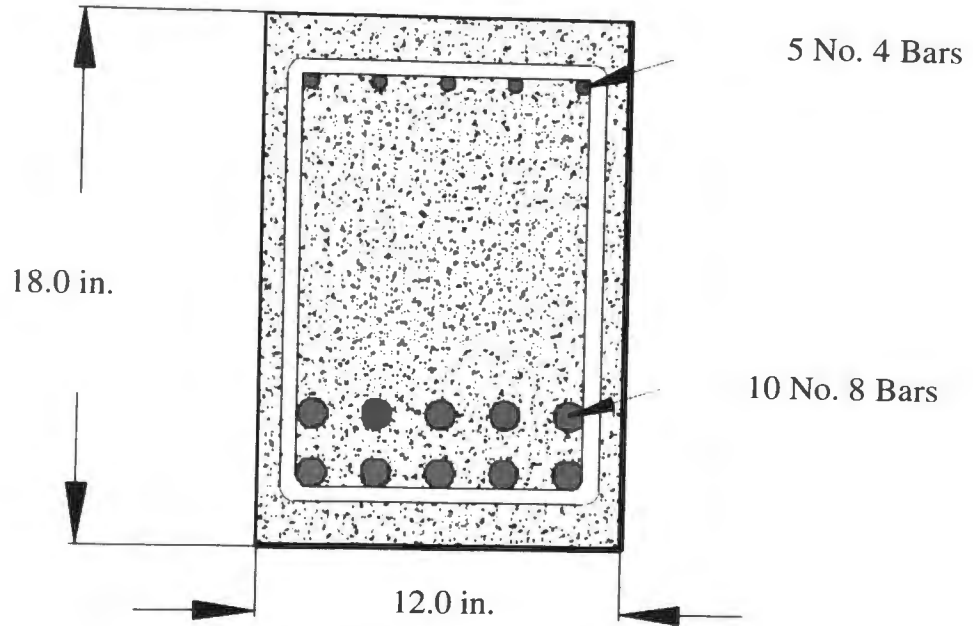

Figure 6.2. Steel Reinforcement Location

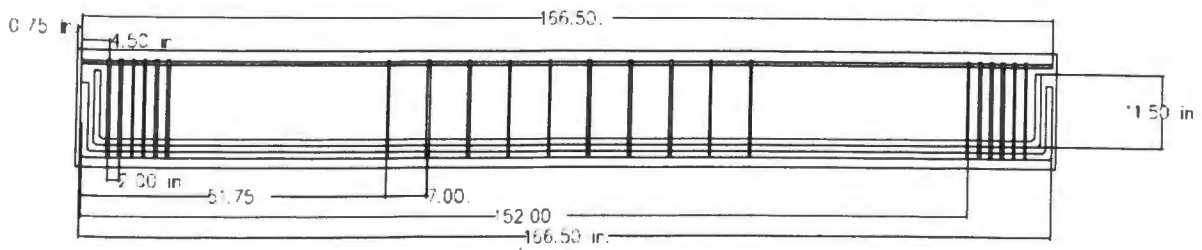

Figure 6.3. Shear Reinforcement With No Stirrups

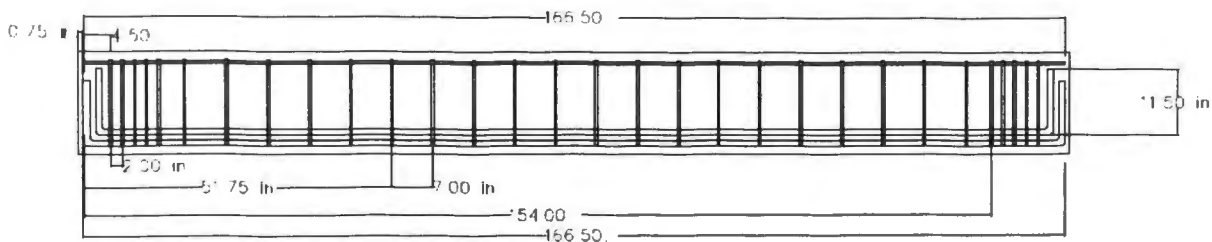

Figure 6.4. Shear Reinforcement With 7 in. Stirrup Spacing

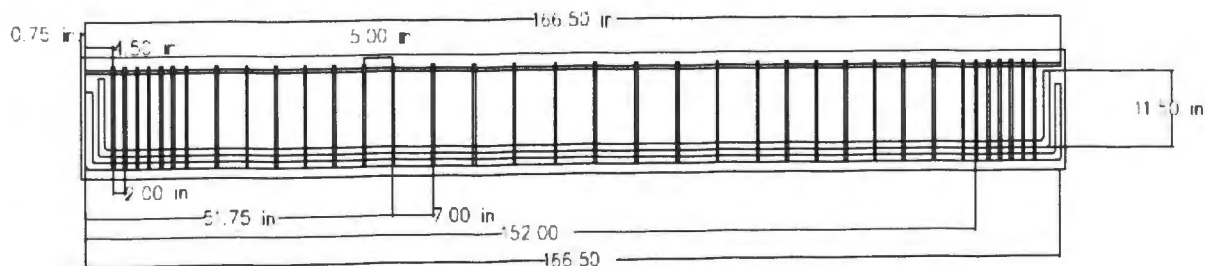

Figure 6.5. Shear Reinforcement With 5 in. Stirrup Spacing

Table 6.2. Final SCC Mix Design per Cubic Yard

Constituent	Batch Weight
CA (lb)	1781.3
FA (lb)	971.3
Cement (Type 1) (lb)	528.9
Water (lb)	340
Fly Ash (Class C) (lb)	226.7
Chemical Admixtures	Dosages
Micro Air (ml)	223.4
Glenium 7500 (gal)	0.53
RheomacVMA 362 (gal)	0.47

1lb. = 0.45kg

Shear strength testing was performed on the 14 ft (4270 mm) long beams in the SERLBCH. All specimens were allowed to cure for a minimum of 28 days before testing began. Three cylinders were kept next to the beams and were tested to determine the compressive strength of the beam on the day of testing.

Table 6.3. Final NC Mix Design per Cubic Yard

Constituent	Batch Weight
CA (lb)	1781.3
FA (lb)	971.3
Cement (Type 1) (lb)	755.6
Water (lb)	340
Chemical Admixtures	Dosages
Micro Air (ml)	223.4

1lb. = 0.45 kg

6.3. SPECIMEN CONSTRUCTION

This section will discuss the fabrication of the beams for shear testing as well as any construction related issues. The beam naming convention used throughout this section is as follows: “controls” are beams made with normal concrete and “SCC” are beams made with self-consolidating concrete. The following number is the spacing in inches between shear stirrups; where the symbol NS indicates there are no stirrups in the beam. The final number is the specimen number.

Formwork was acquired and assembled first in late May 2010. The sides were 18 in. (457 mm) tall and had a length of 14 ft. (4270 mm). The sides were attached to the form base by angle iron and form nails. The ends of the forms were constructed in the lab using plywood and wood framing and held onto the side pieces using bolts, washers and wing nuts. These were used for ease of assembly and disassembly. There was a total

of three beam molds such that a single series of beams would be constructed from the same batch of concrete.

Fabrication of the control specimen cages began early in June 2010. Reinforcing steel, consisting of No. 3, No. 4, and No. 8 bars, was delivered to the SERLBCH and cut to length using a rebar cutter. Ninety degree bends were then added to the ends of the No. 8 bars. The No. 8 bars were set on top of a set of work stands and 5 No. 8 bars, cut to lengths of 10 in. (254 mm), were used to maintain the correct spacing between the two layers of tensile reinforcement. After longitudinal reinforcement was in place, stirrups were added and tied to the longitudinal reinforcement using rebar ties. Three different stirrup designs were then used, no stirrups, a 7 in. (177 mm) spacing, and a 5 in. (127 mm) spacing. The latter two represented the minimum amount of stirrups required by ACI and the maximum amount used during testing, respectively, which could be compared to the concrete alone.

Up to this point, construction of the cages was done upside-down. When the reinforcement cage construction was complete, the cages were lifted off of the work stands using the overhead crane and rolled over. They were then placed back onto the work stands to facilitate application of strain gages, this can be seen in Figure 6.6. To begin, the area that was to receive a strain gages was ground smooth and sanded with 120 grit sandpaper. An acid cleaner was applied to a cotton cloth and used to clean the area followed by a base to prevent corrosion. Care was taken to not use the same cotton cloth twice, lest there be recontamination. The strain gages were then glued to the surface of the steel using the supplied adhesive and allowed to cure for approximately 5 minutes. After the glue had set, electrical tape was placed beneath the gage to prevent it from shorting out and giving an invalid reading. Wires were then attached to the leads of the strain gages. The wires were combined and routed out of the top of the cage. To prevent damage to the strain gage during concrete placement, tape was placed over the gage. The strain gages can be seen prior to concrete placement in Figure 6.7.



Figure 6.6. Reinforcement Cages



Figure 6.7. Strain Gages

The final step in the cage assembly was to add chairs to the bottom and sides. These held the cage in place, preventing it from leaning into the side or bottom of the form. This is important because adequate clear cover is necessary to ensure that the reinforcing steel has the proper development length and is being fully utilized. The forms prior to concrete placement can be seen in Figure 6.8.

After the cages were securely placed in the forms, concrete was ordered from Rolla Ready Mix. The mix designs used in Tables 6.2 and 6.3 were supplied to their office without any chemical admixtures. To compensate for variable moisture conditions of the aggregates and allow adjustments at the lab, the water content reported to Rolla Ready Mix was reduced by 10%. After the truck arrived, an initial slump was taken and water was added as necessary to achieve the design slump of 6 in. prior to the addition of admixtures. The slump test is shown in Figure 6.9. At this point, for the control specimens, NC was placed into the forms using a concrete bucket lifted using the overhead crane as shown in Figures 6.10 and 6.11. A vibrator assisted in ensuring that the concrete completely filled the formwork as shown in Figure 6.12. Finishing was done on all NC beams and can be seen in Figure 6.13. For the SCC beams, HRWR and VMA were added to the concrete and mixed at a high speed for 5 minutes after the slump of 6 in. (152 mm) was achieved. This can be seen in Figure 6.14. The SCC was placed using the concrete bucket but was not vibrated as shown in Figure 6.15. At this point, the concrete had a high flowability and a slump flow was taken, as shown in Figure 6.16. It was seen that minimal finishing was required for the SCC beams. For all concrete placements, 9 cylinders were produced for compression testing. Figure 6.17 shows the concrete placement process.

After the concrete was placed, it remained exposed to the air for approximately 3 to 4 hours. At this point, wet burlap was placed over the beams and plastic was placed over the top as a form of passive curing. It was observed that the SCC beams were more prone to small plastic shrinkage cracking; if this was the case, water was poured over the surface to increase the humidity beneath the plastic. Concrete placements happened concurrently with cage construction and began on June 28, 2010 and continued through August 10, 2010. After approximately one week, the beams were removed from the forms, labeled, stacked, and stored in the SERLBCH.



Figure 6.8. Forms Prior to Concrete Placement



Figure 6.9. Initial Slump Taken



Figure 6.10. Filling Concrete Bucket



Figure 6.11. Placing Concrete



Figure 6.12. Vibrating Concrete



Figure 6.13. Finishing NC



Figure 6.14. Addition of Chemical Admixtures



Figure 6.15. Placing SCC



Figure 6.16. Slump Flow



Figure 6.17. Concrete Placement Operations

The beams were transported within the lab using the overhead crane attached to hooks set into the concrete during placement. The beams were then allowed to cure for at least 28 days before they were tested. All cylinders that were cast during the pour were kept near their beam counterparts and tested at 28 days and on the day of testing.

6.4. SPECIMEN INSTRUMENTATION AND TEST SETUP

6.4.1. Specimen instrumentation. During construction of the reinforcement cages, strain gages were applied in the locations shown in Figures 6.18, 6.19, and 6.20 to monitor the strains in the reinforcing steel during testing. The strain gages were used to ensure that the beams failed in shear. If the beam fails in shear, the stirrups would yield before the longitudinal reinforcement yielded. If the longitudinal reinforcement yielded, the beam failed in flexure or in a combination of shear and flexure.

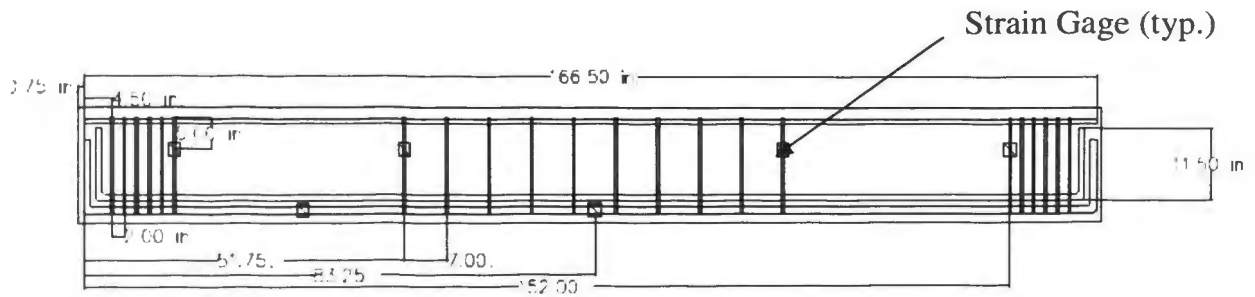

Figure 6.18. Strain Gage Location – Beam With No Stirrups

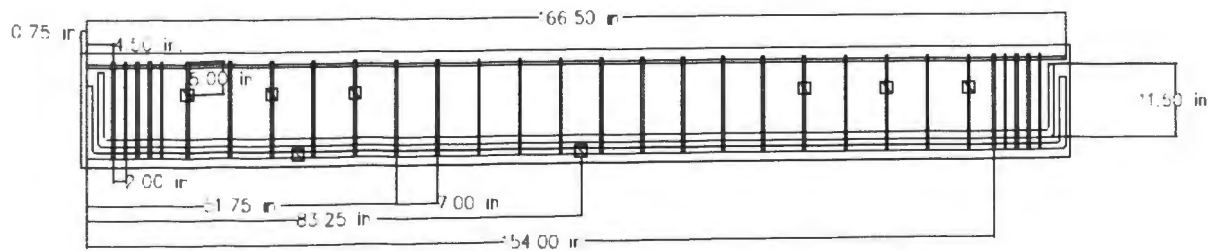

Figure 6.19. Strain Gage Locations – Beam With 7 in. Stirrup Spacing

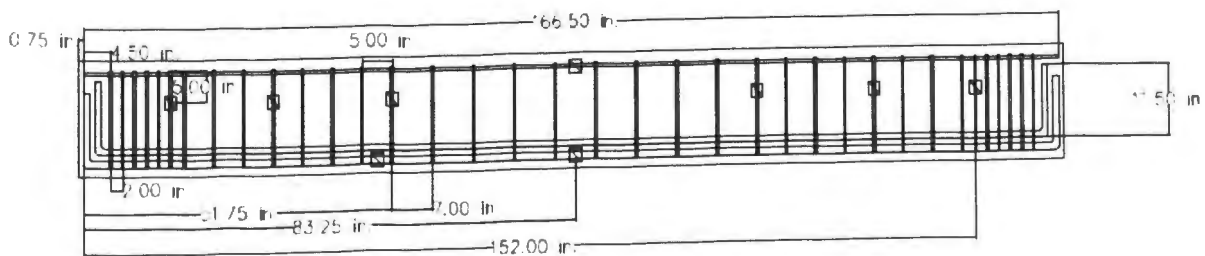

Figure 6.20. Strain Gage Locations – Beam With 5 in. Stirrup Spacing

To monitor the deflection of the beam, a bracket was attached to the side of the beam at the midpoint of the span. A stand was constructed to hold an LVDT vertically and measure the deflection of the beam at the midpoint. The setup is shown in Figure 6.21. The LVDT was attached to a data acquisition system (DAS) which recorded the deflection as the test progressed. The DAS is shown in Figure 6.22. The test was performed in a displacement-controlled method at increments of 0.05 in. (1.3 mm) based on preliminary calculations. After the deflection was achieved for each load step, the actuators were stopped and the deflection was held constant until an operator signaled the program to proceed to the next deflection interval. Also connected to the DAS were load cells located within the actuators. As testing progressed, the load cells relayed the load applied by the actuator to the DAS where the information was recorded. The test was assumed to be complete when the beam continued to deflect but no additional load was applied by the actuators. Typically, when this occurred, the actuators were run through two more deflection intervals to ensure that additional load would not be supported by the beam.



Figure 6.21. LVDT

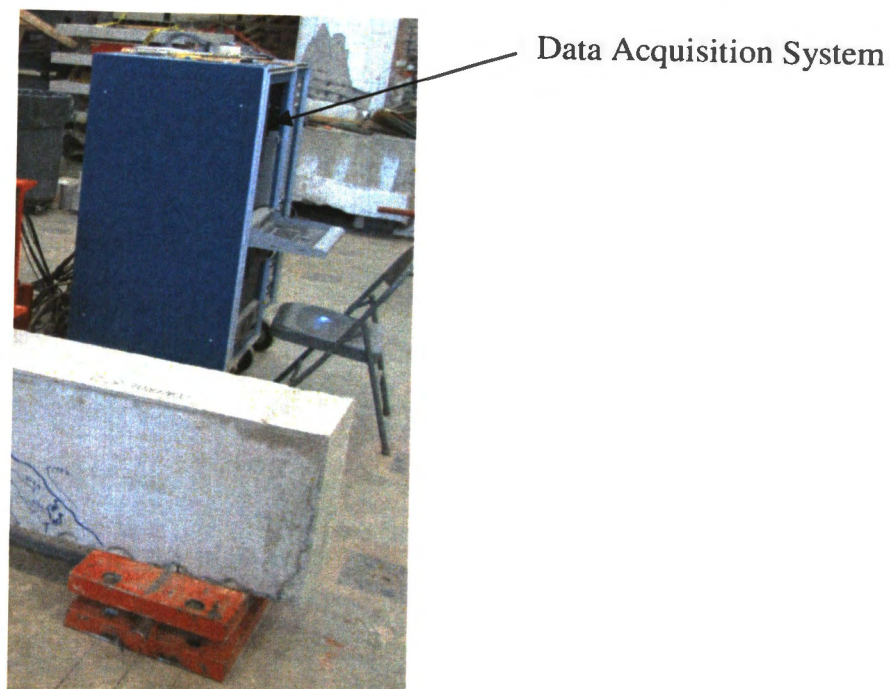

Figure 6.22. Data Acquisition System

6.4.2. Test setup. The span and loading arrangement is shown in Figure 6.23. The beam was supported by two rollers, shown in Figure 6.24, located 1 ft. (305 mm) from the ends of the beam to ensure adequate end bearing and anchorage of the flexural reinforcement. The load was applied to the beam as indicated by the arrows in Figure 6.23 at a distance of 5 ft. (1524 mm) from each end, or 4 ft. (1219 mm) from the support. Figure 6.24 shows the test setup from the front, and Figure 6.25 shows a side view of the setup.

During testing, load was applied by both actuators. It was carried through the cross-beam to the spreader beam until it was applied to the rollers and eventually the beam. This is shown in Figure 6.24. It was seen early during testing that the capacity of the beams approached the capacity of a single actuator, so a second actuator was required

to ensure that testing could be completed. This required the use of the steel cross-beam to transfer the load to the spreader beam.

Several different testing protocols were available for testing. The protocol that was selected directed the actuators to apply load to the beam until a deflection of 0.05 in. (1.27 mm) was achieved. At this point, the actuators stopped and held their position while researchers observed and marked any cracks that had formed in the concrete. Photos were taken for the purpose of data analysis at a later time. When all personnel were safely away from the beam and photos had been taken, the actuators applied load again until the beam deflected an additional 0.05 in. (1.27 mm). This process continued until the beam continued to deflect but the actuators could not apply additional load. At this point, the data was saved, the actuators raised, and the failed beam was removed.

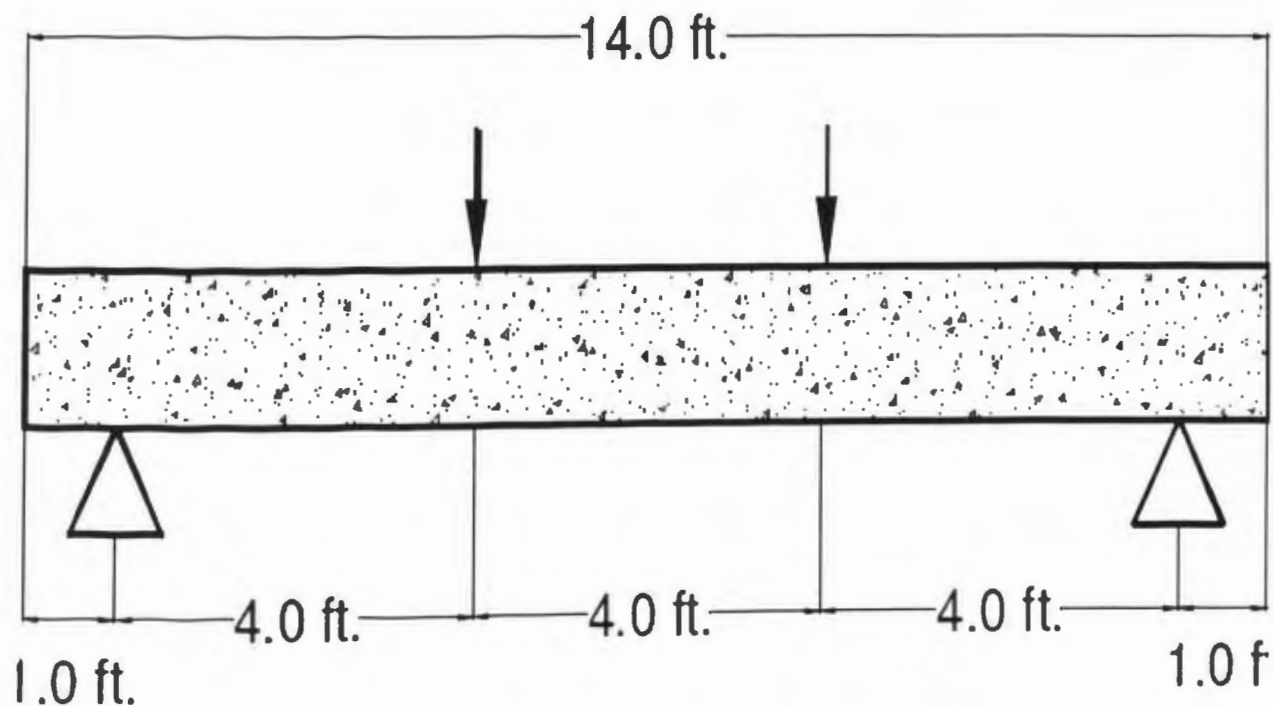

Figure 6.23. Loading Locations for Full-Scale Shear Specimens

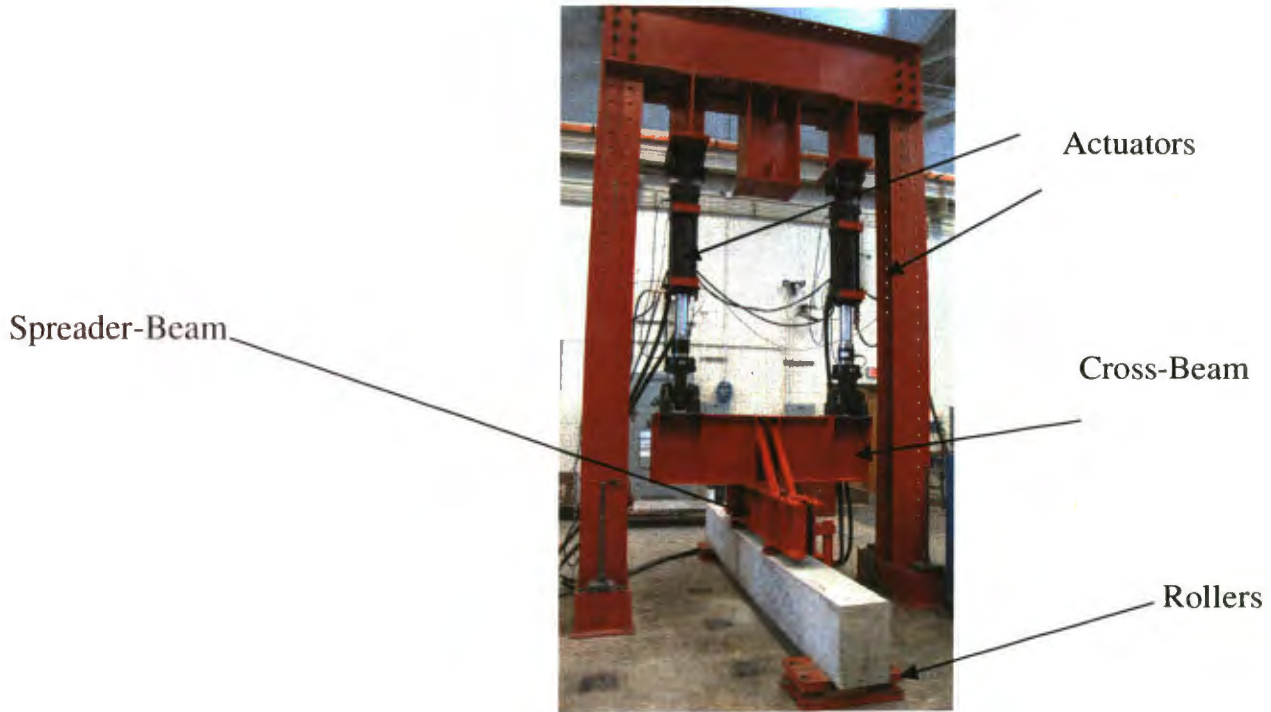

Figure 6.24. Shear Test Setup – Front View

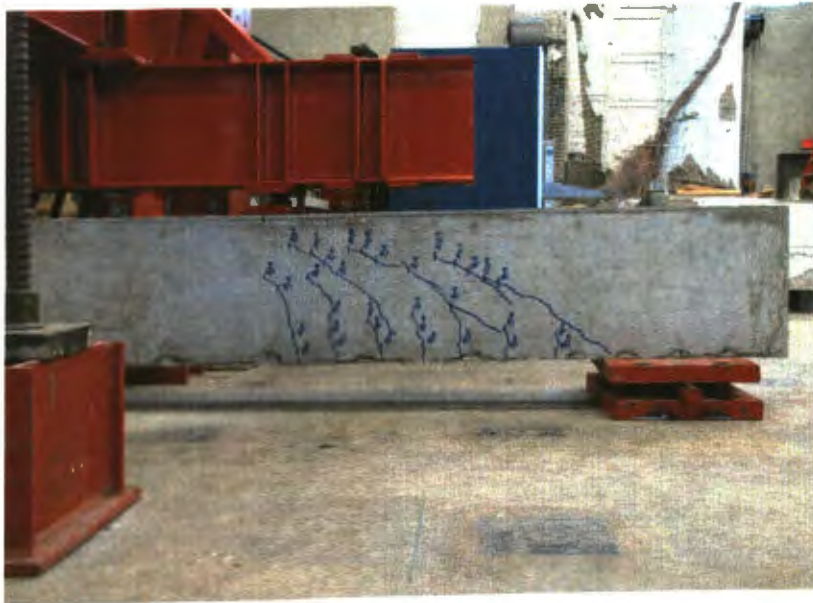

Figure 6.25. Shear Test Setup – Side View

6.5. MATERIAL STRENGTH TESTING AND RESULTS

This section contains the results of material testing for the full-scale beam shear specimens. This included tensile strength testing of the reinforcing steel and compressive strength testing of the concrete.

6.5.1. Tensile strength of reinforcing steel. Tensile strength testing of the reinforcing steel was performed in accordance with ASTM E8-09, “Standard Test Methods for Tension Testing of Metallic Materials” (ASTM E8, 2009). The specimens used for testing were No. 3, No. 4, and No. 8 bars, 8in. (1220 mm) in length. The specimens were obtained from the same shipment that was used to construct the reinforcement cages for the full-scale specimens. The reinforcing specimens were tested on the Tinius-Olsen testing machine in the Construction Materials Load Frame Laboratory located in the Butler-Carlton Civil Engineering Hall. Specimens were loaded continuously and without shock to the breaking point.

The tensile strength test for the reinforcement steel was conducted in accordance with ASTM E8. The specific method that was used was the 0.5 percent offset method. Steel was ordered to have a strength of 60,000 psi (430 MPa), and this test was performed to ensure that steel used met this requirement and so that the actual yield strength would be used in evaluating the response of the beams. All reinforcement met the minimum 60,000 psi (430 MPa) yield strength, and the results are shown in Table 6.4.

6.5.2. Compressive Strength of Concrete. Compression testing was performed in accordance with ASTM C39-10, “Standard Test method for Compressive Strength of Cylindrical Concrete Specimens” (ASTM C39, 2010). The specimens used for this were 4-in.-diameter (100 mm) by 8-in.-long (200 mm) cylinders cast in the Concrete Laboratory of Butler-Carlton Hall (CLBCH). Testing was conducted in the Load Frame Room of Butler-Carlton Hall (LFBCH). The testing apparatus used was a 1200 kip (5,340 kN) Forney Compression Machine. The load was applied continuously and without shock to the specimen at a rate of 35 ± 7 psi/s (0.25 ± 0.05 MPa/s). Based on the specimen size, this would correspond to a loading rate of 440 ± 188 lbs per second (1.9 ± 0.8 kN/s).

A total of 9 cylinders were cast for each set of beams poured. All specimens were cast in plastic cylinder molds with caps and stored beneath plastic so they would experience the same atmospheric conditions as the beams. The specimens were removed from their molds at the same time as the beams, marked and placed beside the beams to cure until the day of testing. The results of the compression testing can be seen in Table 6.5.

Table 6.4. Tensile Strength of Steel

Bar Size	Specimen Number	Yield Strength (psi)
No. 3	1	68450
	2	66900
	3	67900
Average		67750
Standard Deviation		785
COV		1.1%
No. 4	1	65000
	2	65650
	3	64000
Average		64880
Standard Deviation		830
COV		1.2%
No. 8	1	71750
	2	71100
	3	71800
Average		71550
Standard Deviation		390
COV		0.5%

1 psi = 0.006 MPa

Table 6.5. Concrete Compressive Strength

Specimen	Test-day f'_c (psi)	Average (psi)	COV (%)
Control-NS	7270	7330	0.7
	7370		
	7350		
Control-7	6890	7210	4.5
	7540		
	7200		
Control-5	5990	5610	5.9
	5460		
	5380		
SCC-NS	8580	8743	2.2
	8950		
	8700		
SCC-7	7680	8130	4.9
	8260		
	8450		
SCC-5	7370	7420	1.7
	7560		
	7330		

1 psi = 0.006 MPa

6.6. TEST RESULTS

Shear testing of the NC and SCC beams was performed in SERLBCH, and data was collected and stored using a data acquisition system. This section contains the results of those tests. To begin, the loads for both actuators was plotted against the deflection of the beam. Plots for load vs. deflection are in Figures 6.26 through 6.31.

The variables that were tested for shear strength were the type of concrete (SCC or NC) and the amount of shear reinforcement. Three beams were tested at each reinforcement level.

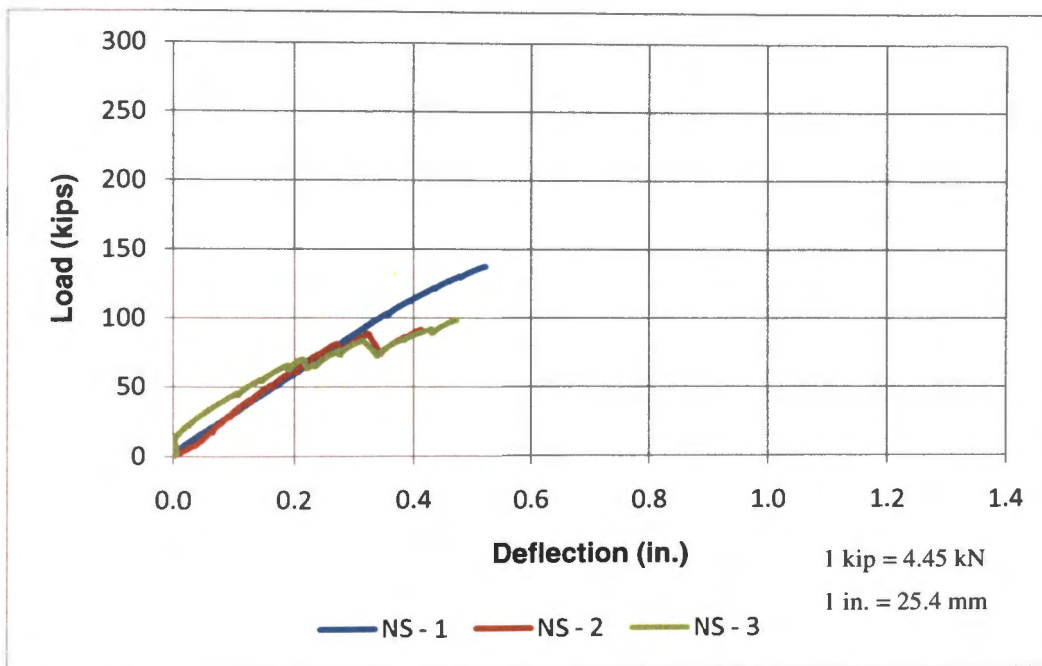

Figure 6.26. Load vs. Deflection Plot for NC – No Stirrups

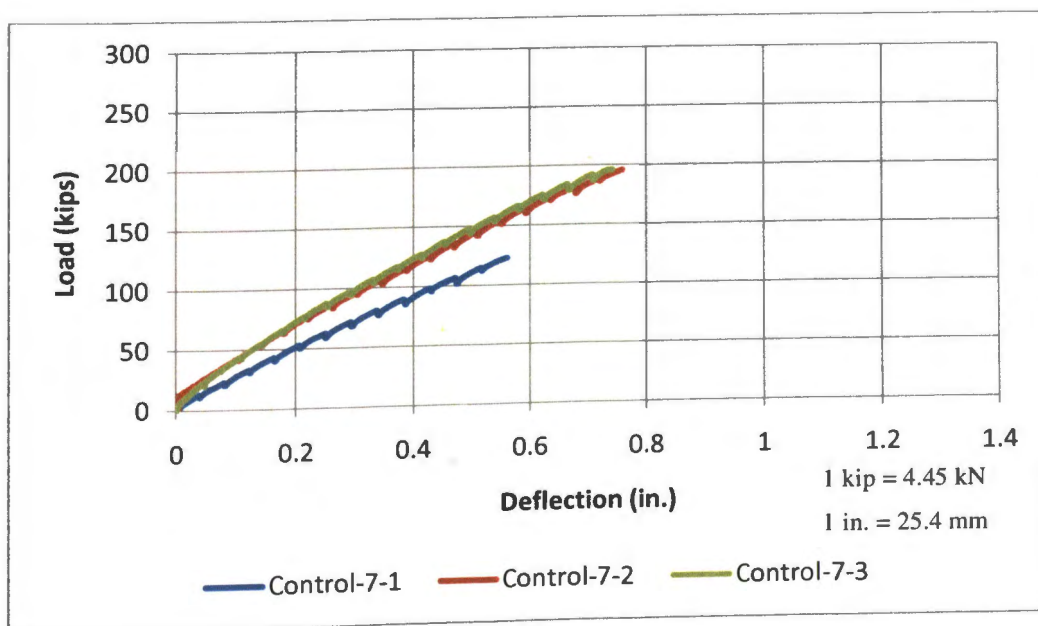

Figure 6.27. Load vs. Deflection Plot for NC – 7 in. Spaced Stirrups

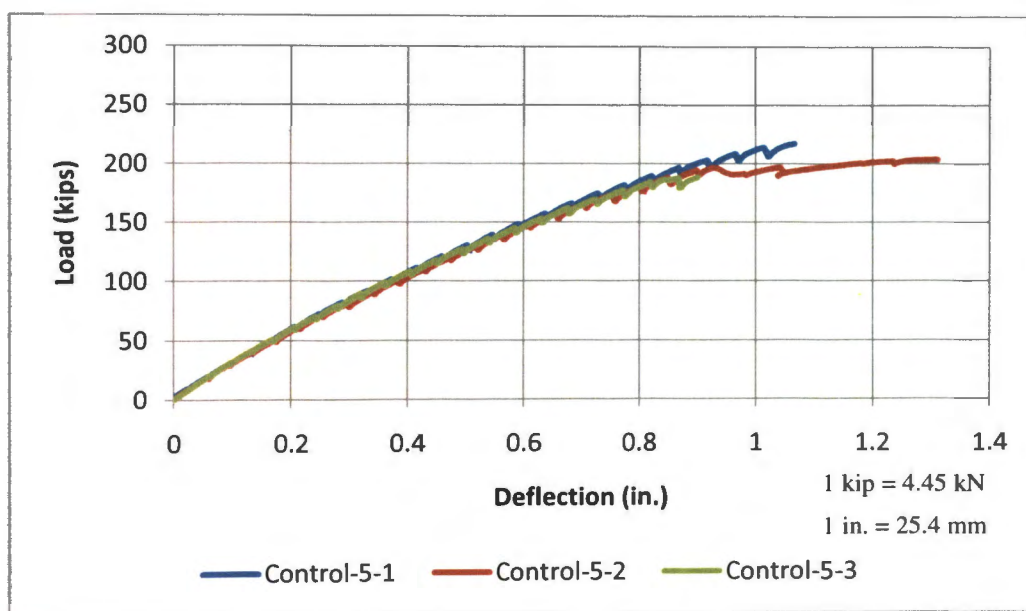

Figure 6.28. Load vs. Deflection Plot for NC – 5-in. Spaced Stirrups

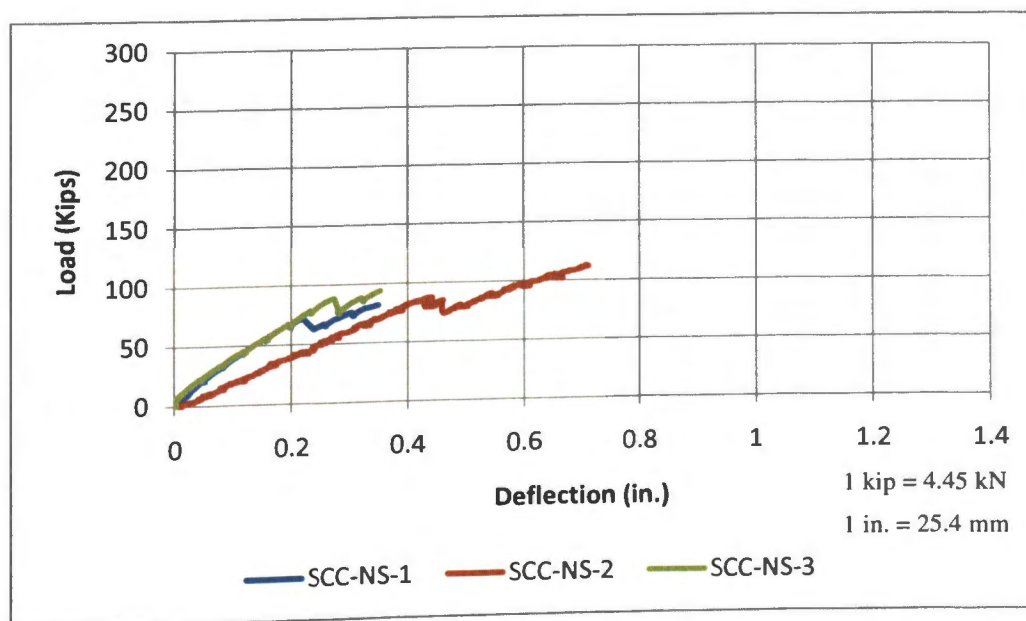

Figure 6.29. Load vs. Deflection Plot for SCC – No Stirrups

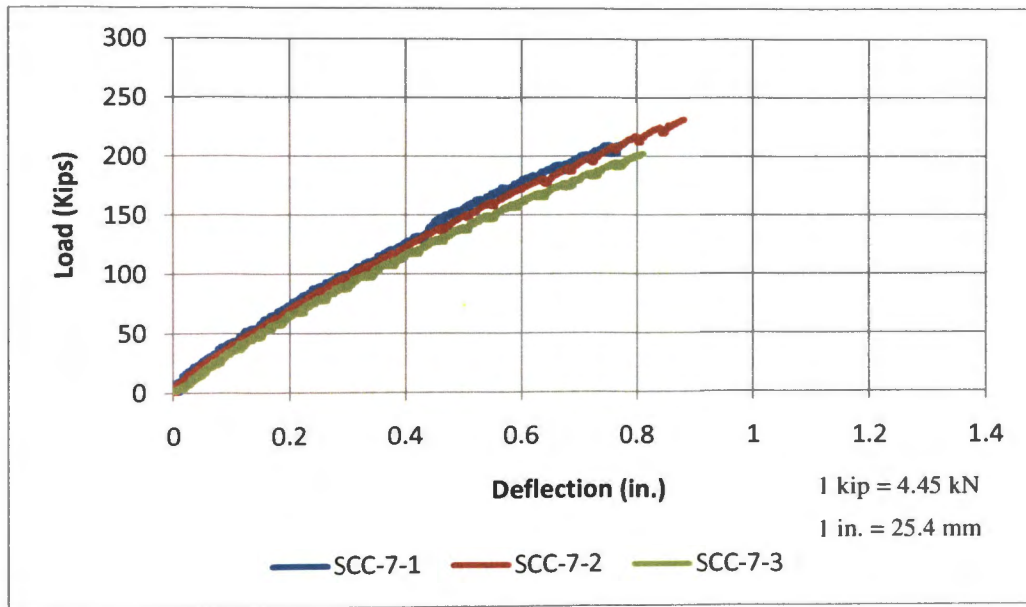

Figure 6.30. Load vs. Deflection Plot for SCC – 7 in. Spaced Stirrups

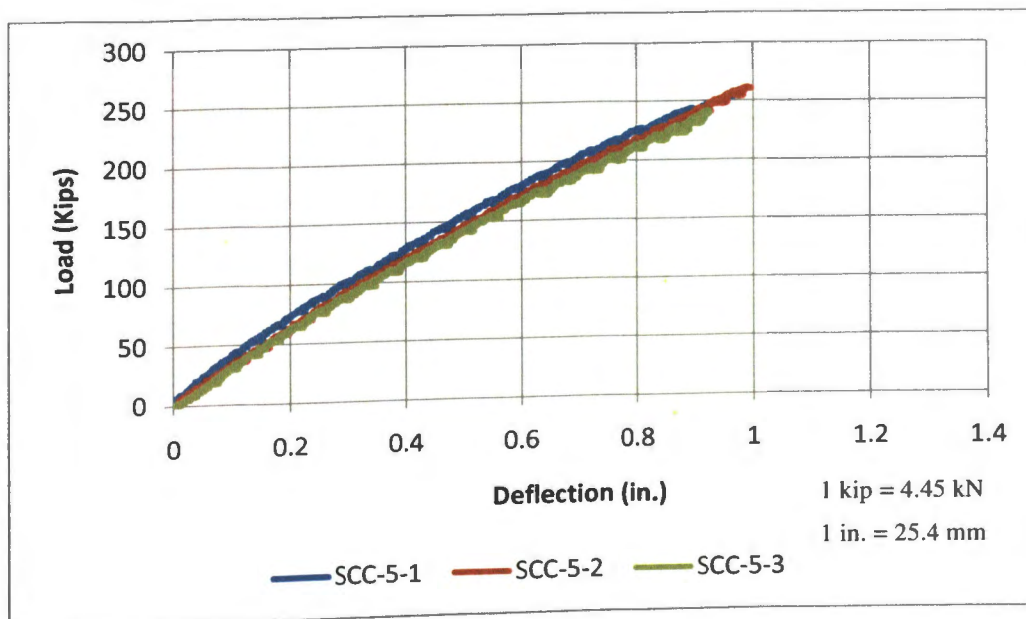

Figure 6.31. Load vs. Deflection Plot for SCC – 5 in. Spaced Stirrups

Table 6.5 contains the shear force carried by each beam tested as well as the shear force contributed by the steel reinforcement and the concrete. The shear force from the steel reinforcement was determined by observing the number of stirrups crossing the critical (failure) shear crack and summing the forces in those stirrups as determined from the measured strains (*e.g.*, Hawkins *et al.*, 2005; Kuchma, 2009; Laskar *et al.*, 2010). The shear force due to the concrete was then determined by subtracting the stirrup force from the total shear force. Figure 6.32 shows graphically the shear strength of the concrete for each of the shear reinforcement scenarios as well as for both concrete types. However, it should be noted for comparison purposes that the SCC concrete strength exceeded the NC concrete strength, as shown in Table 6.6.

To examine how aggregate interlock may have affected the shear resistance of the concrete, the shear force at development of the first diagonal shear crack, V_d , and the shear force at failure, V_u , were recorded for further analysis. The shear force at the development of the first diagonal shear crack was determined by visual inspection of the concrete. When the first crack became visible the load was recorded. The analysis is contained in Section 6.7, but the values determined during testing are shown in Table 6.7.

To find the contribution that the steel had on the shear strength of the beam it was first necessary to find and plot the strain of the stirrups. A typical plot of the strain in the stirrups is shown in Figure 6.33. The steel was assumed to have yielded if the strain was greater than 0.0023. This value was determined by dividing the tensile strength of the steel, determined through testing (see Section 6.5), by the modulus of elasticity of steel. The plot below shows that the steel did in fact yield since the strain was greater than 0.0023.

In addition to studying the strain within the steel, the crack patterns experienced by the beams were also observed. It was seen that generally the degree of cracking increased as the amount of stirrups increased. During testing, cracks were marked using a permanent marker after each deflection of 0.05 in. (1.27 mm). A typical crack pattern progression can be seen in Figures 6.34 through 6.37 for beams constructed with NC, and in Figures 6.38 through 6.42 for beams constructed with SCC. For both cases, cracks typically began on the tension face of the beam near the loading points. As the cracks

began to increase in size, they also began to slant at an angle approximately 30 to 45 degrees measured from the bottom of the beam to the crack. Typically at failure, the cracks were spaced approximately the same distance as the stirrups and failure occurred on one side of the beam. The failure crack typically extended from the beam support to the loading point on the top side of the beam. Figures 6.43 through 6.60 are photographs of each of the test specimens after failure.

Table 6.6. Tested Shear Strength

Specimen	Stirrup Spacing (in.)	Shear Force (kip)		
		V	V _s	V _c
Control-NS-1	No Stirrups	68.6	0.0	68.6
Control-NS-2		45.8	0.0	45.8
Control-NS-3		49.1	0.0	49.1
Control-7-1	7	61.3	29.8	31.4
Control-7-2		97.6	44.7	52.9
Control-7-3		97.9	44.7	53.1
Control-5-1	5	108.5	59.6	48.8
Control-5-2		101.8	44.7	57.1
Control-5-3		94.1	59.6	34.4
SCC-NS-1	No Stirrups	40.9	0.0	40.9
SCC-NS-2		56.2	0.0	56.2
SCC-NS-3		46.9	0.0	46.9
SCC-7-1	7	105.3	44.7	60.6
SCC-7-2		115.6	29.8	85.8
SCC-7-3		101.0	44.7	56.3
SCC-5-1	5	126.6	59.6	67.0
SCC-5-2		130.7	59.6	71.1
SCC-5-3		120.8	44.7	76.1

1 kip = 4.45 kN

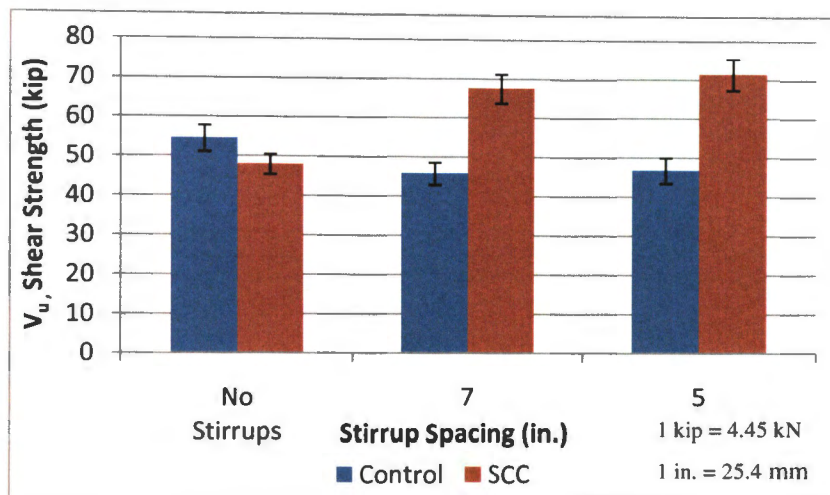

Figure 6.32. Concrete Shear Strength Plot

Table 6.7. V_u and V_d Values

Specimen	Stirrup Spacing (in.)	V_u (kip)	V_d (kip)
Control-NS-1	No Stirrups	68.6	32.5
Control-NS-2		45.8	22.0
Control-NS-3		49.1	25.0
Control-7-1	7	61.3	21.0
Control-7-2		97.6	21.5
Control-7-3		97.9	15.5
Control-5-1	5	108.5	15.0
Control-5-2		101.8	14.5
Control-5-3		94.1	19.5
SCC-NS-1	No Stirrups	40.9	22.0
SCC-NS-2		56.2	21.5
SCC-NS-3		46.9	21.5
SCC-7-1	7	105.3	18.5
SCC-7-2		115.6	20.5
SCC-7-3		101.0	24.5
SCC-5-1	5	126.6	22.0
SCC-5-2		130.7	24.0
SCC-5-3		120.8	21.5

1 kip = 4.45 kN

1 in. = 25.4 mm

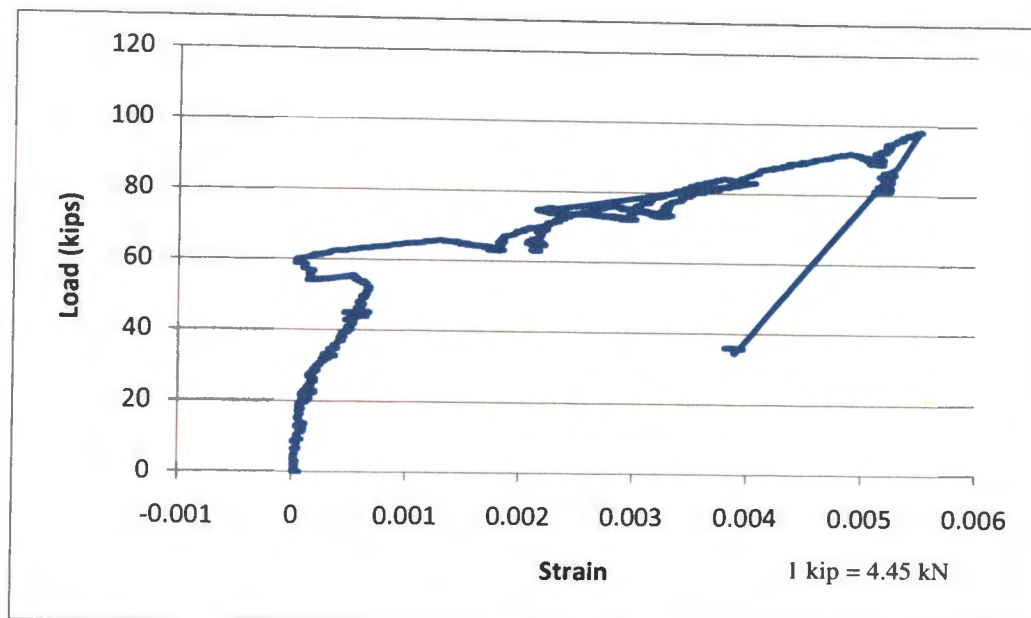

Figure 6.33. Typical Stirrup Strain Plot as a Function of Load

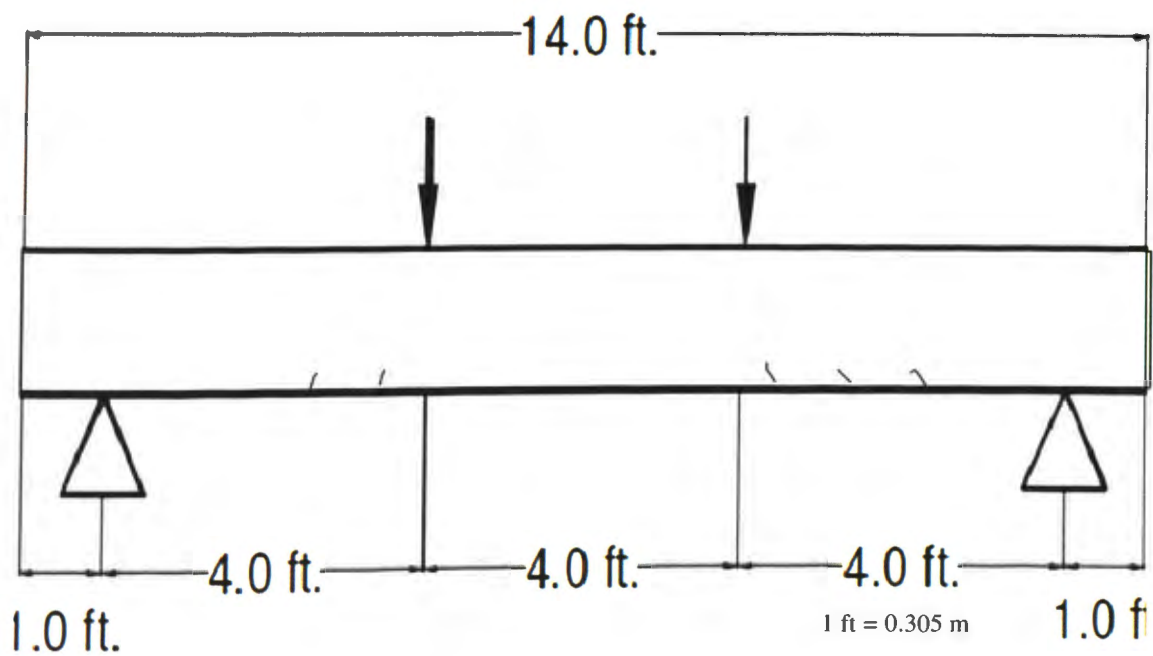

Figure 6.34. Typical Crack Pattern for NC – Stage 1

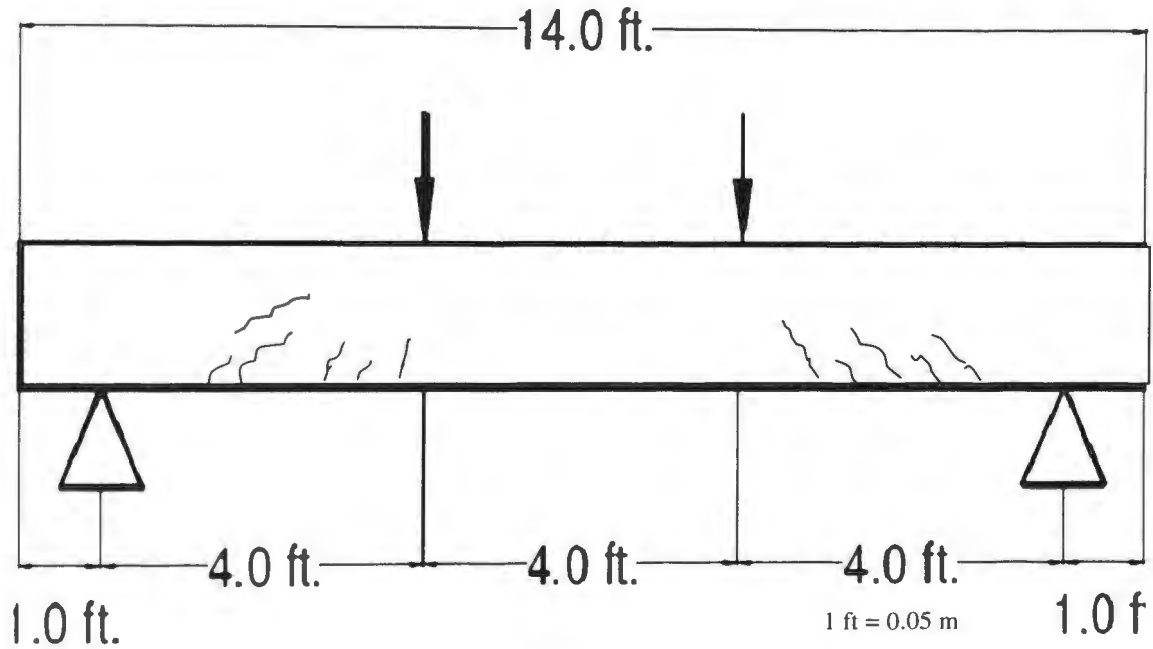

Figure 6.35. Typical Crack Pattern for NC – Stage 2

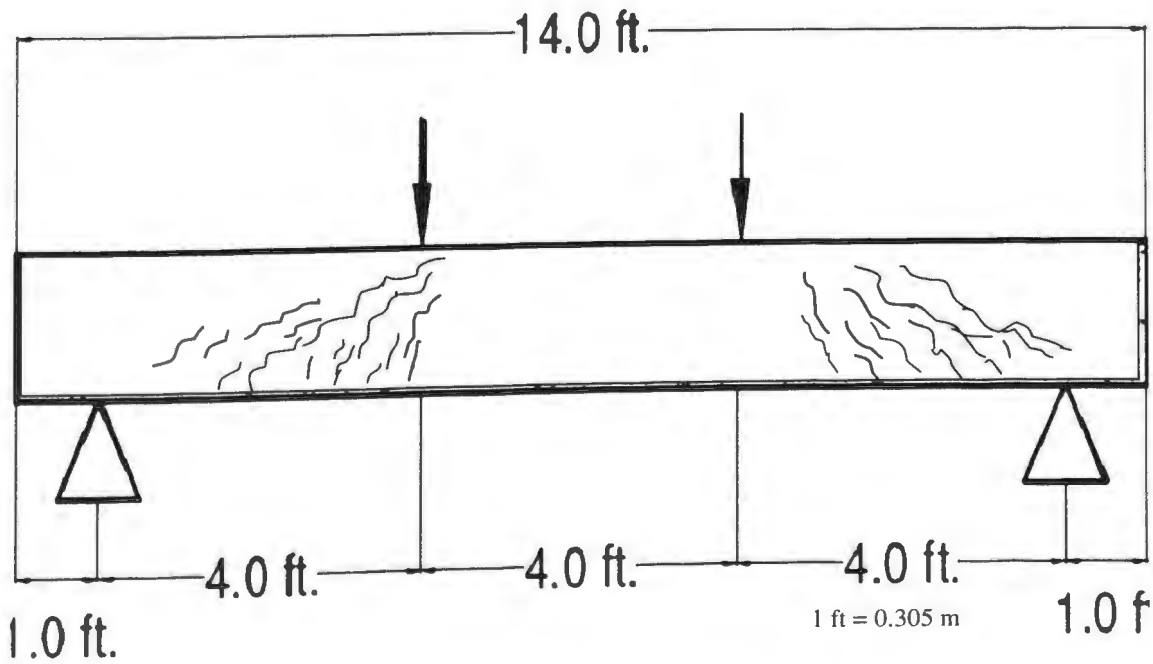

Figure 6.36. Typical Crack Pattern for NC – Stage 3

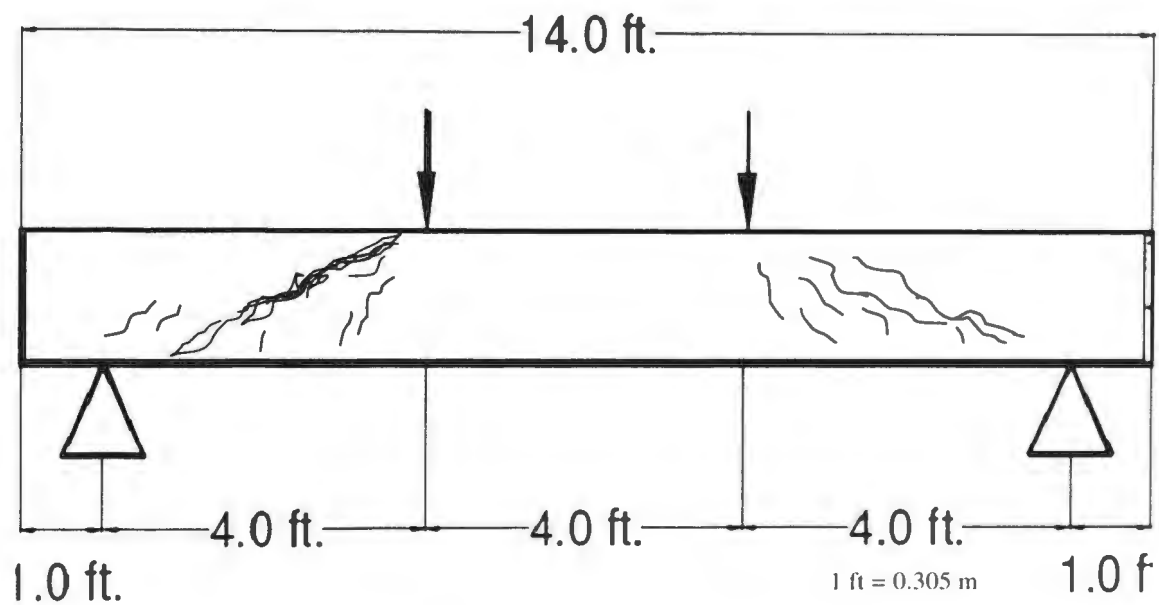

Figure 6.37. Typical Crack Pattern for NC – Stage 4

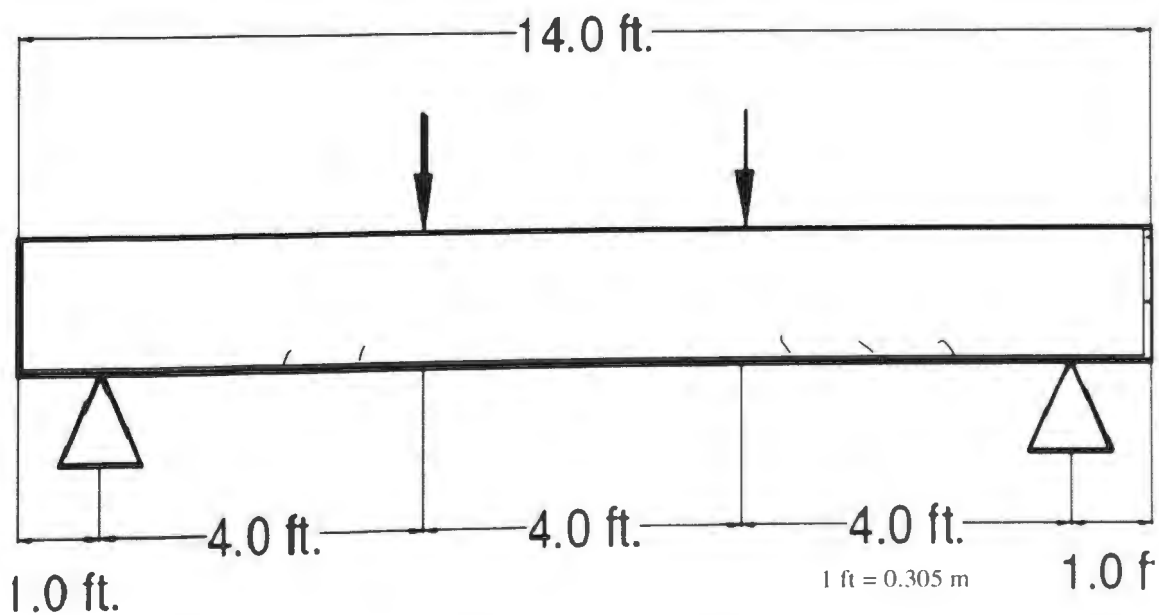

Figure 6.38. Typical Crack Pattern for SCC – Stage 1

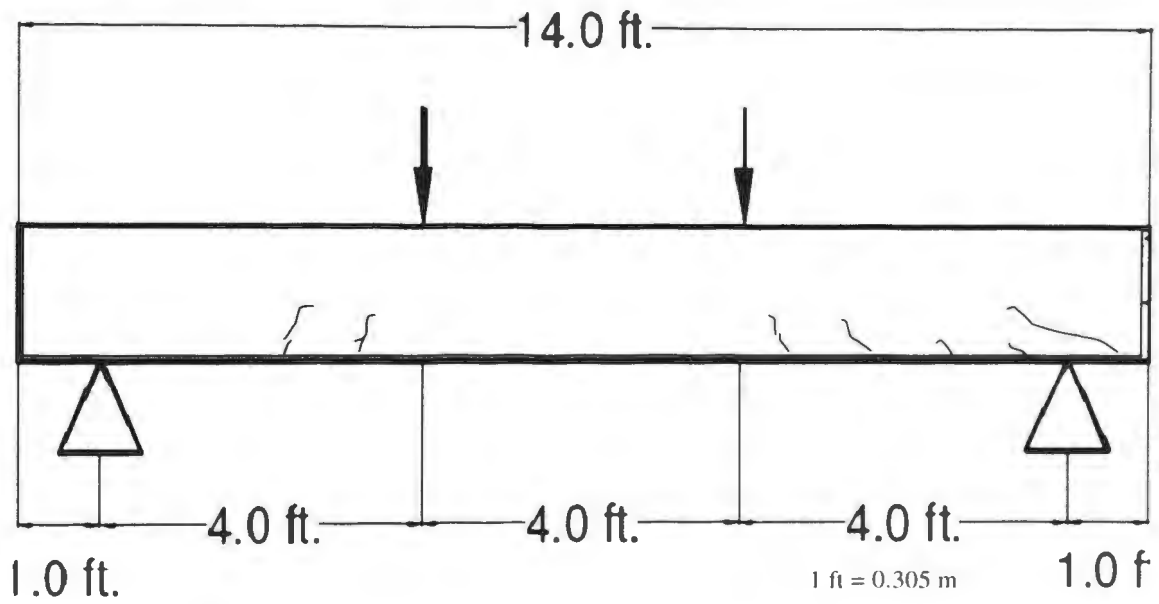

Figure 6.39. Typical Crack Pattern for SCC – Stage 2

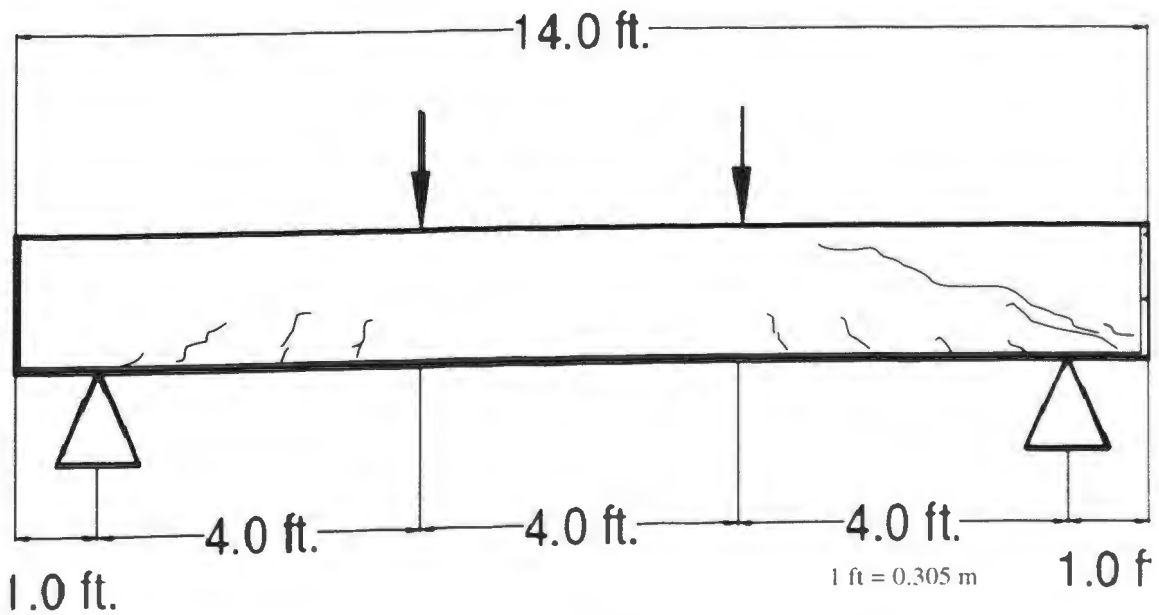

Figure 6.40. Typical Crack Pattern for SCC – Stage 3

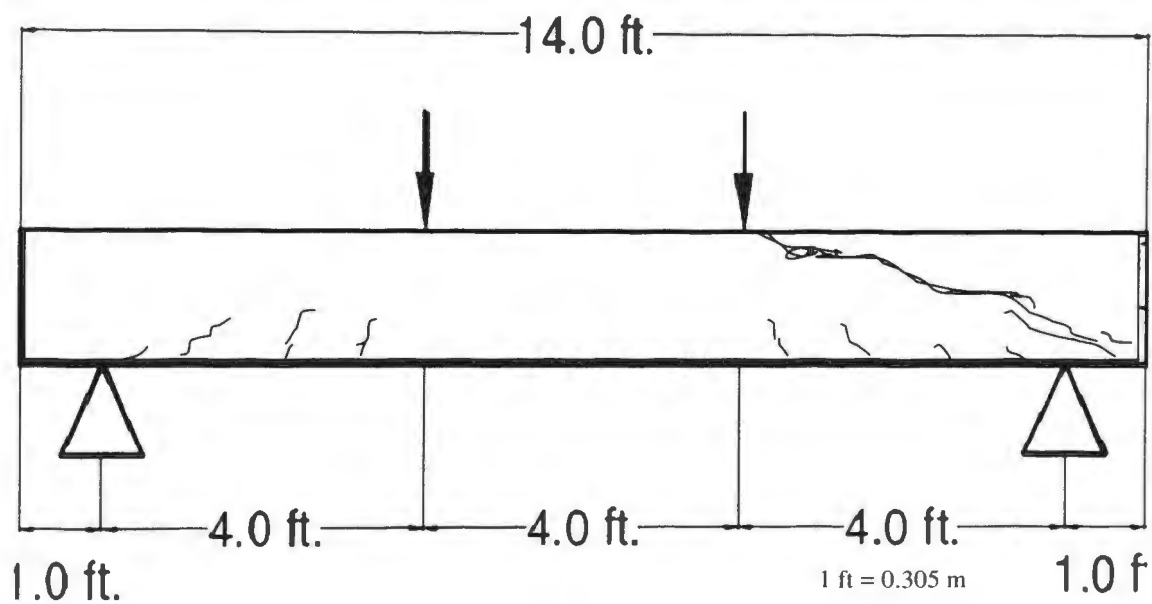

Figure 6.41. Typical Crack Pattern for SCC – Stage 4

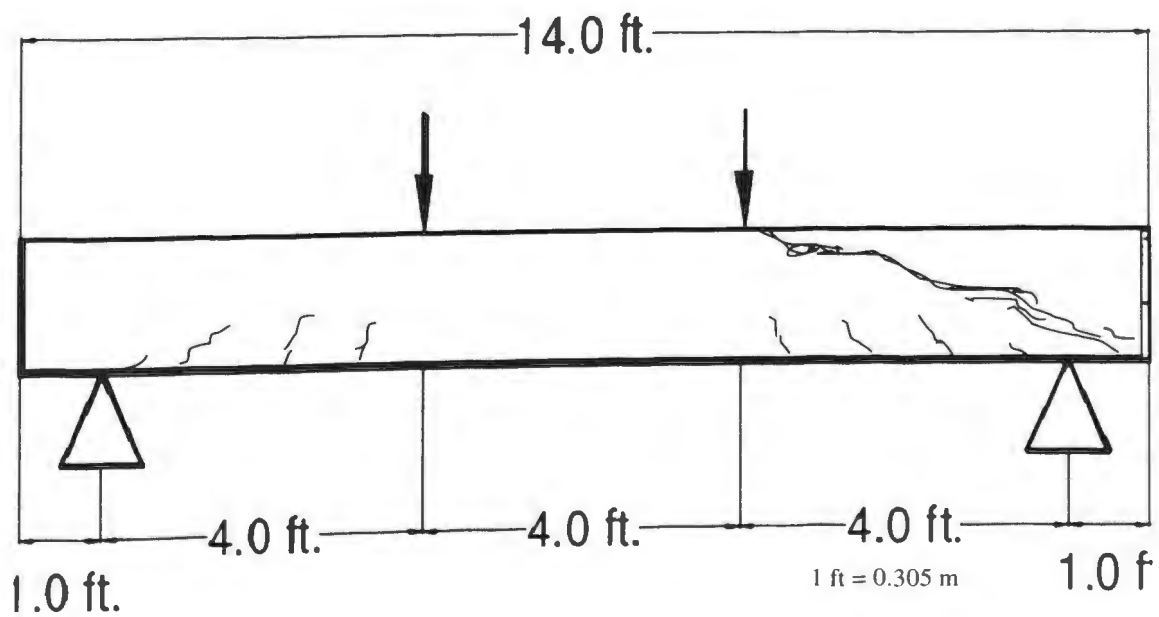

Figure 6.42. Typical Crack Pattern for SCC – Stage 5



Figure 6.43. Control-NS-1 Beam at Failure



Figure 6.44. Control-NS-2 Beam at Failure



Figure 6.45. Control-NS-3 Beam at Failure



Figure 6.49. Control-5-1 Beam at Failure



Figure 6.50. Control-5-2 Beam at Failure

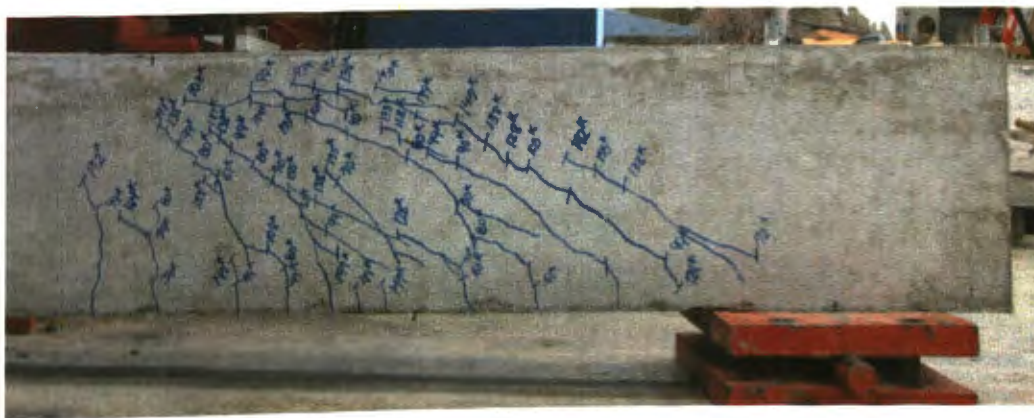

Figure 6.51. Control-5-3 Beam at Failure

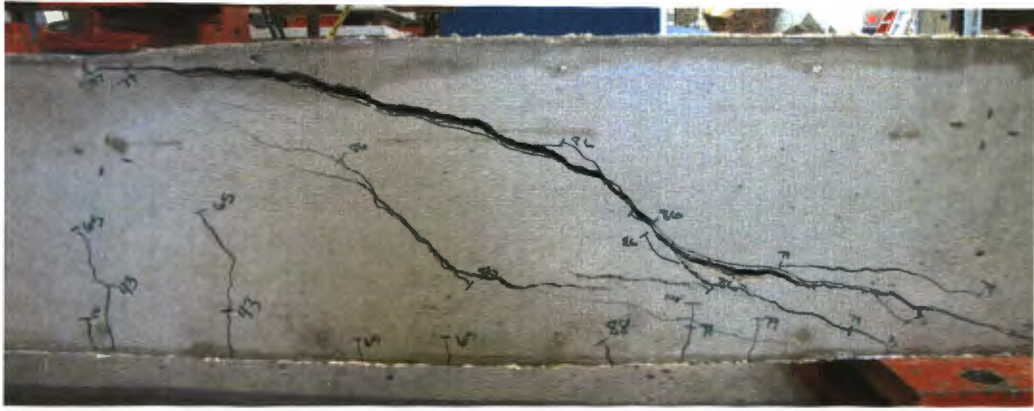

Figure 6.52. SCC-NS-1 Beam at Failure



Figure 6.53. SCC-NS-2 Beam at Failure



Figure 6.54. SCC-NS-3 Beam at Failure



Figure 6.55. SCC-7-1 Beam at Failure



Figure 6.56. SCC-7-2 Beam at Failure



Figure 6.57. SCC-7-3 Beam at Failure

6.7. DATA ANALYSIS AND INTERPRETATION

Data analysis began by first examining the load-deflection plots as shown in Figures 6.26 through 6.31. In general, the load-deflection plots indicated a linear relationship between the load and deflection for the shear specimens. This behavior would indicate a shear failure as opposed to a flexural failure. It was also noted during testing that there was often little warning before the beam failed. This sudden failure translated to the graphs as a continually increasing load compared with the deflection until failure at which point the load dropped suddenly. It was observed that as the amount of shear reinforcement increased, the load at which the beams failed also increased.

To determine the contribution of the stirrups to the overall shear strength of the beams, it was necessary to plot the load-strain values for the stirrups within each specimen. Figure 6.33 is an example of one of these plots. It can be seen that initially there is not a significant amount of strain within the stirrup. As the load applied to the beam continues to increase, the stirrup begins to go into tension at approximately V_d . This would seem to indicate that at this point, the concrete can no longer carry the entire load and must rely, at least partially, on the stirrups for strength. As load continues to be applied, the stirrups eventually yield. This happens when the strain in the steel is greater than 0.0023. For a vast majority of the beams, the stirrups yielded prior to failure of the beam. For the stirrups that did not yield, the yield strength of the steel could not be used to estimate V_s . Instead, the measured strain at failure was multiplied by the modulus of elasticity of the steel to determine the load that the stirrup supported at failure. Values used to determine the contribution of the stirrups to shear strength are shown in Table 6.8.

In order to compare the shear strength that was determined through testing with the shear strength that was predicted by ACI (2008) and AASHTO (2008), the ratio of the test value to the predicted value was calculated. This ratio is given in Table 6.9 and is based on the actual material properties for concrete strength and stirrup yield strength. Ideally, the ratio would be greater than 1.0, which would indicate that the shear strength was conservatively predicted by the codes. The ratios were calculated for three different

design equations. The first two were based on ACI Equations 11-3 and 11-5 (ACI 318, 2008).

Table 6.8. Calculation of V_s

Specimen	# Stirrups Crossed	A_v (in ²)	V_s (kip)
Control-NS-1	0	0	0.0
Control-NS-2	0	0	0.0
Control-NS-3	0	0	0.0
Control-7-1	2	0.44	29.8
Control-7-2	3	0.66	44.7
Control-7-3	3	0.66	44.7
Control-5-1	4	0.88	59.6
Control-5-2	3	0.66	44.7
Control-5-3	4	0.88	59.6
SCC-NS-1	0	0	0.0
SCC-NS-2	0	0	0.0
SCC-NS-3	0	0	0.0
SCC-7-1	3	0.66	44.7
SCC-7-2	2	0.44	29.8
SCC-7-3	3	0.66	44.7
SCC-5-1	4	0.88	59.6
SCC-5-2	4	0.88	59.6
SCC-5-3	3	0.66	44.7

1 kip = 4.45 kN

1 in. = 25.4 mm

The third set of ratios was based on the sectional analysis in the AASHTO LRFD Code (2008). As shown in Table 6.7, ACI Equation 11-3 and AASHTO were conservative throughout testing with ratios consistently greater than 1.0. However, ACI Equation 11-5 was not always conservative since there were ratios less than 1.0 in some

cases. However, the very large amount of longitudinal steel (4.5%) is likely the reason that the ratio is less than 1.0 for ACI Equation 11-5. More importantly, both the NC and SCC beams had similar ratios when using ACI Equation 11-5. This would seem to indicate that when comparing the two concrete types, the SCC performed as well as the NC.

Table 6.9. V_{test} / V_{code}

Specimen	Stirrup Spacing (in.)	V_{test} (kip)	V_{test} / V_{code}		
			ACI Eq. 11-3	ACI Eq. 11-5	AASHTO
Control-NS-1	No Stirrups	68.6	2.3	1.3	2.3
Control-NS-2		45.8	1.5	0.9	1.5
Control-NS-3		49.1	1.6	0.9	1.6
Control-7-1	7	61.3	1.0	0.7	1.1
Control-7-2		97.6	1.6	1.2	1.7
Control-7-3		97.9	1.6	1.2	1.7
Control-5-1	5	108.5	1.6	1.2	1.7
Control-5-2		101.8	1.5	1.1	1.6
Control-5-3		94.1	1.3	1.0	1.4
SCC-NS-1	No Stirrups	40.9	1.2	0.7	1.2
SCC-NS-2		56.2	1.7	1.0	1.7
SCC-NS-3		46.9	1.4	0.8	1.4
SCC-7-1	7	105.3	1.7	1.2	1.8
SCC-7-2		115.6	1.8	1.3	1.9
SCC-7-3		101.0	1.6	1.2	1.7
SCC-5-1	5	126.6	1.7	1.3	1.8
SCC-5-2		130.7	1.8	1.4	1.9
SCC-5-3		120.8	1.6	1.3	1.7

1 kip = 4.45 kN

1 in. = 25.4 mm

After comparing the total shear strength for each of the beams, the shear strength of the concrete was evaluated for both the specimens without transverse reinforcement and those with transverse reinforcement. The result is shown in Table 6.10 and graphically in Figure 6.61. The test value for V_c was calculated by subtracting V_s from V , where the value of V_s was determined through testing. The values predicted by ACI Equation 11-3 were 1.1 to 2.7 times smaller than the values determined through testing, indicating that for these specimens, ACI Equation 11-3 was conservative. The values for the shear strength of concrete determined using ACI Equation 11-5 were not always conservative since some ratios were less than 1.0. This result would indicate that the shear strength predicted using this equation exceeded the shear strength determined through testing. However, this result may have been a function of the very large amount of longitudinal steel (4.5%). It was noted, however, that ratios of the tested shear strength to code predicted shear strength were less than 1.0 for both the NC and the SCC, and the ratios were relatively consistent between the two types of concrete. This result could indicate that the SCC performed as well as the NC. Finally, concrete shear strengths determined through testing were consistently higher than the concrete shear strengths predicted using the AASHTO equation. This would seem to indicate that designing with this set of equations would be conservative when determining the shear strength for both NC and SCC.

Table 6.11 offers a direct comparison between the two concrete types by normalizing the concrete contribution as a function of the square root of compressive strength. The tested values listed in the table are repeated from Table 6.5. The last column indicates the normalized value of the tested concrete shear strength. Figure 6.62 is a graphical representation of the same values. The table and figure indicate that with a reinforcement ratio of 4.5%, the normalized value of the tested concrete strength ranged between 2.9 and 4.7. Figure 6.63 is a plot of the extensive amount of test data collected by Tureyen and Frosch (2004) on concrete shear strength as a function of the longitudinal reinforcement ratio, and includes the normalized concrete shear strength values determined in this study. Tureyen and Frosch observed that the coefficient of 2 used in ACI Equation 11-3 to determine the concrete shear strength was not always accurate. In

concrete specimens with small reinforcement ratios, the coefficient could be lower than 2, while very high reinforcement ratios could have coefficients as high as 4 or 5. Figure 6.54 indicates that the normalized coefficients calculated using beams tested during this research were consistent with the extensive amount of previous test data. Once again this would indicate that the shear strength of concrete predicted by ACI is very conservative for beams with high amounts of longitudinal reinforcement.

Table 6.10. Shear Strength From Concrete

Specimen	Stirrup Spacing (in.)	$V_{C \text{ Test}} / V_{C \text{ Code}}$			Test V_c (kip)	Avg. Test V_c (kip)	Coefficient of Variation
		ACI Eq. 11-3	ACI Eq. 11-5	AASHTO			
Control-NS-1	No Stirrups	2.3	1.3	2.3	68.6	54.5	22.6
Control-NS-2		1.5	0.9	1.5	45.8		
Control-NS-3		1.6	0.9	1.6	49.1		
Control-7-1	7	1.1	0.6	1.1	31.4	45.8	27.2
Control-7-2		1.8	1.0	1.8	52.9		
Control-7-3		1.8	1.0	1.8	53.1		
Control-5-1	5	1.9	1.1	1.9	48.8	46.8	24.5
Control-5-2		2.2	1.2	2.2	57.1		
Control-5-3		1.3	0.7	1.3	34.4		
SCC-NS-1	No Stirrups	1.2	0.7	1.2	40.9	48.0	16.1
SCC-NS-2		1.7	1.0	1.7	56.2		
SCC-NS-3		1.4	0.8	1.4	46.9		
SCC-7-1	7	1.9	1.1	1.9	60.6	67.6	23.6
SCC-7-2		2.7	1.5	2.7	85.8		
SCC-7-3		1.8	1.0	1.8	56.3		
SCC-5-1	5	2.2	1.3	2.2	67.0	71.4	6.4
SCC-5-2		2.4	1.3	2.4	71.1		
SCC-5-3		2.5	1.4	2.5	76.1		

1 kip = 4.45 kN

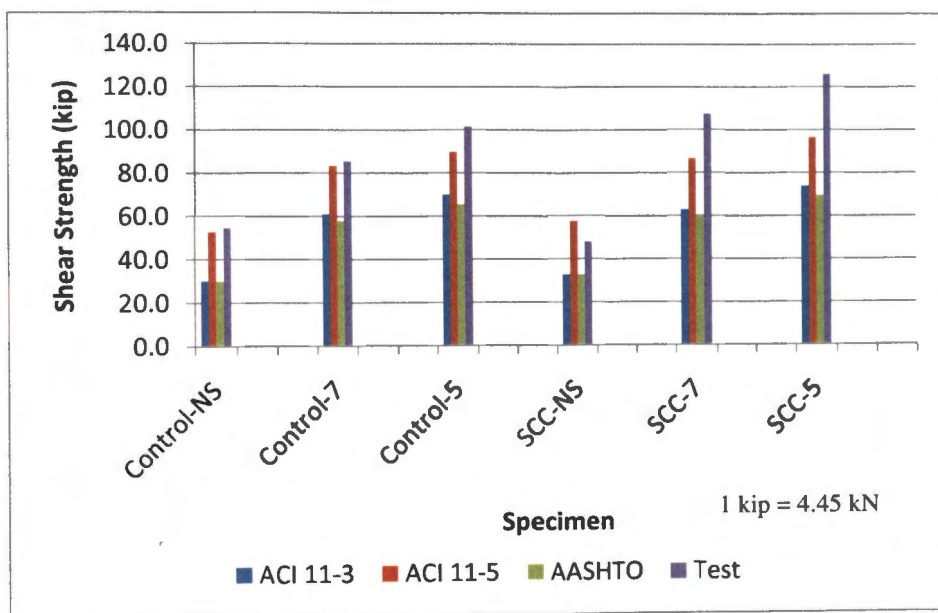

Figure 6.61. Concrete Shear Strength

Table 6.11. Tested Shear Strength Comparison

Specimen	Stirrup Spacing (in.)	Shear Force (kip)				$\frac{V_c \text{ test}}{b_w d \sqrt{f'_c}}$
		V	V _s	V _c	V _c Avg.	
Control-NS-1	No Stirrups	68.6	0.0	68.6	54.5	3.6
Control-NS-2		45.8	0.0	45.8		
Control-NS-3		49.1	0.0	49.1		
Control-7-1	7	61.3	29.8	31.4	45.8	3.1
Control-7-2		97.6	44.7	52.9		
Control-7-3		97.9	44.7	53.1		
Control-5-1	5	108.5	59.6	48.8	46.8	3.6
Control-5-2		101.8	44.7	57.1		
Control-5-3		94.1	59.6	34.4		
SCC-NS-1	No Stirrups	40.9	0.0	40.9	48.0	2.9
SCC-NS-2		56.2	0.0	56.2		
SCC-NS-3		46.9	0.0	46.9		
SCC-7-1	7	105.3	44.7	60.6	67.6	4.3
SCC-7-2		115.6	29.8	85.8		
SCC-7-3		101.0	44.7	56.3		
SCC-5-1	5	126.6	59.6	67.0	71.4	4.7
SCC-5-2		130.7	59.6	71.1		
SCC-5-3		120.8	44.7	76.1		

1 kip = 4.45 kN

1 in. 25.4 mm

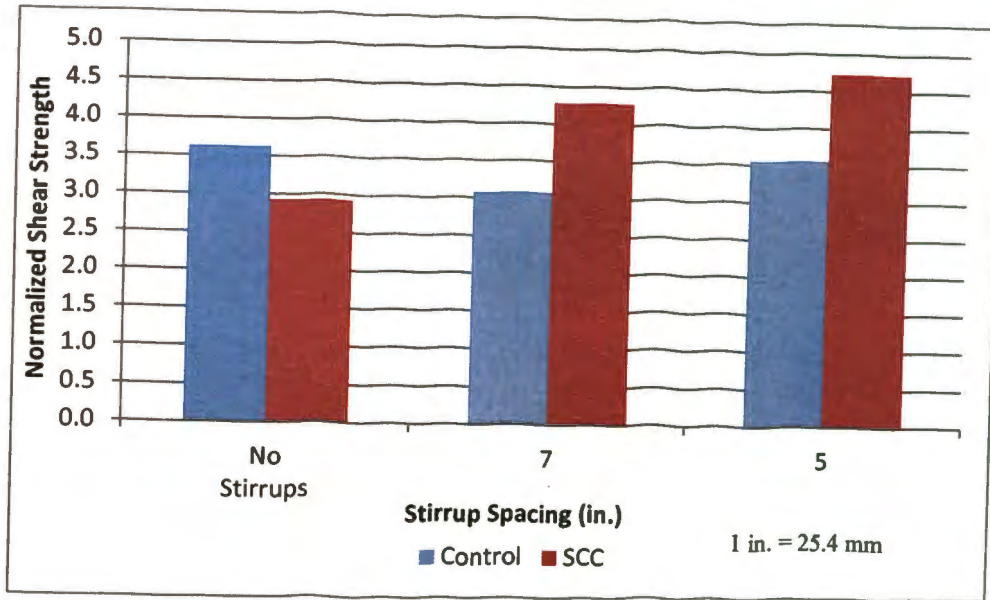

Figure 6.62. Normalized Concrete Shear Strength

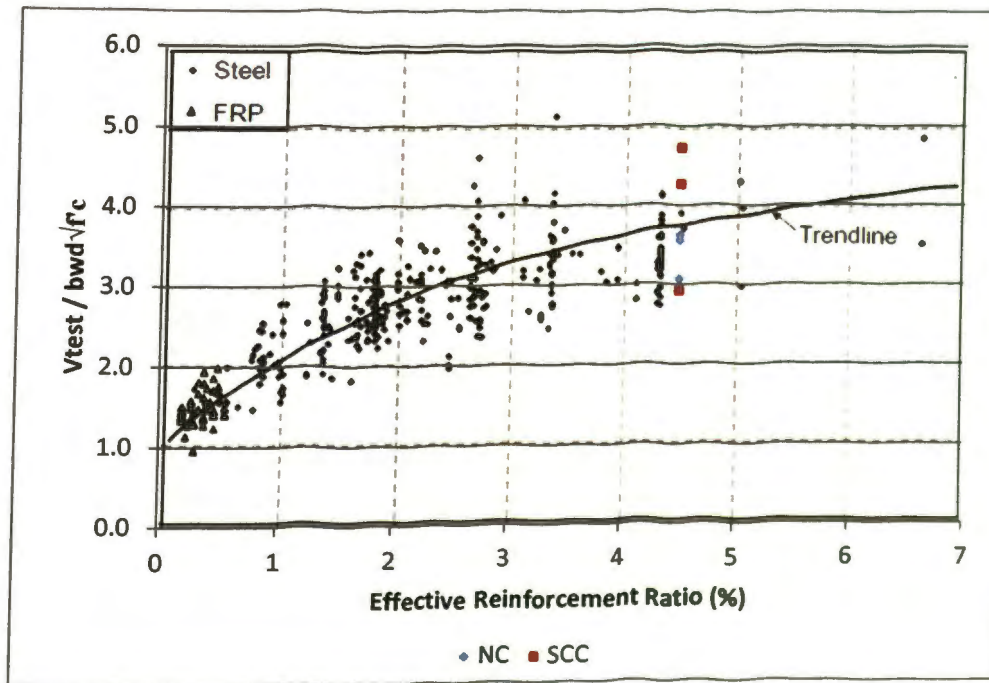

Figure 6.63. Comparison of Current Test Results with Previous Test Data Collected by Tureyen and Frosch (2003)

To examine the effect of aggregate interlock on the shear resistance of the concrete, V_d (development of first diagonal shear crack) and V_u (ultimate shear) were recorded for each test specimen. The ratio of V_u/V_d was then calculated and compared for both types of beams, and this data is shown in Table 6.12. Figure 6.53 is a graphical representation of this ratio. A higher V_u/V_d ratio would indicate that the beam was more ductile and gave an earlier indication of failure before complete collapse. Obviously, this characteristic is extremely beneficial in the event that overloading would occur. More importantly, this ratio offers another comparison of the shear behavior between the two concrete types.

As shown in Figure 6.64, both concrete types followed the same general trend. The value of V_u/V_d increased from 2.1 with no stirrups to 6.4 with the smallest stirrup spacing of 5 in. (127 mm). For the SCC specimens, as the spacing between the stirrups decreased, the ductility also increased. The value of V_u/V_d increased from 2.2 to 5.6. In comparing the response of the two concrete types, the error bars in Figure 6.53 indicate that there was not a significant statistical difference between the NC and SCC specimens. In all three shear reinforcement scenarios, the error bars overlap. It is also worth noting that as the amount of shear reinforcement increased, the value of V_u/V_d also increased, as expected.

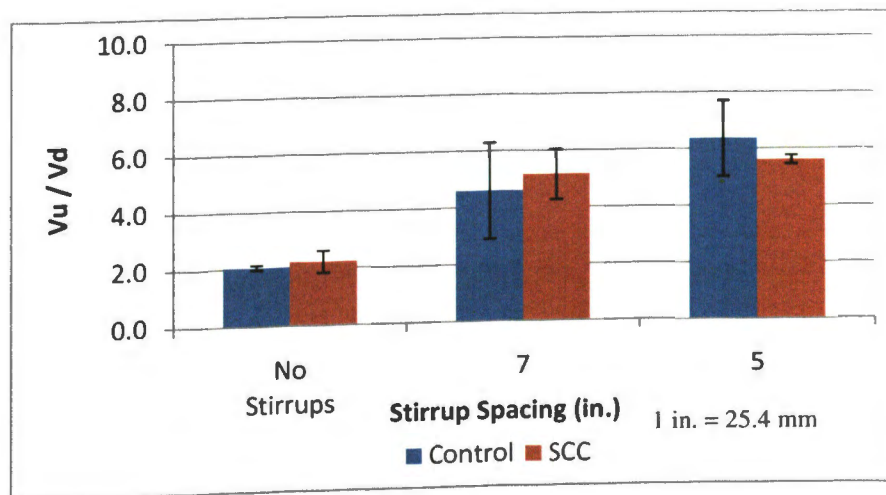

Figure 6.64. V_u/V_d Plot

Table 6.12. V_u/V_d

Specimen	Stirrup Spacing (in.)	V_u (kip)	V_d (kip)	V_u/V_d	Average V_u/V_d	Coefficient of Variation
Control-NS-1	No Stirrups	68.6	32.5	2.1	2.1	3.8
Control-NS-2		45.8	22.0	2.1		
Control-NS-3		49.1	25.0	2.0		
Control-7-1	7.0	61.3	21.0	2.9	4.6	37.0
Control-7-2		97.6	21.5	4.5		
Control-7-3		97.9	15.5	6.3		
Control-5-1	5.0	108.5	15.0	7.2	6.4	21.0
Control-5-2		101.8	14.5	7.0		
Control-5-3		94.1	19.5	4.8		
SCC-NS-1	No Stirrups	40.9	22.0	1.9	2.2	17.1
SCC-NS-2		56.2	21.5	2.6		
SCC-NS-3		46.9	21.5	2.2		
SCC-7-1	7.0	105.3	18.5	5.7	5.2	17.3
SCC-7-2		115.6	20.5	5.6		
SCC-7-3		101.0	24.5	4.1		
SCC-5-1	5.0	126.6	22.0	5.8	5.6	2.8
SCC-5-2		130.7	24.0	5.4		
SCC-5-3		120.8	21.5	5.6		

1 kip = 4.45 kN

6.8. CONCLUSIONS

The test results were compared to ACI (2008) and AASHTO (2008) design provisions for shear. It was observed that both AASHTO and ACI Equation 11-3 were consistently conservative; however, ACI Equation 11-5 over predicted strength. It was also observed that there was not a significant difference in strength when comparing NC and SCC. Shear strengths determined through testing were not significantly different between NC or SCC beams made with the same shear reinforcement. This result would seem to indicate that as far as shear behavior, there is not a significant difference between

NC and SCC developed through the use of chemical admixtures, and that these elements can be appropriately designed using existing ACI and AASHTO code provisions.

After comparing test values of concrete shear strength to values predicted by design codes, the shear strengths were normalized to determine the shear strength coefficients. These values were compared to the extensive amount of previous research on shear strength of NC. The normalized coefficients ranged in value from 2.9 to 4.7. These values were consistent with the previous research on shear strength of NC. It was also observed that there was not a significant difference between coefficients for NC and SCC.

To further compare NC and SCC V_u/V_d plots were created. This plot compared the load that the beam developed at the first shear crack (V_d) to the ultimate load at failure (V_u). The result indicated that the ratio increased as the number of stirrups increased, as predicted. The V_u/V_d ratio increased from 2.1 in a beam with no stirrups to 6.4 in a beam with a 5 in. (127 mm) stirrup spacing. It was observed that a comparable increase was also seen in beams made with SCC. This result would seem to indicate that both NC and SCC benefit from an increase in the amount of shear reinforcement and, more importantly, that the SCC behaves similarly to NC in terms of shear behavior.

7. FINDINGS, CONCLUSIONS, AND RECOMMENDATIONS

7.1. INTRODUCTION

SCC has shown that it can be a very beneficial product to the construction industry; however, because it is still relatively new to the industry, there are many questions about its use. The purpose of this research was to begin to answer two of these questions. The first was how shrinkage of SCC compared to shrinkage of NC. It is known that the w/cm ratio has a significant effect on the shrinkage; so the hope was that if the w/cm ratio was held constant and a highly flowable concrete was produced by using chemical admixtures, there would not be an increase in shrinkage. The second question that was addressed was how shear strength compared between SCC and NC. Many times SCC is produced by reducing the coarse aggregate content and increasing the paste content. This approach can lead to a reduction in shear strength since coarse aggregate interlock is essential for high shear strength. This project aimed to maintain a higher coarse aggregate content and overcome the resulting loss in flowability through the addition of a higher dosage of HRWR and VMA. The shear strength of the SCC could then be compared to NC to determine if the shear strength was still acceptable.

In addition to answering these questions, testing performed was useful for the development of a SCC and for the comparison to codes used in design. It is important that the properties of SCC are known so if there is a significant difference between the properties of SCC and NC that these are taken into account in design. The tests performed were selected to determine if the design parameters used for NC could also be applied to SCC.

7.2. FINDINGS

7.2.1. Fresh Concrete Property Tests. Throughout mix design development, it was observed that concrete density and air content were not significantly different between the SCC and the NC. This was as expected result since the major constitutions of the concrete were not altered. The density of the concrete was found to be approximately 146 lb/ft^3 (2340 kg/m^3) for all concrete produced. The air content that was desired was kept higher to aid in the workability and flowability of the concrete. An air

content of 6% was selected and air entraining admixture dosages were tested and adjusted to achieve this air content.

During the mix development phase for SCC, the slump flow of the concrete was determined by performing the slump flow test. It was observed that with the concrete constitutions used, the slump flow reached its maximum amount at approximately 6 fl oz/cwt (390 mL/100 kg) of HRWR. Beyond this point, there was not a significant increase in the slump flow of the concrete even with additional HRWR. The highest dosage of the HRWR tested was still used to maintain a high slump flow after the addition of a VMA. VMA was introduced to the concrete mixture to prevent segregation. It was observed that VMA improved the concrete's stability significantly without reducing the slump flow of the concrete. By performing the slump flow test, the flowability of the concrete could be determined, but to find the passing ability of the concrete, the J-ring test was performed. It was observed that there was very little difference between SCC produced using a combination of a HRWR and VMA to that of an SCC using a HRWR alone. There was also only a small difference between the diameter of the concrete after the slump flow test and the J-ring test. This showed that the concrete had a high passing ability since there was little difference between restrained and unrestrained flow, but also that the VMA did not significantly alter the passing ability of the concrete.

To show that the SCC had an improved stability as a result of the addition of the VMA, the static segregation of the SCC was determined. This was determined by the static segregation test. It was observed that the static segregation was highest with concrete produced using the HRWR alone. This was as expected since there was little to prevent the aggregate from settling within the concrete mixture. After the addition of the VMA, the segregation of the concrete began to decrease. At first, the low dosage of 4 fl oz/cwt (260 mL/100 kg) of VMA showed little improvement over the HRWR alone; however, a dosage of 8 fl oz/cwt (520 mL/kg) showed significant improvement. The higher dosage of VMA was selected to ensure that there was as little segregation as possible.

7.2.2. Hardened Concrete Property Tests. After the mix design had been developed based on achieving acceptable fresh properties for the SCC, the hardened

properties were tested to determine if the concrete would still be acceptable.

Compression strength testing showed that as the amount of fly ash was increased, there was a decrease in early age strength but an increase in later age strength. A 30% replacement of portland cement with fly ash was selected to afford the benefits of increased slump flow in the fresh state while still maintaining the higher early age strength of a 100% portland cement concrete. The MOR was determined by testing a beam and normalized by dividing this value by the square root of the compressive strength of that particular concrete. This compressive strength was determined by testing a cylinder cast from the same batch of concrete. It was determined that there was not a significant difference between the MOR of SCC and FA concrete. SCC was also shown to be slightly higher than NC. Overall, this provided evidence that the addition of HRWR and VMA had little effect on the concrete's MOR.

7.2.3. Shrinkage Testing. Shrinkage testing was another opportunity to compare SCC and NC. The purpose of this testing was to determine what affect, if any, the chemical admixtures would have on shrinkage. In addition to these two types of concrete, an intermediate concrete made with a 30% replacement of fly ash and no chemical admixtures was tested. After shrinkage data was recorded and plots were made to show shrinkage strain over time, the data was compared to predictions based on three shrinkage prediction models. These models were ACI 209R, Bazant-Baweja B3, and GL2000. By examining plots of shrinkage as a function of time, it was observed that the FA concrete had the most shrinkage and was followed closely by SCC, while the NC had the smallest shrinkage. This would seem to indicate that the fly ash contributed to the slight increase in shrinkage observed as opposed to the chemical admixtures. To determine if this increase in shrinkage was significant, standard deviation bars were added to select points. It was observed that many of the standard deviation bars overlapped, indicating there was not a significant statistical difference in the shrinkage between the three concrete types.

After comparing the different types of concrete to each other, the shrinkage values determined in the lab were compared to values predicted by the shrinkage models. It was observed that the ACI 209R Model most accurately represented the shrinkage observed during testing for all three concrete mixes. The initial predicted shrinkage was higher

than what was observed in the lab and the ultimate predicted shrinkage was lower than data taken in the lab. Both the Bazant-Baweja B3 and the GL2000 models under-predicted the shrinkage for all three concrete types. Of the two, the Bazant-Baweja B3 was the closest to the plotted data; however, it was consistently lower throughout the time testing was conducted.

7.2.4. Full-Scale Beam Shear Tests. To address the concern of shear strength of SCC, full-scale shear tests were performed on NC and SCC beams. The shear strength was determined through testing and compared to the predicted values for V and V_c using the ACI and AASHTO codes. It was determined that there was not a significant difference between predicted values and values determined through testing. It was noted that ACI Equation 11-3 and AASHTO were conservative in their predictions of shear strength; however ACI Equation 11-5 was not always conservative. This was likely a result of the high amount of longitudinal steel reinforcement within the beams. It was noted that ACI Equation 11-5 was not conservative in its prediction of shear strength for either the NC or SCC.

The last thing to be considered was the shear strength contributed by the concrete. Based on the test results, there was not a significant difference in strength when comparing NC and SCC. Shear strengths determined through testing were not significantly different between NC or SCC beams made with the same shear reinforcement. This result would seem to indicate that as far as shear behavior, there is not a significant difference between NC and SCC developed through the use of chemical admixtures, and that these elements can be appropriately designed using existing ACI and AASHTO code provisions.

When comparing beams made with SCC to beams made with NC, the SCC beams had a higher shear strength; however, there was also a much greater compressive strength. After predicted and tested shear strength values had been compared, the shear strengths were normalized in order to determine the shear strength coefficients. This was done by dividing the shear strength of the concrete by the product of beam width, effective beam depth, and the square root of the concrete compressive strength. The normalized coefficients ranged in value from 2.9 to 4.7. These values were compared to normalized concrete shear strength values collected by Tureyen and Frosch (2003) on

concrete shear strength as a function of the longitudinal reinforcement ratio. For the reinforcement ratio used in this research, the values for the normalized concrete shear strength were consistent with the previous research on shear strength of NC.

Plots of V_u/V_d showed that as the number of stirrups increased so did the ratio, as predicted. The V_u/V_d ratio increased from 2.1 in a beam with no stirrups to 6.4 in a beam with a 5 in. (127 mm) stirrup spacing. It was also noticed that the increase was only slightly smaller in beams made with SCC. This result seems to indicate that both NC and SCC benefit greatly from an increase in the amount shear reinforcement but, more importantly, that SCC behaves similarly to NC in terms of shear behavior.

7.3. CONCLUSIONS

Based on the previously stated findings, the following conclusions can be drawn in reference to the evaluation and prediction of the performance of the chemically-based SCC developed for the purpose of this research:

1. There was not a significant difference between NC and SCC with regard to density or air content.
2. SCC showed a significant increase in slump flow with the addition of a HRWR.
3. SCC showed an improved stability with the addition of a VMA, and that static segregation was highest in concrete made with a HRWR alone.
4. Long term compressive strengths were similar for both NC and SCC; however, it was observed that the concrete made with fly ash had a longer hydration period.
5. There was not a significant difference between NC and SCC with regard to MOR.
6. By comparing shrinkage plots, fly ash contributed to a slight increase in shrinkage; however, this increase was not statistically significant.
7. There was not a significant difference in shrinkage between NC and SCC.
8. The ACI 209R Model provided the most accurate shrinkage prediction model when compared to test values.

9. ACI Equation 11-3 and AASHTO were conservative in their prediction of shear strength for NC and SCC; however, ACI Equation 11-5 was not always conservative.
10. Normalized shear strength coefficients ranged from 2.9 to 4.7 and were consistent with the extensive amount of previous research conducted on NC.
11. V_u/V_d values indicated there was an increase in ductility with the addition of shear reinforcement and that both NC and SCC benefited equally from this additional shear reinforcement.

7.4. RECOMMENDATIONS

Based on the findings and conclusions stated in the previous sections, the following recommendations were derived in regard to the use of SCC concrete:

1. Shrinkage models for conventional concretes are applicable to the SCC studied.
2. When using the SCC concrete mixes studied, ACI and AASHTO design provisions may be used to conservatively determine the shear strength.
3. SCC can be produced to provide the benefits of increased flow and passing abilities while still maintaining shear strength and resulting in comparable shrinkage with NC.
4. Additional testing is required to study the effects of prestressing on SCC.

APPENDIX A.
MATERIAL DATA SHEETS
(Reproduced with permission from BASF)



3 4	03 30 00	Product Data Cast-In-Place Concrete Precast Concrete Mass Concrete Masonry Grouting
	03 40 00	
	03 70 00	
	04 05 16	

Description

GLENIUM® 7500 full-range water-reducing admixture is based on the next generation of polycarboxylate technology found in all of the GLENIUM 7000 series products. This technology combines state-of-the-art molecular engineering with a precise understanding of regional cements to provide specific and exceptional value to all phases of the concrete construction process.

GLENIUM 7500 admixture is very effective in producing concrete mixtures with different levels of workability including applications that require self-consolidating concrete (SCC). The use of GLENIUM 7500 admixture results in faster setting characteristics as well as improved early age compressive strength. GLENIUM 7500 admixture meets ASTM C 494/C 494M compliance requirements for Type A, water-reducing, and Type F, high-range water-reducing, admixtures.

Applications

Recommended for use in:

- Concrete with varying water reduction requirements (5-40%)
- Concrete where control of workability and setting time is critical
- Concrete where high flowability, increased stability, high early and ultimate strengths, and improved durability are needed
- Production of Rheodynamic® Self-Consolidating Concrete (SCC) mixtures
- 4x4™ Concrete for fast-track construction
- Pervious Concrete mixtures

GLENIUM® 7500

Full-Range Water-Reducing Admixture

Features

- Dosage flexibility for normal, mid-range and high-range applications
- Excellent early strength development
- Controls setting characteristics
- Optimizes slump retention/setting relationship
- Consistent air entrainment

Benefits

- Faster turnover of forms due to accelerated early strength development
- Reduces finishing labor costs due to optimized set times
- Use in fast track construction
- Minimizes the need for slump adjustments at the jobsite
- Less jobsite QC support required
- Fewer rejected loads
- Optimizes concrete mixture costs

Performance Characteristics

Concrete produced with GLENIUM 7500 admixture achieves significantly higher early age strength than first generation polycarboxylate high-range water-reducing admixtures. GLENIUM 7500 admixture also strikes the perfect balance between workability retention and setting characteristics in order to provide efficiency in placing and finishing concrete. The dosage flexibility of GLENIUM 7500 allows it to be used as a normal, mid-range, and high-range water reducer.

Guidelines for Use

Dosage: GLENIUM 7500 admixture has a recommended dosage range of 2-15 fl oz/cwt (130-975 mL/100 kg) of cementitious materials. For most mid to high-range applications, dosages in the range of 5-8 fl oz/cwt (325-520 mL/100 kg) will provide excellent performance. For high performance and Rheodynamic Self-Consolidating Concrete mixtures, dosages of up to 12 fl oz/cwt (780 mL/100 kg) of cementitious materials can be utilized. Because of variations in concrete materials, jobsite conditions and/or applications, dosages outside of the recommended range may be required. In such cases, contact your local BASF Construction Chemicals representative.

Mixing: GLENIUM 7500 admixture can be added with the initial batch water or as a delayed addition. However, optimum water reduction is generally obtained with a delayed addition.

**Master
Builders**

Product Data: GLENIUM® 7500

Product Notes

Corrosivity – Non-Chloride, Non-Corrosive: GLENIUM 7500 admixture will neither initiate nor promote corrosion of reinforcing steel embedded in concrete, prestressing steel or of galvanized steel floor and roof systems. Neither calcium chloride nor other chloride-based ingredients are used in the manufacture of GLENIUM 7500 admixture.

Compatibility: GLENIUM 7500 admixture is compatible with most admixtures used in the production of quality concrete, including normal, mid-range and high-range water-reducing admixtures, air-entrainers, accelerators, retarders, extended set control admixtures, corrosion inhibitors, and shrinkage reducers.

Do not use GLENIUM 7500 admixture with admixtures containing beta-naphthalene sulfonate. Erratic behaviors in slump, workability retention and pumpability may be experienced.

Storage and Handling

Storage Temperature: GLENIUM 7500 admixture must be stored at temperatures above 40 °F (5 °C). If GLENIUM 7500 admixture freezes, thaw and reconstitute by mechanical agitation.

Shelf Life: GLENIUM 7500 admixture has a minimum shelf life of 9 months. Depending on storage conditions, the shelf life may be greater than stated. Please contact your local sales representative regarding suitability for use and dosage recommendations if the shelf life of GLENIUM 7500 admixture has been exceeded.

Packaging

GLENIUM 7500 admixture is supplied in 55 gal (208 L) drums, 275 gal (1040 L) totes and by bulk delivery.

Related Documents

Material Safety Data Sheets: GLENIUM 7500 admixture.

Additional Information

For additional information on GLENIUM 7500 admixture or on its use in developing concrete mixtures with special performance characteristics, contact your BASF Construction Chemicals representative.

The Admixture Systems business of BASF Construction Chemicals is a leading provider of innovative admixtures for specialty concrete used in the ready mix, precast, manufactured concrete products, underground construction and paving markets throughout the North American region. The Company's respected Master Builders brand products are used to improve the placing, pumping, finishing, appearance and performance characteristics of concrete.

LIMITED WARRANTY NOTICE. We warrant our products to be of good quality and will replace or, at our discretion, refund the purchase price of any products proved defective. Satisfactory results depend not only upon quality products, but also upon many factors beyond our control. Therefore, except for such replacement or refund, BASF MAKES NO WARRANTY OR GUARANTEE, EXPRESS OR IMPLIED, INCLUDING WARRANTIES OF FITNESS FOR A PARTICULAR PURPOSE OR MERCHANTABILITY, RESPECTING ITS PRODUCTS, and BASF shall have no other liability with respect thereto. Any claims regarding product defect must be received in writing within one (1) year from the date of shipment. User shall determine the suitability of the products for the intended use and assume all risks and liability in connection therewith. Any authorized change in the printed recommendations concerning the use of our products must bear the signature of the BASF Technical Manager.

This information and all further technical advice are based on BASF's present knowledge and experience. However, BASF assumes no liability for providing such information and advice including the extent to which such information and advice may relate to existing third party intellectual property rights, especially patent rights. BASF SHALL NOT BE RESPONSIBLE FOR CONSEQUENTIAL, INDIRECT OR INCIDENTAL DAMAGES (INCLUDING LOSS OF PROFITS) OF ANY KIND. BASF reserves the right to make any changes according to technological progress or further developments.

For Professional use only. Not for sale to or use by the general public.

BASF Construction Chemicals
Admixture Systems

www.masterbuilders.com

United States 23700 Chagrin Boulevard, Cleveland, Ohio 44122-5544 • Tel: 800 628-9990 • Fax: 216 839-8821
Canada 1800 Clark Boulevard, Brampton, Ontario L6T 4M7 • Tel: 800 387-5882 • Fax: 905 792-0651

© Construction Research & Technology GmbH

© BASF Construction Chemicals, 2009 • Printed in USA • 12/09 • LIT # 2000025



**Master
Builders**



3	03 30 00	Product Data Cast-in-Place Concrete Precast Concrete Mass Concrete
	03 40 00	
	03 70 00	

Description

Micro Air air-entraining admixture provides concrete with extra protection by creating air bubbles that are ultrastable, small and closely spaced – a characteristic especially useful in the types of concrete known for their difficulty to entrain and maintain the air content desired.

Even when used at a lower dosage than standard air-entraining admixtures, Micro Air admixture meets the requirements of ASTM C 260, AASHTO M 154, and CRD-C 13.

Applications

Recommended for use in:

- Concrete exposed to cyclic freezing and thawing
- Production of high-quality normal or lightweight concrete (heavyweight concrete normally does not contain entrained air)

MICRO AIR®

Air-Entraining Admixture

Features

- Ready-to-use in the proper concentration for rapid, accurate dispensing
- Greatly improved stability of air-entrainment
- Ultra stable air bubbles

Benefits

- Increased resistance to damage from cyclic freezing and thawing
- Increased resistance to scaling from deicing salts
- Improved plasticity and workability
- Improved air-void system in hardened concrete
- Improved ability to entrain and retain air in low-slump concrete, concrete containing high-carbon content fly ash, concrete using large amounts of fine materials, concrete using high-alkali cements, high-temperature concrete, and concrete with extended mixing times
- Reduced permeability – increased watertightness
- Reduced segregation and bleeding

Performance Characteristics

Concrete durability research has established that the best protection for concrete from the adverse effects of freezing and thawing cycles and deicing salts results from: proper air content in the hardened concrete, a suitable air-void system in terms of bubble size and spacing and adequate concrete strength, assuming the use of sound aggregates and proper mixing, transporting, placing, consolidation, finishing and curing techniques. Micro Air admixture can be used to obtain adequate freezing and thawing durability in a properly proportioned concrete mixture, if standard industry practices are followed.

Air Content Determination: The total air content of normal weight concrete should be measured in strict accordance with ASTM C 231, "Standard Test Method for Air Content of Freshly Mixed Concrete by the Pressure Method" or ASTM C 173/C 173M, "Standard Test Method for Air Content of Freshly Mixed Concrete by the Volumetric Method."

The air content of lightweight concrete should only be determined using the Volumetric Method. The air content should be verified by calculating the gravimetric air content in accordance with ASTM C 138/C 138M, "Standard Test Method for Density (Unit Weight), Yield, and Air Content (Gravimetric) of Concrete." If the total air content, as measured by the Pressure Method or Volumetric Method and as verified by the Gravimetric Method, deviates by more than 1-1/2%, the cause should be determined and corrected through equipment calibration or by whatever process is deemed necessary.

**Master
Builders**

Product Data: MICRO AIR®

Guidelines for Use

Dosage: There is no standard dosage for Micro Air admixture. The exact quantity of air-entraining admixture needed for a given air content of concrete varies because of differences in concrete making materials and ambient conditions. Typical factors that might influence the amount of air entrained include: temperature, cementitious materials, sand gradation, sand-aggregate ratio, mixture proportions, slump, means of conveying and placement, consolidation and finishing technique.

The amount of Micro Air admixture used will depend upon the amount of entrained air required under actual job conditions. In a trial mixture, use 1/8 to 1-1/2 fl oz/cwt (8-98 mL/100 kg) of cement. In mixtures containing water-reducing or set-control admixtures, the amount of Micro Air admixture needed is somewhat less than the amount required in plain concrete. Due to possible changes in the factors that can affect the dosage of Micro Air admixture, frequent air content checks should be made during the course of the work. Adjustments to the dosage should be based on the amount of entrained air required in the mixture at the point of placement. If an unusually high or low dosage of Micro Air admixture is required to obtain the desired air content, consult your BASF Construction Chemicals representative. In such cases, it may be necessary to determine that, in addition to a proper air content in the fresh concrete, a suitable air-void system is achieved in the hardened concrete.

Dispensing and Mixing: Add Micro Air admixture to the concrete mixture using a dispenser designed for air-entraining admixtures; or add manually using a suitable measuring device that ensures accuracy within plus or minus 3% of the required amount. For optimum, consistent performance, the air-entraining admixture should be dispensed on damp, fine aggregate or with the initial batch water. If the concrete mixture contains lightweight aggregate, field evaluations should be conducted to determine the best method to dispense the air-entraining admixture.

Precaution

In a 2005 publication from the Portland Cement Association (PCA R&D Serial No. 2789), it was reported that problematic air-void clustering that can potentially lead to above normal decreases in strength was found to coincide with late additions of water to air-entrained concretes. Late additions of water include the conventional practice of holding back water during batching for addition at the jobsite. Therefore, caution should be exercised with delayed additions to air-entrained concrete. Furthermore, an air content check should be performed after any post-batching addition to an air-entrained concrete mixture.

Product Notes

Corrosivity – Non-Chloride, Non-Corrosive: Micro Air admixture will neither initiate nor promote corrosion of reinforcing and prestressing steel embedded in concrete, or of galvanized steel floor and roof systems. No calcium chloride or other chloride-based ingredients are used in the manufacture of this admixture.

Compatibility: Micro Air admixture may be used in combination with any BASF Construction Chemicals admixture, unless stated otherwise on the data sheet for the other product. When used in conjunction with other admixtures, each admixture must be dispensed separately into the mixture.

Storage and Handling

Storage Temperature: Micro Air admixture should be stored and dispensed at 35 °F (2 °C) or higher. Although freezing does not harm this product, precautions should be taken to protect it from freezing. If it freezes, thaw and reconstitute by mild mechanical agitation. **Do not use pressurized air for agitation.**

Shelf Life: Micro Air admixture has a minimum shelf life of 18 months. Depending on storage conditions, the shelf life may be greater than stated. Please contact your BASF Construction Chemicals representative regarding suitability for use and dosage recommendations if the shelf life of Micro Air admixture has been exceeded.

Safety: Micro Air admixture is a caustic solution. Chemical goggles and gloves are recommended when transferring or handling this material. (See MSDS and/or product label for complete information.)

Packaging

Micro Air admixture is supplied in 55 gal (208 L) drums, 275 gal (1040 L) totes and by bulk delivery.

Related Documents

Material Safety Data Sheets: Micro Air admixture.

Additional Information

For suggested specification information or for additional product data on Micro Air admixture, contact your BASF Construction Chemicals representative.

The Admixture Systems business of BASF Construction Chemicals is a leading provider of innovative admixtures for specialty concrete used in the ready mix, precast, manufactured concrete products, underground construction and paving markets throughout the North American region. The Company's respected Master Builders brand products are used to improve the placing, pumping, finishing, appearance and performance characteristics of concrete.



BASF Construction Chemicals, LLC
Admixture Systems

www.masterbuilders.com

United States 23700 Chagrin Boulevard, Cleveland, Ohio 44122-5544 • Tel: 800 628-9990 • Fax: 216 839-8821

Canada 1800 Clark Boulevard, Brampton, Ontario L6T 4M7 • Tel: 800 387-5862 • Fax: 905 792-0851

© Construction Research & Technology GMBH

© BASF Construction Chemicals, LLC 2007 • Printed in USA • 10/08 • LIT # 1017034

**Master
Builders**



The Chemical Company

RHEOMAC[®] VMA 362

Viscosity modifying admixture

DESCRIPTION

Rheomac VMA 362 viscosity modifying admixture (VMA) is a ready-to-use, liquid admixture that is specially developed for producing concrete with enhanced viscosity and controlled rheological properties.

Concrete with **Rheomac VMA 362** admixture exhibits superior stability, increasing resistance to segregation and facilitating placement and consolidation. **Rheomac VMA 362** meets AS 1478 for Type SN admixtures.

RECOMMENDED FOR

- Concrete containing "gap-graded" aggregates
- Lean concrete mixtures
- Concrete containing manufactured sand
- Concrete as a pumping aid
- Concrete as a finishing aid
- Concrete mixtures requiring "more body"
- Rheodynamic® Self-Consolidating Concrete (SCC) or Super Workable Concrete (SWC)
- Liquid Sand™

FEATURES AND BENEFITS

- *Modifies viscosity of concrete*
- *Easy to dispense*
- *Controls bleeding*
- *Modifies rheological properties*
- *Provides flexibility in mixture proportioning and batching*
- *Provides concrete stability during transport and placement*
- *Reduces segregation, even with highly-fluid concrete mixtures*
- *Enhances pumping and finishing*
- *Enhances surface appearance*
- *Provides superior and predictable in-place concrete properties*
- *Facilitates production of highly-fluid mixtures such as Rheodynamic® Self-Consolidating Concrete (SCC) or Super Workable Concrete (SWC)*

PERFORMANCE CHARACTERISTICS

Setting Time

Rheomac VMA 362 admixture has little to no impact on concrete setting time within the recommended dosage range of 150-900 mL/100 kg of cementitious material.

Compressive Strength

Rheomac VMA 362 admixture does not affect the compressive strength of concrete.

Viscosity

Rheomac VMA 362 admixture will exhibit an increase in concrete viscosity with increasing dosage of the admixture.

This desirable characteristic facilitates concrete placement, consolidation and finishing and provides stability to very fluid concrete mixes.

Workability

Rheomac VMA 362 admixture enhances workability.

Air Content

Rheomac VMA 362 admixture does not affect the air content in either air-entrained or non air-entrained concrete.

Typical dosages of air-entraining admixtures may be used to achieve the desired air content.

DOSAGE

The recommended dosage range for **Rheomac VMA 362** admixture is 150-900 mL/100 kg of cementitious materials.

A dosage of 150-400 mL/100 kg is recommended for typical concrete mixtures requiring "more body" to facilitate pumping and finishing procedures.

A dosage of up to 900 mL/100 kg is recommended to provide stability in super workable (self-consolidating) concrete mixtures.

Because of variations in concrete materials, jobsite conditions and/or applications dosages outside of the recommended range may be required.

MIXING

Rheomac VMA 362 admixture is typically added with the initial mix water.

Alternatively, **Rheomac VMA 362** admixture may be added after all other concreting ingredients have been batched and thoroughly mixed, either at the batch plant or at the jobsite.

COMPATIBILITY

Rheomac VMA 362 admixture is compatible with most other admixtures used in the production of quality concrete including normal, mid-range and high-range water-reducing admixtures, and air-entraining admixtures.

Rheomac VMA 362 admixture is also compatible with typical accelerators, retarders, extended set-control admixtures, corrosion inhibitors and shrinkage reducing admixtures. However a field trial is recommended to ensure appropriate performance.

STORAGE

Rheomac VMA 362 admixture must be stored at temperatures above 0°C and below 54°C.

Protect **Rheomac VMA 362** admixture from freezing as it cannot be reconstituted after thawing.

SHELF LIFE

A product stability evaluation has shown that **Rheomac VMA 362** admixture has a shelf life of 8 months.

Please contact your local BASF Construction Chemicals Technical Representative regarding suitability for use and dosage recommendations if the stated minimum shelf life of **Rheomac VMA 362** admixture has been exceeded.



The Chemical Company

RHEOMAC[®] VMA 362

DISPENSING

Rheomac VMA 362 admixture should be dispensed using direct-feed dispensing systems

It is recommended that fail-safe features must be included in this dispenser application for potential meter malfunctions

PACKAGING

Rheomac VMA 362 is available in 20L Cubes, 205L Drums and 1000L Pallecons.

All BASF Construction Chemicals Australia & New Zealand data sheets are updated on a regular basis, it is the user's responsibility to obtain the most recent issue **ARmacVMA362/2/0707**

STATEMENT OF RESPONSIBILITY

The technical information and application advice given in this BASF Construction Chemicals publication are based on the present state of our best scientific and practical knowledge. As the information herein is of a general nature, no assumption can be made as to a product's suitability for a particular use or application and no warranty as to its accuracy, reliability or completeness either expressed or implied is given other than those required by law. The user is responsible for checking the suitability of products for their intended use.

NOTE

Field service where provided does not constitute supervisory responsibility. Suggestions made by BASF Construction Chemicals either orally or in writing may be followed, modified or rejected by the owner. engineer or contractor since they, and not BASF Construction Chemicals, are responsible for carrying out procedures appropriate to a specific application.

BASF Construction Chemicals Australia Pty Ltd
Incorporated in NSW A.B.N. 46 000 450 288
Head Office: 11 Stanton Road Seven Hills, NSW 2147
Ph: (02) 8811 4200

Newcastle	(02) 4961 3819	Adelaide	(08) 8139 7500
Canberra	(02) 6280 6010	Perth	(08) 9386 2600
Brisbane	(07) 3633 9900	Darwin	(08) 8984 3269
Townsville	(07) 4774 7344	Kalgoorlie	0417 772 355
Melbourne	(03) 9549 0300		

BASF Construction Chemicals New Zealand Ltd
BASF WEB SITES www.basf-cc.com.au

Head Office: 45 William Pickering Drive, Albany, Auckland Ph (09) 414 7233
www.basf-cc.co.nz www.basf-ucc.com

APPENDIX B.
SHRINKAGE PLOTS

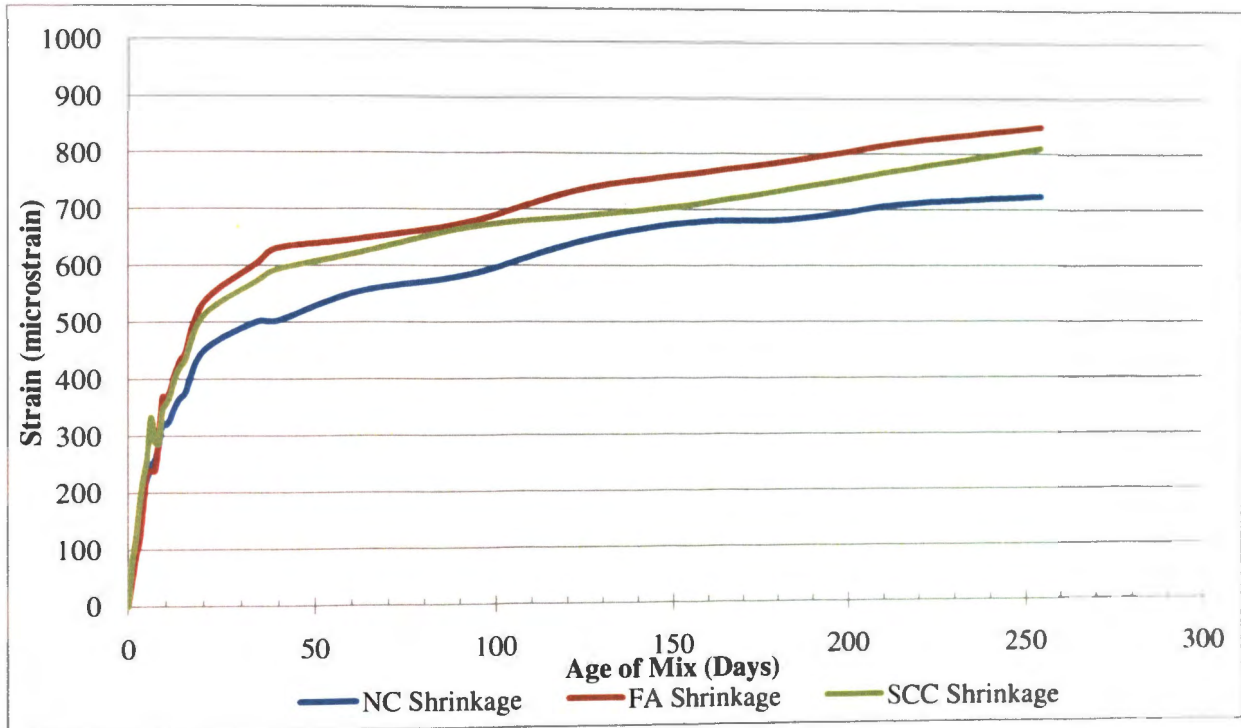

Figure B.1. Concrete Shrinkage

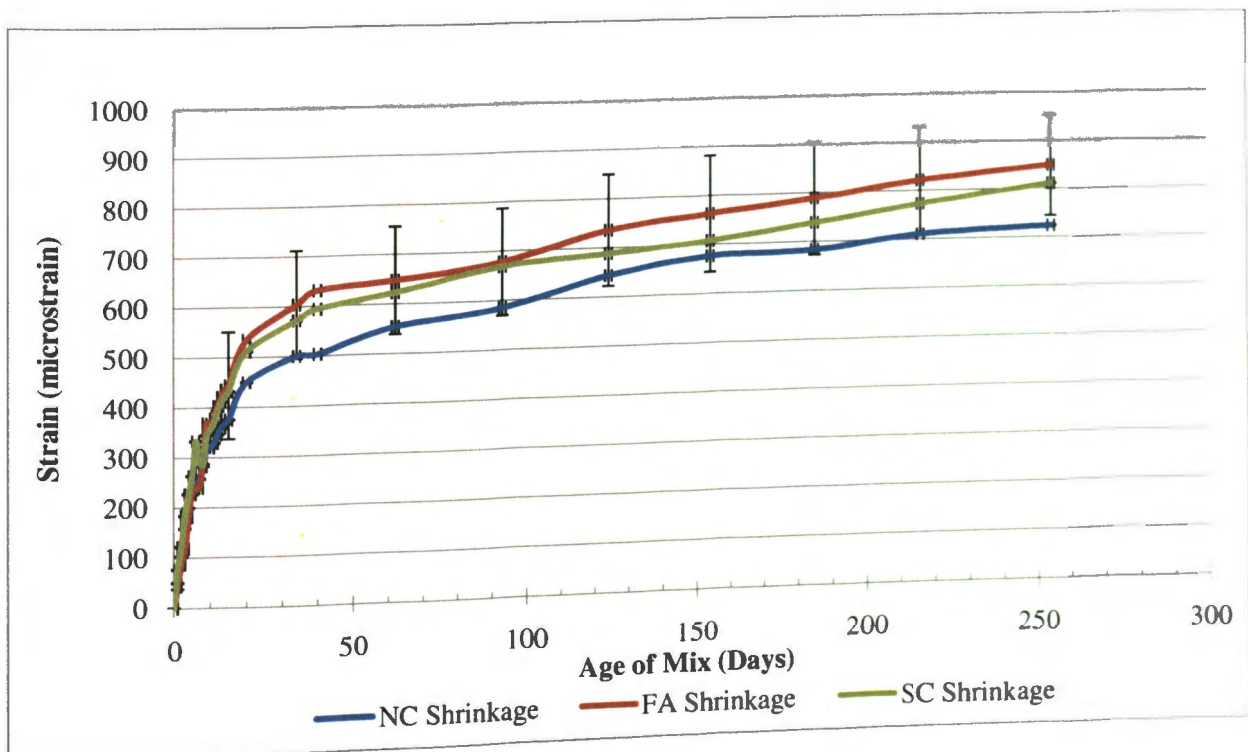

Figure B.2. Concrete Shrinkage

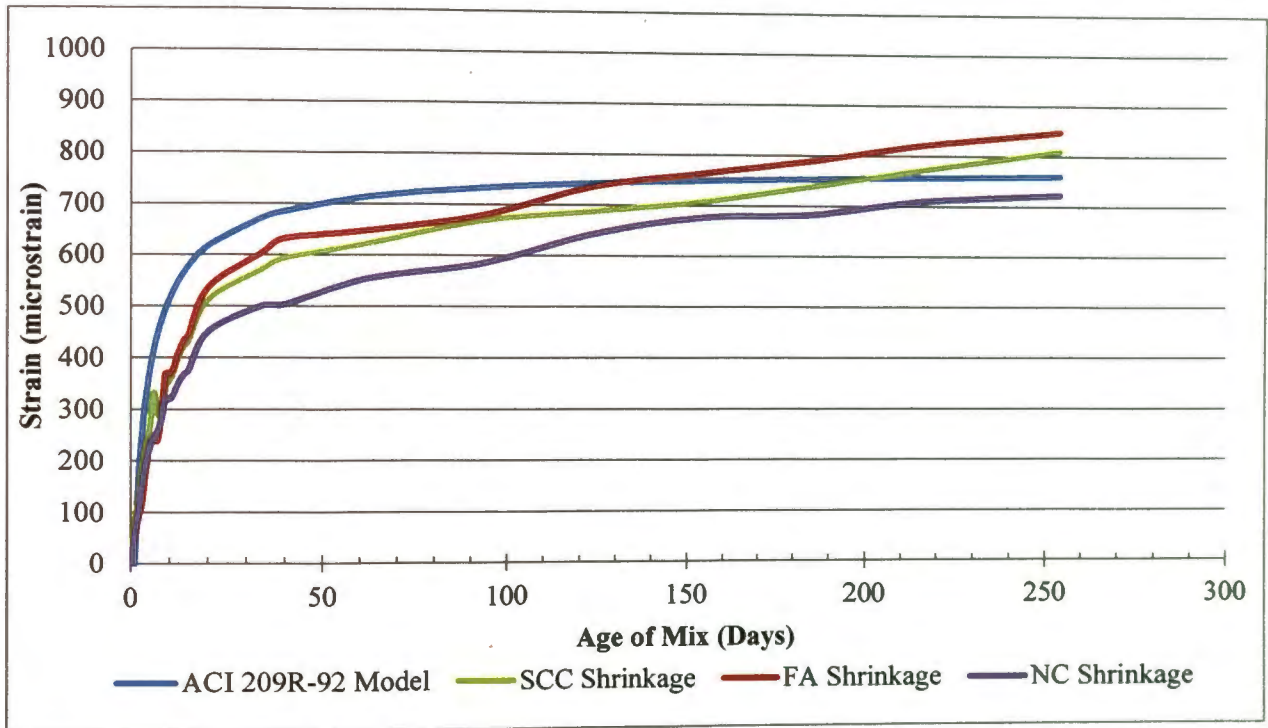

Figure B.3. Concrete Shrinkage Compared to ACI 209R-92 Model

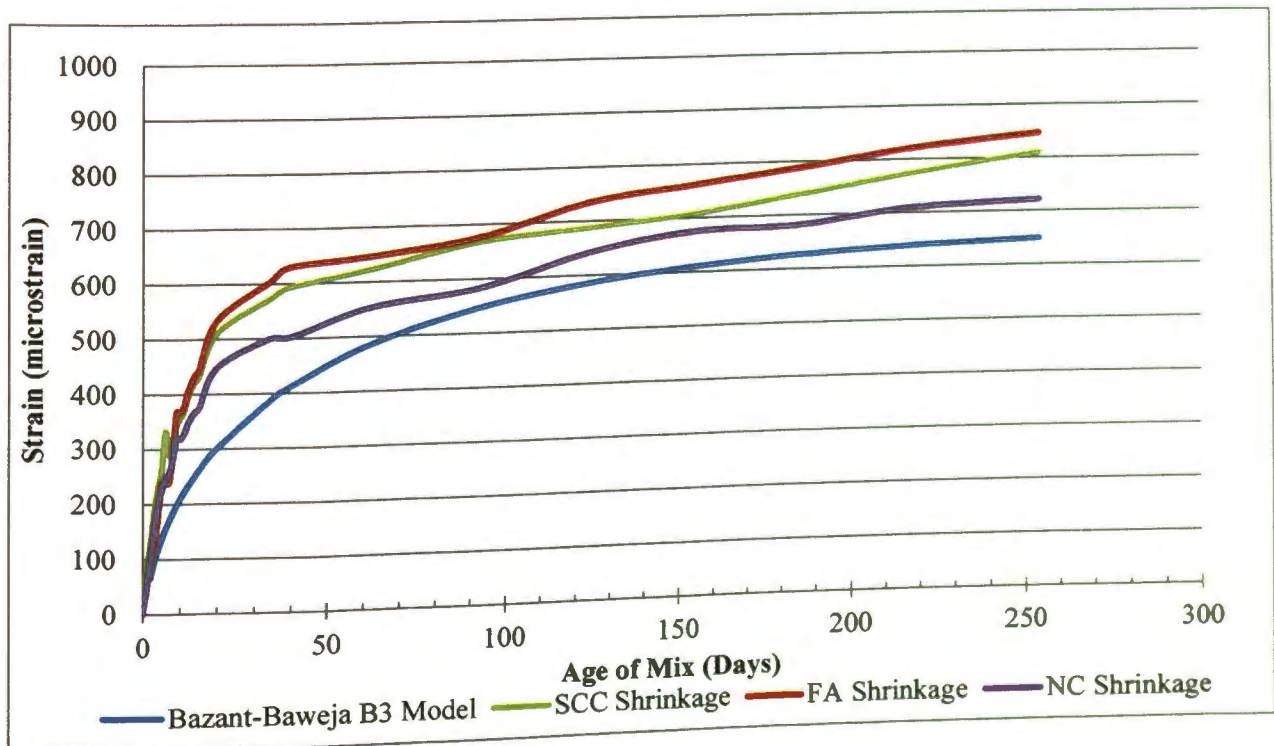

Figure B.4. Concrete Shrinkage Compared to Bazant-Baweja B3 Model

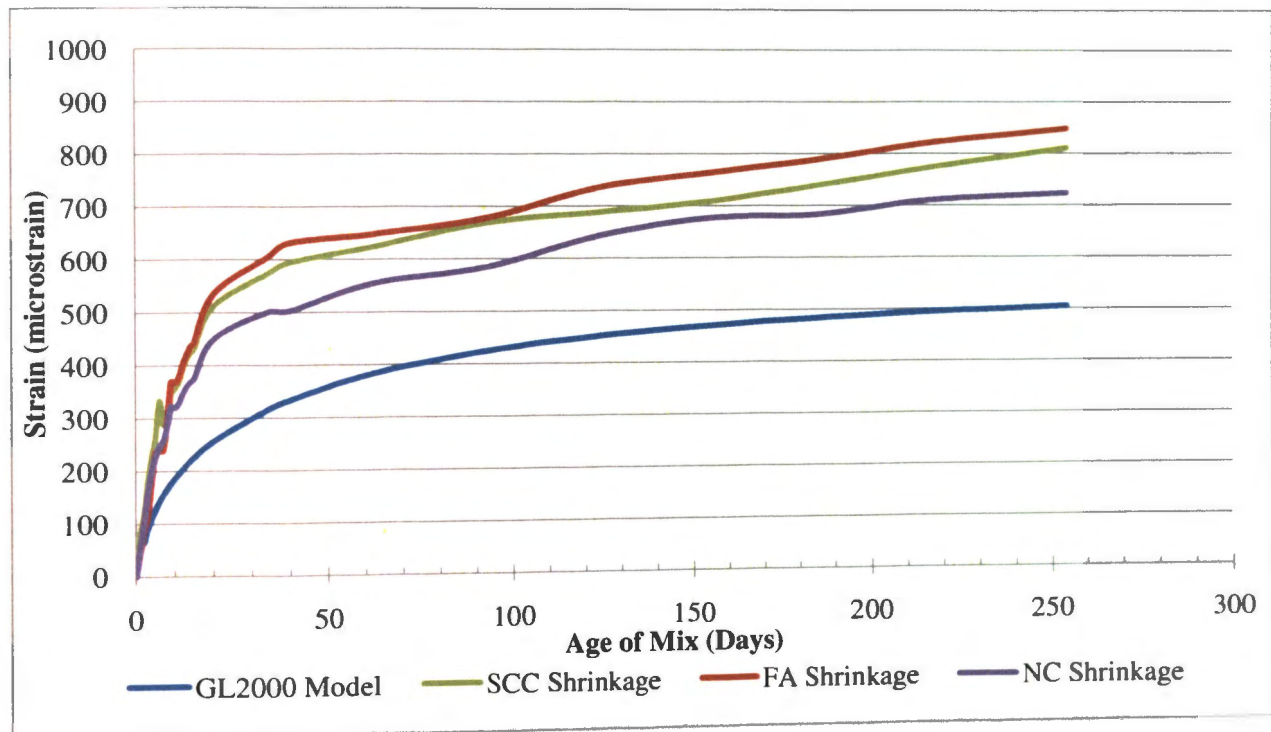

Figure B.5. Concrete Shrinkage Compared to GL2000 Model

BIBLIOGRAPHY

- ACI Committee 440, Guide for the Design and Construction of Concrete Reinforced with FRP Bars (440.1R-01), American Concrete Institute, Farmington Hills, Michigan, 2001, 41 pp.
- American Association of State and Highway Transportation Officials (2007); AASHTO LRFD Bridge Design Specification;" American Association of State and Highway Transportation Officials; Washington DC.
- American Association of State and Highway Transportation Officials (1998); "Standard Specification for Highway Gridges;" 16th Edition; American Association of State Highway and Transportation Officials; Washington DC.
- American Concrete Institute (ACI 209.2R-08) (2008); "Guide for Modeling and Calculating Shrinkage and Creep in Hardened Concrete" American Concrete Institute; Farmington Hills, Michigan.
- American Concrete Institute (ACI 211.1-91) (1991); "Standard Practice for Selecting Proportions for Normal, Heavyweight, and Mass Concrete" American Concrete Institute; Farmington Hills, Michigan.
- American Concrete Institute (ACI 22.4R-04) (2004); "Guide for the Use of High-Range Water-Reducing Admixtures (Superplasticizers) in Concrete" American Concrete Institute; Farmington Hills, Michigan.
- American Concrete Institute (ACI 237R-07) (2007); "Self-Consolidating Concrete;" American Concrete Institute; Farmington Hills, Michigan.
- ASTM C 1610/C 1610M – 06a; "Standard Test Method for Static Segregation of Self-Consolidating Concrete Using Column Technique;" American Society for Testing and Materials; West Conshohocken, Pennsylvania.
- ASTM C 1621/C 1621M – 09I; "Standard Tst Method for passing Ability of Self-Consolidating Concrete by J-Ring;" American Society for Testing and Materials; West Conshohocken, Pennsylvania.
- ASTM C 31/C31M-09 (2009) "Standard Practice for Making and Curing Concrete Test Specimens in the Field;" American Society for Testing and Materials; West Conshohocken, Pennsylvania.
- ASTM C 39/C 39 M – 10 (2010); "Standard Test Method for Compressive Strength of Cylindrical Concrete Specimens;" American Society for testing and Materials; West Conshohocken, Pennsylvania.

- ASTM C 490/C 490M – 08 (2008); “Standard Practice for Use of Apparatus for the Determination of Length Change of Hardened Cement Paste, Mortar, and Concrete;” American Society for Testing and Materials; West Conshohocken, Pennsylvania.
- ASTM C157/C 157M – 08 (2008); “Test method for Length change of hardened Hydraulic-Cement Mortar and Concrete;” American Society for Testing and Materials; West Conshohocken, Pennsylvania.
- ASTM C1611/ C 1611M – 05 (2005); “Standard Test Method for Slump flow of Self-Consolidating Concrete;” American Society for Testing and Materials; West Conshohocken, Pennsylvania.
- ASTM C78 – 10 (2010); “Standard Test Method for Flexural Strength of Concrete (Using Simple Beam with Third-Point Loading);” American Society for Testing and Materials; West Conshohocken, Pennsylvania.
- ASTM E8/E8M – 09 (2009); “Standard Test Methods for Tension Testing of Metallic Materials;” American Society for Testing and Materials; West Conshohocken, Pennsylvania.
- Boresi, Arthur P., and Richard J. Schmidt. *Advanced Mechanics of Materials*. Hoboken, New Jersey: John Wiley & Sons, inc., 2003.
- Canny J, A Computational Approach to Edge Detection. *IEEE Transactions PAMI* 1986. Vol 10, pp. 679-698.
- El-Chabib, Hassan, and Moncef Nehdi. (2006); “Effect of Mixture Design Parameters on Segregation of Self-Consolidating Concrete” *ACI Materials Journal*; Vol. 103, pp. 374-383.
- Gesoglu, Mehmet, Erhan Guneyisi, and Erdogan Ozbay. “Properties of Self-Compacting Concretes Made With Binary, Ternary, and Quaternary Cementitious Blends of Fly Ash, Blast Furnace Slag, and Silica Fume” *Construction and Building Materials*. Science Direct. pp. 8.
- Ghafoori, Nader, and Hamidou Diawara. “Influence of Temperature on Fresh Performance of Self-Consolidating Concrete: Construction and Building Materials. Science Direct. pp. 10.
- Hassan, A.A.A., K.M.A. Hossain, and M. Lachemi. “Behavior of Full-Scale Self-Consolidating Concrete Beams in Shear” *Cement & Concrete Composites*. Science Direct. pp. 9. <www.elsevier.com/locate/cemconcomp>.

- Hassan, A.A.A., K.M.A. Hossain, and M. Lachemi. "Strength, Cracking and Deflection Performance of Large-Scale Self-Consolidating Concrete Beams Subjected to Shear Failure" *Engineering Structures*. Science Direct. pp. 10.
www.elsevier.com/locate/engstruct.
- Hawkins, N.M., Kuchma, D.A., Mast, R.F., Marsh, M.L., and Reineck, K.H., *NCHRP Report 549: Simplified Shear Design of Structural Concrete Members*, Transportation Research Board of the National Academies, Washington, D.C., 2005.
- Hwang, Soo-Duck; Khayat, Kamal H. (2010); "Effect of Mix Design on Restrained Shrinkage of Self-Consolidating Concrete;" *Materials and Structures Journal*; Sherbrooke, Canada.
- Khayat, K.H. (1999); "Workability, Testing and Performance of Self-Consolidating Concrete;" *ACI Materials Journal*; Vol. 96, pp. 346-353.
- Khayat, K.H. (2000); "Optimization and Performance of Air-Entrained, Self-Consolidating Concrete;" *ACI Materials Journal*; Vol. 97, pp. 526-535.
- Khayat, K.H. Optimization and Performance of Air-Entrained, Self-Consolidating Concrete. *ACI Materials Journal*.
- Kuchma, D.A., "Contribution of Stirrups to Shear Resistance," *Proceedings of the 2009 Structures Congress: Don't Mess with Structural Engineers – Expanding Our Role*, Austin, Texas, April 2009, pp. 1587-1594.
- Laskar, A., Hsu, T.T.C., and Mo, Y.L., "Shear Strengths of Prestressed Concrete Beams Part 1: Experiments and Shear Design Equations," *ACI Structural Journal*, V. 107, No. 3, May-June 2010, pp. 330-339.
- MacGregor, James G, and Janes K. Wight. Reinforced Concrete Mechanics and Design. Saddle River, NJ: Prentice Hall, 205.
- Myers, J.J. (1998). "Production and Quality Control of High Performance Concrete in Texas Bridge Structures;" *Dissertation*, University of Texas—Austin.
- NCHRP Report 549 (2005); "Simplified Shear Design of Structural Concrete Members;" National Cooperative Highway Research Program; Washington DC.
- NCHRP Report 628 (2009); "Self-Consolidating Concrete for Precast, Prestressed Concrete Bridge Elements;" National Cooperative Highway Research Program; Washington DC.

Sonebi, Mohammed, Steffen Gruneald, and Joost Walraven. (2007); "Filling Ability and passing Ability of Self-Consolidating Concrete" ACI Materials Journal; Vol. 104, pp. 162-170.

Tureyen, A. Koray, and Robert J. Frosch. "Concrete Shear Strength: Another Perspective" ACI Structural Journal; Vol. 100, pp. 609-615.

VITA

Mark Daniel Ezzell was born in Glendale, AZ on July 12, 1986. Mark graduated in May of 2004 from Metamora Township High School in Metamora, IL. After graduation he attended Illinois Central College from August of 2004 through May of 2006. In August of 2006 he transferred to Missouri University of Science and Technology, which was at that time the University of Missouri-Rolla. In May of 2009 he received his Bachelors of Science Degree in Civil Engineering. In August of 2009 he enrolled in the Master of Science program as a structural engineering student at Missouri S&T where he conducted research developing and testing Self-Consolidating Concrete. He maintained membership in the American Concrete Institute (ACI) and has served as the president and student advisor for the Missouri S&T Concrete Canoe Team.