

---

Masters Theses

Student Theses and Dissertations

---

2008

## A hybrid sensor network for watershed monitoring

John R. Koch

Follow this and additional works at: [https://scholarsmine.mst.edu/masters\\_theses](https://scholarsmine.mst.edu/masters_theses)



Part of the [Electrical and Computer Engineering Commons](#)

Department:

---

### Recommended Citation

Koch, John R., "A hybrid sensor network for watershed monitoring" (2008). *Masters Theses*. 5434.  
[https://scholarsmine.mst.edu/masters\\_theses/5434](https://scholarsmine.mst.edu/masters_theses/5434)

This thesis is brought to you by Scholars' Mine, a service of the Missouri S&T Library and Learning Resources. This work is protected by U. S. Copyright Law. Unauthorized use including reproduction for redistribution requires the permission of the copyright holder. For more information, please contact [scholarsmine@mst.edu](mailto:scholarsmine@mst.edu).



A HYBRID SENSOR NETWORK FOR WATERSHED MONITORING

by

JOHN R. KOCH

A THESIS

Presented to the Faculty of the Graduate School of the

MISSOURI UNIVERSITY OF SCIENCE AND TECHNOLOGY

In Partial Fulfillment of the Requirements for the Degree

MASTER OF SCIENCE IN ELECTRICAL ENGINEERING

2008

Approved by

Dr. Sahra Sedigh Sarvestani, Advisor

Dr. Estella Atekwana

Dr. Steven Grant

© 2008

JOHN R. KOCH

All Rights Reserved

## ABSTRACT

This thesis discusses the Hydrological Hybrid Communication Sensor Network (HHCSN), which is designed for in situ measurement of various hydrological properties of a watershed. HHCSN is comprised of a network of sensor strings, each of which connects up to 100 sensing nodes on a communication line as long as 100 m. Each node includes sensors that measure soil attributes of interest, as well as a microcontroller with basic communication and processing capabilities. A relay point at the surface compresses data from the nodes and wirelessly transmits it to a base station that serves as a gateway to the outside world. The base station compresses data from multiple strings and utilizes the GSM cellular infrastructure to communicate the data to a remote server and to receive software updates to be disseminated to the sensor strings. Ultra-low power design and remote maintenance result in an unattended field life of over five years. The system is scalable in area and sensor design modality, as covering a larger area would only entail the addition of sensor strings, and the nodes are designed to facilitate the interfacing of additional sensors. The system is robust, as the only exposed portion is the relay point. Data collection and transmission can be event-driven or time-driven. Battery power, which is supplemented by solar harvesting, and wireless short- and long-range communication, eliminate the need for surface wiring, significantly reducing the cost of system deployment. Currently, the estimate is a cost of less than \$40 for each sensor string, which compares very favorably to the price of existing systems, most of which offer very limited in situ measurement capabilities, yet cost tens of thousands of dollars.

## ACKNOWLEDGMENTS

I would like to express my deepest gratitude to my advisor, Dr. Sahra Sedigh Sarvestani, for patiently guiding me throughout my research.

I would also like to thank Dr. Estella Atekwana for her insightful comments throughout this research. Her experience in the field and knowledge of the geophysical domain has been extremely helpful to my work.

Also, I would like to thank Dr. Steven Grant for serving on my committee and providing insightful comments.

Special thanks go to my parents, James and Carole, who have always believed in me and supported me.

I would also like to thank Justin Enderle, Nathan Publow, Mahsa Dornajafi, and Vaishalee Naruka for their invaluable assistance in developing the TDT/TDR sensor.

The research presented in this thesis was supported in part by the Office of Naval Research through a SMART Graduate fellowship, and in part by the United States Department of Transportation.

## TABLE OF CONTENTS

	Page
ABSTRACT . . . . .	iii
ACKNOWLEDGMENTS . . . . .	iv
LIST OF ILLUSTRATIONS . . . . .	vii
LIST OF TABLES . . . . .	ix
 SECTION	
1 Introduction . . . . .	1
2 Background and Literature Review . . . . .	3
2.1 Background . . . . .	3
2.2 Literature Review . . . . .	5
3 Design Objectives . . . . .	10
3.1 Autonomy . . . . .	10
3.2 Accuracy . . . . .	10
3.3 Low Cost . . . . .	10
3.4 Sustainability . . . . .	11
3.5 Scalability . . . . .	12
4 Hardware Architecture . . . . .	13
4.1 Sensor Node . . . . .	13
4.2 Communication Access Point . . . . .	17
4.3 Base Station . . . . .	20
4.4 Communication . . . . .	22
4.5 Power . . . . .	27
5 Software Architecture . . . . .	31
5.1 Network Creation . . . . .	31
5.2 Base Station . . . . .	32

5.2.1 Main Microcontroller . . . . .	33
5.2.2 Zigbee Microcontroller . . . . .	35
5.3 Communication Access Point . . . . .	37
5.3.1 Main Microcontroller . . . . .	37
5.3.2 Zigbee Microcontroller . . . . .	39
5.4 Sensor Node . . . . .	41
6 Project Status and Evaluation . . . . .	43
6.1 System Status . . . . .	43
6.2 Cost . . . . .	44
6.3 Power Consumption . . . . .	45
6.4 Accuracy of Measurements . . . . .	47
7 Conclusions and Future Work . . . . .	49
APPENDICES	
A BASE STATION. . . . .	50
B COMMUNICATION ACCESS POINT. . . . .	53
C POWER CIRCUITRY. . . . .	58
D SENSOR NODE. . . . .	62
E FLOW CHARTS FOR BASE STATION SOFTWARE. . . . .	66
F FLOW CHARTS FOR COMMUNICATION ACCESS POINT SOFTWARE. . . . .	72
G FLOW CHART FOR SENSOR NODE FLOW SOFTWARE. . . . .	77
H POWER CONSUMPTION ESTIMATES. . . . .	79
BIBLIOGRAPHY . . . . .	84
VITA . . . . .	87



## LIST OF ILLUSTRATIONS

Figure	Page
4.1 Overview of HHCSN . . . . .	14
4.2 Layout of the Sensor Node . . . . .	14
4.3 Schematic of the Sensor Node . . . . .	16
4.4 Layout of the Communication Access Point . . . . .	17
4.5 Schematic of the Communication Access Point . . . . .	19
4.6 Prototype of the Communication Access Point . . . . .	20
4.7 Layout of the Base Station . . . . .	21
4.8 Schematic of the Base Station . . . . .	22
4.9 Sensor String . . . . .	24
4.10 Pegasus Routing . . . . .	25
4.11 Leach-C Routing . . . . .	25
4.12 Combined Routing Scheme . . . . .	26
4.13 Layout of the Power Circuitry . . . . .	28
4.14 Schematic of the Power Circuitry . . . . .	30
5.1 Network Organization . . . . .	33
5.2 Flow Chart of Base Station Setup . . . . .	34
5.3 Flow Chart of Communication Access Point Setup . . . . .	38
5.4 Flow Chart of Sensor Node Setup . . . . .	42
A.1 Layout of the Base Station (Large) . . . . .	51
A.2 Schematic of the Base Station (Large) . . . . .	52
A.3 PCB of the Base Station (Large) . . . . .	52
B.1 Layout of the Communication Access Point (Large) . . . . .	54
B.2 Schematic of the Communication Access Point (Large) . . . . .	55
B.3 PCB of the Communication Access Point (Large) . . . . .	56

B.4	Prototype of the Communication Access Point (Large) . . . . .	57
C.1	Layout of the Power Circuitry (Large) . . . . .	59
C.2	Schematic of the Power Circuitry (Large) . . . . .	60
C.3	PCB of the Power Circuitry (Large) . . . . .	60
C.4	Prototype of the Power Circuitry (Large) . . . . .	61
D.1	Layout of the Sensor Node (Large) . . . . .	63
D.2	Schematic of the Sensor Node (Large) . . . . .	64
D.3	PCB of the Sensor Node (Large) . . . . .	65
E.1	Flow Chart of the Base Station Operation - Level 1 . . . . .	67
E.2	Flow Chart of the Base Station Operation - Level 2 Item 1 . . . . .	68
E.3	Flow Chart of the Base Station Operation - Level 2 Item 2 . . . . .	69
E.4	Flow Chart of the Base Station Operation - Level 2 Item 3 . . . . .	70
E.5	Flow Chart of the Base Station Operation - Level 2 Item 4 . . . . .	71
F.1	Flow Chart of the Communication Access Point Operation - Level 1 . . . . .	73
F.2	Flow Chart of the Communication Access Point Operation - Level 2 Item 1 . . . . .	74
F.3	Flow Chart of the Communication Access Point Operation - Level 2 Item 2 . . . . .	75
F.4	Flow Chart of the Communication Access Point Operation - Level 2 Item 3 . . . . .	76
F.5	Flow Chart of the Communication Access Point Operation - Level 2 Item 4 . . . . .	76
G.1	Flow Chart of the Sensor Node . . . . .	78

**LIST OF TABLES**

Table	Page
6.1 Cost Analysis . . . . .	45
6.2 Power Analysis: Sensor Node . . . . .	45
6.3 Power Analysis: Communication Access Point . . . . .	46
6.4 Power Analysis: Base Station . . . . .	47
6.5 Power Analysis: Power Circuitry . . . . .	47
6.6 Power Consumption . . . . .	47
6.7 Nominal Accuracy of Measurements . . . . .	48

# 1 INTRODUCTION

Advances in geophysics, especially in hydrological modeling, rely on the availability of accurate, high-resolution data about various soil properties. For watersheds in particular, such information is needed across a large area, and at multiple depths of the soil [1]. The data collected by existing hydrological monitoring systems is limited in spatial and temporal resolution, due to both cost, and lack of system autonomy. Site visits by experts are required for data collection, as well as for system maintenance.

Along with the ability to leave the equipment in the field for extended periods of time, creating low cost measurement systems makes it possible to increase the spatial resolution of the data, or alternatively, cover a larger area. This increased spatial resolution gives a more complete picture of the processes at work in the soil and enables the construction of a hydrological snapshot of a large area. Networked, in situ measurement devices also decrease the delay between the measurements required to occur concurrently over the entire area being monitored.

While measurement systems that can be left on site do exist, they are expensive and fragile. Such systems usually use a data logger wired to probes. The data logger must be encased in a protective structure to prevent damage from the elements, because it has not been specifically designed to remain in the field for long periods. Another limitation of the majority of existing systems is high power consumption, which necessitates expensive wiring and easy access to the power grid.

The aforementioned shortcomings in cost, site disruption, and accuracy can be addressed by using autonomous embedded systems in conjunction with a widespread sensor network. The solution proposed in this thesis is the Hydrological Hybrid Communication Sensor Network (HHCSN). This autonomous system uses wired and wireless communication to connect a network of sensor strings installed throughout a watershed. Each sensing string is comprised of multiple nodes placed at different depths of the soil that carry out in situ measurement of properties of hydrological interest. Concurrent measurement at several points across the surface, as well as below the surface, allows for accurate analysis of the watershed environment. Use of

the cellular phone network for remote configuration and data collection, as well as battery power supplemented by solar harvesting, eliminate the need for surface wiring and significantly reduce the cost of system deployment and maintenance.

Commercial platforms for wireless sensor networks, such as TMote [2] and Crossbow [3] motes, have been developed in recent years. The unique needs of hydrological monitoring limit the use of such platforms, which typically offer an unattended field life of approximately one year, have limited communication capabilities, and are fragile. HHCSN is designed for autonomous long-term operation, offers local data storage and regular or on-demand reporting to a remote data repository, and is purpose-built to withstand the elements. The system supplies multi-purpose software that enables the plug-and-play addition of sensors. The simplicity of the software increases dependability and facilitates troubleshooting. Utilization of a general-purpose mote for hydrological monitoring would require considerable effort in hardware development and would result in a more expensive, but inferior system in terms of unattended field life, and long-range communication and sensing capabilities.

The remainder of this thesis is organized as follows. Section 2 provides a background for the sections to follow, and presents a review of related literature. Section 3 details the objectives of this project in creating a watershed monitoring network. Section 4 describes the network architecture of HHCSN. Section 5 details the system operation. Section 6 presents an evaluation of HHCSN, in terms of cost, power consumption, and accuracy of measurements. Section 7 concludes the paper and describes planned extensions to the research.

## 2 BACKGROUND AND LITERATURE REVIEW

This section provides a brief background of the concepts and technologies underlying this research and an overview of related work. Communication standards and sensing techniques used in the project are described. Finally, a summary of related studies is provided, where the systems and projects discussed include relevant sensing systems for domains other than hydrology.

### 2.1 Background

The Global System for Mobiles (GSM) [4] standard is used in HHCSN for long-range communication with the outside world. GSM is used worldwide for cellular telecommunications in over 200 countries. GSM operates on four frequencies: 850 MHz, 900 MHz, 1800 MHz, and 1900 MHz. Transmission power is limited to a maximum of 2 W in GSM 850/900 and 1 W in GSM 1800/1900. GSM has a practical transmission distance of 22 miles. Use of a repeater or amplifier can greatly increase the distance, at the cost of possible loss of quality. The 1999 release of the GSM standard added high-speed data transmission through the introduction of enhanced data rates for GSM evolution (EDGE) [4]. GSM uses A5/1 and A5/2 stream ciphers to encrypt the data being transmitted.

Zigbee communication [5], an IEEE 802.15.4 [6] implementation, is used for short-range wireless communication throughout HHCSN. Zigbee is a low power, low data rate carrier-sense multiple access with collision avoidance (CSMA/CA) communication protocol. The specification was ratified in 2004 and updated in December 2006. Zigbee allows for data rates from 20 kbits/sec to 250 kbits/sec over distances up to 80 meters without amplification. However, ranges of over one kilometer have been reported when signal amplifiers are used in conjunction with Zigbee. For HHCSN, the range required is less than 50 meters, so amplifiers are not required and have not been implemented. The power required for transmission or reception with Zigbee over a distance of up to 80 meters is approximately 30 mA. This is significantly less than that of alternative technologies for short-range communication, such as Bluetooth [7] or WUSB [8], which would require 180 mA and 74 mA, respectively.

The controller area network (CAN) protocol was developed in 1988 by Intel and Robert Bosch [9]. It is primarily used in automotive applications to enable reliable serial communication. The ISO-11898 standard for CAN specifies details for the lower two levels of the standard seven-layer OSI networking model, but the medium for communication was intentionally omitted to allow use of multiple media for maximum flexibility. CAN is a carrier-sense multiple-access with collision detection (CSMA/CD) communication protocol [10]. Since CAN uses a differential bus to communicate, it can perform non-destructive bitwise arbitration. This ability allows for priority messages to be sent without requiring retransmission in the event of a collision, which is very important in real-time applications. CAN has only two priority levels, but additional levels can be defined with proper message encoding. Successful bit-wise arbitration allows for any data rate up to 1 Mbits/sec to be achieved over any distance. CAN specifications allow for data rates of 40 kbits/sec to 1 Mbits/sec. The determining factor is the distance to be traveled and the medium used for communication. As long as bitwise arbitration can be successfully performed, any distance can be chosen, at any data rate up to 1 Mbits/sec.

A time-domain reflectometer (TDR) is a sensor that evaluates the electrical characteristics of an environment by measuring a reflected pulse. A TDR transmits a pulse with a fast rise time along a conductive probe. The composition of the material surrounding the tip of the probe determines what happens to the transmitted pulse, from full absorption to complete reflection. The reflected pulse is a function of the conductivity, length, and relative permittivity of the material surrounding the conductive probe. Since the relative permittivity of each material is unique, it can be used to determine the material composition, including the moisture level, which is the parameter of interest here. Since TDR is a non-destructive method of measurement, multiple measurements can be performed on a single sample, allowing accurate evaluation of the moisture content of the material.

A time-domain transmissometer (TDT) is a sensor that evaluates the electrical characteristics of an environment by measuring the reaction to a transmitted pulse. A TDT transmits a pulse with a fast rise time along the conductive transmission line. The delay experienced by the signal depends on the composition of the material surrounding the transmission line. This delay is a function of the conductivity, length,

and relative permittivity of the material surrounding the conductive probe. Since the relative permittivity for each material is unique, the material composition can be determined in a manner similar to the TDR method of measurement. As for the TDR, the moisture content of the material is the parameter of interest.

The design and implementation of the TDT used in the HHCSN was performed as a senior design project by a group of four undergraduates in electrical and computer engineering, Justin Enderle, Nathan Publow, Mahsa Dornajafi, and Vaishalee Naruka. Preliminary laboratory testing of the TDT sensor in air, water, and various saturations of soil validated correct operation. The nominal operation of the sensor is 90 picoseconds, which enables calculation of relative permittivity within two tenths of a degree. Commercial TDT sensors are prohibitively expensive and this high cost was one of the main motivators for the development of an alternative. The TDT developed has a total cost of \$5 in unit production, which compares favorably to commercial sensors that cost hundreds of dollars.

Electrical resistivity is a measure of how strongly a material opposes electrical current. Knowledge of the voltage across and current through a material allows determination of its resistance:  $R = \frac{V}{I}$ . Knowledge of the resistance and temperature in turn allows characterization of the material with relation to known properties such as the types and concentrations of materials in the soil.

## 2.2 Literature Review

This section summarizes related work in network architectures and sensing systems, approaches, and methods for environmental monitoring.

The Tenet architecture described in [11] has potential for being used in static sensor networks. The architecture is very lightweight and dynamic. However, its current form has many serious limitations, including very short battery life resulting from its mobility, which requires that the device remain online for longer periods, and that the node information be updated more frequently. Other limitations of the system are most likely direct results of the increased overhead required to manage the mobile devices.



Environmental observation networks such as Water and Environmental Research Systems (WATERS) [12], GeoSWIFT [13], Sensorweb [14], and Networked Infomechanical Systems (NIMS) [15] have been developed in several studies. WATERS [12], as of March 2008, proposes the use of a network of existing satellites along with the deployment of ground-based in situ sensors. The purpose of this system is to monitor areas of hydrological interest, such as watersheds. The data collected will be incorporated into a high-performance cyber-infrastructure. While the sensors, systems, and infrastructure proposed in [12] are impressive, this network has yet to progress beyond the feasibility study, as opposed to the HHCSN network, for which the infrastructure and sensors have already been implemented.

Many large-scale environmental observation networks rely heavily on satellites. Sensorweb [14], an example of such a network, focuses on the macroscopic level of environmental observation. Similar to WATERS, this network uses in situ sensors with satellites to detect environmental events. Triggers for these events are loaded into a re-tasking system that coordinates with the appropriate satellite system for observation. While this system is beneficial and necessary for understanding large scale events, it misses the small scale details and relies heavily on expensive satellites. This network relies on the capabilities of the in situ sensors for long-range communication.

Mobile environmental observation systems such as Networked Infomechanical Systems (NIMS) [15] use a combination of mobile sensing platforms and fixed sensors. This combination allows the NIMS system to avoid obstacles and perform three-dimensional monitoring. However, the system has limitations in sustainability. Mobile sensing platforms are far more prone to possibility of malfunction of a critical part of the network. This fragility is detrimental to the consistency of subsequent readings. Furthermore, movement of the platform consumes considerable energy, which necessitates more frequent battery changes and reduces the power available for more important tasks, such as sensing and communication.

The hydrological sensor web described in [16] and [17] contains sensors for humidity, soil temperature, light levels, and soil moisture, and employs wireless communication. While this system appears similar to HHCSN, significant differences exist. The sensor network used in [16] utilizes a proprietary 900 MHz wireless communication protocol, which complicates simple network expansion, in contrast to HHCSN,

which uses an open standard. Moreover, the measurements carried out by the network in [16] are intrusive, and limited to surface level and a depth of 0.5 meters. Furthermore, while the battery life of the system is not detailed in published work, from examination of the sensors, communication, and limited solar harvesting used, it can be surmised that the batteries will have to be replaced at least once in a three-year period.

The wireless sensor network in [18] is intended for flood monitoring. Scalability, energy harvesting, and low power use are fittingly cited as the principle considerations in design of this system. The rapidly evolving nature of floods necessitates real-time monitoring, which results in high power consumption. The major shortcoming of the large-area sensor network in [18] is its cost, which is due primarily to the cost of the PDAs being used as sensing platforms.

Current systems for measurement of soil properties are large in size and require on-site expert personnel to operate. For example, Jackson et al. [19] used an airborne electronically-steered L-band radiometer (ESTAR) to measure surface soil moisture, and compared the readings to ground observations using the gravimetric method and microwave radiometer measurements. All three of these methods require on site personnel. The ESTAR system also requires the use of a C-130 aircraft. HHCSN eliminates the need for such large and costly equipment. Moreover, it utilizes long-range wireless communication for data reporting and remote maintenance, which considerably reduces the need for intervention by skilled personnel.

An automated wildlife monitoring network has been described in [20]. It uses a small personal computer called a CENS node. While this system provides greater computational power, easier interfacing, and improved expandability as compared to similar systems, it has shortcomings such as low battery life, high cost, and extraneous hardware capabilities that needlessly increase the complexity of the system. Furthermore, the sole sensor on these nodes is a microphone with software to analyze the received signal. Therefore, while the base system could be used in a hydrological application, the lack of required sensors precludes this use.

The design and field testing of a sensor network for measurement of soil moisture is described in [21]. The system is based on Mica2<sup>®</sup> motes and employs various types of sensors that coordinate with the network to react to external stimuli such

as precipitation. When the network detected that it was raining, it would increase the sampling rate of the soil moisture sensors, later returning it to the normal lower rate when the rain stopped. The network routing was static, with a number of the nodes dedicated to routing messages. The base station of the network was connected to a remote database server via the GSM network. The most significant difference between the method described in [21] and the method in HHCSN is the depth of the measurements. The former system measures soil moisture only at the surface, while the latter can measure below the surface to a depth of 100 m using buried sensors.

The lack of sub-surface measurement capability is a shortcoming of most existing soil measurement systems. Geophysical processes happen both on and below the surface of the soil. Current techniques of measuring subsurface processes include gravimetric, dielectric, ultrasonic, spectroscopic, electromagnetic, thermal, and nuclear methods [22]. These methods are labor-intensive, power-hungry, and expensive.

Another shortcoming of existing subsurface measurement methods is their requirement that a site sample be removed and analyzed. For example, in gravimetric methods [22], a soil sample is removed, weighed, dried, and then weighed again. The difference in weight is assumed to reflect the moisture in the soil for an estimated area. This process of removing a sample from the site disrupts the very property being measured. Since the soil was removed, the measurements of the sample reflect the state of the site before the sample was taken, instead of its current state. The disruption also limits the rate at which useful measurements can be taken. In situ testing methods, such as the techniques employed in HHCSN, eliminate the need for taking samples and facilitate a considerable increase in the measurement rate of soil properties.

Two other soil property measurement techniques, specific potential (electric potential of a specific material) and resistivity measurements [23], also require onsite personnel and can involve large equipment, depending on the measurement requirements. The measurements can be taken manually with a multi-meter, or the probes can be connected to a large data logging device that is typically vulnerable to the elements and requires that a costly shelter be built for it and its external power supply.

A fiber optic method for measuring soil properties has been presented in [24]. While this method has a temperature resolution of  $\pm 0.01^\circ\text{C}$ , its spatial resolution is in the meter range. The system is fairly expensive, due to the fiber optics. Even though HHCSN has only a temperature resolution of  $\pm 1^\circ\text{C}$ , its spatial resolution is in the centimeter range, and it is at least an order of magnitude less expensive.

Doolin and Sitar [25] describe two field tests of wildfire monitoring with WSNs. The sensors used were based on Mica2<sup>®</sup> motes interfaced with a sensor board containing temperature, relative humidity, barometric pressure, light, and acceleration sensors. Each mote failed to transmit data at some time during the tests, but reliable data was still collected, due to the redundancy achieved by the large number of motes. These tests show that useful data can be collected despite the failure of a considerable number of nodes. HHCSN also uses hardware redundancy to increase the availability and dependability of measurements.

The aforementioned studies underscore the need for novel environmental monitoring systems that are low-cost, perform in situ testing, and collect and report accurate data without the intervention of onsite experts. Low power consumption is a very desirable feature, because it increases the unattended field life of the device. A small, inconspicuous, and rugged device can considerably lower costs, because it survives exposure to the elements without requiring protective housing. The remainder of this thesis elaborates on the novel approach taken by HHCSN to meet these specifications.

### 3 DESIGN OBJECTIVES

This section articulates the main design objectives of the proposed hydrological monitoring system, specifically, autonomy, accuracy, low cost, sustainability, and scalability. These objectives were selected to address the shortcomings of the existing systems described in Section 2.

#### 3.1 Autonomy

One of the most costly aspects of any monitoring network is the need for site visits by experts. These visits are often necessary for data collection, system maintenance, and configuration changes. Long-range communication capability allows these tasks to be carried out remotely, which increases the autonomy of the network. Ultra-low power design and power harvesting further increase the unattended field life by significantly reducing the number of battery replacements required. Remote access also facilitates data collection from hostile terrain, or under extreme weather conditions. HHCSN uses the GSM cellular phone infrastructure for long-range communication, which allows for access and control from almost anywhere in the world. Specifically, data retrieval, software updates, system configuration, and error analysis can all be performed remotely.

#### 3.2 Accuracy

Accuracy and integrity of data collection are the two primary concerns in the design of any system intended for measuring, recording, and reporting accurate, precise, and complete information. HHCSN utilizes high-resolution sensors, redundancy, and data corroboration to ensure the accuracy of the collected data. Integrity of information is ensured through EEPROM data storage, lossless compression, and 128-bit encryption. Sensor resolutions are specified in Section 6. These are nominal values and will be validated through laboratory and field testing of HHCSN.

#### 3.3 Low Cost

A primary shortcoming of existing monitoring systems is their cost, which is often prohibitively expensive [26], [24]. In designing HHCSN, the objective was to

create a low-cost base system that could be customized as determined by the monitoring requirements. Low-cost off-the-shelf components were used for the sensors, communication devices, and microcontrollers. Where commercial components were deemed too costly, as in the case of sensors for measurement of soil moisture, low-cost alternatives were implemented that offered the required functionality and a simple design. A combination of wired underground and wireless above-ground communication was used to avoid the expensive wireless transceivers required to facilitate dependable underground communication.

### 3.4 Sustainability

Achieving system sustainability, in terms of environmental impact and autonomous operation, was one design objective of HHCSN. As a basis, ultra-low power integrated circuits were used where possible. Additionally, components were placed in sleep mode and activated only as needed to provide accurate measurement without continuous power consumption. Data compression was used to reduce the volume of data communicated, in an effort to reduce the power associated with wireless communication, which is the single largest energy drain in any wireless sensor network. Energy-sensitive wireless communication protocols, including Zigbee (described in Section 2), were used to further reduce this cost.

The battery life of the system was further extended by harvesting solar energy. Wireless surface communication and battery power eliminated the need for digging trenches for phone and power lines, which would disturb the measurement site and increase the footprint of the system.

Physical robustness is one of the main determinants of the longevity of any hydrological monitoring system. In HHCSN, PVC pipe was used to encase the underground components. Batteries were insulated to protect them from rapid temperature swings, and IP68-compliant casing was used for the all above-ground devices. IP68 [27] compliance guarantees that the enclosure of the device will tolerate dust, corrosion, explosion, and submersion. All components were selected to be compliant with Restriction of Hazardous Substances (RoHS) requirements [28] to minimize their

environmental impact. Long-range communication capability was included to reduce or eliminate the need for site visits, minimizing watershed disturbance.

### **3.5 Scalability**

HHCSN was designed to be scalable in terms of sensor design modalities, area monitored, and resolution. The area or resolution can be increased by adding sensor strings, and additional soil parameters can be measured by a simple plug-and-play addition of sensors to each node prior to implementation. The hardware and software of HHCSN were designed to facilitate these additions.

To obtain a highly scalable sensor network, prudent addressing is key. For sensing networks in which the information gathered is only meaningful in the context of the location, a unique address is required for each point where measurements are taken. However, regular transmission of sending an address long enough to handle a widely expansive network would be a poor use of time and energy. Thus a dynamic addressing scheme is required. The use of a remote server facilitates dynamic addressing of the network by performing the required mapping, allowing a virtually unlimited network to be supported. Section 4 elaborates upon this technique.

## 4 HARDWARE ARCHITECTURE

HHCSN is an embedded, in situ sensor network built from the ground up to meet the needs of large-scale watershed monitoring and the objectives mentioned in Section 3. The focus on ultra-low power design and the use of power harvesting allows for maximal sensing and communication and ensures several years of operation between battery replacements, as detailed in Section 6. Each device in HHCSN is enclosed in an IP68 compliant casing to protect its components from the environment.

HHCSN is hierarchically organized into three levels: (1) sensor, (2) control access, and (3) external network connection, as seen in Figure 4.1. The sensor nodes constitute the lowest level of the hierarchy. Their sole responsibility is sensing physical phenomena and storing the resulting data until it can be collected. The second level of the hierarchy, denoted as the control access level, includes the communication access points (CAP) and the base stations. The responsibilities of each CAP are to control a group of sensor nodes, collect the data obtained by these sensor nodes, and act as a connection between that group and the rest of the network. The group of sensor nodes and the CAP that controls them form a sensor string. Also included in the second level are the base stations, which control the CAPs across the network, gather data from them, and connect the system to the outside world through the external network connection, which forms the third and top level of the HHCSN hierarchy.

### 4.1 Sensor Node

The sensor nodes operate at the lowest level of the system hierarchy. The functions of each node are to operate the sensors that are on it and to communicate the results to the CAP of the sensor string. The computational capabilities of the sensor nodes were kept to a minimum to reduce costs and to enforce simplicity and separation of concerns within the system. The sensor node does not have an internal power source and depends on power sent from the CAP. The layout design of the sensor node can be seen in Figure 4.2. The schematic of the sensor node is depicted in Figure 4.3.



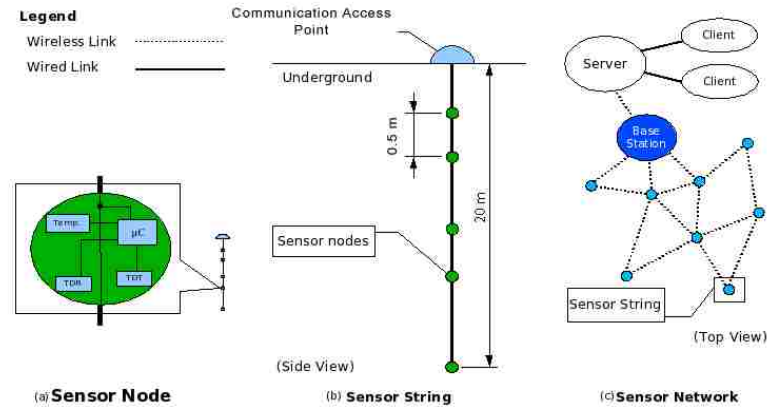

Figure 4.1. Overview of HHCSN

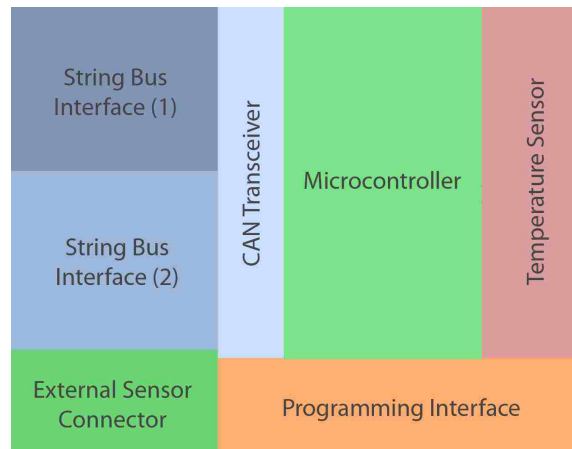

Figure 4.2. Layout of the Sensor Node

The connection between each node and the CAP is a Category 5e STP network cable with standard RJ-45 connectors. This cable contains four twisted pairs of wire, of which two wires are used for CAN communication, two for positive voltages (3.3 V and 5 V), two for ground lines, and two for sensor node interrupts. One of the interrupt lines is used to wake the device out of its ultra-low power sleep state and the other interrupt is currently unassigned.

Once all sensor nodes are awake and listening to the line, instructions are given to each node or, in some instances, pair of nodes; the latter of which is required

for measurement of resistivity. These instructions can specify that a sensing routine be performed, or may contain a software update. When a sensor node completes a sensing routine, it transmits the data and its node identification number to the CAP and continues on to carry out the next instruction it was given. The sensor node does not interpret or process any of the information it collects through its sensors, which allows for changing interpretation of the sensor information without the necessity of updating the software of the sensor node. Once all instructions have been carried out, the sensor node goes into an ultra-low power sleep state, from which it can only be awakened by the CAP.

Sensors currently on each node are a temperature sensor, a time-domain transmissometry sensor (TDT), a time-domain reflectometry sensor (TDR), and a resistivity IC. These sensors collectively provide information that can be used to accurately characterize the soil in terms of permittivity, resistivity, humidity, and temperature.

The TI TMP411 temperature sensor has an accuracy of  $\pm 1^\circ\text{C}$  and internal and remote sensing capabilities. HHCSN employs the remote capabilities of the temperature sensor to measure exact soil temperatures. In this case, “remote” refers to a location not in the immediate vicinity of the sensor, which uses a transistor probe to come in contact with the soil at this location. A measurement operation by the temperature sensor typically takes 115 ms and uses  $120\ \mu\text{A}$ . The sensor uses a SMBus [29] to communicate with the microcontroller of the sensor node.

As stated previously, the TDT and TDR sensors are essentially the same sensor, only with different probes. The TDT uses a semi-circular probe while the TDR uses a rod-shaped probe. Because of challenges typically involved with installation, both sensors are incorporated. These challenges mainly arise due to soil composition and density. The TDR and TDT sensors both use clock generation and comparators, as well as an A/D on the sensor node microcontroller. Therefore, the result of each sensing operation is a 12-bit number. Using both sensors allows for corroboration of their data, which results in more accurate readings, as they employ different measurement techniques, as described in Section 2.

Sensing the resistivity is actually carried out by a pair of two sensor nodes. One node applies a known voltage to a probe in the soil. The second node of the pair reads the voltage on its probe, a voltage divider with known resistance, and uses the

A/D converter of the microcontroller to measure the current received through the probe. With knowledge of the voltage output and the current received, the resistance of the soil between the two probes can be determined. In this implementation, the CAP signals two nodes to be the pair in a resistivity sensing operation. Since the CAP can ping each node and measure the roundtrip time, the distance between the pair of nodes can be determined. As mentioned above, no information processing is performed by the sensor nodes. The distance and the resistance are both sent as data; they are not used by the sensor node to calculate the resistivity of the soil. As a result

The sensor nodes have been designed to allow the addition of other sensors. To allow for simple expandability, a connector on each board allows new sensor boards to be vertically stacked. These connectors link the sensors, i.e. TDR/TDT, resistivity, temperature on the node, and allow for their addition or removal.

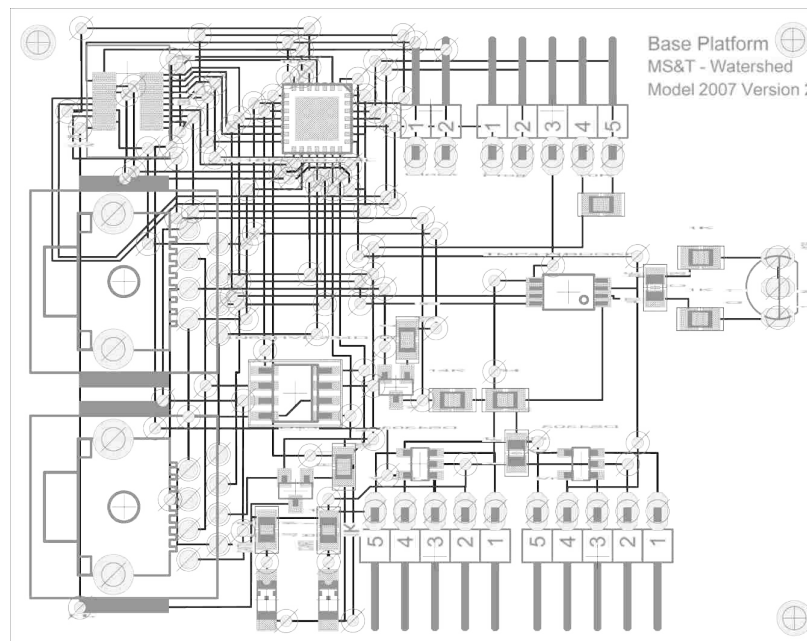

Figure 4.3. Schematic of the Sensor Node

## 4.2 Communication Access Point

The communication access point (CAP) serves as the controller of the sensor string and interfaces it to the remainder of HHCSN. Attached to the CAP is the power supply for all devices on the sensor string. In addition to controlling the sensor string, the CAP stores and compresses the data from sensing operations. Data compression is performed to reduce the storage requirements and transmission time. The CAP uses a CAN transceiver to communicate with the sensor nodes on its string, as well as a Zigbee transceiver, which provides wireless connectivity with the rest of the network. The microcontroller for the CAP is the Microchip PIC18LF2580. The layout of the CAP can be seen in Figure 4.4. The schematic of the CAP is depicted in Figures 4.5; Figure 4.6 presents a picture of the prototype.

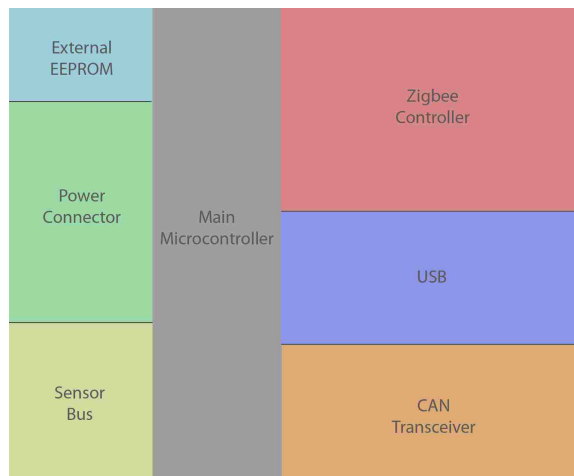

Figure 4.4. Layout of the Communication Access Point

Consolidation of power-related concerns on the CAP simplifies maintenance and troubleshooting. This also allows for the CAP to shut down power to the rest of the sensor string as required for reducing energy consumption. This could occur in a number of situations, including times when the batteries are nearing depletion and the remaining power is needed for transmission of data already collected from the sensor string.

It was initially assumed that having the CAP act as the control unit of the entire sensor string would necessitate that it have significant computing power. However, as the project progressed, it was discovered that the lack of data processing restricted the tasks performed by the CAP to controlling the sensor string and storage, compression, and transmission of the data it collects. The most computationally-intensive of these tasks is compression, and even that can be achieved with fifteen lines of code, as explained below.

As the control unit for the sensor string, the CAP dictates the scheduling of tasks for the sensor string. Simultaneous sensing by multiple nodes on a string can cause errors in measurements that require the application of a voltage to the soil. This necessitates tight scheduling of operations by the CAP to minimize the chance of such errors. Other control tasks carried out by the CAP include awakening, providing instructions to, and gathering results from the sensor nodes for which it is responsible. The CAP wakes all sensor nodes along the string by sending a “high” signal down the interrupt line one of the string. When a sensor node receives this signal, it awakens out of its sleep state and awaits commands. The CAP then sends the scheduled commands to the individual sensor nodes for which they are intended. If a node does not receive a command within a designated time, it turns itself off. Upon completing a task, each sensor node should send a message to the CAP. After a sensor node has failed five times to respond to a message sent from the CAP, the CAP designates that sensor node as “failed”. The CAP alerts the remote server to this occurrence and does not attempt communication with said sensor node thereafter, unless it is explicitly instructed to do so by the remote server.

The CAP handles large amounts of raw data that could be very close in value, and as such, a compression scheme can be very effective in reducing the volume of data to be transmitted. The compression scheme used by the CAP is the Lempel-Ziv-Welch (LZW) compression algorithm [30] [31], which is lossless and very simple to implement. The LZW compression algorithm was chosen due to the very little code required for its implementation, the extent of compression it achieves, and its well-documented use in a variety of applications, e.g., GIF picture format and ZIP file format. Last, but not least, it is free. This scheme is ideal for HHCSN, because it allows for compression and decompression using an algorithm consisting of fewer

than fifteen lines. After the data has been compressed, it is stored in the EEPROM, which is external to the microcontroller. The EEPROM used is a Microchip 25AA256 with 256 kbit storage capacity. When it is time to transmit the data, the EEPROM is activated and the data is transferred to the Zigbee transceiver in increments, until all the data has been sent.

The CAP uses CAN and Zigbee communication. Implementation of these technologies is detailed in Section 4.4. The CAP simply acts as another node along the CAN bus, using an onboard port as its interface to the bus. Since the microcontroller does not have an internal USB controller, a National Semiconductors USBN9604 is used. To reduce space, a USB mini-connector is used. The USB port has been included to allow access to the information in the event that wireless communication cannot be used for collecting the data or sending software updates. The USB port, as any other access point, must be secured to prevent tampering.

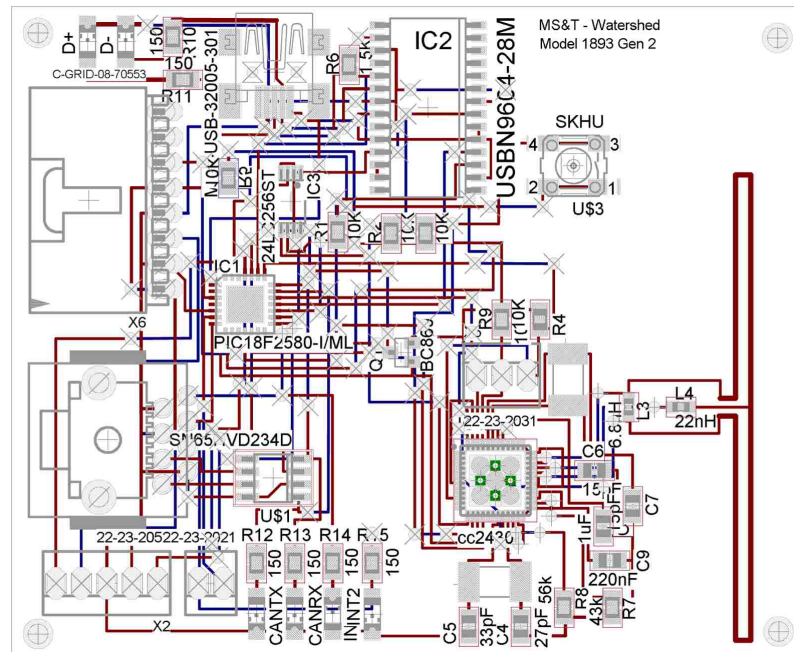

Figure 4.5. Schematic of the Communication Access Point

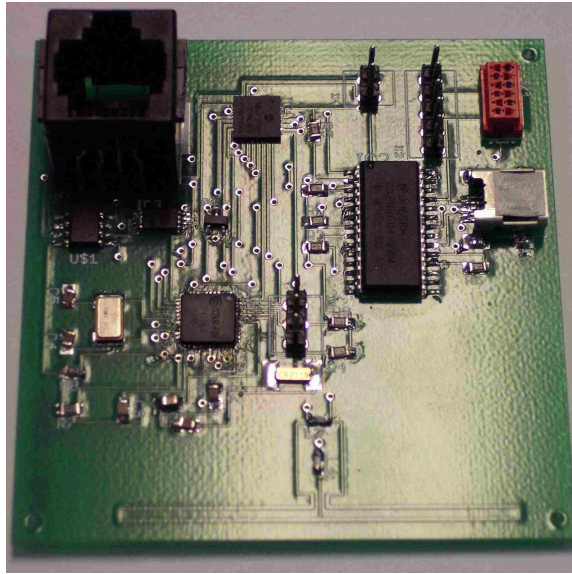

Figure 4.6. Prototype of the Communication Access Point

### 4.3 Base Station

Each base station is the data sink for the multiple CAPs and serves as an interface to the outside world for HHCSN. Its main functions are to initiate maintenance across the network, disseminate software and scheduling updates, and transmit data gathered by the system to an outside location. The components required for carrying out these tasks are memory, a GSM modem, a Zigbee transceiver, and a microcontroller. The microcontroller used for the base station is a Microchip PIC18LF2550. The layout and schematic of the base station can be seen in Figure 4.7 and Figure 4.8, respectively.

The GSM modem selected is a Falcom c55i, due to its reasonable price and support for common AT control commands, which are networking instructions made popular by Cisco. HyperTerminal, a program found on most Windows machines, can be used to operate the modem, enabling easy maintenance. The GSM module includes an internal SIM card reader, an internal TCP/IP stack, and an internal antenna. The internal SIM card reader allows easy switching between cellular service providers. The internal TCP/IP stack allows for FTP access, SMS messaging, email,

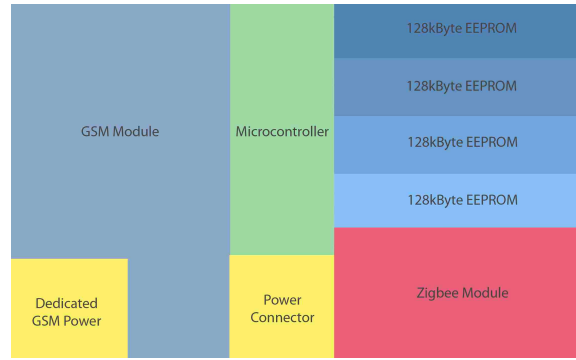

Figure 4.7. Layout of the Base Station

and standard GPRS. GPRS is an expansion of GSM [4] to provide higher data rates. The internal antenna reduces the need for external hardware.

The purpose of the Zigbee transceiver on the base station is to act as the main control unit and data sink for a number of CAPs. These two functions are described in further detail in Sections 4.4 and 5.1, respectively. The base station also has USB communication capability, but no external controller is necessary, because the microcontroller has an onboard USB controller. As in the CAP, a USB mini-connector is used. The purpose of the USB port is to allow for data collection and software updates in the event that wireless connectivity is lost. As with the CAP, it is required that this access point be secured to prevent tampering.

The base station handles the raw data of the entire network, which is likely to have significant repetition of values. Thus, a compression algorithm can be extremely effective in reducing the volume of data to be transmitted. As in the CAP, the compression scheme used for the base station is the LZW algorithm, which is lossless, fast, and very simple to implement. After the data has been compressed, it is stored in the EEPROM, which is external to the microcontroller. There are four EEPROMs on the base station; each is a Microchip 25FC1024 with 1024 kbit storage capacity, providing 4 Mbits of storage space, which is the maximum achievable under current cost constraints.



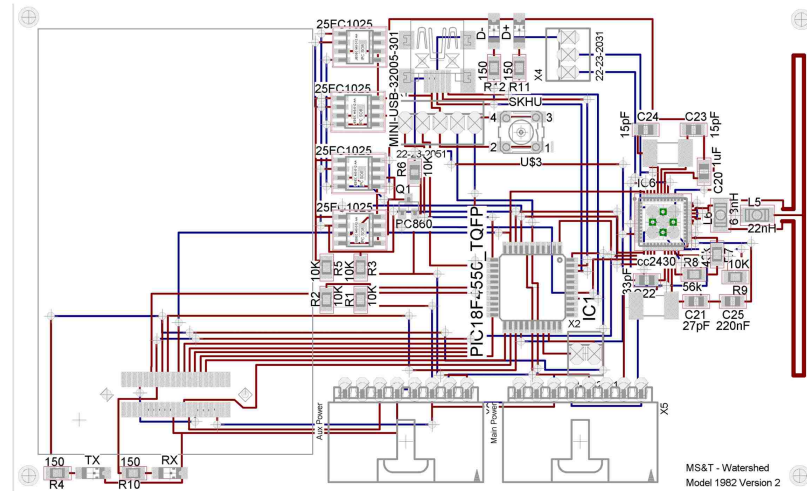

Figure 4.8. Schematic of the Base Station

#### 4.4 Communication

Four main communication techniques are used by HHCSN: I<sup>2</sup>C, CAN, Zigbee, and GSM. A detailed description of each protocol and the rationale for its selection follow.

The inter-integrated circuit (I<sup>2</sup>) bus [32] communication standard is commonly used for internal communication among controllers and sensors of a single device. The I<sup>2</sup>C-bus is a two-wire serial bus used for communication among microcontrollers and external devices over short distances. It was developed by Phillips and standardized in 1992. I<sup>2</sup>C-bus has an address limitation of three bits, which restricts the number of devices on the bus to seven.

SMBus [29] is used, in conjunction with I<sup>2</sup>C-bus, by the microcontroller to communicate with the temperature sensor on the sensor node. The external sensor connector of the node is connected to the I<sup>2</sup>C-bus to allow for sensors added later to communicate with the microcontroller. I<sup>2</sup>C-bus is also used by the CAP and the base station to communicate with external EEPROMs. Serial peripheral interface bus (SPI), a four-wire serial bus, is used to communicate with the Zigbee transceivers on the CAP and the base station. Microcontrollers typically use a single set of pins for

the I<sup>2</sup>C-bus and SPI buses; hence, care should be taken to avoid problems caused by concurrent use of both techniques. Activation of the SPI requires a chip-select pin to be driven, hence, the I<sup>2</sup>C-bus has no effect on the SPI until it is deliberately activated. However, the I<sup>2</sup>C-bus is addressable and has no chip-select line, which allows for an SPI communication to activate it, which can cause conflicts. HHCSN averts this danger by simply powering off all I<sup>2</sup>C-bus devices during SPI communication. This remedy may seem excessive, but all components of HHCSN have been chosen to support rapid power switching, for energy conservation, hence, this operation will not damage the I<sup>2</sup>C-bus devices.

The CAN technique supports wired communication among sensor nodes and the CAP, as depicted in Figure 4.9. CAN communication along the sensor string is performed along a Category 5e shielded twisted-pair at 250 kbits/sec. The twisted-pairs are used to reduce the likelihood of errors caused by stray capacitances along the bus, as power and node interrupts are also sent along the same line. The line was also configured to minimize stray capacitances. This is done by interleaving signal lines with power and ground lines. The shielded cable allows for reliable communication despite environmental changes, because sensing operations can potentially interfere with communication. A CAN bus is used to communicate data and information to and from the CAP to the sensor nodes. All of the microcontrollers used on the sensor nodes and CAPs have CAN controllers. The same model CAN transceiver, the Texas Instruments (TI) SN64HVD234 is used throughout HHCSN to simplify troubleshooting along the bus. This model was chosen because it operates within the voltage range provided, uses little power, and allows for ultra-low (50 nA) sleep current. Other devices from TI and other manufacturers were considered, but the very low sleep current was more beneficial than any of the features offered by other devices.

The Zigbee transceiver, used for medium-range communication on the base stations and CAPs, is the TI cc2430 with the TI Z-Stack. The TI cc2431 was considered because of its ability to determine its own location in reference to other cc2431 transceivers, but since the nodes of HHCSN are not mobile, the added cost was not justified. A transceiver with an independent 8051 microcontroller was chosen instead of a transceiver alone, because it allows Zigbee operation without requiring that the

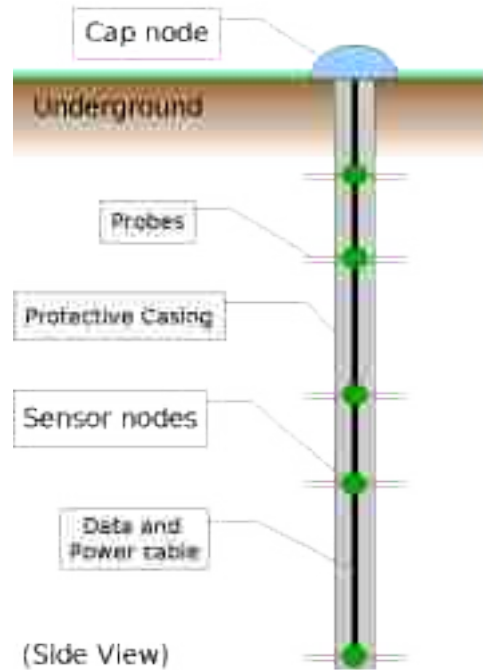

Figure 4.9. Sensor String

Z-Stack take full control of the main microcontroller. The stack must take control of the microcontroller on which it runs to ensure timely receipt of packets. The cc2430 raises an interrupt on the main microcontroller of the unit to indicate that it is ready to transmit more data or has received data for the microcontroller to analyze. It is the duty of the main microcontroller to interpret what the interrupt means and act accordingly.

Zigbee communication within HHCSN uses a combination of two different protocols to create a three-level network that maximizes data throughput and minimizes energy usage. The protocols used in the three levels of Zigbee communication are Hierarchical-Pegasis [33], Leach-C [34], and then Hierarchical-Pegasis. Hierarchical-Pegasis and Leach-C are depicted in Figure 4.10 and Figure 4.11, respectively. This combination results in minimal communication distance, reduces the load on any one CAP, and allows for near-limitless expandability. This is a direct result of dynamic addressing and grouping of CAPs into clusters. The cc2430 Zigbee transceiver handles

all transmission, reception, and network maintenance, relieving the main microcontroller of any responsibility for these details, other than providing the cc2430 with the data to transmit and interpreting the data received.

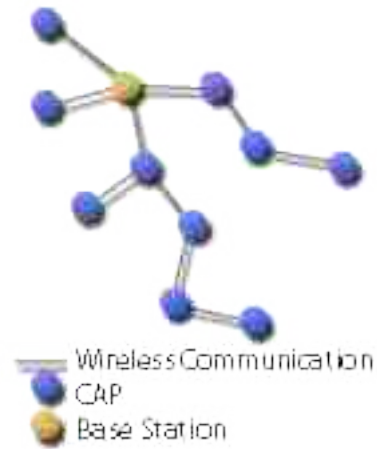

Figure 4.10. Pegasis Routing

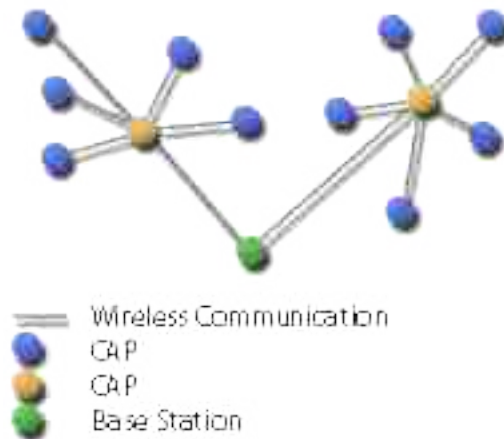

Figure 4.11. Leach-C Routing

The combination of the two protocols can be seen in Figure 4.12. With respect to the HHCSN system, the main sink and sub-sink of Figure 4.12 are the base station and CAP, respectively. Leach-C creates clusters from nodes in the network, with cluster heads being randomly chosen. The intent is to consolidate the high cost of long-distance communication at a single node, then rotate this responsibility within the cluster. A cluster size of twenty nodes was chosen based on the analysis in [34], which demonstrates that this cluster size achieves minimum delay in Leach-C clustering. To keep the network operational, yet minimize energy consumption, it was decided maintenance and reorganization be performed every five Zigbee communication cycles, which is approximately once per day. The procedure for this network creation process is provided in Section 5.

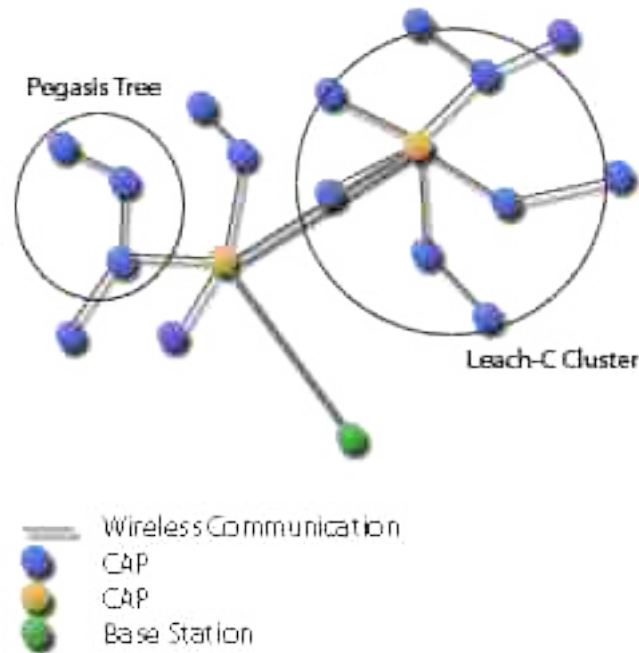

Figure 4.12. Combined Routing Scheme

Since the base station connects to the outside world, it must be equipped with some form of long-range communication. The base station is the only device in

HHCSN that is equipped with a GSM modem. This reduces overall costs and power consumption. The GSM modem used is the Falcom c55i, which is larger than similar devices, but still small enough for the purposes of HHCSN. The c55i provides a low sleep current of  $60 \mu\text{A}$  and relatively low operating current of 290 mA. Even though the GSM module requires very little power, it does require up to 1.6 A pulse strength. Consequently, two power circuitries are needed to provide sufficient instantaneous power. The Falcom c55i can achieve a GSM data rate of 42.8 kbits/sec. The GSM modem is only active when transmitting or receiving data from the outside world. It initiates contact once every twenty sensing cycles, or when the internal storage has reached the point at which it cannot store data from another cycle. The frequency of contact can be adjusted after laboratory and field testing determine the appropriate value.

#### 4.5 Power

The unique system hierarchy and power requirements of HHCSN necessitated design of custom power circuitry. The desire for autonomy dictated that battery replacements be kept to a minimum. Ultra-low power design and harvesting of solar power were used to this end. Redundancy was achieved for the supply of power by using both disposable and rechargeable batteries in conjunction with a solar panel. The ability to use either set of batteries enables replacement of one set of expired batteries while providing an uninterrupted source of power. This flexibility is beneficial when devices are able to sleep, but turning off the power to them causes problems. The layout of the power circuitry can be seen in Figure 4.13. The schematic and prototype are presented in Figure 4.14.

The power circuitry is designed such that it could be powered directly by the solar cells; however, this is not the primary purpose of the solar cells. The main intent of using them is to recharge a battery pack. However, this ability implies that at times, such as during sleep cycles, when minimal power is being consumed, the solar cells can provide sufficient power, eliminating the reliance on batteries.

A battery recharge management integrated circuit was utilized to allow optimal recharge time and minimize the stress on the batteries being charged. This is of particular importance if maximal lifespan is to be achieved for the batteries. Since

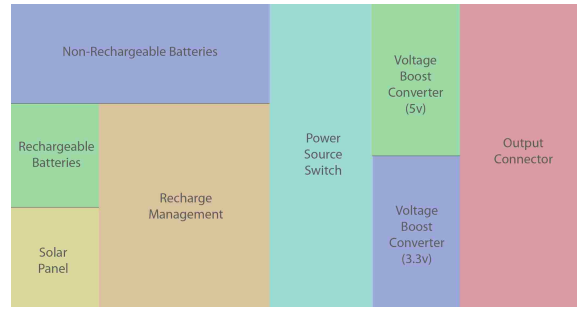

Figure 4.13. Layout of the Power Circuitry

different battery chemistries have different recharge cycle requirements, using a uniform cycle would reduce the physical lifespan of the batteries used. The particular IC selected is the TI BQ2000, which supports lithium, nickel-metal-hydrate (NiMH), and nickel-metal-cadmium (NiCad) cells, with multiple charge termination criteria. This management IC does however, consume energy, typically  $500 \mu\text{A}$ . While this is a significant amount of energy in comparison to other devices in the network, this IC is powered solely by the solar panels, which means that, if the solar panel fails to produce sufficient power to operate the IC, the batteries are not charged. The solar panel used is the Kyocera 1.2 W, 12 V mini solar panel. The solar panel provides 100 mA at 12 V. This solar panel produces sufficient power to run the IC and recharge the battery even during minimal sun light. This solar panel was chosen for its small size of  $24 \text{ in}^2$  and its low price.

The power circuitry incorporates an internal switch, the TI TPS2111A, which enables automatic switching between disposable and rechargeable battery packs. This allows for continuous supply of power at the desired voltage levels. Under normal circumstances, the system is powered by rechargeable batteries. However, if the rechargeable batteries drop below 2 V, the power source is automatically switched to be the disposable batteries. If the disposable batteries fall below 2 V, then the source is switched back to the rechargeable batteries. There is a slight risk of cyclical switching the two between sources, but decoupling capacitors have been utilized to minimize the effect on the rest of the system. The voltage switch has a low operating current of  $55 \mu\text{A}$  and an ultra-low standby current of  $0.5 \mu\text{A}$ . The power source switch has a current limit of 1.25 A and a maximum voltage of 5.5 V. These values

are sufficiently high for powering all of the components of HHCSN except for the GSM modem. The GSM standard specifies that a GSM modem broadcast short pulse at 2 A for registration with the local cell tower. Since a single power circuitry cannot provide this high current, two power circuitries are required.

TI TPS61031 and TI TPS61032 boost converters are used to provide the desired voltages of 3.3 V and 5 V that power HHCSN. The 2 V switching threshold used earlier was selected in consideration of the boost converters, which require a minimum of 1.8 V. A buffer of 0.2 V was deemed a large enough. The output of the voltage source switch is fed into a 5 V boost converter and a 3.3 V boost converter, both of which have very low quiescent current of 20  $\mu\text{A}$  and a typical efficiency of 96%. With the ability to provide up to 1 A of current, constraints on the power circuitry are usually from the power source switch. Each boost converter has an enable line that allows the device to be turned off. The boost converters in this circuit are pulled high with an input line tied to the off-board connector. This configuration allows the device that is using this power circuitry to select one or both of the 3.3 V and 5 V lines, while turning off the unused source. When both boost converters are active, the current supplied at each voltage is limited to 625 mA. If one boost converter is deactivated, then up to 1 A can be pulled from the remaining boost converter.

Even though they seem relatively inconsequential, the connectors used to interface boards to each other actually affect the design. In the conceptual stage, connectors can be omitted. However, when planning the final design, the choice of connectors affects the amount of power that can be transmitted, the space occupied, the dependability of the device, and the effort required to utilize the connector. The C-GRID-3-70553 connector was chosen for board-to-board wire-based connections. This connector has a large footprint, allowing for easy installation, and a locking mechanism that increases the dependability of the device to which it is connected.

Two packs of batteries are connected to the power circuitry. Each set of batteries requires a minimum voltage of 3 V and a minimum current of 1.5 A. The minimum is 2 A because of the limits placed on the auto-switching power multiplexer and the boost converters. The rechargeable batteries used are NiMH. NiCad batteries are quite inexpensive and have a lifespan of up to 15 years; however, they are considered toxic and placing them in the soil would be illegal in certain countries. NiMH batteries



last 10 years and are slightly more expensive, but they can be placed in the soil without breaking any international regulations. Each battery pack is sealed in heat shrink and wrapped in insulation binding the batteries and protects them from rapid temperature changes.

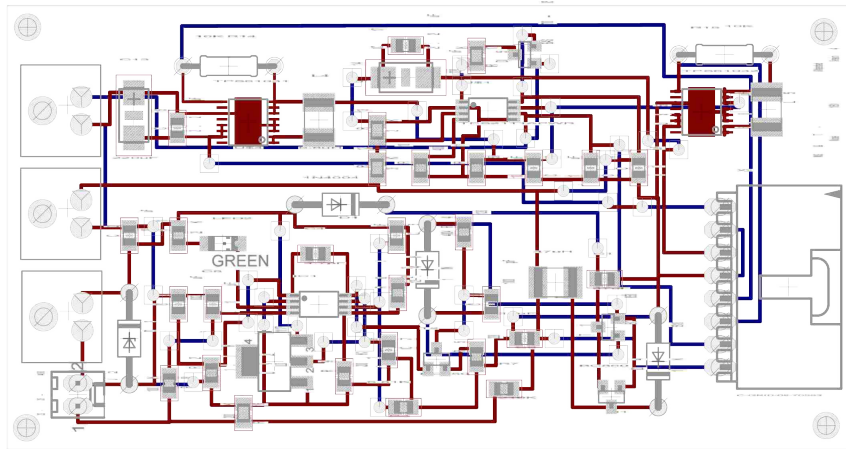

Figure 4.14. Schematic of the Power Circuitry

## 5 SOFTWARE ARCHITECTURE

The embedded and in situ nature of HHCSN necessitates dependable, real-time, compact code. The software developed for HHCSN was coded specifically to meet the needs of an expandable monitoring network designed with the objectives mentioned in Section 3. Sustainability and scalability are two of these objectives that particularly necessitate maintainability of the software. To this end, the software architecture was designed to be very simple, mitigates the troubleshooting and maintenance concerns associated with complex designs.

### 5.1 Network Creation

Communication among the devices in HHCSN follows the hierarchy described in Section 4. This requires that devices associate with each other to create ad-hoc clusters. Network creation begins with the CAPs, where each CAP has a 1:20 chance of being randomly selected to serve as a cluster head. As mentioned in Section 4, the recommendations of [34] were followed, where a cluster size of twenty nodes is experimentally shown to be most energy-efficient. The random selection of the cluster head in this fashion does not guarantee that each cluster will be formed of twenty nodes, but it is a simple and low-overhead way to create a network where  $\frac{1}{20}$  of the CAPs are cluster heads. Any CAP not designated as a cluster head is designated as a cluster node, and waits for the cluster head to connect to it. With respect to Figure 5.1, the cluster head would be designated as the sub-sink.

Each CAP begins a tree creation process once it has been designated as a cluster head. This is done by connecting to neighbors with the transmitting power level at its lowest. The transmitting power is incrementally increased until the CAP can no longer connect to a neighbor or it has reached the maximum power level. This power level is recorded and used for all future communication with its children. When one CAP has connected to another CAP, it waits for the newly connected node to reach the same power level of the parent CAP. When an unconnected CAP has a link created between it and another node, it begins a tree creation process of its own. This tree creation process is identical to that of the CAP that connected to it. The

end result of this process will result in a tree similar in form to the hierarchical tree seen in Figure 4.10 and Figure 5.1, with the cluster head being the sink and sub-sink, respectively.

After the clusters have been formed, the cluster heads begin a broadcast cycle. This broadcast cycle is to notify the base station and other cluster heads that this cluster is ready to be formed. When the base station hears a broadcast from a cluster head, it begins a tree forming process. The tree forming process is identical to the routine used to connect the nodes of the cluster to the cluster head. This should result in an end network in the form of Figure 5.1.

With cluster heads being randomly chosen, orphan clusters can be formed. It is the responsibility of the cluster head to realize that it cannot connect to another cluster head or base station. This is implemented by a timer on the cluster head. When the cluster head determines that the cluster is orphaned, it chooses a random CAP its the cluster to take over the responsibility of being a cluster head. If this newly chosen cluster head can connect to another cluster head, it begins the cluster formation process among itself and the other CAPs of the cluster. This cycle of randomly choosing a CAP to take over the responsibilities of being the cluster head continues until a CAP is found that can connect to the other cluster heads.

## 5.2 Base Station

The base station, as stated in Section 4, includes two controllers: the main microcontroller and the Zigbee microcontroller. The main microcontroller is responsible for GSM operation and overall control, while the Zigbee microcontroller is solely responsible for Zigbee communication. The control is divided in this fashion due to the immediate responsiveness required for handling Zigbee communication.

All of the Zigbee stacks evaluated, including the final choice of the TI Z-Stack, required that Zigbee operation take precedence over all other operations. Therefore, real-time operation of the GSM modem necessitated that the Zigbee operation be delegated to its own controller, which required that the main microcontroller instruct the Zigbee microcontroller to tasks that it should perform. However, the Zigbee controller is a fully fledged microcontroller; it can perform many of the required operations itself, without outside guidance. This independence means the main microcontroller only

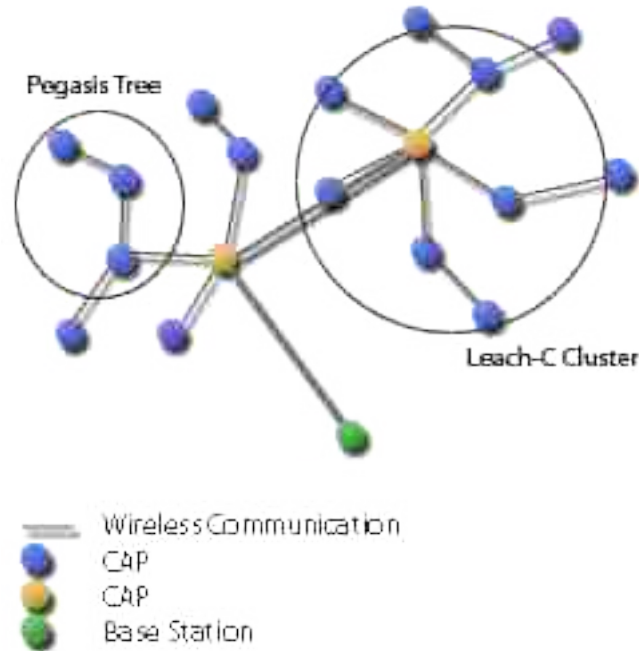

Figure 5.1. Network Organization

has to send the Zigbee controller the data and instructions. Thereafter, the Zigbee microcontroller handles all Zigbee network creation, maintenance, and transmission with little to no outside guidance.

**5.2.1 Main Microcontroller** The base station is required to act as the connection between the outside world and the sensing network. It must handle GSM communication, store data from the network, and serve as the coordinator node for the Zigbee network. The only time constraint placed on the base station is that it maintain a clock synchronized with the rest of the network.

The base station initialization procedure is depicted in Figure 5.2. The first step is to create a temporary connection to the remote server. Once the base station ensures that it is possible to connect to the remote server, it requests from the server any updates that it is to perform on itself or disseminate to the rest of the network. It should be noted that these updates can also be uploaded to the base station through the internal USB port.

The main microcontroller instructs the Zigbee microcontroller to begin network creation. The Zigbee controller then informs the main microcontroller of the success

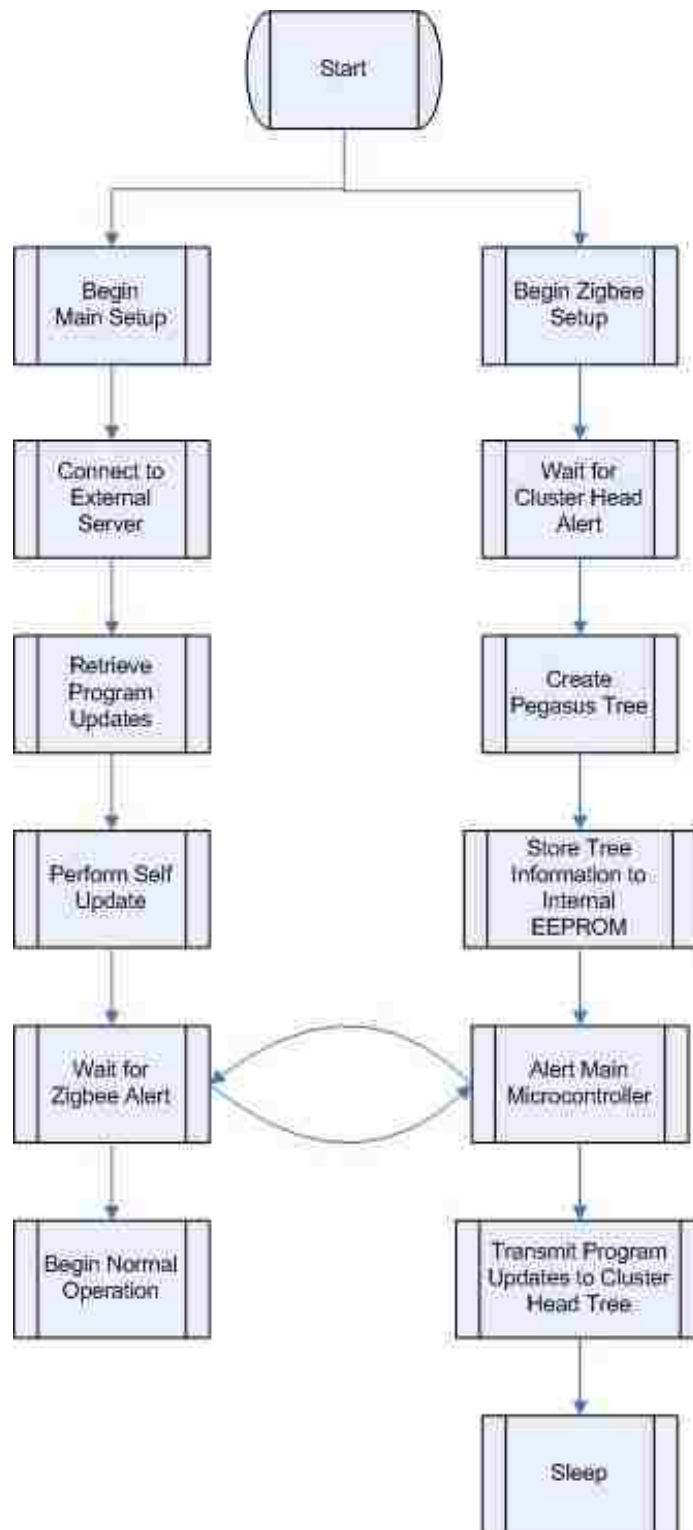

Figure 5.2. Flow Chart of Base Station Setup

or failure of this task, and any errors. If network creation fails, the remote server is informed and the base station goes into a temporary deep sleep. The base station will periodically wake up from this deep sleep, reattempt the network creation process, and inform the remote server of the status of each attempt. The purpose of the reattempt is for cases in which the base station is initially placed in a network, but the rest of the network has not yet been deployed. If an error occurs, but a network is still formed, the base station informs the remote server and continues normal operation.

Once the base station has connected to the remote server and attempted network creation, it sends the Zigbee microcontroller any update information it has obtained from the remote server and responds to error conditions as previously described. If a network has been successfully created and updated, then the base station begins normal operation cycle.

With the use of a bootloader, if the software update fails, the previous operating software will be written back to the program memory. This rollback and recovery ensures dependable operation.

**5.2.2 Zigbee Microcontroller** The Zigbee microcontroller is responsible for managing the Zigbee network, and eliminates the burden of associated tasks from the main microcontroller. It handles all transmission and reception, as well as network maintenance and control.

Once the Zigbee microcontroller has been awakened and given setup instructions, it creates a network using the routine mentioned earlier in Section 5.1.

When one or more nodes respond with an acknowledgement, the base station stores their identification information in its internal EEPROM and goes into a soft sleep mode, where it waits for a period of time for the node(s) to perform a similar action until the node(s) are at the same power level. This waiting period allows for the tree network to be created with each node transmitting at the lowest possible level while creating a connection to each cluster head.

Once the base station has created the network, it records in memory the minimum power level required to connect to every direct child. The base station then transmits to its children any information it has obtained from the remote server that pertains to the rest of the network, such as schedule updates. The base station starts a timer and waits for acknowledgement from the children, indicating that the update

has been performed successfully. If the timer of the base station expires before it receives acknowledgement from a child, it informs the main microcontroller of the loss of connection to the child. The base station then removes that child from its list of children to prevent it from waiting for a node that may no longer be operational.

If the base station completes this child search algorithm without finding a single child, it informs the main microcontroller, which then takes appropriate action. It should be noted, however, that this case is highly unlikely due to the fact that the base station only begins this process once it has received a “ready” message from at least one cluster head node. If this case occurs, the base station will take action as instructed by the main microcontroller.

The normal operation of the Zigbee microcontroller is quite simple. The Zigbee microcontroller is normally in a deep sleep mode, in which it uses very little power. It is awakened from this state by the main microcontroller. Awakening usually occurs when the main microcontroller has scheduled a network send/receive operation.

When the Zigbee node acts as a router, it does not inform the main microcontroller that sending/receiving is being performed. When the Zigbee microcontroller has received data, it raises an interrupt on the main microcontroller to inform it that data has arrived and is waiting for it on the Zigbee microcontroller. This notification is carried out only when the received data is pertinent to the main microcontroller. When the main microcontroller has data for the Zigbee microcontroller to send, it sends a command along the SPI bus to the Zigbee microcontroller. The main microcontroller then sends the data to the Zigbee microcontroller, which in turn will forward it to its parent node.

Every time a network-wide Zigbee operation is performed, the Zigbee microcontroller increments an internal counter. This counter is used to indicate when the Zigbee network will be recreated using the setup process described earlier in this section. As with the main microcontroller, a bootloader is implemented to ensure that if a software update fails the previous software can be run.

For reference purposes, the Z-Stack version used for this project is 1.4.3.

### 5.3 Communication Access Point

In a manner similar to the base station, the CAP includes two controllers: a main microcontroller and a Zigbee microcontroller. The main microcontroller is responsible for sensor string operation and overall control, while the Zigbee microcontroller is solely responsible for Zigbee communication. As in the base station, tasks are divided in this fashion because of the immediate responsiveness required for Zigbee communication.

Due to time constraints, a real-time operating system was not developed for the main microcontroller, as planned. Therefore, the main microcontroller of the CAP runs a series of operations that require reprogramming to be altered. The Zigbee microcontroller is programmed with the Z-Stack to allow for easy routing and connection control. The Z-Stack has a real-time operating system as part of its code. Even though real-time operation was not the intent of using the Z-Stack, it does provide some real-time functionality. The Z-Stack was chosen as a result of its ease of use, documentation, and support for the cc2430.

The program flow for initialization of the CAP is shown in Figure 5.3.

**5.3.1 Main Microcontroller** The setup process for the main microcontroller of the CAP is fairly simple, because the creation and management of Zigbee network are delegated to the Zigbee microcontroller. The main microcontroller ensures that the Zigbee controller is awake and instructs it to begin its setup process. While the Zigbee controller is handling the creation of the Zigbee network, the main microcontroller begins setup of the CAN network.

A message is sent to the CAN address of the each sensor node on the string of the CAP. The message requests that the sensor node respond with its hardware identification information. Upon receipt of each response, the CAP stores the identification information of the corresponding sensor node in the external EEPROM and records the CAN address and dynamic identification designated by the CAP of the node in its internal EEPROM.

The main microcontroller then waits for the Zigbee microcontroller to inform it of any software updates to be sent to the sensor nodes. If there are no updates, the



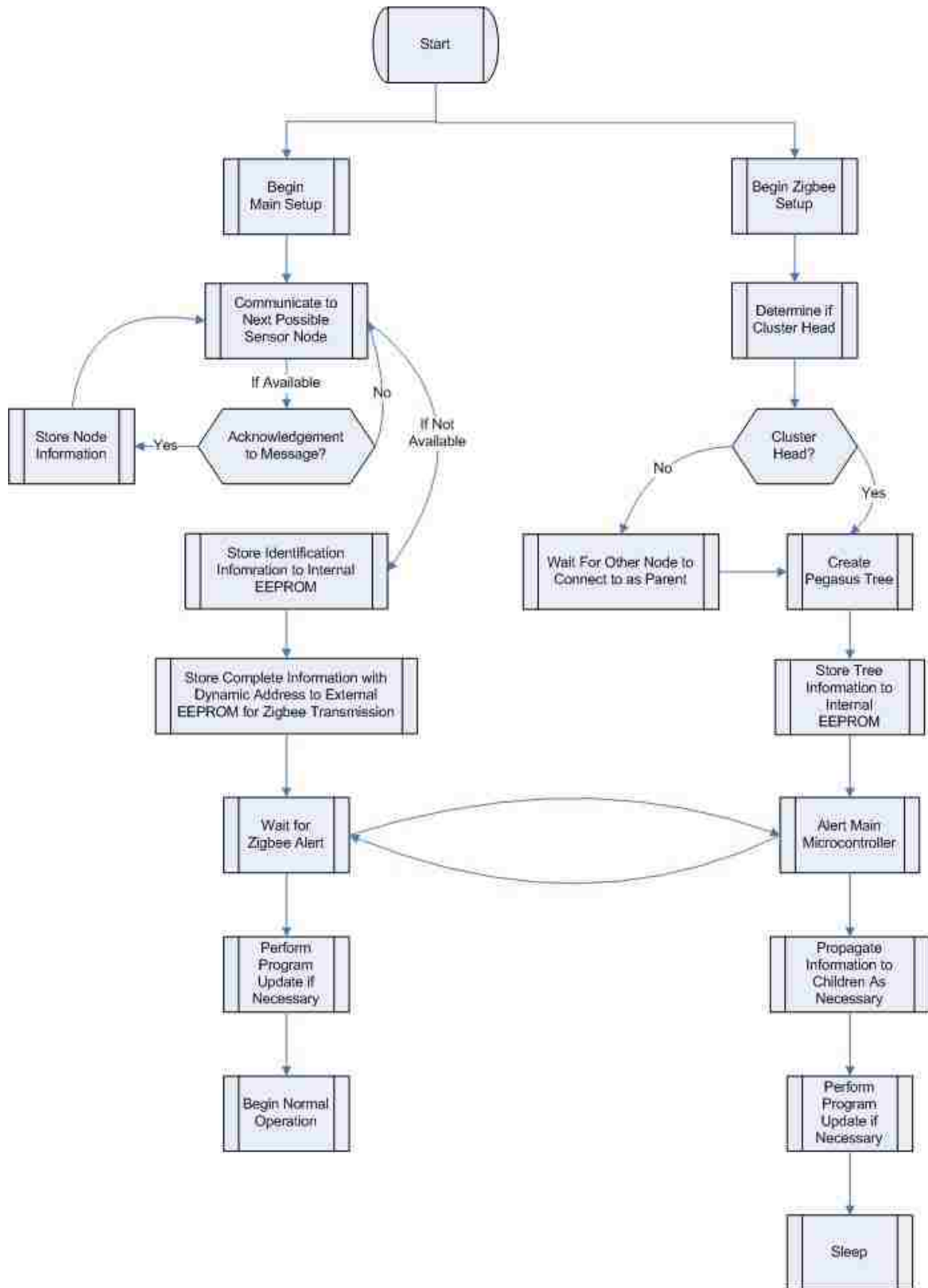

Figure 5.3. Flow Chart of Communication Access Point Setup

main microcontroller tells the Zigbee microcontroller to sleep upon completion of its remaining tasks. If a software update is indicated, the main microcontroller awakens the sensing string, broadcasts the updates to all the sensing nodes on the string, and waits for their acknowledgement of successful receipt and status of the execution of the program update. Subsequently, the main microcontroller carries out any software updates intended for itself, and notifies the Zigbee microcontroller of the outcome of the update. It then instructs the Zigbee microcontroller to sleep upon completion of its remaining tasks. The main microcontroller then begins its operation.

Operation of the main microcontroller begins once the microcontroller is awakened from the watchdog timer set at the end of the setup phase or the end of the previous operation cycle. The watchdog timer allows the microcontroller to be awakened out of a deep sleep when the timer completes. With the use of a bootloader, if the software update fails the previous operating software will be written back to the program memory. Thus, even if a software update fails, the previous program will be used.

**5.3.2 Zigbee Microcontroller** As described in Section 5.3.1, the Zigbee microcontroller is awakened by the main microcontroller, and notified of the task it should perform. Once instructed to begin the setup process, it begins the network (re)creation process mentioned earlier.

It should be noted that during the cluster tree formation process, communication information is passed between a parent of the tree and the child to which it most recently connected. Included in this information is the power level that the parent needed to connect with the child. This is useful to the child, because it now knows an expected power level necessary to communicate with its parent.

After the network has been performed using the network creation process mentioned earlier, the CAPs transmit hardware identification and dynamic addresses through the network, to the base station and ultimately the end remote server. This is done so future communication can be performed using dynamic addressing and the remote server can perform address mapping. Once the network has been created, a node only forwards packets from CAPs designated as its parent or its child with respect to the tree structure. This is done to limit redundant packets traveling through the network.

Once the network has been successfully formed, each child indicates to its parent that it is ready for software updates. If software updates are received from its parent, they are repeated to the children of the CAP and disseminated to the main microcontroller of the CAP. The Zigbee microcontroller then waits for acknowledgement of the update status from its children and its main microcontroller before starting the update on itself. Once that process is completed, the device on which it is running informs its parent of successful completion.

After the Zigbee microcontroller has completed all current tasks, it waits for the main microcontroller to inform it that the Zigbee microcontroller can now sleep. Once that message has been received, the Zigbee microcontroller goes into a deep sleep.

The normal operation of the Zigbee microcontroller is quite simple with respect to the setup process. The Zigbee microcontroller is normally in a deep sleep mode in which it uses very little power. It is awakened from this state by the main microcontroller, usually when the main microcontroller has a scheduled network send/receive operation.

When the Zigbee node acts as a router, it does not inform the main microcontroller that sending/receiving is being performed. When the Zigbee microcontroller has received data pertinent to the main microcontroller, it raises an interrupt on the main microcontroller to inform it that data has arrived and is waiting for it on the Zigbee microcontroller. When the main microcontroller has some data for the Zigbee microcontroller to send, it sends a command along the SPI bus to the Zigbee microcontroller. The main microcontroller then sends the data for the Zigbee microcontroller to forward to its parent node.

When transmitting sensor data along the network to the remote server, the Zigbee microcontroller sends all information from its children before sending its own data. This action allows the parent to have a sense of whether further data is expected.

As with the base station, every time a network-wide Zigbee operation is performed, the Zigbee microcontroller increments a counter to indicate when the Zigbee network will be reformed using the setup process described above. As with the main

microcontroller, a bootloader is implemented to ensure that if a software update fails the previous software can be recovered and executed.

#### 5.4 Sensor Node

The sensor node is the entity responsible for carrying out all sensing operations, as instructed by the corresponding CAP. The software for the sensor node was designed to be very lightweight, as it acts purely in a reactionary fashion. The setup program flow for setup of the sensor node is shown in Figure 5.4.

The sensor node is kept in sleep mode whenever it is not actively sensing. The CAP sends an interrupt on the sensor string bus to wake the sensing nodes as needed. Once awakened, a sensor node waits to receive a message from the CAP. The message will contain the address of the CAP, and requests the hardware identification information of the sensor node. The sensor node records the received CAP address in its internal EEPROM for later reference. Hereafter, the sensor node will only respond to messages broadcast to all sensor nodes, to messages sent directly to it from the CAP, and to messages sent from a sensor node on the same string, that has been designated by the CAP as its partner for measurement of resistivity. The sensor node waits a short period of time to receive such messages, and then reenters a deep sleep to save power.

In summary, the sensor node is awakened when the CAP node drives a high signal on the string bus, triggering an interrupt. The CAP node then sends a command to the sensor node. This command can be to perform a specific sensing operation, form a pair with another sensor for resistivity measurement, send identification information, or perform a group of sensing operations.

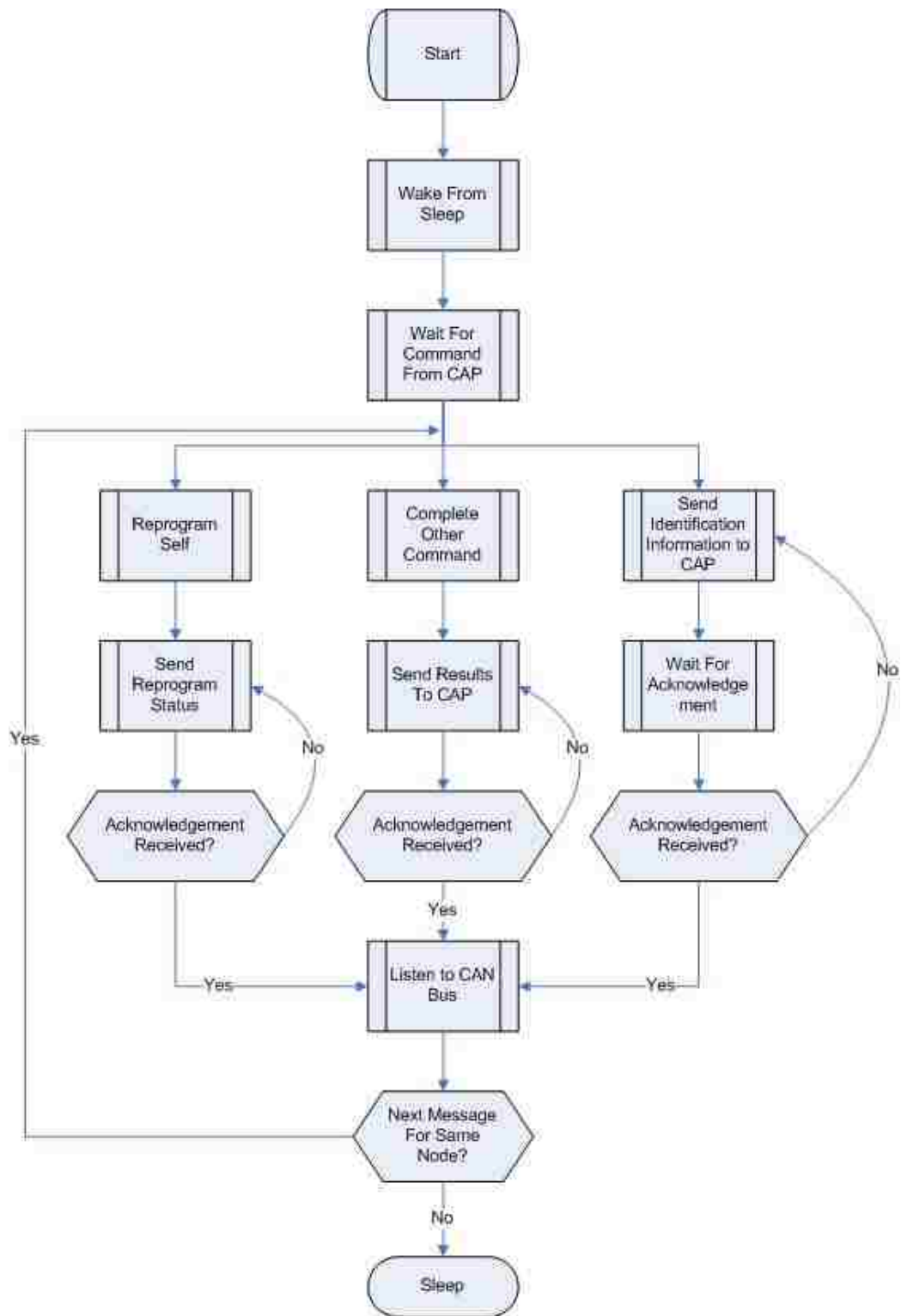

Figure 5.4. Flow Chart of Sensor Node Setup

## 6 PROJECT STATUS AND EVALUATION

As described in Section 3, the goals of this project were to provide a cost-efficient, accurate, and sustainable watershed monitoring network. This section quantitatively demonstrates that these objectives have been achieved.

### 6.1 System Status

At time of publication, development of the HHCSN was partially complete. A prototype of the sensor node was developed and validated with laboratory testing. As described in Section 2, a prototype of the TDT sensor was designed and implemented as a senior design project. Laboratory testing of the TDT sensor validated its correct operation. The TDR sensor to be used in HHCSN is nearly identical to this TDT, but at time of publication, the TDR had not yet been implemented. A prototype of the resistivity sensor was developed and validated by laboratory testing. Field testing of all sensors was yet to be performed. Implementation of a full sensor node was planned to follow field testing of all components.

The CAP in use was a second-generation production model, which was developed to address minor hardware issues and to incorporate elements that would facilitate troubleshooting. This second-generation prototype was laboratory tested to ensure correct operation of a subset of the features, in particular microcontroller programming and operation. Full laboratory and field testing of all features, including the Zigbee and CAN communication was planned for the immediate future.

The base station was designed, but was yet to be implemented. This device is the most costly of the main parts of the system, and its implementation was left to final stages of the project.

All CAPs and base stations share the common power circuitry described in Section 4. This hardware was implemented and tested separately, and as part of the CAP.

## 6.2 Cost

The sensor node has 40 components, including the probes and printed circuit board (PCB). The most significant contributor to the cost of the system is the PCB, which in prototyping scales is more than twice the cost of the remaining components. The prototyping cost of a PCB board is \$33. In production scales, the cost of the PCB drops to \$6.53 for 50, \$3.25 for 150, and \$2.60 for more than 250 units. The cost of the remaining 39 components in prototyping quantities is \$17.32. For production quantities, this value is expected to drop to approximately \$12 per unit. This price is very reasonable considering that current monitoring tools, e.g., TDR, TDT, resistivity sensors, cost hundreds of dollars each, while our sensor node performs TDT, TDR, resistivity, and temperature monitoring for only \$12 per unit.

The CAP has 33 components, including the probes and PCB. Again, the PCB is responsible for most of the cost in prototyping scales. In production, the PCB cost drops to \$6.33 for 50, \$3.06 for 150, and \$2.40 for more than 250. The cost of the remaining 32 components in prototyping quantities is \$15.67. For production quantities, this value is expected to drop to approximately \$10 per unit.

The base station has 34 components, including the probes and PCB. The main cost of the base station is the required GSM modem. Since production scales for this device will rarely be achieved, the cost of the device is expected to remain around \$160 per unit. After the GSM modem, the majority of the prototyping cost is due to the PCB, which is more than twice the cost of production scales.

The power circuitry has 51 components, including the probes and PCB. As before, the majority of the cost is due to the PCB. In production scales the cost of the PCB drops to \$6.34 for 50, \$3.10 for 150, and \$2.45 for 250. The cost of the remaining 50 components in prototyping quantities is \$23.78. The price drops to approximately \$15 per unit for production scales. A synopsis of the total costs of each device can be seen in Table 6.1.

The overall cost of the HHCSN system, for one base station, 100 CAPs, and 10 sensor nodes per CAP, is \$3,860 in production. A system of this size can cover an area of 50 m<sup>2</sup>, to a depth of .1 m. The cost of an existing alternative that monitors

Table 6.1. Cost Analysis

	Cost Per Unit In Prototyping	Cost Per Unit In Production
Sensor Node	\$50.32	\$12.00
CAP	\$48.67	\$10.00
Base Station	\$160.00	\$160.00
Power Circuitry	\$56.78	\$15.00
Total	\$315.77	\$197.00

only soil moisture, such as a data logger, for the same area, would be three times as much. The accuracy and resolution of the data from HHCSN is significantly higher, at a fraction of the cost.

### 6.3 Power Consumption

One of the main goals of HHCSN is to provide long-term sustainable watershed monitoring. This objective has been met with power harvesting, sleep cycles, and other aggressive power saving features.

The sensor node requires an estimated 3  $\mu$ Ah of energy per hour. This low rate is achieved by maintaining the majority of its components in a sleep state for as long as possible. An item-by-item breakdown of the energy cost can be seen in Table 6.2. This table breaks down the power cost with respect to each device and its operation. As seen in Table 6.2, communication is by far the most energy-consuming task.

Table 6.2. Power Analysis: Sensor Node

Item (Action)	Single Cost (Amp)	Times/Day (sec)	Cost/5 Yrs (Amp*hrs)
Main $\mu$ C - Sleep	0.000002	86399.5	0.0876
Main $\mu$ C - Full	0.001025	0.5	0.003
CAN - Sleep	0.000000	86399.83	7.8840
CAN - Tx/Rx	0.042000	0.17	13.3371
Temperature	0.0001	0.5	0.0000
TDT	0.001	0.5	0.0003
Total	0.04415		0.0904



The CAP uses an estimated 5  $\mu\text{Ah}$  of energy per hour, less than the total required listed below, due to aggressive sleep cycles and minimal wireless communication. As seen in Table 6.3, the most energy-consuming task, is once again a running theme for costs within the network.

Table 6.3. Power Analysis: Communication Access Point

Item (Action)	Single Cost (Amp)	Times/Day (sec)	Cost/5 Yrs (Amp*hrs)
Main $\mu\text{C}$ - Sleep	0.000002	86348.67	0.0875
Main $\mu\text{C}$ - Full	0.001025	51.33	0.0267
CAN - Sleep	0.000000	86399.83	0.002
CAN - Tx/Rx	0.042000	0.17	0.0037
Zigbee - Tx	0.027	0.00	0.0000
Zigbee - Rx	0.027	0.00	0.0000
Zigbee - Sleep	0.0000002	86400.00	0.0088
Total	0.097027		0.1321

The base station uses an estimated 120  $\mu\text{Ah}$  of energy per hour by minimizing wireless communication. However, this estimate is expected to increase in real-world deployments, due to variations in the length of time the device will be required to remain in an active state during wireless communication, as the network is expandable. The base station has similar power consumption to the CAP and sensor nodes. Table 6.4 shows that communication demands the most energy, which is one reason for removing any other responsibilities from the base station.

The power circuitry consumes power of its own in boosting the voltages up to the desired levels and automatically switching between the two battery sources. As shown in Table 6.5, the energy required is small, but does add up over time.

The total per hour energy consumption is shown in Table 6.6. This table illustrates that the solar panel will produce more energy than is expected to be consumed by the network. With a network of one base station, 100 CAPs, and 100 sensor nodes per CAP, the network can last two years on 2 A, 5 V battery packs without recharging. A total of 101 battery packs would be required for this setup since each CAP and each base station requires an individual battery pack.

Table 6.4. Power Analysis: Base Station

Item (Action)	Single Cost (Amp)	Times/Day (sec)	Cost/5 Yrs (Amp*hrs)
Main $\mu$ C - Sleep	0.000002	86397.19	0.0876
Main $\mu$ C - Full	0.001025	2.81	0.0015
Zigbee - Tx	0.027	0.00	0.0000
Zigbee - Rx	0.027	0.00	0.0000
Zigbee - Sleep	0.0000002	86400.00	0.0088
GSM Module	0.44	0.2	0.0439
GSM Module	0.44	0.3	0.0677
GSM Module	0.0001	86399.5	4.818
Total	0.9352		5.027

Table 6.5. Power Analysis: Power Circuitry

Item (Action)	Single Cost (Amp)	Times/Day (sec)	Cost/5 Yrs (Amp*hrs)
Boost Converters	0.00005	86400	2.19
Source Switch	0.000001	86400	0.04
Total	0.000051		2.23

Table 6.6. Power Consumption

	Amperage Consumed	Amperage Produced
Sensor Node	$3\mu$ A	0
CAP	$5\mu$ A	0
Base Station	$120\mu$ A	0
Power	$10\mu$ A	100mA (at 100% sunlight)

## 6.4 Accuracy of Measurements

Currently the sensors for HHCSN have only been tested in laboratory settings. Thus the results provide a best-case scenario and do not reflect real-world circumstances. The accuracy for the resistivity measurement decreases logarithmically as the resistivity increases. This is due to the 12-bit A/D converter and the operation used

to determine the resistance. As a result of the TDT and TDR measurement consisting mainly of delay measurement, the accuracy remains static, unlike the resistivity measurement.

Table 6.7. Nominal Accuracy of Measurements

	Accuracy	Range
Temperature	$\pm 1^{\circ}\text{C}$	$-55^{\circ}\text{C}$ to $+127^{\circ}\text{C}$
TDT	12-bit	90 psecs to 368.64 nsecs
TDR	12-bit	90 psecs to 368.64 nsecs
Resistivity	$\pm 0.01\Omega$	$5\Omega$ to $20,000\Omega$

## 7 CONCLUSIONS AND FUTURE WORK

This thesis describes the objectives, approach, and capabilities of the HHCSN watershed monitoring system. This system incorporates wired and wireless communication, is autonomous, uses only battery power, performs solar harvesting, and uses the GSM mobile phone network to allow for remote data collection, system configuration, and software update. The solar harvesting and battery-based energy storage allow for long-term operation without an external power source. Concurrent measurement at several points across the area and below the surface enables accurate analysis of the soil properties.

While the majority of the system has been implemented and tested in the laboratory, implementation of the base station, integration of the various components of the sensor node, and laboratory and field testing of the complete system remain to be completed. Pending enhancements include implementing a real-time operating system on the CAP and base station, adding more sensors to each sensor node, and reducing the power consumption of existing sensors. The added benefit of the real-time operating system is that it allows the network to respond to events and provide more dynamic execution of tasks. While the sensors currently on the sensor node are able to provide a good understanding of the soil properties, measurement of additional attributes will further this understanding. HHCSN is designed to interact with a remote server for software updates, as well as transmitting the data gathered from the sensors of the network. This remote server is yet to be developed.

The cost reduction, sustainability, and monitoring capabilities of the HHCSN system have the potential to expand monitoring of hydro-geological environments to meet the growing need foreseen by international organizations such as NEON and CUAHSI. This improvement will allow for greater understanding of watersheds, which enables more effective interaction with the environment, improves environmental predictions, and can lead to better overall land use practices. The general design of the network facilitates application to alternative domains. Its low cost and adaptability will facilitate deployment in a broad range of locations, and the data collected from these diverse environments will be instrumental to advances in hydrological sciences.

APPENDIX A  
BASE STATION

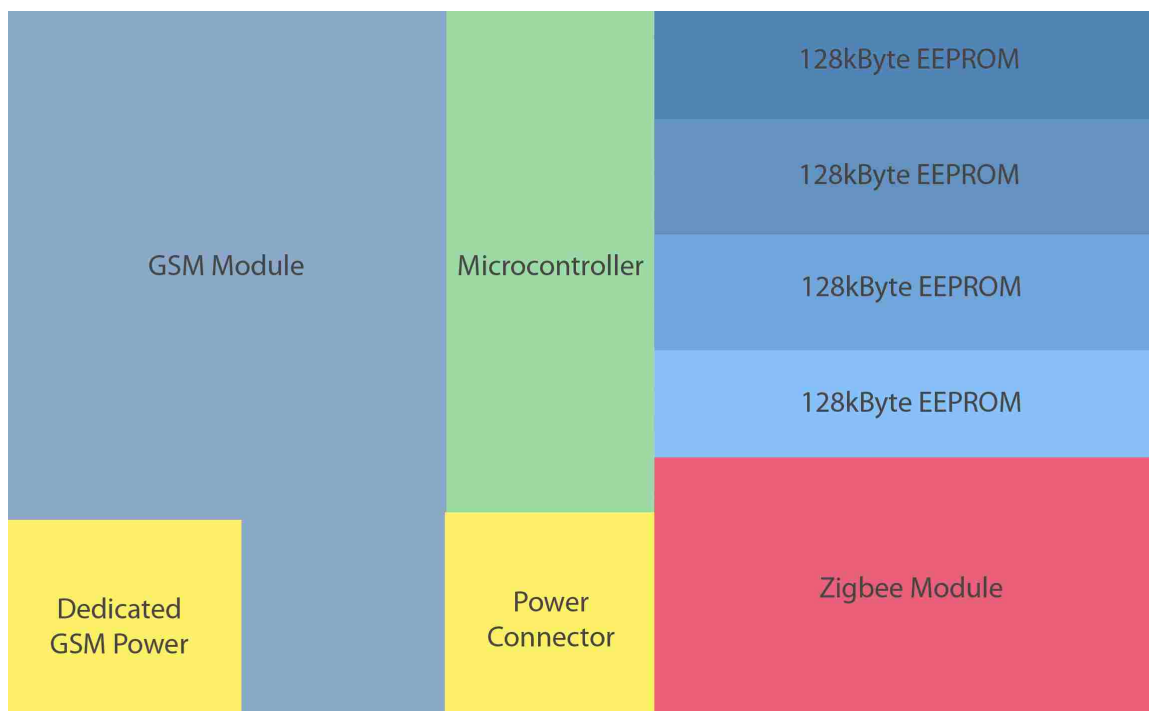

Figure A.1. Layout of the Base Station (Large)

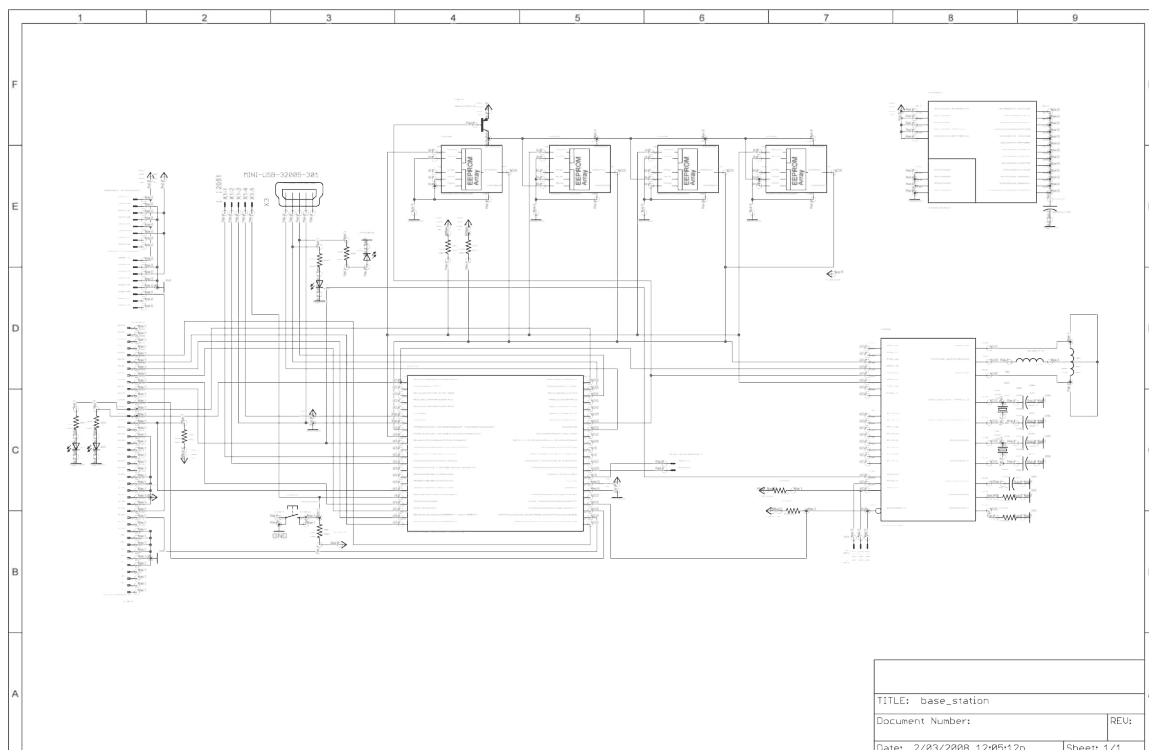

Figure A.2. Schematic of the Base Station (Large)

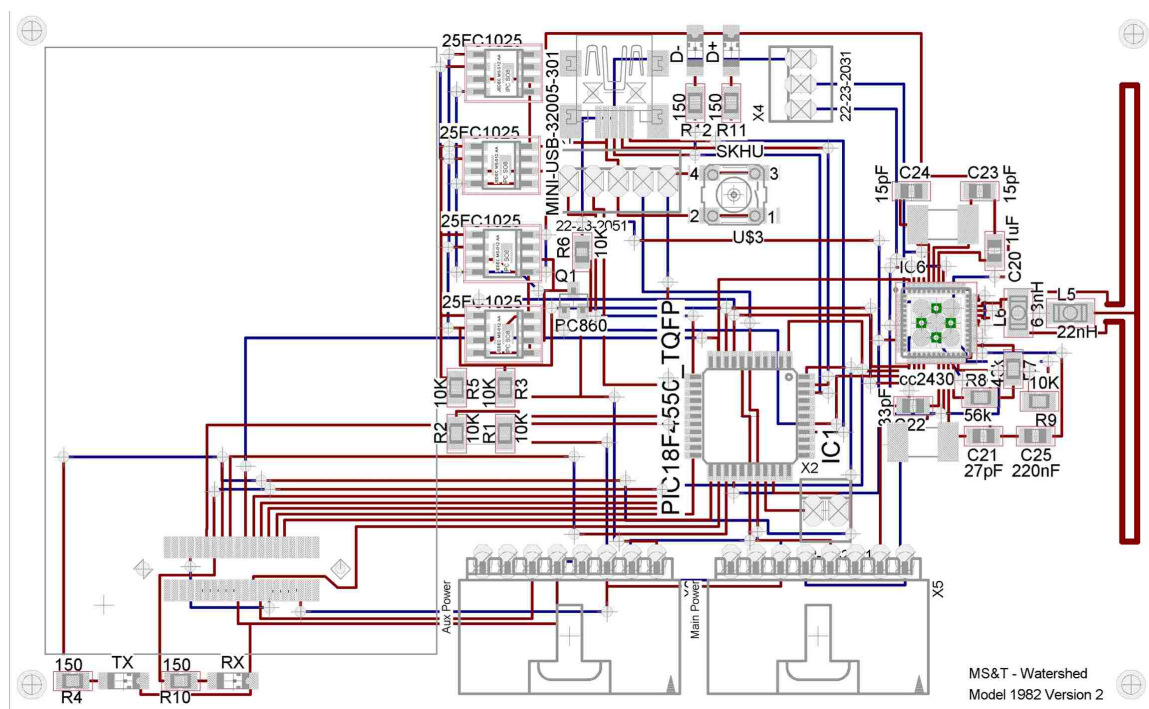

Figure A.3. PCB of the Base Station (Large)

APPENDIX B

COMMUNICATION ACCESS POINT



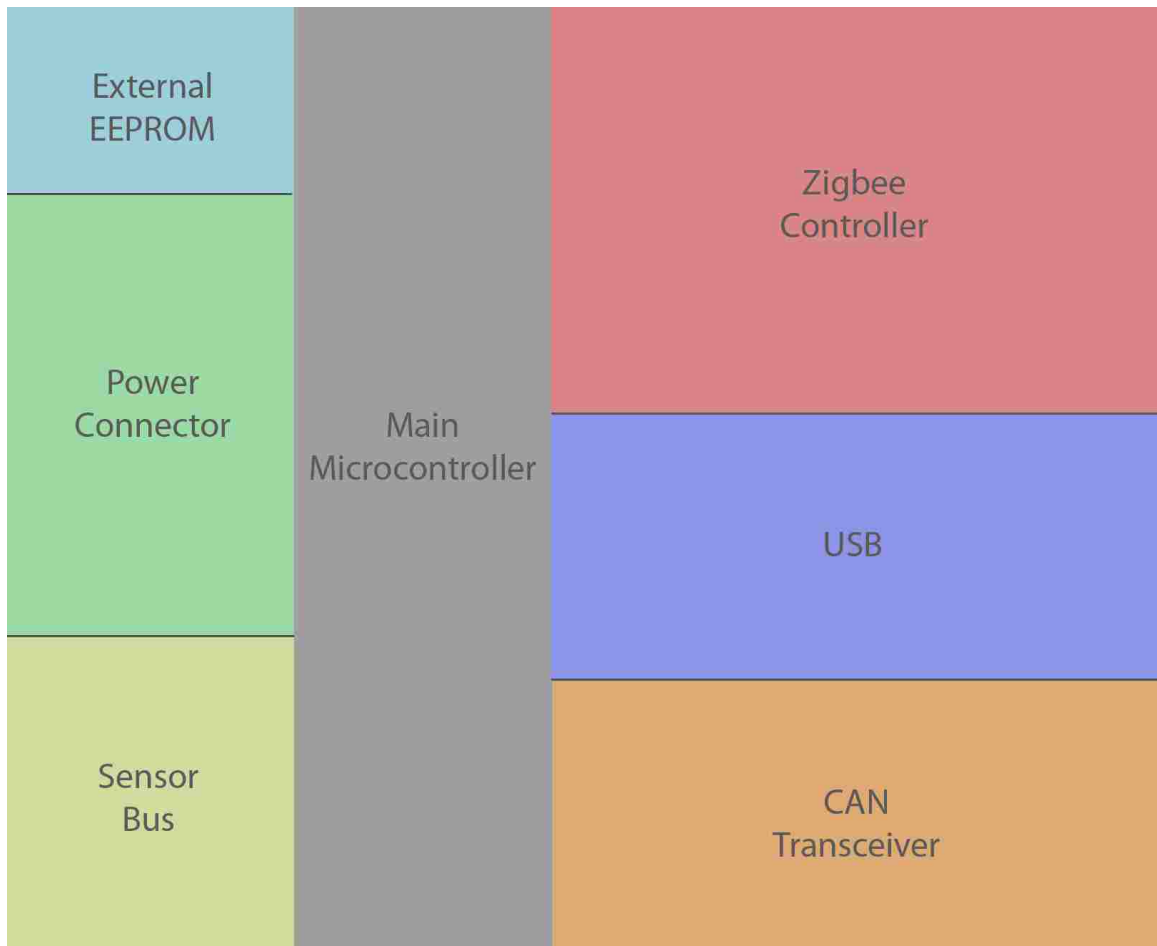

Figure B.1. Layout of the Communication Access Point (Large)

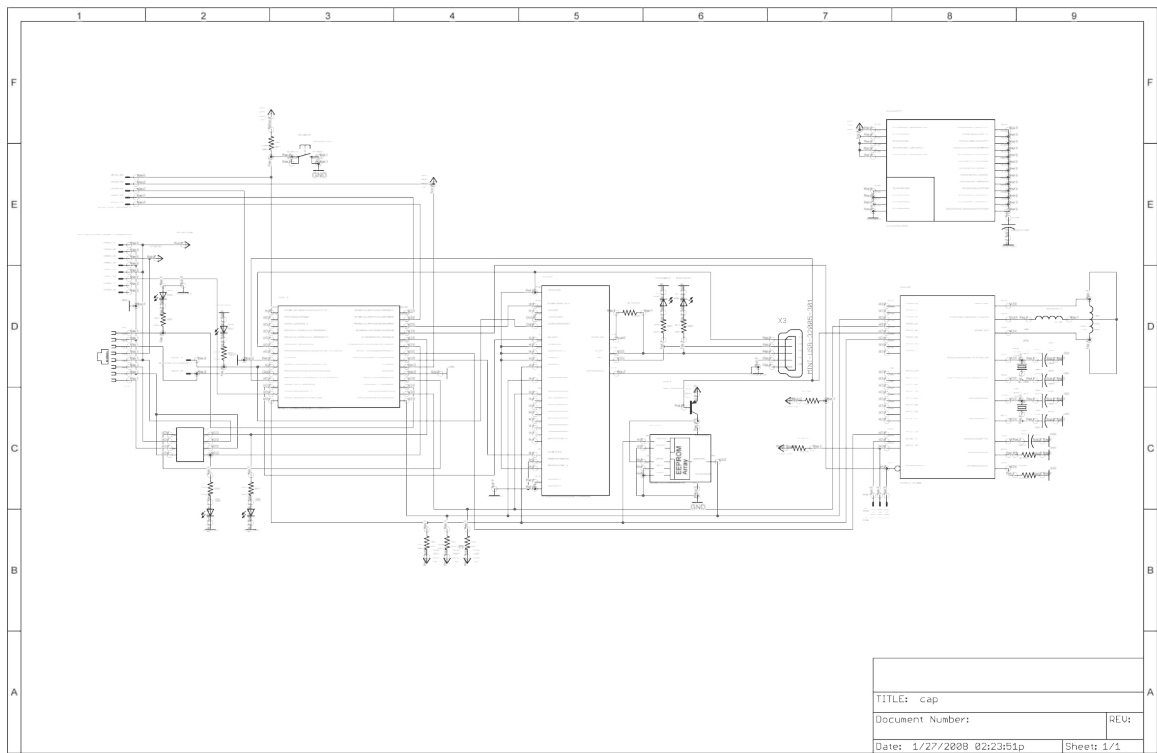

Figure B.2. Schematic of the Communication Access Point (Large)

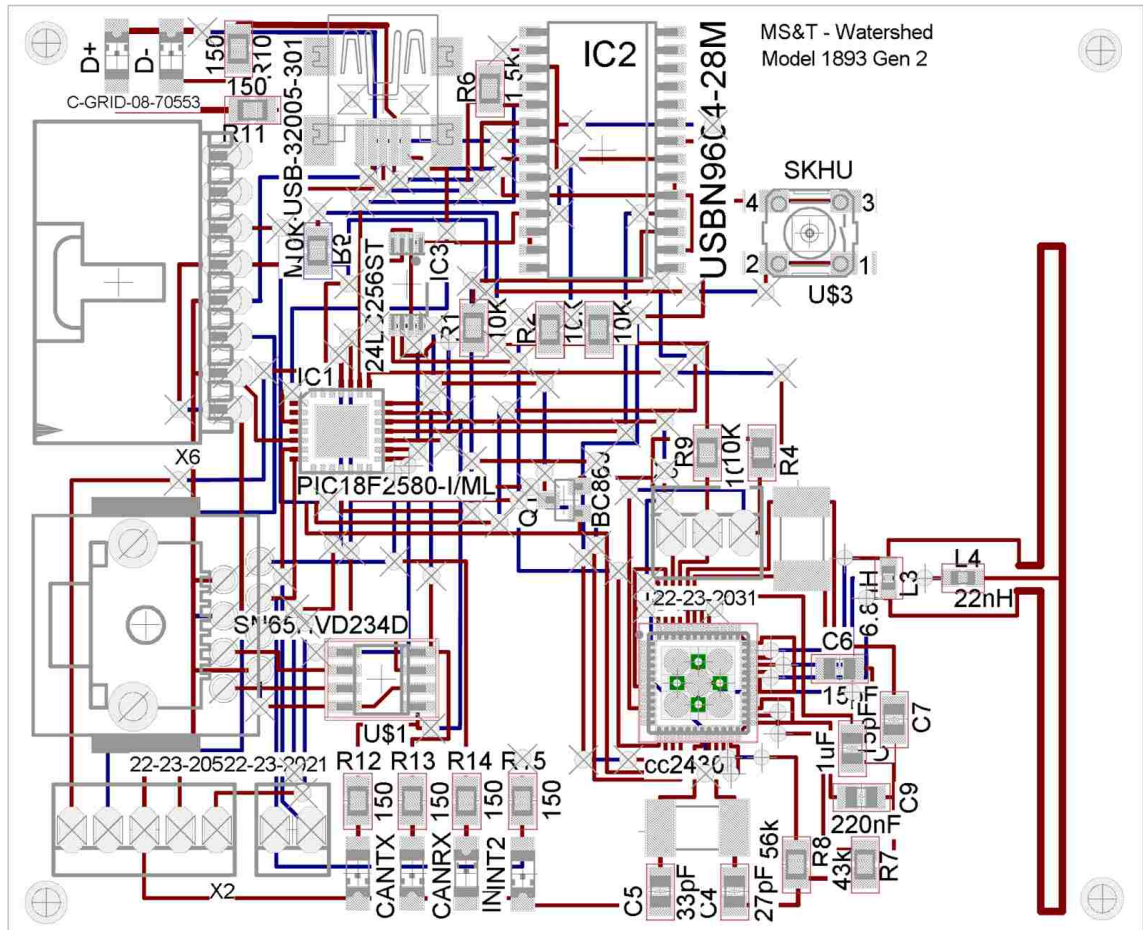

Figure B.3. PCB of the Communication Access Point (Large)

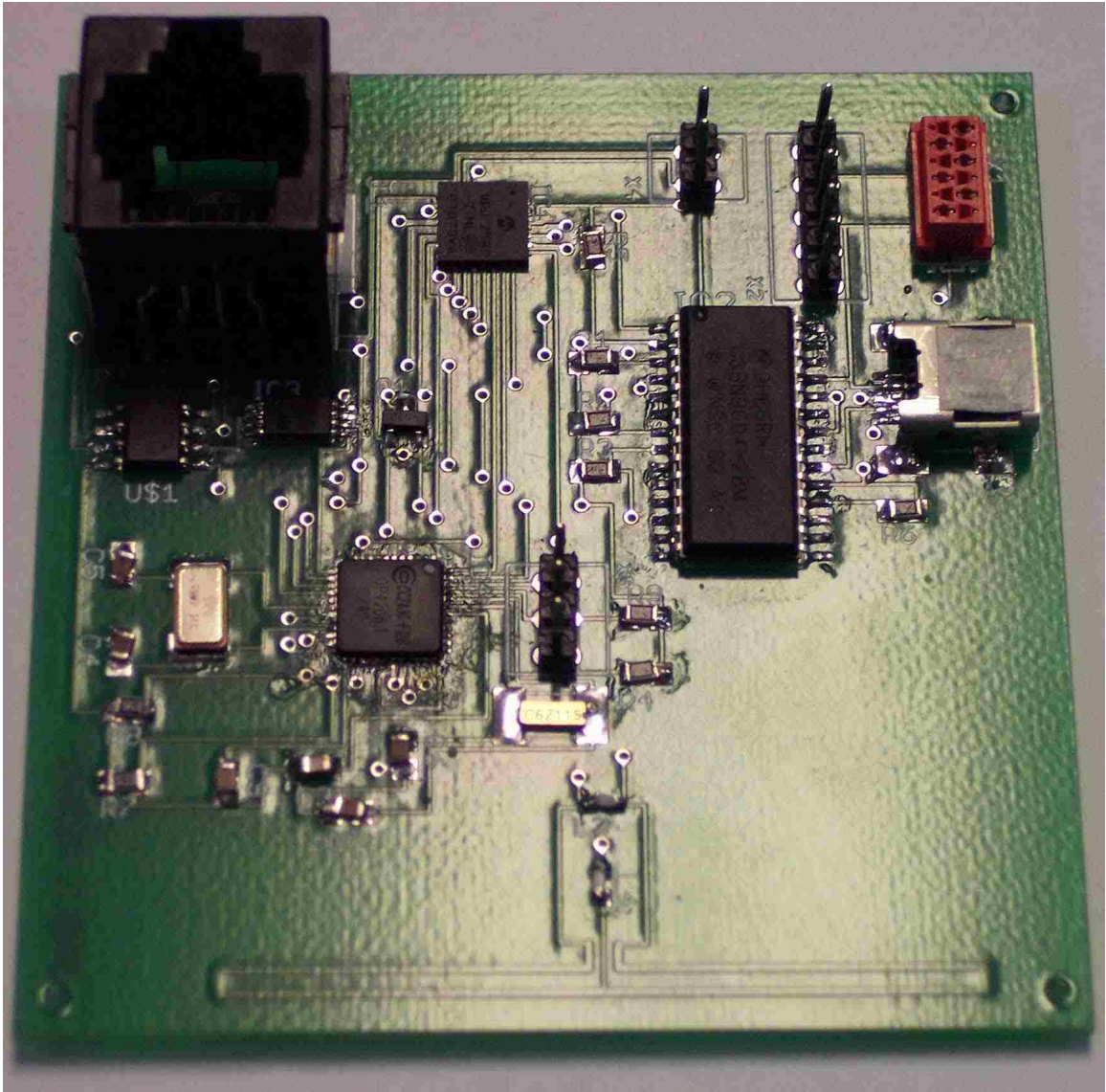

Figure B.4. Prototype of the Communication Access Point (Large)

APPENDIX C  
POWER CIRCUITRY

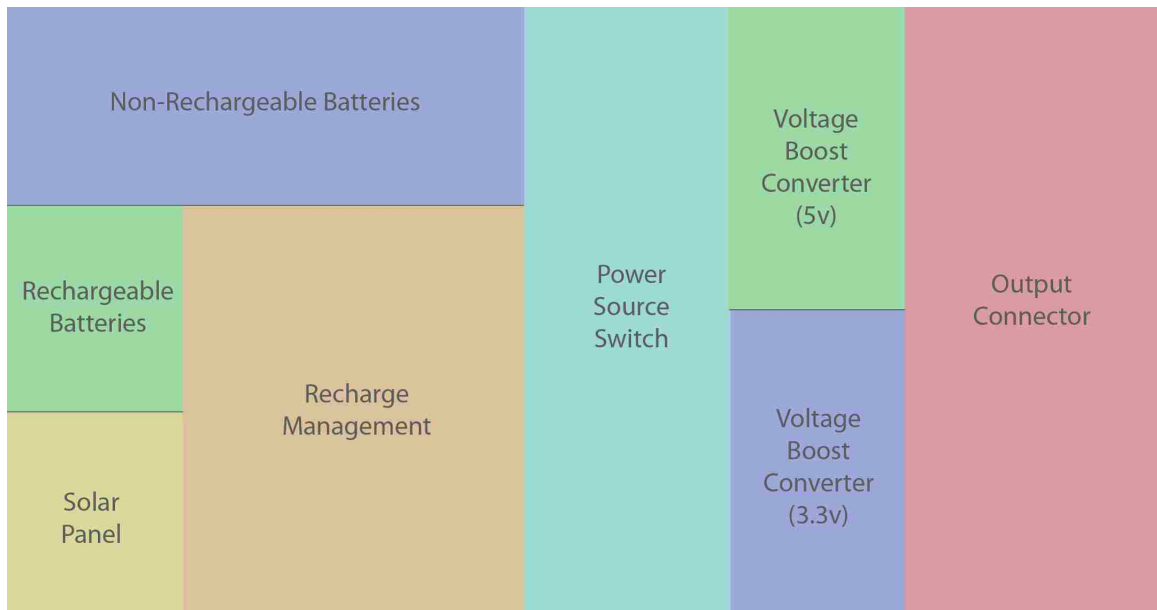

Figure C.1. Layout of the Power Circuitry (Large)

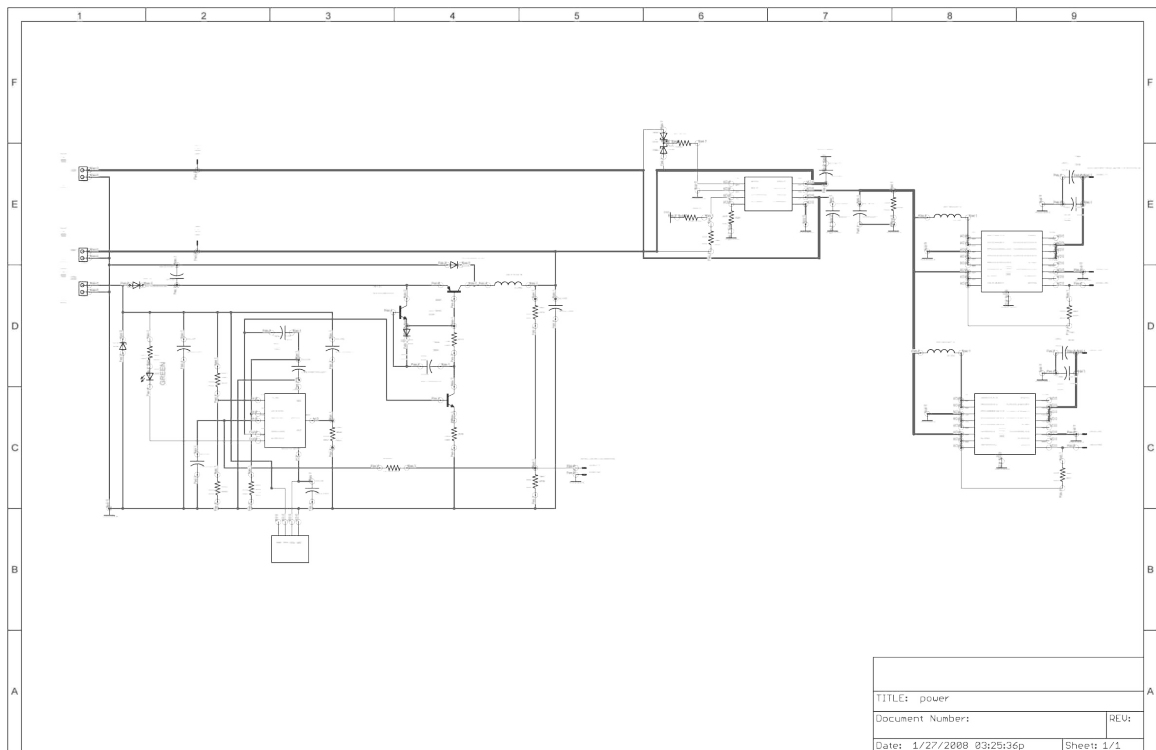

Figure C.2. Schematic of the Power Circuitry (Large)

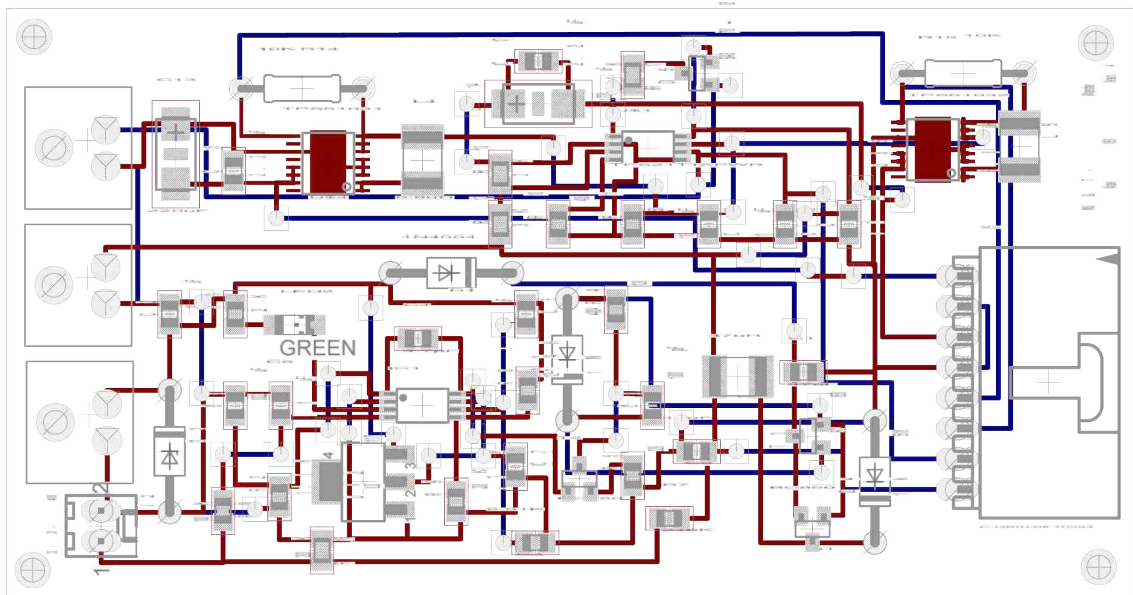

Figure C.3. PCB of the Power Circuitry (Large)

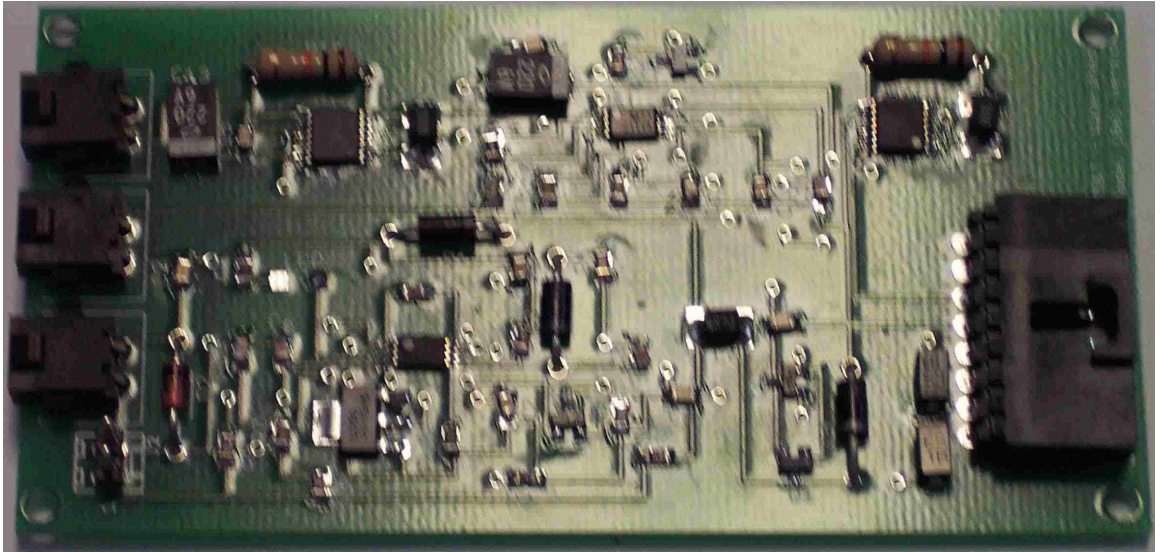

Figure C.4. Prototype of the Power Circuitry (Large)



APPENDIX D  
SENSOR NODE

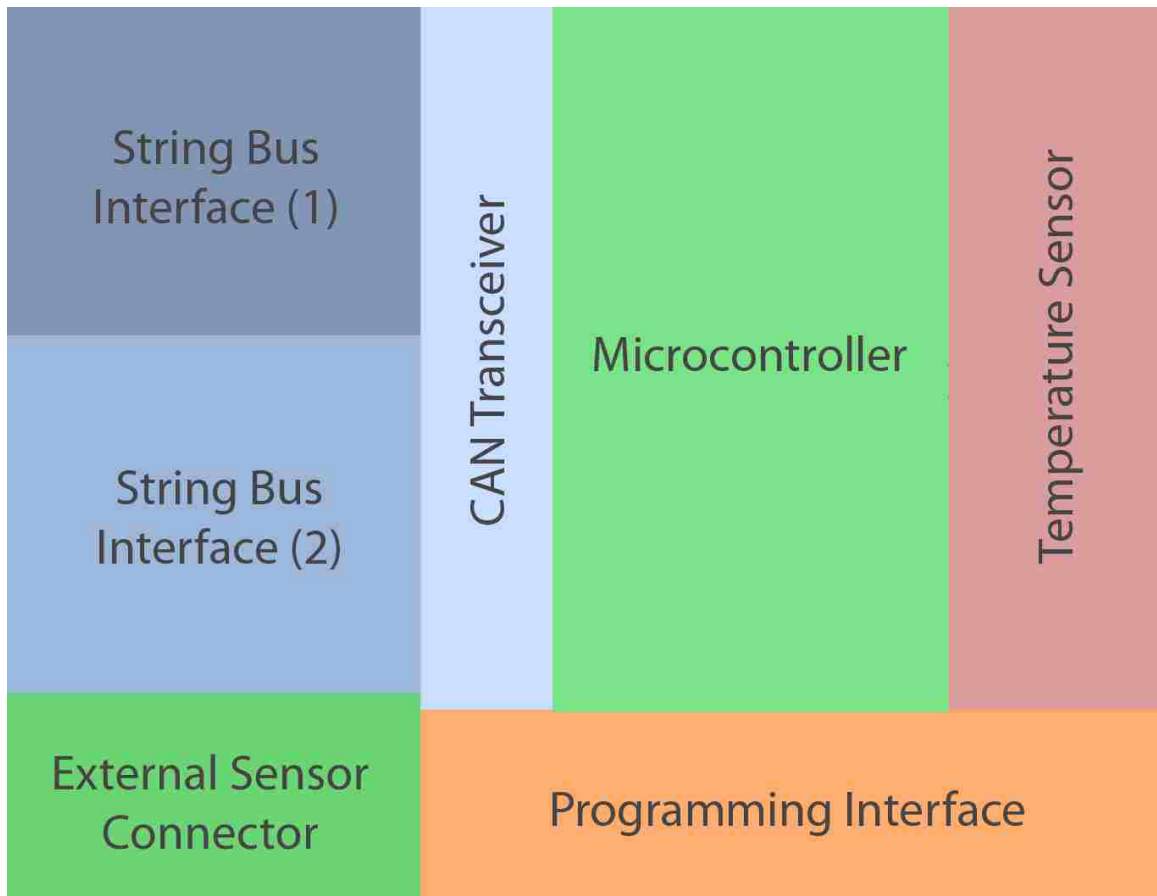

Figure D.1. Layout of the Sensor Node (Large)

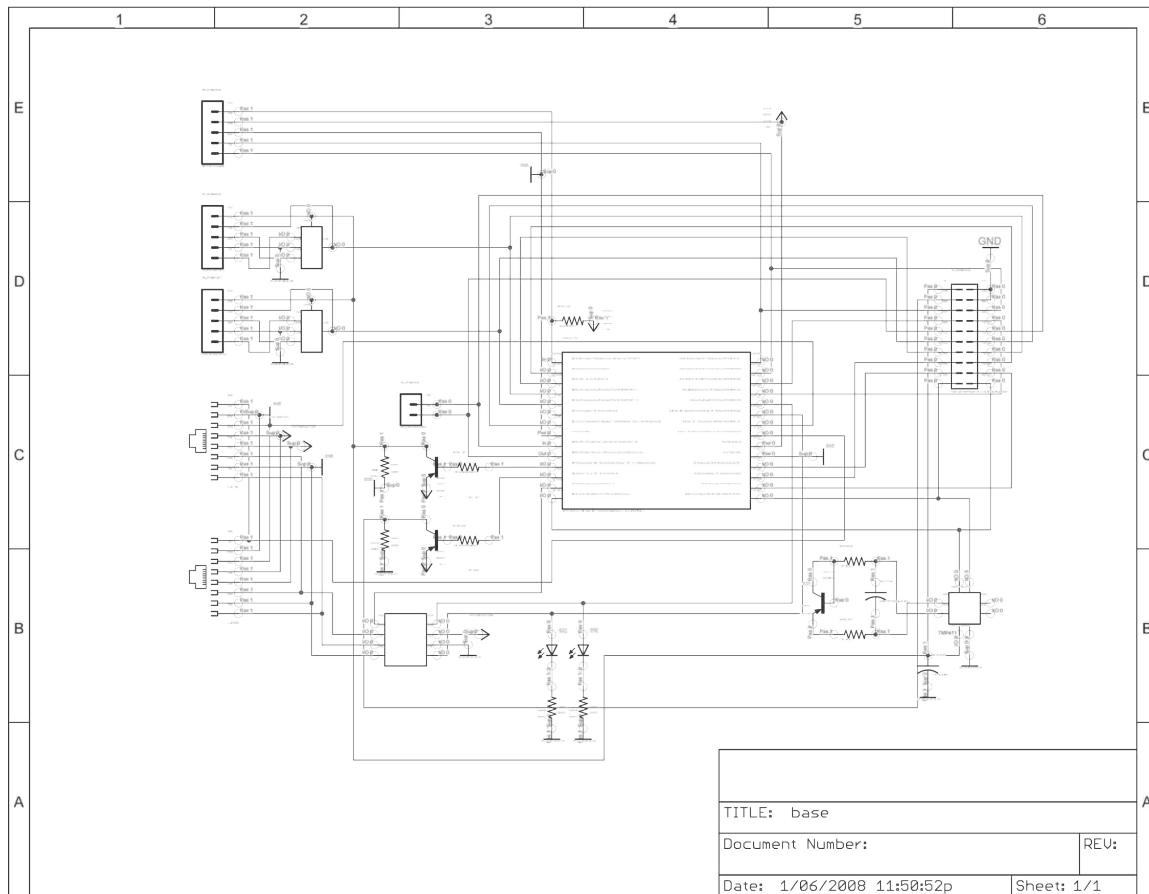

Figure D.2. Schematic of the Sensor Node (Large)

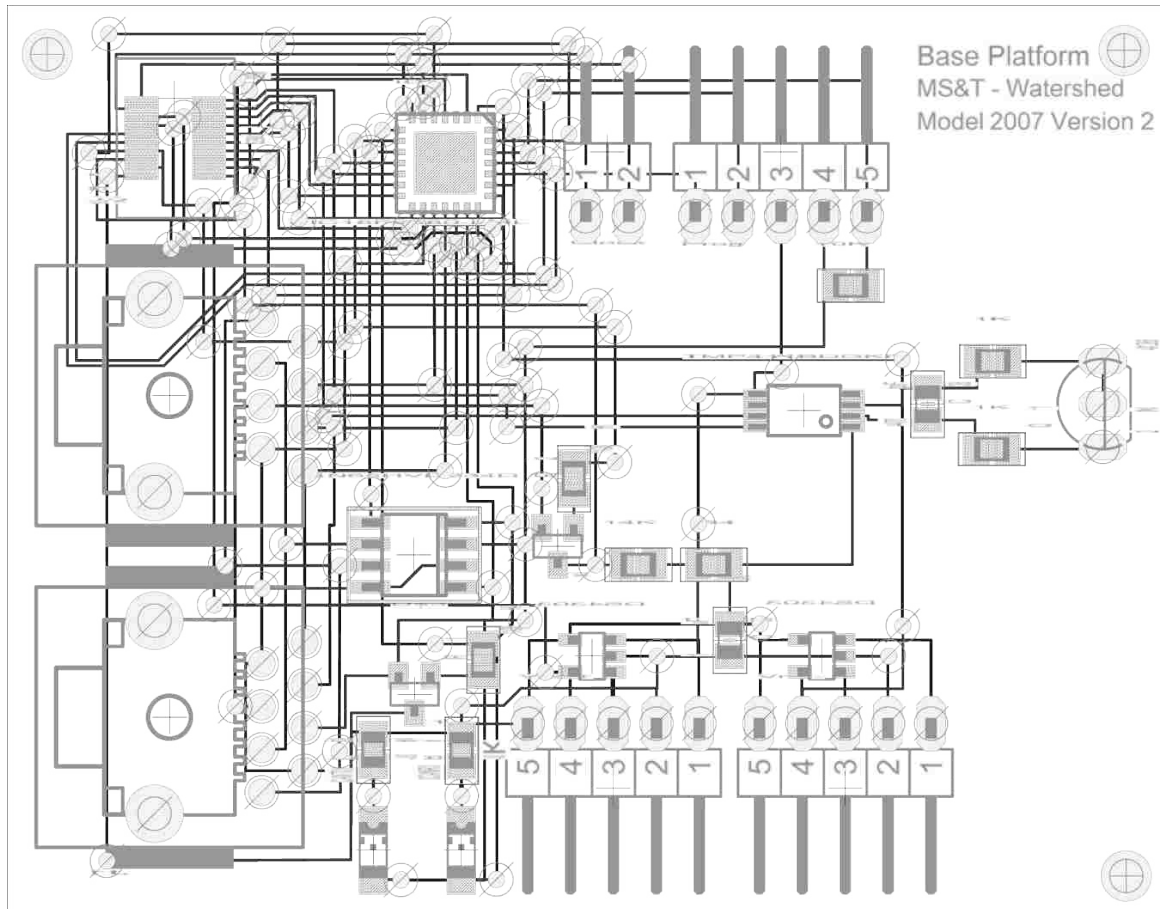

Figure D.3. PCB of the Sensor Node (Large)

APPENDIX E

FLOW CHARTS FOR BASE STATION SOFTWARE

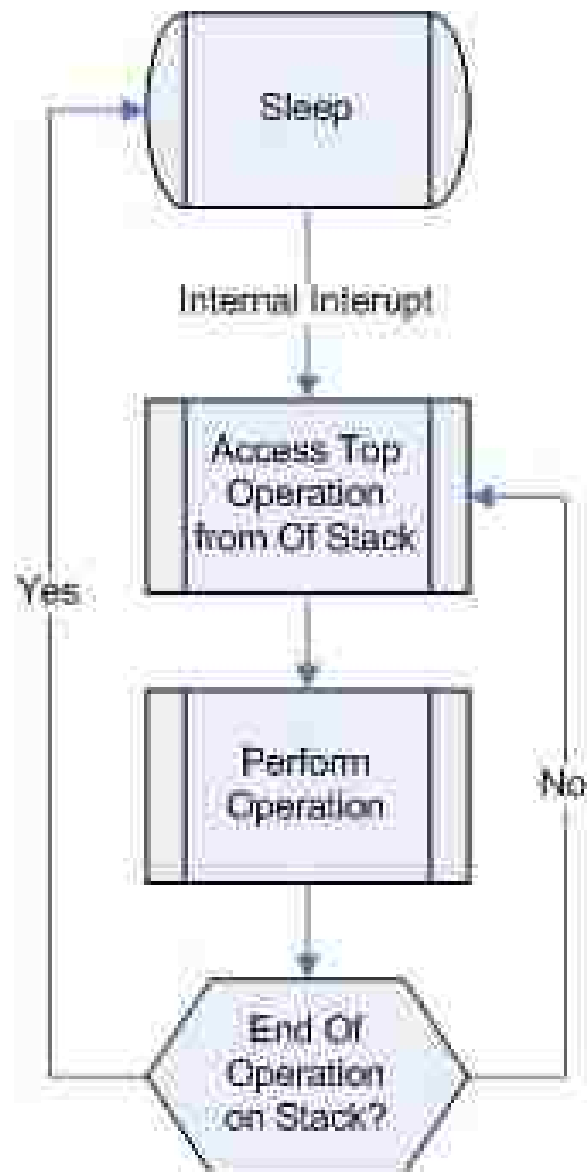

Figure E.1. Flow Chart of the Base Station Operation - Level 1

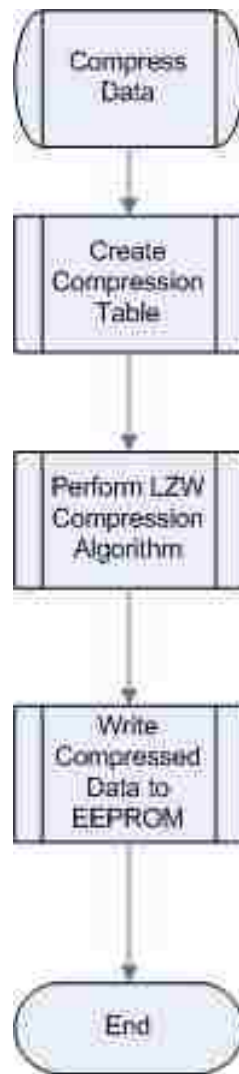

Figure E.2. Flow Chart of the Base Station Operation - Level 2 Item 1

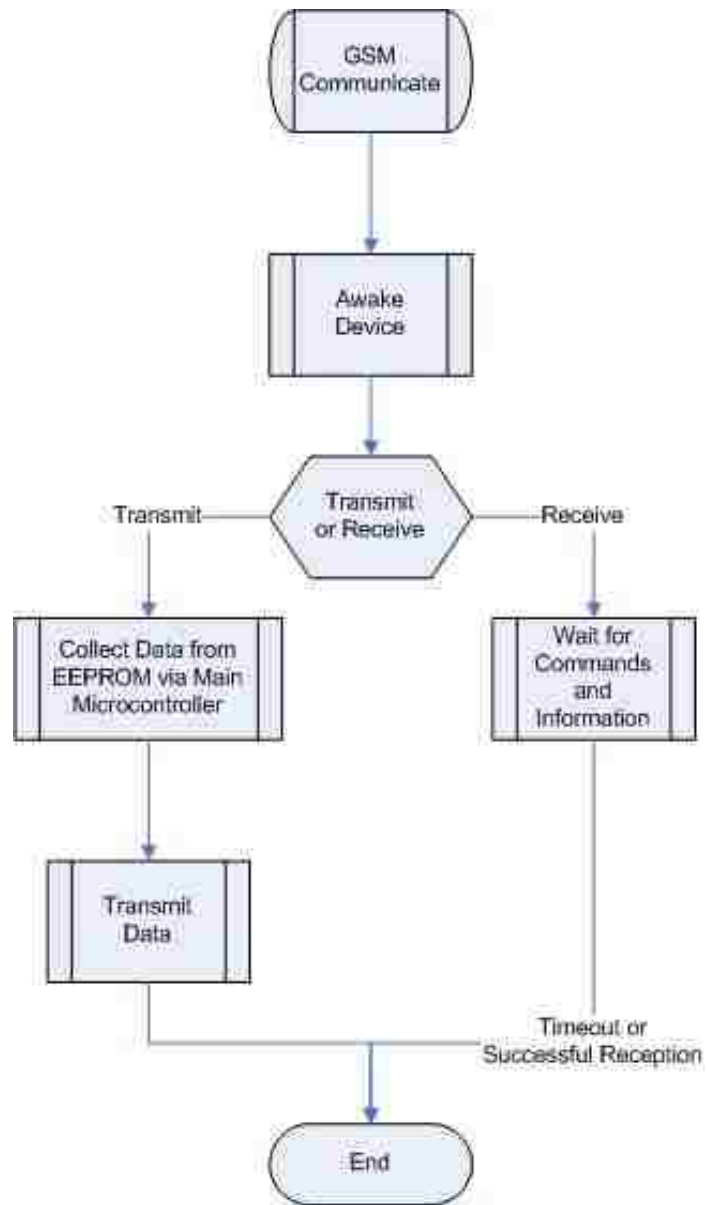

Figure E.3. Flow Chart of the Base Station Operation - Level 2 Item 2



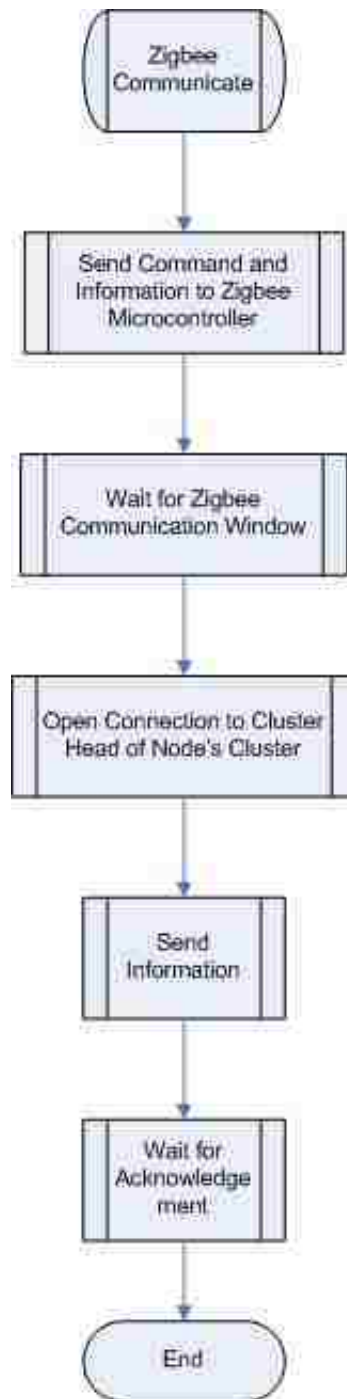

Figure E.4. Flow Chart of the Base Station Operation - Level 2 Item 3

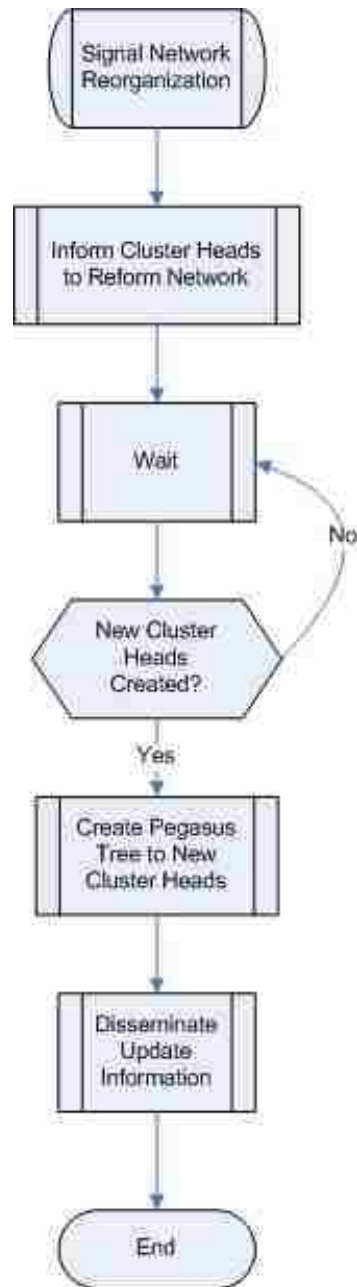

Figure E.5. Flow Chart of the Base Station Operation - Level 2 Item 4

## APPENDIX F

### FLOW CHARTS FOR COMMUNICATION ACCESS POINT SOFTWARE

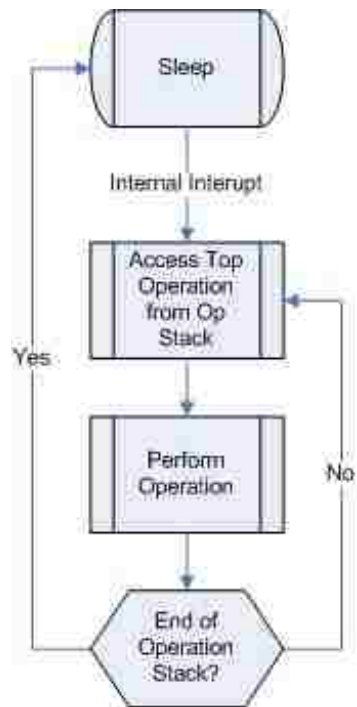

Figure F.1. Flow Chart of the Communication Access Point Operation - Level 1

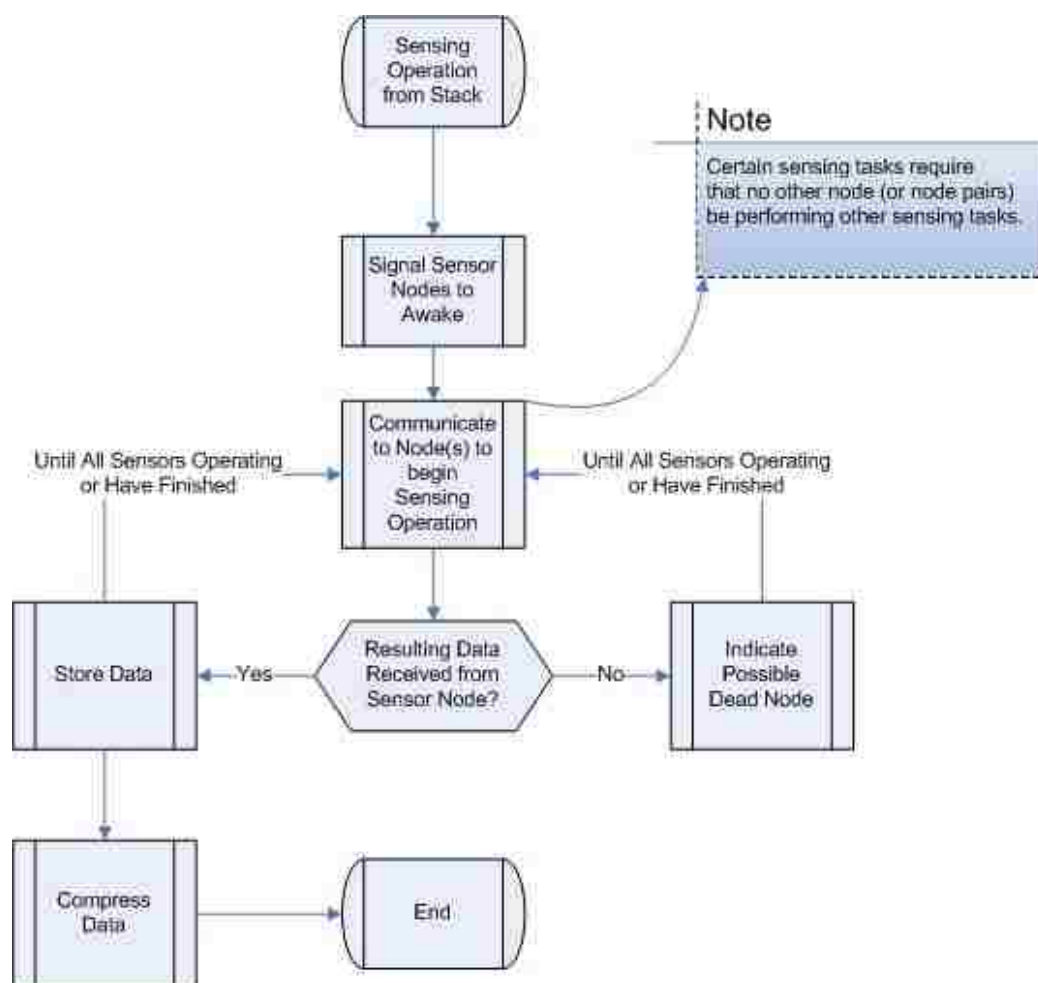

Figure F.2. Flow Chart of the Communication Access Point Operation - Level 2 Item 1

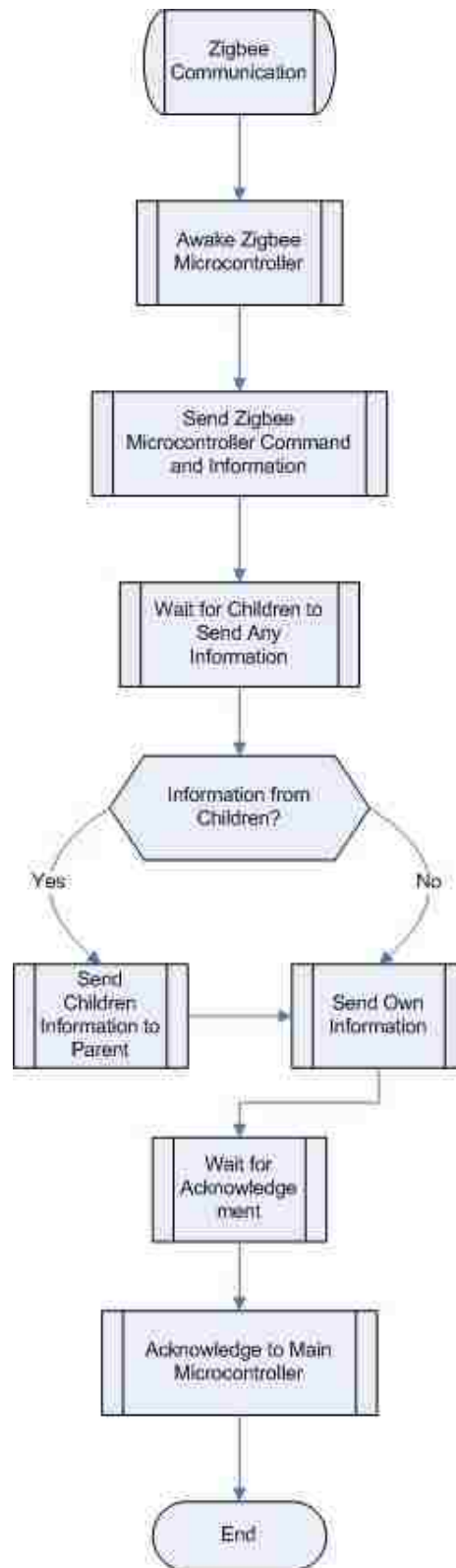

Figure F.3. Flow Chart of the Communication Access Point Operation - Level 2 Item 2

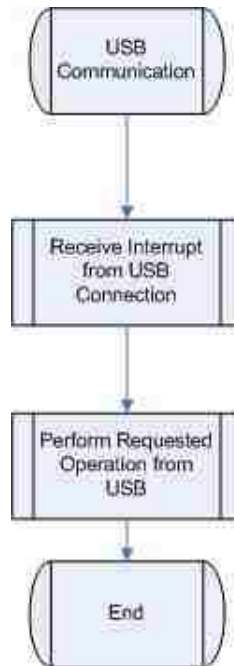

Figure F.4. Flow Chart of the Communication Access Point Operation - Level 2 Item 3

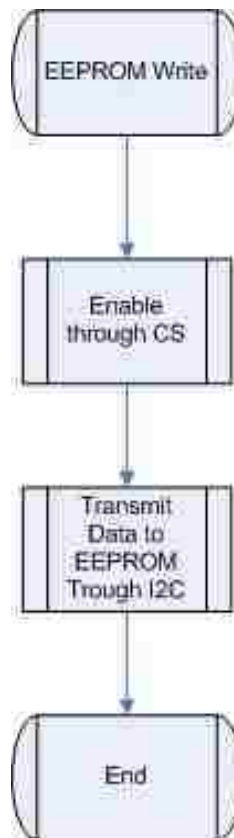

Figure F.5. Flow Chart of the Communication Access Point Operation - Level 2 Item 4

APPENDIX G

FLOW CHART FOR SENSOR NODE FLOW SOFTWARE



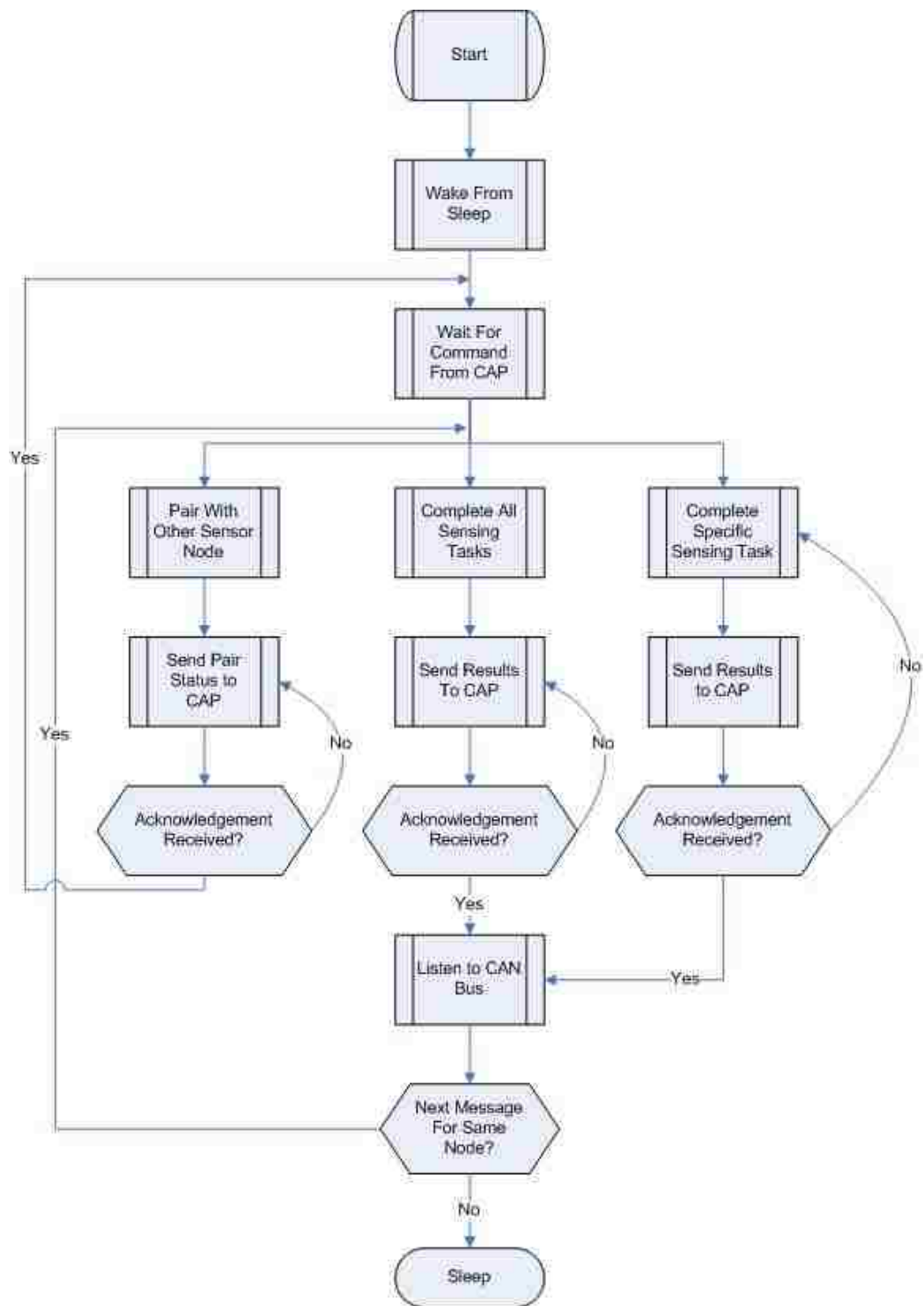

Figure G.1. Flow Chart of the Sensor Node

APPENDIX H  
POWER CONSUMPTION ESTIMATES

## Power Estimation

	Single Cost (Amp/Sec)	Times Per Day (Per Sec)	Cost Per Hour	Cost Per Day	Cost Per Week	Cost Per Month	Cost Per Year	Cost Per Lifetime	Cost Per Lifetime With Power Leakage	Cost Per Lifetime With Power Leakage (Amp/Hrs)	Cost Per Lifetime With Power Leakage (Amp/Hrs)
DC-DC Converters	0.0001	86400	0.1600	4.3200	30.2400	129.6000	1576.8000	7694.0000	8081.1000	2.1900	2.2448
Switch	0.0000	86400	0.0000	0.0000	0.0000	2.5920	31.1040	157.0000	167.6220	0.0408	0.0449
Total	0.0001		0.1600	4.3200	30.2400	132.1920	1608.3360	8041.0000	8248.7220	2.2308	2.2897

## Sensor Node Estimation

	Single Cost (Amp/Sec)	Times Per Day (Per Sec)	Cost Per Hour	Cost Per Day	Cost Per Week	Cost Per Month	Cost Per Year	Cost Per Lifetime	Cost Per Lifetime With Power Leakage	Cost Per Lifetime (Amp/Hrs)	Cost Per Lifetime With Power Leakage (Amp/Hrs)
Main uC - Sleep	0.000002	86399.50	0.0072	0.1728	1.2096	5.1840	63.0716	315.3582	323.2421	0.0876	0.0898
Main uC - Full	0.001025	0.50	0.0000	0.0005	0.0036	0.0154	0.1877	0.9386	0.9620	0.0003	0.0003
CAN - Sleep	0.000000	66400.00	0.0002	0.0043	0.0302	0.1296	1.5768	7.8840	8.0811	0.0022	0.0022
CAN - Full	0.042000	0.00	0.0000	0.0001	0.0005	0.0022	0.0267	0.1334	0.1367	0.0000	0.0000
Temperature Sensor	0.00012	0.50	0.0000	0.0001	0.0004	0.0018	0.0219	0.1095	0.1122	0.0000	0.0000
TDT/TDR Estimate	0.001	0.50	0.0000	0.0005	0.0035	0.0150	0.1825	0.9125	0.9353	0.0003	0.0003
<b>Total</b>	<b>0.0441</b>		<b>0.0074</b>	<b>0.1783</b>	<b>1.2479</b>	<b>5.3480</b>	<b>65.0672</b>	<b>325.3361</b>	<b>333.4695</b>	<b>0.0904</b>	<b>0.0926</b>

## CAP Node Estimation

	Single Cost (Amp/Sec)	Times Per Day (Per Sec)	Cost Per Hour	Cost Per Day	Cost Per Week	Cost Per Month	Cost Per Year	Cost Per Lifetime	Cost Per Lifetime With Power Leakage	Cost Per Lifetime (Amp/Hrs)	Cost Per Lifetime With Power Leakage (Amp/Hrs)
Main uC - Sleep	0.000002	86348.67	0.0072	0.1727	1.2089	5.1809	63.0345	315.1727	323.0520	0.0875	0.0897
Main uC - Full	0.001025	51.33	0.0022	0.0526	0.3683	1.5783	19.2021	96.0105	98.4107	0.0267	0.0273
CAN - Sleep	0.000000	86399.83	0.0002	0.0043	0.0302	0.1296	1.5768	7.8840	8.0811	0.0022	0.0022
CAN - Full	0.042000	0.17	0.0003	0.0073	0.0512	0.2192	2.6674	13.3371	13.6705	0.0037	0.0038
Zigbee - Tx	0.027	0.00	0.0000	0.0000	0.0000	0.0000	0.0003	0.0017	0.0016	0.0000	0.0000
Zigbee - Rx	0.027	0.00	0.0000	0.0000	0.0000	0.0000	0.0001	0.0004	0.0004	0.0000	0.0000
Zigbee - Sleep	0.0000002	86400.00	0.0007	0.0173	0.1210	0.5184	6.3072	31.5360	32.3244	0.0088	0.0090
<b>Total</b>	<b>0.097027</b>		<b>0.0106</b>	<b>0.2542</b>	<b>1.7795</b>	<b>7.6265</b>	<b>92.7885</b>	<b>463.9424</b>	<b>475.5409</b>	<b>0.1289</b>	<b>0.1321</b>

## Base Station Estimation

	Single Cost (Amp/Sec)	Times Per Day (Per Sec)	Cost Per Hour	Cost Per Day	Cost Per Week	Cost Per Month	Cost Per Year	Cost Per Lifetime	Cost Per Lifetime With Power Leakage	Cost Per Lifetime (Amp/Hrs)	Cost Per Lifetime With Power Leakage (Amp/Hrs)
Main uC - Sleep	0.000	86397.193	0.007	0.173	1.210	5.184	63.070	315.350	323.233	0.088	0.090
Main uC - Full	0.001	2.807	0.000	0.003	0.020	0.086	1.050	5.252	5.383	0.001	0.001
Zigbee - Tx	0.027	0.001	0.000	0.000	0.000	0.001	0.009	0.044	0.045	0.000	0.000
Zigbee - Rx	0.027	0.004	0.000	0.000	0.001	0.003	0.035	0.174	0.179	0.000	0.000
Zigbee - Sleep	0.000	86399.996	0.001	0.017	0.121	0.518	6.307	31.536	32.324	0.009	0.009
Cellular Module - Tx	0.440	0.197	0.004	0.087	0.606	2.599	31.617	158.086	162.038	0.044	0.045
Cellular Module - Rx	0.440	0.304	0.006	0.134	0.935	4.007	48.754	243.768	249.862	0.068	0.069
Cellular Module - Sleep	0.000	86399.500	0.396	9.504	66.528	285.118	3468.940	17344.700	17778.317	4.818	4.938
Cost Per Power Node	0.000	1.000	0.184	4.406	30.845	132.192	1608.336	8041.680	8242.722	2.234	2.280
Total	0.935		0.597	14.324	100.265	429.708	5228.118	26140.588	26794.103	7.261	7.443

## BIBLIOGRAPHY

- [1] L. Band, F. Ogden, J. Butler, D. C. Goodrich, R. Hooper, D. Kane, B. Lyons, D. McKnight, N. Miller, M. Williams, K. Potter, B. Scanlon, R. Pielke, and K. Reckhow, "Hydrologic Observatory Network," CUAHSI, Tech. Rep., April 2002. [Online]. Available: [http://www.cuahsi.org/publications/cuahsi\\_tech\\_rpt\\_4.pdf](http://www.cuahsi.org/publications/cuahsi_tech_rpt_4.pdf)
- [2] "Sentilla - TMote," 2008. [Online]. Available: <http://www.sentilla.com/>
- [3] "Crossbow," 2008. [Online]. Available: <http://www.xbow.com/Home/HomePage.aspx>
- [4] P. Dawes, "End-to-End Interworking and Roaming Test Specification for IMS," GSM Association, Tech. Rep., 2006. [Online]. Available: [www.gsmworld.com](http://www.gsmworld.com)
- [5] Zigbee Alliance Board of Directors, "Zigbee Alliance, Zigbee Specification." ZigBee Alliance, Tech. Rep., 2005. [Online]. Available: <http://www.zigbee.org>
- [6] M. Bourgeois, S. Moridi, and P. Jamieson, "802.15.4," IEEE, Tech. Rep., October 2003, part 15.4: Wireless Medium Access Control (MAC) and Physical Layer (PHY) Specifications for Low-Rate Wireless Personal Area Networks (LR-WPANs).
- [7] "Specification of the Bluetooth System," 2007.
- [8] "Wireless Universal Serial Bus Specification," 2005.
- [9] R. Bosch Ghmb, "CAN Specification," BOSCH, Tech. Rep. 2, 1991.
- [10] P. Richards, "A CAN Physical Layer Discussion," Microchip Technology, INC., Tech. Rep., 2002.
- [11] O. Gnawali, B. Greenstien, K.-Y. Jang, A. Joki, J. Paek, M. Vieira, D. L. Estrin, R. Govindan, and E. Kohler, "The Tenet Architecture for Tiered Sensor Networks," *Proceedings of ACM: SenSys*, 2006.
- [12] J. L. Montgomery, T. Harmon, W. Kaiser, A. Sanderson, C. N. Haas, R. Hooper, B. Minsker, J. Schnoor, N. L. Clesceri, and P. Brezonik, "The WATERs Network: An Integrated Environmental Observatory Network for Water Research," *Environmental Science & Technology*, pp. 6642–6647, October 2007.
- [13] S. H. L. Liang, A. Croitoru, and C. V. Tao, "A Distributed Geospatial Infrastructure for Sensor Web," *Computers & Geosciences*, vol. 31, pp. 221–231, 2005.

- [14] S. Chien, B. Cichy, D. Tran, G. Rabideau, R. Castano, R. Sherwood, S. Nghiem, R. Greeley, T. Doggett, V. Baker, J. M. Dohm, F. Ip, D. Mandl, S. Frye, S. Shulman, S. Ungar, T. Brakke, L. Ong, J. Descloitres, S. Grosvenor, R. Wright, L. P. Flynn, A. J. L. Harris, R. Brakenridge, and S. Cacquard, "An Autonomous Earth Observing Sensorweb," *Proceedings of the IEEE International Conference on Sensor Networks, Ubiquitous, and Trustworthy Computing*, 2006.
- [15] W. Kaiser, G. Pottie, M. Srivastava, G. Sukhatme, J. Villasenor, and D. L. Estrin, "Networked Infomechanical Systems (NIMS) for Ambient Intelligence," UCLA Center for Embedded Networked Sensing, Technical Report 31, December 2003.
- [16] K. A. Delin, S. P. Jackson, D. W. Johnson, S. C. Burleigh, R. R. Woodrow, J. M. McAuley, J. T. Britton, J. M. Dohm, T. P. A. Ferré, F. Ip, D. F. Rucker, and V. R. Baker, "Sensor Web for Spatio-Temporal Monitoring of a Hydrological Environment," in *35th Lunar and Planetary Science Conf.*, 2004.
- [17] K. A. Delin, S. P. Jackson, D. W. Johnson, S. C. Burleigh, R. R. Woodrow, J. M. McAuley, J. M. Dohm, F. Ip, T. P. A. Ferré, D. F. Rucker, and V. R. Baker, "Environmental Studies with the Sensor Web: Principles and Practice," in *Sensors*, 2005, pp. 103–117.
- [18] M. Castillo-Effen, "Wireless Sensor Networks for Flash-Flood Alerting," in *Proc. of the 5th IEEE Int'l Caracas Conference on Devices, Circuits and Systems, Dominican Republic*, 2004, pp. 142–146.
- [19] T. Jackson, D. Le Vine, A. Griffis, D. Goodrich, T. Schmutge, C. Swift, and P. O'Neill, "Soil Moisture and Rainfall Estimation Over a Semiarid Environment With the ESTAR Microwave Radiometer," *Geoscience and Remote Sensing, IEEE Transactions on*, vol. 31, no. 4, pp. 836–841, July 1993. [Online]. Available: <http://ieeexplore.ieee.org/iel1/36/6165/00239906.pdf>
- [20] V. M. Trifa, L. Girod, T. Collier, D. T. Blumstein, and C. E. Taylor, "Automated Wildlife Monitoring Using Self-Configuring Sensor Networks Deployed in Natural Habitats," November 2006.
- [21] R. Cardell-Oliver, M. Kranz, K. Smettem, and K. Mayer, "A Reactive Soil Moisture Sensor Network: Design and Field Evaluation," *International Journal of Distributed Sensor Networks*, vol. 1, pp. 149–162, April-June 2005. [Online]. Available: <http://www.csse.uwa.edu.au/adhocnets/WSNgroup/soil-water-proj/>
- [22] M. Veenstra, D. J. White, and V. R. Schaefer, "Synthesis of NonDestructive Testing Technologies for Geomaterial Applications," *Iowa Department of Transportation*, May 2005. [Online]. Available: [http://www.ctre.iastate.edu/reports/nde\\_geo.pdf](http://www.ctre.iastate.edu/reports/nde_geo.pdf)
- [23] A. Pozdnyakov and L. Pozdnyakova, "Electrical Fields and Soil Properties," *Proceedings of 17th World Congress of Soil Science*, no. 1558, 2002. [Online]. Available: <http://www.landviser.com/PDF/17WorldCongressofSoilScience.pdf>



- [24] J. S. Selker, L. Thévenaz, H. Huwald, A. Mallet, W. Luxemburg, N. van de Giesen, M. Stejskal, J. Zeman, and M. Parlange, “Distributed Fiber-Optic Temperature Sensing for Hydrologic Systems,” *Water Resources Research*, vol. 42, no. W12202, pp. 1–8, October 2006.
- [25] D. M. Doolin and N. Sitar, “Wireless Sensor for Wildfire Monitoring,” in *Proceedings of SPIE Symposium on Smart Structures & Materials*, March 2005. [Online]. Available: <http://firebug.sourceforge.net/spie2005.pdf>
- [26] J. Polastre, R. Szewczyk, and D. Culler, “Telos: Enabling Ultra-Low Power Wireless Research,” *Telos*, pp. 1–6, February 2005.
- [27] BOPLA, “Protection Classification IP 68,” [http://www.bopla.de/english/technische\\_informationen/ip68.html](http://www.bopla.de/english/technische_informationen/ip68.html).
- [28] URCAG, “Restriction of Hazardous Substances RoHS,” <http://www.rohsgroup.com/>.
- [29] “System Management Bus (SMBus) Specification,” 2000.
- [30] T. A. Welch, “High Speed Data Compression and Decompression Apparatus and Method,” December 1985.
- [31] —, “A Technique for High-Performance Data Compression,” *IEEE Computer*, vol. 17, pp. 8–19, June 1984.
- [32] “The I<sup>2</sup>C-Bus Specification,” 2000.
- [33] S. Lindsey, C. Raghavendra, and K. M. Sivalingam, “Data Gathering Algorithms in Sensor Networks Using Energy Metrics,” *IEEE Transactions on Parallel and Distributed Systems*, vol. 13, no. 9, pp. 924–935, September 2002. [Online]. Available: <http://ieeexplore.ieee.org/search/wrapper.jsp?arnumber=1036066>
- [34] W. R. Heinzelman, A. P. Chandrakasan, and H. Balakrishnan, “An Application-Specific Protocol Architecture for Wireless Microsensor Networks,” *IEEE Transactions on Wireless Communications*, vol. 1, no. 4, pp. 660–670, October 2002.

## VITA

John Regis Koch was born in Webb City, Missouri on January 7, 1985. In May 2007, he graduated from the University of Missouri - Rolla with a Bachelor's degree in Computer Engineering and a Bachelor's degree in Computer Science. In May 2008, he received his Master's of Science in Electrical Engineering from Missouri University of Science and Technology.

