

---

Masters Theses

Student Theses and Dissertations

---

Fall 2008

## Statistical estimation of crosstalk for cable bundles

Meilin Wu

Follow this and additional works at: [https://scholarsmine.mst.edu/masters\\_theses](https://scholarsmine.mst.edu/masters_theses)



Part of the [Electrical and Computer Engineering Commons](#)

Department:

---

### Recommended Citation

Wu, Meilin, "Statistical estimation of crosstalk for cable bundles" (2008). *Masters Theses*. 4640.  
[https://scholarsmine.mst.edu/masters\\_theses/4640](https://scholarsmine.mst.edu/masters_theses/4640)

This thesis is brought to you by Scholars' Mine, a service of the Missouri S&T Library and Learning Resources. This work is protected by U. S. Copyright Law. Unauthorized use including reproduction for redistribution requires the permission of the copyright holder. For more information, please contact [scholarsmine@mst.edu](mailto:scholarsmine@mst.edu).



**STATISTICAL ESTIMATION OF CROSSTALK FOR CABLE BUNDLES**

**by**

**MEILIN WU**

**A THESIS**

**Presented to the Faculty of the Graduate School of the  
MISSOURI UNIVERSITY OF SCIENCE AND TECHNOLOGY**

**In Partial Fulfillment of the Requirements for the Degree**

**MASTER OF SCIENCE IN ELECTRICAL ENGINEERING**

**2008**

**Approved by**

**Daryl G. Beetner, Advisor  
David Pommerenke  
Todd Hubing**

© 2008

Meilin Wu

All Rights Reserved

**PUBLICATION DISSERTATION OPTION**

This thesis has been prepared in two papers for publication in the style used by the Missouri University of Science and Technology. Pages 3-28 have been submitted for publication in the IEEE Transactions on Electromagnetic Compatibility. Pages 29-39 will be submitted for publication in the IEEE Transactions on Electromagnetic Compatibility.

## ABSTRACT

Predicting electromagnetic interference problems for cable bundles early in the design stage is of significant value for both automotive and other industries. Effective methods are needed for predicting interference when little design information is known. The random variation in parameters like wire position in the bundle require that statistical variations be taken into account.

In the first part of this thesis, a method to analytically predict the “reasonable worst-case crosstalk” within a cable bundle is proposed. The method uses the per-unit-length LC matrices associated with the cross-sectional geometry of the bundle to generate probability a distribution function for mutual inductance and capacitance between wires within the bundle. A probability function for the effective capacitance and inductance associated with a cable configuration can then be determined by dividing the harness into segments, where wire position changes from segment to segment. Crosstalk can be decomposed into inductive coupling and capacitive coupling components and can be estimated separately using the effective inductance and capacitance information.

In the second part of this thesis, a fast simulation method to estimate the crosstalk in cable bundles is proposed. The method makes use of the T-parameter (Transfer parameter) matrix and can be implemented with a simple MATLAB script. This simulation method is more than 200 times faster than traditional SPICE simulation, which is of significant value when a large number of simulations is needed for statistical analysis.

## ACKNOWLEDGMENTS

I would like to express my sincere gratitude to my advisor, Dr. Daryl Beetner, for his support and ever positive attitude towards my research work. I have learned immensely from the numerous technical and non-technical discussions I have had with him. Also, I would like to express my gratitude to General Motors for sponsoring my research in the past two years.

I am grateful to Dr. David Pommerenke for his insightful courses and for accepting to be on my advisory committee. I am also grateful to Dr. Todd Hubing for his advice on my research work and willingness to serve on the committee. I would like to thank Dr. Jun Fan for his suggestions in part of my research work. I would also like to thank the faculty and students of the Missouri S&T EMC Laboratory, for their intelligent discussions in my research area. I would like to thank my friends who have directly or indirectly helped me along the path to success.

Most importantly, I would like to express heartfelt thanks to my wife, parents and other family members for their constant support.

## TABLE OF CONTENTS

	Page
PUBLICATION DISSERTATION OPTION.....	iii
ABSTRACT.....	iv
ACKNOWLEDGMENTS .....	v
LIST OF ILLUSTRATIONS.....	viii
LIST OF TABLES.....	x
INTRODUCTION .....	1
1. STATISTICAL PREDICTION OF “REASONABLE WORST-CASE” CROSSTALK IN CABLE BUNDLES .....	3
ABSTRACT .....	3
1.1. INTRODUCTION.....	3
1.2. ESTIMATION OF VARIATION OF INDUCTANCE AND CAPACITANCE...5	5
1.3. ESTIMATION OF “REASONABLE WORST-CASE” CROSSTALK.....	10
1.4. APPLICATION OF THE METHOD.....	14
1.4.1. Scenario 1: 3 wires, height = 2 cm, 50 ohm and 1 kohm terminations.....	15
1.4.2. Scenario 2: 14 wires, height = 2 cm, all terminations 50 ohms .....	15
1.4.3. Scenario 3: 14 wires, height = 2 cm, all terminations 1 kohm. ....	15
1.4.4. Scenario 4: 14 wires, lying on return plane, all terminations either 50 ohms or all terminations 1 kohm. ....	18
1.4.5. Scenario 5: 14 wires, lying on return plane, terminations varied to mimic realistic harness impedances. ....	21
1.4.6. Scenario 6: 14 wires, lying on return plane, all terminations either 50 ohms or 1 kohm; presence of return wire.....	22
1.5. DISCUSSION .....	24
1.6. CONCLUSION .....	25
REFERENCES.....	27
2. IMPROVING CROSSTALK SIMULATION SPEEDS FOR CABLE HARNES BUNDLES USING THE T-PARAMETER METHOD.....	29
ABSTRACT .....	29
2.1 INTRODUCTION.....	29
2.2 THE T-PARAMETER MATRIX .....	30



2.3	CIRCUIT MODEL.....	32
2.4	OBTAINING THE ADMITTANCE MATRIX.....	34
2.5	PERFORMANCE .....	35
2.6	DISCUSSION AND CONCLUSIONS.....	38
	REFERENCES.....	39
	VITA.....	40

## LIST OF ILLUSTRATIONS

Figure	Page
1.1. Cross section of a 14 wire harness.....	6
1.2. Probability distribution for per-unit-length mutual inductance in wiring harness containing 14 20-gauge wires 2 cm above a return plane.....	8
1.3. Probability distribution of “effective” per-unit-length mutual inductance for wiring harness containing 14 20-gauge wires 2 cm above a return plane.....	8
1.4. Probability distribution of per-unit-length mutual capacitance for a single segment of a harness containing 14 20-gauge wires 2 cm above a return plane.....	9
1.5. Probability distribution of the “effective” per unit length mutual capacitance for a wiring harness containing 14 20-gauge wires 2 cm above a return plane.....	9
1.6. Low-frequency model for crosstalk.....	10
1.7. Circuit model approximating strong inductive coupling.....	12
1.8. Circuit model approximating strong capacitive coupling.....	13
1.9. Near-end crosstalk when all circuits were loaded with 50 ohms.....	16
1.10. Far-end crosstalk when all circuits were loaded with 50 ohms.....	16
1.11. Near-end crosstalk when all circuits were loaded with 1 kohm.....	17
1.12. Far-end crosstalk when all circuits were loaded with 1 kohm.....	17
1.13. Far-end crosstalk when the bundle was lying on the return plane and all circuits were loaded with 50 ohms.....	18
1.14. Far-end crosstalk when the bundle was lying on the return plane and all circuits were loaded with 1 kohm.....	19
1.15. Far-end crosstalk from circuit 2 to circuit 1 when the bundle was loaded as shown in Table 1.1.....	20
1.16. Far-end crosstalk from circuit 2 to circuit 10 when the bundle was loaded as shown in Table 1.1.....	20
1.17. Far-end crosstalk from circuit 1 to circuit 2 when the bundle was loaded as shown in Table 1.1.....	22
1.18. Far-end crosstalk from circuit 1 to circuit 7 when the bundle was loaded as shown in Table 1.1.....	23
1.19. Far-end crosstalk when the bundle was lying on the return plane and all wires were loaded with 50 ohms except a return wire.....	23

1.20. Far-end crosstalk when the bundle was lying on the return plane and all wires were loaded with 1 kohm except a return wire .....	24
2.1. Network with 2n ports and the associated incident and reflected waves.....	31
2.2. An overall network consisting of x cascaded individual networks.....	32
2.3. Simplified circuit model for a 3-wire bundle.....	33
2.4. The model for the cable bundle shown in Figure 2.3 with defined ports .....	34
2.5. An approach for estimating the admittance matrix.....	35
2.6. Comparison of the simulation results for far-end crosstalk from circuit 2 to circuit 1 for a 14-wire bundle when all wires are loaded with 50 ohm at both ends .....	37

**LIST OF TABLES**

Table	Page
1.1. Near-end and far-end loads.....	19

## INTRODUCTION

Electrical systems in automobiles and other vehicles should be evaluated for electromagnetic compatibility (EMC) problems early in the design process. The challenge is developing methods that can account for the considerable complexity of modern vehicle designs while delivering estimates of acceptable accuracy at an acceptable speed. Full-wave numerical models can deliver highly accurate solutions but may require considerable time to simulate and prepare models of geometry. Obtaining accurate models of geometry early in the design process may also be a challenge, since the vehicle geometry may not yet be fully specified. Even when available, there is the additional problem of refining the geometry to a form that allows simulations to be performed in a reasonable amount of time. This refinement process is not always straightforward and often requires considerable human interaction. Accounting for the wide statistical variation in system parameters like the position of wires within a harness, the height of the wires, circuit terminations, and the like only adds to the challenge of calculating results with these tools.

One option for discovering EMC problems early in the design process is to use lumped-element approximations of crosstalk to determine worst-case coupling between circuits. The advantage of this approximation is that calculations can be made very quickly with a limited amount of information. This approach has been shown to work well up to several tens of MHz in experiments in an automobile, though there is a risk of overestimating the coupling that is likely to occur. Experiments have shown worst-case calculations may overestimate crosstalk by as much as 20 dB depending on harness configuration.

Paper 1 of this thesis proposes a method for estimating the “reasonable worst-case” crosstalk between circuits within a cable harness bundle. This method models the randomness of wire position using a segmentation technique. It described the bundle as a lumped element circuit model and studies the probability distribution of inductive and capacitive coupling separately.

Paper 2 proposes a fast simulation method of crosstalk simulation for cable bundles. It uses T-parameter (Transfer parameter) matrices and can be performed with a simple MATLAB script. The theory behind the technique and experiments showing its accuracy and speed will be presented.

# 1. STATISTICAL PREDICTION OF “REASONABLE WORST-CASE” CROSSTALK IN CABLE BUNDLES

Meilin Wu, Daryl G. Beetner, Todd H. Hubing, Haixin Ke, and Shishuang Sun

## ABSTRACT

Worst-case estimates of crosstalk in cable bundles are useful for flagging potential problems, but may flag problems that occur only very rarely, due to the random variation of wire positions and other characteristics of the harness. Prediction of crosstalk that may realistically occur requires statistical methods. Monte-Carlo simulation techniques are often used to account for statistical variation, but are time consuming and do not provide intuition toward the cause of or solution to problems. Here we investigate prediction of the statistically “reasonable worst-case” crosstalk by forming probability distributions using inductance and capacitance parameters from a single harness cross-section and using lumped element approximations for crosstalk that account for strong coupling within the harness when the circuit is electrically small. The accuracy of this technique was evaluated through comparison to simulation results using the Random Displacement Spline Interpolation (RDSI) method for multiple random instantiations of several harness configurations. Tests were performed while varying the size of the bundle, its height above the return plane, the value of load impedances, and the presence of a return wire. The reasonable worst-case crosstalk was estimated within about 5 dB or less in each case.

## 1.1. INTRODUCTION

Predicting electromagnetic interference problems early in the design process is a significant challenge in automotive design and many other industries. Complex simulation tools have the potential to estimate interference very accurately, but

significant time is required to enter design information and to perform simulations, and results are not always easy to interpret. While the presence of a problem may be found with these tools, the problem's cause or solution may not be obvious. Statistical variation of system parameters, like the random variation of wire position within a harness, adds to the challenge [1], [2]. Accounting for statistical variations using simulation models typically requires simulation of many possible design configurations to estimate the range of interference problems. Worst-case analysis using lumped-element models provides rapid solutions at low frequencies with a clear indication of the parameters that may cause or solve a problem [3], though such solutions may be too conservative and overestimate interference that is statistically likely to occur [4]. Methods are needed to quickly estimate statistically reasonable estimates of crosstalk in a way that also allows a clear to link between the observed interference and the system characteristics that cause that interference.

Several methods have been developed for estimating the statistical variation of crosstalk in cable harness bundles. Efforts to develop a closed form estimate of statistical variation have so far been unsuccessful, requiring at least some numerical intervention to generate results [5]. Most solutions rely on Monte Carlo simulation of multiple harness configurations. For example, Ciccolella and Canavero use Monte Carlo methods to estimate a cumulative distribution function for crosstalk through numerical solution of multi-conductor transmission line equations [6]. Position is varied by segmenting the harness along its length and choosing a random position for each wire within each segment. Sun *et al.* develop a similar method called the Random Displacement Spline Interpolation (RDSI) method that also allows for smooth variation of the position of the wires from one segment to another [7]. The need by both methods to numerical solve many harness configurations requires significant computational effort.

Another method for dealing with the statistical variation of crosstalk that promises to significantly reduce computational effort was proposed by Bellan and Pignari [8]. The method estimates the statistical variation of crosstalk using lumped 2-wire models for crosstalk and the statistical variation of inductance or capacitance within a single harness cross-section. This method works well at low frequencies (e.g. 1 kHz), where weak-coupling may be assumed. This work was extended in [9], where simplifying limits were



proposed to estimate the reasonable worst-case crosstalk (e.g. the worst crosstalk that will occur in 99% of configurations) at frequencies where weak-coupling no longer applies.

Here, the aim is to further extend the work in [8], [9] to develop closed-form estimates of the statistically reasonable worst-case crosstalk when the harness is electrically small but weak coupling cannot be assumed and demonstrate the applicability of the model over a wide frequency range. The following paragraphs will explain the theory behind the approach and will show the ability of the method to predict the reasonable worst-case crosstalk through comparison to simulations using the RDSI method. Multiple harness configurations will be explored, including large and small termination impedances, the use of return wires, and the influence of bundle height above the return plane and the number of wires in the harness.

## **1.2. ESTIMATION OF VARIATION OF INDUCTANCE AND CAPACITANCE**

Lumped element models can be used to estimate crosstalk at low frequencies, where circuits are electrically small, given the self- and mutual- inductance and capacitance among circuits. Estimation of crosstalk in harnesses is difficult because the position of a wire within the harness is often unknown, the position changes along the wire length (often associated with bundle “twist”), and the influence of other wires in the harness cannot necessarily be ignored when calculating crosstalk between a particular culprit and victim.

A common method for dealing with the random position of wires within the harness is to calculate values of inductance and capacitance for a specific, fixed harness cross-section, to assume this cross-section reasonably approximates any cross-section of the harness, and to account for twist by splitting the harness into segment and giving circuits a new, random position within each segment [6-8]. Crosstalk is calculated from the inductance and capacitance parameters of the harness segments. The rate that wires change along the length of the wire (i.e. the amount of twist) is controlled by the number of segments. Here, that same approach is used to first estimate the statistical variation of

the self- and mutual- inductance and capacitance within the harness and then to estimate the crosstalk between harness circuits.

An example bundle cross-section used in this study is shown in Figure 1.1. This bundle consists of 14 20-gauge copper wires separated by the thickness of the PVC insulation, which was set equal to the radius of the wires. The height of the center of the bundle from the return plane was typically 2 cm, though experiments were also performed with the harness lying directly on the return plane. Matrices [10] describing the per-unit-length self- and mutual-inductances within the harness cross-section were found using the 2D electromagnetic modeling tool Ansoft Maxwell 2D Extractor. Here, the tool calculated Maxwell matrices rather than SPICE-type matrices. The wire for a particular circuit was assumed to take on any position within the harness with equal probability. To simplify analysis, position of a wire within one harness segment was assumed to be independent of its position in any other segment.

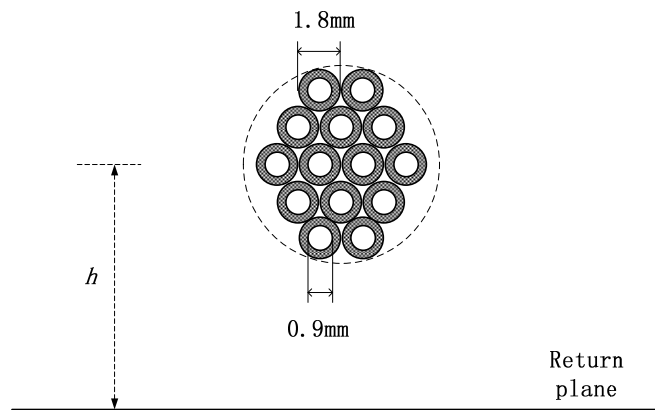

Figure 1.1. Cross section of a 14 wire harness

The statistical distribution of the per-unit-length inductance or capacitance from one wire within the harness to any other wire or to the return plane can be determined from the inductance and capacitance matrices calculated using a 2D modeling tool. The probability distribution for self inductance with respect to the return plane is found from the number of occurrences of a value along the main diagonal of the inductance matrix. The probability distribution for mutual inductance is found from the upper-triangle of the

matrix. Probability distributions for self- and mutual- capacitance can be found in a similar manner.

Crosstalk is calculated from the average per-unit-length inductance and capacitance along the harness and from the harness length. The average per-unit-length inductance or capacitance is a weighted sum of the per-unit-length inductance or capacitance for each segment. Since these are random quantities, the average per-unit-length inductance or capacitance is given by a weighted sum of random variables. As each random variable is independent and has the same probability distribution, say  $f_s(x)$ , the probability distribution for the average per-unit-length inductance or capacitance for the harness, say  $f_h(x)$ , is given by a convolution of probability distributions among the segments. For example, for two segments of equal length, the average per-unit-length inductance or capacitance of the harness is given by [11]:

$$f_h(x) = \int_{-\infty}^{\infty} f_s(2x - y)f_s(y)dy. \quad (1)$$

More than two segments would require a series of similar convolutions.

Typical probability distributions generated using this technique are illustrated in Figure 1.2 through 1.5. Plots were generated using the harness cross-section shown in Figure 1.1 with 14 wires and a height,  $h$ , of 2 cm above the return plane. Figure 1.2 shows the probability distribution for the per-unit-length mutual inductance generated from the upper triangle of the inductance matrix. Figure 1.3 shows the probability distribution for the average or “effective” per-unit-length mutual inductance over the entire harness after breaking the harness into 8, 16, or 32 segments and assuming a new, random position of each wire for each segment. The nearly-uniform nature of the probability distribution for a single segment causes the probability distribution for multiple segments to get progressively narrower as the number of segments increases. Figs 4 and 5 show the probability distribution for the per-unit-length mutual capacitance for a single segment and for 8, 16, and 32 segments. In this case, the probability distribution for a single segment is asymmetrical, as very small values of mutual capacitance are much more likely than large values, and the probability distribution envelope becomes wider and the median value moves to the right (to larger values of capacitance) as additional segments are added.

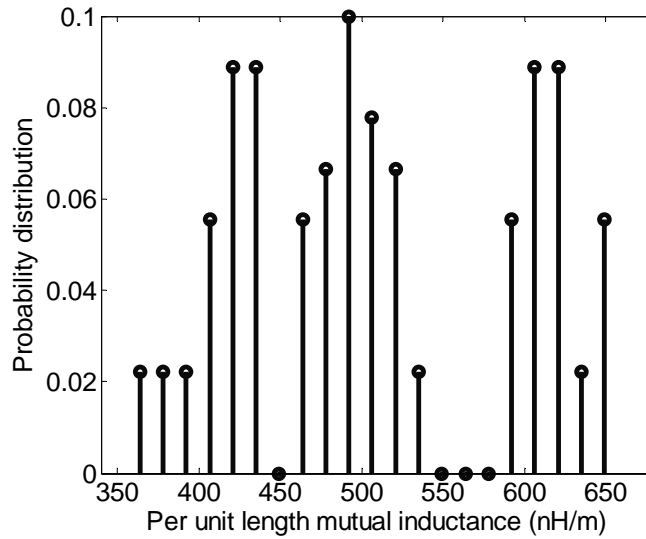

Figure 1.2. Probability distribution for per-unit-length mutual inductance in wiring harness containing 14 20-gauge wires 2 cm above a return plane

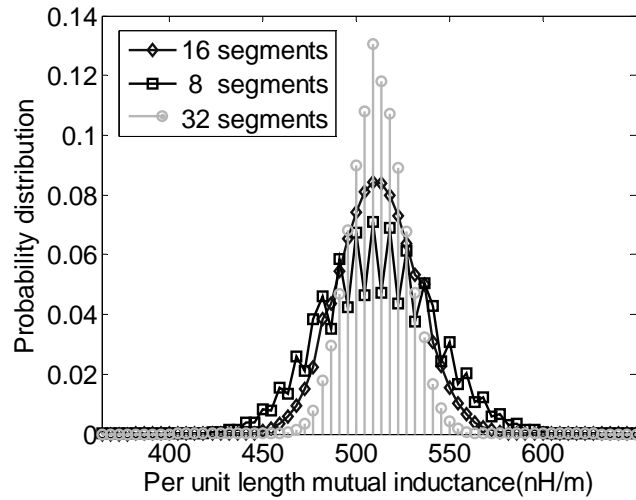

Figure 1.3. Probability distribution of "effective" per-unit-length mutual inductance for wiring harness containing 14 20-gauge wires 2 cm above a return plane

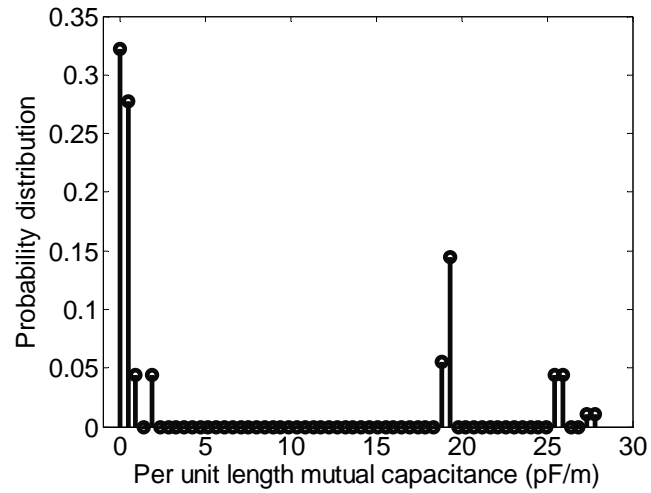

Figure 1.4. Probability distribution of per-unit-length mutual capacitance for a single segment of a harness containing 14 20-gauge wires 2 cm above a return plane

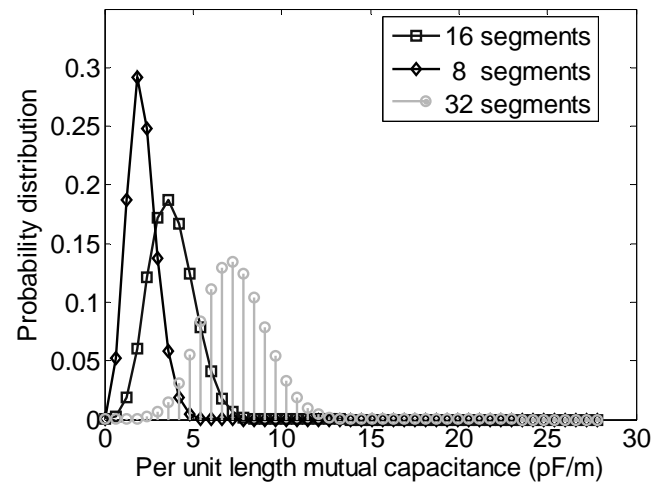

Figure 1.5. Probability distribution of the "effective" per unit length mutual capacitance for a wiring harness containing 14 20-gauge wires 2 cm above a return plane

### 1.3. ESTIMATION OF “REASONABLE WORST-CASE” CROSSTALK

At low frequencies where coupling is weak, crosstalk can be estimated using simple lumped-element equations with information about only the culprit and victim circuits and the mutual inductance or capacitance between them [8], [9]. A model for crosstalk in this case is shown in Figure 1.6. The far-end inductive crosstalk is given by

$$xtalk_{ind} = \frac{V_{FE\_IND}}{V_S} = -\frac{j\omega L_m R_{FE}}{(R_S + R_L)(R_{NE} + R_{FE})} \quad (2)$$

and capacitive crosstalk by

$$xtalk_{cap} = \frac{V_{FE\_CAP}}{V_S} = \frac{j\omega C_m R_L R_{NE} R_{FE}}{(R_S + R_L)(R_{NE} + R_{FE})}, \quad (3)$$

where crosstalk is defined as the ratio of the voltage across the load of the victim circuit to the culprit source voltage. Worst-case crosstalk among harness configurations can be estimated from the largest value of mutual capacitance or inductance, though this value of crosstalk may occur only very rarely. “Reasonable” worst-case crosstalk can be estimated from the largest values of mutual inductance or capacitance that will occur over a percentage of harness configurations. For example, for the case shown in Figure 1.3, the worst-case value of per-unit-length mutual inductance is about 650 nH/m; yet, in more than 99% of configurations, the worst effective mutual inductance over the length of the harness is less than 570 nH/m when wires change position 32 times over the harness length. A statistically reasonable estimate of worst-case inductive crosstalk (i.e. worst crosstalk in 99% of configurations) could be found using a mutual inductance of 570 nH/m in crosstalk calculations.

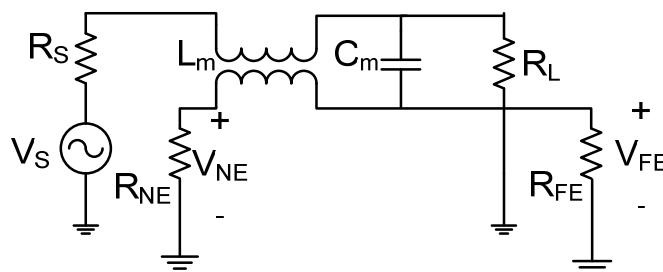

Figure 1.6. Low-frequency model for crosstalk

At higher frequencies, the weak coupling assumption breaks down and the influence of the other circuits must be taken into account [9]. The crosstalk due to inductive coupling in this case can be approximated by lumping all the potential victim circuits together as shown in Figure 1.7. This approximation is valid assuming that a) that the magnetic flux produced by the culprit circuit will generate approximately the same voltage drop across all other (victim) circuits in the harness, i.e. they share approximately the same mutual inductance,  $M$ , b) that the net magnetic flux produced by the induced current in the victim circuits will generate approximately the same voltage drop across all victim circuits, as represented by the self inductance  $L_{\text{harness}}$ , and c) that the net magnetic flux produced by the victim circuits will generate a voltage drop across the culprit circuit that may also be represented by the mutual inductance  $M$ . These approximations are reasonable so long as the current return path (e.g. the return plane) is reasonably far from the wires in the harness, so that all values of mutual and self inductance are relatively close. Using these assumptions, the voltage drops created by magnetic flux through the victim circuits can be lumped together as a single self - or mutual-inductance for all the victim circuits, as shown in the figure, resulting in a relatively simple circuit for approximating the crosstalk that accounts for strong coupling within the harness. In this case, the far-end inductive-crosstalk in the victim of interest (circuit # 2) is given approximately by

$$xtalk_{ind} \approx -\frac{R_{FE2}}{R_{NE2} + R_{FE2}} \times \frac{j\omega M Z}{(\omega M)^2 + (R_s + R_L + j\omega L_1)(Z + j\omega L_{\text{harness}})} \quad (4)$$

where  $Z$  is the effective impedance of the victim circuits,

$$Z = (R_{NE2} + R_{FE2}) \parallel (R_{NE3} + R_{FE3}) \parallel \dots \parallel (R_{NEN} + R_{FEN}),$$

$M$  is calculated from the net per-unit-length mutual inductance along the harness,  $M = l_m * \text{length}$ , where  $l_m$  is the per-unit-length mutual inductance between the culprit and victim circuits and  $\text{length}$  is the length of the harness,  $L_1$  is approximated from the average per-unit-length self inductance of all the circuits in the harness,  $L_1 = l_{s\_avg} * \text{length}$ , where  $l_{s\_avg}$  is calculated from the average value of the main diagonal of the inductance

matrix. The self inductance of the harness,  $L_{\text{harness}}$ , can be approximated by the mutual inductance,  $M$ .

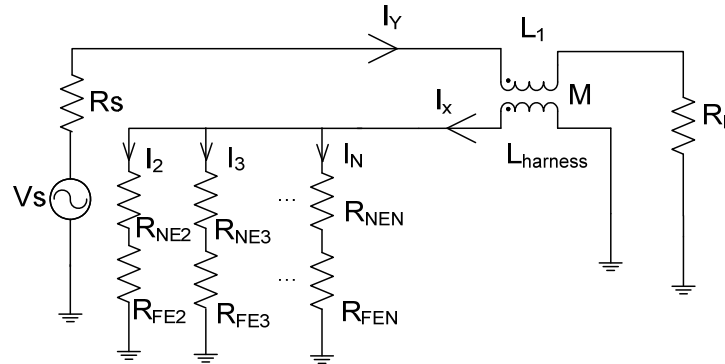

Figure 1.7. Circuit model approximating strong inductive coupling

A similar approximation can be made for capacitive coupling when weak coupling cannot be assumed. The victim circuits are again lumped together as shown in Figure 1.8. The model shows the mutual capacitance from the culprit to the victim of interest (represented by resistance  $R_{RE2}/R_{FE2}$ ) and also represents the capacitive coupling from the culprit to all other circuits in the harness (whose impedance is represented by the impedance  $Z_{all} = R_{NE2} // R_{FE2} // \dots // R_{NEN} // R_{FEN}$ ) and the capacitive coupling from the victim of interest to all other circuits in the harness. The capacitive coupling to all other circuits in the harness is represented by  $C_x = C_{o\_avg} - C_m$ , where  $C_m$  is calculated from the per-unit-length mutual capacitance as found from the capacitance matrix,  $C_m = c_m * length$ , and  $C_{o\_avg}$  is calculated from the average per-unit-length value of capacitance given on the main diagonal of the (Maxwell) capacitance matrix and approximates the sum of all capacitance values from a wire to all other wires in the harness and to the return plane. The capacitance to the return plane is assumed to be small compared to other values of capacitance and is ignored in this approximation. Based on this model, the far-end capacitive crosstalk in the victim of interest (circuit # 2) is approximately



$$\begin{aligned}
 xtalk_{cap} \approx & \frac{Z_x}{(R_S + Z_x + j\omega L_1)} \\
 & \times \frac{[j\omega(C_x + 2C_m) + \frac{C_m}{C_{o\_avg} Z_{all}}]}{(\frac{1}{Z_{all}} + 2j\omega C_x)(1 + \frac{1}{j\omega C_x \cdot R_{NE2} // R_{FE2}} + \frac{C_m}{C_x}) - j\omega C_{o\_avg}}
 \end{aligned} \tag{5}$$

where  $Z_x$  is defined as:

$$Z_x \approx R_L // (\frac{1}{j\omega C_{o\_avg}} + R_{NE2} // R_{FE2} // Z_{all}).$$

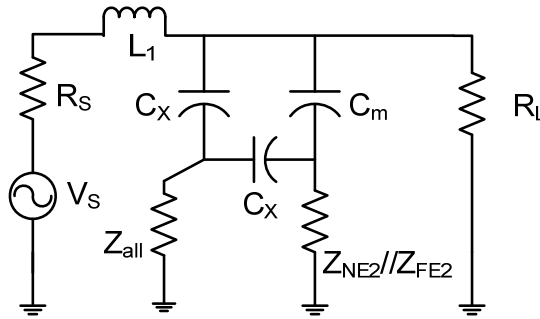

Figure 1.8. Circuit model approximating strong capacitive coupling

The reasonable worst-case inductive or capacitive crosstalk can be estimated from (3) or (4) using the reasonable worst-case values of mutual inductance or capacitance (e.g. using 570 nH/m for the configuration in Figure 1.3).

Using these values allows one to calculate the reasonable worst-case crosstalk due to either inductive or capacitive coupling, but not necessarily due to both, since large values of mutual capacitance may not occur for the same configurations that cause large values of mutual inductance. Since the joint relationship between inductive and capacitive coupling is complicated, and typically either one or the other dominates, a simple heuristic was used here to approximate the total crosstalk. At the near-end, where inductive and capacitive crosstalk are in-phase, the total crosstalk was approximated as the sum of crosstalk calculated using (3) and (4). At the far-end, where inductive and capacitive crosstalk are out-of-phase, the total crosstalk was approximated as the larger of

(3) and (4). This approximation may overestimate crosstalk when inductive and capacitive coupling are approximately equal and cancel one-another at the far-end, but should not underestimate crosstalk and should be reasonably close to the correct value in most cases.

#### **1.4. APPLICATION OF THE METHOD**

The proposed method of estimating reasonable worst-case crosstalk was tested by applying it to several test configurations and comparing results to crosstalk calculated using the RDSI algorithm [7]. The RDSI algorithm has previously been shown to produce results that closely match experimental data [7]. Both the RDSI algorithm and the reasonable worst-case estimate were based on the numerical solution of L and C matrices using Ansoft Maxwell 2D Extractor for a harness cross-section like that shown in Figure 1.1. The RDSI algorithm then used Monty Carlo methods and HSPICE simulations to estimate the total crosstalk (inductive + capacitive) for several possible wire position-configurations within the harness. The reasonable worst-case crosstalk was estimated using (3) and (4) as explained above. Each method was configured so that the wires changed position approximately 32 times along the harness length (i.e. 32 segments were used for the reasonable worst-case estimate). The harness was assumed to be 2 m long and lie above a large return plane. Simulations were performed from 10 kHz to 10 MHz, where the harness could be considered electrically small. The number of wires in the harness, the height above the return plane, and the value of source- and load-impedances were varied as indicated in the following test configurations:

- Scenario 1: 3 wires, height = 2 cm, 50 ohm and 1 kohm terminations.
- Scenario 2: 14 wires, height = 2 cm, all terminations 50 ohms;
- Scenario 3: 14 wires, height = 2 cm, all terminations 1 kohm;
- Scenario 4: 14 wires, lying on return plane, all terminations either 50 ohms or all terminations 1 kohm;
- Scenario 5: 14 wires, lying on return plane, terminations varied to mimic realistic harness impedances;

- Scenario 6: 14 wires, lying on return plane, all terminations either 50 ohms or 1 kohm; presence of return wire;

**1.4.1. Scenario 1: 3 wires, height = 2 cm, 50 ohm and 1 kohm terminations.**

In the first scenario tested, the harness had only 3 wires, was 2 cm above the return plane, and was loaded on both ends with either 50-ohm loads – and inductive coupling dominated - or 1-kohm loads – and capacitive coupling dominated. Under these configurations, the variation in crosstalk among harness instantiations is small and results should be very close to analytic calculations. As expected, the reasonable worst-case estimate (as well as the RDSI estimate) was within 1 dB of the analytic estimate across the entire frequency range, verifying the technique works well even for a small number of wires.

**1.4.2. Scenario 2: 14 wires, height = 2 cm, all terminations 50 ohms.** For this configuration, inductive coupling should dominate, since the termination impedances are relatively low. The reasonable worst-case crosstalk and the crosstalk predicted by 273 RDSI simulations of random harness instantiations are shown in Figure 1.9 for the near-end crosstalk and Figure 1.10 for the far-end crosstalk. The reasonable worst case estimate is within about 5 dB of the worst crosstalk found by the RDSI algorithm.

**1.4.3. Scenario 3: 14 wires, height = 2 cm, all terminations 1 kohm.** In this scenario, capacitive coupling should dominate. The near- and far-end crosstalk are shown in Figure 1.11 and 1.12, respectively. The reasonable worst-case estimate was within about 5 dB of the worst value found using the RDSI algorithm.

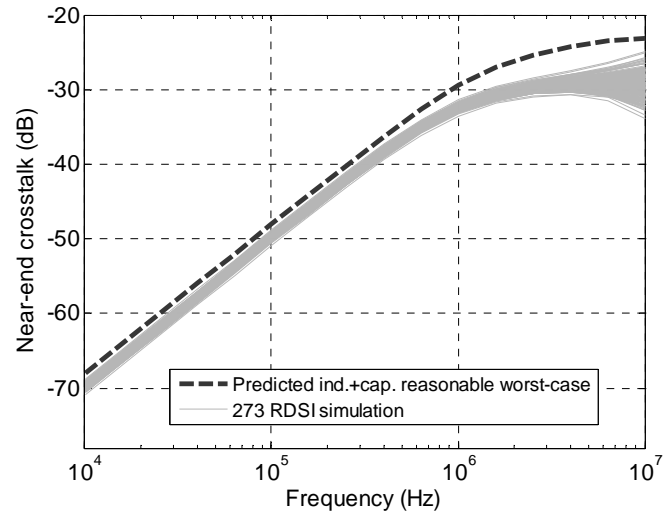

Figure 1.9. Near-end crosstalk when all circuits were loaded with 50 ohms

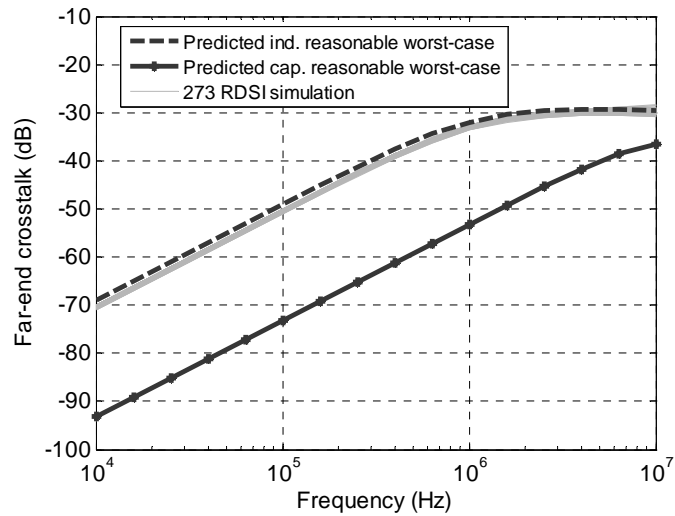

Figure 1.10. Far-end crosstalk when all circuits were loaded with 50 ohms

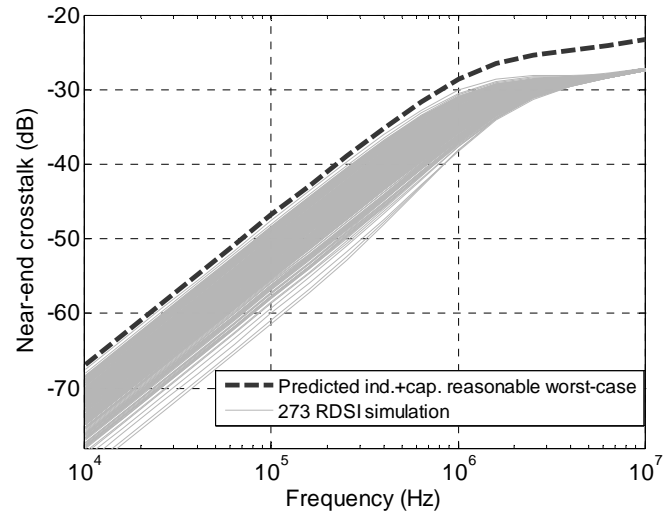

Figure 1.11. Near-end crosstalk when all circuits were loaded with 1 kohm

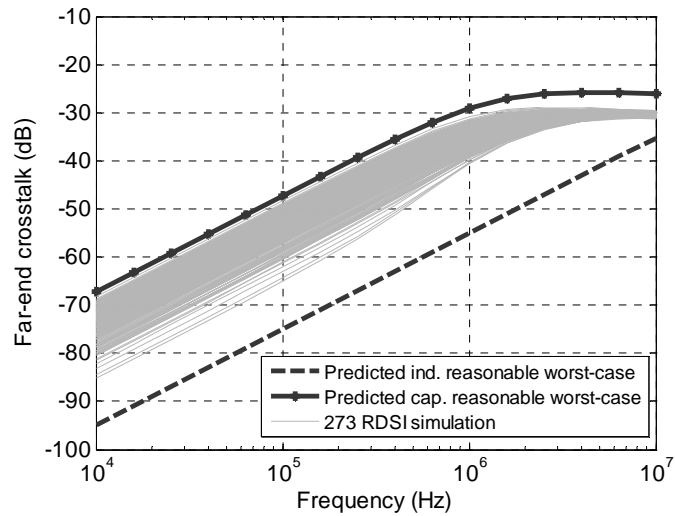

Figure 1.12. Far-end crosstalk when all circuits were loaded with 1 kohm

**1.4.4. Scenario 4: 14 wires, lying on return plane, all terminations either 50 ohms or all terminations 1 kohm.** To study the ability to estimate reasonable worst-case crosstalk for small heights, simulations were performed with the harness lying directly on the return plane. This case is expected to be challenging for the proposed estimation method since the variation of inductive coupling should be much larger and the application of some approximations used by the estimate may not be as appropriate as when the harness is far from the return plane. Estimates of crosstalk are shown in Figure 1.13 when all terminations were 50 ohms and in Figure 1.14 when all terminations were 1 kohm. The reasonable worst-case estimate was within a few decibels of the worst-case estimated using RDSI for both termination conditions.

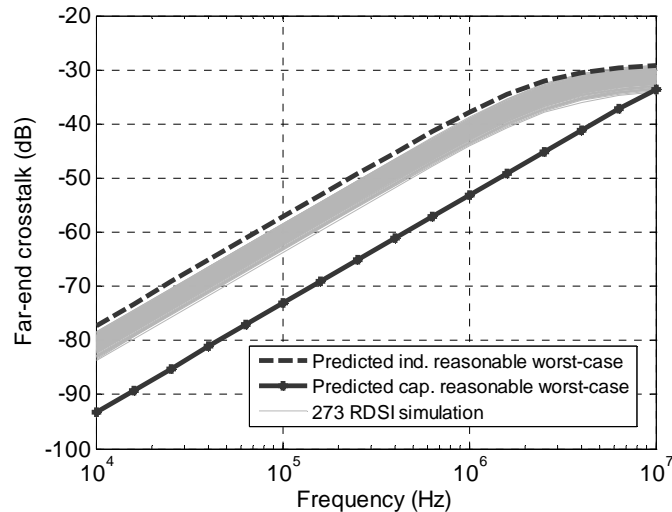

Figure 1.13. Far-end crosstalk when the bundle was lying on the return plane and all circuits were loaded with 50 ohms

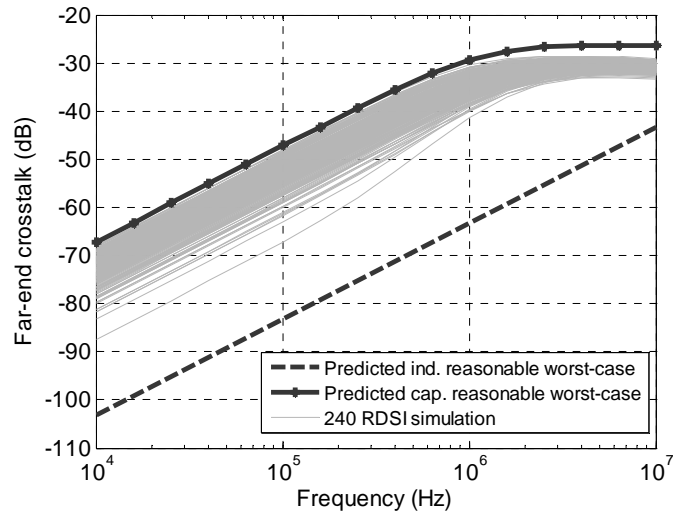

Figure 1.14. Far-end crosstalk when the bundle was lying on the return plane and all circuits were loaded with 1 kohm

Table 1.1. Near-end and far-end loads

Circuit #	$R_{NE}$	$R_{FE}$	Circuit #	$R_{NE}$	$R_{FE}$
1	2 k $\Omega$	2 k $\Omega$	8	10 $\Omega$	1 k $\Omega$
2	10 $\Omega$	100 $\Omega$	9	15 k $\Omega$	10 $\Omega$
3	100 k $\Omega$	10 $\Omega$	10	47 $\Omega$	10 $\Omega$
4	47 $\Omega$	100 k $\Omega$	11	1 k $\Omega$	10 $\Omega$
5	1 k $\Omega$	47 $\Omega$	12	10 $\Omega$	1 k $\Omega$
6	100 k $\Omega$	15 k $\Omega$	13	10 $\Omega$	15 k $\Omega$
7	15 k $\Omega$	15 k $\Omega$	14	47 $\Omega$	47 $\Omega$

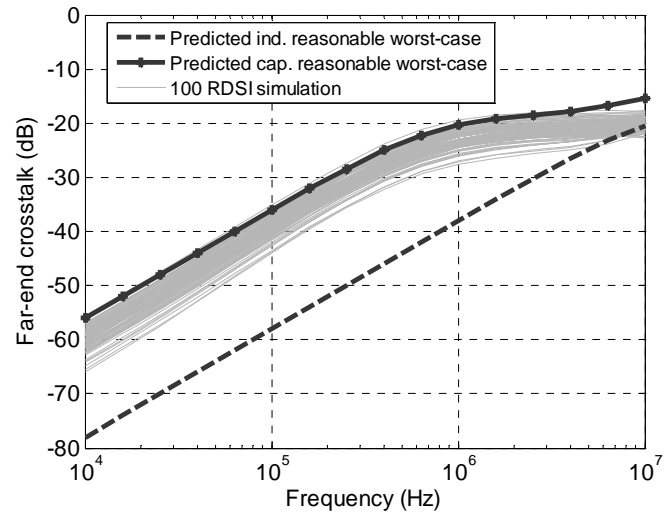

Figure 1.15. Far-end crosstalk from circuit 2 to circuit 1 when the bundle was loaded as shown in Table 1.1

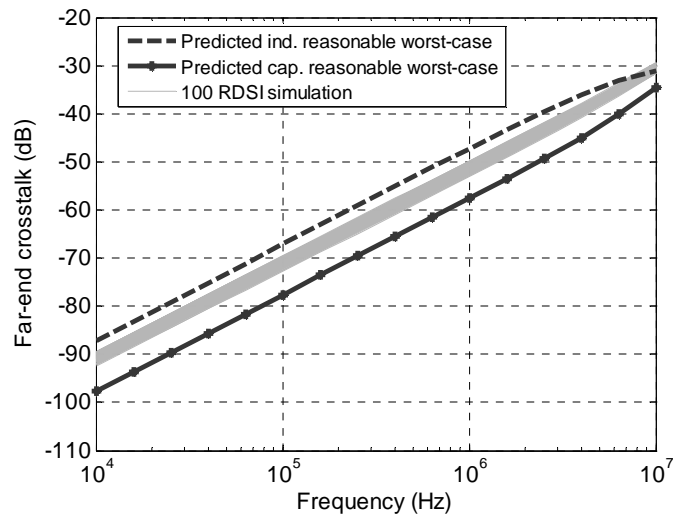

Figure 1.16. Far-end crosstalk from circuit 2 to circuit 10 when the bundle was loaded as shown in Table 1.1



**1.4.5. Scenario 5: 14 wires, lying on return plane, terminations varied to mimic realistic harness impedances.** In this case, the harness was terminated with a variety of impedances as shown in Table 1. These terminations are similar to those used by others in the study of the statistical characteristics of harness crosstalk [1-2], [6-7]. The first experiments used circuit 2, with relatively small termination impedances (10 ohms and 100 ohms), as the culprit and used circuit 1, with relatively large termination impedances (2 kohms), and circuit 10, with relatively small impedances (47 ohms and 10 ohms), as the victims. Far-end crosstalk is shown in Figure 1.15 when circuit 1 was the victim and in Figure 1.16 when circuit 10 was the victim. The reasonable worst-case estimate was within about 3 dB of the worst crosstalk found using RDSI in these cases.

The second experiments used circuit 1, with a relatively large termination impedance (2 kohms), as the culprit and circuit 2, with a relatively small termination impedance (10 ohms and 100 ohms), and circuit 7, with a relatively large termination impedance (15 kohms), as the victims. The far-end crosstalk for these configurations is shown in Figure 1.17 and 1.18. The reasonable worst-case estimate of crosstalk to circuit 7 was within a few decibels of the worst crosstalk found by the RDSI algorithm over the frequency range studied. The reasonable worst-case over-estimated the worst crosstalk to circuit 1, however, by about 10 dB below 1 MHz. This overestimation results because neither inductive nor capacitive coupling dominates for this configuration and the two cancel each out at the far end, resulting in lower crosstalk than is found with either inductive or capacitive crosstalk alone.

**1.4.6. Scenario 6: 14 wires, lying on return plane, all terminations either 50 ohms or 1 kohm; presence of return wire.** Another case that is expected to be challenging for the proposed estimation technique is the case where a return wire exists within the harness. This case is challenging since high-frequency current will return over this wire rather than the return plane and some approximations may not be as appropriate as when currents return far from the harness. To perform this estimation, the extraction of the L and C matrices was performed such that one wire in the harness was designated as a return wire and was lumped with the return plane in the 2D extraction tool, so the return plane and return wire were treated as the same conductor. Thus, for the harness shown in Figure 1.1, the harness included 13 wires associated with circuits and 1 wire for the return, and the L and C matrices contained 13 rows and columns. Other estimation steps were performed as before. Estimated crosstalk is shown in Figure 1.19 when all circuits were terminated with 50 ohms and in Figure 1.20 when all circuits were terminated with 1 kohm. The reasonable worst case was within a few decibels of the worst case found with the RDSI algorithm. Simulations where the harness was 2 cm above the return plane were also performed with slightly better results than when the harness was lying on the return plane.

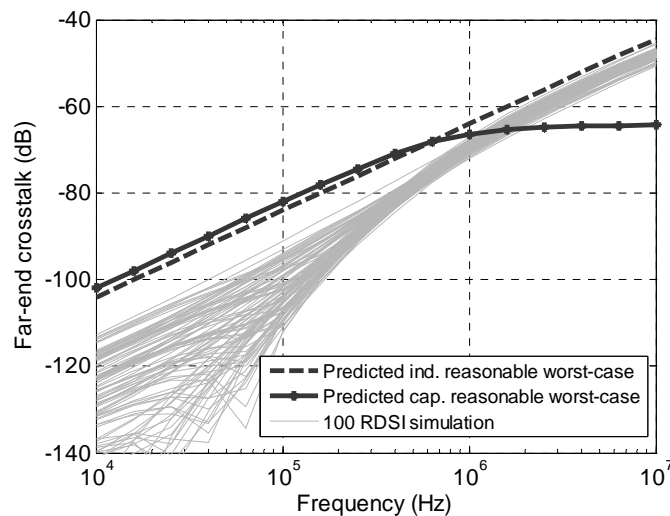

Figure 1.17. Far-end crosstalk from circuit 1 to circuit 2 when the bundle was loaded as shown in Table 1.1

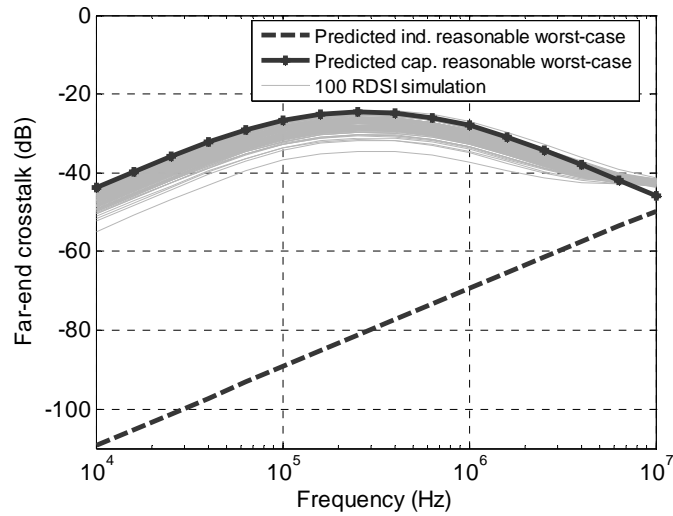

Figure 1.18. Far-end crosstalk from circuit 1 to circuit 7 when the bundle was loaded as shown in Table 1.1

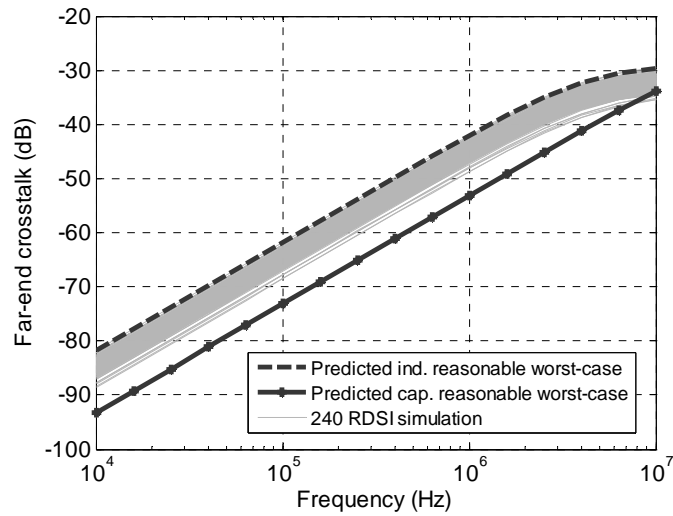

Figure 1.19. Far-end crosstalk when the bundle was lying on the return plane and all wires were loaded with 50 ohms except a return wire

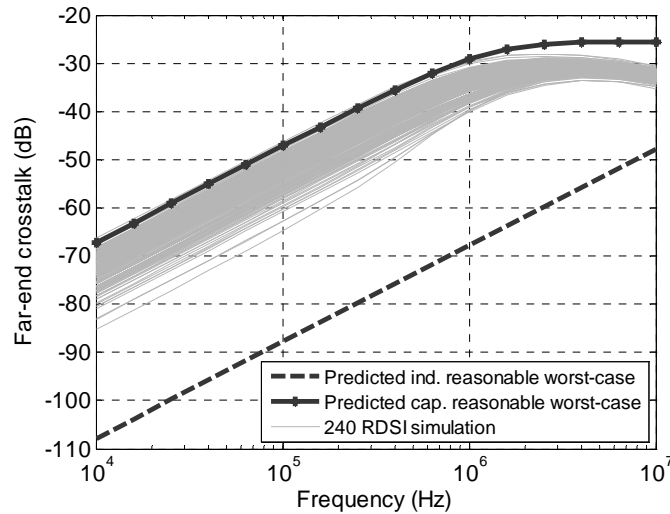

Figure 1.20. Far-end crosstalk when the bundle was lying on the return plane and all wires were loaded with 1 kohm except a return wire

## 1.5. DISCUSSION

The proposed method of estimating the reasonable worst-case crosstalk successfully bound the worst crosstalk found through multiple RDSI simulations within 5 dB or less for all the scenarios tested. While only resistive loads were explored, good results are also expected with reactive loads, since they do not make a fundamental change to the algorithm. For similar reasons, good results are also expected for larger bundle sizes or larger distances above the return plane.

The estimate of the rate that wires change within the harness has a direct impact on the estimate of the reasonable worst-case crosstalk. The rate that wires change position is modeled here by the number of segments used to estimate the probability distribution for inductance or capacitance. As shown in Figure 1.3 and 1.4, using 8 segments rather than 32 segments results in a reasonable worst-case mutual inductance of about 600 nH/m rather than 570 nH/m and a mutual capacitance of about 5 pF/m rather than 13 pF/m. Mis-estimating the rate that wires change position could result in a larger or smaller estimate of the reasonable worst-case crosstalk than occurs in the actual harness.

This mis-estimation would occur with either the proposed method or using the RDSI or similar algorithms.

It is challenging to estimate the reasonable worst-case crosstalk using the proposed method when inductive and capacitive coupling are out-of-phase and approximately equal in size, as occurred in Figure 1.17. The current technique will overestimate crosstalk in these scenarios since it cannot accurately predict the value of both inductive and capacitive crosstalk for *specific* configurations. Accurate estimation requires formation of a joint probability distribution between inductance and capacitance so that reasonable levels of cancellation can be predicted. Development of this method is left for future work. The current method, however, can be considered a conservative estimate when inductive and capacitive coupling contribute nearly equally to far-end crosstalk.

Here, the variation in crosstalk due to only the change in wire positions was studied. In real harnesses, the height of the harness also varies randomly above the return plane as does the compactness of the harness. The proposed technique might be extended to account for these conditions by calculating L and C matrices for a representative sample of possible heights or compactness, attributing a given probability to each condition, and then using this information to calculate a probability distribution for inductance and capacitance as shown in Figure 1.3 and 1.4. Once these probability distributions are known, the reasonable worst-case crosstalk can be found using (3) or (4).

## 1.6. CONCLUSION

The proposed method does a good job of estimating the reasonable worst-case crosstalk due to random variation of wire position within cable bundles. The advantage of the technique is not only improved estimation speed, but the potential to improve the understanding of why problems occur and how to fix them, since results are found from relatively simple closed form approximations and L and C matrices. Accurate prediction depends on accurate knowledge of harness parameters, like harness height or the rate that wires change position along the harness length. While random variation in harness height

or other parameters were not dealt with here, the technique might also be extended to account for these variations.

## REFERENCES

- [1] G. Capraro and C.R. Paul, "A probabilistic approach to wire coupling interference prediction," *Proceedings of the 1981 IEEE International Symposium on EMC, Zurich*, 1981
- [2] C.R. Paul, "Sensitivity of crosstalk to variations in cable bundles," *Proceedings of the 1987 IEEE International Symposium on EMC, Zurich*, 1987.
- [3] D. G. Beetner, H. Weng, M. Wu, T. Hubing, "Validation of worst-case and statistical models for an automotive EMC expert system," *2007 IEEE International Symposium on Electromagnetic Compatibility*, pp. 1-5, July 2007.
- [4] W.T. Smith, C.R. Paul, J.S. Savage, S.K. Das, A.D. Cooperider, and R.K. Frazier, "Crosstalk modeling for automotive harnesses," *1994 IEEE International Symposium on Electromagnetic Compatibility*, pp. 447-452, Aug. 1994.
- [5] S. Shiran, B. Reiser, and H. Cory, "A probabilistic model for the evaluation of coupling between transmission lines," *IEEE Transactions on Electromagnetic Compatibility*, vol. 35, no. 3, pp. 387-393, 1993.
- [6] A. Ciccolella and F.G. Canavero, "Stochastic prediction of wire coupling interference," *Proceedings of the 1995 IEEE International Symposium on EMC*, pp. 51-56, 1995.
- [7] S. Sun, G. Liu, J. Drewniak, and D. Pommerenke, "Hand-Assembled Cable Bundle Modeling for Crosstalk and Common-Mode Radiation Prediction," *IEEE Transactions on Electromagnetic Compatibility*, vol. 49, no. 3, pp. 708-18, Aug. 2007.
- [8] D. Bellan and S. A. Pignari, "Estimation of Crosstalk in Nonuniform Cable Bundles," in *Proc. 2005 IEEE Int. Symp. on Electromagn. Compat.*, Chicago, IL, USA, Aug. 8-12, 2005, pp. 336-341.
- [9] M. Wu, D. Beetner, T. Hubing, "Estimation of the statistical variation of crosstalk in wiring harnesses," *IEEE Int. Symp. on EMC*, August 2008
- [10] C.R. Paul, *Analysis of multiconductor transmission lines*. NJ: John Wiley & Sons, 1994, pp. 71.

- [11] A. Papoulis, S. Unnikrishna Pillai. Probability, random variables and stochastic processes with errata sheet, 4<sup>th</sup> edition. New York: McGraw Hill Higher Education, 2002.



## **2. IMPROVING CROSSTALK SIMULATION SPEEDS FOR CABLE HARNESS BUNDLES USING THE T-PARAMETER METHOD**

Meilin Wu, Daryl G. Beetner, Jun Fan, Todd Hubing, Haixin Ke

### **ABSTRACT**

Statistical variations in crosstalk are typically characterized using Monte Carlo simulation techniques which require significant computational effort due to the many random instantiations of the circuit that must be evaluated to obtain an accurate result. Depending on the circuit, simulations may take days to complete. This paper proposes the use of T-parameter (Transfer parameter) matrices to improve the speed of Monte Carlo simulations of cable harness bundles. In this method, a reference S-parameter matrix is estimated for a single harness cross-section. Random variation in wire positions are represented by swapping rows and columns of the S-parameter matrix. Variation of position along the harness length is performed by segmenting the harness and representing each segment with a different S-parameter matrix. The T-parameter matrix representing the overall harness is found by multiplying the T-parameter matrices for each segment, which can be obtained from their corresponding S-parameter matrices. Simulations using the T-parameter method and using SPICE shows both methods give the same answer but the T-parameter method is more than 200 times faster.

### **2.1 INTRODUCTION**

Crosstalk in cable bundles varies because of the random placement of wires within the bundle, as well as due to other random variations like the height of the bundle above a return plane or the variation of load impedances. Estimation of the statistical variation of crosstalk is used to help prevent over design while ensuring that any problems that are likely to occur will be solved. Although methods exist to estimate

bounds for the statistical variation of crosstalk with minimal simulations [1], [2], statistical variation is typically characterized using Monte Carlo methods.

Monte Carlo methods require the cable bundle to be constructed for many random instantiations of the bundle and a simulation to be performed for each instantiation. Several methods of performing the simulation exist. The method used by S. Sun et al. generates a circuit model for the harness and then uses a SPICE tool to find crosstalk [3]. Harness models are generated by splitting the harness into several segments, where wire position is constant for each segment but changes between segments. Depending on the technique, wires may change position abruptly between segments or may change slowly along the harness length [2][3]. To characterize statistical variations, many SPICE decks must be generated and then simulated. Cicceleva and Canavero [4] perform a similar simulation by solving multi-conductor transmission line equations. The many simulations performed by either of these methods are computationally and time consuming.

As an alternative to existing simulation techniques, the cable bundle can be represented using a transfer-parameter (T-parameter) matrix. The technique will yield the same results as a SPICE solver or as multi-conductor transmission line equations when wire segments are electrically small but the matrices can be easily manipulated to account for variations in wire position and can be solved very quickly. These characteristics give the T-parameter method a speed advantage over existing simulation methods, as will be demonstrated in the following paper.

## 2.2 THE T-PARAMETER MATRIX

The T-parameter matrix is defined for a multi-port network as shown in Figure 2.1, where “inputs” to the network are shown on the left and “outputs” are shown on the right. An incident wave,  $a_i$ , and reflected wave,  $b_i$ , is defined for each port,  $i$ . The T-parameter matrix relates the inputs and outputs as [5]:

$$\begin{bmatrix} a_1 \\ \vdots \\ a_n \\ b_1 \\ \vdots \\ b_n \end{bmatrix} = [T]_{2n \times 2n} \begin{bmatrix} b_{n+1} \\ \vdots \\ b_{2n} \\ a_{n+1} \\ \vdots \\ a_{2n} \end{bmatrix}. \quad (1)$$

Since the T-parameter matrix and scattering-parameter (S-parameter) matrix are both defined for waves entering and leaving a multi-port network, knowledge of one matrix can be used to calculate the other [5]. The T-parameter matrix is particularly well suited for analysis of cascaded networks. For example, the overall T-parameter matrix representing  $x$  cascaded networks with the same number of ports as shown in Figure 2.2, can be calculated by simply multiplying the T-parameter matrices for each network:

$$T_{overall} = T_1 \cdots T_x, \quad (2)$$

where  $T_{overall}$  is the T-parameter matrix of the overall network while  $T_i$  ( $i= 1,2,\dots,x$ ) are the T-parameter matrices representing the cascaded networks.

The transfer characteristics of a cable harness, where wires change position along its length, can be found by splitting the harness into a fixed number of individual segments where wire positions don't change, by finding the S-parameter matrix for a single section for a fixed cross-section of the harness as a reference, by randomly assigning wire positions for each harness segment and then exchanging row and column entries in the calculated S-parameter matrix to correspond with the new wire positions, then calculating the T-parameter matrix for the entire harness by multiplying together the T-parameter matrices for the segments (obtained from S-parameter matrix for each segment). The T-parameter matrix of the entire bundle can then be converted into an admittance matrix to be used along with termination impedances to solve for crosstalk. This procedure will be explained in more detail in the next section.

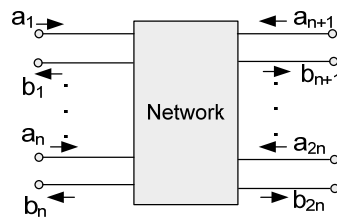

Figure 2.1. Network with  $2n$  ports and the associated incident and reflected waves

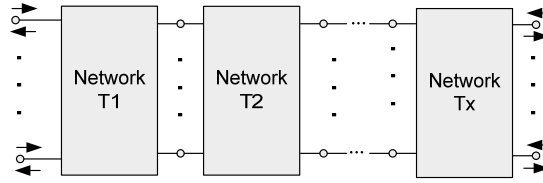

Figure 2.2. An overall network consisting of x cascaded individual networks

## 2.3 CIRCUIT MODEL

Figure 2.3(a) shows a simple circuit model for a 3-wire bundle (without showing the self and mutual capacitances or inductances). Circuit 1 is the culprit circuit and includes an excitation voltage source at its near end. Voltage generated by this excitation source across each of the loads is desired. The voltage source can be converted to a current source with value  $I_s = V_s / R_{ne1}$  as shown in Figure 2.3(b). The circuit can then be split into separate networks connected by ports as shown in Figure 2.4 where the noise voltages of interest become the voltages at the ports. The cable harness is defined as just another network as shown in Figure 2.4(b). For this definition of the harness, crosstalk can be found from the impedance of the loads and the admittance matrix for the harness as:

$$\begin{aligned}
 \begin{bmatrix} V_1 \\ \vdots \\ V_n \\ V_{n+1} \\ \vdots \\ V_{2n} \end{bmatrix}_{2n \times 1} &= \begin{bmatrix} Z_{whole\_network} \end{bmatrix}_{2n \times 2n} \begin{bmatrix} I_1 \\ \vdots \\ I_n \\ I_{n+1} \\ \vdots \\ I_{2n} \end{bmatrix}_{2n \times 1} \\
 &= \left[ \begin{bmatrix} Y_{bundle} \end{bmatrix} + \begin{bmatrix} Z_{load} \end{bmatrix}^{-1} \right]^{-1} \begin{bmatrix} I_1 \\ \vdots \\ I_n \\ I_{n+1} \\ \vdots \\ I_{2n} \end{bmatrix}_{2n \times 1}, \quad (3)
 \end{aligned}$$



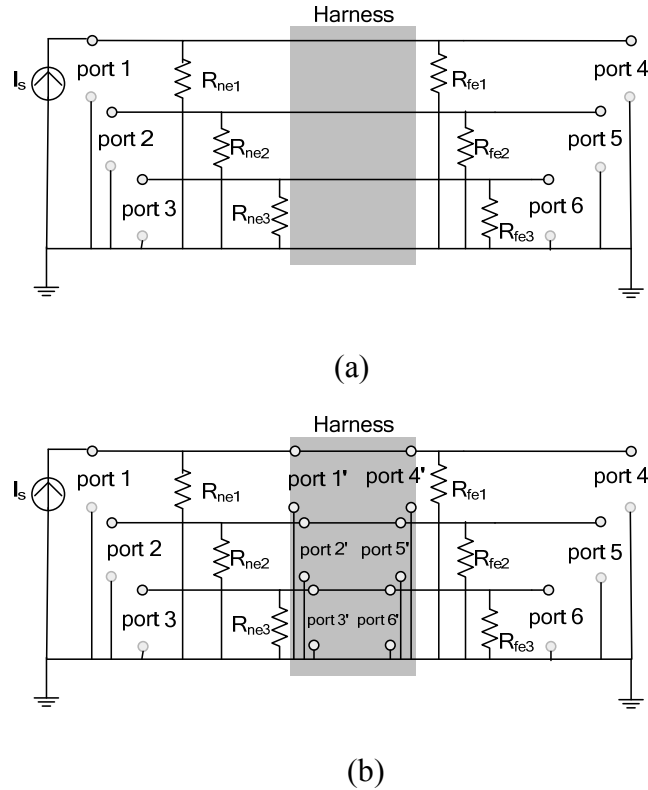

Figure 2.4. The model for the cable bundle shown in Figure 2.3 with defined ports

## 2.4 OBTAINING THE ADMITTANCE MATRIX

As discussed earlier, changes in wire position along the harness can be modeled using abrupt changes from one segment to another, where wire position in one segment is assumed to be independent of position in any other segment, or using smooth changes that model the smooth variation in wire position along the harness length [2][3]. In either case, the bundle can be modeled as a cascade of ideal multi-conductor transmission line segments where wire positions do not change within any one segment. The T-parameter matrix of the entire bundle can be obtained by multiplying the T-parameter matrices for the segments together as shown in equation (2). The resulting T-parameter matrix can then be converted to a Y-parameter matrix to solve (3).

The S-parameter matrix for a single harness segment can be easily obtained using HSPICE provided the per-unit-length RLGC parameters for the segment, which can be

obtained by modeling tools such as Ansoft Maxwell 2D extractor or calculation. If one assumes the harness cross-section is constant along the harness length and the circuits only change positions within this cross-section [2], [3], then S-parameter matrices for the segments may be found simply by swapping rows and columns of the calculated S-parameter matrix, as the only difference between the first segment and the other segments are the wire positions [2]. The S-parameter matrix for the reference cross-section must only be calculated once for a given harness. The S-parameter matrix for each segment can then be converted to a T-parameter matrix and then the T-parameter matrix for the entire harness calculated from the matrices for each segment. Figure 2.5 summarizes one possible flow for the process.

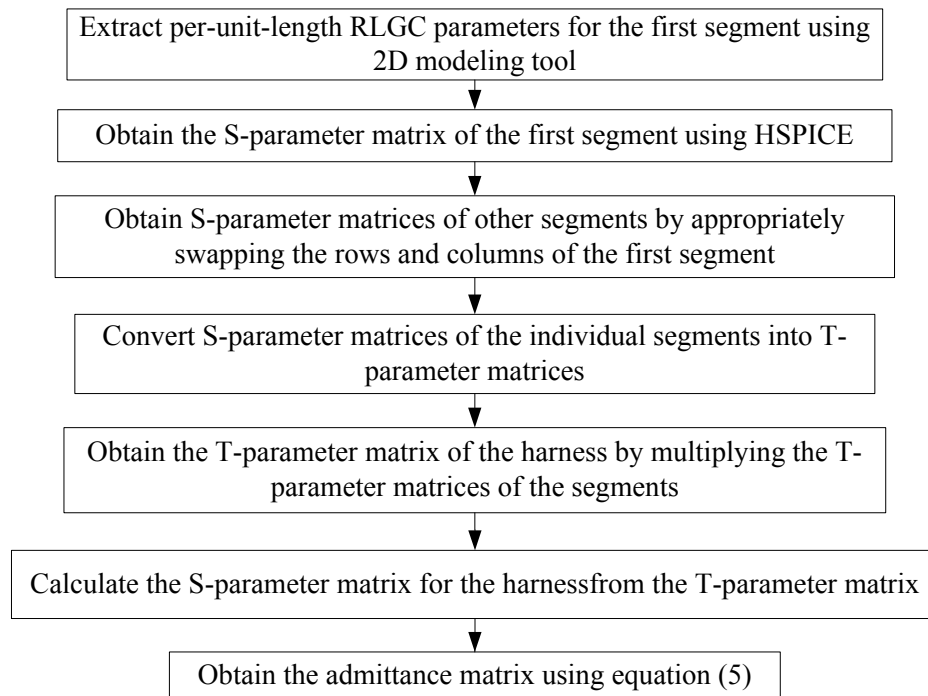

Figure 2.5. An approach for estimating the admittance matrix

## 2.5 PERFORMANCE

To show that the T-parameter method will give the same result as the traditional SPICE method, crosstalk was calculated using both methods for an example wire harness

bundle. A 2-meter long bundle with 14 19-AWG wires 2 cm above a return plane was studied [2]. All 14 wires were loaded with 50 ohms at both ends. The wires were assumed to change position 32-times along the harness length – that is, the variation of wire position was modeled by splitting the harness into 32 independent segments. For this experiment, the position of the wires within each segment was known and fixed. The per-unit-length RLGC parameters for a single reference segment with known cross section was found using Ansoft Maxwell 2D and a corresponding S-parameter matrix was found using HSPICE.

The bundle was first simulated using SPICE. An HSPICE deck was generated using the extracted per-unit-length LC matrices and assuming the wire-harness bundle was lossless for simplicity. The LC matrices were used to construct W or U elements (transmission-line elements in HSPICE) representing the segments of the bundle. Changes in wire position from the reference were modeled by swapping rows and columns of the LC matrices accordingly.

The bundle was simulated next using the T-parameter method. The S-parameter matrix for the reference segment was used as input to a MATLAB script. The script generated S-parameter matrices for segments of the harness by swapping the rows and columns of the reference S-parameter matrix to correspond with wire positions in the harness. The admittance matrix for the harness was then found as shown in Figure 2.5. Crosstalk was then calculated using (3).

Figure 2.6 shows the far-end crosstalk calculated using both methods from circuit 2 (chosen as the culprit circuit in this study) to circuit 1 from 10 kHz to 1 GHz. The T-parameter method generates the same results as SPICE. Similar results were observed in other simulations, verifying the accuracy of the T-parameter method.

The main advantage of the T-parameter method is the potential speed of calculation, since the most complex part of the calculation is the inverse operation performed in (3). Calculation speed of the T-parameter matrix was compared to the speed of simulations using SPICE. Comparison was not performed relative to direct solutions of the multi-conductor transmission line equations as these calculations are reportedly relatively slow [4]. Two MATLAB scripts were used to test the speed of the T-parameter method against the SPICE method. One script used the reference S-parameter matrix to



estimate crosstalk using the T-parameter method. The other script automatically generated an HSPICE deck using the reference LC matrices and called HSPICE to run the deck. For each method, the harness was split into 32 segments and the position of wires were varied randomly between the segments. The same harness configurations were calculated using both the T-parameter method and HSPICE so results could be compared fairly. MATLAB was used to determine the time required to calculate crosstalk for two hundred realizations of the harness.

Simulations were performed for a 14-wire and a 24-wire cable harness bundle. Simulations were performed on a PC using a 3.2 GHz Pentium 4 CPU and with 2 GB memory. For the 14-wire bundle, 200 simulations took approximately 1640 seconds using HSPICE and approximately 6.05 seconds using the T-parameter method, more than 270 times faster. For the 24-wire bundle, 200 simulations using HSPICE took approximately 4293 seconds and approximately 13.78 seconds using the T-parameter method, more than 300 times faster. When using these results to estimate statistical characteristics of cable-harness bundles, additional speedups are expected since the resulting data is already in a MATLAB-compatible format.

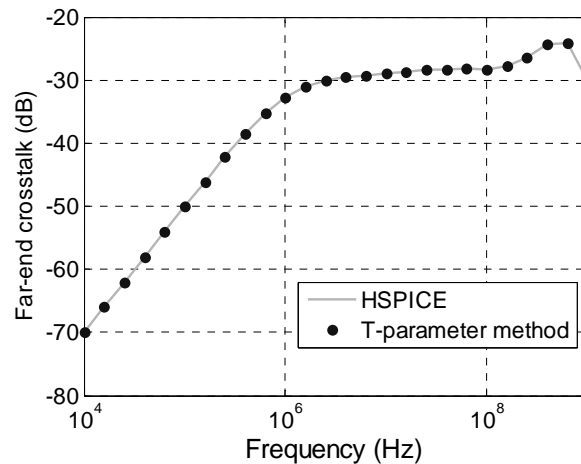

Figure 2.6. Comparison of the simulation results for far-end crosstalk from circuit 2 to circuit 1 for a 14-wire bundle when all wires are loaded with 50 ohm at both ends

The above calculations were performed when wire position changes abruptly from one segment to another. Similar results are expected when position changes smoothly among the segments, though additional time is expected to calculate wire positions before simulation.

## **2.6 DISCUSSION AND CONCLUSIONS**

The T-parameter method can quickly estimate statistical variation of crosstalk in cable-harness bundles without sacrificing accuracy of the calculation. The cable bundle is approximated as cascaded segments of multi-conductor transmission lines. All impedances and values of crosstalk are found using simple matrix calculations once a reference S-parameter matrix has been calculated for a reference harness segment. The accuracy of the T-parameter method was verified by comparing it with the conventional SPICE method. Both methods gave the same result, but the T-parameter method was approximately 300 times faster than the SPICE technique. This added speed is particularly useful for estimating statistical variation of crosstalk where hundreds or even thousands of simulations are required for an accurate result. The added speed is particularly useful as the number of random parameters grows – for example to also model the random variation in harness height, as the number of required simulations generally grows exponentially with the number of random parameters.

## REFERENCES

- [1] D. G. Beetner, H. Weng, M. Wu, T. Hubing, "Validation of worst-case and statistical models for an automotive EMC expert system," *2007 IEEE International Symposium on Electromagnetic Compatibility*, pp. 1-5, July 2007.
- [2] M. Wu, D. Beetner, T. Hubing, "Estimation of the statistical variation of crosstalk in wiring harnesses," *IEEE Int. Symp. on EMC*, August 2008.
- [3] S. Sun, G. Liu, J. Drewniak, and D. Pommerenke, "Hand-Assembled Cable Bundle Modeling for Crosstalk and Common-Mode Radiation Prediction," *IEEE Transactions on Electromagnetic Compatibility*, vol. 49, no. 3, pp. 708-18, Aug. 2007.
- [4] A. Ciccolella and F.G. Canavero, "Stochastic prediction of wire coupling interference," *Proceedings of the 1995 IEEE International Symposium on EMC*, pp. 51-56, 1995.
- [5] J. Fan, A. R. Alexander, J. L. Knighten, and N. W. Smith, "Characterizing multi-port cascaded networks," U.S. Patent 6 785 625 B1, Aug. 31, 2004.
- [6] S. Salio, F. Canavero, J. Lefebvre, and W. Tabbara, "Statistical description of signal propagation on random bundles of wires," presented at the 13<sup>th</sup> Int. Zurich Symp. Electromagn. Compat, Zurich, Switzerland, 1999.

## VITA

Meilin Wu was born on January 5, 1982, in the city of Beihai, Guangxi Province, P.R. China. In 2004, he received his bachelor degree in Engineering Physics from Tsinghua University, Beijing, China. He then continued his studies and received a Master degree of Nuclear Science and Technology in 2006. He joined the Master degree program in Electrical Engineering at the Missouri University of Science and Technology (Missouri S&T) in fall, 2006. While pursuing his Master degree at Missouri S&T, he was supported with a full scholarship as a graduate research assistant in the UMR/MST Electromagnetic Compatibility Laboratory.

