

2016

# Developing and characterization of catfish skin hydrolysates including antioxidant and antimicrobial properties

Cesar Augusto Galindo Perez

*Louisiana State University and Agricultural and Mechanical College*, [cgalindo.yh@gmail.com](mailto:cgalindo.yh@gmail.com)

Follow this and additional works at: [https://digitalcommons.lsu.edu/gradschool\\_theses](https://digitalcommons.lsu.edu/gradschool_theses)



Part of the [Life Sciences Commons](#)

---

## Recommended Citation

Galindo Perez, Cesar Augusto, "Developing and characterization of catfish skin hydrolysates including antioxidant and antimicrobial properties" (2016). *LSU Master's Theses*. 4529.

[https://digitalcommons.lsu.edu/gradschool\\_theses/4529](https://digitalcommons.lsu.edu/gradschool_theses/4529)

This Thesis is brought to you for free and open access by the Graduate School at LSU Digital Commons. It has been accepted for inclusion in LSU Master's Theses by an authorized graduate school editor of LSU Digital Commons. For more information, please contact [gradetd@lsu.edu](mailto:gradetd@lsu.edu).

DEVELOPING AND CHARACTERIZATION OF CATFISH SKIN HYDROLYSATES  
INCLUDING ANTIOXIDANT AND ANTIMICROBIAL PROPERTIES

A Thesis

Submitted to the Graduate Faculty of the  
Louisiana State University and  
Agricultural and Mechanical College  
in partial fulfillment of the  
requirements for the degree of  
Master of Science

In

The School of Nutrition and Food Sciences

By

Cesar Augusto Galindo Perez  
B.S., Zamorano University, Honduras, 2008  
December 2016

## **ACKNOWLEDGEMENTS**

I want to thank God, because he put me at the correct place and time for showing me that without Him, I'm able to do nothing. Thanks to my major advisor, Dr. Subramaniam Sathivel, for all his guidance, support, friendship, advice, economic support, and patience. He was one of the key factors for bringing me to an upper professional level. I want to extend my thanks to my committee members: Dr. Peter Bechtel, Dr. Joan King, and Dr. David Bankston for all their help, advice, and positive feedback for my professional improvement. Thanks to the USDA-ARS for providing the necessary funding for the development of this project. Special thanks to the scientists from the USDA-ARS: Dr. John Bland, Dr. Casey Grimm, and Mr. Steven Lloyd for all their time, scientific knowledge, and effort put in for the peptides' analysis of my samples. Without their help it would not have been possible. Thanks to Dr. Marlene Janes, Ms. Katheryn Parraga, Ms. Marta Escoto, and Mr. Jose Brandao for all their help and guidance for the antimicrobial analysis. Thanks to Ms. Tamara Chouljenko for her friendship, support, and help with the SDS-PAGE analysis, and for keeping H. D. Wilson Laboratories in order and excellent conditions. To my lab-mates: Dr. Kevin Mis, Dr. Arranee Chotiko, Vondel Reyes, Luis Alfaro, Emmanuel Kyereh, Alex Chouljenko, Ronson Scott, Chen Liu, Bennett Dzandu, Vashti Campbell, and Franklin Bonilla for all their friendship, help, and support. Thanks to the Zamorano Agricultural Society (ZAS) for all their support and friendship. Special thanks to my dear wife, Yelby Hernandez, for being my motivation, inspiration, and support all this time. This is an achievement of both. To my family in Guatemala and Nicaragua, thanks for all your support and prayers. And thanks to all those people that work every day at LSU for providing us a safe, clean, and comfortable environment to develop our activities.

## TABLE OF CONTENTS

ACKNOWLEDGEMENTS .....	ii
LIST OF TABLES .....	v
LIST OF FIGURES .....	vi
ABSTRACT.....	vii
CHAPTER 1. INTRODUCTION .....	1
CHAPTER 2. LITERATURE REVIEW .....	3
2.1 Catfish production and processing .....	3
2.2 Catfish skin.....	3
2.3 Protein hydrolysis.....	4
2.4 Bioactive peptides .....	6
2.5 Hydrolysates as antioxidants.....	7
2.6 Hydrolysates as Emulsifiers .....	9
2.7 Hydrolysates and their oil holding capacity .....	10
2.8 Hydrolysates as antimicrobials.....	11
CHAPTER 3. MATERIALS AND METHODS. ....	14
3.1 Materials.....	14
3.2 Methods.....	14
3.2.1 Hydrolysates production.....	14
3.2.2 Degree of hydrolysis (DH), color, and pH of fresh CSH .....	15
3.2.3 Proximate composition .....	17
3.2.4 Free Radical Scavenging activity (FRSA).....	18
3.2.5 Emulsion stability (ES).....	19
3.2.6 Micro-structure of the stable phase .....	20
3.2.7 Oil holding capacity (OHC) .....	21
3.2.8 Sodium dodecyl sulfate polyacrylamide gel electrophoresis (SDS-PAGE).....	21
3.2.9 Disk inhibition antimicrobial assay .....	22
3.2.10 Peptide mass profile of CSH .....	24
3.2.11 Peptide sequence and charge .....	25
3.2.12 Statistical analysis.....	26
CHAPTER 4. RESULTS AND DISCUSSION.....	26

4.1 DH, pH, and Color of CSH .....	26
4.2 Proximate analysis and color of Freeze-dried CSH .....	28
4.3 Free-Radical Scavenging Activity (FRSA).....	31
4.4 Emulsion stability (ES) and oil holding capacity (OHC).....	34
4.5 Micro-structure of the emulsion’s stable phase.....	36
4.6 SDS-PAGE.....	38
4.7 Agar-disk diffusion .....	39
4.8 Peptides production during hydrolysis .....	43
4.9 Peptide molecular weight (MW) distribution, charge profile, and partial sequencing .....	44
CHAPTER 5. SUMMARY CONCLUSIONS.....	45
CHAPTER 6. REFERENCES .....	47
VITA.....	59

## LIST OF TABLES

Table 1. Degree of hydrolysis (DH), pH, and color of fresh CSH as a function of time of hydrolysis with alkaline protease. ....	26
Table 2. Proximate composition of freeze-dried catfish skin and proximate composition and color of freeze-dried CSH as a function of hydrolysis time. ....	30
Table 3. FRSA (mM Teq/L) of different concentrations of CSH as a function of hydrolysis time (ToH). ....	32
Table 4. Emulsion stability (ES) and oil holding capacity (OHC) of catfish skin hydrolysates influenced by the degree of hydrolysis. ....	34
Table 5. Antimicrobial effect of sterilized and non-sterilized CSH obtained at different time of hydrolysis over gram positive and gram negative bacteria. ....	39
Table 6. Molecular weight (MW) distribution of peptides detected in CSH <sub>5</sub> . ....	44
Table 7. Peptides as a function of their net charge in CSH <sub>5</sub> . ....	45

## LIST OF FIGURES

Fig. 1. Schematic representation of chemical and physical mechanisms of antioxidant peptides to inhibit oxidative process. (1) Metal chelation; (2) radical scavenging; (3) physical hindrance (shielding; repulsion). Source: (Nikoo and Benjakul 2015). .....	7
Fig. 2. Mechanism of antimicrobial peptides against gram positive and gram negative bacteria Source: (Wang and others 2015). .....	12
Fig. 3. Disk inhibition assay for testing the antimicrobial capacity of CSH. ....	24
Fig. 4. Micro-structure of the stable phase of the emulsions with highest (a) and lowest (b) emulsion stability obtained when using CSH 6 and CSH 0.5 as emulsifiers respectively. Control emulsion using Tween ® 20 with no CSH addition (c). ....	37
Fig. 5. SDS-PAGE profile of catfish skin hydrolysates and SDS marker. Where column 1= SDS marker; column 2 to 8= CSH after 0.5, 1, 2, 3, 4, 5, and 6 h enzymatic hydrolysis respectively. ....	38
Fig. 6. Disk inhibition assay of filtered-non-sterilized CSH solutions (250 mg/mL) at 4, 5, and 6 h of hydrolysis as antimicrobials against Gram positive <sup>1</sup> and Gram negative <sup>2</sup> bacteria. ....	41
Fig. 7. Disk inhibition assay of filtered-sterilized CSH solutions (250 mg/mL) at 4, 5, and 6 h of hydrolysis as antimicrobials against Gram positive <sup>1</sup> and Gram negative <sup>2</sup> bacteria. ....	42
Fig. 8. Peak area profile of the 10 peptides with largest area generated during CS hydrolysis. Numbers in the bars represent the peak area for each peptide. The top gray bar represents the second set of 10 peptides and the underlined number is the total peptide peak area for the top 20 peptides. ....	43

## **ABSTRACT**

Catfish skin (CS) contains considerable amount of protein that may be hydrolyzed enzymatically to generate hydrolysates (CSH) which may have antioxidant and antimicrobial properties. The generation of natural compounds with these properties is of special interest to the food industry. The objective of this study was to develop and characterize CSH including antioxidant and antimicrobial properties. CSH were produced from different enzymatic reaction periods using alkaline protease, and their characterization, antioxidant, antimicrobial, and some functional properties were evaluated. A selected CSH was analyzed for peptide composition and partial amino acid sequences. The color analysis showed that darker, more yellow, and redder CSH were generated throughout the time of hydrolysis. CSH at 4, 5, and 6 h of hydrolysis showed considerable antioxidant activity and antimicrobial properties in-vitro, high emulsion stability, and low oil holding capacity influenced by the time of hydrolysis. Low-molecular weight peptides with positive charges were suggested as responsible for the antimicrobial activity. CSH were developed and characterized. Further research is suggested, especially on identification, isolation, and synthesis of specific peptides from CSH with both antioxidant and antimicrobial activity.



## **CHAPTER 1. INTRODUCTION**

Catfish is one of the most consumed fish in the United States. According to Hanson and Sites (2015) the average catfish per capita consumption during the period 2000-2013 in the U.S. was 0.41 kg. At the end of that period, catfish was the 8<sup>th</sup> most consumed seafood in the country. The National Marine Fisheries Services (NMFS) reports that in 2013, estimated freshwater U.S. aquaculture production was 653 million pounds valued at \$1.38 billion with catfish leading the list with 358 million pounds (NMFS 2014). Two years later, 138,000 metric tons (MT) were processed in U.S. facilities according to the National Agricultural Statistics Service (NASS 2016). The processing of catfish generates considerable amount of by-products from which skin usually represents 6 % of fish's alive weight (Yin and others 2010) meaning that approximately 8,300 MT of skin were generated as a by-product. Catfish skin protein content and quality are similar to edible fish meat (Himaya and Kim 2014) which suggests that products made from them may be suitable for consumption by humans and thus constitutes an opportunity for producing valuable products through catfish skin processing.

Protein hydrolysates are mixture of peptides of different sizes produced by protein denaturation by the action of acids, alkalis, fermentation, or enzymes (Sarmadi and Ismail 2010; Chalamaiah and others 2012). On a lab scale, enzymatic hydrolysis has been widely reported as capable of producing protein hydrolysates with functional properties (ex. antioxidant, emulsifying, antimicrobial) from underutilized fish species (Amarowicz and Shahidi 1997; Klompong and others 2007; Thiansilakul and others 2007; You and others 2009; Jemil and others 2014) and fish by-products (Benjakul and Morrissey 1997; Šližytė and others 2005; Sathivel and others 2008; Yin and others 2010; Ketnawa and others 2016). The findings reported by these authors suggest

that protein hydrolysates may have the potential of being used as natural food preservatives which could meet current demand in the food market for “all natural” and “clean label” products. Food quality degradation may come from enzymatic autolysis, oxidation, and microbial growth (Ghaly and others 2010). The short shelf life of fresh foods, in addition to the consumer demand for reduction or complete elimination of chemically synthesized preservatives from foods, have reactivated the interest for developing natural shelf life extensors (Roller 1995). Catfish skin hydrolysates may contain peptides with considerable antioxidant and antimicrobial properties; however, there is a lack of information about the catfish skin hydrolysates produced by the alkaline protease and the antioxidant and antimicrobial properties of these hydrolysates in in-vitro conditions.

The objective of this study was to develop and characterize CSH including antioxidant and antimicrobial properties.

## **CHAPTER 2. LITERATURE REVIEW**

### **2.1 Catfish production and processing**

Channel catfish (*Ictalurus punctatus*) is a fresh-water fish whose production and processing started in Alabama around 1950s, and 40 years later, the production reached more than 200 metric tons only from Mississippi, Alabama, Arkansas, and Louisiana (Smitherman and Dunham 1993). Now, there are more than 69,910 acres of water intended for catfish production, and the states with the highest number of acres are Alabama, Arkansas, and Mississippi (Hanson and Sites 2015).

The National Agricultural Statistics Service (NASS) indicates that 2015 live catfish's sales were \$361 million in the US with Mississippi, Alabama, Arkansas, and Texas accounting for 96 % of the sales (NASS 2016). The US demand of catfish is covered by both imported and local raised catfish, and from the latter 36% is commercialized as fresh, and 64% as frozen (NASS 2013). Catfish processing is intended to produce whole dressed fish (19%), fillet (60%), and steaks, nuggets and value added products (21 %) (Silva and Dean 2001). Whole dressed yield (fish weight without head, viscera, and skin) is generally 60 % (Clement and Lovell 1994) This value could change depending on fish age, sex, and genetics. Female fish tend to give both higher whole dressed and fillet yields (58.4 and 43.6 % respectively) than male fish (57.9 and 43.0 %), and hybrids can reach more than 60% and 45% for whole dressed and fillet yield respectively (Argue and others 2003). However, even at the highest yields, processing generates a considerable amount of by-products such as heads, frames, viscera, and skin.

### **2.2 Catfish skin**

Fish skin contains collagen, a protein formed by a triple helix structure linked by hydrogen and covalent bonds which may break if exposed to hot water (Himaya and Kim 2014). Every third residue in the three parallel polypeptide strands is most of the time glycine (Gly) resulting in a

repeating XYGly amino acid sequence, where X and Y can be any amino acid (Shoulders and Raines 2009).

Collagen properties are associated with gelling and surface behavior (Gómez-Guillén and others 2011); however, research has shown more alternative uses. Collagen and gelatin have been extracted from fish skin using alkali and acid methods generating considerable yields (Yang and others 2008; Jamilah and others 2011). Edible films have been produced with extracted gelatin (Zhang and others 2007) and by proteolysis producing protein hydrolysates with considerable activity as emulsifiers and antioxidants (Yin and others 2010; Ketnawa and others 2016), and able to reduce the negative effects of UVA-irradiation on 3-D human skin model (Kato and others 2011). Due to the importance of these properties, the soluble and insoluble fractions of hydrolyzed catfish skin have been studied and described by Yin and others (2010). The results from these authors suggest that protein in catfish skin could be used as substrate for production of hydrolysates with functional properties of interest in the food industry.

### **2.3 Protein hydrolysis**

Protein hydrolysis has been widely applied for fish by-products' processing. It involves the use of acids, alkalis, or enzymes for breaking down parent proteins into protein fractions, peptides, and free amino acids (Kristinsson and Rasco 2000b). The use of acids and alkalis may entail important disadvantages. Acid hydrolysis utilizes strong acids (ex. hydrochloric, sulfuric) that destroy tryptophan; moreover, after hydrolysis, sodium hydroxide is used for neutralizing the solution. This addition of acid and base makes the hydrolysates unpalatable. On the other hand, alkaline protein hydrolysis tends to produce D-amino acids making them indigestible for humans (Anwar and Saleemuddin 1998); furthermore, this type of hydrolysis may generate toxic compounds (ex. lysinoalanine) which are undesirable for human consumption (Himaya and Kim

2014; Kristinsson and Rasco 2000b). Therefore, enzymatic protein hydrolysis seems to be a good alternative for catfish skin protein hydrolysis.

Proteolytic enzymes can cleave peptides bonds acting in two different ways which allows their classification in two groups: exopeptidases and endopeptidases (Damodaran and others 2007). Exopeptidases require amino or carboxyl termini to cleave peptide bonds removing one, two, or three amino acid residues at a time from the N terminus, or one or two at a time from the C terminus. In contrast, endopeptidases do not accept substrates with charged amino or carboxyl termini cleaving peptide bonds deeper in the protein structure generating peptides of different sizes (McDonald 1985; Panyam and Kilara 1996). Bringing out peptides from the native protein structure allows them to exhibit their functionality as bioactive molecules (Di Bernardini and others 2011; Korhonen and Pihlanto 2006) which makes selection of the enzyme a key step of the process.

Alkalines are a sub-group of endopeptidases that have been widely used for producing fish skin protein hydrolysates, and their utilization has also allowed high protein recovery hydrolysates with low lipid content, high nutritional value, and considerable functional properties (Kristinsson and Rasco 2000b). It has been used for the production of giant catfish skin hydrolysates (Ketnawa and others 2016), channel catfish skin hydrolysates (Yin and others 2010), and Pollock skin hydrolysates (Sathivel and others 2008) proving to be a suitable enzyme for hydrolysates production. Furthermore, this group of enzymes has proven to produce hydrolysates with better antioxidant activity at low degrees of hydrolysis compared to other enzymes (Klompong and others 2007).

Degree of hydrolysis (DH) is defined as the percentage of cleaved peptide bonds, and calculated by dividing number of hydrolyzed bonds by the total bonds times one hundred (Nielsen and

others 2001). It is known that DH starts with a high rate that decreases rapidly over time and is influenced by inhibition by hydrolysis products which could explain the curve shape (Valencia and others 2014). This typical shape seems to play an important role in the development of functional properties of protein hydrolysates. Enzymatic hydrolysis of proteins produces three main effects: reduction of molecular weight (MW), increase in number of ionizable groups, and the exposure of hydrophobic groups originally found at the interior of the native proteins structure (Panyam and Kilara 1996). It has been reported that the higher the degree of hydrolysis, the lower the MW of protein/peptides produced (Severin and Xia 2006). Change in MW affect hydrolysates functional properties showing that high MW peptides (low DH) have better emulsion capacity, emulsion stability, and fat absorption, and hydrolysates produced with further hydrolysis (high DH) tend to have better solubility in water (Gbogouri and others 2004; Sathivel and others 2008; Severin and Xia 2006; Klompong and others 2007). Hydrolysates with low molecular size tend to diffuse and absorb rapidly to the interface in emulsions, but they cannot unfold and reorient at that point like large peptides limiting the emulsion capacity and stability (Gbogouri and others 2004).

## **2.4 Bioactive peptides**

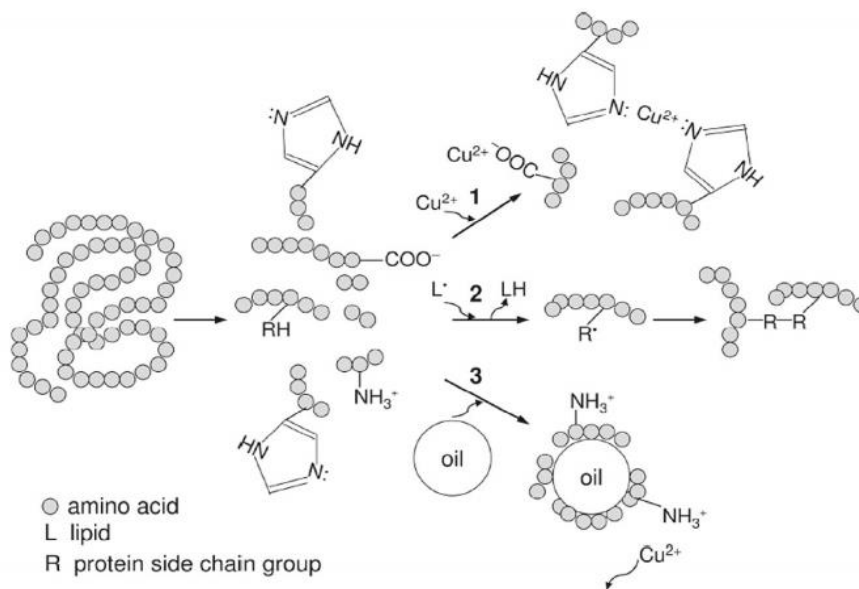
Bioactive compounds are defined by Biesalski and others (2009) as “*essential and non-essential compounds (e.g., vitamins or polyphenols) that occur in nature, are part of the food chain, and can be shown to have an effect on human health*”, and as mentioned in advance, some peptides have shown potential as bioactive compounds especially the ones with low-molecular weight. In fact, molecular weight is one of the most important factors determining peptides’ physicochemical and biological activities (Najafian and Babji 2012; Sarmadi and Ismail 2010). Hydrolysates with large portions (>50%) of peptides under 3 kDa have been previously linked to antimicrobial activity, and short peptides with MW less than 3 kDa were linked to high

angiotensin-converting enzyme (ACE) inhibitory effect (Jang and others 2008; Jang and Lee 2005) and strong antioxidant activity (Ngo and others 2010; Je and others 2007; Je and others 2005; Rajapakse and others 2005; Wu and others 2003).

## 2.5 Hydrolysates as antioxidants

Antioxidant properties have been related to fish protein hydrolysates (Di Bernardini and others 2011; Valencia and others 2014). These properties are related to the interaction between the functional groups of amino acids conforming the peptide sequence ( $-\text{NH}_2$ ,  $-\text{SH}$ ,  $-\text{OH}$ , and  $-\text{COOH}$ ) with hydroperoxides or pro-oxidants during lipid oxidation (Zayas 1997) reducing the oxidation reaction rate, especially during the propagation stage.

Peptides can act as antioxidants by three mechanisms: metal chelation, radical scavenging, and physical hindrance (Nikoo and Benjakul 2015). These mechanisms are represented in Figure 1.



**Fig. 1.** Schematic representation of chemical and physical mechanisms of antioxidant peptides to inhibit oxidative process. (1) Metal chelation; (2) radical scavenging; (3) physical hindrance (shielding; repulsion). Source: (Nikoo and Benjakul 2015).

Metal chelation and radical scavenging are both chemical mechanisms that involves the donation of an electron from the peptide to a metal or to a radical respectively (Huang and others 2005). On the other hand, the physical hindrance occurs by physical repulsion between positive amino acids' functional groups and positively charged metals. Lipid oxidation may be retarded by neutralizing the radicals that cause oxidation itself or by chelating metal ions that accelerate lipid oxidation (Damodaran and others 2007).

Hydrolysates with considerable antioxidant activity have been obtained from different protein sources. These sources include hearing by-products (Sathivel and others 2003), pollock skin (Sathivel and others 2008) and frame (Je and others 2005), giant catfish skin (Ketnawa and others 2016), loach (You and others 2009), yellow stripe trevally (Klompong and others 2007) and fresh water carp (Elavarasan and others 2014). Factors such as DH, the type of enzyme, and the peptide amino acid composition influence protein hydrolysates' antioxidant capacity. Results reported by Klompong and others (2007) suggest an increase in the antioxidant capacity while DH increases until a certain point; however, further hydrolyzation tends to produce large quantity of short peptides and free amino acids that reduce antioxidant activity (Wu and others 2003; You and others 2009). Higher antioxidant activity at the same DH (5%) has been reported for yellow stripe trevally hydrolysates that were hydrolyzed using Alcalase compare to hydrolysates produced with Flavourzy. Nevertheless, the opposite enzyme effect was observed on round scad hydrolysates at higher DH (20,40, and 60%) (Thiansilakul and others 2007) suggesting that not only the type of enzyme affects antioxidant capacity, but also the substrate used as the source of protein for hydrolysis.

Amino acid composition has been linked to the antioxidant capacity of hydrolysates too. Tyrosine, glycine, aspartic acid, and glutamate have been reported as radical scavengers due to



the capacity to serve as hydrogen donors (Di Bernardini and others 2011; Qian and others 2008). Non-polar (alanine, valine, leucine, and proline) amino acids have high reactivity with hydrophobic polyunsaturated fatty acids, and aromatic amino acids (tyrosine, histidine, tryptophan, and phenylalanine) can stabilize reactive oxygen species (ROS) through direct electron transfer (Qian and others 2008). The concentration of tyrosine, methionine, histidine, lysine, and tryptophan residues on hydrolysates also has generated a positive antioxidant effect which could be due to the chelating and lipid radical scavenging ability of imidazole ring on histidine (Chen and others 1996) and proton donation to radicals by the aromatic amino acids (You and others 2009). Glycine, histidine, and tryptophan have shown potential antioxidant activity at pH between 6 to 7 in linoleic acid emulsions with phosphate addition (0.1 mol) (Marcuse 1962). Free radical scavengers could inhibit lipid oxidation by reacting faster with free radicals than unsaturated fatty acids do (Damodaran and others 2007).

## **2.6 Hydrolysates as Emulsifiers**

Emulsions are systems involving two liquids that are by nature immiscible, one dispersed (dispersed phase) into the other (continuous phase) generating oil in water (O/W) or water in oil (W/O) emulsions. This system involves oil, water, an emulsifier, and energy where the oil or water will form continuous or dispersed phase, the energy will deform and break up droplets usually bigger than 2  $\mu\text{m}$ , and the emulsifier will prevent coalescence of the dispersed droplets (Damodaran and others 2007). According to Amarowicz (2010) evaluation of food protein emulsifying properties may include any of the following parameters: emulsion activity (maximum interfacial area per unit mass of protein in a stabilized solution), emulsion capacity (maximum amount of oil emulsified under specified conditions by unit of mass of protein), and

emulsion stability (capacity of a protein to form an emulsion that remains unchanged for a certain time period at given temperature and gravitational field).

Protein hydrolysates' emulsifying properties are influenced by different factors. Hydrolysates' amphiphilic nature and water solubility promote the formation of O/W emulsions (Kristinsson and Rasco 2000b). It is also known that higher protein effective hydrophobicity generates a stronger affinity to the non-polar phase, causes a greater decrease in interfacial tensions, and produces a better emulsifying activity (Kato and Nakai 1980). Furthermore, unfolded structures improves emulsifying properties increasing the protein/hydrolysate capacity to form a protective layer around fat globules in the emulsion system stabilizing it (Zayas 1997).

The degree of hydrolysis plays an important role in emulsifying properties. Proteins with low DH have shown better EC and ES than those with larger DH (Šližytė and others 2005). Turgeon and others (1991) suggested that for hydrolysates EC tends to decrease while DH increases due to the fact that too small peptides cannot unfold and spread like proteins or higher MW polypeptides at the interface reducing their efficiency in decreasing surface tension. In fact, surface-active compounds need to adsorb rapidly to the interface, unfold, orientate its hydrophobic groups toward the dispersed phase and its polar groups toward the continuous phase for reducing free energy, and form strong and elastic films by the interaction with neighboring molecules (Kato and Nakai 1980; Zayas 1997; Damodaran and others 2007).

## **2.7 Hydrolysates and their oil holding capacity**

Knowing that fat is able to improve the quality of foods through texture, appearance, and flavor enhancement (Damodaran and others 2007), the retention of it into the food product structure requires special attention. For that reason, fat/oil holding capacity (OHC) of protein hydrolysates may be of interest for the food industry. This ability of proteins to hold fat has been linked

mainly to oil's physical entrapment where protein-lipid interactions include electrostatic, hydrophobic, non-covalent and hydrogen bonds (Zayas 1997).

Different factors may affect the OHC. Low dispersibility, controlled denaturation, and high hydrophobicity seems to favor OHC in proteins (Li-Chan and others 1985). Protein degradation to oligopeptides by enzymes during fermentation also has improved this property (Yu and others 2007).

The capacity of protein hydrolysates for holding fat has been reported by other authors. Sardinelle, zebra blenny, globy, and ray protein hydrolysates OHC were reported by Jemil and others (2014). Li-Chan and others (1985) reported OHC for beef top round and rockfish fillet hydrolysates. Fat absorption values of herring by-products and capelin hydrolysates were reported by Sathivel and others (2003) and Shahidi and others (1995) respectively. However, there is limited available information about catfish skin hydrolysates oil holding capacity in the literature.

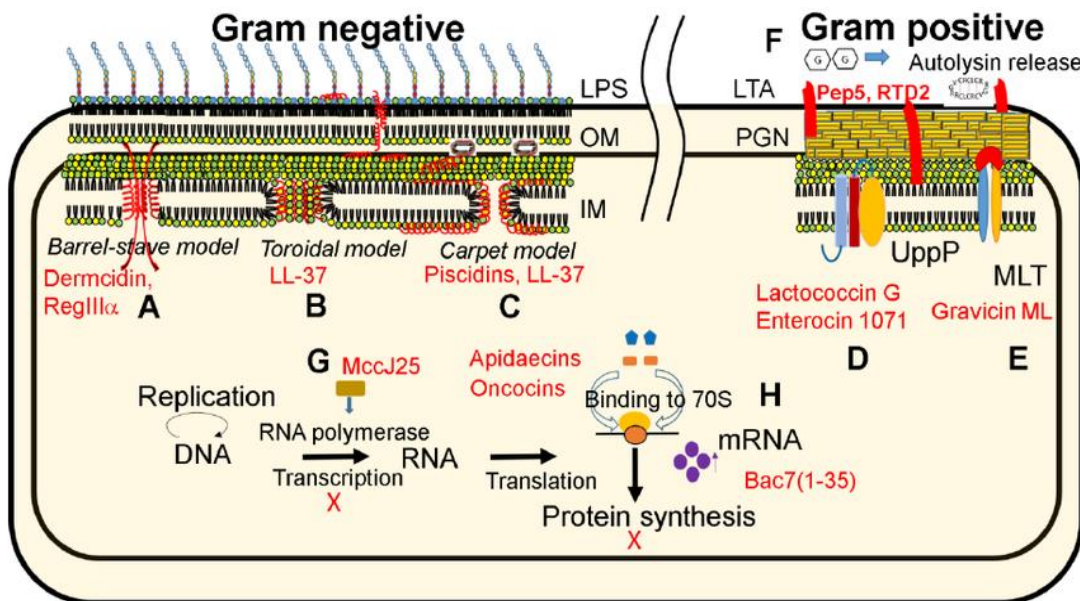
## **2.8 Hydrolysates as antimicrobials**

Antimicrobial activity of peptides from meat and byproducts' hydrolysates (Di Bernardini and others 2011) and fish sources (Najafian and Babji 2012) has been attributed to positively charged peptides able to form an amphipathic secondary structure in a membrane environment (Dathe and others 1997). These peptides bind to negatively charged molecules and substances in the cell membrane of pathogens (Yeaman and Yount 2003).

The mode of action of antimicrobial peptide varies depending of the host nature. In gram negative bacteria, the antimicrobial activity of peptides goes through three stages: binding of the peptide to the bacteria's surface, insertion, and destabilization of the cell membrane (Dathe and others 2001). The binding stage seems to be due to electrostatic attractions (Yeaman and Yount 2003), and the penetration and the destabilization of the cell membrane seems to be caused by

the interaction of the hydrophobic helix surface of the peptide with the phospholipid layer in the cell membrane (Dathe and others 2001).

Different mechanisms have been proposed for explaining the mode of action of the antimicrobial peptides. Brogden (2005) explains 3 models. The barrel-stave model (Fig. 2 A) suggests that peptides orient perpendicularly to the cell membrane and insert into the bilayer phospholipid membrane by the interaction between the hydrophobic areas of the peptides with the lipid region of the cell membrane.



**Fig. 2.** Mechanism of antimicrobial peptides against gram positive and gram negative bacteria  
Source: (Wang and others 2015).

The toroidal-pore model (Fig. 2 B) suggests the bending of the phospholipid's polar region toward the peptides' polar region perpendicularly aligned to the cell membrane surface. The carpet model (Fig. 2 C) suggests the parallel aggregation of peptides over the cell lipid bilayer through the interaction of hydrophilic regions of both peptides and phospholipid by electrostatic forces. In these 3 models, the peptides generate pores in the cell membrane and the bacteria will die due to cell lysis. On the other hand, the gram positive bacteria are affected on different ways.

The peptides bind to the cell surface by electrostatic interactions and affect the bacteria by altering enzymes responsible for the cell membrane synthesis (Fig. 2 D), maltose ABC receptors (Fig. 2 E), or causing an over-production of autolysin (Fig. 2 F) which deteriorates the cell membrane. In addition, antimicrobial peptides can alter the DNA transcription (Fig. 2 G) or the protein production (Fig. 2 H) in both gram positive and gram negative microorganisms causing the cell death (Wang and others 2015).

Specificity of antimicrobial peptides toward pathogenic bacteria instead of human cells has been related (in part) to cell membrane composition. Most pathogenic bacteria have highly electronegative phospholipids (phosphatidylglycerol, cardiolipin, and phosphatidylserine) on the cell membrane compared to mammalian cytoplasmic membranes that usually have more neutral net charge phospholipids (phosphatidylcholine, phosphatidylethanolamine, and sphingomyelin) (Yeaman and Yount 2003). This characteristic may promote higher electrostatic attraction between bacteria's cell membrane and cationic peptides.

The role of electrostatic attraction in the antimicrobial effect of peptides makes it logical to hypothesize that the number of peptides' net positive charges may influence the attraction. In fact, most of the antimicrobial peptides reported on the literature have a net charge between +2 to +9 (Yeaman and Yount 2003). Findings reported by Dathe and others (2001) suggest that increasing the positive net charges of cationic peptides (from +3 to +5) can make some peptides more active and selective against pathogenic bacteria rather than human cells as antimicrobials; however, the addition of more positive charges may cause the opposite effect probably due to the fixation of the peptide to the lipid head group of phospholipids inhibiting insertion and disturbance of the cell membrane (Yeaman and Yount 2003). These findings suggest that identification of peptide charges is highly important.

## **CHAPTER 3. MATERIALS AND METHODS.**

### **3.1 Materials**

Fresh catfish skin (CS) was obtained from a local seafood plant in Baton Rouge, LA, and transported to the pilot plant of the School of Nutrition and Food Sciences at LSU in an ice chest with ice. The CS was immediately vacuum packaged (Koch UV-550, Kansas City, MO, USA), frozen in an air-blast freezer at -20 °C, and kept at that temperature until used (no more than 2 weeks). Food grade enzyme alkaline protease 380 MG (380,000 DAPU/g) was obtained from Enzyme Development Corporation (New York, NY). Unless otherwise specified, buffers, stains, and equipment used for SDS-PAGE analysis were Bio-Rad products (Bio-Rad Laboratories, Hercules, CA, USA). The media for bacteria growth was obtained from Neogen ® Corporation (Lansing, MI, USA). Gram positive and gram negative bacteria were obtained from the LSU AgCenter Food Safety and Microbiology lab (Baton Rouge, LA). Unless otherwise specified, all other chemicals used for analysis were obtained from Sigma-Aldrich ® (St. Louis, MO, USA).

### **3.2 Methods**

#### **3.2.1 Hydrolysates production**

Catfish skin hydrolysates were prepared according to the method described by Sathivel and others (2003) with modification of the centrifuge *g* force. CS was thawed overnight at 5 °C, cleaned, and ground using a Koch grinder (C/E6B0N, Kansas City, MO, USA) with a plate of 10 mm diameter and holes of 0.3 mm diameter. Seven independent samples were prepared by homogenizing. For each sample, 100 g of ground CS were mixed with 100 mL distilled water using a Waring commercial blender (model 51BL32 700, Waring Laboratory, Torrington, CO) for 2 min. The homogenized sample was poured into an Erlenmeyer flask 500 mL capacity, and the temperature was increased to 60 °C using a hot plate stirrer with constant agitation. At 60 °C, alkaline protease enzyme (380,000 DAPU/g) was added at 0.5 % w/w protein of catfish skin

(0.104 g enzyme/100 g CS). The sample was placed in a shaker at 60 °C with constant agitation at 150 rpm. Each of the seven samples was removed from the shaker at different reaction times (0.5, 1, 2, 3, 4, 5 and 6 h). The enzyme was inactivated by increasing and keeping the sample's temperature at  $86 \pm 0.5$  °C for 20 min in a water bath. The degree of hydrolysis was measured as described below. Then, the sample was centrifuged at  $3110 \times g$  (model J2-HC, Beckman Instruments, Inc., Palo Alto, CA) for 15 min. The supernatant, that in fact constitutes the catfish skin hydrolysate, was removed carefully and filtered through a double layer of cheese cloth. The CSH production was replicated 3 times using 3 independent batches of catfish skin, and after the filtering step the color and the pH of each CSH were measured by using the methods described in the section 3.2.2. For the measurement of other properties, the CSH were frozen at -40 °C using a cabinet-type cryogenic freezer with liquid nitrogen (Air Liquide, Houston, TX, USA) and subsequently freeze-dried in a pilot lyophilizer (Genesis 35XL, VirTis, Gardiner, NY, USA). Dried samples were kept into Whirl-pac® bags in a desiccator until analyzed. The nomenclature “CSH #” was used to describe “catfish skin hydrolysate generated at # h of hydrolysis time.”

### 3.2.2 Degree of hydrolysis (DH), color, and pH of fresh CSH

The DH was evaluated following the method described by Nielsen and others (2001). O-phthaldialdehyde (OPA) reactant solution was prepared by diluting 7.62 g sodium tetraborate decahydrate and 0.20 g of sodium-dodecyl-sulfate in 150 mL of distilled water in a 400 mL flask. Four mL of ethanol (95%) was used to dilute 0.16 g of o-phthaldialdehyde, and it was added to the previous mixture. The OPA-reactant solution was completed by adding 0.176 g dithiothreitol (DTT) and distilled water to make 200 mL of solution. A serine standard solution (0.9516 serine-NH<sub>2</sub> meqv/L) was prepared by diluting 0.05 g of serine in 500 mL distilled water. After enzyme inactivation, an aliquot of 0.1 to 1 g of the sample was diluted by adding distilled

water up to make a total of 100 mL. Three mL of OPA-reactant solution were mixed with 400  $\mu$ L of the diluted sample. After 2 min standing at room temperature, the absorbance (Abs) of the OPA reactant–sample mixture was read using a Thermo Scientific Genesys® 20 spectrophotometer at 340 nm. Four hundred  $\mu$ L of the serine standard solution (standard) were mixed with 3 mL OPA-reactant and analyzed in the same way as the sample. For the blank, 400  $\mu$ L of distilled water were used for reacting with OPA-reactant solution and analyzed as previously described. Equation 1 was used to calculate the serine-NH<sub>2</sub> milliequivalents (meqv) per gram of protein found in the hydrolyzed sample after enzyme inactivation.

$$\text{Serine} - \text{NH}_2 = \left( \frac{\text{Abs sample} - \text{Abs blank}}{\text{Abs standard} - \text{Abs blank}} \right) * 0.9516 \frac{\text{meqv}}{\text{L}} * 0.1 * \frac{100}{X * P} \quad (\text{Eq. 1})$$

Where serine-NH<sub>2</sub>= meqv of serine per gram of protein; 0.1= total volume of the diluted sample in liters; X= g of aliquot (range from 0.1 to 1 g); 0.9516 meqv/L= serine-NH<sub>2</sub> concentration (milliequivalents per liter) in the serine standard solution; P= is the protein content (%) of the sample. Thus, 100/(X\*P) = grams of protein.

The serine-NH<sub>2</sub> meqv/g protein result was used for calculating *h* (equivalent of cleaved peptide bonds) (eq. 2). The values of  $\alpha$  and  $\beta$  in equation 2 come from a linear equation reported by Adler-Nissen (1986) that explains the relationship between *h* and serine-NH<sub>2</sub> during fish protein hydrolysis using alcalase protease. Serine-NH<sub>2</sub> is a predictor of *h*. Constant values of 1.00 and 0.40 for  $\alpha$  and  $\beta$  respectively assist to explain the linear relationship of Serine-NH<sub>2</sub> and *h* during the hydrolysis of fish protein using alcalase protease.

$$h = \frac{\text{Serine} - \text{NH}_2 - \beta}{\alpha} \quad (\text{Eq. 2})$$

The DH (%) was calculated (Eq. 3) by dividing *h* by *htot* times 100. The denominator *htot* is the total peptide bonds equivalents found in the native protein under evaluation. That value is based



on the amino acid composition reported in the literature for the evaluated protein (Adler-Nissen 1986). The *htot* value for fish protein is 8.6.

$$DH (\%) = \frac{h}{htot} * 100 \quad (Eq. 3)$$

The color of fresh and freeze-dried CSH was determined with a colorimeter (LabScan XE, Hunter Associates Laboratory, Inc., Reston, VA, USA). White and black tiles were using to standardize the colorimeter. Four mL (fresh) or 0.1 to 1 g (freeze-dried) of CSH obtained at the different times of hydrolysis were poured into a plastic tray and placed under the colorimeter lens for reading the color. The color was obtained in a Lab scale where L=0 is black, L=100 is white, a= “+” value is redness or “-” value is greenness, and b= “+” value is yellowness or “-” value is blueness.

The pH of the fresh CSH was measured by using a SympHony pH-meter (SB70P, VWR, Radnor, PA, USA) by directly placing the electrode into a CSH solution (200 mg/mL) prepared for each of the hydrolysates obtained after different times of hydrolysis with alkaline protease.

### 3.2.3 Proximate composition

Moisture determination of freeze-dried CSH was done by using a CEM moisture analyzer (Smart System 5, CEM Corporation, Matthews, NC, USA). Protein content was estimated as 5.82 times the nitrogen content (Sosulski and Imafidon 1990) determined by Dumas combustion in a TruSpec nitrogen analyzer (Leco, MI, USA) at the Soil Testing and Plant Analysis Lab., LSU AgCenter. Lipid content was determined by the Soxhlet extraction method AOAC 960.39 (AOAC 1995) using petroleum ether as the solvent. The ash content was determined using a muffle furnace at 500 °C overnight. Carbohydrate content was estimated by difference between total solids and the determinations of fat, protein, and ash.

### 3.2.4 Free Radical Scavenging activity (FRSA)

FRSA was analyzed using the 2,2-diphenyl-1-picrylhydrazyl (DPPH) method described by Elavarasan and others (2014) with some modifications. DPPH is a free radical of purple color whose intensity can be read with a spectrophotometer at 517 nm. When DPPH reacts with an antioxidant, the DPPH is scavenged and the color intensity is reduced. The reaction between DPPH and any antioxidant solution should take place in the dark because the color intensity of DPPH is light sensitive. A DPPH solution was prepared by diluting 0.0039 g of DPPH in 100 mL ethanol (purity 95%) for a final DPPH concentration of 0.1 mM. Trolox stock solution was made by diluting 0.020 g of trolox in 100 mL ethanol (purity 95 %) for a final trolox concentration of 800  $\mu$ M. Subsequently, 1.5 mL of this stock solution was diluted in 18.5 mL ethanol (purity 95%) in order to prepare the working solution at 60  $\mu$ M trolox concentration. A stock solution for each CSH produced at the different hydrolysis times was made by diluting 1.25 g freeze-dried CSH in 5 mL distilled water for a final concentration of 250 mg CSH/mL. Four solutions at different CSH concentrations (50, 100, 150, and 200 mg/mL) were made by diluting the stock solution of each CSH with distilled water. The resultant solutions and the stock solution of each CSH were diluted by a factor of 10. From each of the resultant diluted solutions, 1.5 mL was mixed in a test tube with 1.5 mL of DPPH solution using a vortex at 2200 rpm for 1 min and the resultant mixture's reaction took place in the dark for 30 min at room temperature (22 °C). Absorbance of the mixtures was measured at 517 nm using a Thermo Scientific Genesys® 20 spectrophotometer. The trolox working solution was diluted in concentrations ranging from 0 to 60  $\mu$ M using distilled water. The resultant trolox solutions were mixed with DPPH solution and analyzed following the same procedure as explained for the CSH samples. A standard curve was prepared from the results of absorbance from the reaction between DPPH

solution and the different concentrations of trolox working solution. A linear equation (Eq. 4) was obtained ( $R^2 \geq 0.95$ ) for the absorbance as a function of trolox concentration. This equation was used for calculating the FRSA, expressed as millimol trolox equivalent per liter (mMol Teq/L) from the absorbance obtained after the reaction between DPPH solution and each of the CSH produced at different hydrolysis times (0.5, 1, 2, 3, 4, 5, and 6 h) at the different concentrations (50, 100, 150, 200, and 250 mg CSH/mL). The result was multiplied by 10 to account for the dilution made in advance.

$$Y = -0.0087X + 0.5026 \quad R^2=0.9661 \quad (Eq. 4)$$

Where  $X$ = mMol Teq/L;  $Y$ = absorbance generated after 30 min of reaction between CSH and DPPH in dark; -0.5026 and -0.0087= constants for the slope and intercept of the line.

### 3.2.5 Emulsion stability (ES)

The capacity of CSH to keep an emulsion stable was evaluated according to the method of Kristinsson and Rasco (2000a). A sample of 0.500 g CSH was weighed and placed in a beaker (50 mL capacity). Approximately 35 mL of a 0.1 M NaCl solution was added to the beaker, and the CSH was diluted with constant agitation with a stirrer plate for 2 min. The resulting solution was transferred to a volumetric flask and additional NaCl solution was added until a total volume of 50 mL was obtained. The resulting CSH solution and an equal volume of soybean oil were blended in a commercial blender (model 51BL32 700, Waring Laboratory, Torrington, CO) for 2 min to obtain 100 mL of oil in water (O/W) emulsion. Immediately, three 25 mL aliquots of the resulting O/W emulsion were poured into graduated cylinders (25 mL capacity), and after 15 min of rest at ambient temperature (22 °C) the aqueous volume was read on the cylinder scale (mL). ES was calculated with equation 5.

$$\% \text{ emulsifying stability} = \frac{T_v - A_v}{T_v} \times 100 \quad (Eq. 5)$$

Where  $T_v$  is total volume (mL) of the emulsion initially poured into the graduated cylinder and  $A_v$  is the aqueous volume observed after 15 min of rest. The difference between  $T_v$  and  $A_v$  represent the volume of emulsion that remained stable after 15 min of rest.

### 3.2.6 Micro-structure of the stable phase

Transmission electron microscopy (TEM) was used in an endeavor to look at the interfacial characteristics and micro-structure of the oil contained in the stable phase of the emulsions from the ES analysis. Five mL were taken from an emulsion made following the procedure used for ES analysis using CSH at 0.5 and 6 h of hydrolysis time (the ones that possessed the lowest and highest ES respectively). No colorant was added to the oil. From the resulting sample, 5  $\mu$ L were placed over a glow discharge carbon filmed grid (CF300-Cu, Electron Microscopy Sciences, Hatfield, PA, USA) followed by 2 min of stabilization. Excess sample was removed by carefully placing the carbon grid on a filter paper (Whatman # 1). The grid containing the sample was stained with a solution of 2% aqueous uranyl acetate (Electron Microscopy Sciences, Hatfield, PA, USA) by placing the grid for 1 min over 50  $\mu$ L of the staining solution previously poured on a parafilm wax paper. After that, the carbon grid was removed from the surface of the staining solution, and the excess of staining solution was removed by placing the carbon grid on a filter paper (Whatman # 1). These carbon grids containing the stained sample were placed into a Jeol-USA TEM (JEM-1400, Peabody, MA, USA). Pictures were obtained using a US1000XP 2 camera at 6000x magnification and beam energy of 120 kV. An emulsion of 10 mL soybean oil and 90 mL 0.1 M NaCl was made by adding 1.125% of commercial Tween 20 emulsifier. A TEM picture of this last emulsion was used as a control for microstructure comparison.

### 3.2.7 Oil holding capacity (OHC)

The effect of DH on OHC of CSH was evaluated according to the method of Šližytė and others (2005) with some modifications. Ten mL of soybean oil were added to 0.500 g of freeze-dried CSH in an Eppendorf tube (pre-weighed) at room temperature (22 °C). The mixture was kept at room temperature for 30 min and stirred with a small spatula every 10 min during this period. After that, the samples were centrifuged at 2,450 x g for 25 min while holding the temperature in a range of 20 to 25 °C. After pouring off the supernatant (non-retained oil), the weight of the tube containing the CSH plus the retained oil was measured. The amount of oil retained by 0.5 g CSH was calculated by weight difference between the latter weight and the sum of the weight of the empty tube plus the weight of the CSH sample. Because some oil attached to the Eppendorf tube wall, a correction was determined by measuring the weight of the residual oil after adding and pouring 10 mL of oil in an Eppendorf tube. This factor was subtracted from all the values of retained oil/0.5 g CSH. OHC was calculated by multiplying the value of retained oil/ 0.5 g CSH by 2, and the result was reported as g retained oil/g of CSH. The density of the oil was determined by weighing 6 replicates of 10 mL soybean oil samples.

### 3.2.8 Sodium dodecyl sulfate polyacrylamide gel electrophoresis (SDS-PAGE)

MW profiles of the CSH samples produced at different hydrolysis reaction times were generated through an SDS-PAGE analysis method according to Yin and others (2010) with some modifications. A CSH solution (2 mg CSH/mL) was made using distilled water for each of the CSH samples. From the resulting solutions and for each sample, ten µL were mixed with the same volume of tricine sample buffer and boiled at 95 °C for 5 min in a dry bath (AccuBlock™ digital dry bath, Labnet International, Inc., Edison, NJ). After 1 min of rest at room temperature (22 °C), the samples were centrifuged for 10 s (Eppendorf Centrifuge 5415 D, Hamburg, DK). A

precast polyacrylamide gel (10-20% Mini-protean tris-tricine gel) with wells for loading 10 individual samples was placed in a single sided vertical gel electrophoresis system filled with 10% running buffer solution (10x Tris/Tricine/SDS) until the gel was completely covered. Subsequently, 5  $\mu$ L of a pre-stained protein standard (Precision plus protein <sup>TM</sup> Dual Xtra 2-250 kD) were loaded in the first well of the precast gel, and 10  $\mu$ L of the centrifuged CSH samples (7 in total) were loaded in the subsequent wells (one sample per well) following an ascending order based on the time of hydrolysis used for producing the CSH. PowerPac Basic <sup>TM</sup> equipment was used as a source of energy for the anode (- pole) and cathode (+ pole) in the electrophoresis system. After 100 min of running, the gel was carefully removed and placed in a case with a prepared buffer solution of distilled water, methanol, and acetic acid in a ratio at 5:4:1 for 30 min over a bench rocker (S2025B, Labnet international, Inc., Edison, NJ) at 70 RPM. The fixing buffer was removed and replaced with Coomassie stain (Bio-Safe<sup>TM</sup> Coomassie G-250 Stain). After 2 h, the stain was replaced by distilled water and the gel was washed overnight. GelDoc <sup>TM</sup> EZ Imager was used for taking a gel picture and visualizing sample and standard protein bands using the Image Lab 4.0.1 program.

### 3.2.9 Disk inhibition antimicrobial assay

Based on the antioxidant activity, 3 CSH were selected (the ones generated at 4, 5, and 6 h of hydrolysis) for testing their antimicrobial capacity against Gram positive *Bacillus cereus*, *Staphylococcus aureus*, and *Listeria monocytogenes* and Gram negative *Escherichia coli* O157:H7. The agar-disk diffusion method according to Jang and others (2008) with modifications was used to determine the effectiveness of the CSH. Muller Hilton Broth (MHB, 21 g/L of distilled water), regular agar (21 g MHB and 16 g Agar per liter), and soft agar (21 g BHI and 8 g agar per liter) were made. Each strain of the bacteria mentioned before was isolated

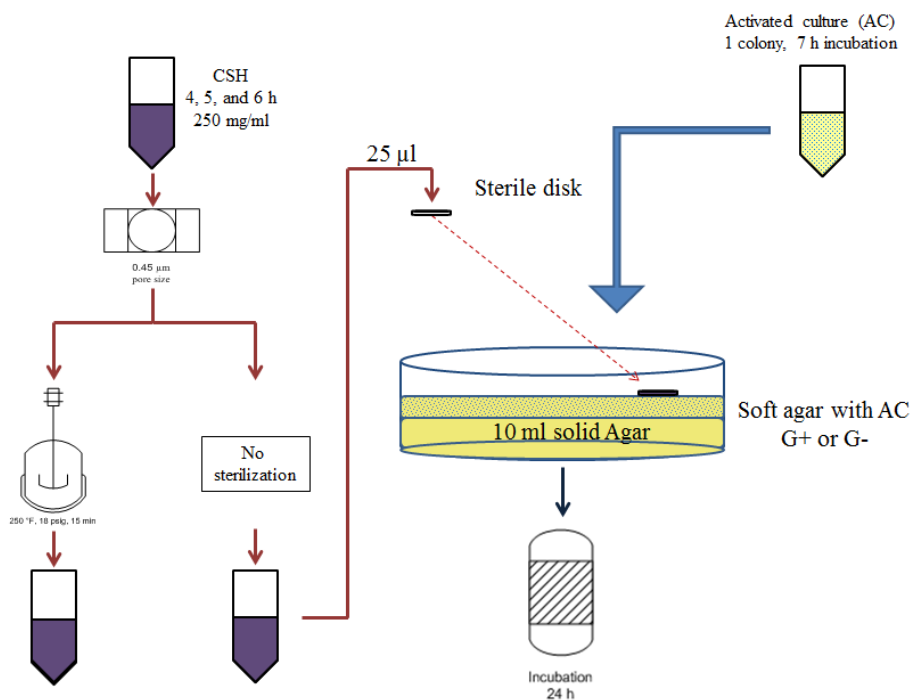
and activated as explained below. A loop of pure bacteria culture was placed into an Eppendorf tube (15 mL capacity) containing 10 mL of sterile MHB. After 10 seconds of mixing with a vortex at 2200 RPM, MHB tubes containing *B. cereus* were incubated for 24 h at 30 °C, and the tubes containing the other bacteria were incubated for 24 h at 37 °C. Two plates with selective media for each bacterium under analysis were inoculated with a loop of incubated MHB using the streak technique. These plates were incubated under the same time and conditions previously described. Isolated colonies were obtained after the incubation period. One isolated colony of each bacterium was placed in an Eppendorf tube containing 10 mL sterile MHB and incubated for 7 h at temperatures previously described. The result was an activated culture (AC) for each bacterium containing about  $10^6$  cells per mL.

After sterilization, approximately 10 mL of agar was poured into petri dishes and allowed to solidify at room temperature. Tubes with 10 mL soft agar were sterilized, inoculated with 100  $\mu$ L of AC, and vortexed for 10 s. The content of each tube was poured into petri dishes with a first layer of agar prepared in advance, and the tube contents were solidified at room temperature.

A solution (5 mL) of each of the 3 selected CSH were made diluting freeze-dried CSH into distilled water for a final concentration of 200 mg/mL. Subsequently, the resulting solution was filtered using 0.45  $\mu$ m syringe filters. One set of filtered solutions from the 3 selected CSH was sterilized by autoclave. A second set was just filtered using the syringe filter mentioned previously.

A blank sterile paper disk (BBL <sup>TM</sup> Becton, Dickinson and Company) 6 mm diameter was saturated with 25  $\mu$ L of a CSH solution (either filtered and autoclaved, or just filtered), and immediately placed on the surface of the solidified soft agar. This was done for each of the CSH solutions for each of the treatments (filtered and autoclaved or just filtered) and for each

bacterium. The Petri dishes were incubated at 30 °C for *B. cereus* and 37 °C for the other bacteria for 24 h. The procedure is summarized in the next figure (Fig 3).



**Fig. 3.** Disk inhibition assay for testing the antimicrobial capacity of CSH.

The result was graded as positive (+) or negative (-) based on the presence or absence of antimicrobial activity respectively. For CSH with antimicrobial activity, an inhibition zone (area with no bacteria growth) was observed around the disk after the incubation period.

### 3.2.10 Peptide mass profile of CSH

Peptide masses in CSH after different hydrolysis times and in a control were identified using High Performance Liquid Chromatography and Mass Spectroscopy (HPLC-MS). The control was CSH produced under the same procedure previously stated except that the enzyme was immediately inactivated after its addition to the catfish skin/distilled water homogenate. Freeze-dried CSH samples were diluted in distilled water (5.7 mg/mL), and 10 µL of the resultant solution were injected using an Alliance 2695 HPLC and LCT Premier XE mass spectrometer (Waters Corp., Milford, MA, USA) onto a Luna C18 (3 µm, 2x50mm) column operated at 30 °C



and 0.3 mL/min flow rate for readout by a photodiode array detector (Waters 996, Waters Corp., Milford, MA, USA). A mobile phase with a gradient of 10-30 % Acetonitrile/0.1% formic acid over 7 min was used to elute the peptides. The mass spectrometer was equipped with an ESI source operated in positive and negative mode scanned from 200-2000 mass/charge (m/z) ratio. Results were analyzed with the program MassLynx V4.1 SCN639 (Waters Corp., Milford, MA, USA).

### 3.2.11 Peptide sequence and charge

Liquid chromatography and tandem mass spectrometry detection (LC-MS/MS) was used to analyze a selected CSH possessing antioxidant and antimicrobial activity. Unless otherwise specified, all the equipment used was Agilent technologies brand (Santa Clara, CA, USA). The diluted CSH sample (5.7 mg/mL) was filtered through a 0.45  $\mu\text{m}$  filter paper and injected into a HPLC (1200 Series) equipped with a large capacity chip as the stationary phase (G4240/62010 160 nL enrichment, analytical 75  $\mu\text{m}$  x 150 mm, Zorbax 300SB-C18 5 $\mu\text{m}$ ) at 4  $\mu\text{L}/\text{min}$  flow rate. The mobile phase used in the HPLC was composed of a mixture of two solutions: solution A, 0.1 % Formic acid; and solution B, 90% acetonitrile with 0.1 % formic acid. The composition of the mobile phase changed throughout the injection time. From 0 to 2 min injection the mobile phase composition was 3% solution B and 97 % solution A; from 2 to 30 min it was 10% B and 90 % A; from 30 to 31 min 50% B and 50 % A; from 31 to 36 min 100% B; finally, from 36 to 40 min the mobile phase composition was 3% B and 97% A. Stop time was 40 min with a post-time of 10 min. The flow rate of the sample from the HPLC chip (stationary phase) toward the mass spectrometer (6520 Accurate-Mass Q-TOF LC/MS) was 0.40  $\mu\text{L}/\text{min}$ . The mass spec was operated in a range for peptide molecular weight/charge (m/z) ratio of 200 to 2000. The data from the LC-MS/MS was analyzed with the protein identification software Agilent Spectrum

Mill. Results included mass (m), charge (z), and partial sequences of the peptides found in the analyzed CSH sample.

### 3.2.12 Statistical analysis

Analyses were done in triplicate and the results were statistically analyzed by using Statistical Analysis System (SAS, Version 9.2, SAS Institute Inc., Cary, NC., USA). One-way or two-way analysis of variance (ANOVA) and Tukey's mean separation test were used to detect statistical differences ( $\alpha=0.05$ ).

## CHAPTER 4. RESULTS AND DISCUSSION

### 4.1 DH, pH, and Color of CSH

Table 1 shows the degree of hydrolysis (DH), pH, and color of catfish skin hydrolysates as a function of duration of hydrolysis.

**Table 1.** Degree of hydrolysis (DH), pH, and color of fresh CSH as a function of time of hydrolysis with alkaline protease.

Time of hydrolysis (h)	DH (%)	pH	Color		
			L	a	b
Initial	-	7.09±0.02 <sup>A</sup>	-	-	-
0.5	14.25±0.45 <sup>D</sup>	6.80± 0.02 <sup>B</sup>	54.12±0.43 <sup>AB</sup>	-2.09±0.11 <sup>B</sup>	6.11±0.16 <sup>D</sup>
1	16.83±1.13 <sup>CD</sup>	6.80± 0.02 <sup>B</sup>	54.77±1.64 <sup>A</sup>	-2.06±0.04 <sup>B</sup>	6.08±1.13 <sup>D</sup>
2	20.14±0.14 <sup>BC</sup>	6.72±0.01 <sup>C</sup>	53.63±0.46 <sup>AB</sup>	-2.12±0.05 <sup>B</sup>	6.95±0.38 <sup>D</sup>
3	20.59±2.56 <sup>BC</sup>	6.66±0.01 <sup>D</sup>	50.96±1.23 <sup>C</sup>	-1.99±0.08 <sup>B</sup>	9.98±0.89 <sup>C</sup>
4	22.78±2.21 <sup>AB</sup>	6.62±0.02 <sup>D</sup>	52.27±0.51 <sup>BC</sup>	-2.49±0.01 <sup>C</sup>	12.23±0.74 <sup>B</sup>
5	26.63±0.27 <sup>A</sup>	6.54±0.02 <sup>E</sup>	47.43±0.31 <sup>C</sup>	-1.74±0.06 <sup>A</sup>	13.77±0.47 <sup>B</sup>
6	26.65±1.36 <sup>A</sup>	6.48±0.03 <sup>F</sup>	47±0.12 <sup>D</sup>	-1.72±0.06 <sup>A</sup>	17.04±0.18 <sup>A</sup>

<sup>A-F</sup>Means±SD with no letters in common in the same column are significantly different (P<0.05)

The highest DH was registered after 5 h of enzymatic reaction with alkaline protease ( $26.65 \pm 1.36$  %). DH after 1 and 2 h in our study ( $16.83 \pm 1.13$  and  $20.14 \pm 0.14$  respectively) are in agreement with DH generated by alkaline protease on salmon and cod without pH modification (Liaset and others 2000). The initial pH of the homogenized catfish skin with distilled water was  $7.09 \pm 0.02$ , and it decreased through until a pH of  $6.48 \pm 0.03$  was obtained after 6 h of enzymatic hydrolysis. Significant changes ( $P < 0.05$ ) compared to the previous pH were observed after 0.5, 2, 3, 5, and 6 h of hydrolysis showing a tendency toward lower values. The generation of free protons as a result of low protonation of the amino group and high dissociation of the carboxyl group after the hydrolysis of peptide bonds may explain the tendency observed in the pH of CSH influenced by the duration of the hydrolysis (Adler-Nissen 1986).

Rapid initial hydrolysis was observed followed by a lower rate of hydrolysis. Similar patterns have been reported by other authors (Jia and others 2010; Liceaga-Gesualdo and Li-Chan 1999; Adler-Nissen 1986). This reduction of hydrolysis rate could be due to enzyme inhibition by hydrolysis products (Valencia and others 2014) which also reduces the recovery of soluble protein (Shahidi and others 1995).

The color of the CSH was affected by the extent of the hydrolysis. Longer hydrolysis times produced darker hydrolysates. This can be observed by a significant reduction ( $P < 0.05$ ) of the L value of the CSH generated at 3 and 6 h of enzymatic hydrolysis. The general tendency of L values was towards lower values, excepting the value obtained at 4 h hydrolysis. Darker color in CSH may be related to the oxidation of pigments naturally found in the skin such as myoglobin and melanin (Benjakul and Morrissey 1997; You and others 2009). A significant reduction ( $p > 0.05$ ) of the a value was observed in the hydrolysate obtained at 4 h of enzymatic hydrolysis; however, this value increased significantly ( $p < 0.05$ ) at 5 h of enzymatic hydrolysis compared to

the hydrolysates obtained at the immediately previous time of hydrolysis. On the other hand, opposite behavior was observed for the b value increasing significantly ( $p < 0.05$ ) at 3, 4, and 6 h of hydrolysis compared to the hydrolysates obtained at shorter times of hydrolysis. These changes in b value indicate the production of more yellow CSH which also was visually perceived.

#### **4.2 Proximate analysis and color of Freeze-dried CSH**

The proximate composition of the freeze-dried samples of CS and CSH generated as a function of hydrolysis is shown on Table 2. Compare to the CS composition, all the CSH had significantly ( $P < 0.05$ ) higher moisture, lower solids, higher protein, lower fat, and higher ash. The carbohydrate content of the CSH at 1 h of hydrolysis was significantly ( $P < 0.05$ ) higher than CS, and the rest of CSH were not significantly different ( $P > 0.05$ ) to CS. The moisture content of the CSH at 5 h of hydrolysis was significantly higher ( $P < 0.05$ ) than the CSH at 2 h. The opposite was observed for the solids content. Solid content of CSH at 2 h was significantly higher ( $P < 0.05$ ) than the CSH at 5 h. For both solids and moisture, CSH at 2 h and 5 h were not significantly different ( $P > 0.05$ ) to the rest of hydrolysates. CSH obtained at extended time of hydrolysis (5 and 6 h) had significantly lower ( $P < 0.05$ ) protein content than CSH at 0.5, 1, 2, and 4 h, and the CSH at 0.5 had significantly higher ( $P < 0.05$ ) protein content than CSH at 1 and 3 h of hydrolysis. It has been suggested that a reduction of the enzyme activity may be the cause of lower protein recovery at extended periods of hydrolysis (Valencia and others 2014; Shahidi and others 1995). The fat content showed a tendency to increase when the time of hydrolysis increased. The fat content of CSH at 2, 3, 5, and 6 h of hydrolysis was significantly higher ( $P < 0.05$ ) than the CSH at 0.5 h of hydrolysis; nevertheless, this latter was not significantly different ( $P > 0.05$ ) to the CSH at 1 and 4 h. No significant differences ( $P > 0.05$ ) in fat content were found among the CSH obtained at 1, 2, 3, 4, and 5 h of hydrolysis. The increase in fat

content of CSH throughout the time of hydrolysis could be due (in part) to the generation of peptides with better emulsion properties throughout the time of hydrolysis. It's likely that these peptides kept the fat in a stable emulsion which is supported by the emulsion stability results reported on section 4.4 of this document. No significant differences ( $P>0.05$ ) were observed for ash and carbohydrate among the CSH at the different times of hydrolysis.

**Table 2.** Proximate composition of freeze-dried catfish skin and proximate composition and color of freeze-dried CSH as a function of hydrolysis time.

Measurement	Catfish skin	Time of hydrolysis (h)						
		0.5	1	2	3	4	5	6
Moisture (%)	5.13±0.28 <sup>C</sup>	11.02±0.96 <sup>AB</sup>	12.20±0.20 <sup>AB</sup>	10.39±0.99 <sup>B</sup>	11.30±0.26 <sup>AB</sup>	10.99±0.61 <sup>AB</sup>	13.13±1.79 <sup>A</sup>	13.01±1.37 <sup>AB</sup>
Solids (%) <sup>1</sup>	94.87±0.28 <sup>A</sup>	88.98±0.96 <sup>BC</sup>	87.80±0.20 <sup>BC</sup>	89.61±0.99 <sup>B</sup>	88.70±0.26 <sup>BC</sup>	89.01±0.61 <sup>BC</sup>	86.87±1.79 <sup>C</sup>	86.99±1.37 <sup>BC</sup>
Protein (%) <sup>2</sup>	68.99±0.30 <sup>F</sup>	84.71±1.29 <sup>A</sup>	80.96±0.28 <sup>DC</sup>	83.67±1.67 <sup>ABC</sup>	81.82±0.39 <sup>BCD</sup>	83.74±0.39 <sup>AB</sup>	79.07±1.81 <sup>DE</sup>	77.73±1.11 <sup>E</sup>
Fat (%)	24.71±0.78 <sup>A</sup>	0.64±0.42 <sup>D</sup>	2.14±0.40 <sup>CD</sup>	3.57±1.38 <sup>BC</sup>	4.16±0.81 <sup>BC</sup>	1.78±1.01 <sup>CD</sup>	4.40±0.44 <sup>BC</sup>	5.10±1.55 <sup>B</sup>
Ash (%)	0.71±0.07 <sup>B</sup>	0.85±0.02 <sup>A</sup>	0.84±0.06 <sup>A</sup>	0.87±0.05 <sup>A</sup>	0.84±0.01 <sup>A</sup>	0.89±0.01 <sup>A</sup>	0.83±0.04 <sup>A</sup>	0.82±0.00 <sup>A</sup>
Carbohydrate (%) <sup>3</sup>	0.46±0.42 <sup>B</sup>	2.77±0.96 <sup>AB</sup>	3.86±0.43 <sup>A</sup>	1.50±1.42 <sup>AB</sup>	1.87±0.77 <sup>AB</sup>	2.60±0.94 <sup>AB</sup>	2.57±0.68 <sup>AB</sup>	3.34±1.75 <sup>AB</sup>
L	-	82.57±2.09 <sup>A</sup>	81.89±3.04 <sup>A</sup>	81.98±0.76 <sup>A</sup>	80.47±1.01 <sup>AB</sup>	78.83±1.16 <sup>AB</sup>	76.34±1.10 <sup>B</sup>	71.01±1.34 <sup>C</sup>
Color a	-	-0.55±0.05 <sup>A</sup>	-0.66±0.07 <sup>A</sup>	-0.60±0.03 <sup>A</sup>	-0.62±0.05 <sup>A</sup>	-0.69±0.05 <sup>A</sup>	-0.54±0.05 <sup>A</sup>	-0.92±0.09 <sup>B</sup>
b	-	4.72±0.43 <sup>D</sup>	5.23±1.93 <sup>D</sup>	5.02±0.17 <sup>CD</sup>	5.22±0.40 <sup>CD</sup>	6.16±0.32 <sup>BC</sup>	5.15±0.05 <sup>B</sup>	10.6±0.12 <sup>A</sup>

<sup>A-F</sup> Means±SD with no letters in common in the same row are significantly different (P<0.05)

<sup>1</sup>Values obtained by the subtraction of the moisture content from 100.

<sup>2</sup>Nitrogen value times 5.82.

<sup>3</sup>Values obtained by the subtraction of the protein, fat, and ash content from the total solids content.

The color of freeze-dried CSH showed similar tendency as the color of the CSH in solution. For the lightness, the values obtained for the CSH generated at 5 h of hydrolysis were significantly lower than those obtained for the CSH at 0.5, 1, and 2 h of hydrolysis. Moreover, the CSH obtained at 6 h of hydrolysis was darker than the rest of hydrolysates. As mentioned before, oxidation of pigments contributes to darker color of hydrolysates (Benjakul and Morrissey 1997; You and others 2009). Additionally, Maillard browning reaction (Wasswa and others 2007; Jemil and others 2014) and lipid oxidation (You and others 2009) may contribute to darker protein hydrolysates during hydrolysis. The fat content could be responsible (in part) for the increase of yellowness (higher “b” value) due to fat soluble pigments such as carotenoids (Walker and others 1990). Our CSH are lighter, more red, and less yellow (except the CSH at 6 h) compared to the CSH reported by Yin and others (2010).

#### **4.3 Free-Radical Scavenging Activity (FRSA)**

The FRSA of each CSH at 5 different concentrations is shown in Table 3. The results are expressed in millimol trolox equivalent per liter (mM Teq/L).

Negative values of FRSA were obtained at 0.5 h hydrolysis time for CSH concentrations of 50 mg/mL, at 1 h hydrolysis for concentrations equal of above of 100 mg/mL, and at 2 and 3 h for 200 and 250 mg/mL. All other values of FRSA were positive. However, the concentrations with negative FRSA values produced a visual change in color of the DPPH solution from purple to yellow. This change in color is caused by the reduction of the DPPH by antioxidants (Marxen and others 2007), but it was not detected in the spectrophotometer at 517 nm wavelength. This indicates the presence of compounds in the CSH causing interference in this colorimetric-UV method. It is known that antioxidants such as  $\alpha$ -tocopherol (Marxen and others 2007) and carotenoids (Britton 1995), and pigments found in plant extracts (Bhandari and others 2010) and food (Yamaguchi and others 1998) may interfere with the absorbance of DPPH leading to failure

in detection of changes in DPPH absorbance or producing higher values (Marxen and others 2007). Microscopic algae, which constitute a primary component of the ecosystem in a fish production pond (Brunson and others 1994), also contain pigments such as carotenoids that cause interference in the DPPH antioxidant analysis (Marxen and others 2007). Channel catfish can accumulate carotenoids (ex. lutein, zeaxanthin, canthaxanthin, and astaxanthin) in the skin when carotenoids are part of their diet (Li and others 2007), and this could be a possible source of interference in our results; however, it was not confirmed.

**Table 3.** FRSA (mM Teq/L) of different concentrations of CSH as a function of hydrolysis time (ToH).

ToH	CSH concentration in mg/mL of distilled water				
(h)	50	100	150	200	250
0.5	-64.83±19.94 <sup>Cc</sup>	-10.80±22.90 <sup>Bb</sup>	10.65±6.74 <sup>Bd</sup>	63.14±1.76 <sup>Ac</sup>	90.73±17.44 <sup>Ab</sup>
1	58.93±12.29 <sup>Aa</sup>	-83.98±24.71 <sup>Bc</sup>	-134.94±11.08 <sup>Cc</sup>	-145.67±19.72 <sup>Cf</sup>	-138.39±11.49 <sup>Ce</sup>
2	29.43±2.30 <sup>Ab</sup>	17.55±6.74 <sup>Ab</sup>	35.17±19.64 <sup>Ad</sup>	-87.82±35.07 <sup>Be</sup>	-170.19±11.51 <sup>Cf</sup>
3	63.91±5.01 <sup>Ca</sup>	107.59±3.04 <sup>Aa</sup>	83.83±11.57 <sup>Bc</sup>	-6.21±6.99 <sup>Dd</sup>	-72.11±1.76 <sup>Ed</sup>
4	59.31±1.99 <sup>Da</sup>	107.59±8.05 <sup>Ba</sup>	122.91±4.79 <sup>Ab</sup>	77.7±1.99 <sup>Cc</sup>	17.55±6.54 <sup>Ec</sup>
5	61.61±3.45 <sup>Da</sup>	131.34±0.66 <sup>Ca</sup>	169.66±6.40 <sup>Ba</sup>	193.03±4.79 <sup>Aa</sup>	162.38±5.43 <sup>Ba</sup>
6	54.33±4.65 <sup>Dab</sup>	132.11±4.04 <sup>Ba</sup>	163.14±19.55 <sup>Aa</sup>	133.64±2.89 <sup>Bb</sup>	105.29±2.30 <sup>Cb</sup>

<sup>A-E</sup> Means±SD with no letters in common within rows were significantly different (P<0.05)

<sup>a-f</sup> Means±SD with no letters in common within columns were significantly different (P<0.05)

The FRSA of the CSH was influenced by the time of hydrolysis. All the results for scavenging capacity obtained from CSH hydrolyzed for at least 4 h were positive for all of the concentrations. FRSA values were significantly higher (P<0.05) for hydrolyzed for 4 to 6 h than for CSH obtained at lower hydrolysis times except for the two lowest concentrations evaluated in



this experiment were used (50 and 100 mg CSH/mL distilled water). This is probably due to the higher quantity of protons generated during longer hydrolysis times, which is supported by the significant ( $P < 0.05$ ) reduction of the pH during the hydrolysis process. These protons could be neutralizing the DPPH free radicals during this antioxidant analysis.

The existence of a peak FRSA after certain time of hydrolysis and the decrease of FRSA after this peak has been reported previously for loach (You and others 2009), round scad (Thiansilakul and others 2007), and mackerel (Wu and others 2003) hydrolysates. This tendency is due (in part) to the hydrolysis of short peptides to a large quantity of free amino acids (Gbogouri and others 2004; Wu and others 2003; Benjakul and Morrissey 1997) during extended periods of hydrolysis. In the current study, the highest FRSA occurred for CSH with concentrations of 200 and 250 mg/mL at 5 h enzymatic hydrolysis followed by significantly lower ( $P < 0.05$ ) FRSA values at 6 h of hydrolysis. A similar effect (increase, peak, and decrease) was noted for the effect of concentration at a given hydrolysis time. The FRSA peak for the CSH generated at 3, 4, 5, and 6 h was at the concentration of 100, 150, 200, and 150 mg/mL respectively. A negative peak was observed at 1 h hydrolysis time for the concentration of 200 mg/mL while for CSH at 0.5 h increments in the concentration caused significant increments ( $P < 0.05$ ) in the FRSA value (excepting from 100 to 150 mg/mL concentration). No specific trend or peak was observed at 2 h hydrolysis time.

FRSA of hydrolysates has been linked to amino acid sequences as well as the constituent amino acids (Chen and others 1996). Proton-donation ability of certain amino acids such as histidine seems to favor the scavenging capacity of protein hydrolysates (Mendis and others 2005). In addition to amino acid composition and sequence, DH also affects the soluble protein recovery

which may change the concentration of peptides (Yasumatsu and others 1972) reducing FRSA of hydrolysates exposed to longer periods of hydrolysis (Thiansilakul and others 2007).

#### 4.4 Emulsion stability (ES) and oil holding capacity (OHC)

Results of ES and OHC of CSH are presented in Table 4. Increased degree of hydrolysis had a positive effect on the emulsion stability of CSH.

**Table 4.** Emulsion stability (ES) and oil holding capacity (OHC) of catfish skin hydrolysates influenced by the degree of hydrolysis.

Time of hydrolysis (h)	DH (%)	ES (%)	OHC (g retained oil/g CSH)
0.5	14.25±0.45 <sup>D</sup>	51.33±1.15 <sup>d</sup>	7.72±0.47 <sup>a</sup>
1	16.83±1.13 <sup>CD</sup>	54.00±2.00 <sup>d</sup>	7.69±0.39 <sup>a</sup>
2	20.14±0.14 <sup>BC</sup>	61.33±1.15 <sup>c</sup>	7.30±0.45 <sup>ab</sup>
3	20.59±2.56 <sup>BC</sup>	74.67±2.31 <sup>b</sup>	6.74±0.52 <sup>ab</sup>
4	22.78±2.21 <sup>AB</sup>	76.67±2.31 <sup>ab</sup>	6.17±0.24 <sup>bc</sup>
5	26.63±0.27 <sup>A</sup>	82.00±2.00 <sup>a</sup>	5.54±0.54 <sup>cd</sup>
6	26.65±1.36 <sup>A</sup>	77.33±2.31 <sup>ab</sup>	4.69±0.32 <sup>d</sup>

<sup>a-d</sup>Means±SD with with no letters in common in the same column are significantly different (P<0.05)

Maximum values of ES were 82.00±2.00% obtained after 5 h enzymatic hydrolysis with a DH of 26.63±0.27%. However, it was not significantly different (P>0.05) from the ES obtained by CSH produced at 4 and 6 h of hydrolysis probably influenced by the DH that also did not show significant differences (P>0.05) among these CSH. ES produced by the CSH obtained at 0.5, 1, and 2 h of hydrolysis was significantly lower (P<0.05) than the ES produced by CSH hydrolyzed for longer periods of time. Increases in the time of hydrolysis from 0.5 to 2, 2 to 3, and 3 to 5 h generated significant increments on the ES probably due to the generation of peptides of lower sizes throughout the time of hydrolysis able to migrate easier toward the interface in the

emulsion system. At  $14.25 \pm 0.45\%$  DH the ES produced by CSH was  $51.33 \pm 1.15\%$  in agreement with the value reported by Kristinsson and Rasco (2000a) (50%), higher than the values reported by Klompong and others (2007) (around 40%), and lower than the values reported by Shahidi and others (1995) (92%). Higher ES at lower DH (70% ES at 5 % DH) has been reported previously (Klompong and others 2007; Kristinsson and Rasco 2000a) may be due to bigger peptide size in the hydrolysate. In our study, 6 h of hydrolysis at a DH of  $26.65 \pm 1.36\%$  was not significantly different ( $P > 0.05$ ) from the ES generated by the CSH generated at 4 and 5 h of hydrolysis with DH of  $22.78 \pm 2.21\%$  and  $26.63 \pm 0.27\%$  respectively.

Reduced ES of the CSH produced at shorter times of hydrolysis could be due (in part) to both lower diffusion rate of peptides toward the interface (Conde and Patino 2007) and lower inter-molecules interaction (Liceaga-Gesualdo and Li-Chan 1999). On the other hand, longer periods of hydrolysis could reduce the ES due to a reduction in protein recovery at higher DH (Yasumatsu and others 1972). It may indicate that hydrolysates produced during the first 5 h of enzymatic reaction tend to migrate to the interface in O/W emulsions, unfold partially, re-orientate their hydrophilic and hydrophobic groups toward continuous and dispersed phase, and create a film layer through inter-molecular interactions around fat globules thus retaining emulsion stability as postulated by other authors (Lam and Nickerson 2013; Damodaran and others 2007; Yasumatsu and others 1972). The microstructure of the emulsion could help in the visualization of any difference in peptides at the interphase of the stable phase of this O/W emulsion.

OHC of CSH peaked at 0.5 h of hydrolysis ( $7.72 \pm 0.47$  g oil/g CSH our initial data point). There was a negative relationship between hydrolysis time and OHC with the lowest value of OHC ( $4.69 \pm 0.32$ ) obtained after 6 h (longest hydrolysis time) hydrolysis. This effect is in agreement

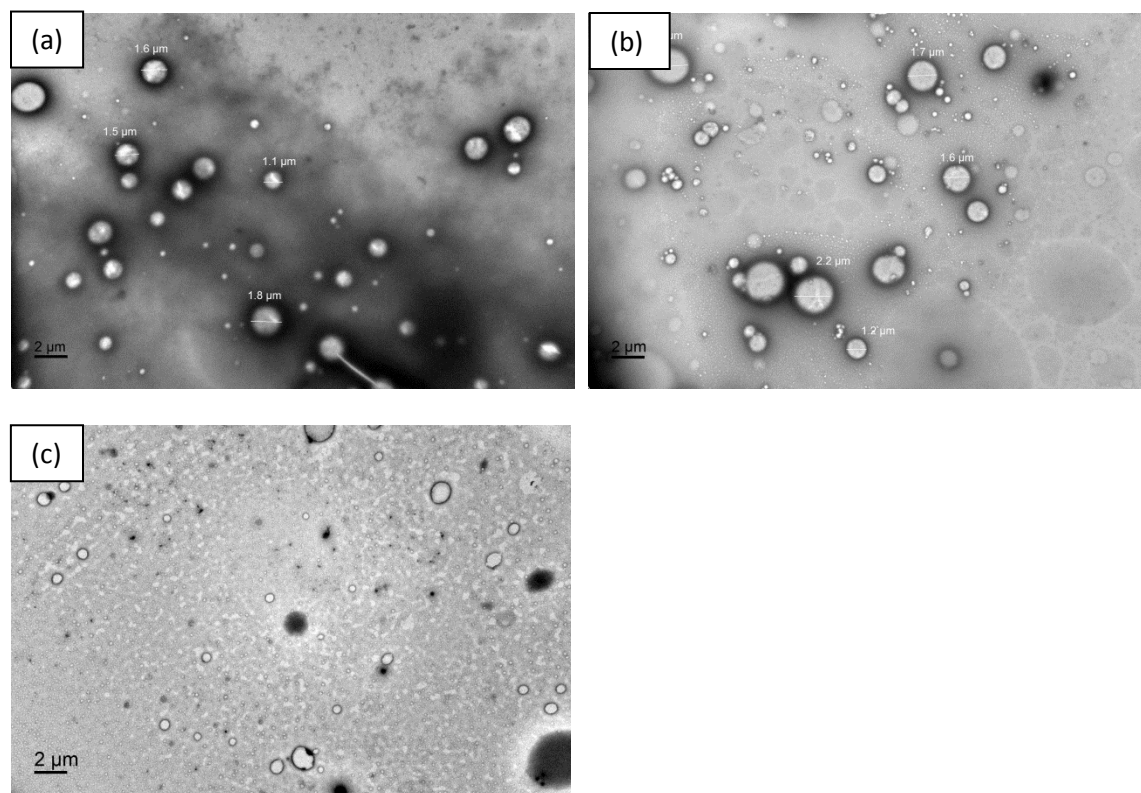
with the findings of other authors (Diniz and Martin 1997; Kristinsson and Rasco 2000a). The ability of proteins to hold fat has been chiefly linked to the protein's physical entrapment of oil (Zayas 1997). Thus the disruption of the protein network caused by the hydrolytic action of the enzyme could be an explanation for the reduction of OHC with hydrolysis time (Don and others 1991).

In a DH range of 10 to 18%, similar OHC has been reported for herring by-products hydrolysates (Sathivel and others 2003). Lower OHC was reported for capelin hydrolysates (Shahidi and others 1995). It should be noted that Sathivel and others (2003) also determined that, depending on the substrate, DH may have different effects on the OHC of a hydrolysate..

#### **4.5 Micro-structure of the emulsion's stable phase**

An attempt to visualize the microstructure of the oil and the CSH at the emulsion's interface was done by using transmission electron microscopy (TEM). Figure 4 contains images of the evaluated samples and the control.

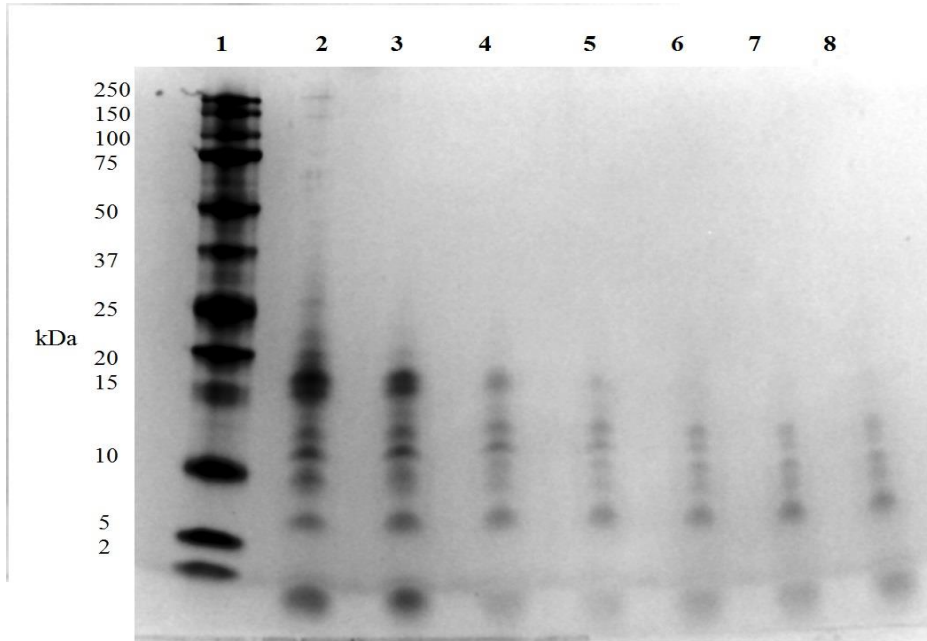
The microstructure of the emulsion when CSH generated at 0.5 and 6 h of hydrolysis was used as the emulsifier generated oil drops with diameters around 2  $\mu\text{m}$ . A dense dark layer surrounding the oil drops can be observed on Fig. 4 (a). This is due to the accumulation of the peptides around the oil drop suggested by the absence of this dark layer in the control (Fig. 4 (c)) and by the findings reported by other authors in emulsions where peptides were used as the emulsifier agent (Rosenberg and Lee 1993; Heertje and others 1996; Relkin and others 2006). This layer of peptides contributed to the stability of the emulsion when CSH at 6 h of hydrolysis time was used as the emulsifier. By forming a thick layer, adsorbed proteins (generally charged) can stabilize emulsion droplets by both steric repulsion and electrostatic (charge-repulsion) mechanisms (Dalgleish 2004).



**Fig. 4.** Micro-structure of the stable phase of the emulsions with highest (a) and lowest (b) emulsion stability obtained when using CSH 6 and CSH 0.5 as emulsifiers respectively. Control emulsion using Tween ® 20 with no CSH addition (c).

On the other hand, oil drops of bigger diameters are observed on Fig. 4 (b) where CSH at 0.5 h of hydrolysis time was used as the emulsifier. As in the previous case, a dark layer is observed surrounding the oil drops; however, this layer is not as dense as it is on Fig. 4 (a). The result of coalescence of several small and big oil drops is also observed on Fig. 4 (b). The instability of the emulsion when the CSH obtained at 0.5 h hydrolysis was used as the emulsifier was probably due to a lower migration of the peptides toward the interphase which is supported by the lower density of the dark layer surrounding the oil drops. Thicker dark layer surrounding the oil drop suggests higher migration of the peptides toward the emulsion interphase when CSH at 6 h of hydrolysis time was used as the emulsifier, which could be the explanation (in part) to the higher emulsion stability.

## 4.6 SDS-PAGE



**Fig. 5.** SDS-PAGE profile of catfish skin hydrolysates and SDS marker. Where column 1= SDS marker; column 2 to 8= CSH after 0.5, 1, 2, 3, 4, 5, and 6 h enzymatic hydrolysis respectively.

Rapid degradation of protein to intermediate peptides occurs during hydrolysis (Adler-Nissen and Olsen 1979). This results in molecules (peptides) with different MW in CSH after different enzymatic reaction times. Figure 5 shows the presence of high MW molecules after 0.5 h enzymatic reaction. Faint bands located around 150 and 250 kDa can be observed at this point, and highly marked bands at 15 to 20 kDa indicating that a large quantity of large molecules associated with these bands are present in the CSH after 30 min hydrolysis. However, these highly marked bands become faint after 3 h of hydrolysis, and they are not observed after 4 h of hydrolysis. The last 3 columns on the gel (4, 5, and 6 h) indicate that the protein/polypeptides found initially on CS have been hydrolyzed to smaller molecules of around 10 kDa MW or below which is in accord with the observations reported by Yin and others (2010). Bands near 250 and 100 kDa may correspond to  $\beta$  and  $\alpha$  collagen chains respectively (Singh and others

2011). Some of those collagen chains have been hydrolyzed after 0.5 h, and have disappeared after 1 h. Other authors have reported similar fish protein hydrolysates MW profiles (Sathivel and others 2008; Kristinsson and Rasco 2000a; Benjakul and Morrissey 1997).

#### 4.7 Agar-disk diffusion

Antimicrobial functions of sterilized and non-sterilized solutions (200 mg/mL) of CSH produced at 4, 5, and 6 h of hydrolysis were tested for *S. aureus*, *L. monocytogenes*, and *B. cereus* (Gram positive) and *E. coli* 0157: H7 (Gram negative). Results were classified as “+” for CSH with antimicrobial effect, “-” for CSH with no antimicrobial effect, and “\*” when the CSH effectiveness was not clear. The antimicrobial effect was confirmed by the presence of an inhibition zone.

**Table 5.** Antimicrobial effect of sterilized and non-sterilized CSH obtained at different time of hydrolysis over gram positive and gram negative bacteria.

		Time of hydrolysis of CSH (h)					
		4		5		6	
Bacteria		S <sup>1</sup>	NS <sup>2</sup>	S <sup>1</sup>	NS <sup>2</sup>	S <sup>1</sup>	NS <sup>2</sup>
	<i>S. aureus</i>	-	-	+	+	+	+
Gram positive	<i>L. monocytogenes</i>	*	*	*	*	*	*
	<i>B. cereus</i>	-	-	+	+	-	-
Gram negative	<i>E. coli</i> 0157:H7	+	+	+	+	+	+

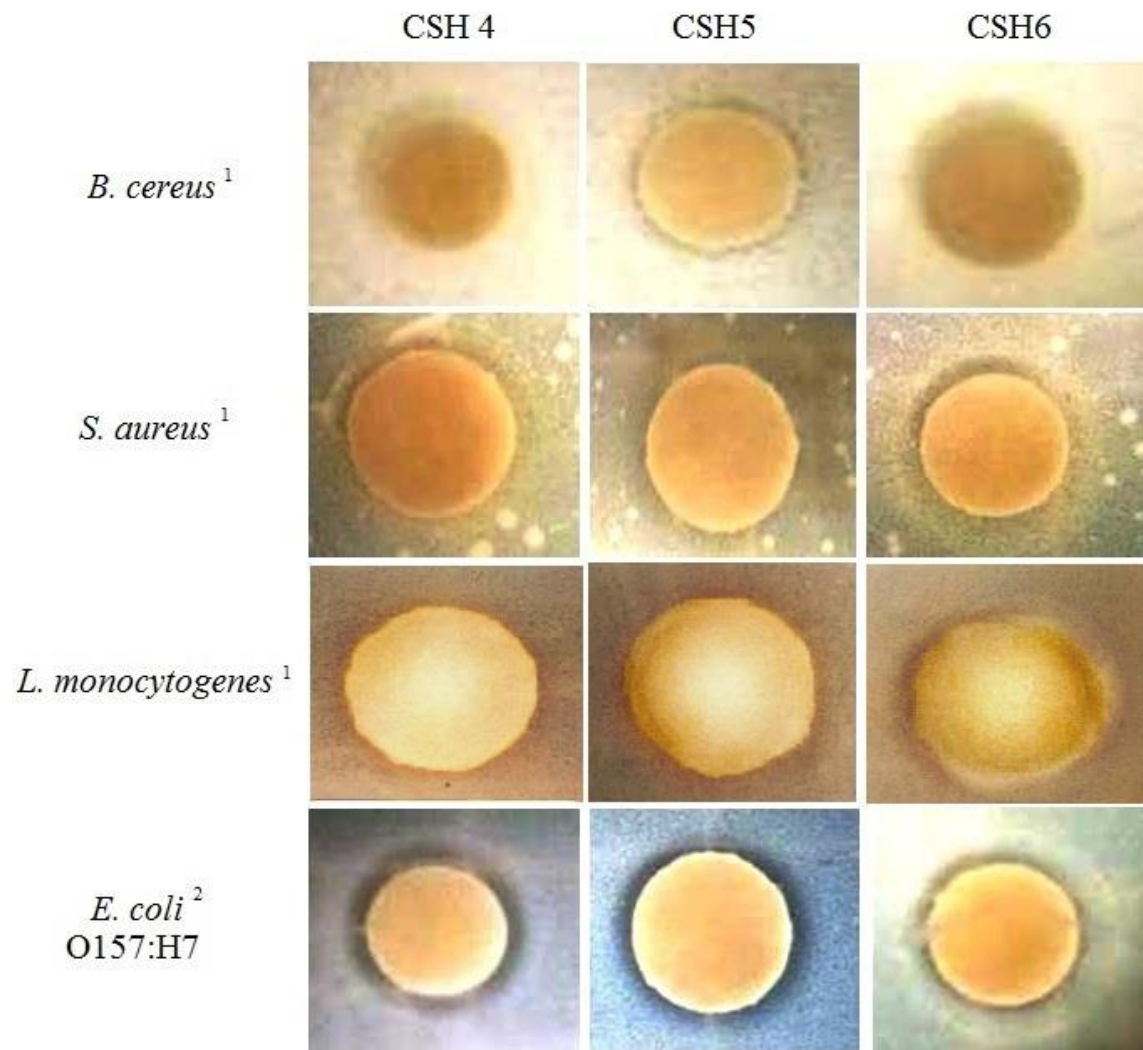
<sup>1</sup>Sterilized; <sup>2</sup>Non-sterilized; <sup>(+)</sup>Antimicrobial effect; <sup>(-)</sup>No antimicrobial effect; <sup>(\*)</sup> Not definitive.

Our results indicate that the CSH generated at 5 h of hydrolysis had antimicrobial activity against 3 of the 4 used bacteria, including both Gram positive and Gram negative microorganisms. This antimicrobial effect was not eliminated by the sterilization of the CSH solution (121 °C for 15

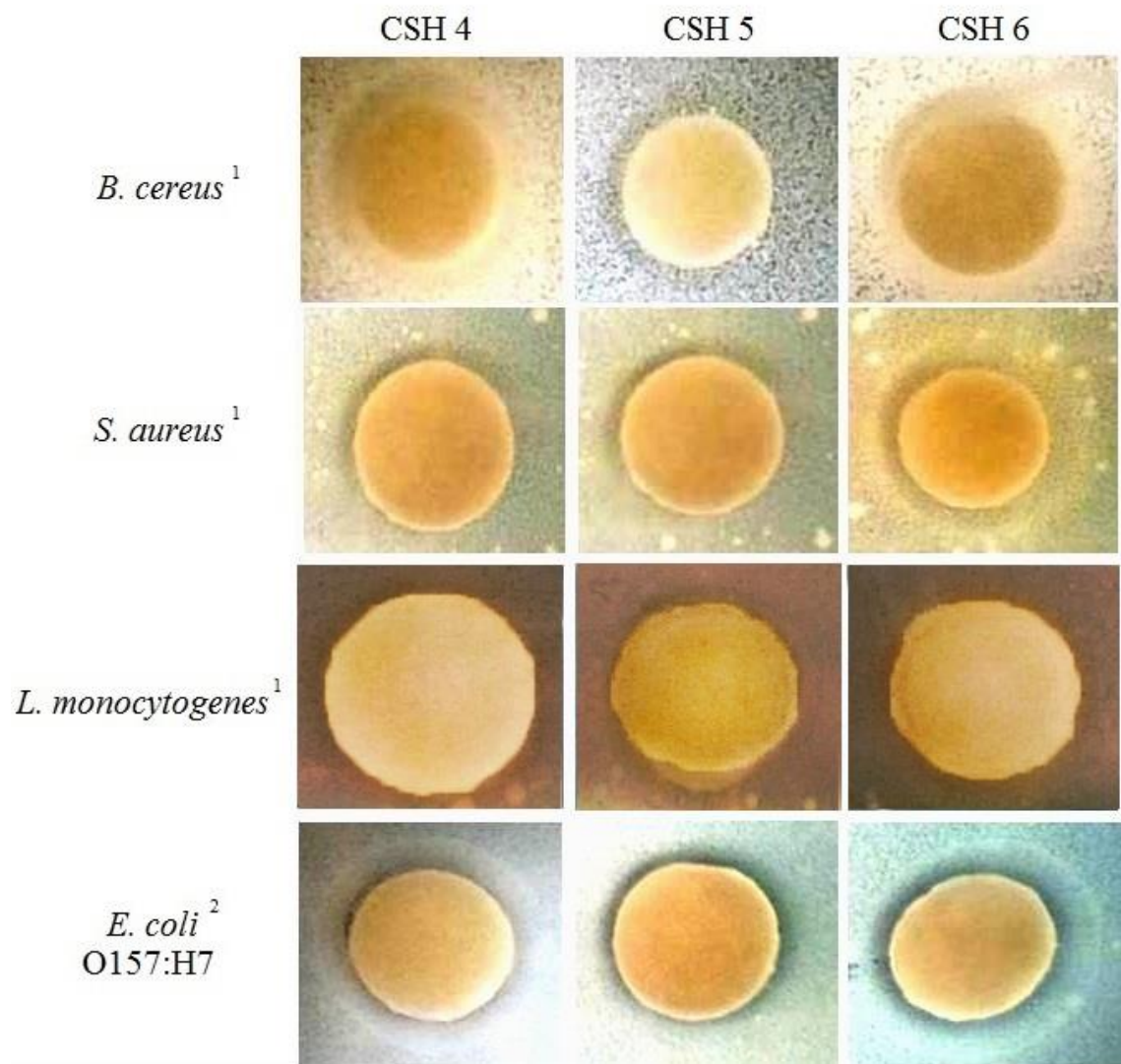
min). The CSH generated at 4 h of did not exhibit antimicrobial activity against gram positive bacteria, but it did against *E. coli*, and similar to the CSH at 5 h of hydrolysis, the sterilization process did not eliminate this property for this particular bacterium. The solution of CSH generated at 6 h of hydrolysis sterilized and non-sterilized showed antimicrobial activity against *S. aureus* and *E. coli*, but not against *B. cereus*. Peptides of low molecular weight (less than 20 kilo Daltons) have been associated with antimicrobial activity (Gobinath and Ravichandran 2011; Salampessy and others 2010; Bergsson and others 2005; Robinette and others 1998). As explained before, cellular lysis due to the perforation of the bacteria's membrane by positive charged peptides could be the cause of the antimicrobial effect of the hydrolysates (Brogden 2005; Bessalle and others 1992).

Figure 6 contains pictures of the disks used for the disk inhibition assay when solutions of filtered-non-sterilized CSH at 4, 5, and 6 h of hydrolysis were evaluated as antimicrobials against gram positive (*B. cereus*, *S. aureus*, and *L. monocytogenes*) and gram negative (*E. coli* O157:H7) bacteria. Figure 7 contains pictures of the disks of the same analysis when solutions of filtered-sterilized CSH at 4, 5, and 6 h of hydrolysis were evaluated as antimicrobials against the bacteria mentioned before. For both figures, a halo was observed around the disks containing CSH with antimicrobial capacity. This halo was generated as result of bacterial growth inhibition. The white lines on the pictures of *L. monocytogenes* are not relevant for our results. These lines belong to the surface over which the Petrie dish was placed for taking the picture.



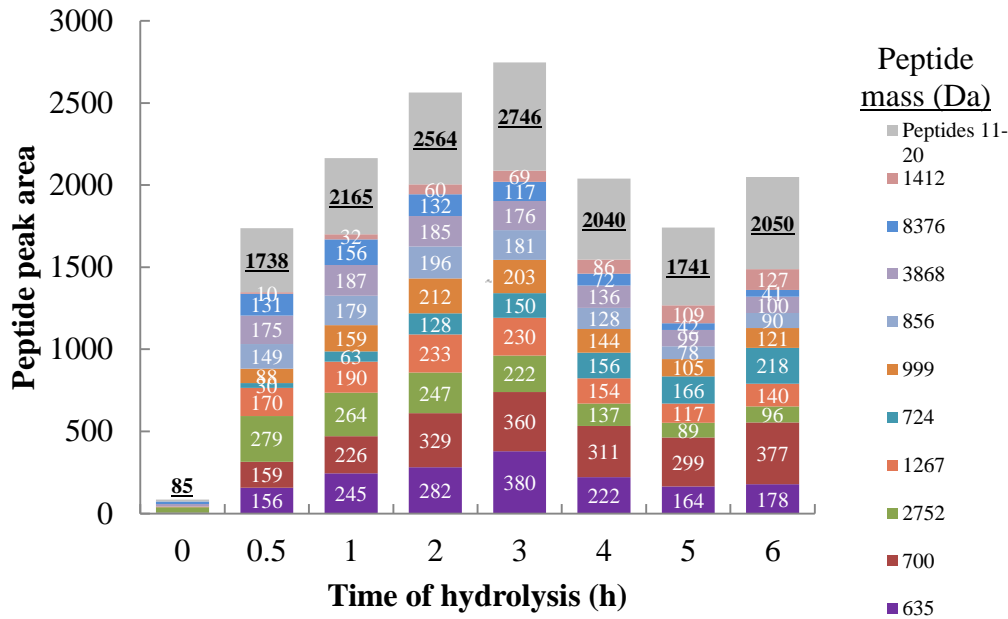


**Fig. 6.** Disk inhibition assay of filtered-non-sterilized CSH solutions (250 mg/mL) at 4, 5, and 6 h of hydrolysis as antimicrobials against Gram positive<sup>1</sup> and Gram negative<sup>2</sup> bacteria.



**Fig. 7.** Disk inhibition assay of filtered-sterilized CSH solutions (250 mg/mL) at 4, 5, and 6 h of hydrolysis as antimicrobials against Gram positive<sup>1</sup> and Gram negative<sup>2</sup> bacteria.

#### 4.8 Peptides production during hydrolysis



**Fig. 8.** Peak area profile of the 10 peptides with largest area generated during CS hydrolysis. Numbers in the bars represent the peak area for each peptide. The top gray bar represents the second set of 10 peptides and the underlined number is the total peptide peak area for the top 20 peptides.

The chromatogram in Fig. 8 shows that several peptides were generated after the first period of hydrolysis (0.5 h). The control contained mainly only 3 peptides in low quantities. The major control peak, with a mass of 2748 Da, increased to its maximum during the first 0.5 h hydrolysis, and slowly decreased over the remaining 6 h of hydrolysis, probably due to the proteolytic action of the alkaline enzyme, generating several new peaks. This 2748 Da peptide was multiply charged (+4), and the other large peptides (3864 and 8364) with multiple charges (+4 and +8, respectively) also showed a similar maximum peptide area at 0.5-1 h hydrolysis time. All other new peptides were singly charged and increased in area over time, with the maximum area

occurring at 2-3 h for masses 634, 1266, 998, 855, and 1410, while masses 699 and 723 were continuing to increase in area at the last (6 h) hydrolysis time point.

The CSH produced at 5 h of hydrolysis was selected for the identification of peptides on its composition. The molecular weight, positive charges, and partial sequencing were determined, and the results are shown below. In the next section, CSH<sub>5</sub> was used for making reference to the CSH generated at 5 h of hydrolysis.

#### 4.9 Peptide molecular weight (MW) distribution, charge profile, and partial sequencing

Tandem mass spectrometry results showed the presence of 223 peptides of low-molecular weight in CSH<sub>5</sub>.

**Table 6.** Molecular weight (MW) distribution of peptides detected in CSH<sub>5</sub>.

MW (Daltons)	# of peptides	%
500-1000	35	15.70
>1000-2000	84	37.67
>2000-3000	63	28.25
>3000	41	18.39
<b>Total</b>	<b>223</b>	<b>100</b>

Table 6 shows that CSH<sub>5</sub> had a large quantity of short peptides. More than 80% of the peptides found have less than 3 kDa MW. Similar peptide MW distribution was reported by You and others (2009) on loach protein hydrolysates at similar DH and Ketnawa and others (2016) on gelatin hydrolysates at lower DH. Protein hydrolysates with a large content of short peptides (<3 kDa) have been reported as being potential antimicrobials (Wald and others 2016). Furthermore, isolated peptides from this range of molecular weight have shown strong antimicrobial capacity (Mendis and others 2005).

The identification of the number of positive charges on the peptides detected on CSH<sub>5</sub> reveals that more than 95% of CSH<sub>5</sub> peptides have charges in a range of +2 to +6, which can be observed from Table 7. Dathe and others (2001) and Bessalle and others (1992) have linked peptides with charges  $\geq +2$  to antimicrobial activity and selectivity enhancement. Cationic peptides with 2 to 9 positive charges have been linked to antimicrobial activity by Yeaman and Yount (2003). Thus, CSH<sub>5</sub> is expected to have antimicrobial activity.

**Table 7.** Peptides as a function of their net charge in CSH<sub>5</sub>.

# of positive charges in the peptide	# of peptides	%
1	10	4.48
2	115	51.57
3	63	28.25
4	26	11.66
5	8	3.59
6	1	0.45
<b>Total</b>	<b>223</b>	<b>100</b>

It was not possible to identify the amino acid sequences of these peptides.

## CHAPTER 5. SUMMARY CONCLUSIONS

The study was designed to develop and characterize catfish skin hydrolysates including antioxidant and antimicrobial properties. The objective was reached with the enzymatic treatment of catfish skin for 4, 5, and 6 h using alkaline protease. This process generated hydrolysates with both antioxidant and antimicrobial properties. All the CSH generated at different time of hydrolysis possessed functional properties such as emulsifying stability and oil holding capacity of some extent. These properties were influenced by the time of hydrolysis.

Low-molecular weight peptides seem to be responsible for the antimicrobial capacity of the CSH at 4, 5, and 6 h of hydrolysis time. These results suggest a potential for CSH as a functional product in the food industry.

## CHAPTER 6. REFERENCES

- Adler-Nissen J. 1986. Enzymic hydrolysis of food proteins: Elsevier Applied Science Publishers.
- Adler-Nissen J, Olsen HS. 1979. The influence of peptide chain length on taste and functional properties of enzymatically modified soy protein.
- Amarowicz R. 2010. Modification of emulsifying properties of food proteins by enzymatic hydrolysis. *European journal of lipid science and technology* 112(7):695-6.
- Amarowicz R, Shahidi F. 1997. Antioxidant activity of peptide fractions of capelin protein hydrolysates. *Food Chemistry* 58(4):355-9.
- Anwar A, Saleemuddin M. 1998. Alkaline proteases: a review. *Bioresource Technology* 64(3):175-83.
- AOAC. 1995. Official methods of analysis of AOAC International. Arlington, Va: AOAC International.
- Argue BJ, Liu Z, Dunham RA. 2003. Dress-out and fillet yields of channel catfish, *Ictalurus punctatus*, blue catfish, *Ictalurus furcatus*, and their F 1, F 2 and backcross hybrids. *Aquaculture* 228(1):81-90.
- Benjakul S, Morrissey MT. 1997. Protein hydrolysates from Pacific whiting solid wastes. *Journal of Agricultural and Food Chemistry* 45(9):3423-30.
- Bergsson G, Agerberth B, Jörnvall H, Gudmundsson GH. 2005. Isolation and identification of antimicrobial components from the epidermal mucus of Atlantic cod (*Gadus morhua*). *Febs Journal* 272(19):4960-9.
- Bessalle R, Haas H, Gorla A, Shalit I, Fridkin M. 1992. Augmentation of the antibacterial activity of magainin by positive-charge chain extension. *Antimicrobial agents and chemotherapy* 36(2):313-7.

- Bhandari P, Kumar N, Singh B, Ahuja PS. 2010. Online HPLC-DPPH method for antioxidant activity of *Picrorhiza kurroa* Royle ex Benth. and characterization of kutkoside by Ultra-Performance LC-electrospray ionization quadrupole time-of-flight mass spectrometry.
- Biesalski H-K, Dragsted LO, Elmadfa I, Grossklaus R, Müller M, Schrenk D, Walter P, Weber P. 2009. Bioactive compounds: definition and assessment of activity. *Nutrition* 25(11):1202-5.
- Britton G. 1995. Structure and properties of carotenoids in relation to function. *The FASEB Journal* 9(15):1551-8.
- Brogden KA. 2005. Antimicrobial peptides: pore formers or metabolic inhibitors in bacteria? *Nature Reviews Microbiology* 3(3):238-50.
- Brunson MW, Lutz CG, Durborow RM. 1994. Algae blooms in commercial fish production ponds: Southern Regional Aquaculture Center.
- Chalamaiah M, Hemalatha R, Jyothirmayi T. 2012. Fish protein hydrolysates: proximate composition, amino acid composition, antioxidant activities and applications: a review. *Food Chemistry* 135(4):3020-38.
- Chen H-M, Muramoto K, Yamauchi F, Nokihara K. 1996. Antioxidant activity of designed peptides based on the antioxidative peptide isolated from digests of a soybean protein. *Journal of agricultural and food chemistry* 44(9):2619-23.
- Clement S, Lovell R. 1994. Comparison of processing yield and nutrient composition of cultured Nile tilapia (*Oreochromis niloticus*) and channel catfish (*Ictalurus punctatus*). *Aquaculture* 119(2):299-310.



- Conde JM, Patino JMR. 2007. The effect of enzymatic treatment of a sunflower protein isolate on the rate of adsorption at the air–water interface. *Journal of Food Engineering* 78(3):1001-9.
- Dalgleish DG. 2004. Food emulsions: their structures and properties. *Food emulsions*:1-44.
- Damodaran S, Parkin KL, Fennema OR. 2007. *Fennema's food chemistry*: CRC press.
- Dathe M, Nikolenko H, Meyer J, Beyermann M, Bienert M. 2001. Optimization of the antimicrobial activity of magainin peptides by modification of charge. *FEBS letters* 501(2-3):146-50.
- Dathe M, Wieprecht T, Nikolenko H, Handel L, Maloy WL, MacDonald DL, Beyermann M, Bienert M. 1997. Hydrophobicity, hydrophobic moment and angle subtended by charged residues modulate antibacterial and haemolytic activity of amphipathic helical peptides. *Febs Letters* 403(2):208-12.
- Di Bernardini R, Harnedy P, Bolton D, Kerry J, O'Neill E, Mullen AM, Hayes M. 2011. Antioxidant and antimicrobial peptidic hydrolysates from muscle protein sources and by-products. *Food Chemistry* 124(4):1296-307.
- Diniz F, Martin A. 1997. Effects of the extent of enzymatic hydrolysis on functional properties of shark protein hydrolysate. *LWT-Food Science and Technology* 30(3):266-72.
- Don LB, Pilosof A, Bartholomai G. 1991. Enzymatic modification of soy protein concentrates by fungal and bacterial proteases. *Journal of the American Oil Chemists Society* 68(2):102-5.
- Elavarasan K, Naveen Kumar V, Shamasundar B. 2014. Antioxidant and functional properties of fish protein hydrolysates from fresh water carp (*Catla catla*) as influenced by the nature of enzyme. *Journal of Food Processing and Preservation* 38(3):1207-14.

- Gbogouri G, Linder M, Fanni J, Parmentier M. 2004. Influence of hydrolysis degree on the functional properties of salmon byproducts hydrolysates. *Journal of food science* 69(8):C615-C22.
- Ghaly AE, Dave D, Budge S, Brooks M. 2010. Fish spoilage mechanisms and preservation techniques: review. *American Journal of Applied Sciences* 7(7):859.
- Gobinath RAC, Ravichandran S. 2011. Antimicrobial peptide from the epidermal mucus of some estuarine cat fishes. *World Applied Sciences Journal* 12(3):256-60.
- Gómez-Guillén M, Giménez B, López-Caballero Ma, Montero M. 2011. Functional and bioactive properties of collagen and gelatin from alternative sources: A review. *Food Hydrocolloids* 25(8):1813-27.
- Hanson T, Sites MD. 2015. 2014 US Catfish database. *Fisheries*.
- Heertje I, Van Aalst H, Blonk J, Don A, Nederlof J, Lucassen-Reynders E. 1996. Observations on emulsifiers at the interface between oil and water by confocal scanning light microscopy. *LWT-Food Science and Technology* 29(3):217-26.
- Himaya S, Kim S-K. 2014. Functional Proteins and Peptides from Fish Skin. *Seafood Processing By-Products*: Springer. p. 197-205.
- Huang D, Ou B, Prior RL. 2005. The chemistry behind antioxidant capacity assays. *Journal of agricultural and food chemistry* 53(6):1841-56.
- Jamilah B, Tan K, Hartina MU, Azizah A. 2011. Gelatins from three cultured freshwater fish skins obtained by liming process. *Food hydrocolloids* 25(5):1256-60.
- Jang A, Jo C, Kang K-S, Lee M. 2008. Antimicrobial and human cancer cell cytotoxic effect of synthetic angiotensin-converting enzyme (ACE) inhibitory peptides. *Food Chemistry* 107(1):327-36.

- Jang A, Lee M. 2005. Purification and identification of angiotensin converting enzyme inhibitory peptides from beef hydrolysates. *Meat Science* 69(4):653-61.
- Je J-Y, Park P-J, Kim S-K. 2005. Antioxidant activity of a peptide isolated from Alaska pollack (*Theragra chalcogramma*) frame protein hydrolysate. *Food Research International* 38(1):45-50.
- Je J-Y, Qian Z-J, Byun H-G, Kim S-K. 2007. Purification and characterization of an antioxidant peptide obtained from tuna backbone protein by enzymatic hydrolysis. *Process Biochemistry* 42(5):840-6.
- Jemil I, Jridi M, Nasri R, Ktari N, Salem RBS-B, Mehiri M, Hajji M, Nasri M. 2014. Functional, antioxidant and antibacterial properties of protein hydrolysates prepared from fish meat fermented by *Bacillus subtilis* A26. *Process Biochemistry* 49(6):963-72.
- Jia J, Zhou Y, Lu J, Chen A, Li Y, Zheng G. 2010. Enzymatic hydrolysis of Alaska pollack (*Theragra chalcogramma*) skin and antioxidant activity of the resulting hydrolysate. *Journal of the Science of Food and Agriculture* 90(4):635-40.
- Kato A, Nakai S. 1980. Hydrophobicity determined by a fluorescence probe method and its correlation with surface properties of proteins. *Biochimica et biophysica acta (BBA)-Protein structure* 624(1):13-20.
- Kato S, Matsui H, Saitoh Y, Miwa N. 2011. Fish collagen-containing drink is subcutaneously absorbed and attenuates the UVA-induced tissue-integrity destruction and DNA damages in 3D-human skin tissue model. *Journal of Functional Foods* 3(1):50-5.
- Ketnawa S, Martínez-Alvarez O, Benjakul S, Rawdkuen S. 2016. Gelatin hydrolysates from farmed Giant catfish skin using alkaline proteases and its antioxidative function of simulated gastro-intestinal digestion. *Food chemistry* 192:34-42.

- Klompong V, Benjakul S, Kantachote D, Shahidi F. 2007. Antioxidative activity and functional properties of protein hydrolysate of yellow stripe trevally (*Selaroides leptolepis*) as influenced by the degree of hydrolysis and enzyme type. *Food chemistry* 102(4):1317-27.
- Korhonen H, Pihlanto A. 2006. Bioactive peptides: production and functionality. *International dairy journal* 16(9):945-60.
- Kristinsson HG, Rasco BA. 2000a. Biochemical and functional properties of Atlantic salmon (*Salmo salar*) muscle proteins hydrolyzed with various alkaline proteases. *Journal of agricultural and food chemistry* 48(3):657-66.
- Kristinsson HG, Rasco BA. 2000b. Fish protein hydrolysates: production, biochemical, and functional properties. *Critical reviews in food science and nutrition* 40(1):43-81.
- Lam RS, Nickerson MT. 2013. Food proteins: a review on their emulsifying properties using a structure–function approach. *Food Chemistry* 141(2):975-84.
- Li-Chan E, Nakai S, Wood D. 1985. Relationship between functional (fat binding, emulsifying) and physicochemical properties of muscle proteins. Effects of heating, freezing, pH and species. *Journal of Food Science* 50(4):1034-40.
- Li MH, Robinson EH, Oberle DF, Zimba PV. 2007. Effects of various dietary carotenoid pigments on fillet appearance and pigment absorption in channel catfish, *Ictalurus punctatus*. *Journal of the World Aquaculture Society* 38(4):557-63.
- Liaset B, Lied E, Espe M. 2000. Enzymatic hydrolysis of by-products from the fish-filleting industry; chemical characterisation and nutritional evaluation. *Journal of the Science of Food and Agriculture* 80(5):581-9.
- Liceaga-Gesualdo A, Li-Chan E. 1999. Functional properties of fish protein hydrolysate from herring (*Clupea harengus*). *Journal of Food Science* 64(6):1000-4.

- Marcuse R. 1962. The effect of some amino acids on the oxidation of linoleic acid and its methyl ester. *Journal of the American Oil Chemists Society* 39(2):97-103.
- Marxen K, Vanselow KH, Lippemeier S, Hintze R, Ruser A, Hansen U-P. 2007. Determination of DPPH radical oxidation caused by methanolic extracts of some microalgal species by linear regression analysis of spectrophotometric measurements. *Sensors* 7(10):2080-95.
- McDonald JK. 1985. An overview of protease specificity and catalytic mechanisms: aspects related to nomenclature and classification. *The Histochemical Journal* 17(7):773-85.
- Mendis E, Rajapakse N, Kim S-K. 2005. Antioxidant properties of a radical-scavenging peptide purified from enzymatically prepared fish skin gelatin hydrolysate. *Journal of agricultural and food chemistry* 53(3):581-7.
- Najafian L, Babji AS. 2012. A review of fish-derived antioxidant and antimicrobial peptides: their production, assessment, and applications. *Peptides* 33(1):178-85.
- NASS. 2013. *Catfish Processing*. United States: United States Department of Agriculture.
- NASS. 2016. *Catfish production*. United States Department of Agriculture.
- Ngo D-H, Qian Z-J, Ryu B, Park JW, Kim S-K. 2010. In vitro antioxidant activity of a peptide isolated from Nile tilapia (*Oreochromis niloticus*) scale gelatin in free radical-mediated oxidative systems. *Journal of Functional Foods* 2(2):107-17.
- Nielsen P, Petersen D, Dambmann C. 2001. Improved method for determining food protein degree of hydrolysis. *Journal of food science* 66(5):642-6.
- Nikoo M, Benjakul S. 2015. Potential application of seafood-derived peptides as bifunctional ingredients, antioxidant–cryoprotectant: A review. *Journal of Functional Foods* 19:753-64.
- NMFS. 2014. *Fisheries of the United States*. National Marine Fisheries Service.

- Panyam D, Kilara A. 1996. Enhancing the functionality of food proteins by enzymatic modification. *Trends in food science & technology* 7(4):120-5.
- Qian Z-J, Jung W-K, Kim S-K. 2008. Free radical scavenging activity of a novel antioxidative peptide purified from hydrolysate of bullfrog skin, *Rana catesbeiana* Shaw. *Bioresource Technology* 99(6):1690-8.
- Rajapakse N, Mendis E, Jung W-K, Je J-Y, Kim S-K. 2005. Purification of a radical scavenging peptide from fermented mussel sauce and its antioxidant properties. *Food Research International* 38(2):175-82.
- Relkin P, Sourdet S, Smith A, Goff H, Cuvelier G. 2006. Effects of whey protein aggregation on fat globule microstructure in whipped-frozen emulsions. *Food hydrocolloids* 20(7):1050-6.
- Robinette D, Wada S, Arroll T, Levy M, Miller W, Noga E. 1998. Antimicrobial activity in the skin of the channel catfish *Ictalurus punctatus*: characterization of broad-spectrum histone-like antimicrobial proteins. *Cellular and Molecular Life Sciences CMLS* 54(5):467-75.
- Roller S. 1995. The quest for natural antimicrobials as novel means of food preservation: status report on a European research project. *International biodeterioration & biodegradation* 36(3):333-45.
- Rosenberg M, Lee S. 1993. Microstructure of whey protein/anhydrous milkfat emulsions. *Food Structure* 12(2):14.
- Salampessy J, Phillips M, Seneweera S, Kailasapathy K. 2010. Release of antimicrobial peptides through bromelain hydrolysis of leatherjacket (*Meuschenia* sp.) insoluble proteins. *Food Chemistry* 120(2):556-60.

- Sarmadi BH, Ismail A. 2010. Antioxidative peptides from food proteins: a review. *Peptides* 31(10):1949-56.
- Sathivel S, Bechtel P, Babbitt J, Smiley S, Crapo C, Reppond K, Prinyawiwatkul W. 2003. Biochemical and functional properties of herring (*Clupea harengus*) byproduct hydrolysates. *Journal of Food Science* 68(7):2196-200.
- Sathivel S, Huang J, Bechtel PJ. 2008. Properties of pollock (*Theragra chalcogramma*) skin hydrolysates and effects on lipid oxidation of skinless pink salmon (*Oncorhynchus gorbuscha*) fillets during 4 months of frozen storage. *Journal of food biochemistry* 32(2):247-63.
- Severin S, Xia W. 2006. Enzymatic hydrolysis of whey proteins by two different proteases and their effect on the functional properties of resulting protein hydrolysates. *Journal of Food Biochemistry* 30(1):77-97.
- Shahidi F, Han X-Q, Synowiecki J. 1995. Production and characteristics of protein hydrolysates from capelin (*Mallotus villosus*). *Food chemistry* 53(3):285-93.
- Shoulders MD, Raines RT. 2009. Collagen structure and stability. *Annual review of biochemistry* 78:929.
- Silva JL, Dean S. 2001. Processed catfish product forms, packaging, yields and product mix.
- Singh P, Benjakul S, Maqsood S, Kishimura H. 2011. Isolation and characterisation of collagen extracted from the skin of striped catfish (*Pangasianodon hypophthalmus*). *Food Chemistry* 124(1):97-105.
- Šližytė R, Daukšas E, Falch E, Storrø I, Rustad T. 2005. Characteristics of protein fractions generated from hydrolysed cod (*Gadus morhua*) by-products. *Process Biochemistry* 40(6):2021-33.

- Smitherman RO, Dunham R. 1993. Relationships among cultured and naturally occurring populations of freshwater catfish in the United States. Interactions Between Cultured Species and Naturally Occurring Species in the Environment, Homer, Alaska, Elmer E. Rasmuson Library Cataloging-In-Publication.
- Sosulski FW, Imafidon GI. 1990. Amino acid composition and nitrogen-to-protein conversion factors for animal and plant foods. *Journal of Agricultural and Food Chemistry* 38(6):1351-6.
- Thiansilakul Y, Benjakul S, Shahidi F. 2007. Antioxidative activity of protein hydrolysate from round scad muscle using alcalase and flavourzyme. *Journal of Food Biochemistry* 31(2):266-87.
- Turgeon SL, Gauthier SF, Paquin P. 1991. Interfacial and emulsifying properties of whey peptide fractions obtained with a two-step ultrafiltration process. *Journal of Agricultural and Food chemistry* 39(4):673-6.
- Valencia P, Pinto M, Almonacid S. 2014. Identification of the key mechanisms involved in the hydrolysis of fish protein by Alcalase. *Process Biochemistry* 49(2):258-64.
- Wald M, Schwarz K, Rehbein H, Bußmann B, Beermann C. 2016. Detection of antibacterial activity of an enzymatic hydrolysate generated by processing rainbow trout by-products with trout pepsin. *Food chemistry* 205:221-8.
- Walker P, Warner R, Winfield C. 1990. Sources of variation in subcutaneous fat colour of beef carcasses. *Proceedings of the Australian Society of Animal Production*. p. 416-9.
- Wang G, Mishra B, Lau K, Lushnikova T, Golla R, Wang X. 2015. Antimicrobial peptides in 2014. *Pharmaceuticals* 8(1):123-50.



- Wasswa J, Tang J, Gu X-h, Yuan X-q. 2007. Influence of the extent of enzymatic hydrolysis on the functional properties of protein hydrolysate from grass carp (*Ctenopharyngodon idella*) skin. *Food Chemistry* 104(4):1698-704.
- Wu H-C, Chen H-M, Shiau C-Y. 2003. Free amino acids and peptides as related to antioxidant properties in protein hydrolysates of mackerel (*Scomber austriasicus*). *Food research international* 36(9):949-57.
- Yamaguchi T, Takamura H, Matoba T, Terao J. 1998. HPLC method for evaluation of the free radical-scavenging activity of foods by using 1, 1-diphenyl-2-picrylhydrazyl. *Bioscience, biotechnology, and biochemistry* 62(6):1201-4.
- Yang H, Wang Y, Zhou P, Regenstein JM. 2008. Effects of alkaline and acid pretreatment on the physical properties and nanostructures of the gelatin from channel catfish skins. *Food Hydrocolloids* 22(8):1541-50.
- Yasumatsu K, Sawada K, Moritaka S, Misaki M, Toda J, Wada T, Ishii K. 1972. Whipping and emulsifying properties of soybean products. *Agricultural and Biological Chemistry* 36(5):719-27.
- Yeaman MR, Yount NY. 2003. Mechanisms of antimicrobial peptide action and resistance. *Pharmacological reviews* 55(1):27-55.
- Yin H, Pu J, Wan Y, Xiang B, Bechtel PJ, Sathivel S. 2010. Rheological and functional properties of catfish skin protein hydrolysates. *Journal of food science* 75(1):E11-E7.
- You L, Zhao M, Cui C, Zhao H, Yang B. 2009. Effect of degree of hydrolysis on the antioxidant activity of loach (*Misgurnus anguillicaudatus*) protein hydrolysates. *Innovative Food Science & Emerging Technologies* 10(2):235-40.

- Yu J, Ahmedna M, Goktepe I. 2007. Peanut protein concentrate: Production and functional properties as affected by processing. *Food Chemistry* 103(1):121-9.
- Zayas JF. 1997. Introduction. *Functionality of proteins in food*: Springer. p. 1-5.
- Zhang S, Wang Y, Herring J, Oh JH. 2007. Characterization of edible film fabricated with channel catfish (*Ictalurus punctatus*) gelatin extract using selected pretreatment methods. *Journal of Food Science* 72(9):C498-C503.

## **VITA**

Cesar Augusto Galindo Perez was born in October 1986 in Patulul, Suchitepequez, Guatemala. He obtained his Bachelor of Sciences in Food Science and Technology in Panamerican Agricultural School, Zamorano, Valley of Yeguaré, Honduras, in December 2008. After working in the guatemalan dairy industry for 5 years, he became a graduate student in the School of Nutrition and Food Sciences at LSU in August, 2014. He expects to graduate in December, 2016.