

12-2015

Economic Feasibility of Aquaponics in Arkansas

Leah Ashley English

University of Arkansas, Fayetteville

Follow this and additional works at: <http://scholarworks.uark.edu/etd>

 Part of the [Agricultural Economics Commons](#), [Food Security Commons](#), and the [Fresh Water Studies Commons](#)

Recommended Citation

English, Leah Ashley, "Economic Feasibility of Aquaponics in Arkansas" (2015). *Theses and Dissertations*. 1322.
<http://scholarworks.uark.edu/etd/1322>

This Thesis is brought to you for free and open access by ScholarWorks@UARK. It has been accepted for inclusion in Theses and Dissertations by an authorized administrator of ScholarWorks@UARK. For more information, please contact scholar@uark.edu, ccmiddle@uark.edu.

Economic Feasibility of Aquaponics in Arkansas

A thesis submitted in partial fulfillment
of the requirements for the degree of
Master of Science in Agricultural Economics

by

Leah English
University of Arkansas - Fort Smith
Bachelor of Science in Biology, 2009

December 2015
University of Arkansas

This thesis is approved for recommendation to the Graduate Council.

Dr. Eric Wailes
Thesis Director

Dr. Jeroen Buysse
Committee Member

Dr. Jennie Popp
Committee Member

ABSTRACT

Concerns regarding population growth and resource scarcity have led to a recent renaissance of food production research. Over the past few decades, scientists have discovered new and innovative methods for growing food that, cumulatively, may hold the key to efficiently and sustainably feeding an ever-increasing world population. One method, known as aquaponics, has shown promise as being a sustainable solution for producing food locally in all parts of the world. Although many studies have shown aquaponic food production to be technically feasible, there are relatively few studies concerning the economic feasibility of aquaponics in various regions. To determine whether aquaponics could be economically feasible under greenhouse conditions in temperate climates, cost and revenue data for constructing and operating the University of the Virgin Islands' Commercial Aquaponics 2 system were collected from various sources. These data were then used to develop enterprise budgets for the aquaponic production of tilapia, lettuce and basil. Additional financial analyses included the calculation of break-even prices for each crop, a cash-flow analysis of three farm scenarios and the determination of investment payback period. Overall, it appears that aquaponic food production using the UVI CA2 system could be economically feasible in temperate climates, assuming a proper selection of crops, in conjunction with the existence of viable markets. The results also show, however, that greater focus on hydroponic production may potentially yield higher profits than those attainable through a fully integrated aquaponic production system.

ACKNOWLEDGEMENTS

First and foremost, I would like to thank the faculty and staff of the Department of Agricultural Economics and Agribusiness of the University of Arkansas, as well as the faculty and staff of the Department of Agricultural Economics at Ghent University. The experience and knowledge gained through my master's studies at these two universities are truly invaluable.

I would also like to express my sincere gratitude to my advisor Dr. Eric Wailes for his patience, motivation and continuous support of my study. In addition, I would like to thank the rest of my thesis committee: Dr. Jennie Popp and Dr. Jeroen Buysse. I would especially like to thank Dr. Popp for providing me the opportunity to work with her as a graduate research assistant and for pushing me forward in my studies.

I also thank my fellow classmates, not only for their encouragement and motivation, but for the stimulating discussions, new world perspectives, and for all the fun times and memories we have shared while studying and traveling the world together.

Last but not least, I would like to thank my grandparents, Bobby and Virginia Ross. Without their lifelong support, I am certain that I would not have made it to where I am today. I am beyond thankful and forever grateful to have such wonderful people in my life.

TABLE OF CONTENTS

| | |
|--|----|
| CHAPTER 1 | 1 |
| INTRODUCTION | 1 |
| 1.1 PROBLEM STATEMENT AND STUDY JUSTIFICATION..... | 1 |
| 1.2 STUDY PROBLEM AND OBJECTIVES | 3 |
| CHAPTER 2 | 4 |
| BACKGROUND INFORMATION AND REVIEW OF LITERATURE | 4 |
| 2.1 HISTORY AND BACKGROUND | 4 |
| 2.1.1 Aquaculture..... | 4 |
| 2.1.2 Hydroponics | 5 |
| 2.1.3 Aquaponics – A Sustainable Closed-Loop System | 6 |
| 2.1.4 Nitrification and Beneficial Bacteria | 6 |
| 2.2 REVIEW OF LITERATURE | 7 |
| 2.2.1 Aquaponic Production Trials – U.S. Virgin Islands | 10 |
| 2.2.2 Aquaponic Production Trials – Alberta, Canada | 15 |
| 2.2.3 Economic Analysis | 17 |
| 2.2.4 Market Analysis | 19 |
| 2.2.5 Food Safety in Aquaponics | 21 |
| CHAPTER 3 | 23 |
| METHODS | 23 |
| 3.1 COST ANALYSIS..... | 23 |
| 3.1.1 Determination of Fixed Costs | 24 |
| 3.1.2 Determination of Variable Costs | 37 |
| 3.2 REVENUE ANALYSIS | 45 |
| 3.2.1 Determining Annual Production | 45 |
| 3.2.2 Determining Local Market Price | 46 |
| 3.3 FINANCIAL BUDGET ANALYSIS | 47 |
| 3.3.1 Development of Enterprise Budgets | 47 |
| 3.3.2 Break-Even Analysis | 48 |
| 3.3.3 Examination of Cash Flows and Payback Period | 48 |
| 3.3.4 Sensitivity Analysis | 48 |
| CHAPTER 4 | 50 |
| RESULTS | 50 |

| | | |
|-------|-------------------------------------|----|
| 4.1 | COST ANALYSIS..... | 50 |
| 4.1.1 | Fixed Cost..... | 50 |
| 4.1.2 | Variable Cost | 51 |
| 4.2 | REVENUE ANALYSIS | 52 |
| 4.3 | FINANCIAL BUDGET ANALYSIS | 52 |
| 4.3.1 | Enterprise Budgets | 52 |
| 4.3.2 | Break-Even Analysis | 58 |
| 4.3.3 | Cash Flows and Payback Period..... | 59 |
| 4.3.4 | Sensitivity Analysis | 61 |
| | CHAPTER 5 | 64 |
| | SUMMARY AND CONCLUSIONS | 64 |
| 5.1 | THESIS SUMMARY | 64 |
| 5.2 | OTHER CONSIDERATIONS..... | 65 |
| 5.3 | OVERALL CONCLUSIONS..... | 68 |
| 5.4 | FUTURE RESEARCH OPPORTUNITIES | 69 |
| | REFERENCES | 70 |
| | APPENDIX..... | 75 |

ABBREVIATIONS

BAF – Brooks Aquaponics Facility

BTU – British Thermal Unit

CA1 – Commercial Aquaponics 1

CA2 – Commercial Aquaponics 2

CAO – Calcium Oxide

Ca(OH)₂ – Calcium Hydroxide

DLI – Daily Light Integral

DO – Dissolved Oxygen

DWC – Deep Water Culture

HAF – Horizontal Airflow Fan

KOH – Potassium Hydroxide

LDPE – Low Density Polyethylene

NFT – Nutrient Film Technique

PAR – Photosynthetically Active Radiation

RAS – Recirculating Aquaculture System

UVI – University of the Virgin Islands

DEFINITIONS

Aquaculture – the farming of aquatic organisms, including fish, mollusks, crustaceans and aquatic plants

Aquaculture Component – the portion of the aquaponic system involved in fish production

Aquaponics – the production of food using a combination of aquaculture and hydroponics

Aquaponic System – a complete aquaponic system consisting of four fish rearing tanks and six hydroponic tanks

Backyard Aquaponics – aquaponic production on a small-scale, generally for home consumption

British Thermal Unit (BTU) – the amount of energy necessary to raise one pound of water by one degree Fahrenheit

Commercial Aquaponics – aquaponic production on a scale large enough to allow the sale of food products to the public

Daily Light Integral (DLI) – measurement of the amount of photosynthetically active radiation (PAR) received each day as a function of light intensity and duration. Measured in $\text{mol m}^{-2} \text{d}^{-1}$.

Environmental Control System – components used to control environmental aspects such as air temperature, water temperature, air circulation and light intensity

Hydroponic Component – the portion of the aquaponic system involved in plant production

Hydroponics – the culture of plants without the use of soil

Heat Loss Value – measure of heat transmission of a material when exposed to air on both sides

Nitrification – a biological process involving the conversion of ammonia to nitrite and nitrate

Photosynthetically Active Radiation (PAR) – the wavelength range (400-700 nm) that photosynthetic organisms are able to use during the process of photosynthesis

LIST OF FIGURES

| | |
|--|----|
| Figure 1: Examples of backyard aquaponic systems | 8 |
| Figure 2: UVI CA2 aquaponic system..... | 9 |
| Figure 3: Diagram of UVI CA2 system..... | 13 |
| Figure 4: Diagram of BAF aquaponic system | 16 |
| Figure 5: Maps of monthly outdoor DLI throughout the United States | 33 |

LIST OF TABLES

| | |
|--|----|
| Table 1: Capital cost of aquaponic system | 25 |
| Table 2: Annual energy cost of greenhouse heating..... | 31 |
| Table 3: Daily light necessary to achieve optimal DLI for leafy crops | 34 |
| Table 4: Daily light necessary to achieve optimal DLI for flowering crops | 35 |
| Table 5: Capital cost of environmental control..... | 37 |
| Table 6: Annual fingerling and seedling cost | 38 |
| Table 7: Annual other input cost..... | 40 |
| Table 8: Annual labor cost..... | 41 |
| Table 9: Annual system utility cost | 42 |
| Table 10: Annual environmental control utility cost | 45 |
| Table 11: Arkansas Asian market tilapia prices | 47 |
| Table 12: Share of variable costs for each crop..... | 49 |
| Table 13: Capital cost of aquaponic system (including environmental control) | 51 |
| Table 14: Annual revenues from CA2 aquaponic production | 52 |
| Table 15: Enterprise budget for production of tilapia..... | 53 |
| Table 16: Enterprise budget for production of lettuce | 54 |
| Table 17: Enterprise budget for production of basil | 55 |
| Table 18: Farm Scenario 1 - Tilapia and Lettuce | 56 |
| Table 19: Farm Scenario 2 - Tilapia and Basil | 57 |
| Table 20: Farm Scenario 3 - Tilapia, Lettuce and Basil | 58 |
| Table 21: Break-even price for aquaponic crops | 58 |
| Table 22: Profit margin on sales for aquaponic crops | 59 |

| | |
|--|----|
| Table 23: Projected cash flows for farm scenario 1 – tilapia and lettuce | 59 |
| Table 24: Projected cash flows for farm scenario 2 – tilapia and basil | 60 |
| Table 25: Projected cash flows for farm scenario 3 – tilapia, lettuce and basil..... | 60 |
| Table 26: Payback period..... | 61 |
| Table 27: Tilapia net revenues with varying market price and fingerling cost | 61 |
| Table 28: Tilapia revenues with varying market price and feed cost | 62 |
| Table 29: Break-even price with varying fingerling and feed cost..... | 62 |
| Table 30: Lettuce net revenues with varying market price and seedling cost | 62 |
| Table 31: Basil new revenues with varying market price and seedling cost | 63 |
| Table 32: Percentage of total basil harvest sold..... | 66 |
| Table 33: Percentage of total lettuce harvest sold | 66 |

LIST OF APPENDICES

| | |
|--|----|
| Appendix 1: Capital cost of aquaculture component..... | 75 |
| Appendix 2: Capital cost of hydroponic component | 78 |
| Appendix 3: Monthly energy costs for Arkansas: | 81 |
| Appendix 4: Calculation of DLI change in double-polyethylene greenhouse..... | 82 |
| Appendix 5: Greenhouse BTU calculation | 83 |
| Appendix 6: Heating cost calculation | 84 |
| Appendix 7: Monthly utility cost for environmental control..... | 85 |

CHAPTER 1

INTRODUCTION

1.1 PROBLEM STATEMENT AND STUDY JUSTIFICATION

In recent decades, overfishing has led scientists to experiment with new methods of aquaculture in order to increase production and prevent further depletion of natural aquatic stock. Although fish farming has been around for centuries, recent advances in science and research have allowed farmers to dramatically increase fish production. These new methods, while achieving the goal of increasing production, have shown considerable constraints. The largest of these constraints being the proportional increase in the generation of solid fecal waste and ammonia that occurs as aquaculture production becomes more intensive. The accumulation of additional waste ultimately results in an increase in fish mortality and a decrease of overall fish growth and health within the system. A method of fish production known as recirculating aquaculture strives to counteract this constraint by circulating water through clarifiers and filters which remove waste from the system and breakdown nitrogen compounds which, at certain levels, are toxic to the fish.

In addition to problems experienced with aquatic farming, factors such as land availability, soil erosion, drought and pollution have generated the need for scientists to also re-examine the world's terrestrial food production techniques. There is presently a great push to increase productivity while at the same time conserving space and resources. Although the "Green Revolution" resulted in unprecedented advances in agricultural production, it is believed that a second agricultural revolution will be necessary in order to meet the expected future demand for

food. Soilless plant production, generally referred to as hydroponics, offers a solution to this problem by allowing plants to be grown almost anywhere while also utilizing minimal resources.

Recirculating aquaculture and hydroponics individually offer solutions for increasing intensive production and environmental sustainability. However these systems each carry their own drawbacks which limit the overall efficiency and profitability of their operation. In the case of recirculating aquaculture, water quality must be monitored consistently and discharge of waste water must regularly occur in order to maintain optimal water quality levels (Losordo, 1998). Similarly, within hydroponic production, the uptake of nutrients by plants, as well as chemical changes that occur within the hydroponic solution, result in the occasional removal of water from the system which must then be replaced by fresh nutrient solution. Although less environmentally harmful than nutrient leaching from traditional agriculture, the disposal of nutrient water discharged from these systems does present certain challenges for producers, as well as an overall loss of water conservation efficiency for the system (Christie, 2014)

Other challenges inhibiting the growth of these industries involve respectively high capital costs, moderate energy inputs and the high level of skill required to manage these systems (Rakocy, 2000). Many problems inherent to both recirculating aquaculture and hydroponics may be solved by combining the two methods into one, closed-loop system known as aquaponics. The ultimate result of this combination is a sustainable food production method that mimics natural ecosystems, while efficiently utilizing resources and reducing pollution.

Although aquaponics stands to offer numerous benefits, the question of the economic feasibility for this endeavor is debatable. Finding the answer lies in determining whether the proposed increase in production, efficiency and sustainability of aquaponics outweighs its

comparatively high capital and operational costs. Research conducted in the U.S. Virgin Islands and Hawaii has shown promising results regarding the economic feasibility of aquaponics in tropical climates. However, there is currently little information pertaining to the economic assessment of aquaponics in temperate climates such as those found throughout most of the United States.

1.2 STUDY PROBLEM AND OBJECTIVES

Due to a lack of available information regarding the economic feasibility of aquaponics outside of tropical climates, this study attempts to fill in this knowledge gap by examining the economic feasibility of the construction and operation of an aquaponics farm within the temperate climate found in the U.S. state of Arkansas. Producing aquaponically grown food in such a climate will theoretically result in increased costs when compared to aquaponic food production in tropical regions. These additional costs are incurred as environmental control mechanisms such as greenhouses, supplementary lighting, heaters and coolers must be utilized in order to achieve optimal production. The objective of this study is to determine whether these additional costs can be offset, resulting in an economically feasible and environmentally sustainable food production system for year-round use in temperate climates.

CHAPTER 2

BACKGROUND INFORMATION AND REVIEW OF LITERATURE

2.1 HISTORY AND BACKGROUND

Aquaponics, in its simplest form, has been practiced for hundreds of years. From the chinampa farming methods of the ancient Aztecs to present day floating gardens found in Myanmar and Bangladesh, farmers realize the advantage of utilizing nutrient-rich water from ponds and lakes to enhance production of their crops. Modern farmers and researchers hope to expand on this knowledge with an ultimate goal of increasing the production and local availability of animal protein and vegetables, while also conserving water, limiting land use and drastically reducing farm-based pollution and waste.

Because aquaponics involves the combination of two separate farming systems, it is important to first examine these systems individually in order to gain a complete understanding of aquaponics as a whole. The following sections, provide an overview of each individual component, in addition to examining the entire closed-loop system.

2.1.1 Aquaculture

The FAO defines aquaculture as “the farming of aquatic organisms, including fish, mollusks, crustaceans and aquatic plants.” Aquaculture has been adapted in many regions as an effective means of supplying animal protein to local peoples, while at the same time attempting to reduce the effects of overfishing caused by wild capture fisheries. While aquaculture has historically utilized pond culture, open water culture or flow-through raceways to intensively produce fish, these methods are often hindered by the build-up of waste produced by the farmed organisms. This waste build-up has been found to ultimately limit production, as seen in pond

culture, or cause environmental damage, as seen with open water and flow-through systems. In recent years, the use of recirculating aquaculture systems (RAS) has become increasingly popular. In these systems, water from fish tanks is cleaned by circulation through a system of filters before returning to the tanks. While this method requires higher investment, energy and management costs, it can considerably increase aquaculture activity per unit of land and is currently the most efficient, water-saving technology being employed in fish farming (Somerville, 2014).

2.1.2 Hydroponics

Although agriculture is traditionally linked to the soil, scientists in the early 20th century discovered that, while plants use the soil to obtain water, nutrients and support, soil itself is not necessary for successful plant growth. From this research came a new farming method known as hydroponics. Hydroponics can be defined as: the raising of plants without soil. This may involve growing plants in containers filled with different non-soil media such as gravel, sand, perlite, vermiculite, hydro ton, or coconut coir. Other methods of hydroponic production do not require any additional media as the plants are supplied a nutrient solution directly to their roots. Some examples of this include: nutrient film technique (NFT), deep water culture (DWC) and aeroponics.

By replacing soil with either a non-soil medium or using direct nutrient application, farmers are able to eliminate all soil-borne pests, diseases and weeds. In addition, farmers are able to maintain exact control of nutrients and easily make adjustments to promote optimal plant growth and ensure more uniform results (Nicholls, 1990). By separating farming from the soil, farmers are also allowed to more efficiently utilize space through use of methods such as vertical farming, or grow plants in areas where arable land is unavailable such as desert regions and

urban centers. Additionally, hydroponic farming generally results in greater water efficiency and less waste than traditional farming methods as most methods involve the capture and reuse of nutrient solutions.

2.1.3 Aquaponics – A Sustainable Closed-Loop System

Aquaponics, as the name infers, is the combination of aquaculture and hydroponic components into one, closed-loop system. This combination results in the waste from one system being used as an input for the other as plants, with the help of beneficial bacteria, work to filter the water for the fish, while fish provide a steady supply of nutrients for the plants. This also allows for the intensive production of both animal protein and plants simultaneously, as well as resulting in as much as 90% less water use than traditional farming methods. As long as a proper balance of fish and plant production is maintained, there is no need to purge the system, resulting in a large increase in water efficiency when compared to stand-alone systems.

2.1.4 Nitrification and Beneficial Bacteria

Although aquaponics combines two main components, aquaculture and hydroponics; a third component is also necessary to ensure proper functioning of the system. This is the bacterial component which functions to convert waste from aquaculture into nutrients more readily available for uptake by the plants. This process of waste conversion is known as nitrification.

Through the process of nitrification, ammonia, which is produced by, and toxic to the fish, is broken down by *Nitrosomas sp.* bacteria into nitrite. Nitrite, which is also toxic to fish, is then broken down by a second bacteria, *Nitrobacter sp.*, into nitrate. Nitrate is much less toxic to

fish and happens to be the form of nitrogen that plants utilize. It is because of this nitrogen breakdown that bacteria and nitrification are crucial for successful aquaponic production.

2.2 REVIEW OF LITERATURE

Aquaponics, as it is commonly known today, stems from research in the fields of recirculating aquaculture and hydroponics. The most notable of such research has been conducted by members of the aquaculture program at the University of the Virgin Islands (UVI). UVI's aquaculture program began in 1979 with initial efforts focusing on the cage culture of tilapia in watershed ponds. Dr. James Rakocy quickly expanded the aquaculture program to include aquaponic research, resulting in the construction of several aquaponic demonstration systems that have been in operation for well over a decade. Each year, researchers and producers travel from around the world to tour UVI's aquaponic facility and participate in workshops where they are able to learn hands-on about the process of aquaponics (UVI, 2015).

Since its inception, aquaponic food production methods have been utilized in numerous ways and the technology has quickly spread to all parts of the world. The types of systems range from small backyard models for hobbyists, to large commercial-scale systems. Simple backyard models can be made from inexpensive or recycled materials such as international bulk containers (IBC totes) or plastic barrels as seen in the "Barrel-ponics" method developed by Travis W. Hughey (Hughey, 2005). Backyard aquaponic guides and kits may also be purchased through companies and websites such as Portable Farms[®], The Aquaponic Source[™], Practical Aquaponics, or Nelson and Pade, Inc. As there are literally hundreds of ways that aquaculture and hydroponics may be combined to produce almost any combination of ornamental or food crop, the design and construction of these systems vary depending on the expense and amount of time each individual is willing to invest in their hobby (Fig. 1).

Figure 1: Examples of backyard aquaponic systems



Source: Travis W. Hughey



Source: Practical Aquaponics

At present, aquaponics is primarily being practiced by hobbyists wishing to sustainably produce chemical-free food in their backyard. However, interest in commercial aquaponics has experienced a significant increase over the past decade. Throughout different aquaponic channels, there has been some debate as to the scale at which aquaponics is ultimately considered “commercial”. For the purposes of this paper, aquaponics is considered commercial if food is being produced for sale to the public; whether this be through direct market mechanisms such as farm-gate sales or farmer’s markets, to restaurants, or through retail stores. As with small-scale, backyard aquaponics, commercial systems may be built using relatively inexpensive materials as described in the publication *How to Build and Operate a Simple Small-to-Large Scale Aquaponics System* by Dr. Harry Ako of the College of Tropical Agriculture and Human Resources (Ako, 2014). Commercial kits may also be purchased from companies such as Nelson and Pade, Inc., Pentair, Ltd., Farm Tek or numerous other suppliers.

While commercial aquaponics appears to offer a sustainable alternative to current aquaculture and vegetable production methods, the process does require significant expertise in

fish and vegetable production, as well as vast knowledge of additional scientific principles involved throughout the process. And as relatively little research has been published regarding the operation and production potential for aquaponics, the profit potential for these various system designs has yet to be confirmed.

Although there is little data available concerning the costs and production potential over the multitude of commercial aquaponic system designs which are currently being utilized by individual farmers and researchers, the decades of research conducted by the University of the Virgin Islands aquaculture program has made Dr. Rakocy and the UVI team leading experts in the field. As they have successfully operated and collected data from their Commercial Aquaponics 2 (CA2) system for several years, it is currently the primary design used for commercial aquaponic research. It is because of this that the UVI CA2 system design was selected as the model for this analysis (Fig.2).

Figure 2: UVI CA2 aquaponic system



Source: UVI Aquaculture Program

The following sections detail the current literature regarding research involving aquaponic production using the UVI system design.

2.2.1 Aquaponic Production Trials – U.S. Virgin Islands

Realizing the need for increased fish and plant production throughout the Caribbean, researchers from UVI worked to develop an outdoor commercial aquaponic system, later named commercial aquaponics 1 (CA1), which was initially tested over a two and a half year period from January 26, 1995 through June 30, 1997. This trial system consisted of four fish rearing tanks (4.4 m³ each), two cylindro-conical clarifiers (1.8 m³ each) for solid waste removal, four filter tanks (0.7 m³ each) for trapping fine solids, six hydroponic tanks (29.6m x 1.2m x 0.4m each) for plant production using deep water culture, and a sump (0.6 m³) to collect water and return it back to the rearing tanks. Water and air pumps were used to obtain proper water circulation and aeration throughout the system (Rakocy, 2000).

In the aquaculture component of the system, researchers examined the production of red tilapia. By utilizing a staggered production method, researchers were able to harvest one of the four fish tanks every six weeks. The results showed an average harvest weight of 487 g/fish with annual production measured at 3,096 kg. The feed conversion ratio ranged between 1.75 and 1.77 and the average mortality rate was 8.4% with highest mortality occurring at water temperatures above 28°C (82.4°F). During the study, flow rate was increased from 163 L/min to 378 L/min. This change had no measurable effect on fish production however accumulation of solids within the filter tanks increased causing an associated decrease in nitrate-nitrogen levels. To overcome this problem, cleaning of the filter tanks was increased from once a week to twice a week.

In the hydroponic component of the system, five varieties of lettuce were cultured using staggered production; red leaf (Sierra), green leaf (Nevada), romaine (Parris Island and Jericho) and crisphead (Montello). One fourth of lettuce was harvested each week and immediately replaced with three week old transplants. The total annual lettuce production averaged 1,248 cases containing 24-30 heads/case. Lettuce production was greatest at an average water temperature of 25.1°C. There were no observable nutrient deficiencies however zooplankton blooms, pathogenic root fungi (*Pythium myriotylum*), caterpillars and aphids caused plant damage and decreased production. Zooplankton blooms were controlled by the introduction of ornamental fish, the most effective of which being tetras. It was determined that *Pythium* could be controlled by lowering water temperatures while caterpillars and aphids were controlled by bi-weekly sprays with *Bacillus thuringiensis*.

Water quality was maintained by the adjustment of flow rate and cleaning frequency of the filter tanks. Because nitrification is an acid producing process, pH and alkalinity showed constant decline. The bases potassium hydroxide (KOH), calcium oxide (CaO) and calcium hydroxide (Ca(OH)₂) were found to be most effective at counteracting this effect. During the trial 168.48 kg of KOH, 34.48 kg of CaO, 142.9 kg of Ca(OH)₂ were added to the system. The use of CaO was discontinued during the trial due to higher costs associated with its use. Additionally, 62.668 kg of iron chelate (13% Fe) was added to the system in order to prevent iron deficiency during plant growth. Later studies found the approximate annual addition of these chemicals to be 38.85 kg of KOH, 40.65 kg of Ca(OH)₂ and 32.83 kg of iron chelate (Rakocy, 2004b).

The optimum daily feed to plant growing area ratio for lettuce production was determined to be 57 grams of feed per m² of hydroponic growing area (Rakocy, 1997). As a result, average

daily feed input for the trial averaged 12.0 kg and was equivalent to 56 g/m² of plant growing area per day.

Water consumption during the trial was relatively low when compared to traditional recirculating aquaculture systems. With an average water use of 0.25 m³/kg of total tilapia production and 2.1 cases (50 heads) of lettuce produced per cubic meter of water, the UVI system ranked very high in terms of water use efficiency (Cole *et al.*, 1997; Losordo, 1997).

Based on the results of this trial, researchers concluded that several modifications should be made to the system in order to increase fish and lettuce production and ease system management. These modifications included increasing the size of the fish rearing tanks to 7.8 m³, enlarging the clarifiers to 3.8 m³, adding a base addition tank near the sump, and adding a 0.7 m³ rectangular degassing tank to discharge gasses generated by biological processing within the filter tanks. After struggling with automatic feeders, it was determined that manual feeding twice a day would be the most appropriate feeding method for future studies. Because of problems experienced during lettuce production that were caused by high temperatures, several design changes were planned in order to maintain water temperature below 26.7°C. Following these system modifications, additional trials were performed utilizing a new system design that researchers called Commercial Aquaponics 2 (CA2) (Fig. 3). These trials were conducted during the periods January 28 –May 20 and June 18-September 20, 2002 and analyzed the production of tilapia and basil.

Figure 3: Diagram of UVI CA2 system

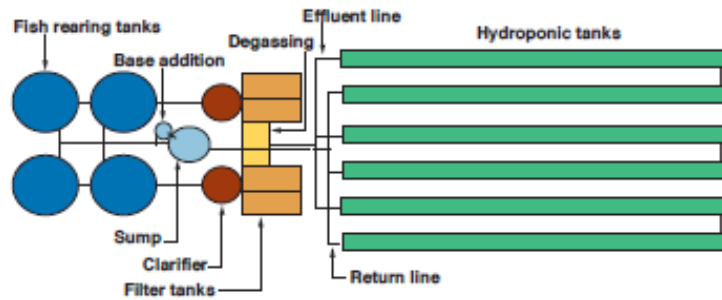

Source: Southern Regional Aquaculture Center Publication No. 454

The study also compared different cropping methods to determine the most efficient mechanism for aquaponic plant production. The two cropping methods analyzed were batch and staggered cropping. With batch cropping, the entire system is planted at once and is also harvested at one time. In staggered cropping, planting and harvesting are staggered so that only a portion of the system is being planted/harvested at one time. By altering the cropping methods, researchers were able to evaluate production ratios to determine adequate fish feeding values in comparison to plant growing area and production levels. Aquaponic basil production was also compared to field crop production during these trials (Rakocy, 2004a).

Results of the trials showed that batch and staggered production were comparable in terms of the amount of basil produced. At yields of 5,341 kg per year for batch production and 5,008 kg per year for staggered production, both methods showed production levels that were three times higher than equivalent field production. Although batch production resulted in slightly higher yields, this method was not sustainable due to nutrient deficiencies which rendered much of the harvest unmarketable. With staggered production, the higher nutrient requirement for plants in their final growth stages was offset by the lower nutrient requirement

for plants in their initial growth stages which moderated nutrient depletion throughout the system. Based on these results, researchers recommend that a staggered production technique be used for plant production in aquaponic systems.

For the fish production component, researchers employed a staggered production technique and a 24 week grow out period. By this method, an average harvest of 480 kg/tank for Nile tilapia and 551 kg/tank for red tilapia was obtained, with harvests occurring every 6 weeks. From this data, annual production was calculated at 4.16 metric tons (9,152 lbs.) for Nile tilapia and 4.78 metric tons (10,516 lbs.) for red tilapia. However researchers anticipate that production may be increased to 5 metric tons (11,000 lbs.) by closely monitoring the *ad libitum* feeding response while dispensing feed.

The following year during the period of October 1- December 22, 2003, an okra production trial was conducted using the same system design and setup as the basil trials. Three varieties were evaluated: North-South, Annie Oakley and Clemson Spineless. They were each transplanted into the aquaponic system at two densities – 2.7 plants/m² (low density) and 4.0 plants/m² (high density). Okra was also planted in a nearby field to provide researchers with a comparison of production methods. During the trial, the highest production was attained by the North-South variety planted at the highest density with a production value of 3.04 kg/m². Production of field okra was significantly lower with a total production value of 0.15 kg/m² and also required a higher labor investment than its aquaponic counterpart. After conducting an economic analysis, it was determined that, although okra grows rapidly in a raft aquaponic system and does well under warm conditions, it is not nearly as lucrative a crop as culinary herbs such as basil. Researchers concluded however that, while okra isn't as lucrative as culinary herbs, it may be utilized as a warm weather crop in rotation with cool weather crops such as

lettuce and may be useful for farmers attempting to produce a larger variety of vegetables for local restaurant markets (Rakocy, 2004b).

2.2.2 Aquaponic Production Trials – Alberta, Canada

The seasonally warm weather of tropical regions allows farmers to produce aquaponic crops outdoors, year-round and without the added expense of fuel and machinery for heating. While aquaponics has shown promise toward becoming a feasible farming method for tropical climates, questions still remain regarding the potential for aquaponic operation within cooler climates. To answer these questions, researchers at the Brooks Aquaponics Facility (BAF) in Alberta, Canada built an aquaponics system based on the University of the Virgin Islands design to be used as a prototype for commercialization of aquaponics in Alberta (Savidov, 2004). The goal of this project was to assess the potential of aquaponic crops grown commercially under Canadian greenhouse conditions.

The Brooks Aquaponics Facility (BAF) consisted of three greenhouses with one greenhouse containing aquaculture equipment and the other two containing plant growing troughs. The aquaculture component mimicked the UVI CA2 model and contained four fish rearing tanks, two conical clarifiers, four settling (filter) tanks, a degassing tank, central sump, base mixing barrel, and four plant growing troughs (Fig. 4).

Figure 4: Diagram of BAF aquaponic system

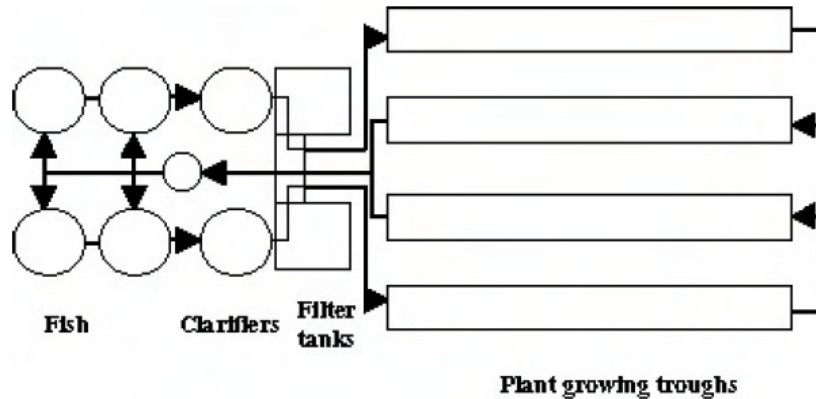

Source: Savidov, 2004

The greenhouse and recirculation system were maintained under full-computerized control using environmental parameters such as air temperature, humidity and irradiation. Water quality measurements such as water temperature, oxygen levels, electric conductivity (EC), and pH were also continuously monitored. To maintain a constant water temperature of 24.5°C (76.1°F), fresh water was plumbed into the sump tank through a heat exchanger and boiler system. pH was carefully monitored and was maintained near 6.2 by the addition of $\text{Ca}(\text{OH})_2$ or KHCO_3 to increase pH, or H_3PO_4 to reduce pH levels. Air temperature was maintained between 22-25°C with irradiation levels kept at 300 μmol photons per m^2sec and a 16:8 day to night photoperiod provided by both natural and artificial light.

Similar to the UVI trials, tilapia were grown by means of staggered production within a 24-week growth cycle. Tilapia were raised to market size (700g) with one tank being harvested every 6 weeks.

Several plant varieties were analyzed during the trial. The plants were grouped according to their commercial importance and conductivity factors. Production was staggered so that plant production was roughly balanced with fish production. Tomatoes and mini cucumbers achieved annual yields of 20.7 kg and 33.4 kg per plant, respectively, which exceeded average values obtained through conventional hydroponic production in Alberta. Basil and other culinary herbs also exhibited high yields and market potential in Alberta.

2.2.3 Economic Analysis

In 1997, Bailey, Rakocy, Cole and Schultz performed an economic analysis of an early version of the UVI commercial aquaponics system. This analysis examined the costs and benefits of a commercial aquaponics operation consisting of 6, 12, and 24 individual aquaponic systems. Each system consisted of 4 fish rearing tanks and 2 hydroponic tanks. For the analysis, pro forma enterprise budgets were used to itemize individual costs in order to examine their impact on total production cost. A break-even analysis was conducted in order to determine appropriate sales volume and price for each product to recover costs. A cash flow budget was developed with net present value and internal rate of return also being calculated. In addition to examining the costs associated with the aquaponics system itself, the analysis also took into account the costs of additional infrastructure components that may be required for production. These consisted of water collection tanks, feed and cold storage facilities, office and work room areas, trucks, tractors and wagons, greenhouse nurseries, brood fish holding and breeding tanks, and a fish hatchery.

The capital cost for each system in 1997 was approximately \$22,642 with fish and lettuce components costing \$13,780 and \$8,863, respectively. Farms with 6, 12, or 24 individual systems are expected to have capital costs of \$135,852, \$271,704 or \$543,408, respectively with

additional capital expenses of \$149,282, \$268,564, or \$487,128 for the additional infrastructure components listed in the previous paragraph.

In addition to calculating operating costs for the system as a whole, these costs were also determined for the system's individual aquaculture and hydroponic components. Total variable costs for the fish and lettuce components amounted to \$23,016 and \$19,720 respectively. Farms with 6, 12, or 24 aquaponic systems were expected to incur total variable costs of \$256,417, \$442,835, or \$870,670, respectively. Variable costs associated with fish production included the price of fingerlings, feed, pH balancing chemicals, electricity and labor. Costs associated with lettuce production came from the purchase of seedlings, packing boxes, chemical fertilizer and labor.

Budget analysis predicted returns from tilapia production to be -\$52,255, -\$62,010 and -\$109,019, respectively for the 6, 12 and 24 unit systems. Variables contributing most to operating costs were fingerlings and fish feed. Lettuce production appeared more favorable with positive returns of \$83,015, \$193,529 and \$387,057 being realized for the 6, 12 and 24 system farms. The most significant variable costs for lettuce production were hired labor, seedling transplants and packing boxes. Although fish production attributed negative returns for each farm size, returns gained from the lettuce component appeared to be sufficient to cover the costs associated with fish production.

The results of the UVI commercial aquaponics system trial suggest that there is potential for the use of aquaponics to provide a sustainable food source for island economies such as those found in the Caribbean. The study also suggests, however, that the feasibility of a commercial

aquaponics operation would rely on careful market analysis and considerations regarding economies of scale.

In the paper, *Evaluation and Development of Aquaponics Production and Product Market Capabilities in Alberta - Phase II*, researchers from the BAF in Alberta remarked on the profit potential of aquaponic food production in Canada (Savidov, 2005). Between 2003 and 2006 data for the production of Genovese basil in the BAF aquaponics system were collected for three trial periods: 2003/2004, 2004/2005 and 2005/2006. Researchers noted that between each trial period, basil production appeared to increase by approximately thirty percent. As a result, overall gross income increased from \$133.8 per m² of greenhouse space in 2003/2004 to \$184.0 per m² of greenhouse space in 2004/2005 and to \$236.2 per m² of greenhouse space in 2005/2006. Although the cause of the increase in production could not be determined, these results indicate that aquaponic basil growers may expect gross income to almost double over a period of two years without supplying any additional investments.

2.2.4 Market Analysis

In addition to analyzing the production potential and technical feasibility of greenhouse aquaponics at the Brooks Aquaponics Facility in Alberta, studies were also conducted to examine potential markets for aquaponic products within the region. One such study examined the feasibility of farm direct marketing of aquaponic products throughout Alberta Approved Farmer's Markets. To carry out the study, four small and four medium sized markets were chosen. A display was designed to inform visitors about the research project, including details about the process of aquaponic food production and describing the benefits of aquaponic vegetables. Photos and product samples were also supplied for the shoppers to test and provide feedback. The samples consisted of Long English cucumbers, Mini English cucumbers,

Gherkins, Chloe tomatoes, New York tomatoes, Grape tomatoes, and Pear tomatoes. After sampling, visitors were asked to complete a survey and/or discuss their views about aquaponic food production and share their opinions regarding the taste and quality of the samples.

Results of the study showed a very positive response to the vegetable samples with an overwhelming majority of visitors rating the taste and quality as either Excellent or Very Good. Small markets in rural areas were found to be the least desirable market for establishing a new product and consumer base. This is due to several factors which include smaller consumer bases, pre-existing relationships formed between consumers and well-established vendors, a large elderly consumer base living on fixed incomes and the fact that most consumers from rural areas already grow some of their own produce and therefore were less willing to pay a premium for aquaponically grown vegetables. Large markets near urban centers were found to be the most desirable markets for the introduction of a new product as these consumers were more willing to pay a higher premium for “chemical-free” products. However, many were concerned about the safety of consuming vegetables grown using fish effluent and the environmental impacts of farmed fish.

In another study, a telephone survey of 661 households and businesses in Southern Alberta was conducted to determine consumer perception of naturally grown products and the willingness to pay for these products (Thai et al. 2004). The results of this study showed that 76% of consumers felt that it was either very important or fairly important to obtain locally grown produce such as tomatoes or cucumbers, 66% felt that it was either very important or fairly important to obtain products that are grown without the use of chemical fertilizers, and 73% felt that it was either very important or fairly important to obtain a pesticide free product. Regarding willingness to pay, the majority of responded that they were willing to pay a premium

of \$3.00 per pound for tomatoes that were grown locally, pesticide free and using environmentally sustainable technology. From this the conclusion was made that consumers in Southern Alberta are likely willing to pay an average premium of 37% for aquaponically grown produce.

A review of the market for tilapia in Alberta showed an overall market saturation of the fish with little prospect of further growth (Warren, 2004). The main consumers were found to be of oriental background. This was the case in both the live fresh market and the food service restaurant market. As frozen tilapia can be imported from Thailand or Vietnam for \$0.99/lb., the frozen wholesale and retail market was dominated by imported fish.

Overall, researchers concluded that the market for aquaponics appears to be favorable; however, attention to market type, size and location; as well as crop selection, will be crucial in order to support a successful aquaponics operation.

2.2.5 Food Safety in Aquaponics

Due to concerns regarding the safety of consuming vegetables produced by aquaponic methods, Alberta researcher Gordon Chalmers, DVM conducted a review of the food safety of aquaponics (Chalmers, 2004). From the results of his review, it was concluded that food-borne and zoonotic disease associated with aquacultural products, including those obtained through aquaponic production methods, appeared to be rare. Moreover, there appeared to be less likelihood of contamination by pathogenic bacteria, especially in indoor systems when compared to traditional field methods of growing crops. Additional studies performed by Robison and Byrne found that unwashed produce grown aquaponically at Lethbridge Community College

exhibited bacterial counts that were within acceptable limits for ready-to-eat foods (Robison, 2003).

CHAPTER 3

METHODS

To determine the economic feasibility of aquaponics in Arkansas, the operation of an aquaponic system based on the UVI CA2 model was analyzed. Due to the availability of data concerning the production of crops within the CA2 aquaponic system; tilapia, lettuce and basil were the crops selected for analysis.

The analysis was based on methods put forth by Bailey *et al.* in their 1997 paper *Economic Analysis of a Commercial-Scale Aquaponic System for the Production of Tilapia and Lettuce*. As discussed in the following sections, cost and revenue analyses were used to develop enterprise budgets for the individual production of tilapia, lettuce and basil, with break-even prices calculated for each crop. Additional enterprise budgets were created for three farm scenarios exhibiting varying combinations of those crops. Cash flow budgets were developed for the three farm scenarios with payback periods calculated for each initial capital investment.

3.1 COST ANALYSIS

A cost analysis was performed in order to determine overall costs associated with the individual aquaculture and hydroponic components. These values were combined to give the cost of the CA2 aquaponics system as a whole. Additional costs pertaining to environmental control were calculated individually and added to the total cost of their respective component. Both fixed and variable costs were calculated and are later combined in section 3.3 to determine the total annual cost for the construction and operation of a UVI CA2 aquaponic system in Arkansas.

3.1.1 Determination of Fixed Costs

Fixed cost values used in the enterprise budgets were determined by calculating annual depreciation for each capital expense using a straight line method with no salvage value. These costs were calculated individually for the aquaponic system and environmental control systems and further separated by their association with either aquaculture or hydroponic components.

3.1.1.1 Aquaponic System

Prices for each capital item involved in the construction of the aquaponic system were obtained by contacting members of the aquaponics team at UVI. The price sheet provided by UVI was formulated in 2009, therefore the prices had to be adjusted to 2015 dollars using an inflation rate of 10.3 percent. This inflation rate was obtained through the U.S. Bureau of Labor Statistics' Consumer Price Index calculator (BLS, 2015). The cost of labor for construction of the system was obtained from a manuscript drafted in 2010 by Leroy Creswell of the University of Florida Sea Grant Program (Creswell, 2010). This labor value of \$8,400 was then adjusted from 2010 to 2015 dollars and divided equally between the aquaculture and hydroponic components.

Tables 1 shows a general breakdown of the system capital costs. For a complete cost breakdown, see Appendices 1 and 2.

Table 1: Capital cost of aquaponic system

| <u>Aquaculture Component:</u> | <u>Cost</u> | <u>Annual Depreciation</u> |
|-------------------------------------|---------------------|----------------------------|
| Tanks | \$ 16,122.99 | \$ 819.85 |
| Plumbing | \$ 4,194.53 | \$ 442.25 |
| Aeration | \$ 1,889.73 | \$ 1,046.08 |
| Labor | \$ 4,566.87 | \$ 228.34 |
| <i>Aquaculture Total</i> | <i>\$ 26,774.12</i> | <i>\$ 2,536.52</i> |
| | | |
| <u>Hydroponic Component:</u> | | |
| Tanks | \$ 12,874.71 | \$ 1,531.13 |
| Plumbing | \$ 2,114.41 | \$ 105.72 |
| Aeration | \$ 1,794.02 | \$ 819.33 |
| Labor | \$ 4,566.87 | \$ 228.34 |
| <i>Hydroponic Total</i> | <i>\$ 21,350.00</i> | <i>\$ 2,684.53</i> |
| | | |
| <i>Total Aquaponic System Cost:</i> | \$ 48,124.12 | \$ 5,221.05 |

It should be noted that the cost of land is not included in this study as it is assumed that the land was already purchased. The average cost of an acre of farm land in Arkansas was listed at \$3,050 for 2015 (USDA NASS, 2015). The CA2 system requires a little over an eighth of an acre (0.05 ha), giving an estimated average cost of land investment of \$381.25. The installation of a well or rainwater catchment reservoir should also be considered if not already included with the property, or if municipal water utilities are unavailable. Online sources have listed the price of installing a well pump between \$900 and \$2,100 (Smith, 2015). If a well were not already present on the property, there would be additional fees associated with drilling which vary depending on the depth and location of the well. Also, depending on the location, there may be additional costs pertaining to permits or taxes associated with building and operating the system, as well as possible permits required for the production and sale of certain agricultural products.

3.1.1.2 Environmental Control

In order to obtain year-round production in Arkansas, additional structures and equipment were necessary to control climate and maintain optimal growing conditions for the fish, bacteria and plants. The intolerance of tilapia to lower water temperatures is well documented and presents a serious constraint for commercial culture in temperate regions. Although optimal growth for tilapia is achieved at water temperatures ranging from 81 to 84°F (27 to 29°C), these temperatures are too high to successfully sustain the growth and survivability of plants and beneficial bacteria. In addition, UVI researchers found that water temperatures higher than 82°F (28°C) resulted in fish mortality brought on by an unidentified bacterial pathogen (Rakocy, 2000).

Other studies have shown that in hydroponic growing conditions, the air temperature may exhibit a wider range than traditional farming methods will allow. Lee and Takakura found that spinach may be successfully grown in temperatures as high as 91°F (33°C), given that the root-zone temperature is maintained at a range between 72°F (22°C) and 79°F (26°C) (Lee and Takakura, 1995). Alternately, researchers with the Alabama Cooperative Extension System, found that hydroponic plants could be successfully grown at temperatures as low as 55°F (13°C), given the root-zone temperature is maintained at 75°F (24°C). Using this information, as well as that gathered by researchers from UVI, it was determined that the water within the aquaponics system should be maintained at 75°F (24°C) with an allowable air temperature range of 55-90°F (13-32°C), in order to achieve optimal fish, bacterial and plant growth.

Water Temperature and Quality Control

Temperature control calculations generally utilize a form of measurement known as the British thermal unit (BTU) to determine the amount of energy necessary to heat or cool a

substance (i.e. air or water). To calculate heating and cooling costs it was necessary to first determine the number of BTU's required to maintain the optimal temperature range. As previously stated, it was decided that the water temperature of the system should be maintained at 75°F (24°C) and air temperature held at a range of 55-90°F (13-32°C), in order to achieve optimal fish and plant growth.

After contacting several aquaculture retailers and water heating experts, it was determined that a geothermal heat pump would be the most efficient means to maintain water temperature within the system (Crisp, 2015; Miller, 2015). Using the knowledge that it requires one BTU to heat one pound of water by one degree Fahrenheit, it was determined that 240,000 BTU's of energy would be necessary to heat the 30,000 gallons (240,000 lbs.) of water in the CA2 system by one degree Fahrenheit per hour. The heat pump selected for the study was capable of supplying 136,000 BTU's therefore two units were necessary, resulting in a total output of 262,000 BTU. Having the dual function of both heating and cooling, the heat pump would be used during the winter and summer months to maintain the optimal 75 degree temperature goal.

As fish and plants each require optimal temperature, pH and dissolved nutrient values, water quality monitoring and measurement plays a very important role in successful aquaponic food production. There are many products on the market for measuring water quality, ranging from prices of \$10 for basic pH testing kits, to hundreds of dollars for more high-tech, multifunction devices. For a small, backyard aquaponic system, the \$10 pH kit and an inexpensive thermometer should suffice. However, for a larger system such as the CA2 system, it was determined worthwhile to invest in more advanced equipment.

Greenhouse Structure, Covering, Controls and Installation

A variety of methods could be used to maintain optimal air and water temperature. As water interacts directly with the fish, bacteria and plants, maintaining optimal water temperature is very important for the success of an aquaponic system. Water temperature can best be controlled through the use of water heaters or by holding the air temperature at the optimal level. To control the air temperature, farmers may choose gas, electric, biomass or geothermal heaters in combination with fans, vents, cooling pads and shade cloth. In either case, a structure to house the system is likely required in order to most efficiently heat or cool the air and water.

Prices for greenhouses vary considerably depending on the greenhouse size and materials used to build the structure. In this sense, the width of the system, as well as the required temperature regulation, present a major problem when searching for affordable greenhouse options for the CA2 system. Literature published by the University of Arkansas – Division of Agriculture suggests that a Quonset-style greenhouse with heating and cooling capacities may cost in the \$4.00 per square foot range (Robbins, 2010). However, after speaking to several retailers, this estimate was found to be inaccurate when dealing with greenhouse structures of widths greater than 30 feet. The size of the CA2 system requires a greenhouse that's at least 42' x 146'. One retailer stated that greenhouse widths over 30 feet may increase total costs by as much as 30 percent, therefore this factor should be taken into consideration when designing aquaponics systems for climates requiring environmental control (Valdman, 2015). Since the UVI CA2 system carries a specific design, it was not possible to use a thinner greenhouse for this study and a 6,552 square foot, gutter-connected greenhouse with dimensions of 42' x 156' was selected (Denten, 2015).

When heating or cooling is necessary, as in this case, the greenhouse covering material must also be carefully considered. While certain materials such as glass allow for excellent light penetration and carry a long lifespan, these materials are significantly more expensive and less insulating than other common materials. Insulating properties of different materials can be measured by their R-values. A high R-value indicates a greater degree of insulation, therefore the amount of energy required to maintain temperature in a specific space is reduced as the R-value increases. With an R-value of 1.25, double-polyethylene film covering has become very popular among greenhouse growers as it is relatively inexpensive and able to maintain temperature more efficiently than other alternatives. The major drawback to this type of covering is its short lifespan. The covering on a double-polyethylene greenhouse will need to be replaced every 2-4 years but even with this drawback, double-polyethylene was chosen as the covering used for the greenhouse in this study. This was primarily due to its high insulation factor and the availability of data regarding light intensity measurements taken using this type of greenhouse.

To avoid additional labor associated with greenhouse operation, many large greenhouses come equipped with control panels to monitor inside conditions. These panels can be set to the optimal specifications desired by the farmer, allowing for automatic and remote environmental monitoring and control. Additional costs are also incurred for installation of the greenhouse, shade system, equipment and controls as shown later in Table 5.

Air Heating, Cooling, and Circulation

To determine the amount of energy necessary to heat the air of the greenhouse, a calculation involving the greenhouse surface area, the greenhouse covering's heat loss value,

desired inside temperature, and average lowest outside temperature was used (ACF Greenhouses, 2015). The formula was as follows:

$$\text{BTU} = \text{Greenhouse Surface Area} * (\text{Inside Temp.} - \text{Outside Temp.}) * \text{Heat Loss Value}$$

With a greenhouse surface area of 11,800 ft², a desired inside temperature of 55°F, average lowest outside temperature of 20°F, and heat loss value of 0.7 for the double polyethylene covering, the maximum energy required to heat the greenhouse air during the coolest season was estimated to be 289,100 BTU's, assuming outside temperatures in the 20°F (-7°C) range.

Table 2 compares the estimated cost of annual heating for a greenhouse in Arkansas by use of natural gas, biomass, electricity and propane at different desired temperatures in 2015. These costs were calculated using the formula mentioned above, combined with monthly average temperature data obtained from the National Oceanic and Atmospheric Administration - National Centers for Environmental Information (NOAA NCEI, 2015). The most recent monthly natural gas, electricity and propane price data were obtained through the U.S. Energy Information Administration (US EIA, 2015a,b,c). The price of biomass was found by averaging the listed price values for wood pellets of several online retailers and was determined to cost approximately \$300/ton. Energy prices used for heating and cooling calculations can be found in Appendix 3.

Table 2: Annual energy cost of greenhouse heating

| Energy Source: | 50 F | 55 F | 60 F | 65 F | 70 F | 75 F |
|-----------------------|-------------|-------------|-------------|-------------|-------------|-------------|
| Natural Gas | \$ 965 | \$ 1,853 | \$ 3,036 | \$ 4,345 | \$ 6,045 | \$ 7,876 |
| Biomass | \$ 2,160 | \$ 4,173 | \$ 6,876 | \$ 9,893 | \$ 13,818 | \$ 18,025 |
| Electricity | \$ 2,646 | \$ 5,121 | \$ 8,450 | \$ 12,174 | \$ 17,032 | \$ 22,250 |
| Propane | \$ 2,907 | \$ 5,618 | \$ 9,259 | \$ 13,317 | \$ 18,594 | \$ 24,242 |

This indicates that natural gas would be the most cost effective means to heat the greenhouse air at any desired temperature. Because of this, natural gas heaters were chosen as the primary air heating method for this study. In order to meet the necessary BTU requirement, it was determined that two 160,000 BTU natural gas heaters be utilized. It should be noted however, that natural gas may not be readily available in all areas. In such cases, other heating options should be explored.

As temperatures may reach upwards of 90°F (32°C) during Arkansas summers, cooling systems are also necessary for the optimal growth of greenhouse vegetables. Some common mechanisms for cooling the air include fans, ventilation, shade cloth and cooling pads. After speaking to several retailers and experts, it was determined that each of these items were necessary to combat summer heat and keep the greenhouse temperature below 90 degrees during the hottest times of the year.

Additional fans are also required in order to maintain air circulation within a greenhouse or other indoor growing environment. To provide this, fans known as horizontal airflow fans (HAFs) are used to efficiently move air throughout enclosed growing environments. For this study, it was suggested that 6, 20” HAFs be used for air circulation throughout the hydroponic growing area (Denten, 2015).

Supplemental Lighting

The location of the U.S. Virgin Islands allows for fairly consistent growing seasons in terms of natural light intensity. However, for states residing in temperate climates, the addition of supplemental lighting is necessary in order to maintain consistent plant growth throughout the year. To most efficiently provide supplemental light to their plants, growers must first determine how much additional light is necessary. This can be done by analyzing natural light intensity.

Light intensity can be measured in a number of ways. Some of the most common units for measuring light are the foot-candle, lux and $\mu\text{mol per m}^2 \text{ per s}^2$ of photosynthetically active radiation (PAR). Although these measurements can be very useful to researchers, they all share the limitation of giving only instantaneous readings and do not accurately represent the amount of light a plant receives over the course of a day. A more accurate representation of daily light intensity is achieved through use of the daily light integral (DLI). DLI measures the amount of PAR received each day as a function of light intensity and duration. It allows researchers to determine the amount of PAR received over the course of a day and is quickly becoming an important tool for greenhouse growers (Torres, 2009).

To determine the amount of monthly supplemental light necessary for greenhouse growers in Arkansas, a tool called DLICALC was used. This tool was developed in 2013 through a collaboration with Purdue University and the University of New Hampshire. Its purpose is to aid growers in calculating the amount of DLI coming from a supplemental light source and to estimate the number of hours of lamp operation required to achieve a target DLI value in their greenhouses (DLICALC, 2015).

Figure 5 shows the monthly outdoor DLI values across the continental U.S., however when enclosed in a greenhouse, the actual DLI would be some percentage less than that shown on the map, sometimes as much as 60% lower. Because there is currently no data for DLI measured in a double polyethylene greenhouse in Arkansas, these values were estimated using data provided by Dr. Roberto Lopez of Purdue University. The data, measured from a double polyethylene greenhouse located in West Lafayette, Indiana, was used to estimate Arkansas' greenhouse DLI by examining the differences between Arkansas' and Indiana's outdoor DLI and adjusting the Indiana data accordingly (Appendix 4).

Figure 5: Maps of monthly outdoor DLI throughout the United States

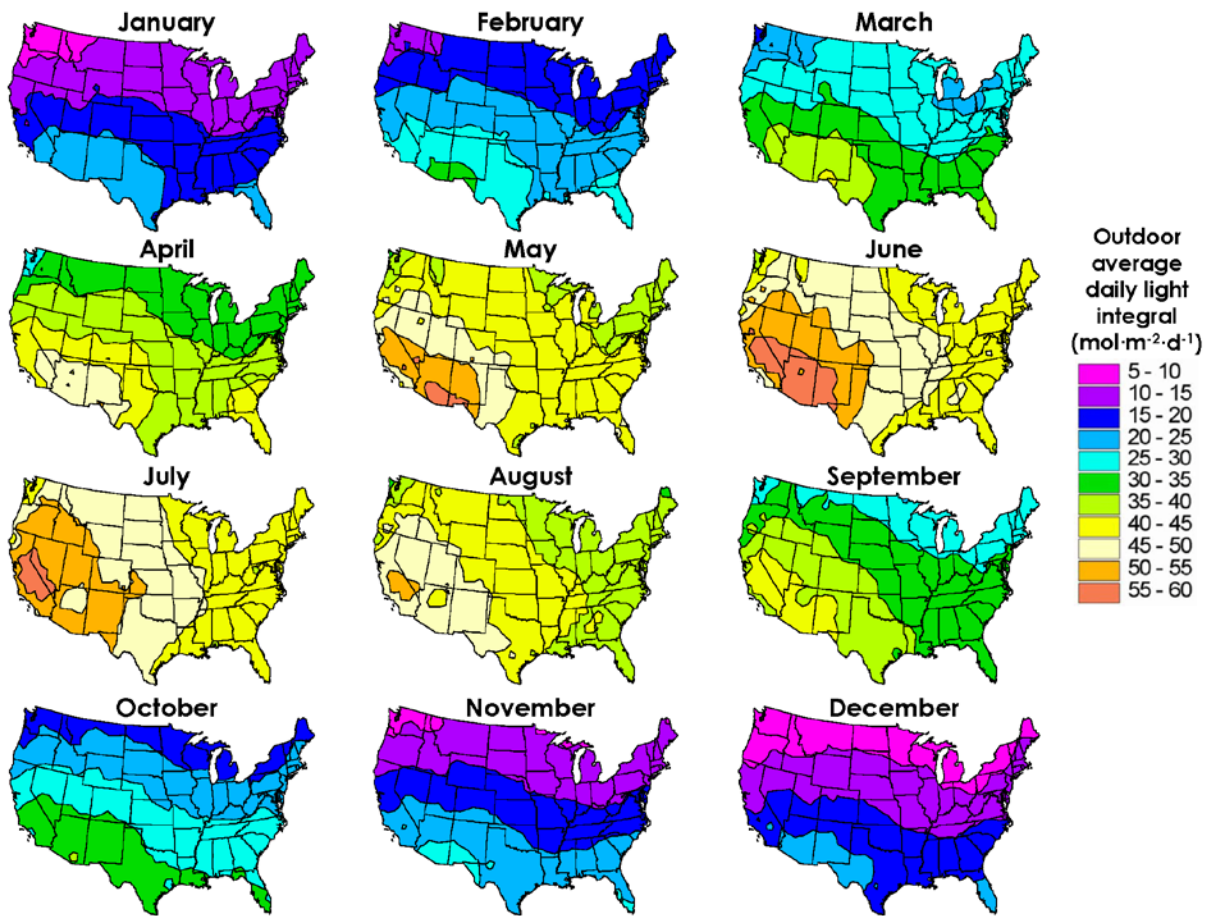

Maps developed by Jim Faust, Clemson University

Source: James E. Faust, Clemson University, 2002

Once the greenhouse DLI was calculated, it was necessary to determine the amount of supplemental DLI necessary for optimal plant growth. In the 2013 article *Daily Light Integral (DLI) and greenhouse tomato production*, Dr. Lynette Morgan discusses optimal DLI values for leafy and flowering crops, specifically hydroponic lettuce and greenhouse tomatoes. Here, the recommended light requirement was listed as 14-16 mol m⁻² d⁻¹ for leafy crops such as lettuce and 22-30 mol m⁻² d⁻¹ for flowering crops like tomatoes. The following tables show the estimated monthly supplemental DLI required to grow both leafy, and flowering crops in a double polyethylene greenhouse in Arkansas.

Table 3: Daily light necessary to achieve optimal DLI for leafy crops

| Arkansas Daily Light Integral | | | | | | Hours of Supplemental Light | | |
|-------------------------------|-------------|------------------|---------------------|-------------|------------|-----------------------------|------|-------|
| Month | Outdoor DLI | Ave. Outdoor DLI | Estimated DLI in GH | Optimal DLI | Difference | 400W | 600W | 1000W |
| Jan | 15-20 | 18 | 11 | 16 | 5 | 3.47 | 2.31 | 1.39 |
| Feb | 25-30 | 28 | 21 | 16 | -5 | - | - | - |
| March | 30-35 | 33 | 20 | 16 | -4 | - | - | - |
| April | 35-40 | 38 | 24 | 16 | -8 | - | - | - |
| May | 40-45 | 43 | 23 | 16 | -7 | - | - | - |
| June | 45-50 | 48 | 30 | 16 | -14 | - | - | - |
| July | 45-50 | 48 | 34 | 16 | -18 | - | - | - |
| Aug | 40-45 | 43 | 28 | 16 | -12 | - | - | - |
| Sept | 30-35 | 33 | 17 | 16 | -1 | - | - | - |
| Oct | 25-30 | 28 | 17 | 16 | -1 | - | - | - |
| Nov | 15-20 | 18 | 13 | 16 | 3 | 2.08 | 1.39 | 0.83 |
| Dec | 15-20 | 18 | 11 | 16 | 6 | 4.17 | 2.78 | 1.67 |

Source: Values for table calculations were obtained using the University of New Hampshire's DLICALC tool, in combination with individual research conducted by Drs. Jim E. Faust, Roberto Lopez and Lynette Morgan.

Table 4: Daily light necessary to achieve optimal DLI for flowering crops

| Arkansas Daily Light Integral | | | | | | Hours of Supplemental Light | | |
|-------------------------------|-------------|------------------|---------------------|-------------|------------|-----------------------------|------|-------|
| Month | Outdoor DLI | Ave. Outdoor DLI | Estimated DLI in GH | Optimal DLI | Difference | 400W | 600W | 1000W |
| Jan | 15-20 | 18 | 11 | 26 | 15 | 10.42 | 6.94 | 4.17 |
| Feb | 25-30 | 28 | 21 | 26 | 5 | 3.47 | 2.31 | 1.39 |
| March | 30-35 | 33 | 20 | 26 | 6 | 4.17 | 2.78 | 1.67 |
| April | 35-40 | 38 | 24 | 26 | 2 | 1.39 | 0.93 | 0.56 |
| May | 40-45 | 43 | 23 | 26 | 3 | 2.08 | 1.39 | 0.83 |
| June | 45-50 | 48 | 30 | 26 | -4 | - | - | - |
| July | 45-50 | 48 | 34 | 26 | -8 | - | - | - |
| Aug | 40-45 | 43 | 28 | 26 | -2 | - | - | - |
| Sept | 30-35 | 33 | 17 | 26 | 9 | 6.25 | 4.17 | 2.5 |
| Oct | 25-30 | 28 | 17 | 26 | 10 | 6.94 | 4.63 | 2.78 |
| Nov | 15-20 | 18 | 13 | 26 | 13 | 9.03 | 6.02 | 3.61 |
| Dec | 15-20 | 18 | 11 | 26 | 16 | 11.11 | 7.41 | 4.44 |

Source: Values for table calculations were obtained using the University of New Hampshire's DLICALC tool, in combination with individual research conducted by Drs. Jim E. Faust, Roberto Lopez and Lynette Morgan.

Based on this, it was determined that only a small amount of supplemental light would be necessary during the months of November, December and January for leafy crops in Arkansas greenhouses. For flowering crops, supplemental light would also be required for November – January with additional lighting required for the months of February, March, April, May, September and October. For the purposes of this paper, supplemental lighting costs will be included for the growing of leafy vegetables, however in practice, it's likely that the cost of installing and operating the lighting would outweigh the production benefits received. But in the case of flowering plants, supplemental lighting appears necessary in order to achieve optimal, year-round growth.

In regard to supplemental lighting, there are many options available. Some of the most common lights include fluorescent, metal halide, high-pressure sodium and LED's. After speaking to several experts in the fields of greenhouse and indoor food production, it was determined that metal halide lighting be used for this study as it is the preferred choice for growing leafy crops. For flowering crops however, high-pressure sodium lighting should also be considered. Over the past few years, LED lighting has shown potential as an effective supplemental lighting alternative, however high initial costs continue to hinder its use on a commercial scale.

Total Capital Cost for Environmental Control

Based on extensive research as outlined above, it was determined that the CA2 aquaponic system be housed in a 42 x 156 foot, double-polyethylene greenhouse with installed with additional equipment to control water temperature, air temperature, air circulation and light intensity. As water temperature control is of greatest importance to fish production, these costs were attributed to the aquaculture component of the system. As air temperature control, air circulation and supplemental lighting are only necessary for plant production, these costs were attributed to the hydroponic component of the system. The costs of these environmental control items are listed in Table 5. A complete breakdown of costs can be found in Appendix 1 and 2.

Table 5: Capital cost of environmental control

| <u>Aquaculture Component:</u> | <u>Cost</u> | <u>Annual Depreciation</u> |
|---|----------------------|----------------------------|
| Water Temperature and Quality Control | \$ 10,147.00 | \$ 703.00 |
| <i>Aquaculture Total</i> | <i>\$ 10,147.00</i> | <i>\$ 703.00</i> |
| | | |
| <u>Hydroponic Component:</u> | | |
| Greenhouse Structure, Covering, Controls and Installation | \$ 155,515.00 | \$ 7,836.85 |
| Air Heating, Cooling and Circulation | \$ 28,443.83 | \$ 2,523.24 |
| Supplemental Lighting | \$ 8,423.65 | \$ 604.91 |
| <i>Hydroponic Total</i> | <i>\$ 192,382.48</i> | <i>\$10,965.00</i> |
| | | |
| <i>Total Environmental Control Cost:</i> | \$ 202,529.48 | \$11,668.00 |

3.1.2 Determination of Variable Costs

Variable cost estimates were obtained through examination of existing literature and by contacting experts and retailers in the fields of aquaponics, aquaculture and hydroponics. Fingerling and seedling costs were obtained through online retailers. Estimates for the annual use of feed, iron chelate, KOH and CaOH come from Rakocy *et al.*, 2004a. Time and cost estimates for management and other labor come from Bailey *et al.*, 1997. It was assumed that one CA2 aquaponic system could be operated by one manager with the cost of this labor equally divided between the aquaculture and hydroponic components. The cost of water is not included as it is assumed that either well water or captured rainwater would be used for the system with costs for either method being negligible given the relatively small amount of water used daily by the CA2 system.

A discussion of utility costs associated with aquaponic system operation, as well as environmental control is included in the following sections.

3.1.2.1 Fingerlings and Seedlings

With the aquaponic system in full operation, one tilapia tank should be harvested every six weeks and one fourth of the hydroponic tanks harvested each week. To maintain the same level of production as UVI, it would be necessary to stock 600 fingerlings every six weeks, or approximately 4,800 fingerlings per year. After speaking to tilapia growers in Arkansas, the average price per fingerling was determined to be approximately \$1.50. It was also noted, however, that there are presently no tilapia growers in Arkansas able to consistently supply the number of fish required for the CA2 system (Stringer, 2015).

The hydroponic component consists of 72 sheets of floating rafts, each capable of producing 48 heads of Romaine lettuce. With staggered production, 18 sheets would be harvested each week, requiring a replacement of 864 lettuce seedlings per week, resulting in an approximate purchase of 45,792 lettuce seedlings annually. For basil production in the CA2 system, each sheet would hold 48 plants but instead of harvesting the entire plant every 4 weeks, as consistent with Rakocy *et al.*, the basil would be harvested in a “cut and come again” manner, requiring a replacement of 3,456 basil seedlings every 3 months, resulting in an approximate purchase of 13,824 basil seedlings per year (Rakocy, 2004a). Seedlings could be purchased from online retailers at a price of \$0.35 for lettuce and \$0.45 for basil. Table 6 breaks down the annual input costs for fingerlings and seedlings.

Table 6: Annual fingerling and seedling cost

| <u>Aquaculture Component:</u> | <u>Unit</u> | <u>Quantity</u> | <u>Cost per Unit</u> | <u>Total Cost</u> |
|-------------------------------|-------------|-----------------|----------------------|-------------------|
| Tilapia Fingerlings | ea. | 4,800 | \$ 1.50 | \$ 7,200.00 |
| <u>Hydroponic Component:</u> | | | | |
| Lettuce Seedlings | ea. | 45,792 | \$ 0.35 | \$16,027.20 |
| Basil Seedlings | ea. | 13,824 | \$ 0.45 | \$ 6,220.80 |

3.1.2.2 Other Inputs: Fish Feed, Iron Chelate, Potassium Hydroxide, Calcium Hydroxide

In addition to supplying fingerlings and seedlings, other primary inputs are necessary for the successful operation of the CA2 system. These include: fish feed, iron chelate, potassium hydroxide and calcium hydroxide. Fish feed serves the dual purpose of supplying nutrients and energy for fish growth, with the byproducts being utilized for plant growth. Iron must also be added to the system as iron is essential to optimal plant growth but is not supplied by aquaculture waste production. During the process of nitrification, pH is consistently being lowered, therefore the occasional addition of a base is necessary in order to raise the system pH. Potassium hydroxide and calcium hydroxide each play dual roles in both providing essential nutrients for plant growth and maintaining optimal pH throughout the system.

As reported in 1997 by Rakocy *et al.*, the optimum daily feed to plant growing area ratio for tilapia and lettuce was determined to be 57 grams of feed per square meter of hydroponic growing area. This ratio results in an approximate feed requirement of 4,452 kg (9,815 lbs.) per year. A separate study found the approximate annual addition of iron chelate, potassium hydroxide and calcium hydroxide to be 32.83, 38.85 and 40.65 kilograms, respectively. Prices for these items were found through an online search of retailers selling in bulk quantities.

Throughout this paper, any item dealing with water or water quality has been attributed to the aquaculture component. However, because iron chelate is added solely as a supplement for plant production, this item was included under variable costs associated with the hydroponic component. Bailey *et al.* include the variable cost of supplies in their enterprise budgets for tilapia production. As the contents of these miscellaneous supplies were not specified, the listed value was taken from their report, inflated from 1997 to 2015 dollar values, and included as an input for this study. Table 7 breaks down the annual costs for all other input items.

Table 7: Annual other input cost

| <u>Aquaculture Component:</u> | <u>Unit</u> | <u>Quantity</u> | <u>Cost per Unit</u> | <u>Total Cost</u> |
|--|-------------|-----------------|----------------------|---------------------|
| Feed | lb. | 9,815 | \$ 0.70 | \$ 6,870.50 |
| Potassium Hydroxide (KOH) | lb. | 86 | \$ 1.50 | \$ 128.48 |
| Calcium Hydroxide (Ca(OH) ₂) | lb. | 88 | \$ 0.60 | \$ 52.91 |
| Miscellaneous Supplies | unit | 1 | \$ 3,587.32 | \$ 3,587.32 |
| <i>Aquaculture Total</i> | | | | \$ 10,639.20 |
| | | | | |
| <u>Hydroponic Component:</u> | | | | |
| Iron Chelate | lb. | 72 | \$ 11.52 | \$ 833.82 |
| Boxes | ea. | 1,908 | \$ 2.00 | \$ 3,816.00 |
| <i>Hydroponic Total</i> | | | | \$ 4,649.82 |
| | | | | |
| <i>Total Other Input Cost:</i> | | | | \$ 15,289.02 |

3.1.2.3 Labor

Following the work of Bailey *et al.*, it was assumed that the operation of one CA2 system could be maintained by one manager being paid a salary of \$30,000. After adjusting the 1997 salary to 2015 dollars, an aquaponic farm manager could be expected to make around \$44,416 in 2015. A survey conducted by Payscale.com confirmed this estimate showing a median farm manager salary of \$43,444 (Payscale.com, 2015).

Since the manager's duties include the operation and maintenance of both the aquaculture and hydroponic components, during the calculation of variable labor costs for the individual components, the manager's salary was divided evenly between each component. This resulted in a total annual labor cost of \$22,208 for the aquaculture component and \$22,208 for the hydroponic component as shown in Table 8.

Table 8: Annual labor cost

| <u>Aquaculture Component:</u> | <u>Unit</u> | <u>Quantity</u> | <u>Cost per Unit</u> | <u>Total Cost</u> |
|-------------------------------|-------------|-----------------|----------------------|---------------------|
| Management | unit | 0.5 | \$ 44,416.00 | \$ 22,208.00 |
| <i>Aquaculture Total</i> | | | | \$ 22,208.00 |
| | | | | |
| <u>Hydroponic Component:</u> | | | | |
| Management | unit | 0.5 | \$ 44,416.00 | \$ 22,208.00 |
| <i>Hydroponic Total</i> | | | | \$ 22,208.00 |
| | | | | |
| <i>Total Labor Cost:</i> | | | | \$ 44,416.00 |

If the farm were to expand by adding additional system units, additional workers might be necessary for maintenance and hired labor positions. In their paper, Bailey *et al.* determined the cost of this extra labor to be approximately \$15,000 per worker for both maintenance and hired labor positions. Following the methods described in the previous section, this value was adjusted from 1997 to 2015 values resulting in an additional cost of \$22,207.94 per worker, if necessary.

3.1.2.4 Utilities

Utility costs are those related to the supplying of energy required to operate and maintain optimal system production. This includes electricity used to run the water pump and air blowers, as well as any additional energy required for environmental control. For environmental control, electricity was used to supply power to the heat pumps, fans and vents, while natural gas was used to supply power to the air heaters. These costs were estimated using available temperature data obtained from the National Oceanic and Atmospheric Administration - National Centers for Environmental Information in combination with energy data from the U.S. Energy Information Administration (NOAA NCEI,2015; US EIA, 2015 a,b).

Aquaponic System Utility Cost

Based on system specs reported by Rakocy *et al.*, the operation of the aquaponic system itself would require a total of 2.17 kW of electricity. Of these 2.17 kilowatts, 1.47 kW were necessary to run the pump and air blowers for the aquaculture component, while 0.74 kW were used to provide aeration for the hydroponic component (Rakocy, 2004b). These annual costs are broken down in Table 9.

Table 9: Annual system utility cost

| <u>Aquaculture Component:</u> | <u>Energy Use</u> <u>(kW)</u> | <u>Total Cost per Year</u> |
|-----------------------------------|----------------------------------|--------------------------------|
| Water Pump | 0.37 | \$ 261.41 |
| Air Blowers | 1.1 | \$ 777.15 |
| <i>Aquaculture Total</i> | | <hr/> <u>\$ 1,038.56</u> |
| | | |
| <u>Hydroponic Component:</u> | | |
| Air Blower | 0.74 | \$ 522.81 |
| <i>Hydroponic Total</i> | | <hr/> <u>\$ 522.81</u> |
| | | |
| <i>Total System Utility Cost:</i> | | <hr/> <hr/> <u>\$ 1,561.37</u> |

Heating and Cooling Utility Cost

The selected geothermal heat pump units would be supplying a total output of 262,000 BTU's, resulting in a water temperature increase of approximately 1.09°F per hour under ideal conditions. Assuming that well water with an initial temperature of 50°F (10°C) were used, it would take both heat pumps running for approximately 23 hours to initially heat the system water to the optimal temperature of 75°F (24°C). At 28 amps per unit, the heat pumps would draw about 12.3 kilowatts of electricity per hour. Meaning that, with an average of electricity cost of \$0.08 per kilowatt hour, the cost of initially heating the system water would be approximately \$22.63.

Once the optimal heating temperature were reached, the heat pump units would cycle on and off to maintain that temperature. The run time of the units would be dependent on the temperature of the surrounding air as well as the temperature and quantity of make-up water which must be added at various times to replace water lost to filter cleaning, evaporation and plant absorption. It was estimated that the units would run an average of 6 hours per day resulting in a cost of \$5.90 per day for water heating and cooling (Crisp, 2015; Miller, 2015).

To calculate the energy cost of heating the greenhouse air, average monthly air temperatures obtained from the National Oceanic and Atmospheric Administration - National Centers for Environmental Information were used in conjunction with the previously described BTU formula [BTU = Greenhouse Surface Area * (Inside Temp. – Outside Temp.) * Heat Loss Value] to estimate the expected BTU volume necessary to maintain a minimum temperature of 55°F (13°C) inside the greenhouse (Appendix 5). The use of supplemental lighting would generate a significant amount of additional heat. With each 1000-watt metal halide fixture putting off 3,412 BTU's, the 27 fixtures would generate a total of 92,124 BTU's per hour of operation. This value was multiplied by the number of hours that the lights would be operated per day, then divided by 24 to obtain the average hourly BTU put off by the lights per day. The resulting value was then subtracted from the original BTU estimate to obtain a net BTU value, giving the estimated amount of remaining hourly energy required from the natural gas heaters.

Natural gas contains 1,050 BTU's of energy per cubic foot so this value was divided into the net BTU requirement in order to estimate the amount of natural gas needed per hour to heat the greenhouse. The most recent monthly price values from the U.S. Energy Information Administration were used to estimate the annual cost of heating using natural gas heaters. This value was found to be \$1,710.46. These calculations are broken down in Appendix 6.

One can estimate that the inside temperature of a greenhouse may be 10 to 20 degrees Fahrenheit warmer than the outside air due to solar gain. When combining this knowledge with monthly temperature data from the National Oceanic and Atmospheric Administration - National Centers for Environmental Information it was found that, in Arkansas, greenhouse cooling mechanisms would likely be necessary from May through September as greenhouse temperatures during these months were likely to exceed 90 degrees. For this study, high temperatures were controlled using exhaust fans and evaporative cooling pads. As nighttime and evening temperatures are expected to drop back into the allowable temperature range, it was estimated that the fans would be required to run for approximately 8 hours during the months of May and September and 16 hours during the hottest months of June, July and August. With the use of 4 exhaust fans at 1.15 kW each, the expected annual cost of cooling the greenhouse was determined to be \$746.20.

As airflow must be maintained throughout the greenhouse, horizontal airflow fans (HAFs) should be used during times when the cooling exhaust fans are not in operation. This means that during the cooler months, HAF's should be running at all times. During the summer months, these fans will shut off while the cooling system is in operation in order to allow proper airflow from the cooling pads across the greenhouse. With 6 HAFs each pulling 0.23 kW, the expected annual cost of air circulation was determined to be \$732.80.

Supplemental Lighting Utility Cost

As previously discussed, the growth of leafy vegetables in a greenhouse in Arkansas would require supplemental lighting during the months of November, December and January. This supplemental lighting would consist of 1000 watt metal halide fixtures running for approximately 0.83, 1.67 and 1.39 hours daily during the respective months. Energy price data

from the U.S. Energy Information Administration was used to calculate the annual cost of supplemental lighting and was determined to be \$246.82.

Table 10 shows the annual utility costs attributable to environmental control systems. A monthly breakdown of these values can be found in Appendix 7.

Table 10: Annual environmental control utility cost

| <u>Aquaculture Component:</u> | <u>Total Cost</u> |
|--|--------------------------------|
| Heat Pumps | \$ 2,172.49 |
| <i>Aquaculture Total</i> | <hr/> \$ 2,172.49 |
| <u>Hydroponic Component:</u> | |
| Natural Gas Heaters | \$ 1,852.65 |
| Exhaust Fans | \$ 755.32 |
| Horizontal Airflow Fans | \$ 748.38 |
| Supplemental Lighting | \$ 246.82 |
| <i>Hydroponic Total</i> | <hr/> \$ 3,603.17 |
| <i>Total Environmental Control Utility Cost:</i> | <hr/> <hr/> \$ 5,775.67 |

3.2 REVENUE ANALYSIS

To determine the estimated revenues attainable for the production of tilapia, lettuce and basil within a CA2 aquaponic system, a revenue analysis was performed. For the purposes of this study, it was assumed that all vegetable and fish items produced by the system would be purchased by consumers at the determined local market price. Analysis methods are further discussed in the following sections.

3.2.1 Determining Annual Production

Production estimates were based on research performed at the University of the Virgin Islands using their CA2 system. In 2004, UVI researchers noted that 4.16 metric tons (9,171

lbs.) of Nile tilapia could be produced annually by operation of the CA2 system in the U.S. Virgin Islands (Rakocy 2004b). In the publication *Aquaponic Production of Tilapia and Basil: Comparing a Batch and Staggered Cropping System*, it was projected that a CA2 system in full operation would potentially yield 5.0 metric tons (176,370 oz.) of basil annually (Rakocy, 2004a). Lettuce production in the system would be expected to yield approximately 45,792 heads of romaine lettuce per year (Rakocy, 2012). These yields were obtained by use of a staggered production method, providing weekly harvests of lettuce and basil with the harvest of tilapia occurring every 6 weeks.

3.2.2 Determining Local Market Price

Local market price data were obtained using several methods. To determine the local market price of tilapia, an online search was performed with the Google search engine, using the key words “Arkansas Asian markets” to find a listing of Asian markets in Arkansas. The search found 21 Asian markets which were each contacted by telephone to obtain price per pound values for whole tilapia. Of the 21 markets listed, 18 were able to be reached by telephone and only 13 were either willing or able to offer price information about whole tilapia. An average of these prices was used for the tilapia sale price in this study (Table 11).

Table 11: Arkansas Asian market tilapia prices

| <u>Location</u> | <u>Price/lb.</u> |
|-----------------------|------------------|
| Fort Smith | \$ 1.99 |
| Hot Springs | \$ 1.99 |
| Little Rock | \$ 2.49 |
| Little Rock | \$ 4.59 |
| Little Rock | \$ 2.50 |
| Rogers | \$ 2.79 |
| Siloam Springs | \$ 1.79 |
| Springdale | \$ 2.86 |
| Springdale | \$ 2.99 |
| Springdale | \$ 2.29 |
| Springdale | \$ 2.69 |
| Springdale | \$ 2.29 |
| Waldron | \$ 1.99 |
| <i>Average Price:</i> | <u>\$ 2.56</u> |

As no reports were available regarding farmer’s market pricing for vegetables in Arkansas, 2015 summer market reports from Illinois, Kentucky, Maine, Tennessee and Vermont were used to estimate a local price per head for romaine lettuce in Arkansas (UK CCD, 2015). Prices listed online by local farmers and farmer cooperatives were used to determine the price per ounce for fresh basil in the study (Conway Locally Grown, 2015).

3.3 FINANCIAL BUDGET ANALYSIS

Information gathered in sections 3.1 and 3.2 and presented in sections 4.1 and 4.2 was used to perform financial analyses to determine the overall economic and financial feasibility of aquaponics in Arkansas. The methods of these analyses are described in the following sections.

3.3.1 Development of Enterprise Budgets

Individual enterprise budgets were developed for tilapia, lettuce and basil, breaking down costs and revenues to determine approximate net returns from each system component. The

associated costs and revenues used in these budgets were calculated using the methods discussed previously in sections 3.1 and 3.2. Budgets were also developed for three farm scenarios: 1) production of tilapia and lettuce; 2) production of tilapia and basil; and 3) production of tilapia, lettuce and basil; in order to determine net returns for each integrated system.

3.3.2 Break-Even Analysis

A break-even analysis was performed for each of the crops grown using the CA2 aquaponic system in order to determine the minimum price each crop should carry to cover total production costs. This break-even value was then used, in combination with the local market price determined in section 3.2.2, to estimate the expected profit margin of sales for each crop.

3.3.3 Examination of Cash Flows and Payback Period

Beginning with an initial investment of \$250,653.60, cash flows were calculated over a five-year period for each of the three farm scenarios described in section 3.3.1. Five year annual cash flows were calculated for each scenario by subtracting yearly fixed, operating, and interest costs from gross revenue. Annual interest payments were calculated at a rate of four percent over a twenty year term (Farm Credit Mid-America, 2015). Cash flow values were then used to calculate the approximate payback period for an investment in each farm scenario.

3.3.4 Sensitivity Analysis

As the value of certain variables are known to change from year to year, a sensitivity analysis was performed to determine the expected profitability of aquaculture and hydroponic production under varying circumstances. In order to choose the variables selected for analysis, variable costs were examined for each crop (Table 12).

Table 12: Share of variable costs for each crop

| Tilapia | | Lettuce | | Basil | |
|-----------------|----------------------|-----------------|----------------------|-----------------|----------------------|
| Variable | % Share of VC | Variable | % Share of VC | Variable | % Share of VC |
| Management | 51.3% | Management | 47.2% | Management | 63.2% |
| Fingerlings | 16.6% | Seedlings | 34.1% | Seedlings | 17.7% |
| Feed | 15.9% | Boxes | 8.1% | Electricity | 6.5% |
| Supplies | 8.3% | Electricity | 4.8% | Natural Gas | 5.3% |
| Electricity | 7.4% | Natural Gas | 3.9% | Packaging | 5.0% |
| Other | 0.4% | Iron Chelate | 1.8% | Iron Chelate | 2.4% |

This examination showed labor to be the most significant cost for each crop, representing 51.3% of variable costs for tilapia production, 47.2% for the production of lettuce and 63.2% for basil. These costs however, represent the salary of only one manager, therefore they are essentially fixed as it is necessary to employ least one person in order to operate the system. Outside of labor cost, the purchase of fingerlings and seedlings represent the next highest share of variable costs. Within the aquaculture component, 16.6% of variable costs were attributed to fingerling purchase. When looking at each hydroponic crop, the purchase of seedlings represented 34.1% and 17.7% of total variable costs for lettuce and basil, respectively. For the production of tilapia, the purchase of feed also held a significant share of total variable costs with a value of 15.9%. Other variables such as utilities, packaging and supplies had much smaller impacts on variable costs (<10%).

As a result, value changes occurring in market price, in relation to fingerling and feed cost were examined for tilapia production, while market price and seedling cost variances were examined for lettuce and basil.

CHAPTER 4

RESULTS

4.1 COST ANALYSIS

4.1.1 Fixed Cost

The total capital cost for construction of a CA2 aquaponic system in Arkansas included: 1) cost of materials and labor required to build the aquaponic system, 2) cost of additional materials and installation fees necessary to provide optimal growing conditions for tilapia, lettuce and basil in Arkansas. The total capital cost for a CA2 system, including costs associated with environmental control, was calculated by methods described in sections 3.1.1.1 and 3.1.1.2., and found to be \$250,653.60. Using straight-line depreciation methods, annual fixed costs were found to be \$3,239.52 and \$13,649.53 for the aquaculture and hydroponic components respectively, resulting in a total annual fixed cost of \$16,889.05 as shown in Table 13.

Table 13: Capital cost of aquaponic system (including environmental control)

| <u>Aquaculture Component:</u> | <u>Cost</u> | <u>Annual Depreciation</u> |
|---|----------------------|----------------------------|
| Tanks | \$ 16,122.99 | \$ 819.85 |
| Plumbing | \$ 4,194.53 | \$ 442.25 |
| Aeration | \$ 1,889.73 | \$ 1,046.08 |
| Water Temperature and Quality Control | \$ 10,147.00 | \$ 703.00 |
| Labor | \$ 4,566.87 | \$ 228.34 |
| <i>Aquaculture Total</i> | <i>\$ 36,921.12</i> | <i>\$ 3,239.52</i> |
| | | |
| <u>Hydroponic Component:</u> | | |
| Tanks | \$ 12,874.71 | \$ 1,531.13 |
| Plumbing | \$ 2,114.41 | \$ 105.72 |
| Aeration | \$ 1,794.02 | \$ 819.33 |
| Greenhouse Structure, Covering, Controls and Installation | \$ 155,515.00 | \$ 7,836.85 |
| Air Heating, Cooling and Circulation | \$ 28,443.83 | \$ 2,523.24 |
| Supplemental Lighting | \$ 8,423.65 | \$ 604.91 |
| Labor | \$ 4,566.87 | \$ 228.34 |
| <i>Hydroponic Total</i> | <i>\$ 213,732.48</i> | <i>\$ 13,649.53</i> |
| | | |
| <i>Total Aquaponic System Cost:</i> | \$ 250,653.60 | \$ 16,889.05 |

4.1.2 Variable Cost

As discussed in section 3.1.2, total variable cost for the CA2 aquaponic system in Arkansas includes the cost of fingerlings and seedlings, fish feed, potassium hydroxide, calcium hydroxide, iron chelate, supplies, packaging, labor and utilities. Individual variable costs amounted to \$43,258.26 for tilapia, \$47,011.00 for lettuce and \$35,152.30 for basil. Outside of labor, variables contributing the most to overall costs were fingerlings and feed for tilapia production with seedlings making up the largest input cost for both lettuce and basil. The markedly lower variable cost found with basil production is directly attributable to cheaper packaging and a lower volume of seedling purchases resulting from the “cut and come again”

method used during harvest. Remaining variable costs can be reviewed in the enterprise budgets found in section 4.3.1.

4.2 REVENUE ANALYSIS

As discussed in sections 3.2.1 and 3.2.2, production values and local market prices were determined for each crop using various methods and sources. These values are used in Table 14 to determine the estimated revenues attainable by growing each crop within the CA2 aquaponic system in Arkansas, under the assumption that all crops harvested are sold at market price.

Table 14: Annual revenues from CA2 aquaponic production

| <u>Crop:</u> | <u>Unit:</u> | <u>Quantity:</u> | <u>Price:</u> | <u>Total Revenue:</u> |
|--------------|--------------|------------------|---------------|-----------------------|
| Tilapia | lb. | 9,171 | \$ 2.56 | \$ 23,477.76 |
| Lettuce | head | 45,792 | \$ 2.57 | \$ 117,685.44 |
| Basil | oz. | 176,370 | \$ 1.50 | \$ 264,555.00 |

Although basil carries the lowest market price per unit, a large production volume allows exceptional revenues totaling \$264,555.00 annually. With a high market price and relatively high production volume, revenues from lettuce production were shown to value \$117,685.44 annually, while a low production quantity and a relatively low market price resulted in tilapia revenues of only \$23,477.76, a fraction of that seen with either basil or lettuce production.

4.3 FINANCIAL BUDGET ANALYSIS

4.3.1 Enterprise Budgets

As shown in Table 15, tilapia production using the CA2 system in Arkansas experienced a net negative return of \$23,020.01. This loss of revenue was primarily attributable to high variable costs associated with tilapia production. The high cost of fingerlings and feed combined with relatively low production and market prices resulted in tilapia production within the

aquaculture component of the CA2 system being unprofitable in Arkansas. Other studies have listed the cost of fingerlings to be as low as \$0.30 each (Creswell, 2010). If this were the case in Arkansas, the negative return would decrease to \$17,260.01 per year, but would still not be enough to produce positive profits for the aquaculture component of the system. With a fixed labor cost of \$22,208.00, it appears that a combination of cheaper fingerlings and feed, as well as a significantly higher market price would be required in order to turn a profit for tilapia production in the CA2 system in Arkansas. This was further examined in section 4.3.4.

Table 15: Enterprise budget for production of tilapia

| | <u>Unit</u> | <u>Quantity per</u> | <u>Price/Cost per</u> | <u>Total Price</u> |
|--|-------------|---------------------|-----------------------|-----------------------|
| <u>Receipts:</u> | | <u>Unit</u> | <u>Unit</u> | <u>or Cost</u> |
| Tilapia | lb. | 9,171 | \$ 2.56 | \$ 23,477.76 |
| <u>Variable Costs:</u> | | | | |
| Fingerlings | ea. | 4,800 | \$ 1.50 | \$ 7,200.00 |
| Feed | lb. | 9,815 | \$ 0.70 | \$ 6,870.50 |
| Potassium Hydroxide (KOH) | lb. | 86 | \$ 1.50 | \$ 128.48 |
| Calcium Hydroxide (Ca(OH) ₂) | lb. | 88 | \$ 0.60 | \$ 52.91 |
| Electricity (water pump, air blowers, heat pump) | kWh | variable | variable | \$ 3,211.05 |
| Supplies | unit | 1 | \$ 3,587.32 | \$ 3,587.32 |
| Management | unit | 0.5 | \$ 44,416.00 | \$ 22,208.00 |
| Total Variable Cost: | | | | \$ 43,258.26 |
| Fixed Costs (Depreciation Expense): | | | | \$ 3,239.52 |
| Total Annual Cost: | | | | \$ 46,497.77 |
| Net Returns: | | | | \$ (23,020.01) |

Table 16 breaks down the costs and revenues associated with the hydroponic production of romaine lettuce within the CA2 system. Even with fixed costs more than four times higher than those associated with aquaculture production, lettuce production in the hydroponic component of the system was found to be profitable with expected net returns of \$57,024.91 annually. Although variable costs and sales price are almost the same as those seen with tilapia

production, the higher production values offset these costs, resulting in net profits for lettuce production.

It should be noted, however, that variable costs for this system are likely undervalued when compared to a stand-alone hydroponic system. This is because costs attributable to the supply of nutrients are not included for the hydroponic component of the CA2 system as they are obtained for “free” from the aquaponic component, whereas a traditional hydroponic grower would be required to purchase these nutrients for use in their systems. Using the interactive hydroponic greenhouse lettuce enterprise budget created by Ohio State University Extension, the annual cost of supplying nutrients to a stand-alone system of this size would add approximately \$600, plus the additional cost of labor required to flush the tanks and replenish nutrients (Ohio State Extension, 2011).

Table 16: Enterprise budget for production of lettuce

| <u>Receipts:</u> | <u>Unit</u> | <u>Quantity per Unit</u> | <u>Price/Cost per Unit</u> | <u>Total Price or Cost</u> |
|-------------------------------------|---------------------|--------------------------|----------------------------|----------------------------|
| Lettuce | head | 45,792 | \$ 2.57 | \$ 117,685.44 |
| <u>Variable Costs:</u> | | | | |
| Seedlings | ea. | 45,792 | \$ 0.35 | \$ 16,027.20 |
| Boxes | ea. | 1,908 | \$ 2.00 | \$ 3,816.00 |
| Iron Chelate | lb. | 72 | \$ 11.52 | \$ 833.82 |
| Electricity | kWh | variable | variable | \$ 2,273.33 |
| Natural Gas | ft ³ /hr | variable | variable | \$ 1,852.65 |
| Management | unit | 0.5 | \$ 44,416.00 | \$ 22,208.00 |
| Total Variable Cost: | | | | \$ 47,011.00 |
| Fixed Costs (Depreciation Expense): | | | | \$ 13,649.53 |
| Total Annual Cost: | | | | \$ 60,660.53 |
| Net Returns: | | | | \$ 57,024.91 |

In Table 17, the enterprise budget for the production of basil shows exceptional net returns of \$215,753.17 annually. This large return was attributable to high production values combined with a favorable market price for fresh basil. Although this budget shows high profit potential for basil grown in a CA2 system, it is based on the assumption that the farmer will sell all basil produced. Further research should be done to test the validity of this assumption by determining whether the Arkansas market can sustain high prices with this influx of basil being put on the market.

Table 17: Enterprise budget for production of basil

| <u>Receipts:</u> | <u>Unit</u> | <u>Quantity per Unit</u> | <u>Price/Cost per Unit</u> | <u>Total Price or Cost</u> |
|-------------------------------------|---------------------|--------------------------|----------------------------|----------------------------|
| Basil | oz. | 176,370 | \$ 1.50 | \$ 264,555.00 |
| <u>Variable Costs:</u> | | | | |
| Seedlings | ea. | 13,824 | \$ 0.45 | \$ 6,220.80 |
| Packaging | ea. | 176,370 | \$ 0.01 | \$ 1,763.70 |
| Iron Chelate | lb. | 72 | \$ 11.52 | \$ 833.82 |
| Electricity | kWh | variable | variable | \$ 2,273.33 |
| Natural Gas | ft ³ /hr | variable | variable | \$ 1,852.65 |
| Management | unit | 0.5 | \$ 44,416.00 | \$ 22,208.00 |
| Total Variable Cost: | | | | \$ 35,152.30 |
| Fixed Costs (Depreciation Expense): | | | | \$ 13,649.53 |
| Total Annual Cost: | | | | \$ 48,801.83 |
| Net Returns: | | | | \$ 215,753.17 |

Table 18 shows the expected net returns for an entire aquaponic system growing tilapia and romaine lettuce. Although tilapia production resulted in net losses for the aquaculture component of the system, these losses were offset by profits realized with lettuce production resulting in a net farm revenue of \$34,004.90 annually.

Table 18: Farm Scenario 1 - Tilapia and Lettuce

| | <u>Price/Cost</u> |
|-----------------------------|----------------------|
| <u>Revenue:</u> | |
| Nile Tilapia | \$ 23,477.76 |
| Lettuce | \$ 117,685.44 |
| <i>Total Revenue:</i> | <u>\$ 141,163.20</u> |
| <u>Variable Cost:</u> | |
| Nile Tilapia | \$ 43,258.26 |
| Lettuce | \$ 47,011.00 |
| <i>Total Variable Cost:</i> | <u>\$ 90,269.26</u> |
| <u>Fixed Cost:</u> | |
| Nile Tilapia | \$ 3,239.52 |
| Lettuce | \$ 13,649.53 |
| <i>Total Fixed Cost:</i> | <u>\$ 16,889.05</u> |
| <hr/> <hr/> | |
| Total Costs: | \$ 107,158.30 |
| Net Returns: | \$ 34,004.90 |

Table 19 shows the expected net returns for an entire aquaponic system growing tilapia and basil. Again, losses for the aquaculture component were offset by profits realized with hydroponic production resulting in a net farm revenue of \$192,733.16 annually.

Table 19: Farm Scenario 2 - Tilapia and Basil

| | <u>Price/Cost</u> |
|-----------------------------|-------------------------|
| <u>Revenue:</u> | |
| Nile Tilapia | \$ 23,477.76 |
| Basil | \$ 264,555.00 |
| <i>Total Revenue:</i> | <u>\$ 288,032.76</u> |
| <u>Variable Cost:</u> | |
| Nile Tilapia | \$ 43,258.26 |
| Basil | \$ 35,152.30 |
| <i>Total Variable Cost:</i> | <u>\$ 78,410.56</u> |
| <u>Fixed Cost:</u> | |
| Nile Tilapia | \$ 3,239.52 |
| Basil | \$ 13,649.53 |
| <i>Total Fixed Cost:</i> | <u>\$ 16,889.05</u> |
| Total Costs: | <u>\$ 95,299.60</u> |
| Net Returns: | \$ 192,733.16 |

Table 20 shows the expected net returns for an entire aquaponic system growing tilapia, lettuce and basil to be \$110,579.18. Although returns for this scenario were not as high as those seen with tilapia and basil production, crop diversification decreases dependence on basil as the sole profit center for the farm, reducing risk associated with changes in market sales price.

Table 20: Farm Scenario 3 - Tilapia, Lettuce and Basil

| | <u>Price/Cost</u> |
|-----------------------------|----------------------|
| <u>Revenue:</u> | |
| Nile Tilapia | \$ 23,477.76 |
| Lettuce | \$ 58,842.72 |
| Basil | \$ 132,277.50 |
| <i>Total Revenue:</i> | <u>\$ 214,597.98</u> |
| <u>Variable Cost:</u> | |
| Nile Tilapia | \$ 43,258.26 |
| Lettuce + Basil | \$ 43,871.50 |
| <i>Total Variable Cost:</i> | <u>\$ 87,129.76</u> |
| <u>Fixed Cost:</u> | |
| Nile Tilapia | \$ 3,239.52 |
| Lettuce + Basil | \$ 13,649.53 |
| <i>Total Fixed Cost:</i> | <u>\$ 16,889.05</u> |
| | |
| Total Costs: | <u>\$ 104,018.80</u> |
| Net Returns: | \$ 110,579.18 |

4.3.2 Break-Even Analysis

Table 21 shows break-even prices for the production of tilapia, lettuce and basil. Based on the results it can be concluded that, for the profitable production of tilapia in the CA2 aquaponic system in Arkansas, tilapia must be sold at a price higher than \$5.07 per pound. Whereas lettuce and basil may be sold at prices as low as \$1.32 per head and \$0.28 per ounce, respectively, before realizing net losses.

Table 21: Break-even price for aquaponic crops

| <u>Crop</u> | <u>Annual Qty. Produced</u> | <u>Total Annual Cost</u> | <u>Break-Even Price</u> |
|-------------|-----------------------------|--------------------------|-------------------------|
| Tilapia | 9,171 lbs. | \$ 46,541.04 | \$ 5.07 / lb. |
| Lettuce | 45,792 heads | \$ 59,917.19 | \$ 1.32 / head |
| Basil | 176,370 ounces | \$ 48,058.49 | \$ 0.28 / oz. |

From the break-even price, the profit margin on sales was calculated. With a margin of 83%, basil was found to be the most profitable crop, followed by lettuce with a margin of 49%. Tilapia, however, shows a negative margin of -98%, requiring the market price of tilapia to increase by at least \$2.51 in order to obtain a positive margin on sales (Table 22).

Table 22: Profit margin on sales for aquaponic crops

| <u>Crop</u> | <u>Break-Even Price</u> | <u>Market Price</u> | <u>Margin</u> |
|--------------------|--------------------------------|----------------------------|----------------------|
| Tilapia | \$ 5.07 / lb. | \$ 2.56 / lb. | (98%) |
| Lettuce | \$ 1.32 / head | \$ 2.57 / head | 48% |
| Basil | \$ 0.28 / oz. | \$ 1.50 / oz. | 82% |

4.3.3 Cash Flows and Payback Period

Tables 23, 24 and 25 show the 5-year projected cash flows for each evaluated farm scenario.

Table 23: Projected cash flows for farm scenario 1 – tilapia and lettuce

| <u>Year</u> | <u>Revenue</u> | <u>Fixed Cost</u> | <u>Variable Cost</u> | <u>Interest Cost</u> | <u>Net Revenue</u> |
|--------------------|-----------------------|--------------------------|-----------------------------|-----------------------------|---------------------------|
| 0 | \$ (250,653.60) | \$ - | \$ - | \$ - | \$ - |
| 1 | \$ 141,163.20 | \$ 1,937.95 | \$ 90,269.26 | \$ 10,026.14 | \$ 38,929.85 |
| 2 | \$ 141,163.20 | \$ 1,948.98 | \$ 90,269.26 | \$ 9,689.45 | \$ 39,255.51 |
| 3 | \$ 141,163.20 | \$ 1,937.95 | \$ 90,269.26 | \$ 9,339.29 | \$ 39,616.70 |
| 4 | \$ 141,163.20 | \$ 1,948.98 | \$ 90,269.26 | \$ 8,975.12 | \$ 39,969.84 |
| 5 | \$ 141,163.20 | \$ 7,251.84 | \$ 90,269.26 | \$ 8,596.39 | \$ 35,045.71 |

Table 24: Projected cash flows for farm scenario 2 – tilapia and basil

| <u>Year</u> | <u>Revenue</u> | <u>Fixed Cost</u> | <u>Variable Cost</u> | <u>Interest Cost</u> | <u>Net Revenue</u> |
|-------------|----------------|-------------------|----------------------|----------------------|--------------------|
| 0 | \$(250,653.60) | \$ - | \$ - | \$ - | \$ - |
| 1 | \$ 288,032.76 | \$ 1,937.95 | \$ 78,410.56 | \$ 10,026.14 | \$ 197,658.11 |
| 2 | \$ 288,032.76 | \$ 1,948.98 | \$ 78,410.56 | \$ 9,689.45 | \$ 197,983.77 |
| 3 | \$ 288,032.76 | \$ 1,937.95 | \$ 78,410.56 | \$ 9,339.29 | \$ 198,344.96 |
| 4 | \$ 288,032.76 | \$ 1,948.98 | \$ 78,410.56 | \$ 8,975.12 | \$ 198,698.10 |
| 5 | \$ 288,032.76 | \$ 7,251.84 | \$ 78,410.56 | \$ 8,596.39 | \$ 193,773.97 |

Table 25: Projected cash flows for farm scenario 3 – tilapia, lettuce and basil

| <u>Year</u> | <u>Revenue</u> | <u>Fixed Cost</u> | <u>Variable Cost</u> | <u>Interest Cost</u> | <u>Net Revenue</u> |
|-------------|----------------|-------------------|----------------------|----------------------|--------------------|
| 0 | \$(250,653.60) | \$ - | \$ - | \$ - | \$ - |
| 1 | \$ 214,597.98 | \$ 1,937.95 | \$ 87,129.76 | \$ 10,026.14 | \$ 115,504.13 |
| 2 | \$ 214,597.98 | \$ 1,948.98 | \$ 87,129.76 | \$ 9,689.45 | \$ 115,829.79 |
| 3 | \$ 214,597.98 | \$ 1,937.95 | \$ 87,129.76 | \$ 9,339.29 | \$ 116,190.98 |
| 4 | \$ 214,597.98 | \$ 1,948.98 | \$ 87,129.76 | \$ 8,975.12 | \$ 116,544.12 |
| 5 | \$ 214,597.98 | \$ 7,251.84 | \$ 87,129.76 | \$ 8,596.39 | \$ 111,619.99 |

These projected cash flows were used to calculate payback periods for aquaponic farms operating under the three farm scenarios. With low annual returns being realized for farm scenario 1, results show that it would take more than five years to recover the initial capital invested for this enterprise. For scenarios 2 and 3, the respective payback periods were found to be 1.27 and 2.17 years (Table 26). While farm scenario 2 offers the shortest payback period, the diversification of farm scenario 3, as well as its relatively short payback period make it an attractive option for investors as well.

Table 26: Payback period

| <u>Farm Scenario:</u> | <u>Payback Period (yrs.):</u> |
|-----------------------|-------------------------------|
| 1 | > 5 |
| 2 | 1.27 |
| 3 | 2.17 |

4.3.4 Sensitivity Analysis

Sensitivity analysis examined the expected revenues attainable for tilapia production at varying market prices and feed costs. The results showed that, in order for tilapia production to realize profits, an approximate 80% increase in market price accompanied by a decrease of around 60% in fingerling cost would be required (Table 27) .

Table 27: Tilapia net revenues with varying market price and fingerling cost

| | \$ 0.51 | \$ 1.54 | \$ 2.56 | \$ 3.58 | \$ 4.61 |
|---------|----------------|----------------|----------------|----------------|---------------|
| \$ 2.70 | \$ (47,562.22) | \$ (38,171.12) | \$ (28,780.01) | \$ (19,388.91) | \$ (9,997.81) |
| \$ 2.10 | \$ (44,682.22) | \$ (35,291.12) | \$ (25,900.01) | \$ (16,508.91) | \$ (7,117.81) |
| \$ 1.50 | \$ (41,802.22) | \$ (32,411.12) | \$ (23,020.01) | \$ (13,628.91) | \$ (4,237.81) |
| \$ 0.90 | \$ (38,922.22) | \$ (29,531.12) | \$ (20,140.01) | \$ (10,748.91) | \$ (1,357.81) |
| \$ 0.30 | \$ (36,042.22) | \$ (26,651.12) | \$ (17,260.01) | \$ (7,868.91) | \$ 1,522.19 |

The results are similar when looking at feed cost. Here, it was determined that a market price increase and feed cost reduction of around 80% were required to make tilapia production profitable (Table 28).

Table 28: Tilapia revenues with varying market price and feed cost

| | \$ 0.51 | \$ 1.54 | \$ 2.56 | \$ 3.58 | \$ 4.61 |
|---------|----------------|----------------|----------------|----------------|---------------|
| \$ 1.26 | \$ (47,298.62) | \$ (37,907.52) | \$ (28,516.41) | \$ (19,125.31) | \$ (9,734.21) |
| \$ 0.98 | \$ (44,550.42) | \$ (35,159.32) | \$ (25,768.21) | \$ (16,377.11) | \$ (6,986.01) |
| \$ 0.70 | \$ (41,802.22) | \$ (32,411.12) | \$ (23,020.01) | \$ (13,628.91) | \$ (4,237.81) |
| \$ 0.42 | \$ (39,054.02) | \$ (29,662.92) | \$ (20,271.81) | \$ (10,880.71) | \$ (1,489.61) |
| \$ 0.14 | \$ (36,305.82) | \$ (26,914.72) | \$ (17,523.61) | \$ (8,132.51) | \$ 1,258.59 |

Table 29 shows the break-even prices necessary with varying fingerling and feed costs.

Even with an 80% decrease in both fingerling and feed cost, the market price would have to increase by 50% in order to recover total costs.

Table 29: Break-even price with varying fingerling and feed cost

| | \$ 2.70 | \$ 2.10 | \$ 1.50 | \$ 0.90 | \$ 0.30 |
|---------|---------|---------|---------|---------|---------|
| \$ 1.26 | \$ 6.30 | \$ 5.98 | \$ 5.67 | \$ 5.36 | \$ 5.04 |
| \$ 0.98 | \$ 6.00 | \$ 5.68 | \$ 5.37 | \$ 5.06 | \$ 4.74 |
| \$ 0.70 | \$ 5.70 | \$ 5.38 | \$ 5.07 | \$ 4.76 | \$ 4.44 |
| \$ 0.42 | \$ 5.40 | \$ 5.08 | \$ 4.77 | \$ 4.46 | \$ 4.14 |
| \$ 0.14 | \$ 5.10 | \$ 4.78 | \$ 4.47 | \$ 4.16 | \$ 3.84 |

As shown in table 30, lettuce production would begin to lose profitability when both market price, and feed costs noticed changes of around 40% and 80%, respectively.

Table 30: Lettuce net revenues with varying market price and seedling cost

| | \$ 0.51 | \$ 1.54 | \$ 2.57 | \$ 3.60 | \$ 4.63 |
|---------|----------------|---------------|--------------|--------------|--------------|
| \$ 0.63 | \$ (49,945.20) | \$ (2,871.03) | \$ 44,203.15 | \$ 91,277.32 | \$138,351.50 |
| \$ 0.49 | \$ (43,534.32) | \$ 3,539.85 | \$ 50,614.03 | \$ 97,688.20 | \$144,762.38 |
| \$ 0.35 | \$ (37,123.44) | \$ 9,950.73 | \$ 57,024.91 | \$104,099.08 | \$151,173.26 |
| \$ 0.21 | \$ (30,712.56) | \$ 16,361.61 | \$ 63,435.79 | \$110,509.96 | \$157,584.14 |
| \$ 0.07 | \$ (24,301.68) | \$ 22,772.49 | \$ 69,846.67 | \$116,920.84 | \$163,995.02 |

Basil also exhibited stable profit potential with losses realized only after a combined reduction in market price and increase in seedling costs of approximately 80% (Table 31).

Table 31: Basil new revenues with varying market price and seedling cost

| | \$ 0.30 | \$ 0.90 | \$ 1.50 | \$ 2.10 | \$ 2.70 |
|----------------|--------------------|----------------|----------------|----------------|----------------|
| \$ 0.81 | \$ (867.47) | \$104,954.53 | \$210,776.53 | \$316,598.53 | \$422,420.53 |
| \$ 0.63 | \$ 1,620.85 | \$107,442.85 | \$213,264.85 | \$319,086.85 | \$424,908.85 |
| \$ 0.45 | \$ 4,109.17 | \$109,931.17 | \$215,753.17 | \$321,575.17 | \$427,397.17 |
| \$ 0.27 | \$ 6,597.49 | \$112,419.49 | \$218,241.49 | \$324,063.49 | \$429,885.49 |
| \$ 0.09 | \$ 9,085.81 | \$114,907.81 | \$220,729.81 | \$326,551.81 | \$432,373.81 |

CHAPTER 5

SUMMARY AND CONCLUSIONS

5.1 THESIS SUMMARY

This study analyzed the economic feasibility of the production of tilapia, lettuce and basil using the University of the Virgin Islands' Commercial Aquaponics 2 system within an environmentally controlled setting in Arkansas. A cost analysis utilizing straight-line depreciation found the expected fixed costs to be \$3,239.52 annually for aquaculture production and \$13,649.53 for hydroponic production. Variable costs associated with the operation of the system amounted to \$43,258.26 for tilapia, \$47,011.00 for lettuce and \$35,152.30 for basil, resulting in total annual costs of \$46,497.77, \$60,660.53 and \$48,801.83, respectively. A revenue analysis determined market prices for the crops to be \$2.56, \$2.57 and \$1.50, respectively. At these prices, only lettuce and basil were found to be profitable within the system as tilapia production realized annual net losses of \$23,020.01.

Examination of farm scenarios involving the combination of tilapia production with hydroponic production resulted in estimated net returns of \$34,004.90 for tilapia and lettuce production, \$192,733.16 for tilapia and basil, and \$110,579.18 for tilapia, lettuce and basil showing that losses from aquaponic production could be offset by revenues realized through hydroponic production. Investment payback periods were determined for each farm scenario through analysis of individual five year cash flows. With a payback period of 1.27 years, tilapia and basil production appeared to offer the lowest risk for investors, followed by tilapia, lettuce and basil with a 2.17 year payback period. Exhibiting a payback period greater than five years, the production of tilapia and lettuce was the least attractive investment option analyzed.

5.2 OTHER CONSIDERATIONS

As previously mentioned, there are several costs and other variables that were not taken into consideration within the scope of this study. The cost of land, construction of rainwater catchment tanks, equipment and labor required for well installation, and other costs associated with taxes, fees, permits and distribution are additional fixed costs that should be included in the budget, if relevant to the production system. Although the cost of water was expected to be minimal under current circumstances, future water shortages are expected in some regions, and therefore, greater consideration of water costs may be important as well.

In addition to the variable costs listed in section 3.1, the cost of marketing should also be considered. This cost would vary depending on the type of market, i.e. direct marketing versus wholesale. Direct marketing through farmers markets and community supported agriculture (CSAs) would likely result in higher costs, but could also bring a higher sale price per unit as intermediaries are cut out of the process (Alcorta, 2012). Researchers at the University of California found, however, that direct marketing's significant labor and transportation costs were great enough offset the increased revenues obtained through higher pricing. They ultimately found marketing costs per dollar of revenue to be lowest through wholesale marketing channels, with sales through community supported agriculture (CSAs) offering lower marketing costs and less overall risk than selling through farmers' markets (Hardesty, 2010).

As the CA2 system is relatively small, (1/8 acres or 0.05ha), the cost of marketing labor was assumed to be included in the overall manager salary shown in the enterprise budgets from section 4.3.1. The cost of packaging materials was also included in those budgets. Additional marketing costs that should be considered are those incurred through booth rental fees, promotional materials, signage and transportation. In Arkansas, booth rental fees range from \$5

to \$30 per day, depending on the market and season. With many markets requiring that the products be grown locally, the travel to and from market should generally be less than 100 miles per day. With gas prices averaging \$3.30 over the 2010 – 2015 period, the average cost of transportation per mile could be estimated at \$0.17 per mile (U.S. EIA, 2015d).

In regard to estimated revenues, the budgets developed in section 4.3.1 were based on the assumption that all crops produced would be sold at the estimated market value. This was evaluated under ideal circumstances and did not take into account the market capacity or potential wastage of crops not sold. After contacting several farmers, it was determined that sales of crops harvested would be approximately 75-82% for lettuce and 80-90% for basil when sold through direct markets (Tables 32 & 33).

Table 32: Percentage of total basil harvest sold

| <u>Location:</u> | <u>% of Crop Sold:</u> | <u>Market:</u> |
|-------------------------|-------------------------------|-----------------------|
| Guy | 90% | Direct - mostly CSA |
| Wynne | 80% | Direct - mostly CSA |
| Little Rock | 100%* | Wholesale |

*Estimated potential sales of aquaponically grown living plants

Table 33: Percentage of total lettuce harvest sold

| <u>Location:</u> | <u>% of Crop Sold:</u> | <u>Market:</u> |
|-------------------------|-------------------------------|-------------------------------------|
| Guy | 75% | Direct - mostly CSA |
| Wynne | 80% | Direct - mostly CSA |
| Perryville | 80% | Direct – farmers’ market |
| Evansville | 82% | Direct – restaurant/farmers’ market |
| Little Rock | 100%* | Wholesale |

*Estimated potential sales of aquaponically grown living plants

One farmer suggested that there could be strong market potential for tilapia in Little Rock when sold through Asian markets at wholesale prices. He also stated that customers preferred the taste of his aquaponic Bibb lettuce over conventionally grown, and believed there to be significant market potential in the sale of “living plants” through natural food and organic retailers such as Whole Foods (Galloway, 2015). This is consistent with what other farmers selling through direct markets stated about the sale of basil. Their findings were that basil showed the highest sales potential through the sale of whole, live plants, as opposed to selling by the bunch or pound. Many also stated that their total revenues generally come from a combination of CSA, farmers’ market and restaurant sales.

When this is taken into account, along with additional estimated marketing costs of \$10,000 per year for weekly booth rental, promotional brochures, signs and 100 miles per week of transportation; annual net returns for lettuce and basil are reduced to \$22,310.97 and \$166,069.92, respectively. If sold through wholesale outlets, these revenues would likely drop considerably as the retail premium would be lost.

Another aspect not previously covered within the scope of the study is agritourism. This is an important consideration as many aquaponic farmers are able to supplement their income through educational farm tours, workshops and intensive aquaponic training. An online search using the keywords “aquaponic farm tour” brought results for several farms offering weekly tours at a price of \$10 per person with private tours being offered on demand at an average starting rate of \$80/hour. An additional search for “aquaponic training” showed results for several farms offering trainings and workshops ranging from two hours to four days in length, with prices ranging from \$30 to \$1,495 per person.

5.3 OVERALL CONCLUSIONS

Based on the results of the study, it can be concluded that aquaponic farming by use of the UVI CA2 system does offer the potential to generate profits in Arkansas. Although lettuce and basil showed high revenue potential, it's still unclear as to whether the amount of production coming from the CA2 system could effectively be sold through direct marketing only. It's likely that a combination of direct and wholesale methods would be necessary in order to properly capture market demand and maximize farm profits. As many aquaponics farms supplement income through agritourism by offering farm tours, workshops and intensive trainings, the additional revenues brought forth from this area could bring additional value to farms using aquaponics as their method of food production.

Since tilapia production was shown to generate net losses for the aquaponic component of the system, it would be advisable to investigate alternative species, such as catfish or bluegill, for aquaculture production. Another alternative might be to move away from aquaculture sales and focus solely on the hydroponic aspect of the system. In the absence of a viable market for tilapia, some aquaponic farms have forgone the sale of fish, using them solely for organic nutrient production. Taking this action would virtually eliminate the cost of fingerlings and greatly reduce feed costs, possibly resulting in a more profitable operation. It is possible, however, that this option would continue to show net losses for the system. In that case, it might be necessary to consider dropping aquaponic production altogether, in favor of a stand-alone hydroponic system.

5.4 FUTURE RESEARCH OPPORTUNITIES

Although overall results suggest that aquaponics would be feasible in Arkansas, losses seen with the production of tilapia may deem it necessary to explore other aquatic species for aquaponic production, particularly those more suited to temperate climates. Similarly, as hydroponic production showed profit potential under all scenarios, it might be interesting to compare the net revenues attainable from full aquaponic production involving the harvest of fish and vegetables to either a system harvesting only the hydroponic produce, or a stand-alone hydroponic system.

As there were no data available concerning the prices of crops sold at farmer's markets in Arkansas, it would be helpful to have a source for obtaining these data to aid local farmers in setting prices for their products at market. In addition, as lettuce and basil were shown to be profitable under the assumption that the market could handle their increased supply, a thorough market analysis of these products in Arkansas would be beneficial for farmers in terms of crop selection and the development of marketing strategies.

REFERENCES

- ACF Greenhouses. (2015). Greenhouse heater size calculator. Retrieved September 25, 2015, from <http://www.littlegreenhouse.com/heat-calc.shtml>.
- Ako, H. (2014). How to build and operate a simple small-to-large scale aquaponics system. College of Tropical Agriculture and Human Resources. Center for Tropical and Subtropical Aquaculture: 161. Retrieved September 25, 2015, from http://www.ctsa.org/files/publications/CTSA_aquaponicsHowTo.pdf
- Alcorta, M., Dufour, R., and Hinman, T. (2012). Tips for selling to wholesale buyers at terminal markets. National Center for Appropriate Technology (NCAT). IP 432, Slot 432, Version 122612. Retrieved September 25, 2015, from <https://attra.ncat.org/attra-pub/summaries/summary.php?pub=405>.
- Bailey, D.S., Rakocy, J.E., Cole, W.M., and Shultz, K.S. (1997). Economic analysis of a commercial-scale system for the production of tilapia and lettuce. Pages 603-612 in: K. Fitzsimmons, (ed.) *Tilapia Aquaculture: Proceedings from the Fourth International Symposium on Tilapia in Aquaculture*, Northeast Regional Agricultural Engineering Service, Ithaca, New York.
- BLS (Bureau of Labor Statistics). (2015). CPI Calculator. Retrieved September 25, 2015, from http://www.bls.gov/data/inflation_calculator.htm.
- Chalmers, G.A. (2004) Aquaponics and food safety. Appendix H in Savidov, N.A. 2004. Evaluation and development of aquaponics production and product market capabilities in Alberta. *Ids Initiatives Fund Final Report, Project #679056201*. Crop Diversification Centre South. Brooks, Alberta. Retrieved September 25, 2015, from <http://backyardaquaponics.com/Travis/Evaluation-and-Development-of-Aquaponics-Production-and-Product-Market-Capabilities-in-Alberta.pdf>.
- Christie, E. (2014). Water and nutrient reuse within closed hydroponic systems. *Electronic Theses and Dissertations*. Paper 1096. Retrieved September 25, 2015, from <http://digitalcommons.georgiasouthern.edu/cgi/viewcontent.cgi?article=2154&context=etd>.
- Cole, W.M., Rakocy, J.E., Shultz, K.A., and Bailey, D.S. (1997). Effects of solids removal on tilapia production and water quality in continuously aerated, outdoor tanks. Pages 373-384 in: K. Fitzsimmons, (ed.) *Tilapia Aquaculture: Proceedings from the Fourth International Symposium on Tilapia in Aquaculture*. Northeast Regional Agricultural Engineering Service, Ithaca, New York.
- Conway Locally Grown. (2015). Online market listings. Retrieved September 25, 2015, from <https://conway.locallygrown.net/market/index/3734>.
- Creswell, R.L. (2010). Unpublished manuscript. University of Florida IFAS Extension. Retrieved September 25, 2015, from <http://santarosa.ifas.ufl.edu/aquaponics-resources/>.
- Crisp, S. (2015). Telephone and email correspondence. June 24, 2015 – July 13, 2015. Aqua Cal. 2737 24th Street North, St. Petersburg, FL 33713. <http://www.aquacal.com/>.

- Denten, M. (2015). Telephone and e-mail correspondence. July 1, 2015. FarmTek. 1395 John Fitch Blvd, South Windsor, CT 06074. <http://www.farmtek.com/farm/supplies/home>.
- DLICALC (Daily Light Integral Calculator). (2015). DLICALC. University of New Hampshire Cooperative Extension. Retrieved September 25, 2015, from https://extension.unh.edu/Agric/AGGHFL/dlicalc/dlicalc_home.cfm.
- Farm Credit Mid-America. (2015). Farm real estate fixed-rate loans. Retrieved September 25, 2015, from <https://e-farmcredit.com/farm-loans/farm-real-estate-loans>.
- Galloway, R. (2015). Telephone communication. September 23, 2015. Waterveg. P.O. Box 242480, Little Rock, AR 72223. <http://www.waterveg.com/>.
- Hardesty, S., and Leff, P. (2010). Determining marketing costs and returns in alternative marketing channels. *Renewable Agriculture and Food Systems*. 25(1): 24-34. Retrieved September 25, 2015, from <http://sfp.ucdavis.edu/files/144395.pdf>.
- Hughey, T.W. (2005). Barrel-ponics (a.k.a Aquaponics in a Barrel). Retrieved September 25, 2015, from <http://www.aces.edu/dept/fisheries/education/documents/barrel-ponics.pdf>.
- Kotowich, E. (2004). Feasibility of farm direct marketing of aquaponic vegetables; Focus: Alberta approved farmers' markets. Appendix D in Savidov, N.A. 2004. Evaluation and Development of Aquaponics Production and Product Market Capabilities in *Alberta. Ids Initiatives Fund Final Report, Project #679056201*. Crop Diversification Centre South. Brooks, Alberta. Retrieved September 25, 2015, from <http://backyardaquaponics.com/Travis/Evaluation-and-Development-of-Aquaponics-Production-and-Product-Market-Capabilities-in-Alberta.pdf>.
- Lee, Y.D., and Takakura, T. (1995). Root cooling for spinach in deep hydroponic culture under high air temperature conditions. *Acta Horticulture*. Greenhouse Environment Control and Automation. Pages 121-126. Retrieved September 25, 2015, from http://www.actahort.org/books/399/399_12.htm.
- Losordo, T.M. (1997). Tilapia culture in intensive recirculating systems. Pages 185-211 in B.A. Costa-Pierce and J.E. Rakocy, (eds.) *Tilapia Aquaculture in the Americas, Volume 1*. World Aquaculture Society, Baton Rouge, Louisiana.
- Losordo, T.M., Masser, M.P., and Rakocy, J. (1998). Recirculating aquaculture tank production systems: An overview of critical considerations. Southern Regional Aquaculture Center: 451. Retrieved September 25, 2015, from <http://aqua.ucdavis.edu/DatabaseRoot/pdf/451RFS.PDF>.
- Miller, M. (2015). Telephone and email correspondence. July 23, 2015 – July 31, 2015. Hydro Royal. 5606 119th Ave SE, Ste A PMB 117, Bellevue, WA 98006. <http://www.hydroroyal.com/>.
- Morgan, L. (2013, winter). Daily light integral (DLI) and greenhouse tomato production. *The Tomato Magazine*. Pp. 10-11, 15. Retrieved September 25, 2015, from https://www.specmeters.com/assets/1/7/2013_-_DLI_Greenhouse_Tomato1.pdf.
- Nicholls, R.E. (1990). *Beginning hydroponics soilless gardening: the beginner's guide to growing vegetables, houseplants, flowers, and herbs without soil*. Running Press. Philadelphia, PA.

- NOAA NCEI (National Oceanic and Atmospheric Administration - National Centers for Environmental Information). (2015). 1981-2010 Climate normals: data files for Little Rock, Arkansas. Retrieved September 25, 2015, from <http://www.ncdc.noaa.gov/cdo-web/datatools/normals>.
- Ohio State Extension. (2011). Hydroponic crop program: hydroponic lettuce budget analysis (single bay). Retrieved September 25, 2015, from http://www.oardc.ohio-state.edu/hydroponics/t01_pageview2/Economic_Budgets.htm.
- Payscale.com. (2015). Farm manager salary (United States). Retrieved September 25, 2015, from http://www.payscale.com/research/US/Job=Farm_Manager/Salary.
- Rakocy, J.E. (1997). Integrating tilapia culture with vegetable hydroponics in recirculating systems. Pages 163-184 in B.A. Costa-Pierce and J.E. Rakocy, (eds.) *Tilapia Aquaculture in the Americas, Volume 1*. World Aquaculture Society, Baton Rouge, Louisiana.
- Rakocy, J.E., Shultz, R.C., and Bailey, D.S. (2000). Commercial aquaponics for the Caribbean. Presented at the proceedings of the 51st Gulf and Caribbean Fisheries Institute. Retrieved September 25, 2015, from http://aquaticcommons.org/13364/1/gcfi_51-27.pdf.
- Rakocy, J.E., Shultz, R.C., Bailey, D.S. and Thoman, E.S. (2004a). Aquaponic production of tilapia and basil: comparing a batch and staggered cropping system. *Acta Horticulture (ISHS)* 648:63-69. Retrieved September 25, 2015, from http://www.actahort.org/books/648/648_8.htm.
- Rakocy, J.E., Bailey, D.S., Shultz, R.C. and Thoman, E.S. (2004b). Update on tilapia and vegetable production in the UVI aquaponic system. Pages 676-690 in R.B. Bolivar, G.C. Mair, K. Fitzsimmons, Eds. *Proceedings from the Sixth International Symposium on Tilapia in Aquaculture*, Manila, Philippines. Retrieved September 25, 2015, from <http://ag.arizona.edu/azaqua/ista/ista6/ista6web/pdf/676.pdf>.
- Rakocy, J.E., Masser, M.P. and Losordo, T.M. (2006). Recirculating aquaculture tank production systems: aquaponics-integrating fish and plant culture. Southern Regional Aquaculture Center: 454. Retrieved September 25, 2015, from <http://www2.ca.uky.edu/wkrec/454fs.PDF>.
- Rakocy, J. (2012). Slides from plant production presentation at the 2012 aquaponics association meeting. Slides 30-85 in K. Semmens and M. Ferrell presentation *Commercial Aquaponics*. Retrieved September 25, 2015, from <http://aquaculture.ext.wvu.edu/r/download/151770>.
- Resh, H.M. (1995). Hydroponic food production: a definitive guidebook of soilless food growing methods. Woodbridge Press Publishing Company, Santa Barbara, California.
- Robbins, J. (2010). Starting a greenhouse business (part 1): some basic questions. University of Arkansas – Division of Agriculture. FSA6051. Retrieved September 25, 2015, from <https://www.uaex.edu/publications/pdf/FSA-6051.pdf>.
- Robison, S. and Byrne, J. (2003). Water and food sample analysis. (Letter and report. Reference: E Hutchings). Community Health – Lethbridge, October 27, 2003.

Savidov, N.A. (2004). Evaluation and development of aquaponics production and product market capabilities in Alberta. *Ids Initiatives Fund Final Report, Project #679056201*. Crop Diversification Center South, Brooks, Alberta. Retrieved September 25, 2015, from <http://backyardaquaponics.com/Travis/Evaluation-and-Development-of-Aquaponics-Production-and-Product-Market-Capabilities-in-Alberta.pdf>.

Savidov, N.A. (2005). Evaluation and development of aquaponics production and product market capabilities in Alberta. Phase II. *Ids Initiatives Fund Final Report, Project #2004-67905621*. Crop Diversification Center South, Brooks, Alberta. Retrieved September 25, 2015, from http://www.ecogrow.ca/pdf/CDC_Report_Phase_II.pdf.

Smith, A. (2015). How much does a well pump cost? KompareIt.com. Retrieved September 25, 2015, from <http://www.kompareit.com/homeandgarden/plumbing-compare-well-pump-installation-cost.html>.

Somerville, C., Cohen, M., Pantanella, E., Stankus, A. and Lovatelli, A. (2014). Small-scale aquaponic food production: integrated fish and plant farming. Food and Agriculture Organization of the United Nations, Rome. FAO Fisheries and Aquaculture Technical Paper 589. Retrieved September 25, 2015, from <http://www.fao.org/3/a-i4021e/i4021e00.pdf>.

Stringer, B. (2015). Phone correspondence. August 12, 2015. Arkansas Aquaponics. arkansasaquaponics@yahoo.com.

Thai, L., McDonald, S., Dooley, M., Kessy, L. and Rahmani, K. (2004) Marketing aquaponics produce. Appendix F in Savidov, N.A. 2004. Evaluation and Development of Aquaponics Production and Product Market Capabilities in Alberta. *Ids Initiatives Fund Final Report, Project #679056201*. Crop Diversification Centre South. Brooks, Alberta. Retrieved September 25, 2015, from <http://backyardaquaponics.com/Travis/Evaluation-and-Development-of-Aquaponics-Production-and-Product-Market-Capabilities-in-Alberta.pdf>.

Torres, A.P. and Lopez, R.G. (2010) Commercial greenhouse production: measuring daily light integral in a greenhouse. Purdue Extension. Retrieved September 25, 2015, from <https://www.extension.purdue.edu/extmedia/ho/ho-238-w.pdf>.

UK CCD (University of Kentucky Center for Crop Diversification). (2015). Farmer's market price reports for: Illinois, Kentucky and Tennessee. Retrieved September 25, 2015, from <http://www.uky.edu/Ag/CCD/price.html>.

USDA NASS (United States Department of Agriculture National Agricultural Statistics Service). (2015). Land values 2015 summary. Retrieved September 25, 2015, from <http://www.usda.gov/nass/PUBS/TODAYRPT/land0815.pdf>.

U.S. EIA (United States Energy Information Administration). (2015a). Natural gas prices: data for Arkansas. Retrieved September 25, 2015, from http://www.eia.gov/dnav/ng/ng_pri_sum_dc_u_sar_m.htm.

U.S. EIA (United States Energy Information Administration). (2015b). Average retail price of electricity: data files for Arkansas. Retrieved September 25, 2015, from

<http://www.eia.gov/electricity/data/browser/#/topic/7?agg=0,1&geo=g00000000g&endsec=vg&freq=M&start=200101&end=201506&ctype=linechart<ype=pin&rtype=s&pin=&rse=0&mptype=0>.

U.S. EIA (United States Energy Information Administration). (2015c). Arkansas weekly heating oil and propane prices. Retrieved September 25, 2015, from http://www.eia.gov/dnav/pet/hist/LeafHandler.ashx?n=PET&s=W_EPLLPA_PRS_SAR_DPG&f=W.

U.S. EIA (United States Energy Information Administration). (2015d). Gasoline and diesel fuel update. Retrieved September 25, 2015, from <http://www.eia.gov/petroleum/gasdiesel/>.

UVI (University of Virgin Islands). (2015). Aquaculture Program. Retrieved September 25, 2015, from <http://www.uvi.edu/research/agricultural-experiment-station/aquaculture-home/default.aspx>.

Valdman, J. (2015). Telephone and e-mail correspondence. July 23, 2015. Forever Flowering Greenhouses. 15386 Little Valley Road Grass Valley, CA 95949. <http://foreverflowering.net/>.

Warren, J. (2004). Review of the current market for Tilapia. Appendix G in Savidov, N.A. 2004. Evaluation and Development of Aquaponics Production and Product Market Capabilities in Alberta. *Ids Initiatives Fund Final Report, Project #679056201*. Crop Diversification Centre South. Brooks, Alberta. Retrieved September 25, 2015, from <http://backyardaquaponics.com/Travis/Evaluation-and-Development-of-Aquaponics-Production-and-Product-Market-Capabilities-in-Alberta.pdf>.

APPENDIX

Appendix 1: Capital cost of aquaculture component

| | Unit | Quantity | Cost per Unit (\$) | Total Cost (\$) | Years of Life | Annual Depreciation (\$) |
|-----------------------------|------|----------|-----------------------|--------------------|------------------|--------------------------------|
| <u>Tanks:</u> | | | | | | |
| Fish Rearing Tanks | ea. | 4 | \$ 2,062.61 | \$ 8,250.44 | 20 | \$ 412.52 |
| Cylindro-conical Clarifiers | ea. | 2 | \$ 2,131.00 | \$ 4,261.99 | 20 | \$ 213.10 |
| Rectangular Filter Tanks | ea. | 4 | \$ 551.50 | \$ 2,206.00 | 20 | \$ 110.30 |
| Rectangular Degassing Tank | ea. | 1 | \$ 551.50 | \$ 551.50 | 20 | \$ 27.58 |
| Sump | ea. | 1 | \$ 408.11 | \$ 408.11 | 20 | \$ 20.41 |
| Base Addition Tank | ea. | 1 | \$ 170.97 | \$ 170.97 | 20 | \$ 8.55 |
| Orchard Netting | ea. | 4 | \$ 68.50 | \$ 273.99 | 10 | \$ 27.40 |
| Totals: | | | | \$ 16,122.99 | | \$ 819.85 |
| <u>Plumbing:</u> | | | | | | |
| Water Meter | ea. | 1 | \$ 77.13 | \$ 77.13 | 5 | \$ 15.43 |
| Water Pump | ea. | 1 | \$ 1,398.71 | \$ 1,398.71 | 5 | \$ 279.74 |
| Float Valve (3/4" MPT) | ea. | 1 | \$ 28.57 | \$ 28.57 | 5 | \$ 5.71 |
| Female Adapter (3/4") | ea. | 3 | \$ 0.69 | \$ 2.08 | 6 | \$ 0.35 |
| Toilet Flange (3") | ea. | 2 | \$ 5.52 | \$ 11.03 | 5 | \$ 2.21 |
| Bucket (5 gallon) | ea. | 2 | \$ 5.52 | \$ 11.03 | 2 | \$ 5.52 |
| PVC Pipe (3") | ft. | 100 | \$ 4.41 | \$ 441.20 | 20 | \$ 22.06 |
| Cap (3") | ea. | 4 | \$ 5.27 | \$ 21.09 | 20 | \$ 1.05 |
| Coupling (3") | ea. | 4 | \$ 6.08 | \$ 24.31 | 20 | \$ 1.22 |
| 4 Way Cross (3") | ea. | 1 | \$ 22.32 | \$ 22.32 | 20 | \$ 1.12 |
| 90° Elbow (3") | ea. | 11 | \$ 10.68 | \$ 117.45 | 20 | \$ 5.87 |

Appendix 1: Capital cost of aquaculture component (Cont.)

| | | | | | | | | | |
|-----------------------------|-----|-----|----|-------|----|----------|----|----|--------|
| T (3") | ea. | 7 | \$ | 15.74 | \$ | 110.18 | 20 | \$ | 5.51 |
| Ball Valve (3") | ea. | 4 | \$ | 53.55 | \$ | 214.20 | 20 | \$ | 10.71 |
| Reducer Bushing (3" x 2") | ea. | 1 | \$ | 5.24 | \$ | 5.24 | 20 | \$ | 0.26 |
| PVC Pipe (4") | ft. | 80 | \$ | 4.41 | \$ | 352.96 | 20 | \$ | 17.65 |
| Cap (4") | ea. | 2 | \$ | 12.00 | \$ | 24.00 | 20 | \$ | 1.20 |
| Male Coupling (4") | ea. | 4 | \$ | 10.42 | \$ | 41.69 | 20 | \$ | 2.08 |
| Female Coupling (4") | ea. | 4 | \$ | 10.89 | \$ | 43.55 | 20 | \$ | 2.18 |
| 45° Elbow (4") | ea. | 4 | \$ | 25.05 | \$ | 100.20 | 20 | \$ | 5.01 |
| 90° Elbow (4") | ea. | 16 | \$ | 19.26 | \$ | 308.13 | 20 | \$ | 15.41 |
| PVC Pipe (2") | ft. | 120 | \$ | 4.41 | \$ | 529.44 | 20 | \$ | 26.47 |
| Cap (2") | ea. | 1 | \$ | 1.51 | \$ | 1.51 | 20 | \$ | 0.08 |
| Male Adapter (2") | ea. | 2 | \$ | 1.89 | \$ | 3.77 | 20 | \$ | 0.19 |
| Female Adapter (2") | ea. | 2 | \$ | 1.94 | \$ | 3.88 | 20 | \$ | 0.19 |
| 45° Elbow (2") | ea. | 4 | \$ | 3.45 | \$ | 13.81 | 20 | \$ | 0.69 |
| 90° Elbow (2") | ea. | 21 | \$ | 3.01 | \$ | 63.23 | 20 | \$ | 3.16 |
| T (2") | ea. | 7 | \$ | 3.64 | \$ | 25.48 | 20 | \$ | 1.27 |
| 4 Way Cross (2") | ea. | 1 | \$ | 7.26 | \$ | 7.26 | 20 | \$ | 0.36 |
| Ball Valve (2") | ea. | 7 | \$ | 14.25 | \$ | 99.76 | 20 | \$ | 4.99 |
| Slip x FNPT (2" x 1") | ea. | 4 | \$ | 3.14 | \$ | 12.57 | 20 | \$ | 0.63 |
| Reducer Bushing (2" x 1") | ea. | 6 | \$ | 2.17 | \$ | 13.04 | 20 | \$ | 0.65 |
| PVC Pipe (1") | ft. | 10 | \$ | 4.41 | \$ | 44.12 | 20 | \$ | 2.21 |
| Male Adapter (1") | ea. | 2 | \$ | 0.89 | \$ | 1.79 | 20 | \$ | 0.09 |
| Female Adapter (1") | ea. | 6 | \$ | 0.82 | \$ | 4.90 | 20 | \$ | 0.24 |
| Ball Valve (1" slip x slip) | ea. | 3 | \$ | 4.96 | \$ | 14.89 | 20 | \$ | 0.74 |
| Totals: | | | | | \$ | 4,194.53 | | \$ | 442.25 |

Appendix 1: Capital cost of aquaculture component (Cont.)

Aeration:

| | | | | | | | | | |
|--------------------------------|-----|-----|----|--------|----|----------|----|----|----------|
| Blower (2 HP) | ea. | 1 | \$ | 879.09 | \$ | 879.09 | 10 | \$ | 87.91 |
| Air Diffusers (6"x1.5") | ea. | 93 | \$ | 8.65 | \$ | 804.22 | 1 | \$ | 804.22 |
| Nipples (1/4" NPT x 3/8" barb) | ea. | 88 | \$ | 0.33 | \$ | 29.12 | 1 | \$ | 29.12 |
| Vinyl Hose (3/8" i.d.) | ea. | 4 | \$ | 27.93 | \$ | 111.71 | 1 | \$ | 111.71 |
| Poly Tube (1") | ft. | 125 | \$ | 0.50 | \$ | 62.04 | 5 | \$ | 12.41 |
| Poly Hose Adapters | ea. | 1 | \$ | 3.54 | \$ | 3.54 | 5 | \$ | 0.71 |
| Totals: | | | | | \$ | 1,889.73 | | \$ | 1,046.08 |

Labor:

| | | | | | | | | | |
|----------------------------------|------|-----|----|----------|----|----------|----|----|--------|
| Aquaponic Component Construction | unit | 0.5 | \$ | 9,133.73 | \$ | 4,566.87 | 20 | \$ | 228.34 |
| Totals: | | | | | \$ | 4,566.87 | | \$ | 228.34 |

Water Temperature and Quality Control:

| | | | | | | | | | |
|---------------------------|-----|---|----|----------|----|-----------|----|----|--------|
| Heat Pump | ea. | 2 | \$ | 4,974.00 | \$ | 9,948.00 | 15 | \$ | 663.20 |
| Water Quality Measurement | ea. | 1 | \$ | 199.00 | \$ | 199.00 | 5 | \$ | 39.80 |
| Totals: | | | | | \$ | 10,147.00 | | \$ | 703.00 |

Total Aquaculture Capital Cost:

\$ 36,921.12 ***\$ 3,239.52***

Appendix 2: Capital cost of hydroponic component

Hydroponic Component

| | Unit | Quantity | Cost per Unit (\$) | Total Cost (\$) | Years of Life | Annual Depreciation (\$) |
|-------------------------|--------|----------|-----------------------|--------------------|------------------|-----------------------------|
| <u>Tanks:</u> | | | | | | |
| Concrete Walls | each | 6 | \$ 1,103.00 | \$ 6,618.00 | 20 | \$ 330.90 |
| LDPE Liner | each | 1 | \$ 2,412.81 | \$ 2,412.81 | 10 | \$ 241.28 |
| Lumber | each | 63 | \$ 8.11 | \$ 510.74 | 10 | \$ 51.07 |
| Tapcon Screws | each | 400 | \$ 0.28 | \$ 110.30 | 10 | \$ 11.03 |
| Polystyrene Sheets | ea. | 72 | \$ 38.61 | \$ 2,779.56 | 5 | \$ 555.91 |
| Raft Template (plywood) | ea. | 1 | \$ 30.88 | \$ 30.88 | 5 | \$ 6.18 |
| Paint | gallon | 4 | \$ 24.27 | \$ 97.06 | 5 | \$ 19.41 |
| Net Pots | case | 2 | \$ 157.67 | \$ 315.35 | 1 | \$ 315.35 |
| Totals: | | | | \$ 12,874.71 | | \$ 1,531.13 |
| <u>Plumbing:</u> | | | | | | |
| PVC Pipe (6") | ft. | 120 | \$ 4.41 | \$ 529.44 | 20 | \$ 26.47 |
| Pipe Flange (6") | ea. | 12 | \$ 54.93 | \$ 659.15 | 20 | \$ 32.96 |
| 90° Elbow (6") | ea. | 18 | \$ 41.14 | \$ 740.55 | 20 | \$ 37.03 |
| T (6") | ea. | 2 | \$ 64.47 | \$ 128.94 | 20 | \$ 6.45 |
| Flexible Coupling (6") | ea. | 3 | \$ 10.72 | \$ 32.16 | 20 | \$ 1.61 |
| Cap (6") | ea. | 2 | \$ 12.08 | \$ 24.16 | 20 | \$ 1.21 |
| Totals: | | | | \$ 2,114.41 | | \$ 105.72 |
| <u>Aeration:</u> | | | | | | |
| Blower (1.5 HP) | ea. | 1 | \$ 815.12 | \$ 815.12 | 10 | \$ 81.51 |
| Air Diffusers (3"x1") | ea. | 150 | \$ 3.28 | \$ 491.39 | 1 | \$ 491.39 |

Appendix 2: Capital cost of hydroponic component (Cont.)

| | | | | | | | | | |
|--------------------------------|-----|-----|----|-------|----|----------|---|----|--------|
| Nipples (1/4" NPT x 1/4" barb) | ea. | 150 | \$ | 0.33 | \$ | 49.64 | 1 | \$ | 49.64 |
| Vinyl Hose (1/4" i.d.) | ea. | 6 | \$ | 22.75 | \$ | 136.53 | 1 | \$ | 136.53 |
| Poly Tube (1") | ft. | 600 | \$ | 0.50 | \$ | 297.81 | 5 | \$ | 59.56 |
| Poly Hose Adapters | ea. | 1 | \$ | 3.54 | \$ | 3.54 | 5 | \$ | 0.71 |
| Totals: | | | | | \$ | 1,794.02 | | \$ | 819.33 |

Labor:

| | | | | | | | | | |
|-----------------------------------|------|-----|----|----------|----|----------|----|----|--------|
| Hydroponic Component Construction | unit | 0.5 | \$ | 9,133.73 | \$ | 4,566.87 | 20 | \$ | 228.34 |
| Totals: | | | | | \$ | 4,566.87 | | \$ | 228.34 |

Greenhouse Structure, Covering and Controls:

| | | | | | | | | | |
|---|-----|---|----|------------|----|------------|----|----|----------|
| Farm Tek Series 1000 Greenhouse 42' x 156' | ea. | 1 | \$ | 41,465.00 | \$ | 41,465.00 | 20 | \$ | 2,073.25 |
| Relay Contactor Panel iGrow pre-wired | ea. | 1 | \$ | 3,666.00 | \$ | 3,666.00 | 15 | \$ | 244.40 |
| Installation and Set-up | ea. | 1 | \$ | 110,384.00 | \$ | 110,384.00 | 20 | \$ | 5,519.20 |
| Totals: | | | | | \$ | 155,515.00 | | \$ | 7,836.85 |

Air Heating, Cooling and Circulation:

| | | | | | | | | | |
|-------------------------------------|-----|---|----|----------|----|----------|----|----|--------|
| 48" ValueTek Slant Wall Exhaust Fan | ea. | 4 | \$ | 799.00 | \$ | 3,196.00 | 15 | \$ | 213.07 |
| 20" ValueTek Horizontal Airflow Fan | ea. | 6 | \$ | 144.95 | \$ | 869.70 | 15 | \$ | 57.98 |
| Evaporative Cooler 40' x 6' | ea. | 1 | \$ | 3,818.75 | \$ | 3,818.75 | 6 | \$ | 636.46 |
| Rigid Power Pad Vent 40' x 6' | ea. | 1 | \$ | 3,395.00 | \$ | 3,395.00 | 15 | \$ | 226.33 |
| Propane Heater 160,000BTU | ea. | 2 | \$ | 1,229.00 | \$ | 2,458.00 | 15 | \$ | 163.87 |

Appendix 2: Capital cost of hydroponic component (Cont.)

| | | | | | | |
|--|-----|----|--------------|----------------------------|----|----------------------------|
| Interior Shade | ea. | 1 | \$ 14,706.38 | <u>\$ 14,706.38</u> | 12 | <u>\$ 1,225.53</u> |
| Totals: | | | | <u>\$ 28,443.83</u> | | <u>\$ 2,523.24</u> |
| <u>Supplemental Lighting:</u> | | | | | | |
| 1000W Metal Halide Light Fixture and Bulb | ea. | 27 | \$ 299.95 | \$ 8,098.65 | 15 | \$ 539.91 |
| Light Intensity Measurement Equipment | ea. | 1 | \$ 325.00 | <u>\$ 325.00</u> | 5 | <u>\$ 65.00</u> |
| Totals: | | | | <u>\$ 8,423.65</u> | | <u>\$ 604.91</u> |
| <i>Total Hydroponic Capital Cost:</i> | | | | <u><u>\$213,732.48</u></u> | | <u><u>\$ 13,649.53</u></u> |

Appendix 3: Monthly energy costs for Arkansas:

| Month: | Natural Gas (\$/1000cu.ft.) | Biomass (\$/ton) | Electricity (cents/kWh) | Propane (\$/gal) |
|------------------|------------------------------------|-------------------------|--------------------------------|-------------------------|
| January | \$ 8.83 | \$ 300.00 | \$ 7.54 | \$ 2.24 |
| February | \$ 8.36 | \$ 300.00 | \$ 7.74 | \$ 2.20 |
| March | \$ 7.87 | \$ 300.00 | \$ 7.69 | \$ 2.20 |
| April | \$ 7.72 | \$ 300.00 | \$ 7.83 | - |
| May | \$ 7.85 | \$ 300.00 | \$ 7.87 | - |
| June | \$ 8.16 | \$ 300.00 | \$ 8.22 | - |
| July | \$ 9.41 | \$ 300.00 | \$ 8.45 | - |
| August | \$ 9.43 | \$ 300.00 | \$ 8.33 | - |
| September | \$ 9.04 | \$ 300.00 | \$ 8.34 | - |
| October | \$ 8.35 | \$ 300.00 | \$ 7.71 | \$ 2.24 |
| November | \$ 8.47 | \$ 300.00 | \$ 7.67 | \$ 2.29 |
| December | \$ 8.24 | \$ 300.00 | \$ 7.57 | \$ 2.28 |

Appendix 4: Calculation of DLI change in double-polyethylene greenhouse

| Indiana Daily Light Integral | | | | | | | |
|------------------------------|-------|----------|---|----|-----|----------------|---------|
| Month | DLI | Ave. DLI | DLI In Greenhouse with Double Poly Sheeting | | | Average GH DLI | % Diff. |
| Jan | 10-15 | 12.5 | - | 8 | 7.5 | 8 | -38% |
| Feb | 15-20 | 17.5 | 10 | 12 | 18 | 13 | -24% |
| March | 25-30 | 27.5 | 15 | 15 | 22 | 17 | -37% |
| April | 30-35 | 32.5 | 24 | 17 | - | 21 | -37% |
| May | 40-45 | 42.5 | 25 | 21 | - | 23 | -46% |
| June | 40-50 | 42.5 | 28 | 25 | - | 27 | -38% |
| July | 40-45 | 42.5 | 30 | 30 | - | 30 | -29% |
| Aug | 40-45 | 42.5 | 28 | 28 | - | 28 | -34% |
| Sept | 35-40 | 37.5 | 21 | 18 | - | 20 | -48% |
| Oct | 20-25 | 22.5 | 13 | 14 | - | 14 | -40% |
| Nov | 10-15 | 12.5 | 10 | 8 | - | 9 | -28% |
| Dec | 10-15 | 12.5 | 8 | 7 | - | 8 | -40% |

Appendix 5: Greenhouse BTU calculation

| Area of Structure (sq.ft.): | Heat Loss Value (1/R-value): | Ave AR Air Temp (Jan-Dec): | BTU Need @ 50: | BTU Need @ 55: | BTU Need @ 60: | BTU Need @ 65: | BTU Need @ 70: | BTU Need @ 75: |
|------------------------------------|-------------------------------------|-----------------------------------|-----------------------|-----------------------|-----------------------|-----------------------|-----------------------|-----------------------|
| 11800 | 0.7 | 40.8 | 75,992 | 117,292 | 158,592 | 199,892 | 241,192 | 282,492 |
| | | 44.8 | 42,952 | 84,252 | 125,552 | 166,852 | 208,152 | 249,452 |
| | | 53.4 | (28,084) | 13,216 | 54,516 | 95,816 | 137,116 | 178,416 |
| | | 62.1 | (99,946) | (58,646) | (17,346) | 23,954 | 65,254 | 106,554 |
| | | 71.1 | (174,286) | (132,986) | (91,686) | (50,386) | (9,086) | 32,214 |
| | | 79.1 | (240,366) | (199,066) | (157,766) | (116,466) | (75,166) | (33,866) |
| | | 82.8 | (270,928) | (229,628) | (188,328) | (147,028) | (105,728) | (64,428) |
| | | 82.5 | (268,450) | (227,150) | (185,850) | (144,550) | (103,250) | (61,950) |
| | | 75.0 | (206,500) | (165,200) | (123,900) | (82,600) | (41,300) | - |
| | | 63.7 | (113,162) | (71,862) | (30,562) | 10,738 | 52,038 | 93,338 |
| | | 52.6 | (21,476) | 19,824 | 61,124 | 102,424 | 143,724 | 185,024 |
| | | 43.0 | 57,820 | 99,120 | 140,420 | 181,720 | 223,020 | 264,320 |
| | | 20 | 247,800 | 289,100 | 330,400 | 371,700 | 413,000 | 454,300 |
| | | 10 | 330,400 | 371,700 | 413,000 | 454,300 | 495,600 | 536,900 |

Appendix 6: Heating cost calculation

| Annual Air Heating Cost Using Natural Gas Heaters | | | | | | | | | |
|--|-----------------|-----------------------------------|----------------------------------|-------------------------|--|--------------------------------|---|-----------------|--------------------|
| Month | Ave Temp | BTU's Needed for Air @ 55F | BTU's from Supp. Lighting | Net BTU's Needed | Natural Gas Needed (cubic ft./hr) | 1000's of cubic ft./day | AR Nat. Gas Prices (\$/1000 cubic ft.) | Cost/Day | Cost/Month |
| Jan | 40.8 | 117,292 | 5,336 | 111,956 | 106.63 | 2.56 | 8.83 | \$ 22.60 | \$ 677.88 |
| Feb | 44.8 | 84,252 | - | 84,252 | 80.24 | 1.93 | 8.36 | \$ 16.10 | \$ 482.98 |
| Mar | 53.4 | 13,216 | - | 13,216 | 12.59 | 0.30 | 7.87 | \$ 2.38 | \$ 71.32 |
| Apr | 62.1 | (58,646) | - | | 0.00 | 0.00 | 7.72 | \$ - | \$ - |
| May | 71.1 | (132,986) | - | | 0.00 | 0.00 | 8.75 | \$ - | \$ - |
| Jun | 79.1 | (199,066) | - | | 0.00 | 0.00 | 9.2 | \$ - | \$ - |
| Jul | 82.8 | (229,628) | - | | 0.00 | 0.00 | 9.41 | \$ - | \$ - |
| Aug | 82.5 | (227,150) | - | | 0.00 | 0.00 | 9.43 | \$ - | \$ - |
| Sep | 75 | (165,200) | - | | 0.00 | 0.00 | 9.04 | \$ - | \$ - |
| Oct | 63.7 | (71,862) | - | | 0.00 | 0.00 | 8.35 | \$ - | \$ - |
| Nov | 52.6 | 19,824 | 3,186 | 16,638 | 15.85 | 0.38 | 8.47 | \$ 3.22 | \$ 96.63 |
| Dec | 43 | 99,120 | 6,410 | 92,710 | 88.29 | 2.12 | 8.24 | \$ 17.46 | \$ 523.84 |
| | | | | | | | | | \$ 1,852.65 |

Appendix 7: Monthly utility cost for environmental control

| <u>Month</u> | <u>Water Heating/Cooling</u> | <u>Air Heating</u> | <u>Air Cooling</u> | <u>Air Circulation</u> | <u>Supplemental Lighting</u> | <u>System Total</u> |
|--------------|------------------------------|--------------------|--------------------|------------------------|------------------------------|---------------------|
| January | \$ 172.50 | \$ 677.88 | \$ - | \$ 77.41 | \$ 87.72 | \$ 1,015.52 |
| February | \$ 177.08 | \$ 482.98 | \$ - | \$ 79.47 | \$ - | \$ 739.52 |
| March | \$ 175.93 | \$ 71.32 | \$ - | \$ 78.95 | \$ - | \$ 326.21 |
| April | \$ 179.13 | \$ - | \$ - | \$ 80.39 | \$ - | \$ 259.53 |
| May | \$ 180.05 | \$ - | \$ 89.78 | \$ 53.87 | \$ - | \$ 323.70 |
| June | \$ 188.06 | \$ - | \$ 187.55 | \$ 28.13 | \$ - | \$ 403.74 |
| July | \$ 193.32 | \$ - | \$ 192.80 | \$ 28.92 | \$ - | \$ 415.03 |
| August | \$ 190.57 | \$ - | \$ 190.06 | \$ 28.51 | \$ - | \$ 409.14 |
| September | \$ 190.80 | \$ - | \$ 95.14 | \$ 57.09 | \$ - | \$ 343.03 |
| October | \$ 176.39 | \$ - | \$ - | \$ 79.16 | \$ - | \$ 255.55 |
| November | \$ 175.47 | \$ 96.63 | \$ - | \$ 78.75 | \$ 53.28 | \$ 404.14 |
| December | \$ 173.19 | \$ 523.84 | \$ - | \$ 7.72 | \$ 105.81 | \$ 880.56 |
| Total | \$ 2,172.49 | \$ 1,852.65 | \$ 755.32 | \$ 748.38 | \$ 246.82 | \$ 5,775.67 |