Masters Theses

Student Theses and Dissertations

2007

Applications of solar energy to power stand-alone area and street lighting

Joshua David Bollinger

Follow this and additional works at: https://scholarsmine.mst.edu/masters_theses



Part of the [Electrical and Computer Engineering Commons](#)

Department:

Recommended Citation

Bollinger, Joshua David, "Applications of solar energy to power stand-alone area and street lighting" (2007). *Masters Theses*. 5506.

https://scholarsmine.mst.edu/masters_theses/5506

This thesis is brought to you by Scholars' Mine, a service of the Missouri S&T Library and Learning Resources. This work is protected by U. S. Copyright Law. Unauthorized use including reproduction for redistribution requires the permission of the copyright holder. For more information, please contact scholarsmine@mst.edu.

APPLICATIONS OF SOLAR ENERGY TO POWER STAND-ALONE AREA AND
STREET LIGHTING

by

JOSHUA DAVID BOLLINGER

A THESIS

Presented to the Faculty of the Graduate School of the

UNIVERSITY OF MISSOURI-ROLLA

In Partial Fulfillment of the Requirements for the Degree

MASTER OF SCIENCE IN ELECTRICAL ENGINEERING

2007

Approved by

Badrul Chowdhury, Advisor

Keith Corzine

Mehdi Ferdowsi

ABSTRACT

A stand-alone solar-powered street or area lighting system is designed and operated completely independent of the power grid. The equipment and maintenance costs associated with a stand-alone solar-powered system are compared with the cost of using electricity to run grid connected street lights. The project focused on the viability of using solar energy to power the lights in the area surrounding St. Louis, Missouri. The results had to be consistent to warrant converting new areas to independent solar powered lighting. A prototype system is constructed from equipment available on the market for the purpose of gathering data on different lighting sources. The prototype uses a 100W high pressure sodium lamp, 165W solar panel, a maximum power point tracker, an inverter, and lead acid gel batteries. The system has the design capability to last for four days of overcast skies and generate around 9500 lumens of brightness. The results are used to determine the size of the panel and the number of batteries required to guarantee that the lamp would work a preset number of days without failure. Real-life data collected by the prototype system and verified by computer simulations were used to evaluate the long-term performance of the system. An economic analysis is also performed to determine if the project is cost effective.

ACKNOWLEDGMENTS

I would like to thank Dr. Chowdhury for providing me with the opportunity to study the different forms of renewable energy. The difficulties of designing and building the project would have been far more difficult without your persistent drive for excellence. The guidance during the long and sometimes difficult parts of the project provided a learning curve that allowed me to gain confidence and a strong background to fall back on. The work on this project has only strengthened my desire to incorporate all forms of renewable energy and to look at new technologies that promote a cleaner environment. The study of solar energy was what got me into the field of Electrical Engineering. To Dr. Corzine, the advice you have given me over the last two year was invaluable in helping me make it to this point in my life. During the design phase, you helped me to select the key pieces of equipment that were implemented into the prototype design. To Dr. Ferdowsi, the lessons learned from your courses provided a background that made understanding the equipment easier and provided a background to expand my perception on DC systems.

To Ameren UE, I thank you greatly for providing the funding necessary to build a solar powered project. The confidence you instilled in me to move the project past the conventional street lights to the new LED light, provided a glimpse of the future and presented an opportunity to use developing technologies.

To my fellow students; James Jenkins, Ryan Salisbury, and Nathan Publow thank you for your assistance on this project. To James and Ryan, I thank you for implementing my design and assembling the prototype system. To Nathan, I thank you for your efforts on the Hybrid2 simulator and suggestions. Without you guys, the project would not have gone as smoothly as it did.

To my Mother and Father, I especially want to thank them for persuading me to do my Master's while I was young and for putting me through school to get my Bachelors. To my Brother, thanks for listening when things weren't going well and for being there when this town felt more like a prison and getting me out to the golf course.

TABLE OF CONTENTS

	Page
ABSTRACT.....	iii
ACKNOWLEDGMENTS	iv
LIST OF ILLUSTRATIONS.....	viii
LIST OF TABLES.....	x
SECTION	
1. INTRODUCTION.....	1
1.1. PAST STAND-ALONE RESEARCH STUDIES.	1
1.2. FUTURE STAND-ALONE APPLICATIONS.	2
2. BASICS OF RENEWABLE ENERGY	4
2.1. AREAS OF THE WORLD USING RENEWABLE ENERGY.....	4
2.2. FOUR MAIN RENEWABLE ENERGY FORMS.....	5
2.2.1. Wind Energy.....	5
2.2.2. Geothermal	7
2.2.3. Hydroelectric	7
2.2.4. Solar Photovoltaics.....	8
2.3. WEATHER AND SOLAR ENERGY	9
2.4. APPLICATIONS OF SOLAR PHOTOVOLTAIC	14
2.4.1. Grid vs. Off-Grid.....	14
2.4.2. Hybrid Systems	16
2.4.3. Stand-Alone Systems	16
3. BASICS OF PHOTOVOLTAIC PANELS.....	18
3.1. PHYSICAL MAKEUP	18
3.1.1. Energy Collection.....	18
3.1.2. Internal Characteristics.....	18
3.1.3. Photovoltaic Material Types	19
3.2. HARNESSING THE SUN'S ENERGY	20
4. PROJECT DESCRIPTION	21
4.1. DESIGN CONSIDERATIONS	21

4.2. PROTOTYPE DESIGN.....	21
4.3. PROJECT EQUIPMENT.....	22
4.3.1. The Photovoltaic Panel.....	22
4.3.2. The Maximum Power Point Tracker.....	23
4.3.3. The Inverter.....	25
4.3.4. The Batteries.....	26
4.4. TYPES OF LIGHTING.....	28
4.4.1. High Pressure Sodium Lamp.....	29
4.4.2. Low Pressure Sodium Lamp.....	30
4.4.3. Fluorescent Lamps.....	30
4.4.4. Light Emitting Diode.....	31
5. PROTOTYPE PHOTOVOLTAIC STAND-ALONE SYSTEM RESULTS.....	33
5.1. PARAMETERS OF THE SYSTEM TEST.....	33
5.2. RECORDING EQUIPMENT.....	33
5.2.1. Handheld Recorder.....	34
5.2.2. Data Recorder.....	36
5.3. LIGHTING LOADS.....	39
5.3.1. High Pressure Sodium Lamp.....	39
5.3.1.1. Test one.....	39
5.3.1.2. Test two.....	45
5.3.2. Test with the Light Emitting Diode.....	48
5.3.3. Test with Fluorescent Lighting.....	49
5.3.4. Secondary Test.....	51
6. PROJECT SIMULATIONS.....	53
6.1. SIMULATION PROGRAM.....	53
6.1.1. Hybrid2.....	53
6.1.2. Solar Insolation and Temperature Values.....	53
6.1.3. Simulation Standards.....	55
6.2. HYBRID2 OUTPUT ANALYSIS.....	56
6.3. HYBRID2 TEST RESULTS.....	58
6.3.1. Simulations with High Pressure Sodium Lamp.....	58

6.3.2. Simulation with Low Pressure Sodium Lamp.....	61
6.3.3. LED Light Simulation.....	62
6.3.4. Other Test Considerations.....	63
7. ECONOMIC ANALYSIS.....	66
7.1. DESIGN CONSIDERATIONS AND COST ANALYSIS.....	66
7.2. ECONOMIC ANALYSIS OF THE VARIOUS LIGHTING SYSTEMS.....	69
7.2.1. The HPS Prototype System.....	69
7.2.2. The LED System.....	70
8. CONCLUSION.....	72
APPENDICES	
A. EXPANDED REAL TIME RESULTS.....	75
B. HYBRID2 INPUT AND OUTPUT POWER GRAPHS.....	81
C. SOLAR PANEL SIZING SHEET.....	84
D. LED LAMP OUTPUT LIGHTING.....	86
BIBLIOGRAPHY.....	88
VITA.....	92

LIST OF ILLUSTRATIONS

Figure	Page
2.1. Annual Wind Power Resources and Wind Power Classes	6
2.2. Voltage and Temperature Variations of a Photovoltaic Cell	10
2.3. Output Power and the Effects of Temperature	10
2.4. Solar Insolation Values for the United States	11
2.5. Panel Covered in Ice at the Start of the Storm.....	12
2.6. Solar Panel after Ice Melted Off, the Day after the Storm.....	13
2.7. Two-Inch-Thick Ice on Battery and the Controller Containers	14
2.8. Grid Connection Equipment and Layout	15
2.9. Hybrid System Equipment and Layout.....	16
3.1. Solar Panel Equivalent Circuit.....	19
3.2. Photovoltaic Cells Connected in Series	20
4.1. The Prototype System Layout.....	22
4.2. The SunSaver 20 Maximum Power Point Tracker	24
4.3. The Power Bright 900W Inverter	26
4.4. The Rolls Surette HT-8D Battery	27
4.5. The 100W High Pressure Sodium Lamp	29
4.6. Light Emitting Diode Street Lamp in Operation, February 2007	31
5.1. Fluke Probe Current Measurement Hours after HPS Startup	34
5.2. Fluke Probe Current Measurement at Sundown on Nov. 17, 2006	35
5.3. Fluke Probe Current Measurement before Sunrise on Nov. 18, 2006.	35
5.4. Fluke Probe Measurement on the AC Side of the LED Lamp	36
5.5. HPS Test One, Battery Values on December 2, 2006	40
5.6. Battery Voltage on December 2, 2006.....	40
5.7. Battery Wattage with Calculated Nighttime Values on December 2, 2006	41
5.8. Input Power to the Batteries on December 2, 2006	42
5.9. Calculated DC Current from the Batteries to the Load on December 2, 2006	43
5.10. Battery Values on a Mostly Cloudy Day in November 28, 2006	44

5.11. Solar Panel Voltage and Currents on December 2, 2006.....	44
5.12. HPS Test, Panel Output the Week of December 11-18, 2006.....	45
5.13. Battery Voltage and Current Measurements during December 11-18, 2006.....	46
5.14. Second HPS Test Panel Values in January 9–16, 2007.....	47
5.15. The HPS Lamp in Operation.....	47
5.16. LED Test Results of the Panel, Two Consecutive Days of Overcast Skies.....	48
5.17. LED Test, Battery Results Show Lamp Operating during Overcast Period.....	49
5.18. Fluorescent Light Test Results on Load Side on February 13-17, 2007.....	50
5.19. Effect Fluorescent Light had on the Batteries' Ability to Recharge.....	51
5.20. Timer Test on February 6, 2007 with 3 Hours Down Time for HPS Lamp.....	52
6.1. Photovoltaic Values for a GE 165W Panel.....	54
6.2. Solar Insolation Values for St. Louis in December 1989.....	55
6.3. Weeklong Simulation Showing the Primary AC Load, and Unmet Load.....	56
6.4. LED Test, Energy Stored In and Out of the Batteries in kW.....	57
6.5. Battery Energy Reserves of Prototype System, September to October 1990.....	59
6.6. Battery Storage Simulation using a 130W HPS Lamp, September to October.....	60
6.7. Best Scenario for the High-Efficiency HPS Lamp, Ah/Time.....	60
6.8. LPS with 200W Solar Panel Simulated from September to December 1990.....	61
6.9. Best-Case Scenario for LPS Lamp from September to December 1990.....	62
6.10. Battery Energy Reserves for LED in Ah/Time.....	63
6.11. High-Efficiency HPS Lamp in Phoenix for 31 days in December 1989.....	64
6.12. Low Pressure Sodium Lamp in Phoenix in December 1989.....	65
8.1. The Low-Efficiency HPS lamp during 4 Sunny Days on January 23-26, 2007.....	72

LIST OF TABLES

Table	Page
4.1. GE 165W Solar Panel Values	23
4.2. Level of Discharge and Battery Longevity of Rolls Surette HT-8D	28
5.1. Daytime Measurements of the 165W Solar Panel on November 20, 2006	37
5.2. Nighttime Measurements of the HPS on November 19, 2006.....	38
5.3. Calculated Battery Currents on December 2, 2006	42
7.1. The Original Parts List.....	67
7.2. The Prototype System Parts List.....	68
7.3. The LPS Prototype System with Calculated Equipment	68
7.4. Cost of HPS Prototype System	70
7.5. Cost of LED Prototype System.....	71
8.1. Breakdown of the Test Results	74

1. INTRODUCTION

The main focus of this project is to determine the options that are available to replace grid-powered street lamps with a stand-alone system that has the reliability to work under the worst conditions. The renewable energy source selected for this project is a solar photovoltaic panel. The study was undertaken to determine the capabilities of a stand-alone systems and to determine if the long-term saving of electricity warrants the conversion to new lamps built off the power grid. The development of the world's power infrastructure involves expanding the use of renewable energy in combination with the existing power generators. The viability of solar energy in St. Louis is determined by weather conditions and the amount of solar insolation that the area received throughout the year. Heavy consideration to the localized conditions during the winter has the strongest impact on determining the feasibility of using solar energy in the midwestern United States.

The size of the photovoltaic system is dependent on the size of the load and availability of sunlight in the winter months. A prototype system was built to understand how the system would react under the changing weather conditions and solar insolation values. The system was designed to power the load and to be cost effective. The initial cost of the prototype system equipment for each lamp is to be considered against the cost of grid connected street lamps. The lowest overall cost would be used on future street lighting applications. A comparison will be made between commercially available stand-alone systems against the purchasing of individual parts for the prototype system. The load is a 100W high pressure sodium lamp, to match the standard lighting applications for side streets.

1.1. PAST STAND-ALONE RESEARCH STUDIES

Past studies provided an increased level of understanding of how solar energy is utilized around the world, and how this project fits with the application of stand-alone street lighting. The idea of using solar energy to power a street light began in the '90s as

a solution to the cost of operating street lights throughout the year. The design of the early systems incorporated a lamp load of less than 50W, and was used primarily for lighting paths or walkways. The majority of systems studied have used lamps of either the low pressure sodium lamp or the fluorescent lamp variety. The common areas where case studies have been done on the viability of powering street lights with solar energy were done in regions of high amounts of solar insolation. These areas include New Mexico, California, Thailand, and Spain.

One of the earliest studies was conducted by the Parks and Recreation Department of Albuquerque, New Mexico [1]. The design of the system used two 50W photovoltaic panels with a 35W low pressure sodium lamp [1]. The stand-alone systems were designed to last for six hours a night and used a boost converter due to the design of a working maximum power point tracker was still in the development stage. The results of the study showed the potential of using solar energy to power street lights, and built the groundwork for future designs [1]. Isolated parts of the world are ideal places to study the abilities of stand-alone lighting systems due to the lack of electricity to those regions. The test done in Thailand used a basic photovoltaic system that worked seven hours a day and established how different types of lamps worked in the remote villages [2]. The categories that were instrumental in determining between the low pressure sodium (LPS), the high pressure sodium (HPS), and the fluorescent light were the lifespan of the bulb, cost, light output in lumens, wattage, and color rendering [2]. The fluorescent lamp was selected due to its lower cost and the adequate production of light. This study conveyed the problems that affect the design of the system, due to the availability and cost of replacement parts. The HPS lamp worked more effectively than the other two lamps in the test, but cost seven times more than the fluorescent lamp [2]. The LPS lamp cost more than the HPS and was difficult to purchase in Thailand [2].

1.2. FUTURE STAND-ALONE APPLICATIONS

The future of stand-alone street lighting applications will be determined by improvements in equipment effectiveness and the advancement of new technologies. The studies that incorporated light emitting diodes (LED) and HPS lamps detail the

advancements made towards the implementation of solar energy to light highways. The large amounts of power required to operate the high pressure sodium lamp entail the use of large solar arrays and a battery bank to handle overcast days. To decrease the power demand without changing the bulb required incorporating high-efficiency ballast [3]. The HPS lamp requires a high frequency electronic ballast to operate with the efficiency of the lamp depending on the ignition and acoustic resonance disturbances [4]. The implementation of high-efficiency HPS lamps into current designs increases the cost of the stand-alone system, but also increases the number of days the light would last. The best way to limit the increased cost comes in the design stage, when the selection of the other equipment is determined. To supplement the rising cost of the improved lamp, the cost of solar panels decreases with the lower wattage ratings. Efficiency of the MPPT is another option that would increase the performance of any stand-alone system. Improving the duty ratio and the algorithms that control the real power from the solar panel reduces the energy lost to heat [5]. The newest form of street lighting that shows promise is the LED. The studies conducted in California analyzed the application of LED lamps in comparison with the other forms of street lighting. The study in San Diego looked at the LED as a solution to the high cost of running the HPS lights [6]. The results show the new technology produced too little light to be used on city streets, but would lead to further interest in future applications of the light.

The analysis of the studies presents a strong argument that with the advancements in equipment and design, the likelihood of implementing stand-alone street lighting will improve. The wide-spread replacement power grid lighting with stand-alone lighting hinges on cost and reliability. When studies prove a system design provides consistent lighting and would pay for itself in five to ten years, the idea moves from being a novelty item to small-scale utilization.

2. BASICS OF RENEWABLE ENERGY

As the fears of climate change increase, the demands for devices that generate electricity that are environmentally friendly will steadily increase. Most of the electric power generated in the world comes from the burning of fossil fuels to generate a consistent supply of energy. Every year, the demand for electricity increases, pushing the current power plants and power distribution grids to their limits. To meet this growing need, more fossil fuel power plants are being constructed, thus increasing the pollutants dispensed into the environment. The need to develop clean energy-producing systems that can perform as reliably as fossil fuel plants must be implemented throughout the world in order to decrease the effects man has on the planet. In order for a renewable energy source to be added to a power utility, the three conditions to be met are reliability, cost, and lifespan. Due to the high initial cost of building a renewable power source and a slower rate of return than fossil fuel plants, progress has been slow in the construction of renewable energy plants outside of wind power plants [7]. The design of this project focuses on using a renewable-energy-based stand-alone system to decrease the energy usage at times of low power consumption and promotes the use of an environmentally-friendly energy resource. There are many forms of renewable energy resources that are currently available for integration into the power grid; the top four energy sources are wind, sun, water, and geothermal.

2.1. AREAS OF THE WORLD USING RENEWABLE ENERGY

Geography plays an integral role in determining what forms of renewable energy will be the most useful. Hydroelectric energy is the primary source of electricity for the countries of Canada and Brazil [8]. Denmark, Germany, and the United States are increasing the number of wind turbines and offshore wind farms to meet the increasing energy demands [7]. Other European nations are moving towards a renewable energy stance with increased photovoltaic and wind energy projects that will make up a large portion of their future infrastructure [7]. Australia, Japan, and third world African

countries use solar energy in isolated regions and cities to harness the sun's energy [9]. In the United States, the use of wind energy centers around the west coast and small-to-large wind farms scattered across the nation. The Southwest United States benefits from abundant sunlight and moderate weather during the winter. The Midwest is not known for employing renewable energy due to the lower cost of producing power from coal plants. Also, the conditions of the land makes implementing hydroelectric dams difficult, the lack of mountain ranges and water sources reduce the average speed of the wind, and the high percentage of clouds in the winter hampers the use of solar panels. The implementation of wind power and solar energy has come from individual home owners that accept the cost involved and the number of consumers will continue to increase with a reduction in equipment cost and utility rate hikes.

2.2. FOUR MAIN RENEWABLE ENERGY FORMS

The main types of renewable energy are wind energy, solar photovoltaic, hydroelectric, and geothermal. Every year, the demand for electricity grows. To meet this increased demand, countries have to decide what form of generation will provide reliable power that will fulfill the future needs of the people. The public demand for the integration of renewable energy grows with every study on climate change. Fossil fuel power plants deliver the necessary electricity that can be raised or lowered to meet the demand, but produce byproducts that are harmful to the environment. The oldest forms of renewable energy that harness the power of nature are wind turbines and hydroelectric power plants. Both forms have been used for hundreds of years to improve the quality of life for the people by using machines powered by nature. Photovoltaic energy has only been around a few decades, and came about through advancements in the space program. The performances of the individual cells of a solar panel are steadily improving with newer advancements with semiconductor material.

2.2.1. Wind Energy. Converting the movement of air into electricity is the fastest growing supplier of renewable energy in Europe [7]. Wind farms produce massive amounts of power that provide an environmentally-friendly option to counteract the growing need for more fossil fuel plants. The drawbacks that hinder the expansion of

wind turbines are the distance from turbines to the power grid, startup cost, inconsistency of wind speed, and visual aesthetics. Areas in the U.S. that generate the most air flow are in remote locations that require running power lines hundreds of miles to reach the power grid from wind farms located 10 kilometers from shore, in isolated locations surrounded by farm land, and at the edges of mountain ranges [10]. The slope of mountain ranges produces higher wind speeds than any coast line, as shown in Figure 2.1.

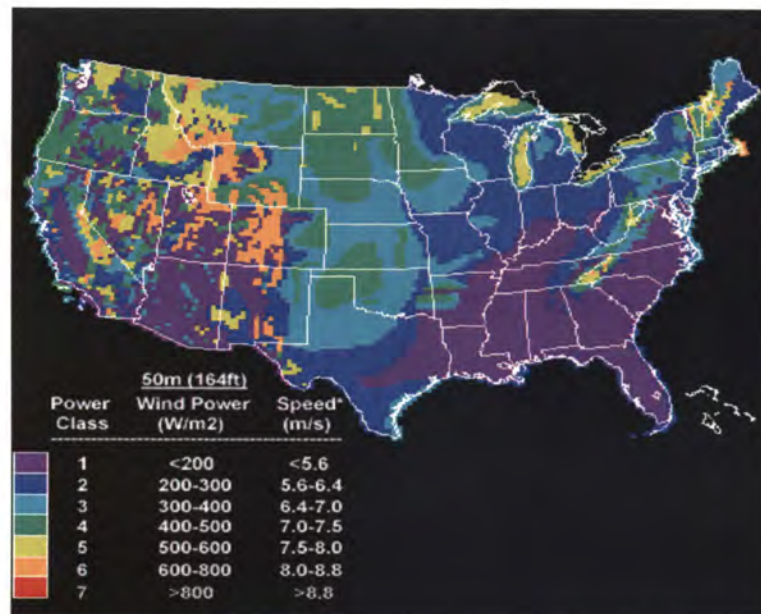

Figure 2.1. Annual Wind Power Resources and Wind Power Classes [11]

Figure 2.1 demonstrates that most of the regions capable of producing sustainable air flow are located far from large urban centers. The Northeast and the West coast of the United States produce the air speeds capable of providing adequate air flow to generate continuous electricity from offshore wind farms. The shore lines that work well for wind generation are located in areas where people perceive the wind turbines as obstructions that are visually intrusive and spoil the natural beauty that draws tourists. For wind energy to become a practical energy source that can meet the demands of the public, the issue of reliability must be resolved to meet the varying loads that occur throughout the day.

2.2.2. Geothermal. One of the largest-producing sources of renewable energy in the world is geothermal. All other forms of renewable energy in one form or another harness their energy from the sun; geothermal plants harness the energy of the planet [12]. The formation of magma below the surface of the Earth provides energy that is harvested to produce power. Geothermal power plants generate electricity through means of capturing hot water or steam from the ground, which drives a turbine [13]. The combined output of solar and wind energy make up less than half the power produced using geothermal energy [13]. Compared with wind and solar energy, the cost per kilowatt hour is much less for geothermal; in some regions, the cost of fossil fuel plants are higher [12]. The Southwest generates the majority of the geothermal capabilities of the United States. The Philippines, El Salvador, Nicaragua, and Iceland have the highest percentages for incorporating geothermal energy into their power generation capabilities [12]. The advantage of geothermal energy is that the fuel source is constant and produces little in the way of harmful byproducts. The energy harnessed is naturally produced by the planet, but the lifespan for power generation is dependant on the time period it takes for the magma to cool ranging from five thousand to one million years [13]. The main drawback of geothermal power is that the output gases in confined spaces are hazardous and there is potential for ground subsidence [13].

2.2.3. Hydroelectric. Harnessing the power of water is the oldest form of renewable energy. Hydroelectric power provides a fifth of the world's electricity and is the main source of power for dozens of countries around the world [14]. The generation equipment in a hydroelectric plant is similar to plants that burn fossil fuels to produce steam for powering their generators. The conversion of water to steam in a coal plant produces byproducts that pollute the environment. Hydroelectric plants harness the kinetic energy of flowing water instead of steam to spin the generator turbines.

There are multiple ways to harness the power of water, such as building dams or altering the flow of a river. The largest power producers are dams, which block the flow of a river to store millions of gallons of water to create an endless supply of fuel for the generators. A dam works on the principle of water pressure; the higher the water level, the farther the water will fall. The water gains speed from gravity and, in turn, pass the energy off to the rotor that spins the turbine to generate power. In regions incapable of

building a dam, the next hydroelectric power plant harnesses the kinetic energy of a fast-moving river by diverting the water through a tunnel to spin the turbine shaft [14]. This form is less reliable than a dam due to fluctuations in river levels, but has a lower startup cost and does not block passage of the river. The form of is similar to a dam, except that the water is pumped into the basin. During off-peak hours, the water is pumped from a river or lake to the holding reservoir to be used during hours of high demand [14]. The main benefits of using hydroelectric facilities is the ability of the plant to increase or decrease the power output fairly quickly, minuscule fuel cost, multiple decade life spans, consistent water flow, and increased reliability compared with the other renewable energy producers [15]. The drawbacks are the initial cost of construction, the difficulty in locating an acceptable location to build a facility, the effect on local wildlife, the flooding of hundreds of acres of land, and affecting the downstream environment's water quality and quantity [15].

2.2.4. Solar Photovoltaics. The most abundant fuel source in the realm of renewable energy is the sun. Solar panels produce electricity through individual photovoltaic cells connected in series. This form of energy collection is viable in regions of the world where the sun is plentiful, and can be used in isolated regions or on houses to supplement the rising cost of electricity from a power grid. To convert the sun's energy, the cells capture photons to create freed electrons that flow across the cells to produce usable current [16]. The efficiency of the panel is determined by the semiconductor material that the cells are made from as well as the process used to construct the cells. Solar panels come in three types: amorphous, monocrystalline, and polycrystalline [17]. The more efficient the material the panel is constructed from, the greater the cost. To maximize results, there are many features that can be used to control the output of the photovoltaic panels. The power needs determine what components are used to produce the desired voltage and current for the project such as converters, solar trackers, and the size of the panel. Converters transform the variable output from solar panels to constant voltages to maximize the continuous supply of usable power for either present needs or stored for future use. The output power of the panel is affected by many variables that continually changes throughout the day. This produces fluctuations in voltage and current that makes the panel inefficient unless the outputs are constantly

adjusted to maximize the power output. The oscillating conditions are determined by environmental factors, chemical composition of the panel, and the angular position of the sun [16]. Since solar energy is only produced during the day, requiring an energy storage application by either a battery or connecting to the power grid to provide power during the night.

2.3. WEATHER AND SOLAR ENERGY

Many factors contribute to the maximization of the output power of solar panels include cloud cover, temperature, and the angle of the sun. Changing seasons complicate the design of the solar system, since all factors are constantly varying. The light intensity is less in the winter months than in the summer due to the differences in the sun's height at the summer and winter solstice [18]. During the year, the sun moves between its highest apex in the sky at the beginning of the summer and its lowest at the beginning of winter. The angle at which the panels are placed on their mounts determines how much energy is collected and how much is reflected off the surface. Most structures use fixed-angle mounts that are positioned for either a specific season or a midpoint to average the summer and winter outputs. Increasing the number of hours a panel generates at peak efficiency entails the use of a power tracker to follow the sun across the sky. This system tracks the sun and adjusts the angle of the panel to allow the cells to capture more photons than a fixed-position mount. The panel on the power tracker generates more current in the morning and evening hours, increasing the number of hours the panel will gain maximum energy. Temperature variations have a noticeable effect on photovoltaic cells. As the temperature increases, the efficiency of the panel decreases, but, at the same time, temperature coincides with higher levels of illumination [18]. Figure 2.2 shows that increasing temperature decreases the voltage, compared with the output current under the same conditions. Weather determines the amount of light that reaches a panel due to cloud cover. Information on the average number of clear and cloudy days, for a region is incorporated in designing the system parameters such as panel size, converters, and how the panel's energy is stored for different seasonal weather patterns.

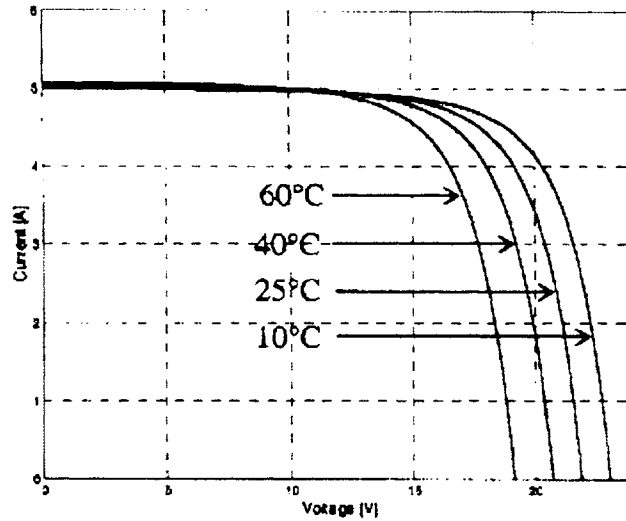

Figure 2.2. Voltage and Temperature Variations of a Photovoltaic Cell [19]

The amount of power generated is proportional to the temperature, as Figure 2.3 demonstrates. The effect of temperature on the photovoltaic cells must be considered when calculating the maximum energy for a specific time of year. The curves in Figure 2.3 represent the point where the maximum power and voltage meet to deliver the highest output to the cell load [17].

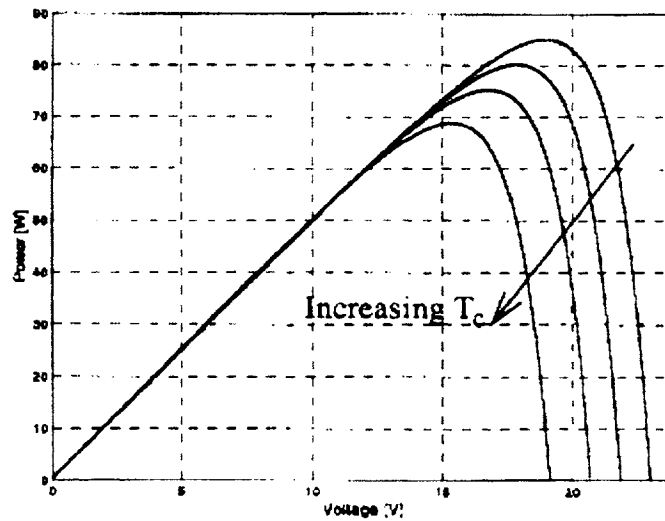

Figure 2.3. Output Power and the Effects of Temperature [19]

How fast the system can recoup the installation cost depends on the yearly intensity of the sunlight. The energy that reaches the ground is called the solar insolation value. The southwest United States will recover the initial cost about two and a half times faster than systems in the Northeast, because the red area, in Figure 2.4, displays a high solar output region and the blue displays weak output locations. The number of sunny days compared with cloudy days determines the color variations, with the sunnier regions being in red [20]. In winter, the farther a location is from the equator the less available energy there is due to shorter days.

Figure 2.4 compiles the average amount of sunlight that reaches the ground every day, and is compared to the number of hours of usable sunlight from two hours after sunrise to an hour and a half before sundown. St. Louis is among the Midwestern cities that receive on average 4,500 watt hours per day. The lower solar insolation values are due to the varying conditions that occur throughout the year and demonstrates the reduced percentage of the sun's rays are reaching the surface due to cloud cover. The percent of the sun's energy that reaches the ground is determined by how many days were clear, partly cloudy, or overcast.

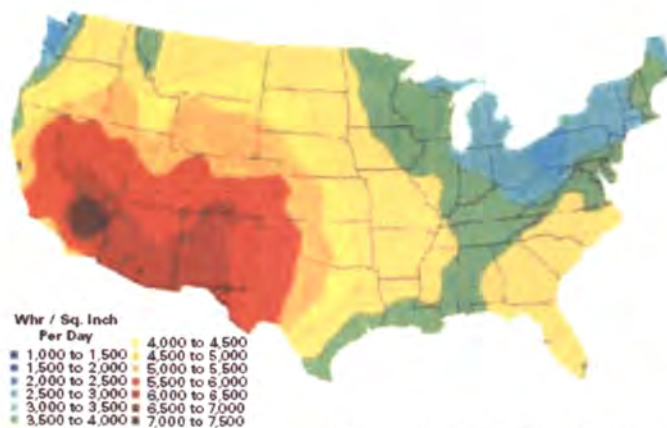

Figure 2.4. Solar Insolation Values for the United States [20]

In St. Louis, the summer months have the longest days and average 10 days of clear skies, while the remaining months average around 8 days of clear skies a month [21]. The winter conditions are cloudy for half the month, decreasing the already-limited

amounts of solar energy available to the panels. Weather conditions affects the design of a solar lighting system, and must be considered when determining what equipment will be needed to provide enough power through spring. A comparison between identical systems in the Southwest and the Northeast, with the same load, demonstrates the differences in design. For both systems to handle the load, the Northeast system may need to be five times the kW size of the one in the Southwest, and that still may not be enough, due to the effects of clouds and wintry precipitation.

Weather plays a crucial role in determining how a system would perform. Wind and wintry precipitation are areas of great concern. The number of available hours of sunlight is limited, and that time is reduced due to the large percentage of snow storms during the winter. Summer storms generate high levels of wind, which increases the danger that light poles will snap. The addition of a solar panel increases the forces on a pole like a sail on a ships mast. To stabilize the pole, control wires are used to increase stability that is diminished with the removal of the power lines. Ice and snow accumulations increase the weight of the panel, increasing the possibility the pole would tilt or snap. Wintry weather in Rolla provided an opportunity to see how ice would affect a panel. Figure 2.5 shows ice on the panel's surface.



Figure 2.5. Panel Covered in Ice at the Start of the Storm

By nightfall, the panel was covered with two inches of snow and ice. The battery containers were covered with over three inches of frozen precipitation and showed no signs of melting in the frigid air. The ability of the sun to remove the ice from the solar panel is dependent on the panels surface temperature and cloud cover; the longer the skies are cloudy the greater the risk of the rack or pole breaking under the added weight. Figure 2.6 shows the panel the day after the snow storm; the ice slid off the panel an hour after the sun had risen. The steepness of the solar panel's angle in combination with the heat generated on the panel's surface melted the ice on the surface of the glass. Figure 2.6 illustrates the ice melted on the panel's surface and then slide off. The ice and snow on the ground took over a week to melt, and the temperatures remained near freezing for the next two weeks.



Figure 2.6. Solar Panel after Ice Melted Off, the Day after the Storm

Figure 2.7 exhibited the thickness of the ice and snow. The solar panel did not collect any energy that day of the storm, but was up and running shortly after sunrise the next day. The support rack showed no signs of damage due to the increased weight.



Figure 2.7. Two-Inch-Thick Ice on the Battery and the Controller Containers

2.4. APPLICATIONS OF SOLAR PHOTOVOLTAICS

Photovoltaic energy comes in three forms: stand-alone, grid-connected, and hybrid system. Stand-alone systems employ a completely independent operation that stores energy in batteries for nighttime usage. The grid-connected form connects directly to the power grid, eliminating the need for batteries. Tying into the grid increases the number of individual users that utilize solar energy on a small scale, and provides the dependability of continuous power no matter the cloud conditions. A hybrid system combines the consistency of the grid with a battery backup, in case grid power is lost.

2.4.1. Grid vs. Off-Grid. Isolated areas and mobile systems are dependent on batteries, whereas places in town have the option of using a power grid, depending on their power consumption and power suppliers. Connecting to a power grid allows the power generated from the panels to be back-fed to the grid when the sun is out, and to run the structure off the line when the sun is down [22]. The cost of purchasing a DC to AC converter with a grid controller, compared to using batteries, varies by the size of the system. Reliance on a grid eliminates the need to replace faulty batteries that plague the long-term operation of stand-alone systems. The drawback to grid connected systems is the number of panels that are needed to provide enough power for the utility company to consider connecting the system to the grid. A grid-connected system must meet the following criteria to function: voltage regulation, frequency regulation, power factor

control, harmonic distortion controls, and quick response time [22]. The amount of power a system generates determines if the energy provided will decrease the amount of the electric bill, or if the excess energy produced would be sold to the power company. During the summer months, high temperatures place increased demand on the power grid due to the large amount of electricity used by air conditioners. Periods of extreme heat are the result of favorable conditions for the sun's energy to reach the Earth's surface. The use of solar panels can supplement the power requirements of the air conditioning system during the period of the day when the temperature reaches its maximum level [22]. Figure 2.8 represents the system required to connect the panel to the power grid.

A DC to DC converter is needed to hold a near constant output voltage. To maximize the output of the panel, a maximum power point tracker (MPPT) controller is used. A MPPT is a boost converter for a single panel or a buck converter when multiple panels are combined in series. The converters produce a near constant voltage value that increases the efficiency of the inverter. The capacitor removes any small variations in the near-constant input voltage to the DC-AC converter. The inverter monitors the power grid to match the standard voltage and frequency. The controller continuously compares the frequency of the grid with the inverter, and adjusts the duty ratio to counter frequency variations.

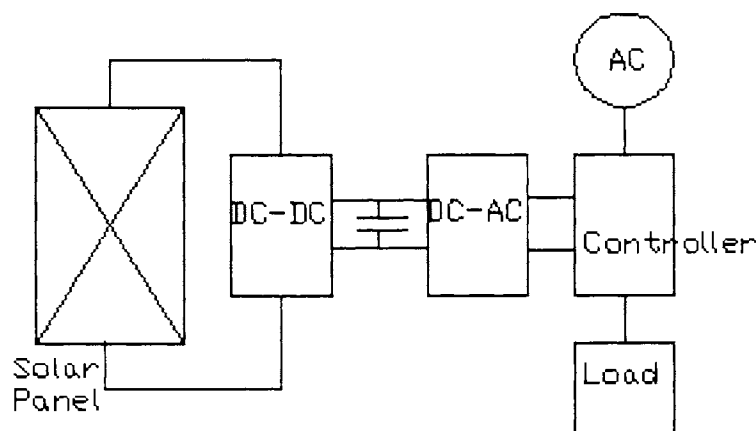

Figure 2.8. Grid Connection Equipment and Layout

2.4.2. Hybrid Systems. A system design that combines the advantages of both a stand-alone setup and a grid-connected setup is deemed a hybrid system. This system relies on the coordination of multiple controllers to continuously monitor the flow of power from the solar panels, and regulate the power to fulfill the needs of the structure, replenish the reserve batteries, and manage the flow of energy to and from the power grid. The basic setup of a hybrid system is shown in Figure 2.9. The equipment consists of the solar panels, a MPPT, a charge controller, batteries, and an inverter [22]. The charge controller monitors the batteries and determines whether or not to charge them. The high-end inverter matches the frequency of the power grid and monitors the grid to detect any loss in power. This system provides an uninterruptible power supply that provides electricity even when the power grid is offline. This system has the highest cost and requires the replacement and maintenance of batteries. The use of this type is limited to industrial applications where backup power may be needed to prevent the stoppage of equipment due to a trip in the power grid.

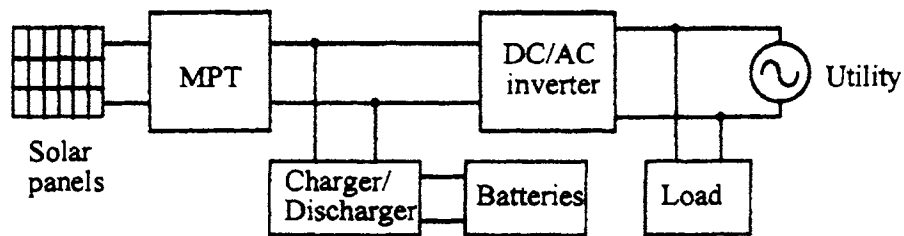

Figure 2.9. Hybrid System Equipment and Layout [22]

2.4.3. Stand-Alone Systems. The earliest application of solar energy was on satellites orbiting the Earth. The first satellites operated for on internal energy sources that lasted for a week to a few months. The first application of a stand-alone system came incorporating solar panels to the satellite to lengthen the operational lifespan to years. The lessons learned from the space program are being incorporated in areas of the world that are secluded from modern civilizations. These locations are removed from conventional power supplies and rely on electricity produced by gasoline generators [9]. The growing expense of fuel has increased the demand from third-world countries

governments to invest in solar energy [9]. In isolated regions that require constant electricity, the primary source of power is solar, with gasoline generators for backup [24]. This stand-alone hybrid provides the reserve power during periods of poor solar insolation, where other designs rely on large battery banks [24]. These hybrid systems are dependent on the cost to transport the fuel and with increasing fuel costs are promoting the conversion to straight solar with the generators as emergency backup.

Stand-alone systems can be built to power small loads, like water pumps and street lights, to the vast loads of a house. The equipment required to build a stand-alone system includes a solar panel, a voltage controller, and batteries. For loads that require AC power, an inverter would be added to the design. To control the output voltage of a panel, an MPPT is employed to increase the efficiency of the power to the batteries and load. The components of each system vary due to the size of the load and the hours of operation during the night. For projects that operate during the day, the battery may only need to last minutes to hours, depending on the load. Systems that have loads that operate at night require determining the number of hours the load operates and from this the panel and batteries are selected. Dependability of the load must be considered to determine the amount of reserve energy the system must have to provide continuous operation. The advantages of a stand-alone system are independent from the power grid, replacement of petroleum-fueled generators, and cost effective compared to running the power lines to remote areas. The disadvantages are the availability of the grid power to most locations, the cost and replacement of equipment, and the loss of power during periods of poor solar insolation.

3. BASICS OF PHOTOVOLTAIC PANELS

3.1. PHYSICAL MAKEUP

3.1.1. Energy Collection. A solar panel is made up of a semiconductor material that converts the light into energy through the use of a silicon composite pn junction. When light hits any material, the energy is reflected, transmitted, or absorbed [17]. The panel absorbs photons from the sunlight that produces excess electrons and holes in the material generating the current through the flow of electrons [17]. For a photon to be absorbed, the energy it provides must exceed the semiconductor bandgap energy [17]. However, the closer the photon's energy is to the bandgap maximizes the cells efficiency and reduces the energy lost to heat [17]. The addition of heat increases the internal resistance of the semiconductor and this increases the amount of energy needed for the electrons to escape the valence bond and thereby decreasing output power.

3.1.2. Internal Characteristics. The flow of electrons is equivalent to the amount of ambient light absorbed by the panel. The flow of electrons to the load stops when the light provided does not generate enough energy to allow the electrons to break free from their bonds. Equation (1) shows the output current of a cell and how it is effected by temperature, T , in Kelvin and the voltage of the cell, V . The component cell current is dependent on the photons, I_{ℓ} and the saturation current of the diode, I_o [17]. The constants are $q = 1.6 \times 10^{-19}$ coul and $k = 1.38 \times 10^{-23}$ j/K. Equation (2) represents the voltage of the cell as a function of the current drawn from the cell, I , and the photocurrent, I_{PH} [25].

$$I = I_{\ell} - I_o * (e^{\frac{qV}{kT}} - 1) \quad (1)$$

$$V = 0.0731 * \ln\left(\frac{I_{PH} - I + 0.0005}{0.0005}\right) - .05 * I \quad (2)$$

Figure 3.1 shows the basic design of a solar panel consisting of the semiconductor material as a fluctuating power source with a resistor that matches the internal resistance of the panel, a diode to direct the current flow, and a resistor for the resistance of the

wires between the cells [18]. The diode prevents a reverse bias current from flowing into the panel from the energy storage devices during the night. The internal resistances of the panel are represented by the shunt, R_{sh} , and the series resistance of the wires, R [19]. The shunt value is very large and the series resistance is very small. These resistance values have little effect on the overall performance of the cells. The controller can be a MPPT or a DC converter, depending on the load. The silicon compound determines what light wavelengths will be absorbed by the panel and at what bandgap energy level [17]. Energy levels below the bandgap pass through the panel as though it were transparent; those levels well above the bandgap are reflected off the surface [17].

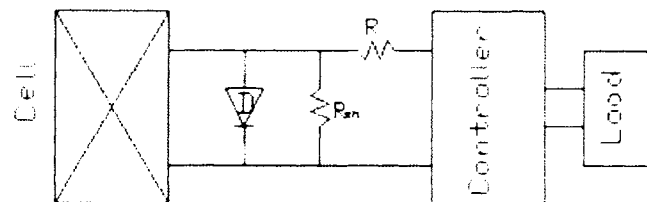

Figure 3.1. Solar Panel Equivalent Circuit

3.1.3. Photovoltaic Material Types. The different elements, primarily silicon make up of the compound determine the efficiency of the panel; the main types are polycrystalline silicon, monocrystalline silicon, and amorphous silicon. Creating a pn junction involves adding an impurity to the silicon wafer to provide holes and excess electrons to determine the size of the bandgap for that compound. Phosphorous and boron are used as impurities in most silicon compounds. The higher the bandgap, the more readily the compound will absorb photons. The efficiency of the panel is determined by how much of the sun's light energy is absorbed by the semiconductor to generate current. The increased efficiency of the panel means more wattage can be produced from the same amount of light [26]. Monocrystalline silicon is grown from a single silicon crystal into large crystalline blocks, which is sliced into a thin wafer that is doped to increase the photon absorption [27]. This compound is expensive, but provides a high efficiency rate of 17%. Polycrystalline silicon is manufactured in the same way as the monocrystalline, but uses multiple crystals to grow the blocks to be cut into wafers

[27]. This process lowers the cost of production, and decreases the efficiency of the cells to 13%. Amorphous silicon is a thin film that is produced in long continuous strips that are many layers thick to maximize output [27]. This is the cheapest and quickest process to produce solar panels, but has the lowest efficiency of all types of silicon compounds: 5% at most. The different chemical composition influences the way electrons flow, how much energy is needed to break the electrons from the valence bonds, and how temperature affects the current.

3.2. HARNESSING THE SUN'S ENERGY

A solar panel is made up of a collection of individual solar cells connected in series or parallel to maximize voltage or current output. The average voltage output for the individual cell is around half a Volt with a current of 400 milliamps. This is dependent on the efficiency of the silicon compound, temperature, and light conditions. A standard 12V panel is laid out with 36 individual cells that are wired into nine cells in series and the four rows in parallel to generate a maximum voltage of 17V to 30V at optimal conditions [28]. The disadvantage of connecting the individual cell stems from varying differences between the cells. Shading and an underperforming cell causes localized power dissipation that is transformed into heat [28]. The output power decrease is a combination of lost energy from the cell and the effects of reverse biasing of the cells that precede the affected one. If a cell completely fails, the row that it is located in will be shorted, considerably reducing the output to the panel. In Figure 3.2, the individual cells are shown in series with forward-biasing diodes to prevent current flow from an outside power source during the night. The more cells connected in series, the higher the voltage. To maximize the current, the cells will be connected in parallel.

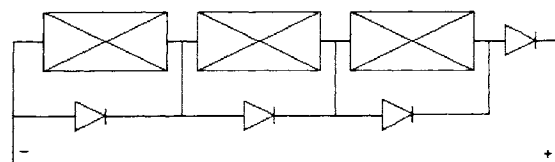

Figure 3.2. Photovoltaic Cells Connected in Series

4. PROJECT DESCRIPTION

4.1. DESIGN CONSIDERATIONS

This project required examining the concepts of how a stand-alone system worked and how to connect the panel, the batteries, and the load together. Investigating commercially-available systems assisted in determining what equipment is required to build a complete stand-alone structure. The next stage was to establish the equipment necessary to operating the system so it would be durable and cost effective. The design of the system began with the amount of lumens needed to illuminate a predetermined area. This information established the wattage and the types of lamp that fit the criteria. The most common types of lamps currently used for outside lighting are the high pressure sodium and the low pressure sodium lamps.

4.2. PROTOTYPE DESIGN

The determination of the lamp dictated the wattage of the solar panel and the batteries. The panel rating established the number of batteries and the type of controller that was necessary to handle the voltage and current outputs. The 100-watt high pressure sodium bulb was selected for this study because it provided the necessary 9,500 lumens to fill the needs of the project, matched the lamps used on city streets, and had a fast start-up time. The energy usage of the lamp determined the number of amp hours the battery would have to provide without recharging for four days. Deep-cycle batteries using lead acid gel are designed to handle the strain of recharging, and have longer life spans ranging from four to seven years, compared with the standard lead acid type with an average lifespan of less than three years. For a panel of more than 150W, the output voltage was 26V, dictating that the system needed two batteries connected in series to limit the current draw on the cells. To control the charging of the batteries, a maximum power point tracker (MPPT) was incorporated to deliver the optimal voltage to increase the efficiency of recharging.

4.3. PROJECT EQUIPMENT

The prototype system, a combination of many forms of equipment that is necessary for the operation of a stand-alone system was built to test the practicality of using solar energy. If the lamp made it through 90% of the nighttime hours, the system provided ample power to build the reserves, and if the fully charged batteries had a reserve capacity of three days, the system was considered successful. The system prototype was comprised of a commercially-available solar panel, a pair of batteries with a life expectancy over five years, an MPPT that could handle the input and output currents, a 100W high pressure sodium lamp assembly, and an inverter that could handle the load. The system was powered by a GE® 165 Watt solar panel that was made of monocrystalline silicon. The batteries were Rolls Surette® HT-8D, and had a 20 amp hour rating of 221 amp hours. To decrease the amount of current needed by the project, the batteries were connected in series to boost the voltage to 24V and to match the voltage output of the panel. Figure 4.1 shows the nerve center of the project is the MPPT shown as the system controller.

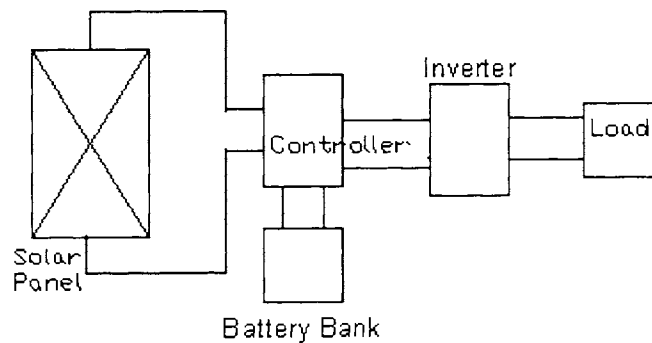

Figure 4.1. The Prototype System Layout

4.3.1. The Photovoltaic Panel. The prototype system was powered by a GE 165W photovoltaic panel. This panel was selected due to its composition and cost. The panel had 54 photovoltaic cells and was the monocrystalline type. To determine the wattage of the panel, a 55W low pressure sodium (LPS) lamp was selected as the load. A

panel with a 200W output was determined to have the best outcome and would provide the necessary energy to build the reserve energy during the winter months. The LPS lamp was the standard for the solar lighting systems sold in the market and was replaced with a 100W high pressure sodium (HPS) lamp during the construction phase. The total cost of the system was also a consideration of the project. Due to the high cost of solar panels, the minimum-sized panel was selected to aid in keeping the cost down. As Shown in Table 4.1, the voltage and current characteristics of the panel can be used to determine whether the panel was receiving power or was being shorted when the batteries were fully recharged. The voltage varied throughout the day, from 24.5V at dawn and sunrise to 28V at the solar noon. The current fluctuated in the range of a few hundred milliamps to a maximum of 6.6A. The panel was mounted on a Unirac® (Albuquerque, New Mexico) frame that held the panel at a constant angle of 38 degrees. The angle was selected to increase the power collected during the winter months with limited power loss in the summer.

Table 4.1. GE 165W Solar Panel Values

Maximum Wattage	165W
Short Circuit Current	7.4A
Maximum Power Point Current	6.6A
Open Circuit Voltage	32V
Maximum Power Point Voltage	25V
Length x Height x Width Inch	58.1x38.4x1.4

4.3.2. The Maximum Power Point Tracker. The MPPT was the focal point of the system; connecting the panel, battery bank, and the load, shown as the controller in Figure 4.1. To prevent overcharging, an MPPT maximized the amount of energy that reached the batteries. When the battery voltage fell below 23.2V, the MPPT disconnected the load. The power to the load was reconnected when the voltage level rose above 25.2V. A 24V Morningstar® (Washington Crossing, Pennsylvania) SunSaver 20 was used in the prototype to control energy flow in the system and to protect against a current draw over 20A. The MPPT was stored in the control's box with the inverter as shown in Figure 4.2. The SunSaver accomplished the necessary task of preventing the

batteries from being overcharged when the LED lamp was connected, and prevented the batteries from being completely drained by the HPS lamp. The cost and size made this piece of equipment worth the expenditure, and provided the platform to wire all the components together in a way that maximized the energy stored and used during the test.

The MPPT used a pulse width modulation to deliver a constant charging voltage to the batteries, and thus produced a stable charge current. Additionally, the controller monitored temperature and made adjustments to handle the electrochemical properties of the battery to limit the amount of heat gained during charging. Maintaining a constant power output requires a power converter to control the voltage and current to match a specified range that maximizes output efficiency and prevents overcharging the capacitor [29]. The use of a MPPT increases efficiency and lowers the cost and amount of equipment needed for the system. Compared with a much higher wattage panel that produces the same amount of energy, a smaller panel with an MPPT will equal the average power produced. Figure 4.2 shows the MPPT installed in the control container.



Figure 4.2. The SunSaver 20 Maximum Power Point Tracker

The benefits of the MPPT are in the savings realized by using the smaller panel and the increased efficiency of all systems connected to it. The output voltage was held constant, while the output current was dependent on the light intensity and temperature of the panel [30]. The use of microprocessors to calculate the changing variables with the

system designed algorithms that control the duty ratio of the circuitry increases the dependability of the power [31]. Constantly monitoring the load allows for adjustments to be continuously made by moving the operating points up or down to hold the current and voltage at the maximum power point. The control flexibility and constant monitoring provide increased systems production and monitors the condition of the battery to prevent damage due to over-charging and over-discharging. The MPPT optimizes the voltage to provide the most favorable recharging conditions, at 13.5V, to properly charge the cells. With less than desirable voltage, the battery will not properly recharge; with excessive voltage the battery will overheat, causing terminal damage to the battery cells. To prevent over-charging when the battery is fully charged, the MPPT will switch from normal charging currents to a value that holds the cells at their peak level. This trickle charge can cause damage to the battery if the cells have been at maximum capacity for many days, thus decreasing the lifespan. There is a limit to the level of the output voltage the MPPT will provide. In combination with a power converter, the voltage output will match the input characteristics of the load or capacitor [23]. The same system of power converters can be used to transform energy from batteries into the power grid, as either a backup system or to release stored energy during peak hours of usage [32].

4.3.3 The Inverter. The basic design of an inverter is to convert DC power to AC and to monitor the load current to guard against power surges. The prototype system was designed to handle the output voltage of 24V generated by the panel. The power of the load was the second factor that went into determining the type of inverter. A 24V Power Bright® (Quebec, Canada) inverter matched all criteria for the project and was capable of supporting 900W of output. The output voltage was 120V AC, with a maximum current output of 7.5A. The inverter input voltage operated between 22V and 30V DC, and automatically shut off when the input current exceeded 15A. This inverter was selected for this project due to the size of the load and the output voltage of the panel.

The standard operating voltage of most inverters is 12V. The options for the project were to purchase an inverter that could handle a load of 500W and could run off 24V, or use a 12V inverter with a DC-DC converter to reduce the voltage. The second option added more to the cost of the system and decreased the amount of energy that

reached the load. The final selection came down to availability of 24V inverters. The wattage requirements eliminated all but the 900W inverter. This inverter was designed for military applications, and could handle any conditions the system would face during the winter months. Figure 4.3 shows the inverter in the control container.



Figure 4.3. The Power Bright 900W Inverter

4.3.4. The Batteries. Batteries are used on most individual systems, such as solar homes and mobile applications. There are many types of batteries that can be used to supply the power including lead-acid, nickel cadmium, and nickel zinc. The lead acid battery was the most commonly used of the group, due to its low cost, and the efficiency of charging and discharging is 90% [17]. Temperature affects the performance of the battery by changing the internal resistance of the cells. A temperature around freezing lowers the discharge rate, but increases the time the battery can hold a charge. Higher temperatures above 105°F have an opposite reaction compared to colder temperatures, with higher discharge rates [17]. This energy loss is due to the internal resistance of the battery and heat generated during recharging. There are two types of lead acid batteries, standard and gel filled. The standard batteries have a limited range in the amount that can be discharged; the higher the daily discharge, the lower the number of recharging cycles the battery will have in its lifetime. Lead acid gel batteries are designed to handle

discharges down to 20% before serious damage occurs, and are able to handle the daily long-term needs. Nickel Cadmium batteries have a lower efficiency of 85%, and are more expensive than lead acid types, but have a wider temperature range and are less susceptible to over-charging [17]. The military, large industrial plants and the space program use nickel cadmium, due to its high durability and higher economic rate of return on large projects. Nickel zinc is a newer form of battery that is being developed to have a higher energy density and longer life span than those used today on solar projects [17]. This is a future contender to the lead acid gel, but the next generation must increase the dependability and lower the cost to replace the gels.

The main drawback to using a stand-alone solar-powered system is the lack of sunlight at night. To operate equipment 24 hours a day requires an energy source that comes in the form of a battery, fuel cell, or connection to a power grid. To supplement for this weakness, energy collected in the daylight hours must be transformed from flowing electrons into a chemical compound that retains the energy. The standard solar-powered system uses batteries with voltages of 4V, 6V, or 8V. All batteries had to be a heavy-duty deep-cycle battery with the longest warranty. The standard batteries were rated for up to five years. Figure 4.4 shows one of the batteries used in this project.



Figure 4.4. The Rolls Surrette HT-8D Battery

The battery selected for this project is not meant for use on a solar project, but is a deep-cycle lead acid gel, and has a warranty of seven years. The Roll Surrette® (Salem, Massachusetts) HT-8D, seen in Figure 4.4, is a marine battery that is cost effective and capable of handling the varying weather conditions. In the prototype system, two HT-8D batteries were connected in series, producing a 24V battery bank. Table 4.2 demonstrates how the amount of current used by the load effects longevity of the individual battery. Loads that require less current have a higher capacity-to-amp-hour ratio.

Table 4.2. Level of Discharge and Battery Longevity of Rolls Surrette HT-8D [33]

Capacity	CAP/AH	Amps
20 HOUR RATE	221	11.1
15 HOUR RATE	208	13.8
12 HOUR RATE	197	16.4
10 HOUR RATE	188	18.8
8 HOUR RATE	177	22.1
6 HOUR RATE	164	27.3
5 HOUR RATE	155	31
4 HOUR RATE	144	36
3 HOUR RATE	130	43
2 HOUR RATE	113	56
1 HOUR RATE	80	80

4.4. TYPES OF LIGHTING

The purpose of street lighting is to improve safety and provide security. The energy requirement to power most large city streets is in the billions of watt hours a year [34]. The large amounts of energy required to operate the lights make using a solar powered lighting system a topic to study. The key component for a solar-powered street light is the power needs of the load and the lumens output by the lamp. The different lamps considered for this project were the HPS, LPS, fluorescent, and LED lamps [35]. The most common type is the HPS that is used in most communities across the United States. The other notable types, used in commercially available stand-alone systems are the fluorescent, LPS, and LED. These lamps come in many wattage levels and different foot-candle ratings that fulfill the needs of a specific region or application. The basic

design of most commercially available stand-alone street lighting systems incorporates lighting loads that work best in areas with high solar insolation conditions and moderate weather conditions. This section covers each type of lamps and how they can be incorporated into a stand-alone system. Analysis gained from the study of stand-alone systems benefits the utility company by researching ways to improve efficiency, decrease light pollution, and provide a safer environment for drivers [34].

4.4.1. High Pressure Sodium Lamp. The most common type lamp employed for street lighting is the HPS lamp. This lamp reigns as the top selection due to the good color rendering, long lifespan, and have the ability to be used on high traffic streets. Its main advantage over the other lamp types is the ability to handle variations in temperature, color range and uniformity rating [35]. The lamp runs off AC power, and consists of sodium under high pressure, that expands the range of wavelength produced in the light; the prevalent wavelength produces an orange glow [35]. This lamp was selected for the project due to the fact that it was the most widely-used lamp in the country. The prototype lamp was 100W high pressure sodium light made by Cooper® (Peachtree City, Georgia) Lighting. The lamp used for the HPS tests shown in Figure 4.5.



Figure 4.5. The 100W High Pressure Sodium Lamp

The drawback to using the HPS lamp is that it requires an inverter to operate. The 100W bulb matched what is used on most city streets, and corresponded to the 9,500 lumens required to meet government ratings. The lamp consumed 3.1A during startup, and ran at a constant 2.2A when the system was running normally. It consumed 230W to operate, and was not as efficient as the lamps used on highways. The larger power requirements of this lamp prevented the prototype from reaching the designed criteria. The efficiency of HPS light system was dependent on the efficiency of the ballast and the transformer; the better the internal equipment, the less power was required.

4.4.2. Low Pressure Sodium Lamp. The primary lamp suggested for the majority of commercially-available street lighting systems, is the LPS lamp. The designs on the market focus on regions in the southwestern United States and in remote locations around the world that have tropical climates. The lamp consists mainly of sodium gas that becomes excited when a DC current passes through the lamp. The lamp ranges between 18W and 180W, with ratings of 1,800 and 33,000 lumens [35]. The main advantages of the LPS system are that the lamp runs off DC power, and it does not require an inverter like the HPS system. The focus of this project was to select a lamp that would match the preset of 9,500 lumens, which falls between the 55W and 90W ratings with 8,000 and 13,500 lumens [35]. The best option for the project was the 55W bulb, due to the lower power demand; this load would have lasted around 3.5 days in winter under overcast conditions. For this project, the LPS lamp was deemed unsatisfactory due to the fact that the lamp produced a yellowish glow that reduces the color-rendering ability of the driver and communities prefer to utilize the HPS lamp.

4.4.3. Fluorescent Lamps. The fluorescent lamp works on the principle of passing DC current through the low pressure atmosphere filled with argon gas and vaporized mercury to produce light in the ultraviolet spectrum [35]. To convert to visible light, the glass is coated with a phosphorous coating. The typical power ranges are the 40W and 72W lamps that output 2,900 to 5,800 lumens for street lighting systems that are on the market [36]. Fluorescent lamps output a white light that improves the quality of the environment they illuminate. The LPS lamp provides more light per watt, but at the cost of color rendering. Fluorescent lighting has one major downside, the output lumens drop when the air temperature falls below 80°F [35]. If the ambient temperature

drops below 40°F, the lamp yields half its lumens [35]. This alone relinquishes this lighting source to tropical climates, where nighttime temperatures rarely fall below the 50s. Fluorescent lighting applications work best for interior lighting, and should not be considered for a project in the area of this study.

4.4.4. Light Emitting Diode. LED lights are the newest form of lighting to come to the commercial street lighting market. In the last decade, the use of LEDs has grown from indication lights on electronics to widespread acceptance for traffic signals. The next step will be the development of current LED street lights to match the requirements for highway use and replace the HPS lamps. Current models have an output of 1,200 lumens and operate off of only 20W [37]. To generate the most concentrated light, the individual LED bulbs are angled to focus the light onto a small area. This reduces the radius covered by the light to a specific area. Figure 4.6 illustrates the LED lamp in operation, with 400 individual LED bulbs producing an aesthetically pleasing bright white light.



Figure 4.6. Light Emitting Diode Street Lamp in Operation, February 2007

The small focus area of the LED light and the reduced cost makes this a useful lamp for stand-alone systems due to the small load requirements [38]. The advantages of

LED lighting are the elimination of glare, reduced light trespass, and reduces light pollution [37]. Light pollution occurs due to poor design of street lights that do not channel the light towards the ground, and a portion is wasted skyward. Figure 4.6 demonstrates the abilities of the M400 Cobrahead street light. The lamp operates 400 Warm White LED bulbs to produce a clear light that generates little glare [37].

Illuminating large areas of major highways requires bright HPS lights that can affect a driver's night vision and produce glare off the surface of the moving vehicles. The small load requirements of the lamp work well with batteries, due to the low current draw [39]. The drawbacks of current LED lamps is that the lumens produced do not meet the requirements set by the highway department, and are up to five times more expensive than conventional HPS lamps. Current applications that work well with LED lights are walkways, parking lots, and ornamental lighting [38].

5. PROTOTYPE PHOTOVOLTAIC STAND-ALONE SYSTEM RESULTS

5.1. PARAMETERS OF THE SYSTEM TEST

The criterion that the prototype system was designed to meet the capacity to operate for four days under continuous overcast skies in the winter months. The design of this prototype was to operate with a 100W HPS lamp in the region around St. Louis, Missouri. The construction of the prototype system had to fulfill the needs of the load, be cost-effective, and have a straightforward and reproducible design. Observations were done on how the prototype system fared with the HPS lamp under the weather conditions of the Midwest. The next phase focused on determining the feasibility of using an LED street lamp as a more efficient replacement for the HPS. The last test examined the affects a constant load had on the operation of the project. From the combined data, a final evaluation of the prototype system would assess the likelihood that the project would be used on city streets or to determine other applications of lower importance to test new design changes. Secondary applications provide an avenue for further study that uses new technological advancements to improve the design of the stand-alone system.

5.2. RECORDING EQUIPMENT

To gather data without constant measurement required a data recorder to continuously collect real-time data to monitor the changing values that occur as the sun crosses the sky. To verify that the data recorder's values were accurate, a handheld current and voltage recorder was also used. The need to document nighttime readings required recording the batteries' voltages and capturing the waveforms from the test. The graphs were compared with the data recorder data to ensure that the data matched. The data recorder was purchased from National Instruments® (Austin, Texas), and used the program LabView 8.0 to monitor the voltage and currents generated by the test system. The handheld device used to corroborate the results of the data recorder was the Fluke® 43 Voltage and Current Probe.

5.2.1. Handheld Recorder. The current and voltage were measured with a handheld recorder to provide a more constant approach to monitoring the power flow. The Fluke Probe is a multimeter that allows the waveform to be captured for later study. Figure 5.1 shows the current measurement made on the AC side of the inverter with a voltage of 120V. The prototype lamp ran at a constant current of 1.89A rms during the night, with an inrush current of 3.4A rms. The combined current loss of the inverter and MPPT was 0.3A.

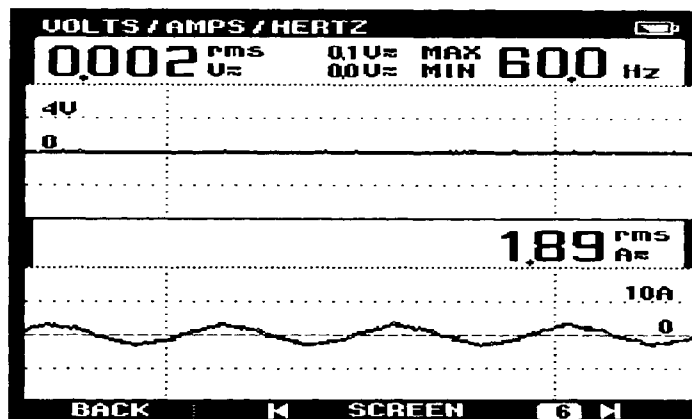

Figure 5.1. Fluke Probe Current Measurement Hours after HPS Startup

The values recorded by the data recorder on the DC side of the system show the current at about half the size of what the value was calculated to be. The Fluke meter was not designed to measure DC current, but the output current was calculated by dividing the output power by the recorded voltage. The fluctuations in Figures 5.2 and 5.3 were caused by the inverter. For this test, the MPPT was disconnected from the load and the inverter connected directly to the batteries to demonstrate the effects of the inverter. The first reading was taken when the lamp current stabilized after startup. The tight quarters of the container prevented the measuring of both voltage and current on the same graph. The corresponding voltage was measured at 26.0V. Figure 5.3 shows current measurement just before sunrise to record the current change with a voltage of 24.8V. The current drawn at sunrise was 0.5A higher after 14 hours of use. As the voltage fell, the current output steadily increased.

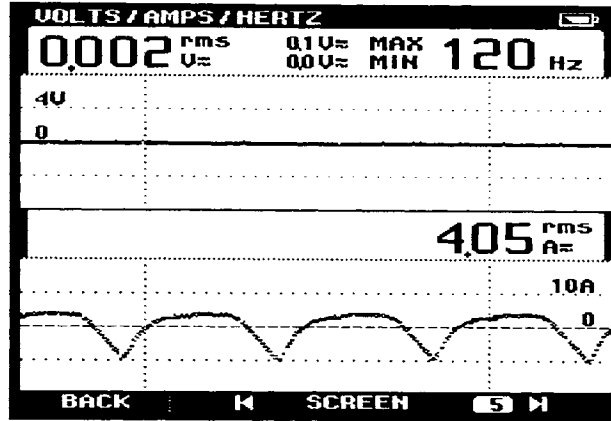

Figure 5.2. Fluke Probe Current Measurement at Sundown on Nov. 17, 2006

It was observed that the lower the starting voltage was, the faster the load drained the batteries. The boost of the internal resistance of the batteries accounted for the additional energy losses. The current value changed when the load and batteries were run through the MPPT. The power requirements of the load did not change, so the variations are attributed to the MPPT guarding against an overcurrent.

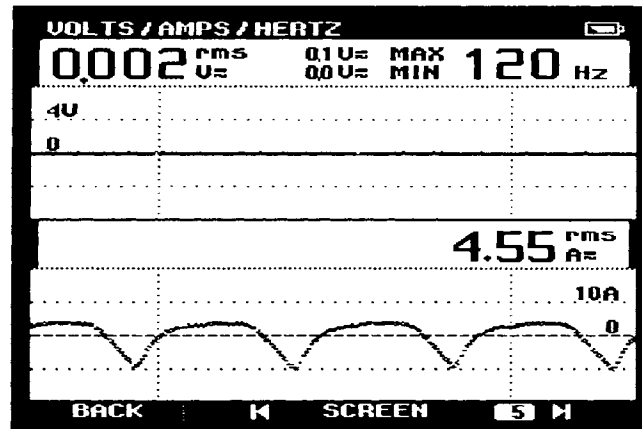

Figure 5.3. Fluke Probe Current Measurement before Sunrise on Nov. 18, 2006

The LED lamp had a load less than one amp when the first measurements were made. The Probe had difficulty recording a current measurement on the DC side of the system. The results of the recording on the AC side matched the manufacturer's data

sheets and the data recorder. Figure 5.4 shows the values collected from the LED lamp, which match the manufacturer's data sheets.

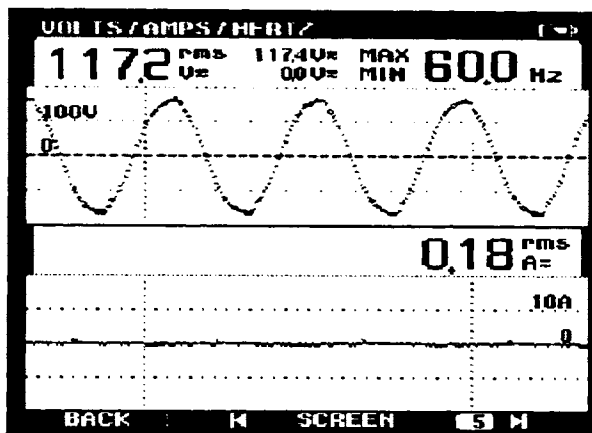

Figure 5.4. Fluke Probe Measurement on the AC Side of the LED Lamp

5.2.2. Data Recorder. The National Instruments PCI-6221 data recording card was selected to collect voltage and current readings of the system. These data were broken into three areas of study: the panel, batteries, and load. The prototype system was constantly monitored by DC voltage and current sensors approved by National Instruments to work with the hardware. The program, LabView 8.0, sampled the voltages and currents of the load, batteries, and panel every 2.5 to 3 minutes providing 20 to 24 data points an hour. The data were exported to a notepad file, and each file was saved every 24 hours beginning at 8 a.m. The data were imported into Excel to produce a detailed spreadsheet that was compiled into graphs to simplify the analysis. The values in Table 5.1 were recorded on November 20, 2006—a mostly clear, sunny day in which a constant current was provided to the batteries. During the majority of the month, the data collection occurred on mostly cloudy or partly cloudy days. December 2, 2006 had clear skies and represented the best results that would be produced for this study.

The values recorded on the night of November 19, 2006 illustrate the varying current values as shown in Table 5.2. The output current was known to be constant, but the current waveforms on the DC side fluctuated due to the constant switching of the

inverter. The switching generates sine wave into the batteries and prevents the sensors from providing the consistent current value.

Table 5.1. Daytime Measurements of the 165W Solar Panel on November 20, 2006

20-Nov-06	Voltage (V)			Current (A)		
Time	Panel	Battery	Load	Panel	Battery	Load
12 p.m.	26.728	26.626	26.665	6.125	-5.568	0.272
	26.721	26.636	26.650	5.959	-5.417	0.403
	26.786	26.646	26.653	6.230	-5.664	0.210
	26.772	26.632	26.640	6.309	-5.736	0.152
	26.701	26.609	26.681	6.293	-5.721	0.142
12:15	26.772	26.653	26.663	6.338	-5.762	0.152
	26.740	26.665	26.669	6.110	-5.555	0.133
	26.776	26.661	26.683	6.207	-5.643	0.136
	26.754	26.649	26.685	6.110	-5.555	0.133
	26.795	26.663	26.661	6.187	-5.624	0.146
12:30	26.813	26.690	26.683	6.195	-5.632	0.143
	26.834	26.663	26.661	6.202	-5.638	0.144
	26.790	26.663	26.673	6.145	-5.587	0.145
	26.756	26.642	26.677	6.061	-5.510	0.146
	26.813	26.646	26.638	6.013	-5.466	0.160
12:45	26.754	26.640	26.692	6.083	-5.530	0.143
	26.772	26.682	26.714	6.100	-5.545	0.146
	26.797	26.678	26.704	5.985	-5.441	0.146
	26.779	26.651	26.671	5.951	-5.410	0.148
	26.708	26.619	26.653	3.894	-3.540	1.993
1 p.m.	26.795	26.709	26.731	6.027	-5.479	0.130
	26.806	26.690	26.708	5.993	-5.448	0.144
	26.799	26.692	26.712	5.958	-5.416	0.141
	26.793	26.663	26.657	6.145	-5.587	0.145
	26.820	26.690	26.700	5.803	-5.275	0.136

The current values were determined the same way as the Fluke® (Everett, Washington) Probe current by dividing the output power by the input voltage. Another problem that arose with the data recorder was that when the outside temperature was below 50°F, the ability of the program to collect usable data was compromised. The data provided had values that were outside the range of the panel and the batteries. The end result was the loss of usable data, and the data required continuous monitoring to prevent LabView from recording false values. The only solution that worked was that when

invalid data was output, the computer was restarted, and for half-hour periods of time the data was verified and found to be correct. When the program was not monitored, the results were full of errors. To build the graphs in Excel, the invalid data was replaced with values from days when the system was operating correctly. To improve the results, the weather of each day was recorded to use for comparison with later days that required repair. Overall, the daytime values had less damage due to the higher temperatures, and the time period when the containers were covered in ice had lower amounts of poor data.

Table 5.2. Nighttime Measurements of the HPS on November 19, 2006

19-Nov-06	Voltage (V)			Current (A)		
Time	Panel	Battery	Load	Panel	Battery	Load
9 p.m.	0.1245	24.3024	24.2754	-0.0046	5.2539	5.1738
	0.1543	24.3902	24.3638	0.0043	3.4424	3.3643
	0.1657	24.4048	24.3823	0.0023	2.6909	2.6059
	0.1245	24.3630	24.3761	0.0043	1.7832	1.7060
	0.1749	24.4111	24.4049	0.0013	1.5280	1.4559
	0.1153	24.3526	24.3679	0.0033	1.7476	1.7100
9:15	0.1589	24.3609	24.3474	0.0082	2.4437	2.4061
	0.1245	24.2522	24.2528	0.0260	5.8927	5.8749
	0.1474	24.2020	24.1664	-0.0056	8.2847	8.3342
	0.1566	24.1497	24.0841	0.0052	12.5209	12.5723
	0.1428	24.1602	24.0965	-0.0027	11.3501	11.2483
	0.1818	24.2104	24.1541	-0.0135	8.1374	8.0652
9:30	0.1084	24.2041	24.2322	0.0201	5.4903	5.3904
	0.1543	24.2480	24.2158	-0.0116	4.2681	4.1989
	0.1245	24.2543	24.2466	0.0003	3.1329	3.0479
	0.1795	24.3066	24.2857	0.0013	2.5881	2.5139
	0.1589	24.3045	24.3042	0.0072	1.7861	1.7060
	0.1382	24.3024	24.3124	0.0092	1.5340	1.4865
9:45	0.2368	24.3735	24.3268	-0.0116	1.5884	1.5083
	0.1061	24.2543	24.2692	0.0191	1.8000	1.7327
	0.1153	24.2062	24.2178	0.0062	3.7489	3.7331
	0.1543	24.1623	24.1129	-0.0155	5.6742	5.6989
	0.1657	24.1079	24.0512	-0.0046	9.4061	9.4624
	0.0993	23.9950	23.9710	0.0141	11.8267	11.8722
10 p.m.	0.1268	24.0410	23.9978	0.0072	12.0186	11.8940

The extreme cold spell had a dreadful effect on the results, and every night was monitored to increase the accuracy of the test. However, the program could not be

monitored continuously throughout the night. Repairs to the HPS test data were less demanding than for the LED test, because the light would go off before 1:00 a.m.

5.3. LIGHTING LOADS

To test the effectiveness of the prototype system, four tests were observed using the HPS, LED, and fluorescent tube lights. The results were monitored by the data recorder, and the data were correlated with values collected with the Fluke Probe to increase the accuracy of the test. The primary test centered on the HPS lamp during the winter months to determine the feasibility of the system to handle the low solar insolation values and the energy consumption of the lamp. The fluorescent light test established whether the system could handle a constant load during the day and night. The data gathered during the daylight hours made up the key component extrapolated from the data. The final test looked at the practicability of using an LED street lamp and determining what applications the lamp could work with the prototype system in real-world locations.

5.3.1. High Pressure Sodium Lamp. This lamp was the primary test subject for the prototype system. To gather as much information about the performance of the system, two tests were performed: one covered late November to mid-December 2006, the second covered most of January 2007. The weather conditions during this time provided a glimpse on how ice and snow can affect the operation of the panel and how long the frozen precipitation stays on the surface. The short days and long nights put the system in the worst case situation and showed how the temperature affected the panel. The angle of the sun was observed during both tests and the voltage on the panel increased as the winter solstice drew near.

5.3.1.1. Test one. During the latter parts of November, the project was set to run consecutively for a month to gather data that would be used to the systems' capabilities and limitations. Figure 5.5 shows the current and voltage that were recorded on December 2, 2006. This shows how the voltage increased throughout the day and the effect that clouds had on the system, causing the drop in voltage between the sixth and seventh hour. For individual days the time is set in military time.

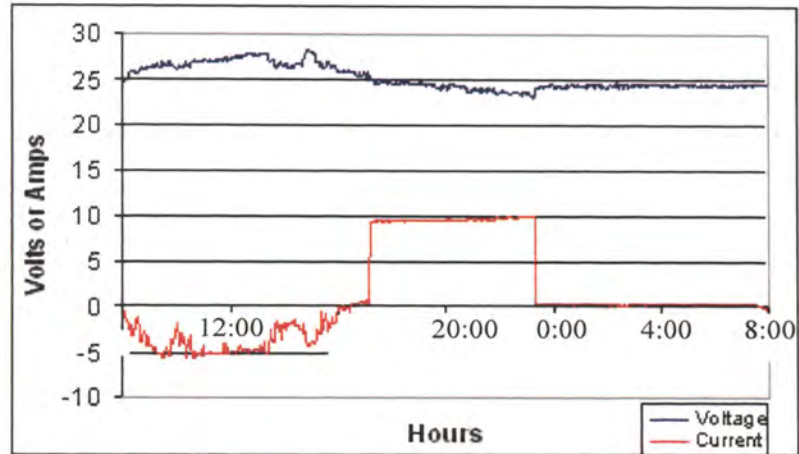

Figure 5.5. HPS Test One, Battery Values on December 2, 2006

The current was negative when the batteries were charging and positive when they were discharging. The current fluctuations recorded by the program prevented accurate monitoring, but the data showed the time when the light shut off. When the current was zero, the voltage level reached 23.2V and the MPPT disengaged the load at 11:15 p.m. For a better perspective, the recorded voltage is shown in Figure 5.6. The batteries voltage reached a maximum of 28.1V and a minimum of 23V.

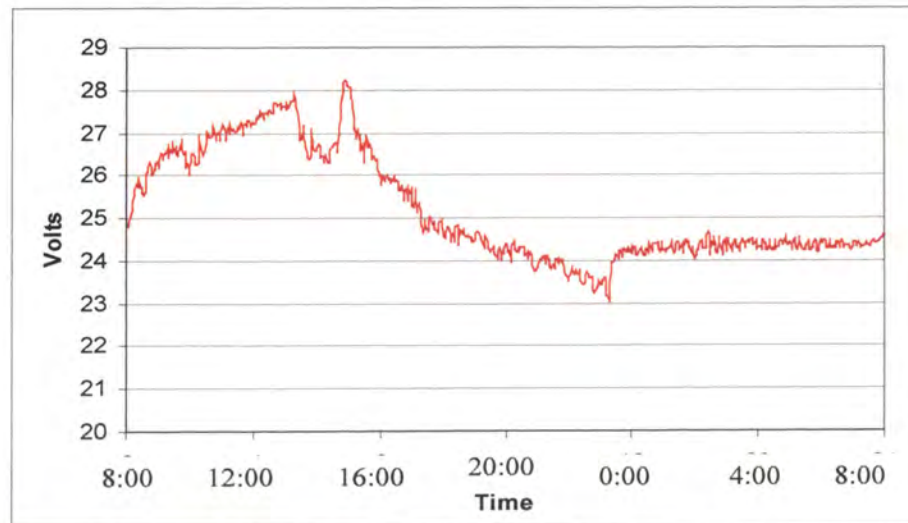

Figure 5.6. Battery Voltage on December 2, 2006

Figure 5.7 shows a better perspective of the input power versus the output power. The amount of power collected from the panel throughout the day ranks between 0 and 155W. The effect of thick clouds reduced the available sunlight at the 4-hour mark the sun was at its peak, but thin layers of clouds prevented the panel from peaking at its maximum of 165W. The loss of solar noon reduced the effectiveness of a solar panel and reduces the time the lamp was on. In 8 hours the panel collected enough power to run the lamp for 6 hours. The output wattage was calculated due to the oscillations of the data collected due to the inverter switching. Figure 5.7 starts at 8 a.m. with the sun down at 5:15 p.m.

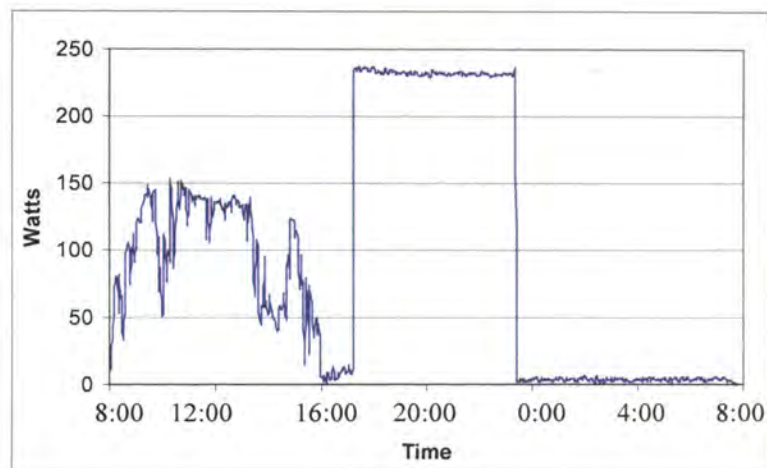

Figure 5.7. Battery Wattage with Calculated Nighttime Values on December 2, 2006

The clouds cost an hour of run time from the test. Figure 5.8 displays the power that reached the batteries on a mostly clear day in December 2006. The clouds were mostly high in the upper levels of the atmosphere, but they reflected enough sunlight at solar noon to prevent the panel from reaching its maximum potential. The battery current collected by the sensors and the Fluke Probe was collected for later analysis. The oscillating waveform prevented the recording of a DC current. Table 5.3 shows the current that was calculated using the known output voltage and current of the inverter and the recorded voltage from the sensors.

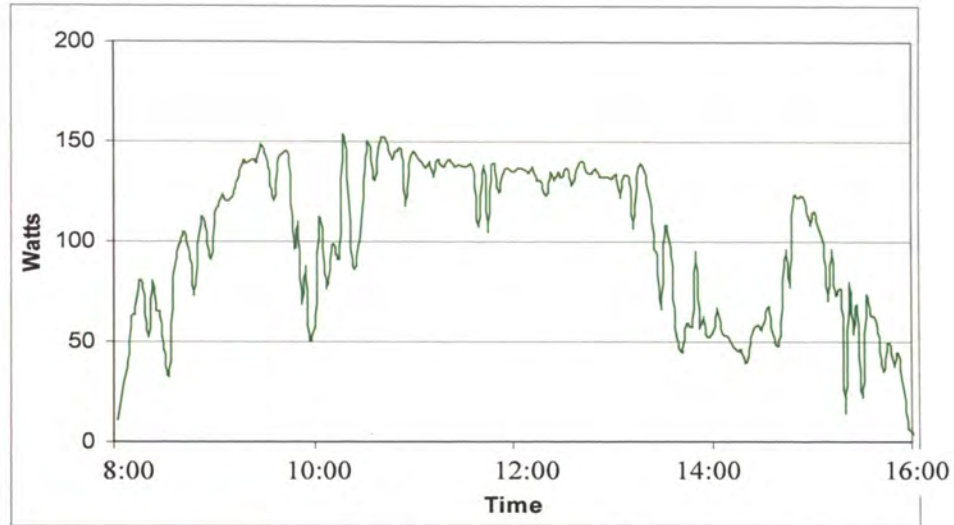

Figure 5.8. Input Power to the Batteries on December 2, 2006

Table 5.3. Calculated Battery Currents on December 2, 2006

Time	Load V	Current
6:15 p.m.	24.783	9.280
	24.769	9.286
	24.539	9.373
	24.449	9.407
	24.650	9.331
6:30	24.442	9.410
	24.750	9.293
	24.804	9.273
	24.861	9.252
	24.376	9.436
6:45	24.721	9.304
	24.629	9.339
	24.775	9.284
	24.622	9.341
	24.551	9.368
7:00	24.616	9.343
	24.568	9.362
	24.551	9.368
	24.453	9.406
	24.551	9.368
7:15 p.m.	24.419	9.419
	24.562	9.364
	24.543	9.371
	24.675	9.321
	24.675	9.321

The power output is constant and the slopes of both lines are equal to the 230W output. The initial values of the graph are 9.1A at 25.2V, and the load drains the batteries over the time period thus reducing the voltage and increasingly draining the current. The MPPT shuts the lamp off at 11:15 P.M., 6.5 hours short of sunrise. The best result from a clear day puts the shutoff time within half an hour after midnight. The calculated DC currents are shown in Figure 5.9.

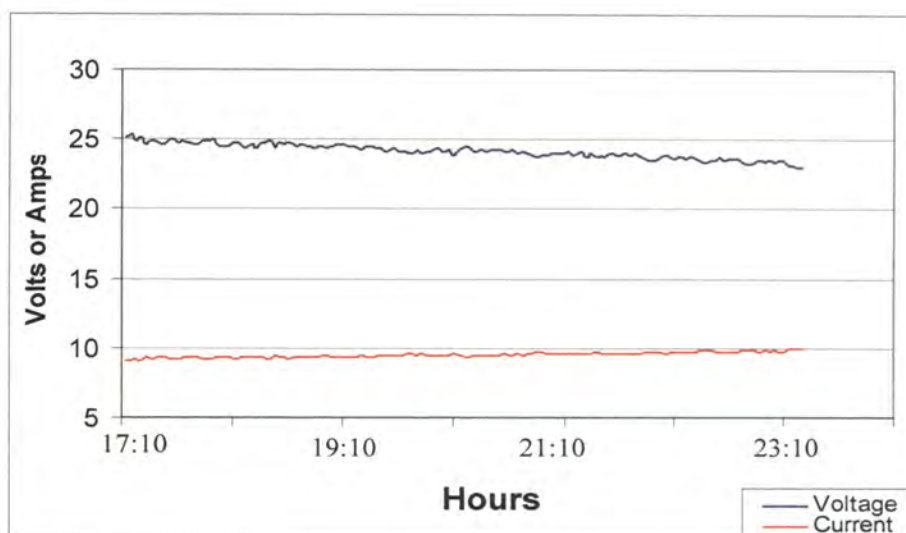

Figure 5.9. Calculated DC Current from the Batteries to the Load on December 2, 2006

Figure 5.10 shows a mostly overcast day to represent the amount of energy collected without direct sunlight, and it shows that the lamp worked for just over an hour. During the day the sun broke through the clouds for less than an hour. The rest of the day the power collected between 10W and 40W, depending on the time of day. The level of cloud cover determines the current flowing into the battery. Clear skies deliver a maximum of 6.6A, where a thin layer of clouds limits the output to between 5A and 5.4A. The number of clear days in Missouri during the winter was limited to a couple of days in December, most days had cloud cover for at least part of the day, reducing the hours of lamp operation. As a battery is drained, the current rises as the voltage falls. The increase in current reduces the number of amp hours the batteries can last.

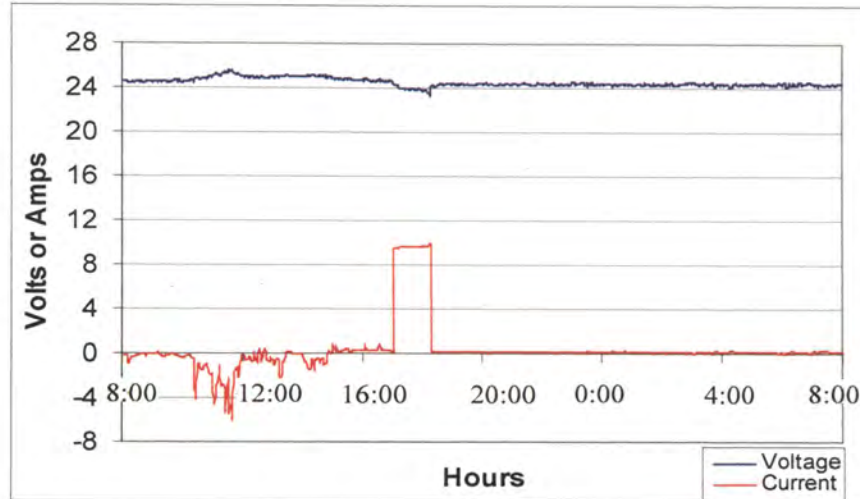

Figure 5.10. Battery Values on a Mostly Cloudy Day on November 28, 2006

The inputs of the panel are shown in Figure 5.11. This figure shows that the sun must be completely down before the voltage falls below 24V in the evening and in the morning. For December 2, 2006 the panel started at 7:00 a.m. and shut off at 5:15 p.m. The current hovers near 0.5A for about an hour before sunset and after sunrise. Table 5.3 displays an hour of operation of the HPS lamp. To determine how much current was being used during the night, the battery current was calculated to remove the variations caused by the switching of the inverter.

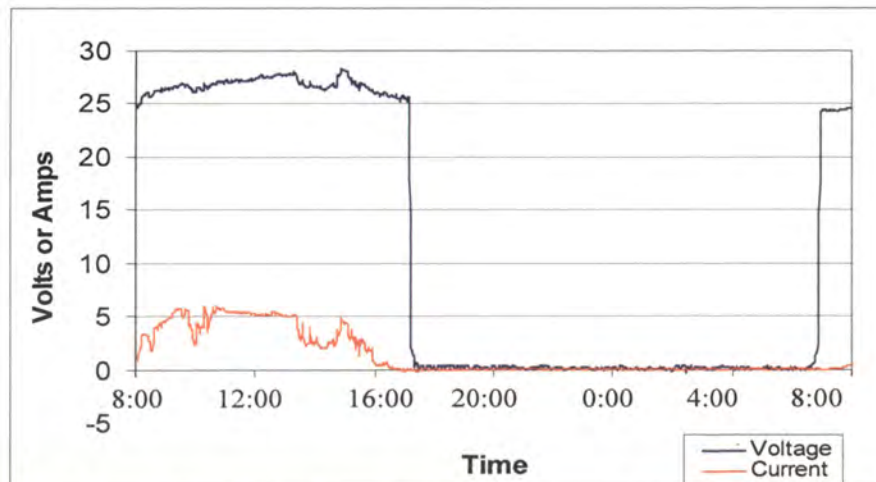

Figure 5.11. Solar Panel Voltage and Currents on December 2, 2006

To show how the system fared as the winter solstice neared, the effect on the week's worth of data showed the variations that occur constantly in the winter, as shown in Figures 5.12 and 5.13. During the eight days of the study, the results represent mostly clear days, three cloudy days, and three days of mostly cloudy skies. The best day was the December 13, 2006, with the load maxed at 5.5A and charged for under 8 hours. The lamp lasted for six hours and turned off at 11:00 a.m. The rest of the week, the lamp lasted between one hour and six hours of operation. The conclusion of this test was that under no circumstance would this prototype system provide the necessary number of days of continuous lighting to last a winter in any part of Missouri.

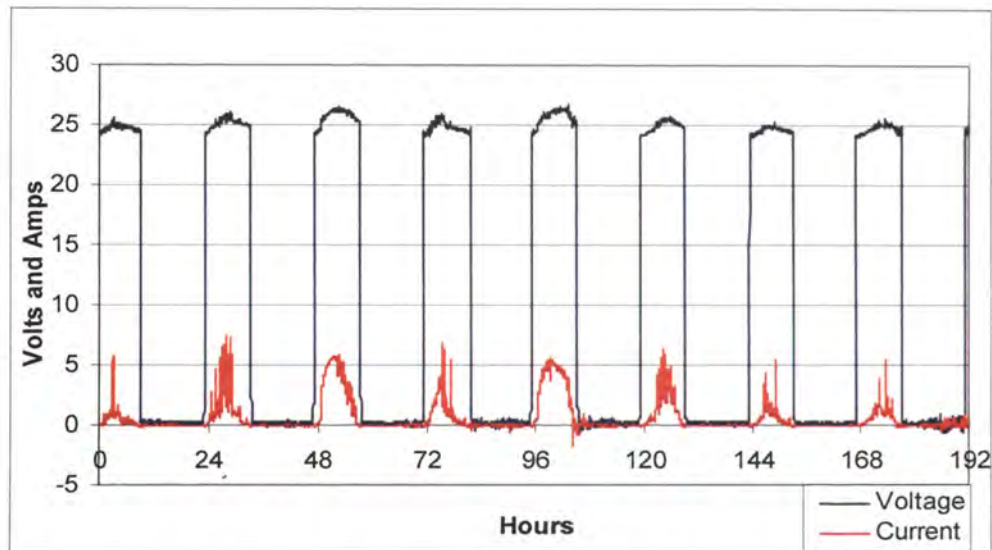

Figure 5.12. HPS Test, Panel Output the Week of December 11-18, 2006

5.3.1.2. Test two. During the first test, the weather was quite pleasant in December, compared with the temperatures experienced in January. The prototype system experienced temperatures that were below freezing for more than a week and showed no evidence that any component efficiency decreased during this period. The effects of the ice storm affected the performance of the panel by limiting the amount of light that reached the surface. The ice reflected most of the ambient light during the overcast days that preceded the storm.

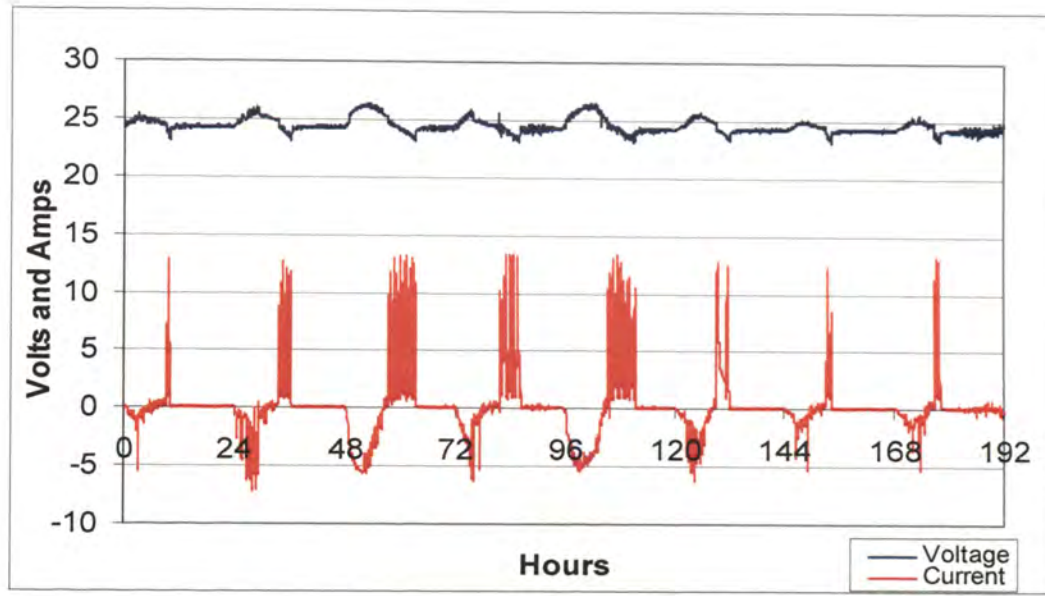

Figure 5.13. Battery Voltage and Current Measurements during December 11-18, 2006

In addition, the thickness of the ice prevented the sun from removing the ice from the panel's surface for two days, resulting in the voltage level reaching its highest reading during any of the HPS test conditions. The test results show that the number of cloudy days in January can exceed the four days of reserve battery power. The weather conditions in Missouri can vary between 6 to 21 days of overcast skies in the months of January and February [21]. The system that would be required to handle the worst case scenario would require four to five times the number of batteries and four additional solar panels to guarantee that the lamp would work throughout a four day period. This realization increases the cost to a level that decreases the chances that the project will be implemented in Missouri. Figure 5.14 shows the effects of the weather to display the lack of power collected by the panel. The MPPT prevented the lamp from working during the period after the lamp shut off on December 11, 2006 and the requirement to reestablish the load occurred five days later on December 16. During the early stages of the test, the system would collect about seven hours of power under the initial conditions. Within two weeks, the time the sun was out steadily increased providing an extra half hour of charge and delaying the startup of the lamp by 15 minutes.

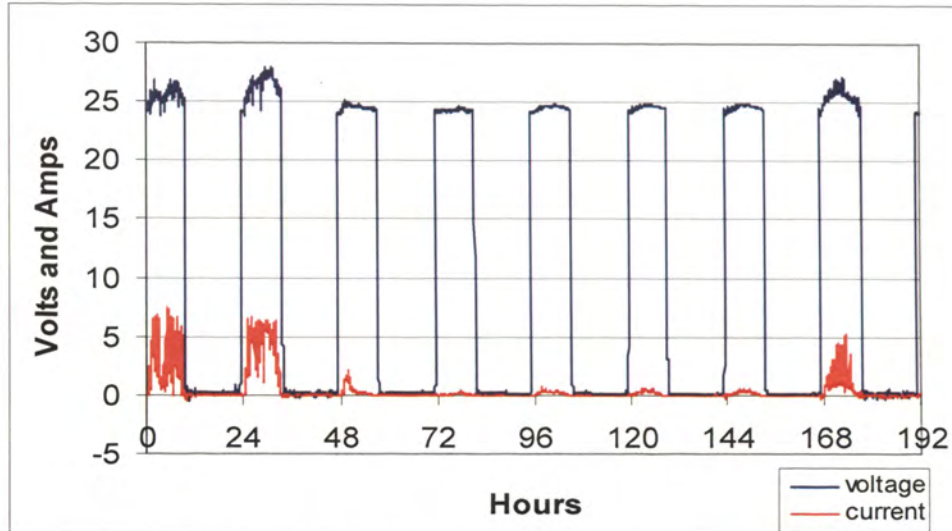

Figure 5.14. Second HPS Test Panel Values in January 9–16, 2007

The increased charging time increased the lamp's run time from shortly after midnight to past 1:00 a.m. The conditions during the winter showed that for the prototype system to survive under these conditions, a much smaller load must be used. Figure 5.15 shows the HPS lamp in action with the panel, batteries, and controller containers in the background.



Figure 5.15. The HPS Lamp in Operation

5.3.2. Test with the Light Emitting Diode. This highly efficient and expensive light was the focus of looking at a new technology that could replace current street lighting systems in the future. This test examined how the light performed with the prototype system. The light worked continuously through the night during the test. The LED light consumes 20W of power which was far less than the 230W of the HPS lamp. The advantage of using a smaller load becomes prevalent when considering the batteries. The lower the current flow, the longer the batteries can operate when comparing the total amount of power consumed. Figure 5.16 shows a period, from February 23-27, 2007, with overcast skies that prevent the panel from producing any discernable amount of energy.

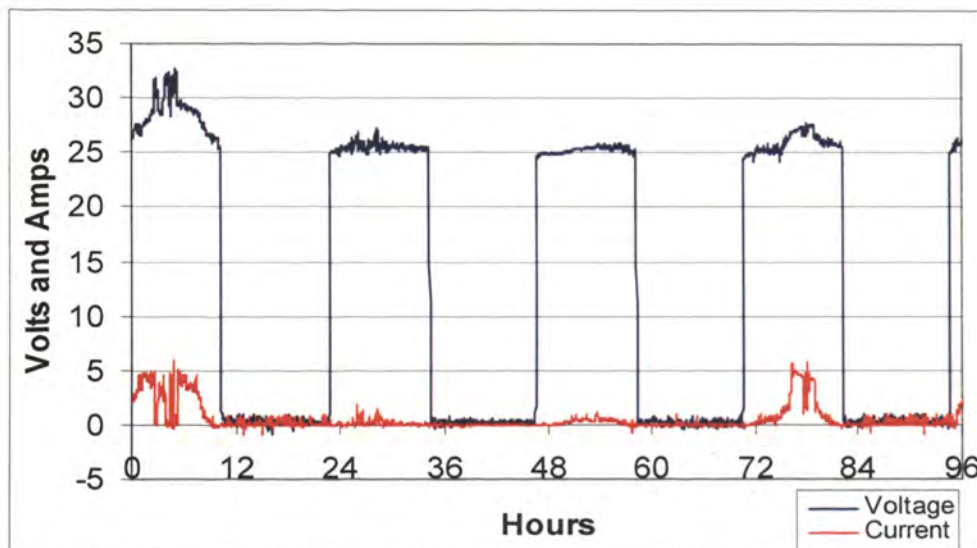

Figure 5.16. LED Test Results of the Panel, Two Consecutive Days of Overcast Skies

During this time period, the lamp continued to operate. The results in Figure 5.17 show the lamp had adequate reserves to carry the light through and had enough reserves to handle at least one more day of poor solar insolation conditions before the reserves would have been exhausted. The main drawback to using the LED was that the light put out 1,200 lumens, which was far below what the 9,500 lumens of the HPS produces. The purchasing price of the LED was considerably higher than the HPS lamp. The light from

the LED was 50% brighter directly beneath the light compared with the HPS. The design of the lamp uses hundreds of light emitting diodes directed to focus the light directly beneath the lamp; this limited the area illuminated by the light. Moving four feet away from the center of the LED light, the foot-candle measurements fell to near zero. The most notable difference between the two lights was that the LED light had no discernable color and the light was aesthetically pleasing and produced only a small amount of light pollution. The HPS light covered a much larger area with its orange glow, but a portion of the light was wasted upward. The future of LED lighting will steadily improve in the next few decades to be comparable with the HPS and with increases in utilities rates, the demand for energy efficient lighting will continue to grow. Figure 5.17 occurred during a four days period, from February 23-27, 2007.

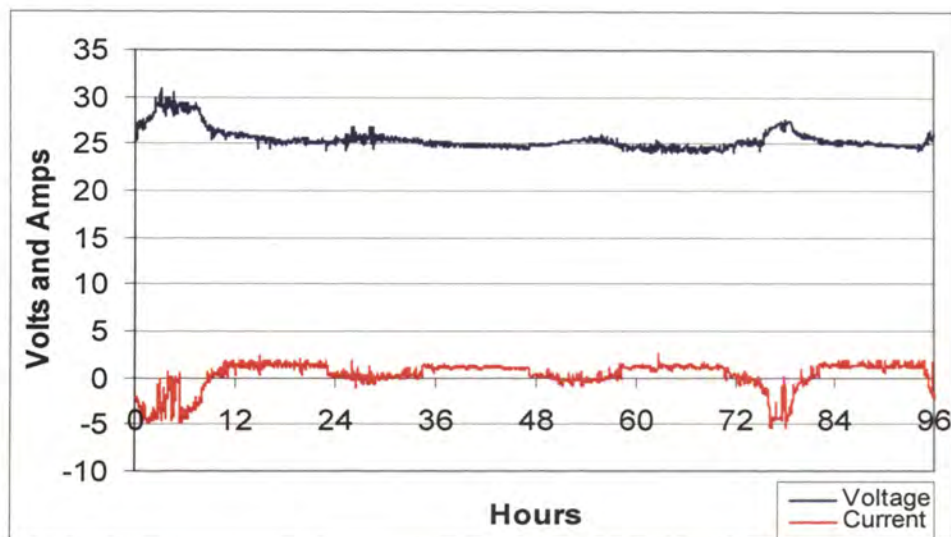

Figure 5.17. LED Test, Battery Results Show Lamp Operating during Overcast Period

5.3.3. Test with Fluorescent Lighting. This test was to investigate how the prototype system would work with a load that ran 24 hours a day. The load selected for this test was a standard 4-foot fluorescent light that was within the tolerance range of the system. This lamp used two fluorescent tubes lights that consumed 64W; a load above 100W would drain the batteries too quickly before a pattern could be discerned. To

increase the accuracy of the results, the system was given one night off to build the batteries reserves. The lamp was turned on shortly before the photovoltaic panel shut off on February 14, 2007. The results of the test are shown in Figure 5.18. The weather conditions for this test were a mix of mostly clear to completely cloudy skies with a temperature range of 6°F to 32°F. The test shows that when the skies were clear with limited amounts of clouds, the system had enough energy to supply the light and the batteries. The weather conditions on February 15 became increasingly cloudy, over the next two days the amount of energy to the batteries was diminished; the lack of reserves caused the MPPT to disconnect the lamp at 2 a.m. The skies on February 17 were completely overcast, but the panel provided enough voltage to have the MPPT reconnect the load a few hours after sunrise. The amount of power required by the load was more than the panel could provide so the batteries were drained past the preset shutoff of the MPPT. The moment the panel was no longer operating, the lamp was turned off.

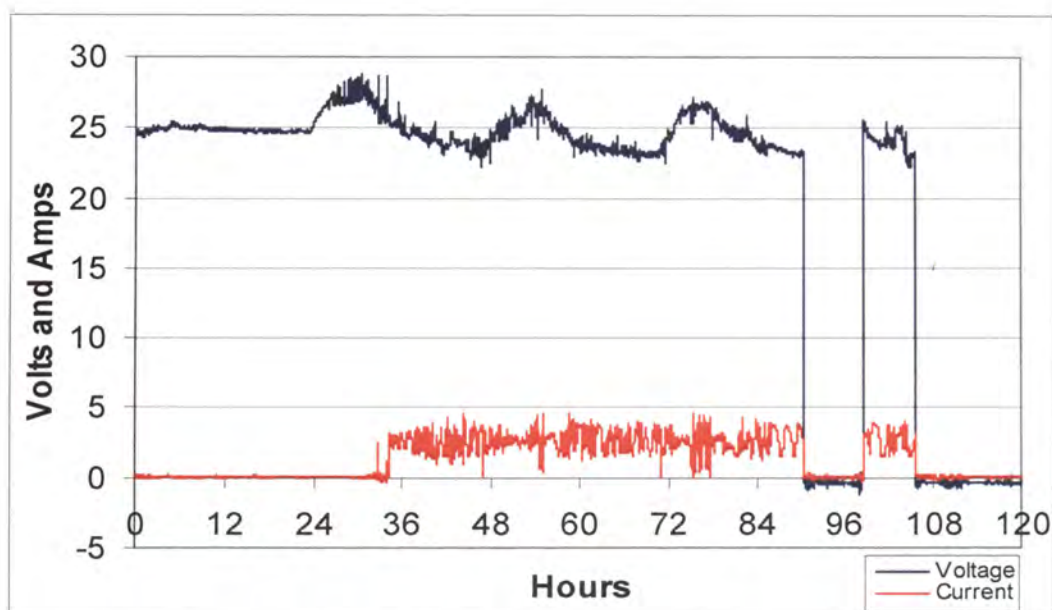

Figure 5.18. Fluorescent Light Test Results on Load Side on February 13-17, 2007

The effect the light had on the batteries during sunny days was during the two hours after sunrise and before sunset. The lamp used all the power from the panel

preventing the batteries from recharging and if the power drops due to a cloud the batteries supplied the remainder to the lamp. Had the lamp had continued to run for another overcast day, the batteries could have been severely damaged if the level of charge had reach maximum entropy. The conclusion of this test is that the prototype system can handle loads during the day, but needs to be redesigned to monitor the batteries' health to prevent long term damage. Figure 5.19 shows the energy that reached the batteries and the power consumed by the load.

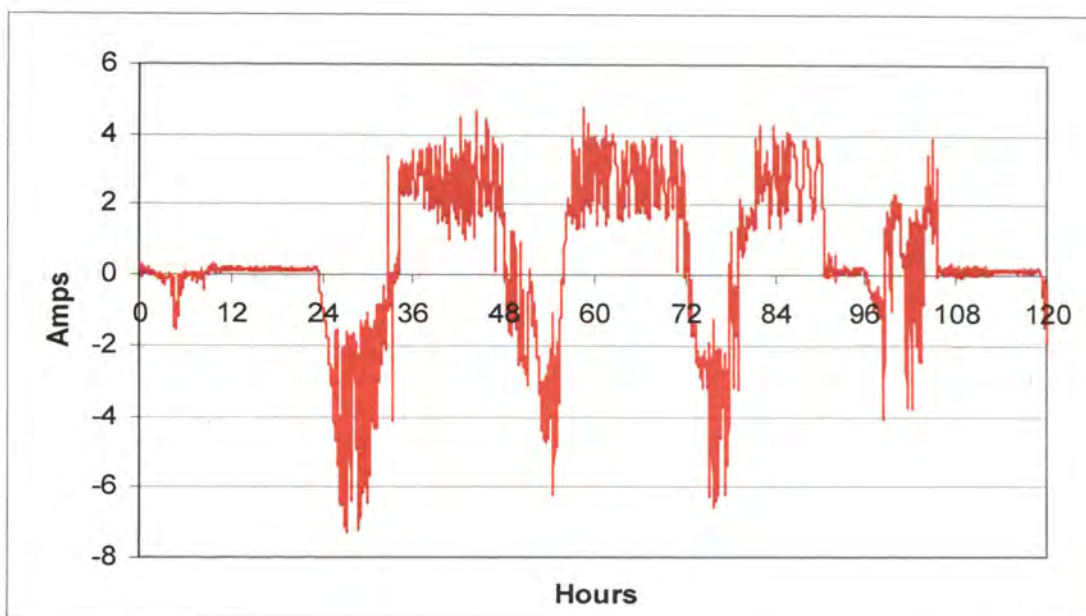

Figure 5.19. Effect Fluorescent Light had on the Batteries' Ability to Recharge

5.3.4. Secondary Test. During the course of designing the prototype system, a timing device was considered as a way of reducing the number of hours the lamp would be in operation. The device turned the lamp off during hours of the night when traffic was light. The weather for this day was mostly clear with thin clouds, with a day of reserve energy of about an hour from the previous overcast day. The lamp would last for eight hours after sundown under the conditions of a clear day. For this test, a period of three hours was selected for the lamp to be off. The test showed that the battery voltage

was up 0.2V when the lamp was turned back on. The data illustrated the break allowed the batteries to redistribute the electrons and added a half hour of time to the test. The lamp would have been disconnected if not for the extra time that it had collected. The results of the test show that a timing device would improve the efficiency of the prototype, but the increased time the lamp would run still was not enough for the system to store reserve energy. Figure 20 illustrates the voltage and current measurements during the test with the current drop off at midnight and reconnected at 3 a.m.

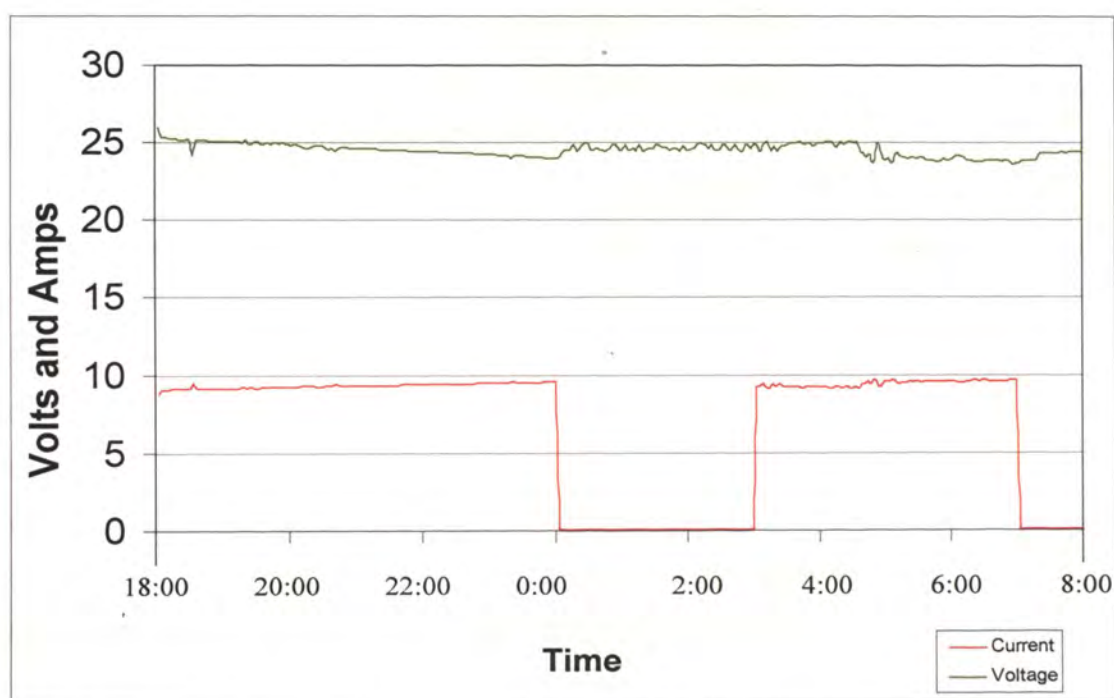

Figure 5.20. Timer Test on February 6, 2007 with 3 Hours Down Time for HPS Lamp

6. PROJECT SIMULATIONS

6.1. SIMULATION PROGRAM

The abilities of the project were limited to only a few loads on which to collect real data. Testing other applications to determine how different panels or batteries would perform required computer simulations. The simulation results expanded the scope of this project and improved the understanding of how all the components work together. Real data from the tests were compared with the results of the simulation to verify that the outcomes were comparable. The program tested multiple setups that could be used in this project to calculate how each piece of equipment worked and produced graphs that forecast the outcome of the combined system.

6.1.1. Hybrid2. The University of Massachusetts and its Renewable Energy Research Laboratory developed a simulator for the U.S. Department of Energy to calculate the different forms of hybrid power systems available to the public [39]. The program, Hybrid2, was used to simulate different types of equipment configurations, and it generated results that showed how a prototype system would be able to handle a desired load. The program was designed to simulate all forms of power generation including hydro, wind, solar, and generators with AC or DC loads. Each section of the program demanded a great amount of the manufacturer's information on all aspects of the simulation, as shown in Figure 6.1. The program results provided a realistic model that performed detailed long-term systems performance and economic analysis. The layout of the program enabled user-friendly programming and analysis of any type of load or power supply [39]. The flexibility of Hybrid2 allowed the user to add different pieces of equipment, and it used time series data to model the solar insolation, ambient temperature, and the primary AC load. Use of real time data increased the effectiveness of the simulations by focusing on the weather conditions for the area of study.

6.1.2. Solar Insolation and Temperature Values. The data used in the simulations came from the National Solar Radiation Data Base [40]. Data collected from 1961 through 1990 were available to the public, and more recent data were for sale. For the test conducted for this project, solar insolation values from the 1980s were used to

test different years of varying weather conditions. The ambient temperature provided the daily high and low for St. Louis from 2000 to 2006 [41]. The simulations provided the hourly values of the watt hours per square meter ($W\text{-h}/m^2$) to build the pattern [39].

PV Array Module Description		Tracking Options	
GEPV - 165		<input checked="" type="radio"/> Fixed Slope <input type="radio"/> Horiz E/W Daily Adjustment <input type="radio"/> Horizontal E/W Tracking <input type="radio"/> Horizontal N/S Tracking <input type="radio"/> Tilted N/S Tracking <input type="radio"/> Two Axis Tracking	
# of PV Modules In Parallel	1	Peak Voltage = 25.0 [V]	
# of PV Modules In Series	1	Peak Power = 0.17 [kWp]	
PV Array Efficiency (%)	95	MPPT	
Rack/Tracker Cap Cost (\$)	0	<input checked="" type="radio"/> Yes	
Array Installation Cost (\$)	0	<input type="radio"/> No	
		MPPT Efficiency (%)	95
		Cost of MPPT (\$)	0
		PV Array Slope (deg)	35
		PV Array Azimuth (deg)	0

DC PV Module Description		Input Units	
GEPV - 165		<input checked="" type="radio"/> Metric <input type="radio"/> English	
		View Graphics...	
PV Module Temp SRC (degC)	25	PV Module Area (m ²)	1.44008
Solar Insolation SRC (W/m ²)	1000	Isc Temp Coef (1/degC)	0.003
Short Circuit Current, Isc (A)	7.4	Capital Cost (\$)	800
Open Circuit Voltage, Voc [V]	32	Useful Life (yr)	30
Max. Power Point Voltage [V]	25	Voc Temp Coeff (V/degC)	-0.13
Max. Power Point Current [A]	6.6	Cell Material Band Gap (eV)	1.12
Number Cells in Series	54	Ambient Temp NOC (degC)	20
		Solar Insolation NOC (W/m ²)	800
		PV Module Temp NOC (degC)	45

Figure 6.1. Photovoltaic Values for a GE 165W Panel

The plot in Figure 6.2 demonstrates the rising and falling solar insolation values in December 1989. The setup for the ambient temperature and for the AC load was incorporated into the program the same way as the solar insolation page. From this information, the load files were built using the hours when the sun was down for the time the light was on. When matching the real results with the results from Hybrid2, the weather during the experiment was documented and a similar year was used for comparison. The solar insolation data were used to determine how a system would operate in the best and worst recorded weather conditions. In a few tests, the values from Phoenix, Arizona were used and the results were compared with the values from St. Louis, Missouri.

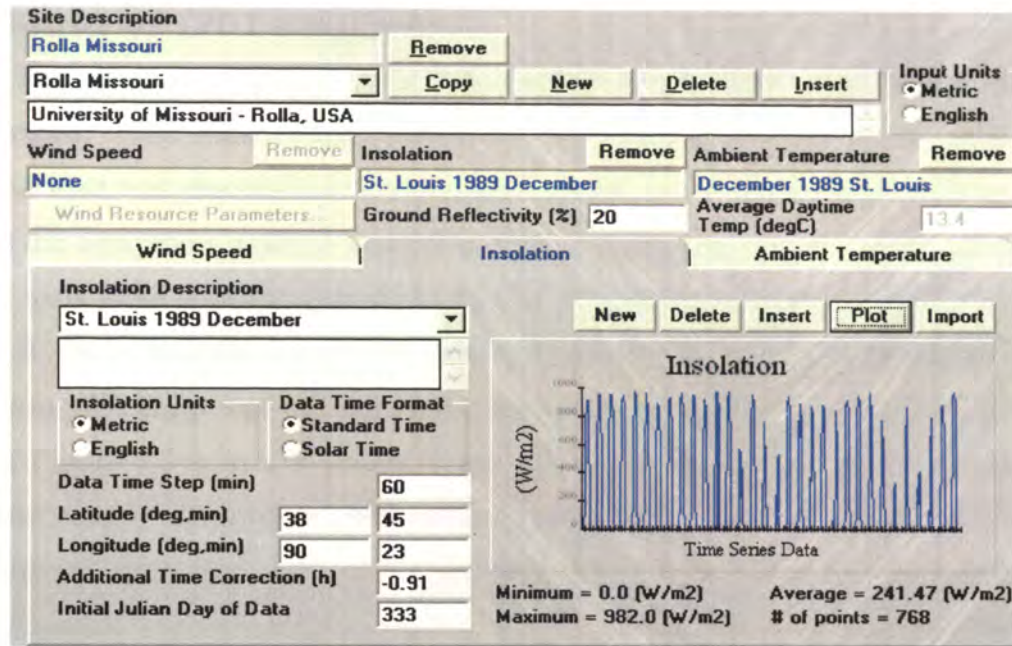

Figure 6.2. Solar Insolation Values for St. Louis in December 1989

6.1.3. Simulation Standards. Simulating four different loads under the same operating conditions showed how each load would perform under winter conditions. The solar insolation values for St. Louis from September to December of 1990 were used for the majority of the tests. The simulations used a 165W GE or 200W GE solar panel mounted at an angle of 38 degrees. The panel was connected to an MPPT and two series connected Surrrette HT-8D batteries. For the AC loads, a 900W inverter was connected to the load outputs on the MPPT. To maximize the energy collected by the panel in the winter, the angle of the panel could be adjusted to 42 degrees; this adjustment increases energy storage by half a percent but greatly decreases the system's ability to charge in the summer months. The optimum year-round angle was near 30 degrees for this region of the country. For the simulation, the angle was set to 38 degrees to generate more energy in the winter months. The simulations included power usage of the inverter, the MPPT, and the lamp system. In all the simulations, the batteries stored only 80% of the maximum power that the panel could provide during optimal conditions due to losses in charging.

6.2. HYBRID2 OUTPUT ANALYSIS

The amount of information provided by the program was broken down into preset graphs. The most useful results for determining how long the lamp operated before the load was disconnected were the Primary AC and Unmet load. The test done involved the equipment used in the project to demonstrate the effectiveness of the design. The first tests were simulated using values for St. Louis, Missouri. This result, shown in Figure 6.3, shows the amount of time the bulb operated shown by the constant line of x's and the time the lamp was off before the intended time shown by the triangle line. The layout of Figure 6.3 is in kW versus hours. This simulation tested a 200W panel during the second week in December 1990 using a 200W HPS lamp. The simulation represents the number of hours the lamp was in operation and the total number of nighttime hours. The results show the performance of the system operated for a limited number of hours. The best night during this period of time worked for six hours and was out for the remaining eight hours. Figure 6.3 shows a portion of a simulation using a HPS lamp with 2256 hours into the simulation, representing midnight on December 3, and 2422 representing midnight on December 10.

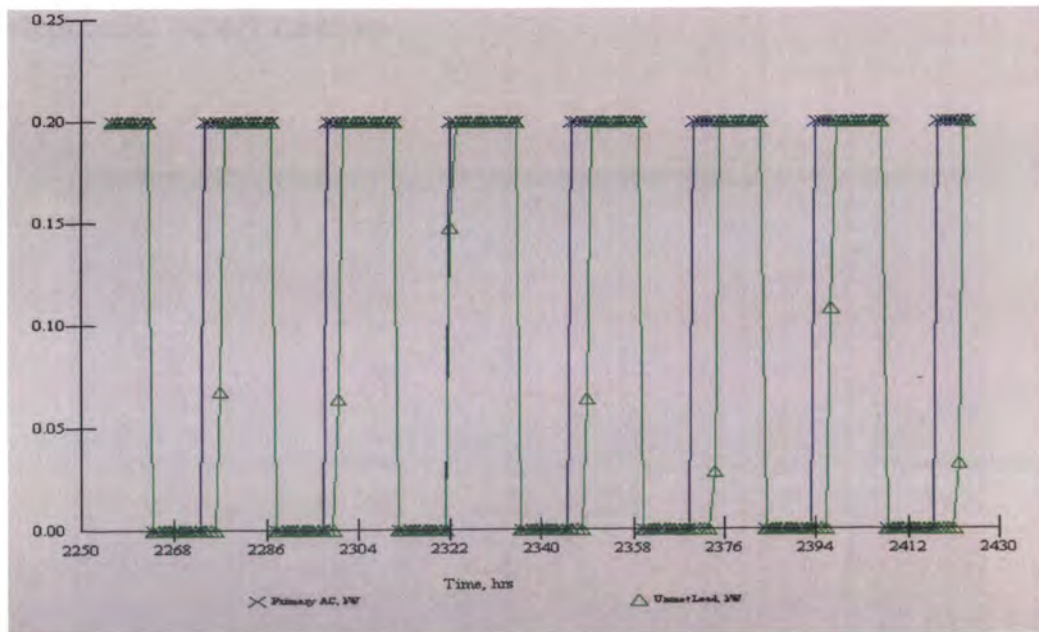

Figure 6.3. Weeklong Simulation Showing the Primary AC Load, and Unmet Load

The representation of the amount of energy reaching the panel and the outgoing power provides a way of examining the effects of a week of cloudy skies on the load. Figure 6.4 shows the amount of power fed into and out of the batteries in kilowatts. The test used a 20W LED light to show the system's ability to handle consecutive days of overcast skies. The batteries were 80% charged prior to this two-week period. The effects of the poor conditions eventually drained the batteries and caused the lamp to not make it through the night. The primary graph used to determine the effectiveness of the equipment under testing was the battery energy storage in amp hours (Ah). The parameters for Figure 6.4 used the 20W LED lamp with a 165W panel during the last two weeks in November 1989. The x's represent the input power from the panel in kW, and the triangles the power used by the lamp during the night. The weather conditions for this week provided limited power to the prototype, but the battery reserve keeps the lamp operating through the majority of the two week period. Figure 6.4 shows a portion of a simulation using a LED lamp with 1848 hours into the simulation, representing midnight on November 16, 1989 and hour the of 2184 representing midnight two weeks later. The twelfth night was cut short due to the fact that the reserves were depleted by the preceding period of overcast skies and the two days of marginal energy storage. The purpose of the simulation was to determine what conditions had to occur for the LED lamp to deplete its battery reserves.

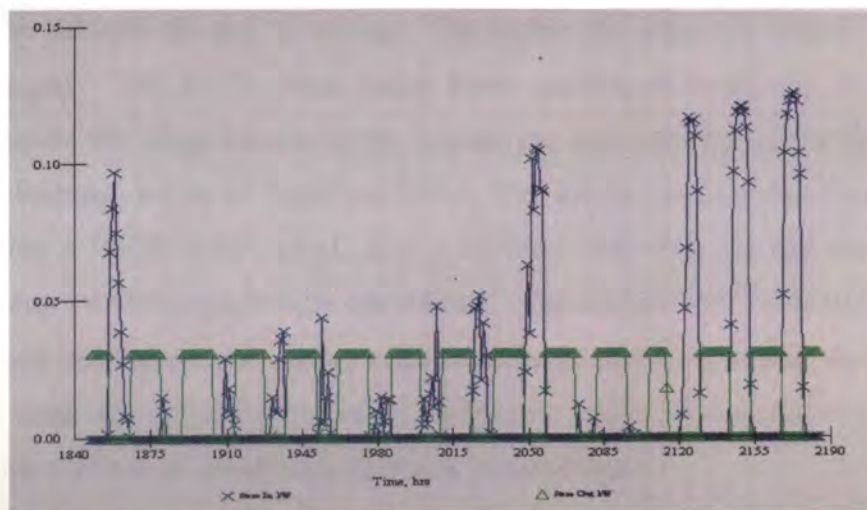

Figure 6.4. LED Test, Energy Stored In and Out of the Batteries in kW

6.3. HYBRID2 TEST RESULTS

The results of the simulations evaluated the different variations that could be considered to design the best prototype for the project. The subtle differences in equipment help to explain how small adjustments can alter the outcome of the graph. The simulations allow for a setup to be tested in conditions that are favorable as well as a worst case scenario. The temperature and solar insolation values focused on the conditions of St. Louis in winter for three different years: the overall best (1989), an average year (1990), and a season of mostly cloudy skies (1983). Each year was used in determining how each light load worked under those conditions. Designing for the worst case scenario was above the realm of the project's scope and would increase the cost beyond the economic value of using a stand-alone system. The best option for designing the system was to use the average results and increase the storage capacity by 20% to guard against a below-average year. The lamps chosen for the simulations were a low-efficiency HPS lamp, a high-efficiency HPS lamp, an LPS lamp, and an LED lamp. Comparisons between two different locations produced outcomes that determine where the design works and under what conditions a problem might arise.

6.3.1. Simulations with High Pressure Sodium Lamp. The first prototype tested was done with the 100W prototype HPS Cooper lamp. The lower efficiency of the ballast increased the amount of energy needed to operate the light to 220W. Figure 6.5 displays the amount of energy the battery used and received on a daily basis during September to October 1990. This simulation examines the amount of energy going into and out of the batteries for any given day. The higher the spike, the longer the lamp runs during the night. The 165W panel under these conditions would not provide enough power to operate the lamp for one night. Under the best conditions, the lamp lasted for eight of the fourteen hours of nighttime hours. The results showed that the load was too large for even a 200W solar panel, and it elevated the need for the use of a higher efficiency lamp for the project to be considered. The use of four 200W panels and eight batteries could not handle the energy requirements of this load during the winter. The test made it clear that the efficiency of all equipment had to be considered for the project to have the capabilities to handle the changing environment.

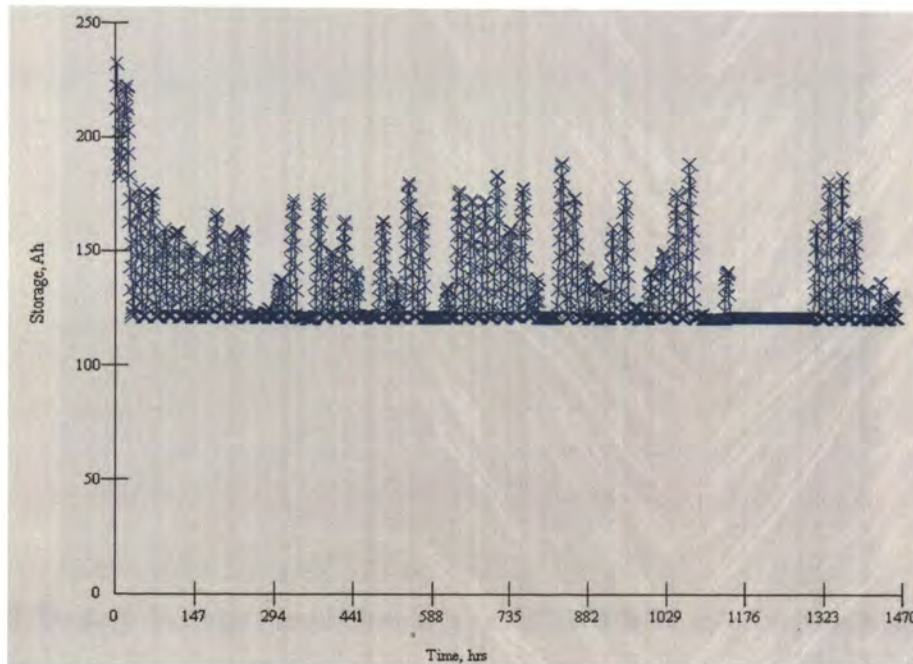

Figure 6.5. Battery Energy Reserves of Prototype System, September to October 1990

The next phase was to incorporate a high-efficiency 100W HPS lamp with an N-type ballast that used 130W to determine if an HPS lamp had the potential to operate in St. Louis. The lamp was tested during the fall months to assess the performance as shown in Figure 6.6. The amount of time the lamp operated fell as winter approached, and the ability to build up reserve power never occurred. The number of days of optimal solar insolation averaged seven per month, making any load above 40W impractical. The most noticeable difference between Figures 6.5 and 6.6 was the time it took the higher efficiency lamp to use up its reserve energy. Under ideal conditions the lamp would have operated for nine of the fourteen nighttime hours. The use of a 200W panel increased the operation of the lamp by three hours, thus the best conditions for St. Louis still are not ideal for the most efficient HPS lamp. The simulations showed that the solar insolation values were not high enough to sustain the load without doubling the equipment required for the prototype. If the necessary four days of reserve were provided, then the batteries could handle the load. However, the weather conditions prevented the panel from building a reserve for later usage.

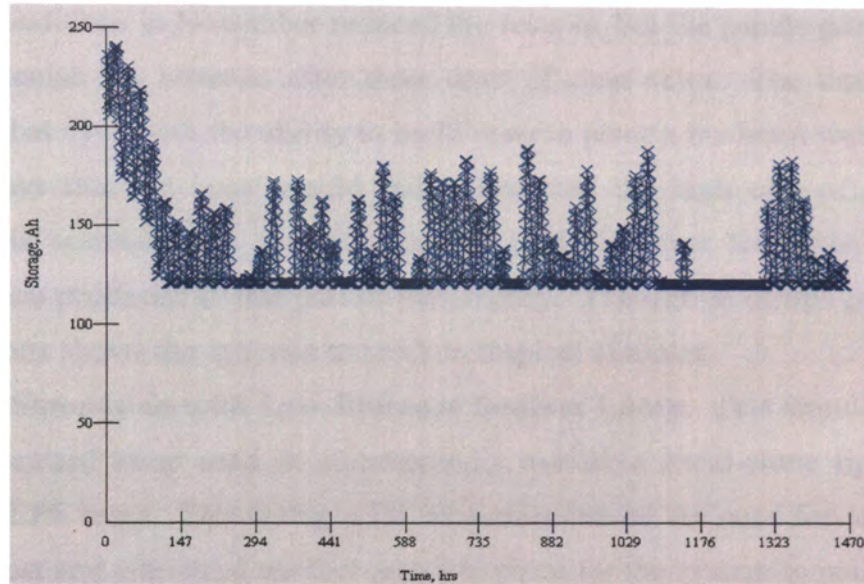

Figure 6.6. Battery Storage Simulation using a 130W HPS Lamp, September to October

For this load to operate all night in the winter, the simulation showed that the system would require four 200W panels and eight batteries. This setup would fully charge the batteries with four days of reserve power as shown in Figure 6.7. The simulation show that the best scenario works from September to December 1990.

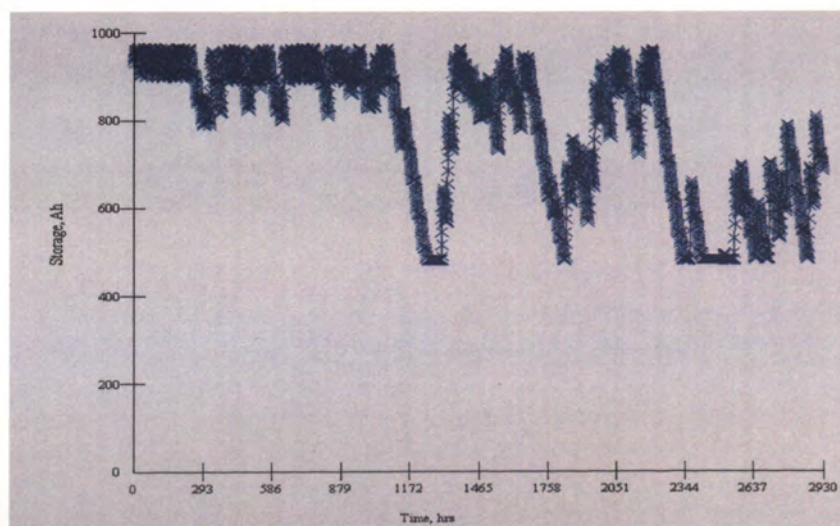

Figure 6.7. Best Scenario for the High-Efficiency HPS Lamp, Ah/Time

The conditions in November reduced the reserve, but the panels generated enough power to replenish the batteries after three days of clear skies. The limitations of the system were that even with the ability to build reserve power; the lamp would still have a number of days that the lamp would fail. However, the high cost of such a design eliminated this scenario and showed that the load size was too great for the solar insolation levels produced in this part of the country. The design of this prototype under better conditions shows the aptitude to work in tropical climates.

6.3.2. Simulation with Low Pressure Sodium Lamp. This simulation was used to test the standard lamp used in commercially available stand-alone lighting systems using a 55W LPS lamp. Simulating a DC system removed the need for an inverter; this reduced the cost and alleviated another possible place for the system to malfunction. The 55W lamp outputs 7,000 lumens, which was lower than the 9,500 lumens that the 100W HPS produced, but the need for a smaller load helped improve the design of the prototype. The HPS graphs illustrated that the problem in the original design was its limited ability to build a reserve of power to handle cloudy days. Figure 6.8 shows the results of the performance of the LPS lamp for September to December of 1990.

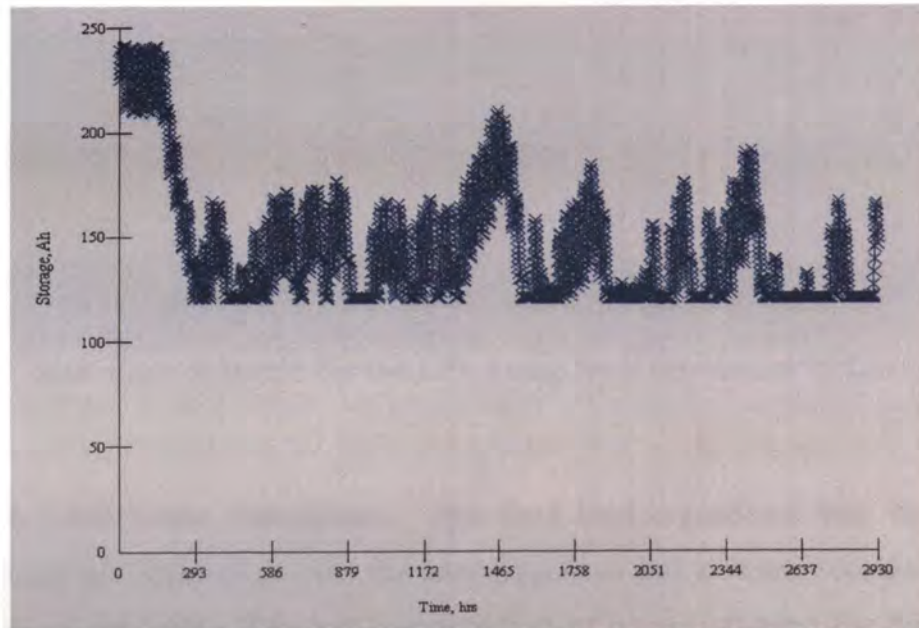

Figure 6.8. LPS with 200W Solar Panel Simulated from September to December 1990

The test of the LPS lamp showed promise in its ability to build a reserve, but the conditions of an average year still did not produce favorable outcomes for the lamp to be used in areas of prominent importance. The original calculations for the project determined that a 200W solar panel would provide the necessary power to run the 55W LPS lamp throughout the year. The panel size was calculated using the basic solar panel sizing sheet shown in Appendix C, and the use of Hybrid2 came after the prototype was built. Figure 6.9 shows that the weather conditions had a larger effect on the prototype than was previously considered. The system did have the capability to handle four consecutive days of cloudy conditions when the batteries were fully charged. The system operated effectively when the simulation was set for two 165W panels with four Surrrette batteries.

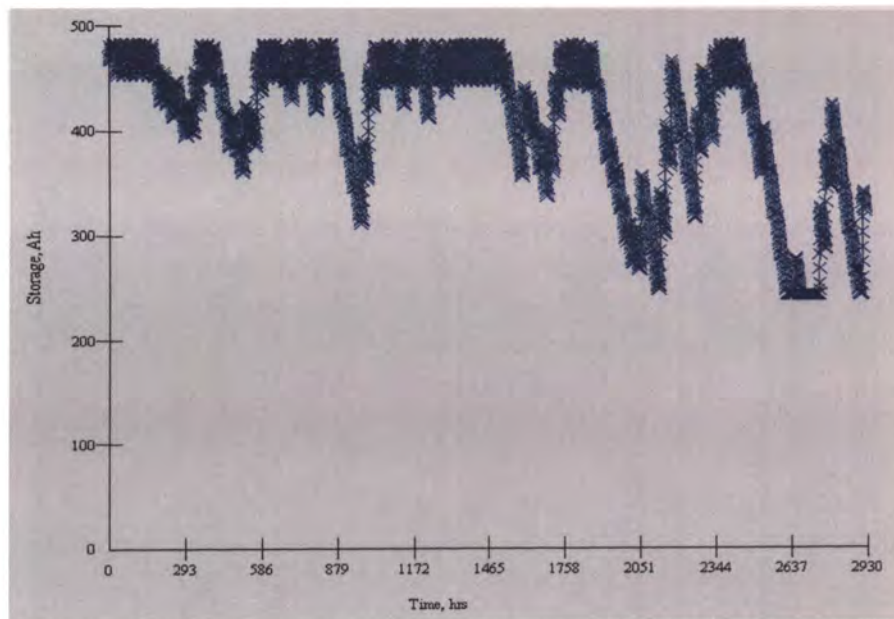

Figure 6.9. Best-Case Scenario for the LPS Lamp from September to December 1990

6.3.3. LED Light Simulation. The final load considered was the 20W LED lamp, which mainly focused on how the changing from fall to winter conditions affected the operation of the light. The low consumption of power allowed the light to handle conditions that caused the other lamps to fail. The simulation demonstrated that the best

scenario was to use the original setup of the 165W panel and two batteries. The combinations of the LED with the prototype system shows promise that none of the other lamps currently have. Current LED lamps have 400 individual lights that produce pure white light that generates little in the form of heat. Should LED lamps advance to the level of a 100W HPS lamp, incorporating solar energy into lighting the streets of the United States would become practical. Figure 6.10 represents how the prototype would have performed during the last four months of 1990. The prototype operated for five days of poor solar insolation before the reserves were depleted. The weather conditions in winter can prevent even the most efficient system from operating continuously. Increasing the panel size from 165W would have had little effect on the outcome of the simulation. The best scenario of all the simulations was the LED lamp, and during the real-time test confirms the results.

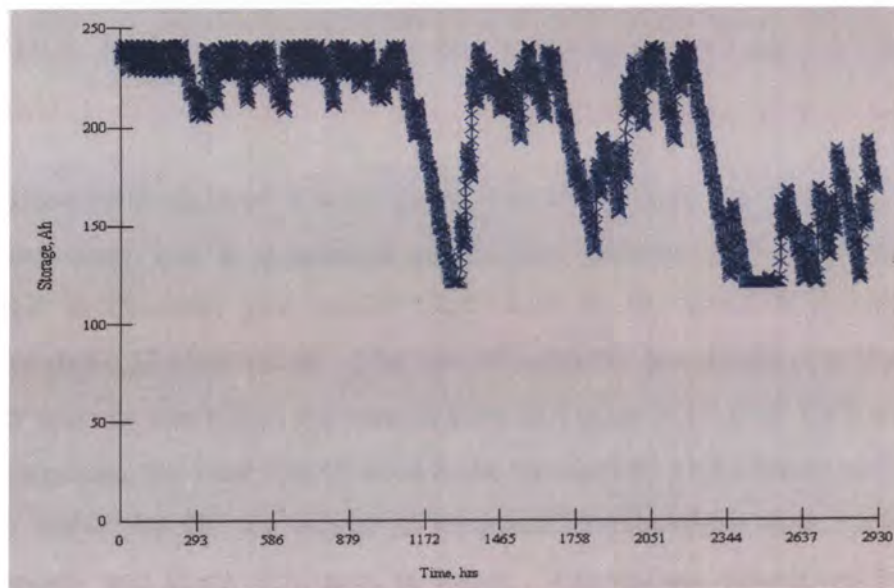

Figure 6.10. Battery Energy Reserves for the LED in Ah/Time

6.3.4. Other Test Considerations. The feasibility of the system was tested in a region that received the greatest amount of solar insolation, the Southwest United States. Simulating the high-efficiency HPS Lamp in Phoenix in December 1989 produced a nearly self-sufficient system. On days with little or no clouds, the panel provided enough

energy to power the lamp for nearly the entire night, falling just one hour short of dawn. Figure 6.11 shows the prototype system using a 165 Watt GE Panel with two HT-8D batteries in Phoenix, Arizona in December of 1989.

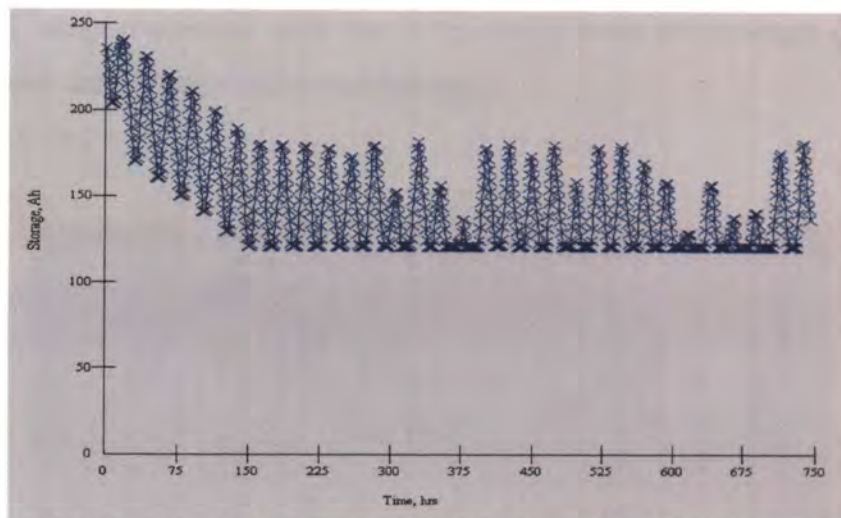

Figure 6.11. High-Efficiency HPS Lamp Used in Phoenix for 31 days in December 1989

This simulation showed that the panel was able to quickly recharge the battery on a single sunny day, but it generated no backup reserves. The system performed extremely well in Phoenix and would work well in St. Louis if weather conditions involved more days of clear skies. The use of a 200W panel added a few hours to the time the lamp was on, but it had the same effect as Figure 6.11. For HPS to be used with a stand-alone system, the load would need to be reduced to a maximum of 75W. Another consideration would be for the lamps to be placed in locations that require light from dusk till midnight and from 4:00 a.m. to dawn. The energy conserved by running the lamp for a maximum of 10 hours, instead of 14 hours, increases the number of days the lamp would function at dawn from a handful to more than 65%, and on clear days produces a small amount of reserve energy.

Figure 6.12 shows the LPS system used to demonstrate the areas where the market systems were designed to function continuously. The use of the single battery limited the number of reserve days to one, but the cost savings only prevented the lamp

from running at dawn for just seven days. The conditions in Phoenix demonstrated the effectiveness that stand-alone energy has on the capabilities to be useable as the cost of solar panels decreases and the price of electricity increases. The ideal setting for the LED system was with a 125W panel and one HT-8D battery. The reduced size of the system lowers the economic cost down a considerable amount. The cost of purchasing the more expensive LPS lamp compared with the HPS comes from the savings gained from the smaller panel and the elimination of one battery.

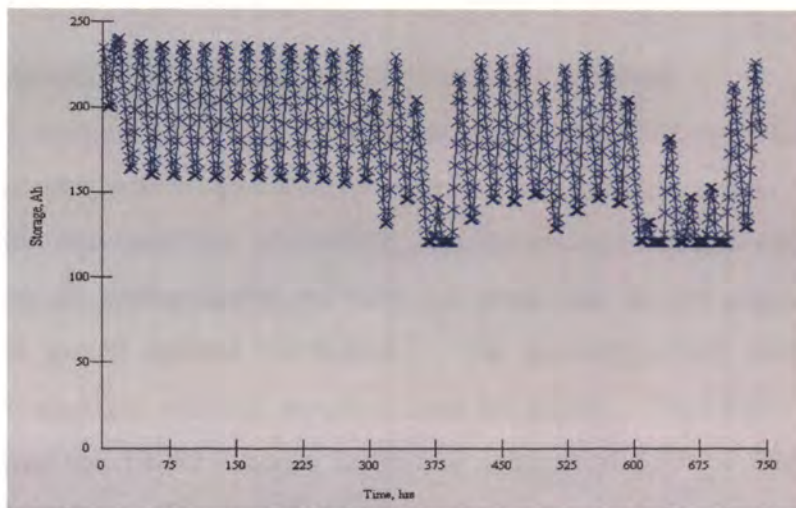

Figure 6.12. Low Pressure Sodium Lamp in Phoenix in December 1989

The overall conclusion gained from the simulation results increased the understanding of how to design a solar powered system. The use of solar insolation values for multiple years allows for analysis of how the system would perform and what would need to be done to correct any weaknesses in the design. The simulations calculated the overall best design for St. Louis, but the size and initial cost make all those design impractical. The use of the simulations allow the testing of different sized loads to determine how much wattage a prototype system could handle and fulfill the project requirements is 40W. However, remote locations are ideal for testing larger loads using new designs, with newer and higher-efficiency equipment.

7. ECONOMIC ANALYSIS

The design phase of the project focused on determining the equipment to construct the prototype lighting system. Conditions that had to be met were the four days of uninterruptible light, the output lumens, and the total cost. The design of the prototype system had to be reliable and cost effective for the project to be considered a viable source for future installation.

7.1. DESIGN CONSIDERATIONS AND COST ANALYSIS

Table 7.1 is the original parts list for the prototype. The parts list was selected to operate the lamp with a four day battery reserve. The enclosure was a metal container that could hold the two batteries, the MPPT, and the inverter. The prototype system used plastic containers as replacements to save on cost, due to the main purpose of the enclosure was to guard against vandalism. The prototype was built on the roof to provide adequate sunlight and was secured from the public. The HPS lamp was selected for the project was the 100W Cooper lamp that consumed 150W. Table 7.2 shows the parts list for the project. The 100W lamp used for the project consumed 230W, when ordered the higher efficiency lamp was phased out to promote the 150W lamp. The prototype lamp matched the lamps used on the city side streets.

For the stand-alone system to replace grid powered lights, the operational cost of the system had to meet or be below the cost of grid powered street lights. The cost to install one mile of single phase primary line was \$105,000 without lights. The average was 21 street lights per mile. The cost of electricity to power one lamp was calculated at a maximum of \$100 a year at a rate of \$0.15 per kilowatt hour. The initial cost of the grid powered light comes to about \$5,200 with the lamp. Over a twenty-year period, the estimated cost of the grid powered light comes to around \$7,200. The prototype system will require replacement of the batteries every five years. The future cost of batteries is difficult to determine due to advancements in new batteries with improved performance that will affect the estimate. Using the initial total of Table 7.2 the approximate total cost

after twenty years is below \$7,000, including an installation cost of \$2,000, six batteries, three inverters, an enclosure, a wood pole, and two MPPTs. The prototype is less than the grid powered light, but at the cost of reliable lighting. Producing the cheapest prototype came at the cost of fewer hours of operation.

Table 7.1. The Original Parts List

Worst-Case Scenario	4 Days	
Solar Panel	Price	Watts
GE 165	\$780	165 W
Batteries	Price	Amp Hrs (20)
Rolls Surrette HT-8D	\$325.16	221
Rolls Surrette HT-8D	\$325.16	221
Sodium Lamp	Price	Lumens
HPS 100W Bulb	\$13.00	9500
Enclosure	Price	Dimensions WxDxH (in)
McMaster-Carr 7561K78	\$300.81	30x12.625x36
MorningStar SunSaver 24 V	\$67.02	28.2 V Charge
24V Inverter	\$167.00	Maximum 10A
Unirac 400209	\$200.00	Panel Support
Pole Wood	\$300	40 ft pole
Lamp Bracket	\$120	100W HPS Lamp w/ bracket
Total Initial Cost	\$2,587.15	

Table 7.2 shows the actual cost incurred in purchasing the prototype system. The final cost of Table 7.1, compared with Table 7.2 shows a savings of \$900, but \$600 are from the lack of the enclosure and the pole. The rest of the savings comes from the ever-changing market fluctuations that change the equipment prices every six months. The cost of the same equipment a few years from now will be less, due to new advancements and newer models. Changes to the design that would increase the operational time of the lamp are replacement of the HPS lamp with a higher efficiency HPS lamp to reduce load by 100W, a higher wattage panel, and batteries with higher amp hour ratings. To implement the new equipment raises the total cost, the increased cost and inconsistency of winter conditions reduces the practicality of converting to the stand-alone system in town. For remote locations that need illumination, the improved prototype system provides a cost savings compared to running a line.

Table 7.2. The Prototype System Parts List

Worst Case Scenario	1.7 Days	
Solar Panel	Price	Watts
GE 165	\$719	165 W
Batteries	Price	Amp Hrs (20)
Rolls Surrette HT-8D	\$312.97	221
Rolls Surrette HT-8D	\$312.97	221
MorningStar SunSaver 24 V	\$86.10	Maximum 20A
24V Inverter	\$89.99	Maximum 10A
Unirac 400209	\$90.63	Panel Support
Pole Wood	\$300.00	40 ft pole
HPS Lamp	\$80.45	100W HPS Lamp w/ bracket
Total Initial Cost	\$1,692.11	

Table 7.3 shows improved equipment that could be used to upgrade the current prototype. The LPS bulb was the most common type used in commercial available systems. The 55W LPS lamp requires less power than the 100W HPS lamp, but was not a desirable choice due color rendering issues. The initial cost this system was higher due to the bulb and lamp assembly. Using a larger panel and batteries improves the number of days the lamp operates till dawn for the winter months.

Table 7.3. The LPS Prototype System with Calculated Equipment

Worst Case Scenario	6 Days	
Solar Panel	Price	Watts
Kyocera KC190GT	\$836	190 W
Batteries	Price	Amp Hrs (20)
Rolls Surrette 12HHG-8D	\$390.02	275
Rolls Surrette 12HHG-8D	\$390.02	275
Enclosure	Price	Dimensions WxDxH (in)
McMaster-Carr 7561K78	\$300.81	30x12.625x36
Sodium Lamp	Price	Lumens
LPS 55W Bulb	\$13.00	8000
MorningStar SunSaver 24 V	\$67.02	Maximum 10A
Unirac 400209	\$200.00	Panel Support
Pole Wood	\$300	40 ft pole
LPS Lamp	\$529	100W HPS Lamp w/ bracket
Total Initial Cost	\$3,025.87	

7.2. ECONOMIC ANALYSIS OF THE VARIOUS LIGHTING SYSTEMS

7.2.1. The HPS Prototype System. Had the results of the HPS test shown the lamp running all nightlong for the four days of inclement sky conditions, the cost of the project will make the prototype a viable option. The equipment purchased for the project shown in Table 7.4 represents the purchase price of each piece at the time of the construction. The total cost includes all the main components of the project, but does not include the protective container for the MPPT, wiring, the light pole, and the battery trays that guard against spillage. The cost of shipping was considered necessary, due to the cost associated with the transport of the solar panel and batteries. When considering the use of a solar powered system, a life-cycle cost analysis must be done to determine the future cost of parts replacement and how long it would take to produce enough power to pay for the equipment [24]. The initial startup cost for the project was over \$2,000 the maintenance costs is considered to be small for the first 5 years after installation. After that time period, the effectiveness of the inverter, MPPT, and batteries diminishes due to cost of replacing the equipment. The cost of replacing the batteries alone pushes the replacement cost of the project to over \$700, and this would have to be done every five to seven years depending on the reliability of the batteries. For the project to be considered, an alternative for street lights operation in stand-alone mode, the cost of electricity would have to be over \$400 a year for the first five years and over \$250 a year for the next five years to pay for the battery replacements. The cost savings from the electricity saved would need to be over \$1,200 a year to cover the cost of this design. If the cost to power one high-efficiency street light is \$0.15 per kW/h, and the number of hours the lamp is on is determined to be on average 12 hours a day, the yearly operational cost of each light would be less than \$100 a year.

For the assumed constraints, the overall effectiveness of this project fails as an option to replace the power grid as a source of power for the street lights. The design though was not a total loss when considered for locations that are far from the power grid. The price to run electricity to remote locations can be in the hundreds of thousands of dollars to run single phase power lines. The distance to some locations is very far

from the main power grid for the utility to run power to the buildings. The cost of building and operating the stand-alone system would be far less expensive in this setting.

Table 7.4. Cost of HPS Prototype System

HPS System		
Prototype Equipment	Price	Shipping
GE 165W Panel	\$719	\$163
Rolls Surette HT-8D	\$625.94	\$111.00
High Pressure Sodium Lamp	\$80.45	\$0.00
MorningStar SunSaver 24 V	\$86.10	\$15.21
Unirac 400209	\$90.63	\$18.64
Power Inverter	\$89.99	\$10.00
Total Initial Cost	\$1,692.11	\$317.85

7.2.2. The LED System. The LED system cost under \$2,700 to build, with the major cost increase incurred by the LED lamp. The equipment purchased for the project shown in Table 7.5 illustrates the cost in switching to the LED lamp. The ability of the system to fulfill the criteria for running for consecutive cloudy days was a success, but the lamp lacked the lumens level required for use on city streets. The long life spans of the LED lamp and solar panel are important aspects when looking at the long-term cost of a stand-alone system. The lifespan of 20 years for the solar panel and 10 years for the lamp means that the cost of operating the stand-alone system must be reevaluated to include cost of replacing the equipment. The cost of the lamp compared against the HPS looked at how often the bulbs would need replacement. It is assumed that about three new HPS bulbs would be needed over the 20-year period, compared against the one for the LED option. The replacement cost of the HPS is ten times less than the LED. The life cycle cost analysis of the stand-alone system requires long-term consideration to be taken into account that may impact the effectiveness of the study. The continuing advancements in LED lumens output must be considered every year to determine the drop in initial cost, and how much per kilowatt would make the stand-alone system feasible. The economic cost currently makes the stand-alone LED light extremely expensive in terms of dollars-per-lumen.

Table 7.5. Cost of LED Prototype System

LED System	Price	Shipping
Prototype Equipment		
GE 165W Panel	\$719	\$163
Rolls Surrette HT-8D	\$625.94	\$111.00
LED Lamp	\$725.00	\$27.80
MorningStar SunSaver 24 V	\$86.10	\$15.21
Unirac 400209	\$90.63	\$18.64
Power Inverter	\$89.99	\$10.00
Total Initial Cost	\$2,336.66	\$345.65

8. CONCLUSION

From this study, it was evident that solar energy is an impractical source of power for year-long usage for a stand-alone system to operate public streets lights for continuous nighttime operations. Analysis done for St. Louis determined that even during the most optimal years that the project would still fall short of the full power requirement for the HPS lamp. For solar insolation values to be considered favorable, the sun must not be obstructed for 80% of the day. Due to the power demands of the prototype lamp, the battery reserve was depleted in 1.7 days, instead of the calculated 3 days. The solar insolation conditions in the Midwest hampered the ability of the project panel to build a reserve of power during the winter months. Figure 8.1 reiterates the difficulty in collecting the necessary power to keep the HPS lamp operating even under sunny skies. Under the best conditions in winter, the HPS lamp was unable to operate for the entire night.

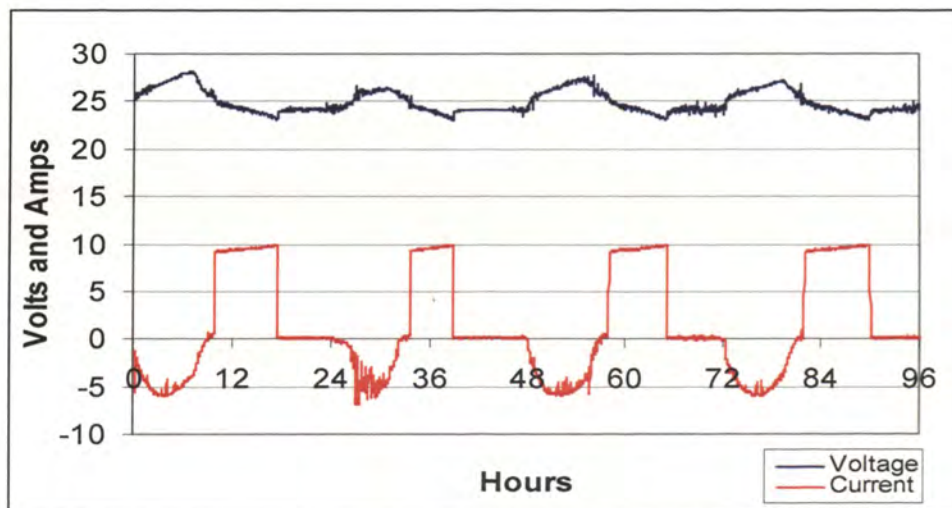

Figure 8.1. The Low-efficiency HPS Lamp during 4 Sunny Days on January 23-26, 2007

The requirement of three 200W panels and a minimum of six batteries guarantee that the lamp would work under the worst winter conditions. However, the cost of

equipment outweighs the benefits of running the lights off the grid. It is however believed that solar lighting with the HPS could still be effective for area lighting where continuous nighttime lighting is not required. The use of timers to control the amount of time the light is on increases the effectiveness of a stand-alone system. The LPS lamp does decrease the cost and equipment requirements, but the light quality is diminished, making this the worst case lighting option. The best option for future consideration is the LED lamp. When LED lamps generate the equivalent of 9,200 lumens or higher-efficiency panels are available, the judgment will not change.

The future applications and equipment upgrades for the stand-alone street lamp project. The use of the 12V HT-8D batteries would be switched out with the new 8V types of solar batteries, due to the increased cost the HT-8D and the higher amp hour ratios of the 8V. The solar panel size would be set at the highest available output power with a rating of 24V to maximize the systems' ability to harness the power and keep the system to a single panel. The next lamp to be tested should be a high-efficiency HPS. It will provide more data to assess how well the stand-alone system would perform in the adverse conditions that occurred during the test. The design of stand-alone systems used for other purposes besides street lighting when used with the LED lamp or in isolated regions far from the power grid. The future of stand-alone system in Missouri is dependent on the economic cost of operating a system in a feasible environment; and with advancements in LED technologies.

In Table 8.1, the results of the test have been broken down to illustrate the operational abilities of each test and display the effects that the weather had on each test. The outcome of the HPS test were well below the design specifications for continuous operation in the winter months. The weather reduced the effectiveness of the HPS lamp during the two tests. The number of mostly clear days in Test 1 was 12, with the average number of clear days at seven in December and January for St. Louis [21]. The only day that Test 1 did not operate was due to the snow and ice covering the panel. The conditions for Test 2 were affected greatly by the weather; the cold and ice covering the panel prevented the lamp from operating for five consecutive days. The number of cloudy days for an average January is 17 days in Missouri [21]. The skies during Test 2 were mostly cloudy for 14 out of the 23 testing days, overall a below average month.

The cold was a factor during this test due to the below freezing for a full week. The extreme cold prevented the panel from melting the ice and which prohibited the panel from generating sufficient power for the MPPT to reconnect the load. The differences between the two tests represent the best and worst conditions that the lighting system faces every winter. In Table 8.1, HPS Test 1 represents the test done in November to December 2006. Test 2 is the results of the January 2007 test. The number of nighttime hours for the LED test is lower due to the test being conducted in February.

Table 8.1. Breakdown of the Test Results

Lamps	HPS Test 1	HPS Test 2	LED
Total Days for Each Test	27	23	22
Days Operational All Night	0	0	22
Days Operational Over 6 Hours	12	6	0
Days Operational 3-6 Hours	8	3	0
Days Operational Under 3 Hours	6	5	0
No Turn On	1	9	0
	(Hours)	(Hours)	(Hours)
Average Hours of Operation	4.898	2.928	12.5
Average Nighttime Hours	13.731	13.887	12.5
Operational Hours/Nighttime Hours	0.3567	0.2109	1

These tests demonstrate the difference between 20W and 230W loads. The brighter lamp failed to operate through the night and the smaller load failed to illuminate the required area. The LED lamp performed every night of the test. The lower wattage allowed the system to last through three days of overcast skies, with the reserve power to last the required fourth day. The output lumens are still the limiting factor that prevents the lamp from being used to light up streets.

APPENDIX A.
EXPANED REAL TIME RESULTS

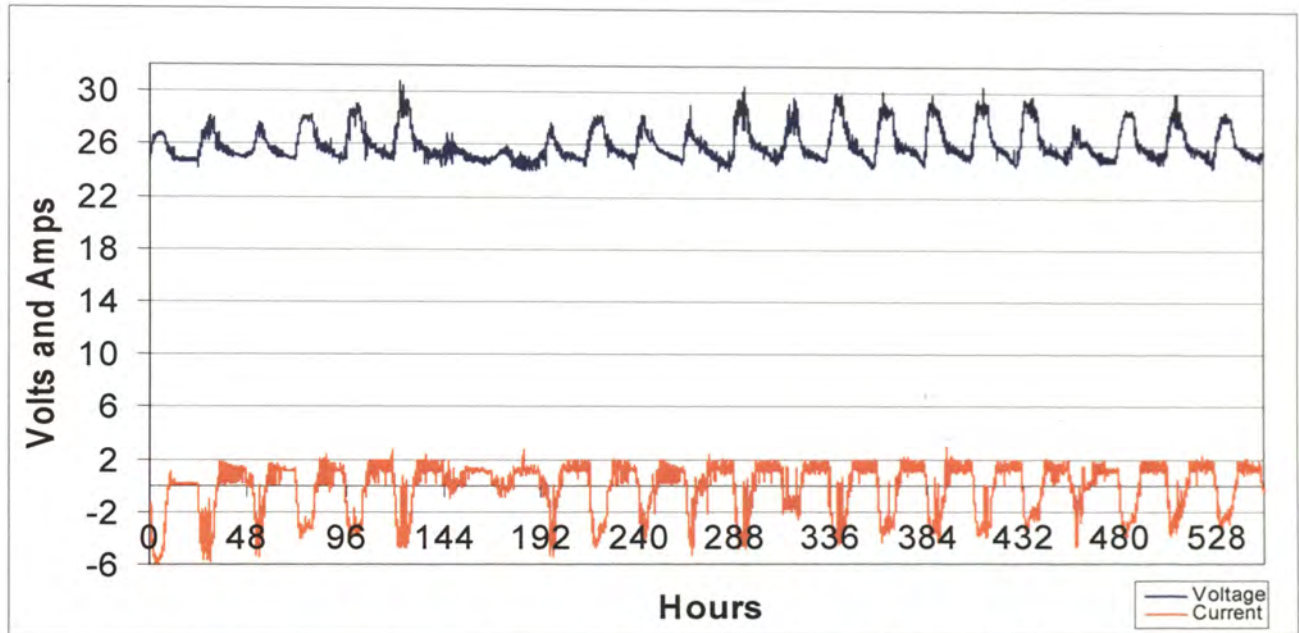

LED Test for Three Weeks. Lamp operates continuously for the duration of test. Measurements taken of the batteries, from February 18 to March 12, 2007.

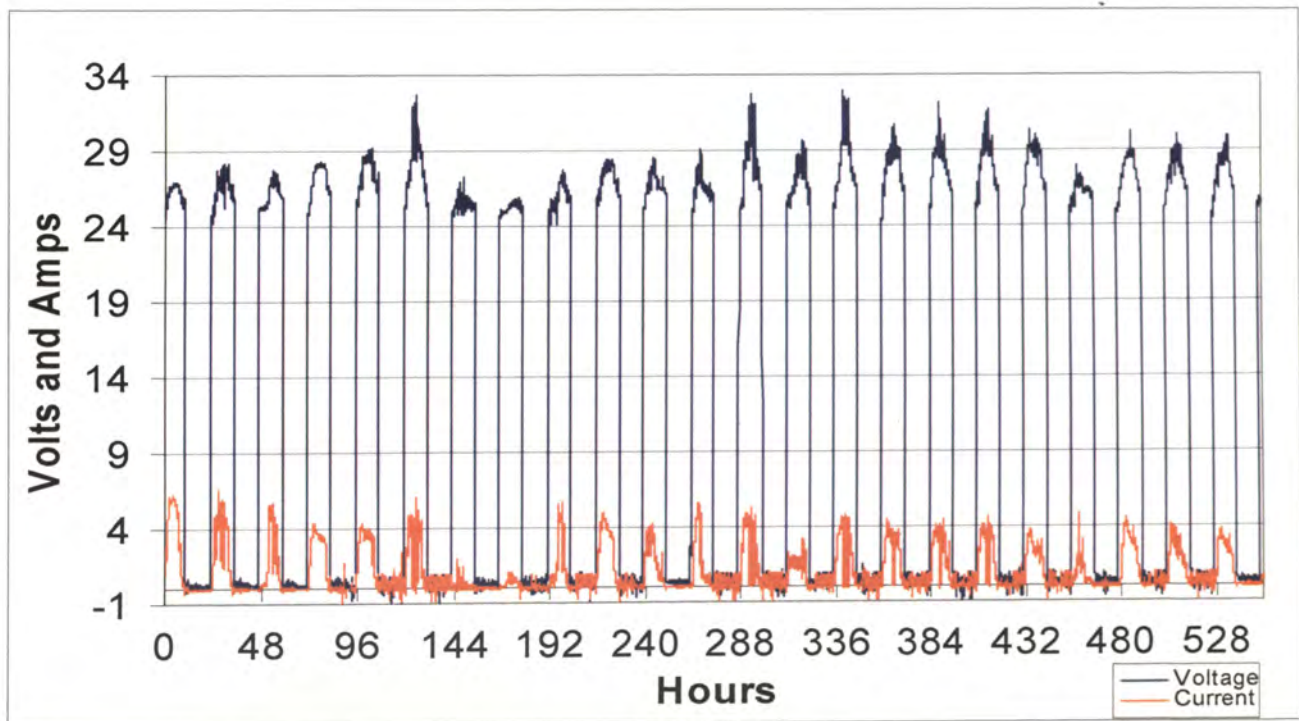

LED Test for Three Weeks. Recorded panel values, voltage spikes in graph due to panel reached the open circuit at the maximum of 32V. Tested from February 18 to March 12, 2007

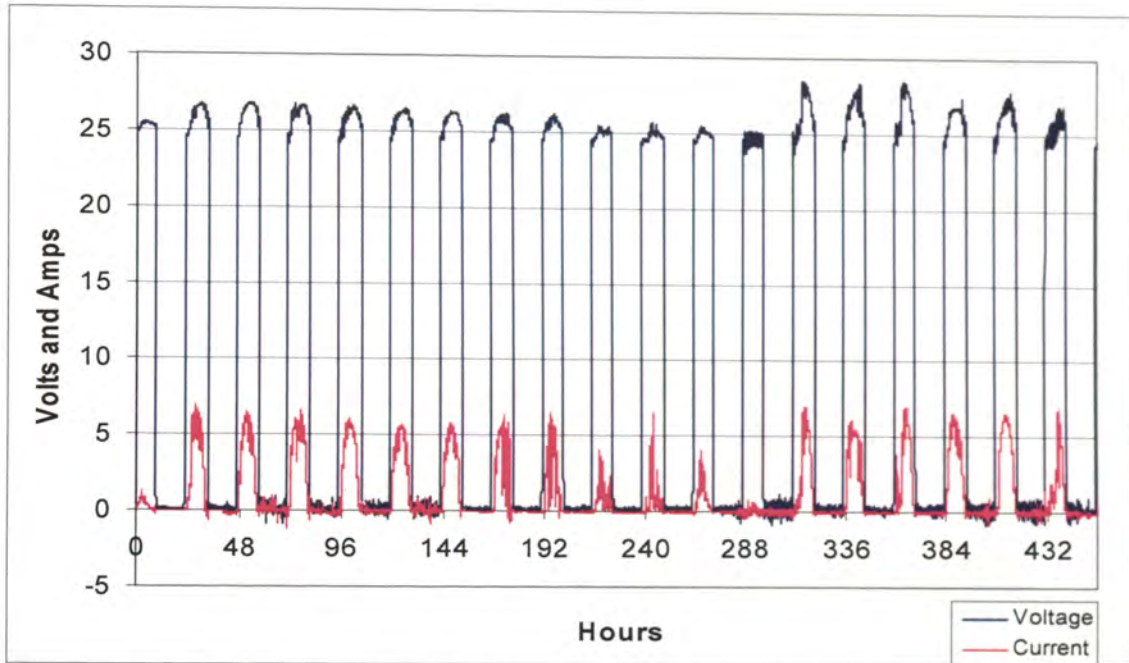

HPS Test One in 2006. Results show on sunny days the maximum voltage of the panel averaged 26.5V. Panel did not collect enough power during this period to operate lamp all night. Data collected from November 18 to December 6, 2006.

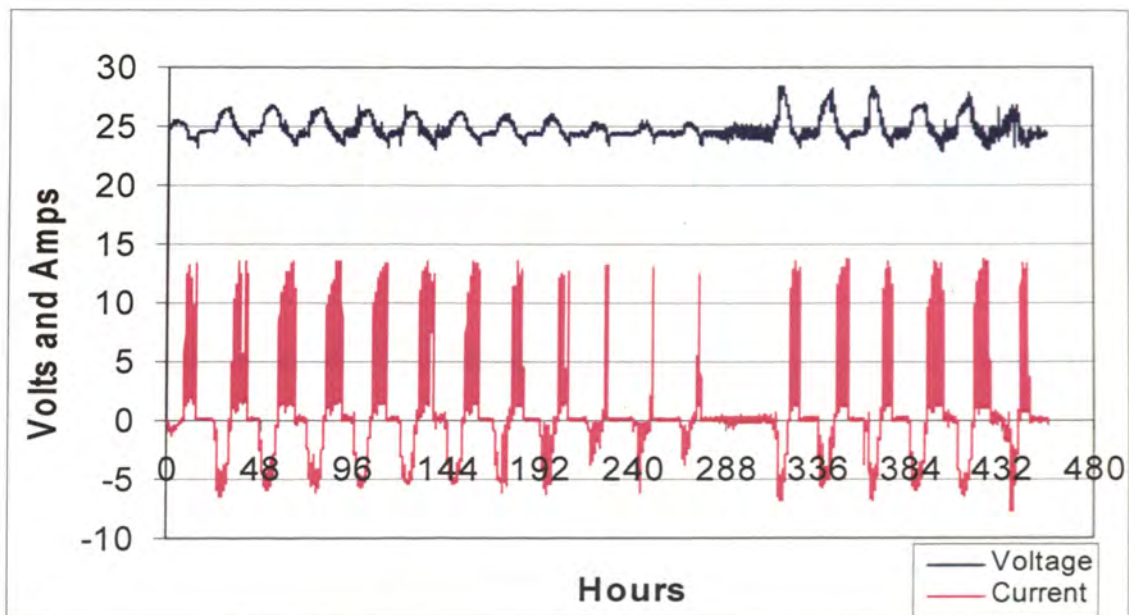

HPS Test One 2006. Results of test show lamp did not make it through the night. The batteries recharge even during overcast skies. Ice storm prevents recharging on November 30. Data collected from November 18 to December 6, 2006.

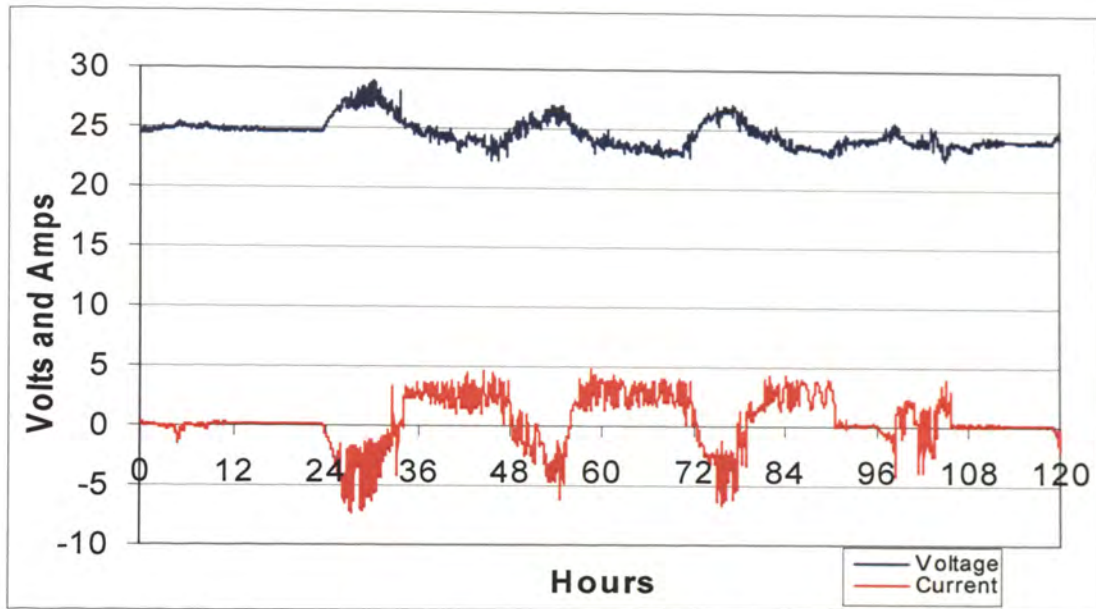

The fluorescent light test on the prototype system had a constant load of 64W on system for four days. Results show the effect the load had on the batteries from February 13 – 17, 2007.

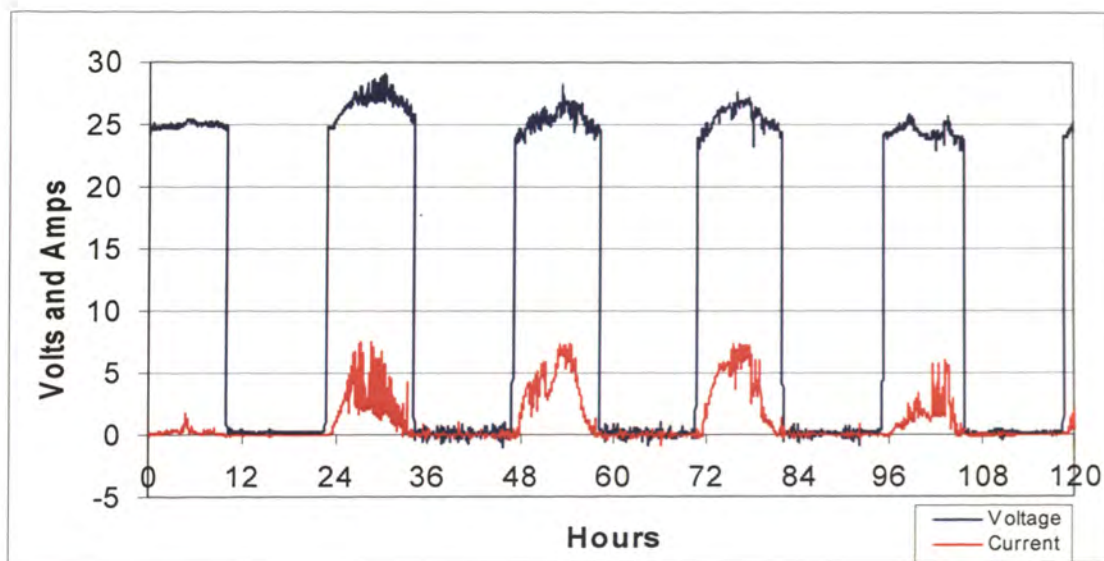

Fluorescent light test results, showing the voltage and current values collected by the panel, from February 13 – 17, 2007.

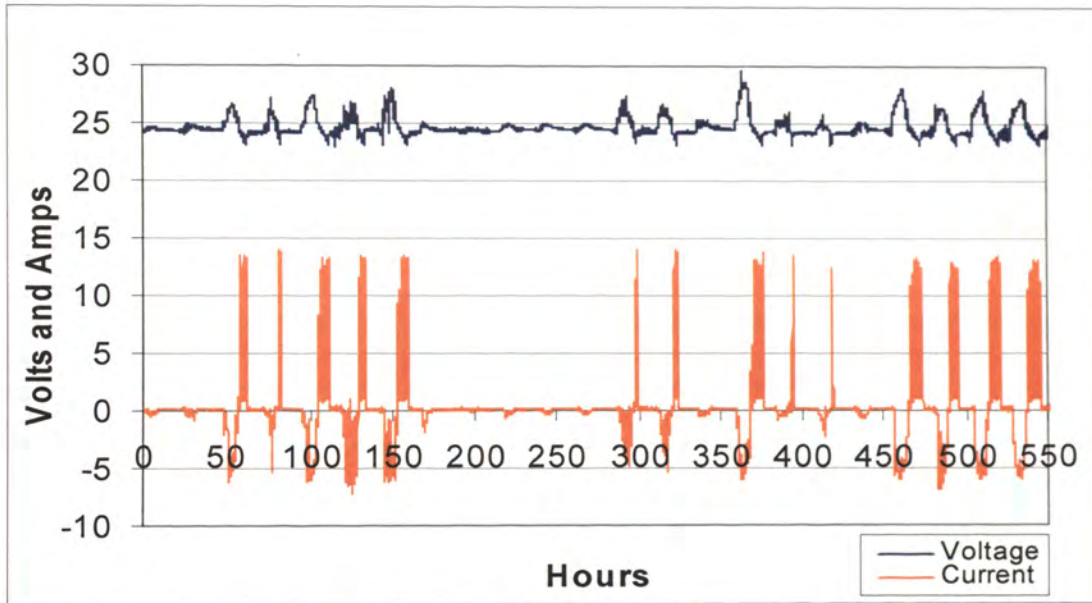

HPS System Test for winter 2007. Ice and snow affected the batteries by covering panel.
The values collected from January 4 – 26.

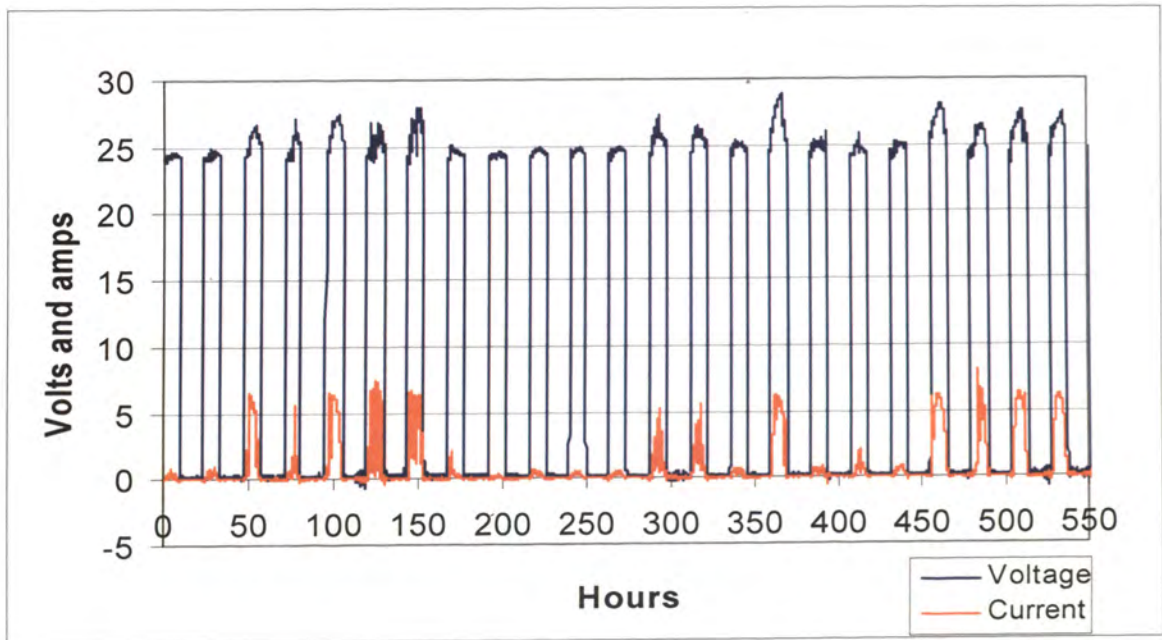

HPS System Test for winter 2007. Ice and snow affected the abilities of the panel to collect energy. The values collected from January 4 – 26.

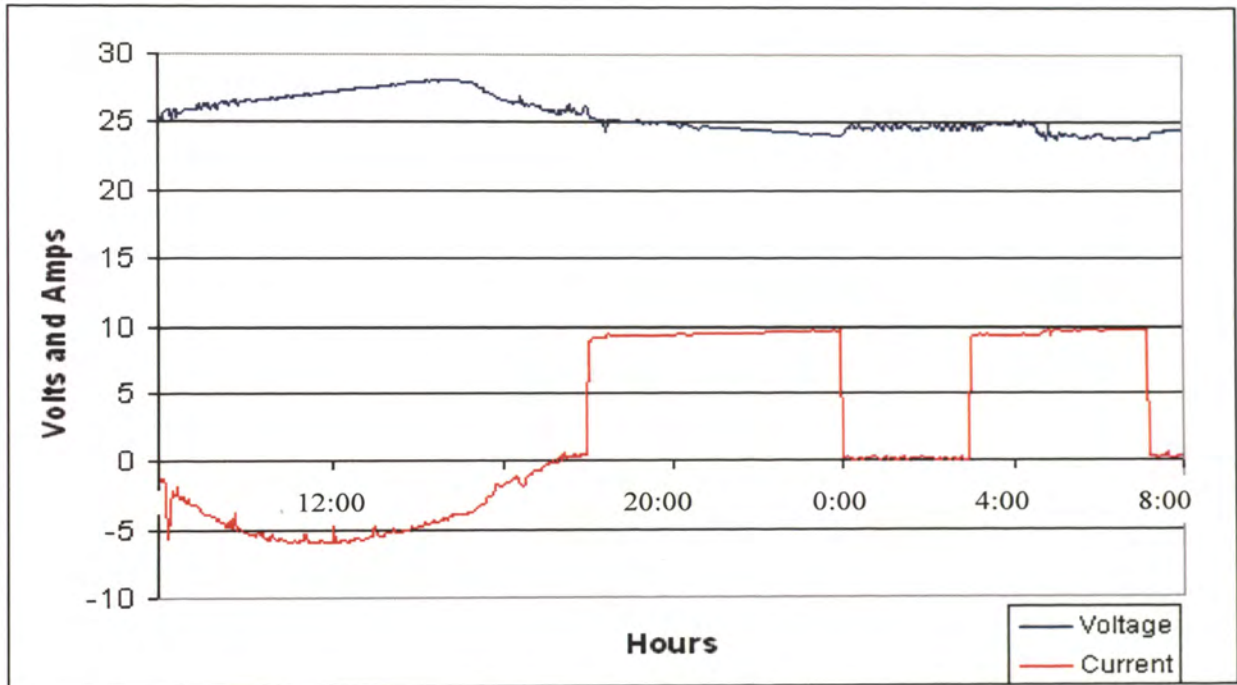

HPS Timer Test. Shutting off lamp for three hours allowed lamp to last till sunrise. Test conducted on February 11, 2007.

APPENDIX B.

HYBRID2 INPUT AND OUTPUT POWER GRAPHS

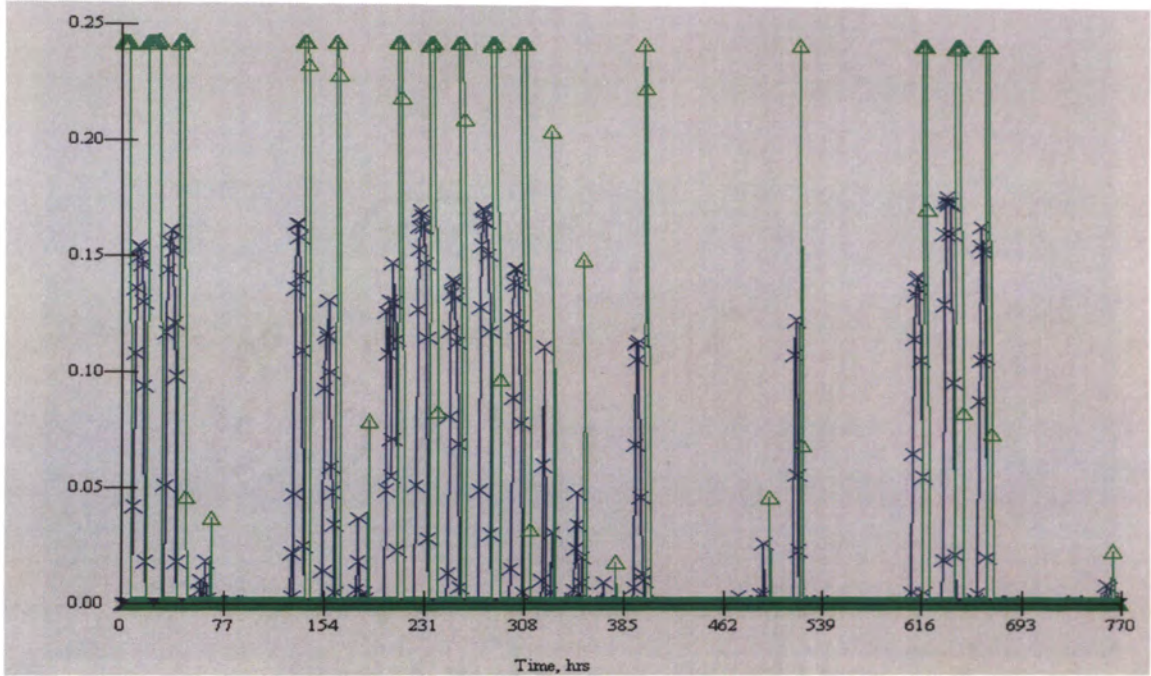

Figure 4: Battery Energy for 100W Prototype System
Green: KW Used by Lamp, Blue: Power Generated by Panel

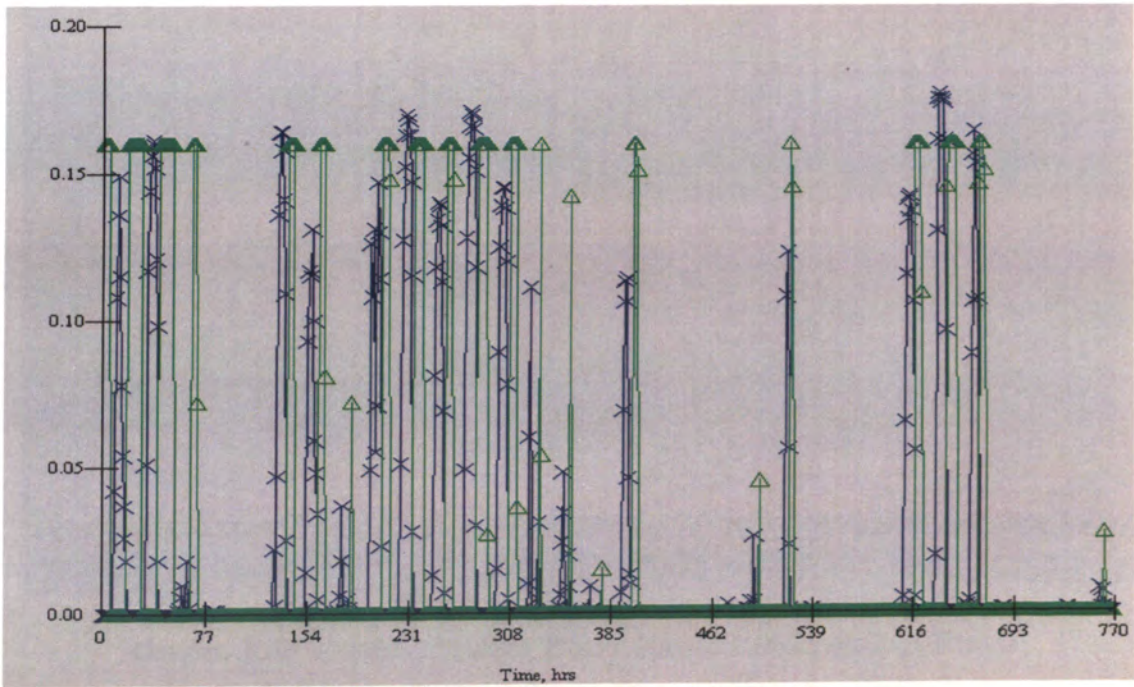

Figure 7: Battery Energy for Ameren Lamp
Green: KW Used by Lamp, Blue: Power Generated by Panel

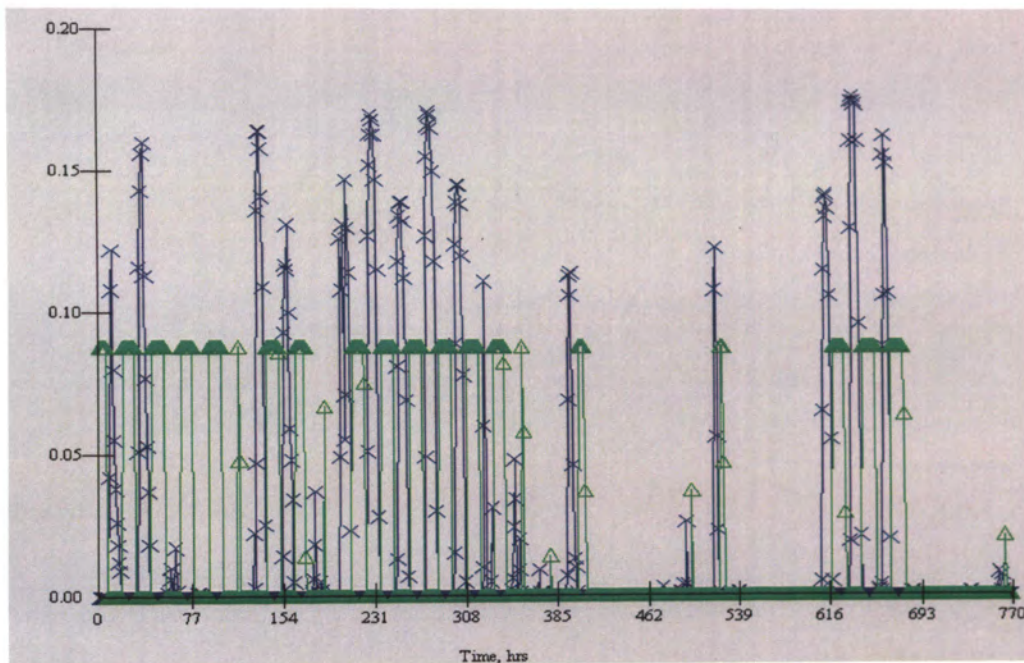

Figure 10: Battery Energy for LPS Lamp
Green: KW Used by Lamp, Blue: Power Generated by Panel

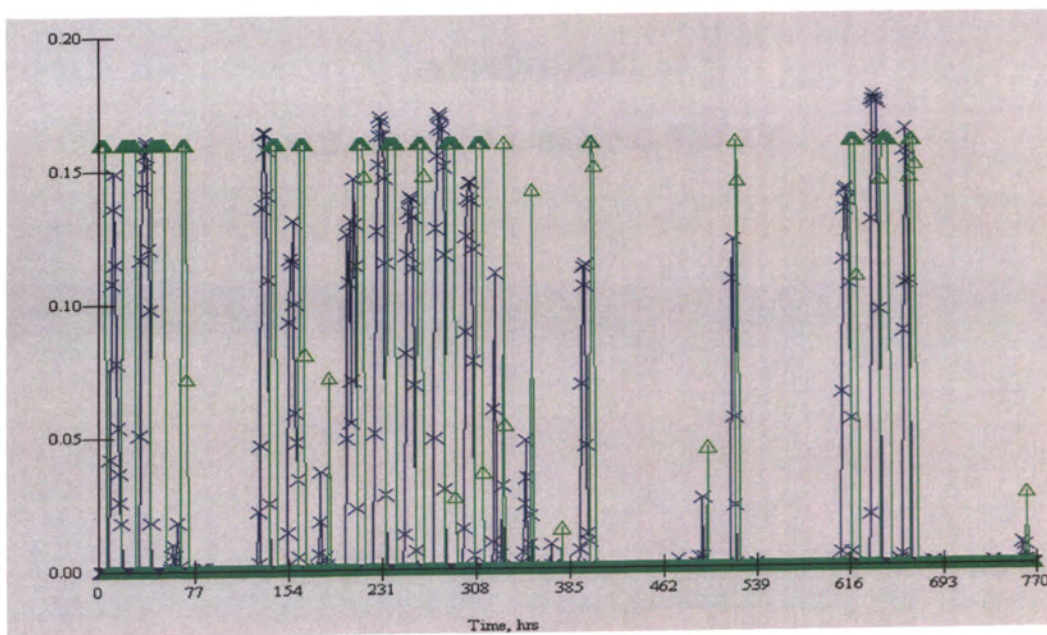

Figure 12: Battery Energy for LED Lamp
Green: KW Used by Lamp, Blue: Power Generated by Panel

APPENDIX C.
SOLAR PANEL SIZING SHEET

SOLAR PANEL SIZE

NORTHWEST POWER CO

www.nwpwr.com

1. Total average amp hours per day from the Systems Loads Sheet line 10	_____	_____
2. Multiply line 1 by 1.2 to compensate for loss from battery charge/discharge	_____ 1.2 _____	_____
3. Average sun hours per day in your area	_____	_____
4. Divide line 2 by line 3. This is the total solar array amps required.	_____	_____
5. Optimum or peak amps of solar module used. See module specifications example is (SP75 is 4.4 amps)	_____	_____
6. Total number of solar modules in parallel required. Divide line 4 by 5	_____	_____
7. Round off to the next highest whole number.	_____	_____
8. Number of modules in each series string to provide DC battery voltage:	_____	_____
9. Total number of modules required: Multiply line 7 by line 8	_____	_____

Figure: Panel Sizing Calculations Sheet
http://www.nwpwr.com/calculation_help/solar_panel_size.htm

APPENDIX D.

LED LAMP OUTPUT LIGHTING



Close-up look at LED light in operation. The focused light provides pin point light directly beneath the lamp.



LED Lamp from 50 feet away. The cool white light of the LED, limited light pollution outside of focal point.

BIBLIOGRAPHY

- [1] S. Harrington, T. Hund, "Photovoltaic Lighting System Performance," Twenty Fifth IEEE Photovoltaic Specialists Conference. Pg. 1307-1310. May 1996.
- [2] S. Hiranvardom, "A Comparative Analysis of Photovoltaic Street Lighting Systems Installed in Thailand," Photovoltaic Energy Conversion, 2003 Proceedings of 3rd World Conference. Volume 3, Pg. 2478-2481. May 2003.
- [3] W. Libo, Z. Zhengming, L. Jianzheng, W. Jian, "Implementation of a Stand-alone Photovoltaic Lighting System with Maximum Power Point Tracking and High Pressure Sodium Lamp," The Fifth Internal Conference, Power Electronics and Drive Systems. Volume 2, Pg. 1570-1573. November 2003.
- [4] S. Ben-Yaakov, M. Gulko, "Design and Performance of an Electronic Ballast for High Pressure Sodium (HPS) Lamps," IEEE Transactions on Industrial Electronics. Volume 44, Issue 4. Pg. 486-491. August 1997.
- [5] V. Salas, M. Manzananas, A. Lazaro, A. Barrado, E. Olias, "The Control Strategies for Photovoltaic Regulators Applied to Stand-alone Systems," Industrial Electronics Society, IEEE. Volume 4, Pg. 3274-3279. November 2002.
- [6] Tetra Tech EM Inc., "Technology Assessment of Light Emitting Diodes (LED) for Street and Parking Lot Lighting Applications," San Diego Regional Energy Office. August 2003. Last Retrieved March 31, 2007. http://www.sdenergy.org/uploads/case_LEDtechAssessment.pdf
- [7] Wikipedia, "Wind Power," Wikimedia Foundation. 2007. Last Retrieved March 30, 2007 from http://en.wikipedia.org/wiki/Wind_power
- [8] CanREN, "About Hydroelectric Energy," Natural Resources Canada. June 2006. Last Retrieved on March 28, 2007. http://www.canren.gc.ca/tech_appl/index.asp?CaId=4&PgId=26
- [9] C. Austin, R. Borja, J. Phillips, "OPERATION SOLAR EAGLE: A Study Examining Photovoltaic (PV) Solar Power as an Alternative for the Rebuilding of the Iraqi Electrical Power Generation Infrastructure," Naval Postgraduate School. June 2005. Last Retrieved March 30, 2007 <http://www.fas.org/man/eprint/iraqsolar.pdf>
- [10] Wind and Hydropower Technologies Program, "Advantages and Disadvantages of Wind Energy," U.S. Department of Energy. August 2005. Last Retrieved March 31, 2007. http://www1.eere.energy.gov/windandhydro/wind_ad.html

- [11] Wind and Hydropower Technologies Program, "Wind Energy Resource Potential." U.S. Department of Energy. September 2005. Last Retrieved March 21, 2007. http://www1.eere.energy.gov/windandhydro_potential.html
- [12] T. Hammons, "Geothermal Power Generation Worldwide," Power Tech Conference Proceedings, IEEE Bologna. Volume 1, Pg. 1-8. June 2003.
- [13] S. Sheth, M. Shahidehpour, "Geothermal Energy in Power Systems." Power Engineering Society General Meeting. volume 2, Pg. 1972-1977. June 2004.
- [14] Citizens and Scientists for Environmental Solutions, "How Hydroelectric Energy Works," Union of Concerned Scientists. September 2005. Last Retrieved March 19, 2007. http://www.ucsusa.org/clean_energy/renewable_energy_basics/how-hydroelectric-energy-works.html
- [15] A. Darvill, "Hydro-electric power is generated from falling water." Energy Resources. December 2006. Last Retrieved March 19, 2007. <http://home.clara.net/darvill/altenerg/hydro.htm>
- [16] T. Penick, B. Louk, "Photovoltaic Power Generation," TEI Controls. December 1998. Last Retrieved March 30, 2007. <http://www.teicontrols.com/notes/TechCommunicationsEE333T/FinalReport-PhotovoltaicPowerGeneration.pdf>
- [17] R. Messenger, J. Ventre, "Photovoltaic Systems Engineering," 1st Ed. New York: CRC Press, 2000, pp.63-64, pp. 53, 64, 297-303.
- [18] Intusoft Newsletter, "Newsletter Issue #78," Intusoft. November 2005. Last Retrieved March 26, 2007. <http://www.intusoft.com/nlhtml/nl78.htm>
- [19] F. Ishengoma, L. Norum, "Design and implementation of a digitally controlled stand-alone photovoltaic power supply," Nordic Workshop on Power and Industrial Electronics. Pg. 1-5. August 2002. Last Retrieved March 30, 2007. <http://www.elkraft.ntnu.no/en/Papers2002/Design-and-impl-norpie02.pdf>
- [20] P. Symanski, "Money from the Sun," Home Power, the Hands on Journal of Home-Made Power. April 2004. Last Retrieved March 30, 2007. <http://www.scottsdaleaz.gov/greenbuilding/Resources/SolarEconomics.pdf>
- [21] National Climate Data Center, "Cloudiness – Mean Number of Days." Retrieved March 30, 2007. <http://www.ncdc.noaa.gov/oa/climate/online/ccd/clpcdy.txt>
- [22] S. Tennakoon, W. Keerthipala, W. Lawrance, "Solar Energy for Development of a Cost-Effective Building Energy System," International Conference on Power System Technology. Volume 1, Pg. 55-59. Dec 2000.

- [23] Y. Lo, J. Lin, T. Wu, "Grid-Connection Technique for a Photovoltaic System with Power Factor Correction," International Conference on Power Electronics and Drives Systems. Volume 1, Pg. 522-525. Jan. 2006.
- [24] D. Mayer, M. Heidenreich, "Performance Analysis of Stand-alone PV Systems from a Rational Use of Energy Point of View," 3rd World Conference of Photovoltaic Energy Conversion. Pg. 2155-2158. May 2003.
- [25] S.M. Alghuwainem. "Steady-state performance of DC motors supplied from photovoltaic generators with step-up converter," IEEE Transactions on Energy Conversion. Volume 7, No. 2. Pg. 267-271. June 1992.
- [26] M. Davis, B. Dougherty, A. Fannee. "Short-term characterization of building integrated photovoltaic panels," Journal of Solar Energy Engineering. volume 125, Issue 1. Pg. 13-20. February 2003.
- [27] Solar Programme, "Basic Photovoltaic Material," The Solar Programme for Photovoltaics in the UK. 2000. Last Retrieved March 30, 2007. <http://www.solar.org.uk/html/school-info/ks4/ks4-1c.html>
- [28] G.R. Walker, P.C. Sernia, "Cascaded DC-DC Converter Connection of Photovoltaic Modules," IEEE Transactions on Power Electronics. Volume 19, No. 4. Pg 1130-1139. July 2004.
- [29] J. Appelbaum, "The operation of loads powered by separate sources or by a common source of solar cells," IEEE Transactions on Energy Conversion. Volume 4, No. 3. Pg. 351-357. September 1989.
- [30] S. Yuvarajan, S. Xu, "Photo-Voltaic Power Converter with a Simple Maximum-Power-Point-Tracker," International Symposium on Circuits and Systems. Volume 3, Pg. 399-402. May 2003.
- [31] K. Hussein, I. Muta, T. Hoshino, M. Osakada. "Maximum photovoltaic power tracking: an algorithm for rapidly changing atmospheric conditions." IEEE Proceedings - Generation, Transmission and Distribution. Volume 142, Issue 1. Pg. 59-64. January 1995.
- [32] P. Barbosa, L. Rolim, E. Watanabe, R. Hanitsch, "Control strategy for grid-connected DC-AC converters with load power factor correction." Generation, Transmission and Distribution. Volume 145, Issue 5. Pg. 487-491. September 1998.
- [33] Rolls Surette, "Deep Cycle Marine HT-8DM" Last Retrieved March 31, 2007. <http://www.rollsbattery.com/>
- [34] Wikipedia, the free encyclopedia, "Street Light," Wikimedia Foundation. Last Retrieved March 31, 2007. http://en.wikipedia.org/wiki/Street_Light.

- [35] P. Harrington, "Design of an Energy Efficient Outdoor Nighttime Urban Lighting System," New York Institute of Technology. 1995. Last Retrieved March 12, 2007. <http://www.philharrington.net/thesis.pdf>
- [36] OkSolar, "Solar outdoor area lighting," 2001. Last Retrieved March 31, 2007. http://www.oksolar.com/0_n_cart/htm/160608.htm
- [37] L. Conley, "M400 Cobrahead-Styled LED Streetlight Will Have You Seeing Stars." LEDtronics. February 2004. Last Retrieved March 23, 2007. http://www.ledtronics.com/product_news/inr_article_021704.htm
- [38] C. Hua, P. Ku, "Implementation of a Stand-Alone Photovoltaic Lighting System with MPPT, Battery Charger and High Brightness LEDs," Power Electronics and Drives Systems. Volume 2, Pg. 1601-1605. November 2005.
- [39] University of Massachusetts, "Hybrid2: Introduction," November 1998. Last Retrieved March 12, 2007. <http://www.ecs.umass.edu/mie/labs/rerl/hys/intro.htm>
- [40] National Solar Radiation Data Base, "30-year (1961-1990) average of solar radiation and illuminance for each month," Last Retrieved March 30, 2007. http://rredc.nrel.gov/solar/old_data/nsrdb/
- [41] D. Larson, "Air Temperature," Tyson Research Center. 2007. Last Retrieved March 31, 2007. <http://www.biology.wustl.edu/tyson/archives.html>

VITA

Joshua David Bollinger was born on April 8, 1981 in Cape Girardeau Missouri. He became interested in becoming an engineer his senior year of high school. The decision to get a degree in electrical engineering came as the result of a lightning strike. The idea of harnessing the energy from nature became a curiosity, which led him down the path towards focus power generation. He earned his Bachelor of Science Degree in Electrical Engineering from the University of Missouri – Columbia in the spring of 2004. He finished his Master of Science Degree in Electrical Engineering from the University of Missouri -- Rolla in the spring of 2007. The focus of his master's was on renewable energy, mainly on the studies of solar energy. His class studies fell into the category of Power Electronics and covered topics ranging from motor design, to power electronics, to power systems quality.

Joshua's accomplishments include the Grainger Award, Knight of St. Patrick, Order of the Engineer, and Recipient of the Dean's List. He was a member of Eta Kappa Nu, Phi Mu Alpha, IEEE, Solar House Team, and Marching Mizzou. On the solar house team, he was in charge of designing the electrical wiring schematics and lighting for the 2007 house. The project gave him an opportunity to work with solar energy on a scale larger than his research project. His goals after graduation are to gain employment with Ameren UE as an associate engineer. His educational goals are to continue to study solar energy and wind energy.