

2013

Study on effects of supply voltage asymmetry and distortion on induction machine

Prashanna Dev Bhattarai

Louisiana State University and Agricultural and Mechanical College, pbhatt3@tigers.lsu.edu

Follow this and additional works at: https://digitalcommons.lsu.edu/gradschool_theses



Part of the [Electrical and Computer Engineering Commons](#)

Recommended Citation

Bhattarai, Prashanna Dev, "Study on effects of supply voltage asymmetry and distortion on induction machine" (2013). *LSU Master's Theses*. 1955.

https://digitalcommons.lsu.edu/gradschool_theses/1955

This Thesis is brought to you for free and open access by the Graduate School at LSU Digital Commons. It has been accepted for inclusion in LSU Master's Theses by an authorized graduate school editor of LSU Digital Commons. For more information, please contact gradetd@lsu.edu.

STUDY ON EFFECTS OF SUPPLY VOLTAGE ASYMMETRY AND DISTORTION ON
INDUCTION MACHINE

A Thesis

Submitted to the Graduate Faculty of the
Louisiana State University and
Agricultural and Mechanical College
in partial fulfillment of the
requirements for the degree of
Master of Science in Electrical Engineering

In

The Department of Electrical and Computer Engineering

by

Prashanna Dev Bhattarai

Bachelor of Electrical Engineering, Tribhuvan University, Nepal, 2008

May 2013

ACKNOWLEDGEMENTS

I would like to thank all my friends and colleagues for supporting me in my academic and social undertakings. I would especially like to thank my colleagues at Louisiana State University for their endless support and guidance during the pursuit of this thesis. I would like to mention Mr Tracy Toups, Mr Paul Haley and Mr. Kashi Ram Kafle. My special thanks go to Jyotsaana, who has been by my side throughout my endeavors.

I would also like to convey my thanks to the Department of Electrical Engineering of Louisiana State University for providing me with an opportunity to pursue my higher studies. I am committed to repaying back with my academic achievements.

I am grateful to Dr. Ernest Mendrela, Dr. Shahab Mehraeen and Mr Mike McAnelly for agreeing to be a part of my committee and for all the help and guidance they have provided.

My utmost respect and appreciation goes to my major professor Dr Leszek Czarnecki, for whom I have high regards, both academic and personal. I feel privileged to work under his guidance and for all the support I have received from him and his wife Mrs Maria Czarnecka.

I thank God for providing me with all the intellect, health and opportunities to this day.

Above all, I would like to express my love and gratefulness towards my parents, Manju and Kalyan, to whom I owe everything. Thank you for providing me with wonderful opportunities, righteous values and everlasting support. I feel honored to have you as my parents. Thanks a lot!

TABLE OF CONTENTS

ACKNOWLEDGEMENTS	ii
LIST OF TABLES	vii
LIST OF FIGURES	ix
ABSTRACT	xi
CHAPTER 1: INTRODUCTION.....	1
1.1 Background on induction machines	1
1.2 Thesis subject	3
1.3 Thesis objective and approach	3
CHAPTER 2: OPERATION OF INDUCTION MACHINE UNDER IDEAL VOLTAGE SUPPLY.....	4
2.1 Introduction	4
2.2 Generation of circular rotating magnetic field in the air gap	4
2.3 Rotor slip	7
2.4 Single phase equivalent circuit of induction machines	8
2.5 Power relations in induction machines	12
2.6 Torque	13
2.7 Efficiency	15
CHAPTER 3: OPERATION OF INDUCTION MACHINES UNDER ASYMMETRICAL SUPPLY VOLTAGE.....	16
3.1 Introduction.....	16
3.2 Causes of voltage asymmetry.....	17
3.2.1 Structural asymmetry.....	18
3.2.2 Voltage asymmetry as a response to current asymmetry	18

3.3 Measures of voltage asymmetry	19
3.4 Limitations of the single phase equivalent circuit of induction machines	20
3.5 Equivalent circuit of the machine under sinusoidal asymmetrical supply voltage	21
3.6 Analysis of machine performance under asymmetrical supply	22
3.6.1 Torque	24
3.6.2 Rotor Currents	27
3.6.3 Losses	29
3.6.4 Efficiency	31
3.6.5 Life expectancy and de-rating of machines	33
CHAPTER 4: OPERATION OF INDUCTION MACHINES UNDER DISTORTED SUPPLY VOLTAGE.....	34
4.1 Introduction	34
4.2 Types and causes of voltage and current distortion	34
4.2.1 Distortions originating at the generation level	35
4.2.2 Interaction of voltage and current distortion	35
4.2.3 Non-linear loads	36
4.3 Mathematical representation of a distorted quantity	36
4.4 Measures of voltage and current distortion	41
4.5 Limitations of the single phase equivalent circuit of induction machines	41
4.6 Equivalent circuit of the machine under sinusoidal asymmetrical supply voltage	42
4.7 Analysis of machine performance under asymmetrical supply	44
4.7.1 Torque	46
4.7.2 Rotor Currents	50
4.7.3 Losses	52

4.7.4 Efficiency	54
4.7.5 Life expectancy and de-rating of machines	55
CHAPTER 5: COMPUTER MODELLING AND RESULTS	56
5.1 Introduction	56
5.2 Modeling of induction machine under sinusoidal symmetrical supply voltage	57
5.3 Modeling of induction machine under asymmetrical sinusoidal supply voltage	58
5.3.1 Output torque	58
5.3.2 Performance of machine when connected to a load of constant torque	60
5.3.2.1 Speed	60
5.3.2.2 Losses	61
5.3.2.3 Efficiency and power relations	64
5.3.2.4 Current response of induction machine	67
5.4 Modeling of induction machine under symmetrical distorted supply voltages	69
5.4.1 Output torque	70
5.4.2 Performance of machine when connected to a load of constant torque	73
5.4.2.1 Speed	73
5.4.2.2 Machine equivalent impedance	73
5.4.2.3 Current response of induction machine	74
5.4.2.4 Losses	76
5.4.2.5 Efficiency and power relations	77
5.5 Modeling of induction machine under asymmetrical sinusoidal supply voltage	81
5.6 Conclusion.....	82
CHAPTER 6: CONCLUSION	83

REFERENCES	84
APPENDIX A: NEMA MG-1 STANDARD FOR MACHINES AND GENERATORS DESIGN PARAMETERS	85
APPENDIX B: MATLAB CODE FOR STUDYING THE RESPONSE OF THE MACHINE UNDER SUPPLY VOLTAGE ASYMMETRY	86
APPENDIX C: MATLAB CODE FOR STUDYING THE RESPONSE OF THE MACHINE UNDER SUPPLY VOLTAGE DISTORTION	89
VITA	94

LIST OF TABLES

Table 5.1 Starting and maximum torque at varying VUF	59
Table 5.2 Operating speed and slips at varying VUF	60
Table 5.3 Losses occurring in the machine at varying VUF	61
Table 5.4 Increment in losses at varying VUF	62
Table 5.5 Losses due to the positive sequence at varying VUF	63
Table 5.6 Efficiency at varying VUF	64
Table 5.7 Machine power relations at varying VUF	65
Table 5.8 Power relations in the air gap at varying VUF	66
Table 5.9 Currents in the stator and rotor of the machine at varying VUF	67
Table 5.10 Machine output torques at varying THD levels	72
Table 5.11 Machine speed and slips at varying THD levels	73
Table 5.12 Machine equivalent impedance for different harmonics	74
Table 5.13 Machine currents at varying THD levels for fifth harmonic	75
Table 5.14 Currents at varying THD levels for seventh harmonic	75
Table 5.15 Losses in the machine at varying THD levels for fifth harmonic	76
Table 5.16 Increment in losses for varying THD levels for fifth harmonic	77
Table 5.17 Losses in the machine at varying THD levels for seventh harmonic VUF	77
Table 5.18 Efficiency of the machine at varying THD levels	78
Table 5.19 Power relations in the machine at varying THD levels for fifth harmonic	78

Table 5.20 Power relation in the machine at varying THD level for seventh harmonic	79
Table 5.21 Power relations in the air gap at varying THD levels for fifth harmonic	79
Table 5.22 Power relations in the air gap at varying THD levels for seventh harmonic	80
Table 5.23 Comparison of effects of voltage asymmetry and distortion	81

LIST OF FIGURES

Figure 2.1: Layout of a 2 pole three phase stator winding	5
Figure 2.2: Stator equivalent circuit of induction machine	9
Figure 2.3: Equivalent circuit of rotor of an induction machine	10
Figure 2.4: Single phase equivalent circuit of three phase induction machine	11
Figure 2.5: T-S curve of induction machine showing the different regions of operation	14
Figure 3.1: Single phase equivalent circuit of induction machine	20
Figure 3.2: Positive sequence equivalent circuit	22
Figure 3.3: Negative sequence equivalent circuit	22
Figure 4.1: Representation of a distorted quantity as the sum of two sinusoidal quantities	36
Figure 4.2: Single phase equivalent circuit of induction machine for sinusoidal symmetrical supply voltages	42
Figure 4.3: Single phase equivalent circuit of induction machine for fundamental component	43
Figure 4.4: Single phase equivalent circuit of induction machine for the fifth harmonic component	43
Figure 4.5: Single phase equivalent circuit of induction machine for the seventh harmonic component	43
Figure 5.1: Torque slip plot of induction machine at symmetrical sinusoidal voltage	57
Figure 5.2: T-S plot of induction machine at varying levels of VUF	58
Figure 5.3: Starting torque at varying VUF	59
Figure 5.4: Plot of the total losses at varying VUF	62
Figure 5.5: Plot of efficiency of machine at varying VUF	64

Figure 5.6: Plot of CUF in stator current at varying VUF	68
Figure 5.7: Plot of the torques produced by the fundamental and seventh harmonic component at varying THD	70
Figure 5.8: T-S plot at varying THD levels for the seventh harmonic	71
Figure 5.9: Starting torques at various THD levels for seventh harmonic	71
Figure 5.10: T-S plot for varying THD for fifth harmonic	72

ABSTRACT

Performance of induction motor supplied with asymmetrical and nonsinusoidal supply voltages is studied in this thesis.

Theory of induction motor is first presented for sinusoidal symmetrical supply voltages. Equations for the torque, losses, currents and efficiency are derived. Appropriate changes are made to apply this theory to induction motors operating at nonsinusoidal and asymmetrical supply voltages. Single phase equivalent circuit of the induction motor is presented for both asymmetrical and nonsinusoidal supply voltages. The equations governing operating characteristics are presented. Machine torque, losses, current and efficiency for asymmetrical and nonsinusoidal supply voltages are compared with the same for sinusoidal symmetrical supply voltages. Computer simulation in MATLAB is used to study the impacts of asymmetrical and nonsinusoidal supply voltages on induction machines. Machine torque, losses, current and efficiency are calculated for various levels of voltage asymmetry and distortion. Results of computer simulation are presented.

CHAPTER 1: INTRODUCTION

1.1 Background on induction machines

With an increase in the level of harmonic distortion in distribution system, also often with the voltage asymmetry, induction motors, the most common motors in customer loads, can be affected. About two thirds of the total energy consumed in the United States flows through AC induction machines. They are common in industry because of their features like simplicity of operation, ruggedness of construction and low manufacturing costs. It is also equally important that they operate efficiently and reliably.

A lot of studies have been done on induction machines in the last century and a thorough understanding of their properties has already been build. However, most of the studies have been done under the assumption that the machine operates under a symmetrical three phase supply voltage with no distortion. They are designed to work efficiently under sinusoidal and symmetrical supply. A substantial deviation from it can be fatal to the machine.

Presently, a lot of development has been done in power electronics and therefore, there is a lot of power electronic equipment commonly present in the power system. This equipment is responsible for causing current and voltage distortion. Loads like computers and fluorescent lamps also contribute to distortion. Arc furnaces, which are huge single phase loads, also cause a lot of voltage distortions.

Voltage asymmetry can originate from structural asymmetry and load unbalance. Structural asymmetry means that the elements in the power system aren't symmetrical.(e.g. three lines of a three phase system, three legs of a transformer etc). Moreover, when the load is unbalanced, it draws unbalanced current causing voltage asymmetry.

The current power system is a huge system that has thousands of generating units and an interconnected network of transmission lines. About two thirds of the total load is induction machine load. Such type of a big power system is stiff and is not heavily affected by distortion and asymmetry. However, when a power system is operating in an islanded mode or operating as an independent microgrid, the short circuit power is lower than that of the common power system and the system impedance is relatively high. Such a system could be more susceptible to voltage asymmetry and distortions. Also, the concentration of renewables with power electronic interphase could be relatively higher in a microgrid. Thus the impact of asymmetry and distortion on induction machines can potentially be higher in an isolated microgrid.

An induction machine is designed to work under sinusoidal symmetrical voltage supply. Such a voltage will create a circular rotating magnetic flux in the air gap when supplied to the stator of the machine. This air gap flux induces voltages in the rotor circuit. If the rotor circuit is closed, current can flow in the rotor circuit and the interaction of magnetic fields created by the stator and the rotor produces a rotating torque. When the supply voltage is asymmetrical, it can be decomposed into positive and negative sequence components. Both of these components will create a circular rotating flux in the air gap but the flux created by the negative sequence component rotates in the opposite direction with respect to the flux created by the positive sequence. It creates a negative torque which tries to rotate the rotor in the opposite direction.

The negative sequence component cannot convey energy to the motor mechanical load. This energy is dissipated as losses. As a result, the machine torque is reduced and losses are increased. Similarly, when the supply voltage is distorted, it has harmonic components in addition to the fundamental. When supplied to the stator of the machine, the fundamental component creates a rotating flux in the gap whose frequency is governed by the supply

frequency. Each harmonic creates a flux in the gap which rotates 'n' times faster than the rotor, where n is the order of harmonic. Depending on the sequence of the harmonic, the rotating flux rotates in the same direction as the rotor or in the opposite direction. The flux of the n order harmonic tries to rotate the rotor many times faster than the fundamental. Since it is not able to do so, most of the energy carried by harmonics goes to losses. From the point of view of the flux produced by harmonics and the negative sequence voltage the machine is in a locked rotor state. Neither the flux created by the negative sequence, nor the harmonics, contributes to electromechanical energy conversion. Rather; it only contributes to losses.

1.2 Thesis subject

The subject of this thesis is induction machine operating under asymmetrical and distorted supply voltage. This includes the impact of supply voltage asymmetry and load imbalance on the machine torque, current response and efficiency.

1.3 Thesis objective and approach

The objective of this thesis is to find out the impact of supply voltage asymmetry and distortion on the operation of induction machines. It includes finding out the mathematical relations that can predict the degree of these impacts. Because of the supply voltage asymmetry and distortion are expected to have different types of impacts on the machine, their impacts will be studied individually. Mathematical equations that relate both supply voltage asymmetry and distortion to the induction machine performance will be developed and their impacts will be studied using simulation in MATLAB. Results from prior studies will be used as references.

CHAPTER 2: OPERATION OF INDUCTION MACHINE UNDER IDEAL VOLTAGE SUPPLY

2.1 Introduction

This chapter presents the basics of induction machine operation. It does not introduce any new ideas; rather it explains the theory that is fundamental for operation of induction machines as well as this chapter introduces symbols and conventions used in this thesis for induction machines description. It would build a bridge into the forthcoming chapters. Induction machines theory presented in this chapter is mainly based on Refs. [2], [3] and [4].

When the stator winding of induction machine is supplied with three phase symmetrical voltage, a circular rotating magnetic field is created in the air gap. This flux induces voltage in the rotor windings. If the rotor winding is kept stationary, induction machine acts like a three phase transformer, where the stator winding is the primary and the rotor winding is a secondary winding. If the rotor circuit is closed by impedance or short circuited, current flows in the rotor winding. The rotor currents also produce a magnetic field. The interaction of the two fields creates a mechanical torque which acts towards aligning magnetic field of the rotor currents with the field of the stator currents. Since, the stator field is rotating, the rotor follows it and hence a rotatory motion of the rotor is achieved.

2.2 Generation of circular rotating magnetic field in the air gap

The stator of an induction machine has distributed windings. If the stator windings are supplied with a voltage, it produces a magnetic field in the air gap which is distributed over the space. If a single winding is supplied with time varying sinusoidal voltage source, the flux can be approximated by the formula:

$$\phi(\theta, t) = \phi_m \sin \theta \cos \omega_s t, \quad (2.1)$$

where,

ϕ_m is the maximum value of the flux

θ is angle associated with the space distribution of windings, explained in Fig. 2.1.

ω_s is the angular frequency of the supply voltage.

Eqn. (2.1) can be rearranged to the form

$$\phi(\theta, t) = \frac{1}{2} \phi_m \{ \sin(\theta - \omega_s t) + \sin(\theta + \omega_s t) \}. \quad (2.2)$$

Eqn. (2.2) describes the air gap flux of a single winding.

The stator of a three phase machine consists of three symmetrical windings displaced from each other in space by 120 degrees. A simplified two pole three phase stator winding is shown in Figure 2.1.

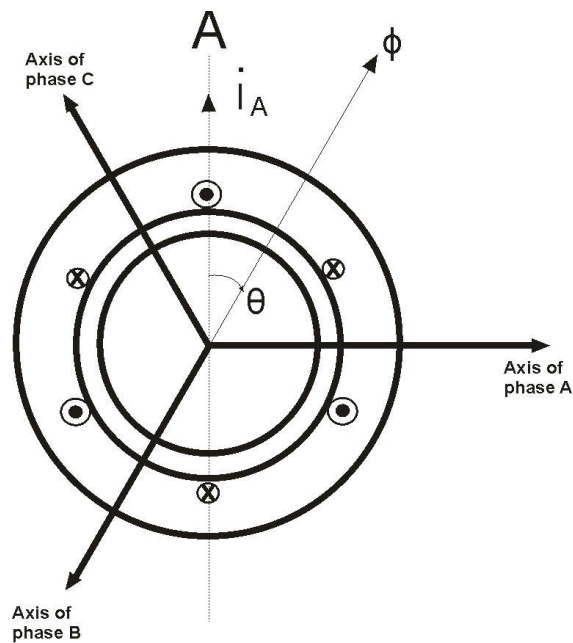

Figure 2.1: Layout of a 2 pole three phase stator winding

When a three phase stator winding, as shown in Fig. 2.1, is supplied with a symmetrical three phase voltage, all the three windings produce air gap fluxes. The flux due to phase A is

$$\phi_A(\theta, t) = \phi_m \{ \sin(\theta) \cos(\omega_s t) \}, \quad (2.3)$$

due to phase B is

$$\phi_B(\theta, t) = \phi_m \left\{ \sin\left(\theta - \frac{2\pi}{3}\right) \cos\left(\omega_s t - \frac{2\pi}{3}\right) \right\}, \quad (2.4)$$

and due to phase C is

$$\phi_C(\theta, t) = \phi_m \sin\left(\theta - \frac{4\pi}{3}\right) \cos\left(\omega_s t - \frac{4\pi}{3}\right) \quad (2.5)$$

Equations (2.3) – (2.5) can be rearranged to the form:

$$\phi_A(\theta, t) = \frac{1}{2} \phi_m \{ \sin(\theta - \omega_s t) + \sin(\theta + \omega_s t) \}, \quad (2.6)$$

$$\phi_B(\theta, t) = \frac{1}{2} \phi_m \left\{ \sin(\theta - \omega_s t) + \sin\left(\theta + \omega_s t - \frac{4\pi}{3}\right) \right\}, \quad (2.7)$$

and

$$\phi_C(\theta, t) = \frac{1}{2} \phi_m \left\{ \sin(\theta - \omega_s t) + \sin\left(\theta + \omega_s t - \frac{2\pi}{3}\right) \right\}. \quad (2.8)$$

The total air gap flux in the air gap ($\phi(\theta, t)$) is the sum of the fluxes created by individual windings, i.e., the sum of fluxes in specified by eqns. (2.6), (2.7) and (2.8) This sum is equal to

$$\phi(\theta, t) = \frac{3}{2} \phi_m \sin(\theta - \omega_s t). \quad (2.9)$$

Eqn. (2.9) gives the expression for the total air gap flux when the stator windings are supplied with symmetrical sinusoidal voltages. Thus, the flux in the air gap of the machine is therefore a circular rotating flux.

The angular rotating speed of the rotating field is

$$n = \frac{120 f}{p}, \quad (2.10)$$

where

f is the frequency of supply voltage

p is the number of pole pairs

The RMS value of the voltage induced in the rotor winding is equal to

$$E = \sqrt{2} \pi f k N \Phi_p, \quad (2.11)$$

where,

k is winding factor

N is number of turns in series per phase

Φ_p is air gap magnetic flux per pole

2.3 Rotor slip

At a motor start, the rotor is at standstill. As explained earlier, when the magnetic flux in the rotor windings change with time, a voltage is generated in the rotor. This voltage is generated as a result of induction and hence the name induction motors. At standstill the frequency of the voltage in the rotor is equal to the frequency of the supply voltage f or angular frequency ω_s . Just like the stator, a wound rotor also has three phase symmetrical windings. Likewise, the rotor windings are excited by induced by symmetrical three phase voltages that are shifted mutually in time by one third of the period T . Therefore, in accordance to the principles discussed earlier in this chapter, the rotor currents also create a circular rotating magnetic flux in the gap. At standstill, the angular frequency of the air gap flux created by the rotor is also ω_s . Since there are two fields in the air gap, they interact with each other and this interaction results in creating a

torque. And as explained earlier, since the rotor is movable, this torque rotates the rotor. It should be noted that for the rotation to occur, the electric torque produced by the machine has to overcome the mechanical torque of the load.

Let us assume that the rotor is rotating at an angular frequency of ω_r in the same direction as the rotating field in the gap produced by the stator. If the angular frequency of the field produced by the stator winding is ω_s , then relative speed of the stator and rotor fields is described as a slip and defined as

$$s = \frac{\omega_s - \omega_r}{\omega_s}. \quad (2.12)$$

The relative movement of the rotor windings and the field created by stator windings creates a voltage in the rotor windings whose angular frequency is $s\omega_s$. This produces a rotating flux in the gap which is rotating at $s\omega_s$ with respect to the rotor. However, the rotor is already mechanically rotating at ω_r from the point of view of the stator in the same direction. Thus the angular frequency of the flux produced by rotor windings, with respect to the stator is

$$s\omega_s + \omega_r = \omega_s \quad (2.13)$$

This means that the flux produced by the rotor windings rotates at the same speed as that produced by the stator.

2.4 Single phase equivalent circuit of induction machines

It is assumed that the machine has structural symmetry and is supplied with sinusoidal symmetrical voltages. Under this condition we derive the relations for one phase of the machine.

A three phase induction machine can be analyzed using an equivalent circuit of a single phase.

The rotating air gap flux not only induces voltages in the rotor circuits, but also induces balanced counter voltage in the stator circuit.

The voltage relation can be shown as

$$V_s = E_s + (R_s + j X_s) I_s \quad (2.14)$$

where,

V_s is stator voltage (line to neutral) complex RMS (CRMS) value

E_s is stator counter voltage (line to neutral) CRMS value

I_s is stator current CRMS value

R_s is stator effective resistance

X_s is stator leakage resistance.

The total air gap flux is due to the summation of the flux created by the currents in the rotor windings and the stator windings. The stator current can be separated into exciting component and load component. The former is responsible for creating air gap flux while the latter is responsible for producing torque. The equivalent circuit that represents the stator is similar to that representing the primary of the transformer.

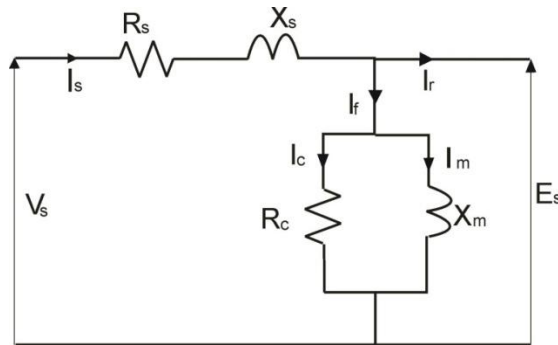

Figure 2.2: Stator equivalent circuit of induction machine

To complete the model of the machine, the rotor circuit is considered next. The rotor circuit is represented by equivalent impedance Z_r which is determined by representing the stator and rotor voltages and currents in terms of rotor quantities referred to the stator, such that

$$Z_r = \frac{E_s}{I_r}. \quad (2.15)$$

In case of a transformer, the secondary of the transformer can be replaced by an equivalent secondary winding with the same number of turns as the primary. This can be done by referring the secondary parameters to the primary by considering the number of turns in each. Likewise in the case of an induction machine, we can replace the rotor with an equivalent rotor with the same number of phases and turns as the stator while it produces the same mmf as the actual rotor. Since the rotor of an induction machine is short circuited in normal operation, the impedance seen from voltage perspective is the short circuit impedance of rotor. Thus the relation between the leakage reactance at slip frequency of the equivalent rotor to that of the actual rotor will be

$$Z_{rs} = N_e^2 Z_r \quad (2.16)$$

Where N_e is the effective turns ratio between the stator winding and actual rotor winding. When the number of turns is taken into account, we can replace Z_{rs} by Z'_{rs} . Next, we have to consider the relative movement between the stator and the rotor. Our goal is to find an equivalent circuit of the rotor that is stationary but incorporates the relative movement at slip frequency.

For the rotor circuit,

$$Z'_{rs} = \frac{E_{ss}}{I_{rs}} \quad (2.17)$$

Where E_{ss} and I_{rs} refer to the induced stator voltage and rotor current at slip frequency. The equivalent circuit of the rotor can be shown as 2.3.

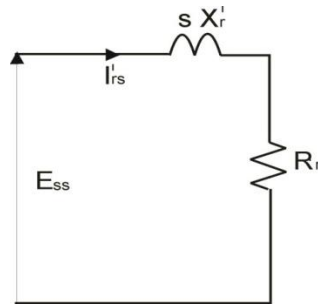

Figure 2.3: Equivalent circuit of rotor of an induction machine

Because the equivalent rotor current has been defined in a way to have same flux effects as the rotor current, we can write

$$I_{rs} = I'_r \quad (2.18)$$

Also, the resultant flux induces both the voltage E_{ss} and E_s . These two are different in magnitude because of the rotation of the machine. These can be related as

$$E_{ss} = s E_s \quad (2.19)$$

Replacing (2.18) and (2.19) in (2.17) we get,

$$Z'_{rs} = \frac{s E_s}{I'_r} = R'_r + j s X'_r \quad (2.20)$$

Dividing by slip 's' we get

$$Z'_r = \frac{R'_r}{s} + j X'_r \quad (2.21)$$

Z'_r gives the impedance of the equivalent rotor in the stator equivalent circuit. In the final equivalent circuit of the machine, all the parameters are referred to the stator and their frequencies are at stator frequency.

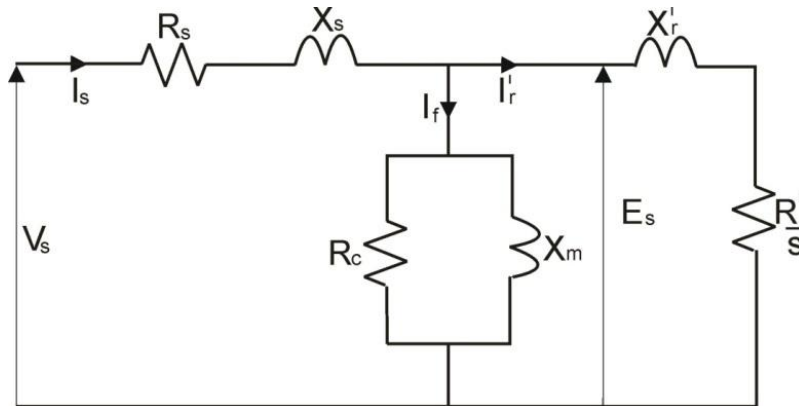

Figure 2.4: Single phase equivalent circuit of three phase induction machine

2.5 Power relations in induction machines

Referring to the per phase equivalent circuit of induction machine shown in 2.4, the total power that is transferred from the stator across the air gap and to the rotor, known as air gap power is given by:

$$P_g = 3 (I_r')^2 \frac{R_r'}{s} \quad (2.22)$$

Where the number of phases is three and the RMS value of current is considered.

The total power loss in the rotor (rotor power) can be calculated from the equivalent circuit as

$$P_r = 3 (I_r')^2 R_r' \quad (2.23)$$

The electromagnetic power developed by the machine is the net power of the machine which is calculated by subtracting the rotor power loss from the air gap power, such that

$$P_m = P_g - P_r \quad (2.24)$$

We finally get

$$P_m = 3 (I_r')^2 R_r' \frac{1-s}{s} \quad (2.25)$$

Comparing the air gap power, rotor loss (rotor power) and electromagnetic power, we obtain

$$P_m = (1-s)P_g \quad (2.26)$$

And,

$$P_r = s P_g \quad (2.27)$$

This implies that out of the total power crossing the air gap, $(1-s)$ portion is converted into mechanical power, while the portion s is dissipated as heat. This also implies that the higher the operating speed, the lower the slip, and more efficient the machine.

One important thing to note is that when considering the power relations in the induction machine, the losses in the stator have been ignored. This simplifies the analysis of the machine and makes it easier to handle the equations. On the other hand, for the purposes of simulation, accurate results are desired. Moreover, calculations are performed by computers during simulation and they are well capable of handling complex equations. Thus, the complete model of the machine is used for simulation purposes. The results of simulation are presented in the fifth chapter of this thesis.

2.6 Torque

The mechanical power is the product of the electromechanical torque and the angular mechanical speed or rotor speed. Thus,

$$T_e = \frac{P_m}{\omega_r} = \frac{P_g}{\omega_s}. \quad (2.28)$$

Substituting the expression of P_g we get,

$$T_e = \frac{3 (I_r')^2 R_r'}{s \omega_s}. \quad (2.29)$$

Referring to the equivalent circuit of the machine shown in 2.4,

$$I_r'^2 = \frac{E_s^2}{\left(\frac{R_r'}{s}\right)^2 + (X_r')^2} \quad (2.30)$$

with $E_s \cong V_s$

The expression for electromechanical torque is:

$$T_e = \frac{3 V_s^2 \frac{R_r'}{s}}{\omega_s \left\{ \left(\frac{R_r'}{s}\right)^2 + (X_r')^2 \right\}}. \quad (2.31)$$

If we plot the electromechanical torque against the slip, the resulting diagram is called a torque-slip or torque-slip characteristics curve.

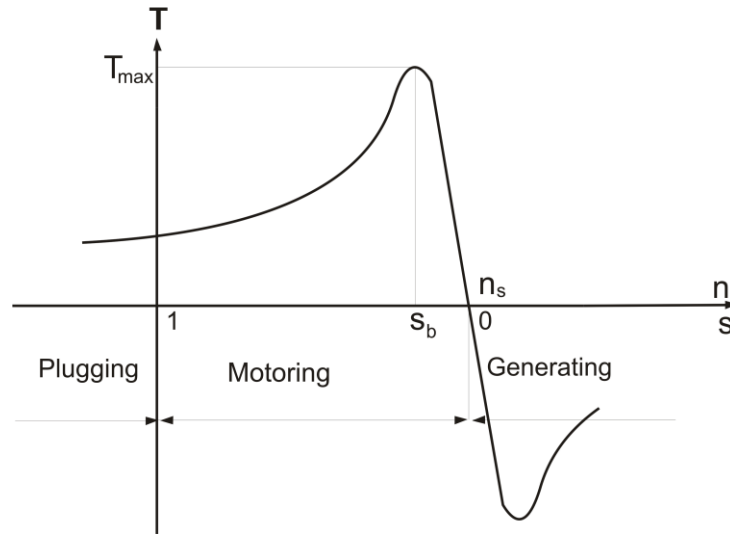

Figure 2.5: Torque - slip curve of induction machine showing the different regions of operation

The maximum electromechanical torque that can be produced by the machine, also known as the breakdown torque can be calculated by differentiating equation (2.31) w.r.t. slip and equating it to zero, viz.

$$\frac{dT_e}{ds} = 0 \quad (2.32)$$

i.e.

$$\frac{d}{ds} \left(\frac{3 V_s^2 \frac{R'_r}{s}}{\omega_s \left\{ \left(\frac{R'_r}{s} \right)^2 + (X'_r)^2 \right\}} \right) = 0 \quad (2.33)$$

Solving the equation we get,

$$s_b \approx \mp \frac{R'_r}{X'_r} \quad (2.34)$$

Using (2.31) and (2.34), the maximum electromechanical torque produced by the machine can be found to be

$$T_{\max} = \frac{3 V_s^2}{2 \omega_s X_r'} \quad (2.35)$$

2.7 Efficiency

Out of the total electrical energy input to the machine, some of it is lost in the rotor and the stator circuits. The efficiency of the induction machine is given by:

$$\eta = \frac{P_{out}}{P_{in}} \quad (2.36)$$

If we assume an ideal case and neglect all other losses except those occurring in the rotor circuit, the total input power is equal to P_g and the total power loss is the rotor power. This means

$$\Delta P = P_r = s P_g \quad (2.37)$$

Therefore,

$$\eta = \frac{P_{out}}{P_{in}} = \frac{P_g - s P_g}{P_g} = (1 - s) \quad (2.38)$$

This means that the closer the induction machine operates to its synchronous speed, the higher is the efficiency. In other words, the operating slip should be as low as possible for better performance.

CHAPTER 3: OPERATION OF INDUCTION MACHINES UNDER ASYMMETRICAL SUPPLY VOLTAGE

3.1 Introduction

The theory of induction machine in the previous chapter was presented under the assumption that the machine was supplied from a three phase source of sinusoidal and symmetrical voltage. Most of the equipment in the power system is designed to work under such voltage. The whole power system is structured to operate under such condition. However, barring the ideal scenario, voltages and currents in the power system are rarely sinusoidal and symmetrical and assuming otherwise can lead to significant errors.

Induction machines are a key part of the power system and like all other equipment they are designed to work under sinusoidal and symmetrical supply voltages. The objective of this thesis is to study the operation of induction machines when subjected to asymmetrical and distorted supply voltage. In this chapter, the focus is given on the effects of asymmetrical supply voltage on induction machines. The next chapter will deal with the effects of supply voltage distortion on induction machines.

One can observe that the terms “asymmetry” and “unbalance” are sometimes used in an ambiguous way. The word unbalance refers to a three phase load that has different phase impedance. On the other hand, asymmetry refers to the condition where the supply voltage or line currents are not symmetrical. By definition, three phase quantities are symmetrical if they are mutually identical but shifted by one third of the period. If $x_R(t)$, $x_S(t)$ and $x_T(t)$ are three quantities, then for them to be symmetrical they should satisfy the relations:

$$x_S(t) \cong x_R\left(t - \frac{T}{3}\right), \quad (3.1)$$

and,

$$x_T(t) \cong x_R\left(t + \frac{T}{3}\right), \quad (3.2)$$

where T is the time period.

If conditions given above are not satisfied then the three phase quantities are said to be asymmetrical.

If the three phase quantities discussed in Eqns. (3.1) to (3.2) are voltages, the definitions also hold for voltage asymmetry. Voltage asymmetry in a power system is accompanied by current asymmetry because the presence of one causes the other and vice versa. We are studying the effects of voltage asymmetry on induction machines and voltage asymmetry leads to current asymmetry. Thus, current asymmetry caused by supply voltage asymmetry is an important part of the study.

3.2 Causes of voltage asymmetry

Although voltage and current asymmetry are interrelated, their causes can be traced to different sources. Primarily there are two causes of voltage asymmetry. The first is due to the asymmetry present in the components of power systems and is referred to as structural asymmetry while the second is due to the asymmetric voltage drop in the system impedance due to the asymmetric current. Current asymmetry is primarily caused because of asymmetrical voltages. But load unbalance and asymmetric faults also contribute to current asymmetry. Both current and voltage asymmetry is discussed briefly in the following sections. Ref [6] presents details of current and voltage asymmetry.

3.2.1 Structural asymmetry

Primary cause of voltage asymmetry is due to the physical asymmetries present in the components of the power system. This type of asymmetry is also termed as structural asymmetry. Some of the main contributors of structural asymmetry are generators, transmission lines and transformers.

Asymmetry may arise in generators if the stator impedances for different phases are not mutually equal. But asymmetry due to generators is normally negligible. Transformers contribute to asymmetry in two ways. The first is through its geometry and it mainly occurs due to the difference in the mutual impedance of the three phases. The second is asymmetry arising due to the configuration of transformers. This can be because of the use of three non-identical transformers as three phase transformers or due to the connection of three single phase transformers in asymmetrical configurations like Open Wye – Open Delta or Open Delta – Open Delta that puts unequal loads on the different transformers. Transmission lines contribute to asymmetry because the geometry of individual conductors with respect to ground and each other can never be identical. Various factors like unequal distance of the three lines from ground or poles, unequal coupling on the central and peripheral lines etc. all contribute to asymmetry. Transposing the lines can mitigate the problem in single circuits but the problem is more complex in case of multi circuit lines.

3.2.2 Voltage asymmetry as a response to current asymmetry

In some cases, the supply voltages may be symmetrical but the currents asymmetric. This happens when the load is unbalanced and draws asymmetric currents. When asymmetric current flows in the system it causes asymmetric drops in the system impedance and causes the voltage to become asymmetric.

One of major cause of current asymmetry in the power system is unbalanced loading on the three phases. When symmetrical voltage is applied to unbalanced three phase loads, the current response will be asymmetrical. Likewise, asymmetrical faults in the power systems also lead to current asymmetry. Sometimes the loads may be balanced but they can be subjected to asymmetrical voltages. Balanced loads will also lead to asymmetrical currents in such cases. Furthermore, some of the components in the power system offer unequal impedance to positive and negative sequences. This means that when subjected to a certain amount of voltages asymmetry, there is increased level of current asymmetry in response. This is strongly evident when asymmetrical voltages are supplied to induction machines.

3.3 Measures of voltage asymmetry

Any three phase periodic quantity can be asymmetrical. The three phase voltages and currents in a power system are sinusoidal quantities. Therefore the word asymmetry in the power system is pertinent to sinusoidal functions. From that standpoint, asymmetry can occur either due to the difference in RMS of the three quantities or due to unequal phase separation. The former is known as magnitude asymmetry and the latter is known as phase asymmetry.

The study on asymmetry was started around the late 1910's or early 1920's. The measurement techniques of asymmetry were limited by measurement capabilities at that time. The technology that was available only enabled measurement of the RMS value and not the phase angles. Likewise, measures of asymmetry varied based on the requirements. For these reasons, the early measures of asymmetry as provided by NEMA and IEEE are only based on RMS values. The advent of digital technology enabled measurements of even the most complex quantities like phase sequence or harmonics. Our focus in on induction machines and we are concerned with the negative and positive sequence components of voltages and currents. The

VUF is adapted as a measure of asymmetry in this thesis. VUF (Voltage Unbalance Factor) is defined as:

$$VUF (\%) = \frac{\text{negative sequence voltage component}}{\text{positive sequence voltage component}} * 100 \%, \quad (3.3)$$

Since we are assuming that the supply is a sinusoidal voltage without any distortion, the VUF definition is adequate in measuring asymmetry.

3.4 Limitations of the single phase equivalent circuit of induction machines

The single phase equivalent circuit of induction machine used in the previous chapter was built using four main assumptions. The first was that the machine has structural symmetry such that symmetrical voltage leads to symmetrical current. The second assumption was that the superposition principle can be applied to it (because the machine can be considered as a linear device). Thus a single phase equivalent circuit was capable of representing the machine completely. The third and the fourth assumptions were regarding the supply voltage. It was assumed that the supply voltage was sinusoidal and symmetrical. Therefore, when the supply voltage is asymmetrical the assumptions made in the previous chapter become invalid, thereby making the model inadequate. Referring to section 2.4 and 2.4 the single phase equivalent circuit of induction machine looked like 3.1.

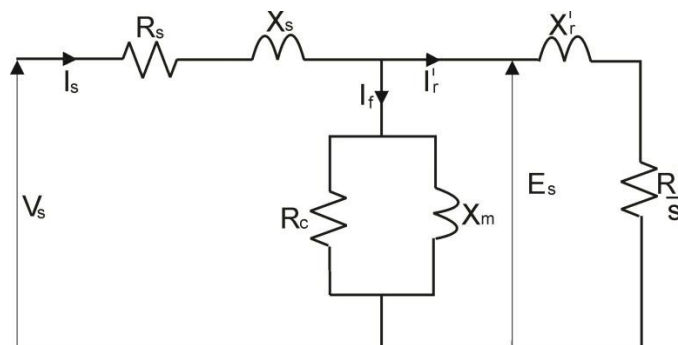

Figure 3.1: Single phase equivalent circuit of induction machine

When the voltage source is symmetrical, then it is entirely composed of positive sequence component. There is only one slip in the machine and Figure 3.1 is adequate. However, when the supply voltage is asymmetrical, it has both the positive and negative sequence components. It is to be noted that we are considering a three wire machine and the zero sequence component do not exist. The positive sequence components produce rotating field and torque in the same direction as the original voltage source. The negative sequence components produce rotating field and torque in the opposite direction. The motor rotates at a different slip with respect to the negative sequence voltage. Thus, Figure 3.1 is not capable of representing the machine. Another model is required that also takes the negative sequence components into account. This problem is tackled by separating the asymmetrical voltage into symmetrical components.

3.5 Equivalent circuit of the machine under sinusoidal asymmetrical supply voltage

The concept of symmetrical components introduced by Charles Fortescue in 1918 states that a system of 'n' asymmetric vectors can be expressed as the sum of 'n' symmetrical sets of vectors. In case of a three phase system, it implies that a set of three asymmetric voltages can be represented by three sets of balanced voltages. The first set is known as the positive sequence and has the same phase sequence as the original three phase voltages. The second set is known as negative sequence and it has phase sequence that is opposite to the original three phase voltages. The third set is known as zero sequence and the three voltages comprising the zero sequence components are in phase with each other. We are analyzing a three wire machine and zero sequence components do not exist in this case.

The supply voltages are decomposed into positive and negative sequence components and single phase equivalent circuit is built for both of them. The machine eventually rotates at a unique angular speed and that speed is what binds the positive and negative sequence circuits

together. There is a unique speed and a unique equivalent torque even when the supply voltages are decomposed into symmetrical components. This is because a machine cannot rotate at two speeds at the same time. For the same reason, the two circuits are interrelated and the response of the positive and negative sequence circuits can be added to find the overall response of the machine.

Figure 3.2 represents the positive sequence equivalent circuit of the machine while Figure 3.3 represents the negative sequence equivalent circuit. The only difference in the two circuits is in the equivalent rotor resistance. The rest of the circuit is the same. Note that the positive sequence voltage on the stator side V_s^p is shown for phase A. Since the positive and negative sequence components are both symmetrical, the principle of superposition can be applied to them individually. Thus, the complete response of the machine for positive and negative sequence can be obtained by studying one phase just like a machine with symmetrical supply

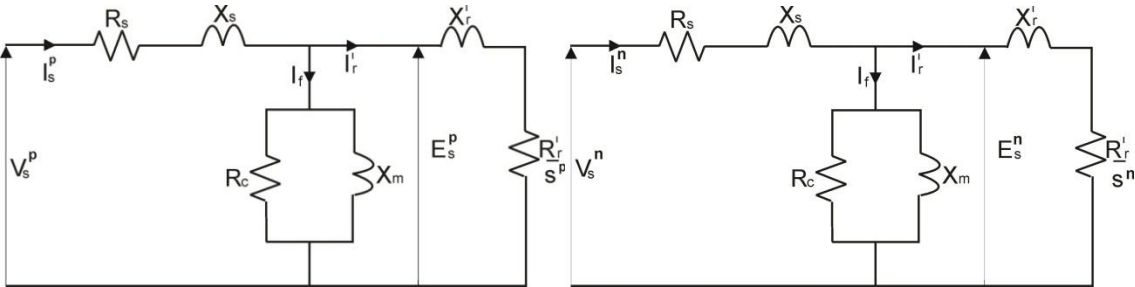

Figure 3.2: Positive sequence equivalent circuit

Figure 3.3: Negative sequence equivalent circuit

3.6 Analysis of machine performance under asymmetrical supply

When induction machine is subjected to asymmetrical voltages, it draws asymmetrical currents with positive and negative sequence components. Both produce rotating magnetic fields of their own. Positive sequence currents produce a field that is in the same direction as the main supply

currents while the negative sequence currents produce field in the opposite direction. This results in an elliptical rotating magnetic field and overall reduction in torque.

Let us recall the slip,

$$s = \frac{\omega_s - \omega_r}{\omega_s} . \quad (3.4)$$

For positive sequence voltage, the positive sequence slip is,

$$s^p = \frac{\omega_s - \omega_r}{\omega_s} = 1 - \frac{\omega_r}{\omega_s} . \quad (3.5)$$

With respect to the negative sequence voltage, the synchronous frequency at which the negative sequence flux rotates is $-\omega_s$. This flux tries to rotate the machine at synchronous speed in the opposite direction or at $-\omega_s$. Thus the negative sequence slip is given by,

$$s^n = \frac{-\omega_s - \omega_r}{-\omega_s} = 1 + \frac{\omega_r}{\omega_s} . \quad (3.6)$$

Let us now introduce a term K_u such that

$$K_u = \frac{\omega_r}{\omega_s} \quad (3.7)$$

Using 3.7 we can rewrite expressions for positive and negative sequence slips given by equations 3.5 and 3.6 respectively as

$$s^p = 1 - K_u \quad (3.8)$$

And,

$$s^n = 1 + K_u \quad (3.9)$$

The advantage of using K_u is that the response of the machine can now be studied based on one variable instead of the two slips. The impact of asymmetry on the machine is discussed below.

3.6.1 Torque

From the equivalent circuit of the machine shown in Figure 2.4 in chapter 2, the square of the rms of rotor current can be approximated as:

$$I_r'^2 = \frac{V_s^2}{\left(\frac{R_r'}{s}\right)^2 + (X_r')^2} \quad (3.10)$$

The air gap power can be written as

$$P_g = \text{no of phases} * \text{eqv rotor resistance} * (\text{stator current})^2 \quad (3.11)$$

Or,

$$P_g = 3 * \frac{R_r'}{s} * (I_r')^2 \quad (3.12)$$

Using 3.10 above, 3.12 can be rewritten as

$$P_g = \frac{3 R_r' V_s^2}{s \left\{ \left(\frac{R_r'}{s}\right)^2 + (X_r')^2 \right\}} \quad (3.13)$$

All the variables we are using to represent the rotor quantities are referred to the primary side.

Thus for the simplicity of expressions R_r', X_r' and I_r' by R_r, X_r and I_r respectively. 3.13 can be rewritten as

$$P_g = \frac{3 R_r V_s^2}{s \left\{ \left(\frac{R_r'}{s}\right)^2 + (X_r')^2 \right\}} \quad (3.13a)$$

Formula 3.13a is valid when machine is supplied with symmetrical voltages. In case of asymmetrical voltages when the voltage is separated into positive and negative sequence

components, the total power crossing the air gap of the machine can be written as the sum of the power due to the positive sequence and the negative sequence. In other words,

$$P_g = P_g^p + P_g^n, \quad (3.14)$$

Where,

$$P_g^p = \frac{3 R_r (V_s^p)^2}{s^p \left\{ \left(\frac{R_r}{s^p} \right)^2 + (X_r)^2 \right\}} \quad (3.15)$$

And,

$$P_g^n = \frac{3 R_r (V_s^n)^2}{s^n \left\{ \left(\frac{R_r}{s^n} \right)^2 + (X_r)^2 \right\}} \quad (3.16)$$

We know that the torque is given by the formula,

$$T = \frac{P_g}{\omega_s} \quad (3.17)$$

The torque is dependent on the air gap power and the synchronous frequency. When the voltages are separated into positive and negative sequence component voltages, both the voltages will produce their respective torques. The torque due to the positive sequence is

$$T^p = \frac{P_g^p}{\omega_s} = \frac{3 R_r (V_s^p)^2}{s^p \omega_s \left\{ \left(\frac{R_r}{s^p} \right)^2 + (X_r)^2 \right\}} \quad (3.18)$$

And the torque due to the negative sequence is

$$T^n = \frac{P_g^n}{-\omega_s} = \frac{-3 R_r (V_s^n)^2}{s^n \omega_s \left\{ \left(\frac{R_r}{s^n} \right)^2 + (X_r)^2 \right\}} \quad (3.19)$$

The positive sequence torque is in the same direction as governed by the supplied voltages while the negative sequence torque is in the opposite direction. This means there will be a reduction in the overall torque when the supply is asymmetrical.

The total torque,

$$T = T^p + T^n \quad (3.20)$$

Or

$$T = \frac{3 R_r (V_s^p)^2}{s^p \omega_s \left\{ \left(\frac{R_r}{s^p} \right)^2 + (X_r)^2 \right\}} - \frac{3 R_r (V_s^n)^2}{s^n \omega_s \left\{ \left(\frac{R_r}{s^n} \right)^2 + (X_r)^2 \right\}} \quad (3.21)$$

The first part of 3.21 is the torque due to the positive sequence. It is same as the torque when the supply is symmetrical. The second part gives the torque due to the negative sequence. It is clear that as the asymmetry increases, V_s^n also increases meaning a bigger reduction in the overall torque. Because of the two components of torque, the machine is subjected to torque pulsations.

If we recall,

$$s^p = 1 - K_u \quad (3.22)$$

And,

$$s^n = 1 + K_u \quad (3.23)$$

Replacing formula 3.22 and 3.23 in formula 3.21 and rearranging, we get

$$T = \frac{3 R_r}{\omega_s} \left(\frac{(V_s^p)^2}{(1 - K_u) \left\{ \left(\frac{R_r}{1 - K_u} \right)^2 + (X_r)^2 \right\}} - \frac{(V_s^n)^2}{(1 + K_u) \left\{ \left(\frac{R_r}{1 + K_u} \right)^2 + (X_r)^2 \right\}} \right) \quad (3.24)$$

Upon simplification formula 3.24 becomes

$$T = \left(\frac{3 R_r (V_s^p)^2 (1 - K_u)}{\omega_s \{ (R_r)^2 + (1 - K_u)^2 (X_r)^2 \}} - \frac{3 R_r (V_s^n)^2 (1 + K_u)}{\omega_s \{ (R_r)^2 + (1 + K_u)^2 (X_r)^2 \}} \right) \quad (3.25)$$

If we recall at a motor start, $s_p = 1$ meaning $K_u = 0$. If we replace $K_u = 0$ in 3.25

$$T_{start} = \left(\frac{3 R_r (V_s^p)^2}{\omega_s \{ (R_r)^2 + (X_r)^2 \}} - \frac{3 R_r (V_s^n)^2}{\omega_s \{ (R_r)^2 + (X_r)^2 \}} \right) \quad (3.26)$$

Recalling machine theory, the starting torque when the supply is symmetrical is given by

$$T_s = \frac{3 R V^2}{\omega (R^2 + X^2)} \quad (3.27)$$

Comparing formula 3.26 with 3.27, it is evident that the first part of 3.26 which is the torque due to positive sequence is similar to torque in 3.27. The second part of 3.26 is introduced due to asymmetry. Since this part is negative; it means that there is reduction in the starting torque produced by the machine. Also, it is evident that the negative component increases with increases in asymmetry because it has $(V_s^n)^2$ present in the numerator. Thus, if the supply voltage is asymmetrical, there is reduction in the starting torque that is produced by the machine.

3.6.2 Rotor Currents

The square of the rms of rotor current can be approximated as:

$$I_r^2 = \frac{V_s^2}{\left(\frac{R_r}{s}\right)^2 + (X_r)^2} \quad (3.28)$$

If we consider the positive and negative sequence currents, then we will have

$$(I_r^p)^2 = \frac{(V_s^p)^2}{\left(\frac{R_r}{s^p}\right)^2 + (X_r)^2} \quad (3.29)$$

And,

$$(I_r^n)^2 = \frac{(V_s^n)^2}{\left(\frac{R_r}{s^n}\right)^2 + (X_r)^2} \quad (3.30)$$

Referring to the rotor current for the positive sequence given by 3.29, value of s^p is in the range of .02 during normal operation. This makes $\left(\frac{R_r}{s^p}\right)$ much greater than R_r . Since R_r and X_r are in the same range, the denominator can be approximated by $(50R_r)^2$. This high impedance limits the rotor current. For the same reason, since the positive sequence slip is 1 at the start, the machine draws high starting current.

Referring to 3.30, the equivalent rotor resistance is $\left(\frac{R_r}{s^n}\right)$. But s^n is close to 2 during normal operation. Thus the equivalent negative sequence rotor resistance $\left(\frac{R_r}{s^n}\right)$ is $(.5R_r)$. The denominator is thus approximately equal to $(1.1R_r)^2$. This is much smaller compared to the positive sequence equivalent rotor impedance. Thus even a small negative sequence voltage will also cause a high amount of negative sequence current to flow in the rotor. We can also look at this from the locked rotor operation of induction machines. The negative sequence current is always high because the machine always draws starting current from the point of view of the negative sequence voltage.

Using $s^p = 1 - K_u$ and $s^n = 1 + K_u$ in formula 3.29 and 3.30 above, we get

$$(I_r^p)^2 = \frac{(V_s^p)^2}{\left(\frac{R_r}{1 - K_u}\right)^2 + (X_r)^2} \quad (3.31)$$

And,

$$(I_r^n)^2 = \frac{(V_s^n)^2}{\left(\frac{R_r}{1 + K_u}\right)^2 + (X_r)^2} \quad (3.32)$$

Taking the ratio of negative and positive sequence rotor currents, we get

$$\frac{(I_r^n)^2}{(I_r^p)^2} = \left(\frac{V_s^n}{V_s^p}\right)^2 * \frac{\left(\frac{R_r}{1-K_u}\right)^2 + (X_r)^2}{\left(\frac{R_r}{1+K_u}\right)^2 + (X_r)^2} \quad (3.33)$$

The ratio of the two currents given by 3.33 is dependent on the degree of asymmetry given by the ratio $\left(\frac{V_s^n}{V_s^p}\right)^2$. However; it is also dependent on K_u which relates to positive and negative sequence slips. The negative and positive sequence slips are dependent on torques and the equations governing them are very complex. Thus, the exact correlation between the ratios of rotor currents to percent unbalance can only be calculated using simulation when other parameters are known. This is presented in the fifth chapter.

3.6.3 Losses

In the preceding sections it was shown how the overall torque is reduced when machine is subjected to asymmetrical voltage supply. This is because the negative sequence torque is in the opposite direction of the positive sequence torque. In order to produce the required torque to balance the load torque, the machine has to produce extra positive sequence torque. For the same supply voltage, this will mean an increment in the rotor current and the operating slip.

If we recall machine theory, the losses in the motor mainly occur in the rotor and the stator circuit. Since the losses in the stator circuit are small compared to those in the rotor circuit, they are ignored in calculations. The losses can be related to the air gap power as

$$\Delta P = s P_g \quad (3.34)$$

For the positive sequence circuits,

$$\Delta P^p = s^p P_g^p = \frac{3 R_r (V_s^p)^2}{\left\{ \left(\frac{R_r}{s^p}\right)^2 + (X_r)^2 \right\}} \quad (3.35)$$

Since the positive sequence torque is responsible for producing the torque to balance the load torque and the negative sequence torque, it has to increase when there is asymmetrical supply. And since the torque is related to the slip, the slip also increases. Thus, more the asymmetry more will be the losses in the positive sequence circuit.

The losses in the rotor circuit can also be related to the rotor current as

$$\Delta P = 3 * R_r * I_r^2. \quad (3.36)$$

For positive sequence rotor current,

$$\Delta P^p = 3 * R_r * (I_r^p)^2 \quad (3.37)$$

So it follows that when the rotor currents are increased in order to produce a higher torque, there is increment in the rotor current. This leads to increased losses as given by 3.37.

Losses occurring in the positive sequence circuit were discussed above. The losses occurring in the negative sequence circuit are much higher. If we recall, the negative sequence component cannot contribute to energy delivery in the positive direction. So the negative sequence power crossing the air gap totally contributes to the losses. Thus the total losses occurring in the negative sequence circuit is given by:

$$\Delta P^n = P_g^n = \frac{3 R_r (V_s^n)^2}{s^n \left\{ \left(\frac{R_r}{s^n} \right)^2 + (X_r)^2 \right\}} \quad (3.38)$$

Combining 3.35 and 3.38, the total losses occurring in the machine is given by

$$\Delta P = \frac{3 R_r (V_s^p)^2}{\left\{ \left(\frac{R_r}{s^p} \right)^2 + (X_r)^2 \right\}} + \frac{3 R_r (V_s^n)^2}{s^n \left\{ \left(\frac{R_r}{s^n} \right)^2 + (X_r)^2 \right\}} \quad (3.39)$$

It is clear from 3.39 that asymmetry increases the losses in the machine. The exact correlation of losses and asymmetry can only be found when the positive and negative sequence slips are

found. According to [7], 6.35 percent asymmetry increases the losses by 50 percent. It is mentioned that the percent increase in temperature rise is approximately two times the increment in percent asymmetry. When there is increment in losses due to asymmetry, it tends to increase the temperature of the machine. As a result, the resistance of the windings is also increased because of the temperature resulting in a further increment in the losses. Eventually equilibrium is reached at a higher temperature. Details of this can be found in Ref [8]. The correlation between percent asymmetry and machine losses, obtained through simulation is presented in the fifth chapter of this thesis.

3.6.4 Efficiency

When supplied with asymmetrical voltages, the losses in the machine are increased and this leads to the reduction of efficiency. Mathematically, efficiency is given by the formula

$$\eta = \frac{P_{out}}{P_{in}} \quad (3.40)$$

In case of an induction machine, the total output power can be found by subtracting the losses from the input power. The total input power is the power crossing the air gap. It is the sum of the positive and negative sequence air gap powers, viz.

$$P_{in} = P_g^p + P_g^n \quad (3.41)$$

The losses occurring in the positive sequence circuit are given by:

$$\Delta P^p = s^p * P_g^p \quad (3.42)$$

Likewise, based on the previous section, the losses occurring in the negative sequence circuit are given by:

$$\Delta P^n = P_g^n \quad (3.43)$$

Thus the total losses occurring in the machine is given by

$$\Delta P = \Delta P^p + \Delta P^n = s^p * P_g^p + P_g^n \quad (3.44)$$

If we recall machine theory, the total output power of the machine can be calculated by subtracting the losses from the input power. Thus,

$$P_{out} = P_{in} - \Delta P \quad (3.45)$$

Or,

$$P_{out} = P_g^p + P_g^n - (s^p * P_g^p + P_g^n) = P_g^p - s^p * P_g^p \quad (3.46)$$

Thus, the output power produced by the machine is

$$P_{out} = (1 - s^p) * P_g^p \quad (3.47)$$

The efficiency of the machine can be calculated as:

$$\eta = \frac{P_{out}}{P_{in}} = \frac{(1 - s^p) * P_g^p}{P_g^p + P_g^n} \quad (3.48)$$

Replacing 3.15 and 3.16 in 3.48 we get,

$$\eta = (1 - s^p) * \left(\frac{\frac{3 R_r (V_s^p)^2}{s^p \left\{ \left(\frac{R_r}{s^p} \right)^2 + (X_r)^2 \right\}}}{\left(\frac{3 R_r (V_s^p)^2}{s^p \left\{ \left(\frac{R_r}{s^p} \right)^2 + (X_r)^2 \right\}} \right) + \left(\frac{3 R_r (V_s^n)^2}{s^n \left\{ \left(\frac{R_r}{s^n} \right)^2 + (X_r)^2 \right\}} \right)} \right) \quad (3.49)$$

Or,

$$\eta = (1 - s^p) * \left(\frac{\frac{(V_s^p)^2}{s^p \left\{ \left(\frac{R_r}{s^p} \right)^2 + (X_r)^2 \right\}}}{\left(\frac{(V_s^p)^2}{s^p \left\{ \left(\frac{R_r}{s^p} \right)^2 + (X_r)^2 \right\}} \right) + \left(\frac{(V_s^n)^2}{s^n \left\{ \left(\frac{R_r}{s^n} \right)^2 + (X_r)^2 \right\}} \right)} \right) \quad (3.50)$$

Therefore,

$$\eta = \frac{(1 - s^p)}{1 + \left(\left(\frac{V_s^n}{V_s^p} \right)^2 \frac{s^p \left\{ \left(\frac{R_r}{s^p} \right)^2 + (X_r)^2 \right\}}{s^n \left\{ \left(\frac{R_r}{s^n} \right)^2 + (X_r)^2 \right\}} \right)} \quad (3.51)$$

It is clear from 3.51 that when asymmetry is zero, the efficiency reduces to $(1 - s^p)$, which is the standard efficiency for induction machines supplied with symmetrical voltages. Asymmetry reduces the efficiency in two ways. First is by reducing the numerator. When supply voltage is asymmetrical, there is reduction in the speed of the machine to meet the load requirements. Thus the slip increases and the term $(1 - s^p)$ in the numerator of 3.51 reduces. Second, as the level of asymmetry increases, the denominator of 3.51 also increases thereby causing the efficiency to reduce. The exact correlation between asymmetry and efficiency is shown in chapter 5.

3.6.5 Life expectancy and de-rating of machines

Heat dissipation in the machine increases with the losses. A machine is designed to withstand certain temperature and the insulation is also designed accordingly. When there is temperature rise over the design limit, the insulation of the machine will be damaged over time and the machine will eventually break down. Thus the life expectation of machine is also negatively affected when supplied with asymmetrical voltages. This issue studied in reference [11].

To address this problem, higher class of insulation has to be used. Likewise, since efficiency is related to output power, to get the same output power, a higher input power is needed when the efficiency is low. In other words, a bigger size of machine is needed to do equal amount of work. This means machines have to be de-rated which increases the costs. De-rating of machines is studied more thoroughly in Ref [10].

CHAPTER 4: OPERATION OF INDUCTION MACHINES UNDER DISTORTED SUPPLY VOLTAGE

4.1 Introduction

Voltages and currents in the power system are usually distorted. An ideal supply voltage is supposed to be symmetrical and sinusoidal. If it deviates from that, then the supply quality is said to have been degraded. In such situations, the theory of induction machines presented in chapter 2 becomes invalid. The theory of an induction machine operating under nonsinusoidal supply voltages is presented in this chapter. It is assumed that the supply voltages are symmetrical.

Our focus is on the distortion of voltages and currents in the power system. In the ideal case these can be represented as sinusoidal quantities. Thus the scope of our definitions will be limited to distortion of sinusoidal quantities. For the same reason, the words distorted and nonsinusoidal are often described for sinusoidal quantities when used in the power system. For the rest of the thesis, distortion will refer to distortion of sinusoidal quantities.

4.2 Types and causes of voltage and current distortion

In the general sense, waveform distortion could be caused by the supply, by the load or by both of them. When the current is distorted due to the harmonics generated in the load, it is referred to as distortion due the deterioration of the loading quality. Likewise, when a distortion is caused by the supply, then the supply quality is said to have been deteriorated. Just like how asymmetrical voltages and asymmetrical currents are interrelated, voltage and current distortion are also intertwined. Voltage distortion leads to current distortion and vice versa. Therefore when studying the impacts of voltage distortion on induction machines, it is an imperative that the impacts of current distortion also be included in the analysis. The causes of voltage and current distortion are briefly described in this section.

4.2.1 Distortions originating at the generation level

Windings in synchronous generators are not distributed evenly. This can lead to generation of nonsinusoidal voltage. However, generators are designed to mitigate this problem as much as possible. As a result, voltage distortion caused by synchronous generators is well below .5% and can be neglected. The case is different when the source of energy is wind generators. These are normally connected to the power system via variable frequency converters and power electronic interfaces which do not produce perfectly sinusoidal voltages. As a result, voltages provided by wind generators are more distorted than the voltage produced by synchronous generators.

4.2.2 Interaction of voltage and current distortion

When the current is distorted, it causes nonsinusoidal voltage drop on the system impedance. This in turn causes distortion of the system voltage. This means that even when the supply quality is ideal, distorted current caused by the load generated harmonics causes nonsinusoidal voltage drop in the power system, eventually leading to voltage distortion. Moreover, the supply voltage distortion can distort the load current, which in turn increases the voltage distortion. Thus there is a feedback that increases both current and voltage distortion.

Similarly, high amount of current distortion can result from a harmonic resonance in the power system. The power system impedance is mostly inductive. Therefore, capacitors that are used in the circuit for compensation can resonate with the system impedance. Even the capacitance of lines can contribute to this phenomenon when the length of the line is comparable to a quarter of the wavelength of the harmonic. This means that a small distortion in the supply voltage might lead to harmonic content amplification in the voltage and current.

4.2.3 Nonlinear loads

Some loads in the power system are nonlinear by nature. Components of power electronics devices, like diodes and thyristors, are nonlinear devices. They can draw highly distorted current and cause current distortion. Fluorescent lamps also lead to current distortion. A major source of harmonics in some areas are arc furnaces as they draw extremely high amount of distorted currents. Any load that causes current distortion is generally known as a Harmonic Generating Load (HGL).

4.3 Mathematical representation of a distorted quantity

Distortion of periodic quantities can be regarded as a superimposition of higher order harmonics on the fundamental component. Figure 4.1 shows a distorted quantity, where the fundamental component is superimposed by the 7th order harmonic. The fundamental component is the dominating component and has the same frequency as the resulting quantity. The 7th order harmonic component shown is 4.1 has angular frequency seven times higher than the fundamental frequency. It is evident that the harmonic component does not affect the frequency of the resultant quantity.

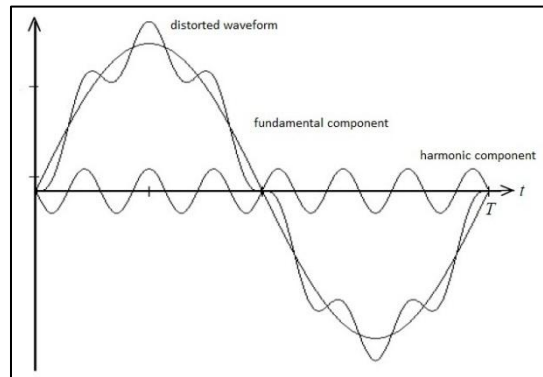

Figure 4.1: Representation of a distorted quantity as the sum of two sinusoidal quantities

When a sinusoidal quantity is distorted, it is convenient to describe it using a Fourier series, namely

$$v(t) = a_0 + \sum_{n=1}^{\infty} a_n \cos n\omega_1 t + \sum_{n=1}^{\infty} b_n \sin n\omega_1 t \quad (4.1)$$

Since

$$e^{jn\omega_1 t} = \cos(n\omega_1 t) + j \sin(n\omega_1 t) \quad (4.2)$$

thus,

$$\cos(n\omega_1 t) = \text{Re}\{e^{jn\omega_1 t}\}, \quad \sin(n\omega_1 t) = \text{Re}\{-je^{jn\omega_1 t}\}. \quad (4.3)$$

Thus (4.1) can be expressed as

$$v(t) = a_0 + \sum_{n=1}^{\infty} a_n \text{Re}\{e^{jn\omega_1 t}\} + \sum_{n=1}^{\infty} b_n \text{Re}\{-je^{jn\omega_1 t}\} \quad (4.4)$$

or

$$v(t) = a_0 + \sqrt{2} \text{Re} \sum_{n=1}^{\infty} \frac{a_n - j b_n}{\sqrt{2}} \{e^{jn\omega_1 t}\} \quad (4.5)$$

where a_0 is the dc component of the quantity.

Let

$$V_0 = a_0 = \frac{1}{T} \int_0^T x(t) dt, \quad V_n = \frac{a_n - j b_n}{\sqrt{2}} \quad (4.6)$$

The Fourier series given by (4.5) can thus be written as

$$v(t) = V_0 + \sqrt{2} \text{Re} \sum_{n=1}^{\infty} V_n e^{jn\omega_1 t} \quad (4.7)$$

(4.7) is referred to as the complex form of Fourier series.

The complex coefficient

$$V_n = V_n e^{j\alpha_n} = \frac{\sqrt{2}}{T} \int_0^T v(t) e^{-jn\omega_1 t} dt \quad (4.8)$$

is known as the complex rms (CRMS) value of the n^{th} order. Its magnitude is equal to the rms value of harmonic V_n and its phase angle is equal to the phase angle α_n of the n^{th} harmonic.

(4.8) can be expanded as

$$v(t) = V_0 + \sqrt{2} \operatorname{Re} \{ V_1 e^{j\omega_1 t} + V_2 e^{j2\omega_1 t} + V_3 e^{j3\omega_1 t} \dots V_n e^{jn\omega_1 t} \} \quad (4.9)$$

In Eqn. (4.9) above, the angular frequencies $\omega_2, \omega_3 \dots \omega_n$ which are integral multiples of ω_1 are replaced by $n\omega_1$ where n is the order of the harmonic. For any harmonic component of $v(t)$, V_n is the rms value, α_n is the phase angle and $n\omega_1$ is the angular frequency. The term $\sqrt{2} \operatorname{Re} V_1 e^{jn\omega_1 t}$ is the fundamental component of $v(t)$ and V_0 is the dc component of $v(t)$. The remaining components of Eqn. (4.9) are the harmonics. The fundamental component is usually the dominating component of any distorted quantity and the frequency of the fundamental component determines the frequency of the total quantity. As a matter of fact, if there is no distortion, a quantity is solely composed of the fundamental component. In that sense, distortion can be considered as the superimposition of harmonics on the fundamental component. It is to be noted though that harmonics are only mathematical entities that are used for better mathematical description of quantities and do not exist in the physical sense. When a quantity is distorted, it does not mean it is physically comprised superimposed quantities; rather it just means that mathematically it can be better expressed as a sum of a certain number of harmonics of different order and magnitudes. Eqn. (4.9) represents a single phase quantity. Three phase quantities could be expressed in the same way.

Assuming that the three phase voltages are symmetrical periodic quantities, we can write

$$v_S(t) = v_R \left(t - \frac{T}{3} \right), \quad v_T(t) = v_R \left(t + \frac{T}{3} \right) \quad (4.10)$$

Using the shifting property of harmonics discussed in Ref [15], the CRMS of voltage v_s of the n^{th} harmonic can be written as

$$V_{Sn} = 1 e^{-jn\omega_{1/3}T} V_{Rn} = 1 e^{-jn120} V_{Rn} \quad (4.11)$$

Since

$$1 e^{-jn120} = \begin{cases} \alpha^* & \text{for } n = 1,4,7 \dots \dots 3k + 1 \\ 1 & \text{for } n = 3,6,9 \dots \dots 3k \\ \alpha & \text{for } n = 2,5,8 \dots \dots 3k - 1 \end{cases} \quad (4.11a)$$

Thus,

$$V_{Sn} = \begin{cases} \alpha^* V_{Rn}, & \text{for } n = 1,4,7 \dots \dots 3k + 1 \\ V_{Rn}, & \text{for } n = 3,6,9 \dots \dots 3k \\ \alpha V_{Rn}, & \text{for } n = 2,5,8 \dots \dots 3k - 1 \end{cases} \quad (4.12)$$

Similarly the CRMS of n^{th} harmonic of v_T can be written as

$$V_{Tn} = e^{jn\omega_{1/3}T} V_{Rn} = e^{jn120} V_{Rn} \quad (4.13)$$

Since

$$1 e^{jn120} = \begin{cases} \alpha & \text{for } n = 1,4,7 \dots \dots 3k + 1 \\ 1 & \text{for } n = 3,6,9 \dots \dots 3k \\ \alpha^* & \text{for } n = 2,5,8 \dots \dots 3k - 1 \end{cases} \quad (4.13a)$$

Thus,

$$V_{Tn} = \begin{cases} \alpha V_{Rn}, & \text{for } n = 1, 4, 7 \dots 3k + 1 \\ V_{Rn}, & \text{for } n = 3, 6, 9 \dots 3k \\ \alpha^* V_{Rn}, & \text{for } n = 2, 5, 8 \dots 3k - 1 \end{cases} \quad (4.14)$$

Using Eqns. (4.12) and (4.14) that voltage harmonics for the order of $3k + 1$ can be expressed as

$$v_n = \sqrt{2} \operatorname{Re} \begin{bmatrix} V_{Rn} \\ V_{Sn} \\ V_{Tn} \end{bmatrix} e^{j\omega_1 t} = \sqrt{2} \operatorname{Re} \begin{bmatrix} 1 \\ \alpha^* \\ \alpha \end{bmatrix} V_{Rn} e^{j\omega_1 t} \quad (4.15)$$

The voltage harmonics for the order of $3k$ and $3k-1$ can be calculated similarly. The total voltage can thus be expressed as

$$v_n = \begin{cases} \sqrt{2} \operatorname{Re} \begin{bmatrix} 1 \\ \alpha^* \\ \alpha \end{bmatrix} V_{Rn} e^{j\omega_1 t} & \text{for } n = 3k + 1 \\ \sqrt{2} \operatorname{Re} \begin{bmatrix} 1 \\ 1 \\ 1 \end{bmatrix} V_{Rn} e^{j\omega_1 t} & \text{for } n = 3k \\ \sqrt{2} \operatorname{Re} \begin{bmatrix} 1 \\ \alpha \\ \alpha^* \end{bmatrix} V_{Rn} e^{j\omega_1 t} & \text{for } n = 3k - 1 \end{cases} \quad (4.16)$$

We can conclude from (4.16) that the harmonics of the order $3k+1$ are of the positive sequence, those of order $3k$ are of the zero sequence, while the harmonics of order $3k - 1$ are of the negative sequence. Since we are analyzing a machine which is supplied from three wires with symmetrical voltages, zero sequence components are absent. Thus, the total voltage

$$v = \sum_{n \in N^P} v_n + \sum_{n \in N^N} v_n \quad (4.17)$$

Using similar analysis the expression for distorted current can be presented as

$$i(t) = I_0 + \sqrt{2} \operatorname{Re} \sum_{n=1}^{\infty} I_n e^{jn\omega_n t}. \quad (4.18)$$

4.4 Measures of voltage and current distortion

The most widely accepted and commonly used measure of distortion is the Total Harmonic Distortion (THD). It is calculated by comparing the RMS of the harmonic contents to the RMS of the fundamental.

$$\delta_u = \frac{\|v_h\|}{U_1}, \quad \delta_i = \frac{\|i_h\|}{I_1}. \quad (4.19)$$

Since the harmonics of different order are orthogonal to each other, the RMS of the distorted component of voltage can be calculated as

$$\|v_h\| = \sqrt{V_2^2 + V_3^2 \dots V_n^2} = \sqrt{\sum_{n=2}^{\infty} V_n^2} \quad (4.20)$$

where $V_2, V_3 \dots V_n$ are the values of the voltage harmonics. If V_1 is the RMS of the fundamental component of the voltage, then the THD for voltage is given by

$$\delta_u = \frac{\sqrt{\sum_{n=2}^{\infty} V_n^2}}{V_1} \quad (4.21)$$

The THD for current can be similarly calculated as

$$\delta_i = \frac{\sqrt{\sum_{n=2}^{\infty} I_n^2}}{I_1} \quad (4.22)$$

4.5 Limitations of the single phase equivalent circuit of induction machines

It was discussed in the previous chapter why the single phase equivalent circuit of induction machine presented in chapter 2 (Figure 4.2) is inadequate to represent a machine when the supply voltage is asymmetrical. A similar situation will occur when the supply voltage is

nonsinusoidal. The single phase equivalent circuit of induction machine as presented in chapter 2 is shown in Figure 4.2.

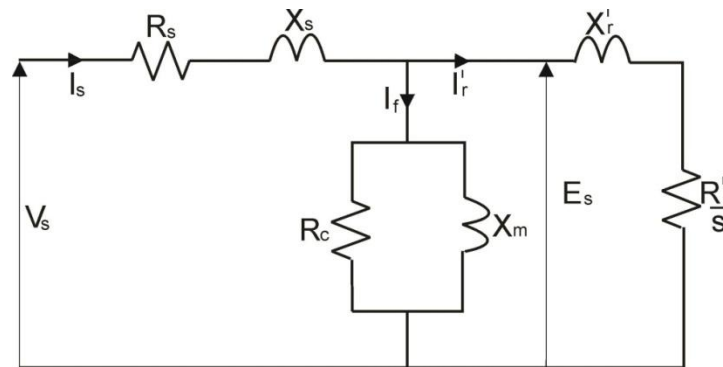

Figure 4.2: Single phase equivalent circuit of induction machine for sinusoidal symmetrical supply voltages

When the source voltage is sinusoidal, the supply voltage is composed of only the fundamental component. Figure 4.2 is sufficient for analysis of the motor properties. When the supply voltage is distorted, the supply voltage harmonics produce harmonic currents and torque. Total current response is the sum of the harmonic currents and the fundamental current. Likewise, the total torque is found by adding the torques produced by the fundamental and the harmonics.

4.6 Equivalent circuit of the machine under symmetrical distorted supply voltage

Harmonics in the power system can be of positive, zero and negative sequence. For the scope of our study, we are focusing on a machine supplied with symmetrical three phase voltages, fed from a three wire system without a neutral. So the zero sequence components do not exist in the supply voltage. Thus we do not need to consider harmonics of the order that are the integral multiples of 3. Similarly the even order harmonics contribute much less to the overall distortion than odd order harmonics. Consequently, they can be ignored from practical considerations. The dominating harmonics in the power system are 5th and 7th order harmonics. The 5th order

harmonic is negative sequence while the 7th order harmonic is positive sequence. If we study these two harmonics, we can have an idea of how a machine responds to a distorted supply voltage.

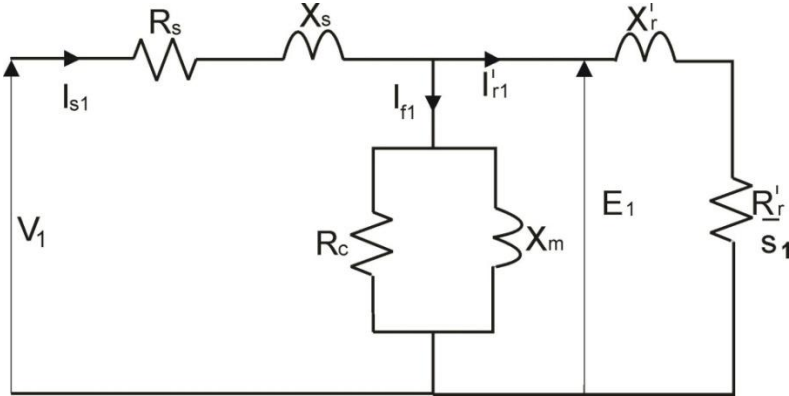

Figure 4.3: Single phase equivalent circuit of induction machine for the fundamental component

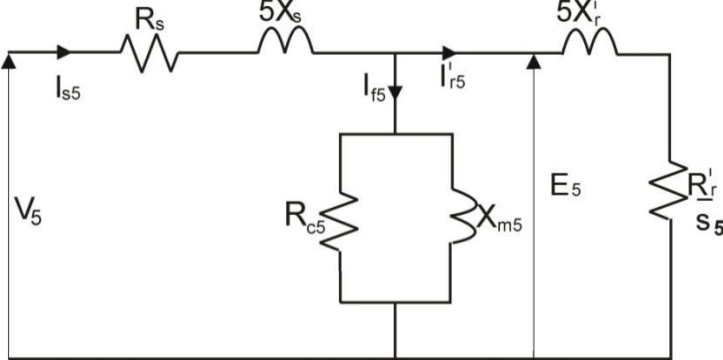

Figure 4.4: Single phase equivalent circuit of induction machine for the fifth harmonic component

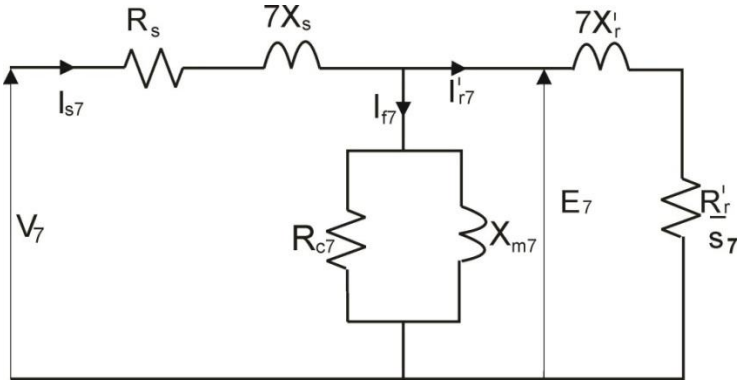

Figure 4.5: Single phase equivalent circuit of induction machine for the seventh harmonic component

Figure 4.3 shows the equivalent circuit of a machine for the fundamental frequency. Figure 4.4 shows the equivalent circuit for the 5th order harmonics while Figure 4.5 represents the same for the 7th order harmonic. One can observe that the supply voltage and the equivalent rotor resistance vary for different harmonic order. Since the inductive reactance are dependent on the supply frequency, reactance X'_r , X_m and X_s change for the n^{th} order harmonic to nX'_r , nX_m and nX_s respectively. The stator winding resistance R_s is independent of supply frequency assuming that the skin effect is negligible. However the stator core equivalent magnetic resistance depends on the harmonic order because the power loss in the core changes with frequency. Note that the stator side voltage is only shown for phase A in all the cases. Assuming that the supply voltage is symmetrical, one phase of the machine is sufficient in representing all three phases.

It is to be noted that the skin effects on the rotor conductors are ignored during the analysis presented in this thesis. Skin effects can potentially become significant as the frequency of the rotor currents increases. To find the change in the resistance due to the skin effect, the exact dimensions, size and specification of the motor is required. It is hard to study the effects without knowing the exact geometry of the machine. Since the analysis presented in this thesis is done for the general sense, it becomes hard to incorporate skin effects into the analysis.

4.7 Analysis of machine performance under distorted supply voltage

Analysis of the machine will be confined to only the 5th and 7th order harmonics in addition to the fundamental component. These are the two most dominant harmonics in the power system. When effects of these two harmonics are analyzed, other harmonics can be analyzed in a similar way.

The 5th order harmonic produces a rotating field that rotates five times as fast as the rotor but in the opposite direction. On the other hand, the 7th order harmonic produces a rotating field

that rotates seven times as fast as the fundamental in the same direction. In both cases, the relative angular frequency of the rotating field is six times the synchronous frequency of the fundamental. Both of them try to rotate the machine at their respective synchronous speeds. Based on the level of distortion, they draw currents at their respective frequencies and this current leads to losses and changes in torque among others.

Let us recall the slip,

$$s = \frac{\omega_s - \omega_r}{\omega_s} \quad (4.23)$$

The slip of the fundamental component is,

$$s_1 = \frac{\omega_1 - \omega_r}{\omega_1} = 1 - \frac{\omega_r}{\omega_1} \quad (4.24)$$

where ω_1 is angular frequency of the fundamental component. Similarly, the frequency at which the rotating field produced by the fifth harmonic component rotates is $-5\omega_1$. Thus the slip for the 5th harmonic component is

$$s_5 = \frac{\omega_5 - \omega_r}{\omega_5} = \frac{-5\omega_1 - \omega_r}{-5\omega_1} = 1 + \frac{\omega_r}{5\omega_1}. \quad (4.25)$$

Likewise the frequency at which the rotating field produced by the seventh harmonic component rotates is $7\omega_1$. The slip for the 7th harmonic component is given by,

$$s_7 = \frac{\omega_7 - \omega_r}{\omega_7} = \frac{7\omega_1 - \omega_r}{7\omega_1} = 1 - \frac{\omega_r}{7\omega_1}. \quad (4.26)$$

Let us now introduce a term K_h such that

$$K_h = \frac{\omega_r}{\omega_1} \quad (4.27)$$

Using Eqn. (4.27) we can rewrite expressions for the slips given in Eqns. (4.24) to (4.26) as

$$s_1 = 1 - K_h \quad (4.28)$$

$$s_5 = 1 + \frac{K_h}{5} \quad (4.29)$$

and,

$$s_7 = 1 - \frac{K_h}{7} \quad (4.30)$$

The advantage of using K_h is that the response of the machine can now be studied based on one variable. The impact of distortion on the machine performance is discussed below.

4.7.1 Torque

The square of the magnitude of rotor current can be approximated from the equivalent circuit of the machine shown in Figure 4.2 as:

$$I_r'^2 = \frac{V_s^2}{\left(\frac{R_r'}{s}\right)^2 + (X_r')^2} \quad (4.31)$$

The current and impedance in Eqn. (4.31) are rotor quantities referred to the stator side, while the voltage is on the stator side. For the sake of simplicity, we will replace the quantities I_r', R_r', X_r' and V_s with I, R_r, X_r and V respectively. Eqn. (4.31) can be rewritten as:

$$I^2 = \frac{V^2}{\left(\frac{R_r}{s}\right)^2 + (X_r)^2} \quad (4.32)$$

Referring to Chapter 2, the air gap power is given by

$$P_g = \frac{3 R_r V^2}{s \left\{ \left(\frac{R_r}{s}\right)^2 + (X_r)^2 \right\}} \quad (4.33)$$

Eqn. (4.33) is valid when machine is supplied with sinusoidal voltages. When the voltage is distorted and separate circuit are analyzed for the individual harmonics, the total power crossing the air gap is due to the contribution of all the harmonics. Thus the total air gap power is:

$$P_g = P_{g1} + P_{g5} + P_{g7} \quad (4.34)$$

Since we are only dealing with air gap active power in our analysis; the air gap power can be represented by "P" without causing any ambiguity. Thus,

$$P = P_1 + P_5 + P_7 \quad (4.35)$$

where,

$$P_1 = \frac{3 R_r V_1^2}{s_1 \left\{ \left(\frac{R_r}{s_1} \right)^2 + (X_r)^2 \right\}} \quad (4.36)$$

Similarly,

$$P_5 = \frac{3 R_r V_5^2}{s_5 \left\{ \left(\frac{R_r}{s_5} \right)^2 + (5X_r)^2 \right\}} \quad (4.37)$$

and,

$$P_7 = \frac{3 R_r V_7^2}{s_7 \left\{ \left(\frac{R_r}{s_7} \right)^2 + (7X_r)^2 \right\}} \quad (4.38)$$

The torque is given by the formula,

$$T = \frac{P}{\omega_s} \quad (4.39)$$

Torque is dependent on the air gap power and the synchronous frequency at which the field produced by the voltage rotates. When the supply voltage contains 5th and 7th order harmonics in addition to the fundamental quantity, it transfers energy through the air gap as given by Eqns.

(4.36) to (4.38) above. All three air gap powers produce their respective torques. The total torque produced by the machine can be found by adding the torques together. The torque due to the fundamental component of voltage is:

$$T_1 = \frac{P_1}{\omega_1} = \frac{3 R_r V_1^2}{\omega_1 s_1 \left\{ \left(\frac{R_r}{s_1} \right)^2 + (X_r)^2 \right\}} \quad (4.40)$$

Torque due to the 5th harmonic component of voltage is:

$$T_5 = \frac{P_5}{\omega_5} = \frac{3 R_r V_5^2}{-5 \omega_1 s_5 \left\{ \left(\frac{R_r}{s_5} \right)^2 + (5X_r)^2 \right\}} \quad (4.41)$$

Torque due to the 7th harmonic component of voltage is:

$$T_7 = \frac{P_7}{\omega_7} = \frac{3 R_r V_7^2}{7 \omega_1 s_7 \left\{ \left(\frac{R_r}{s_7} \right)^2 + (7X_r)^2 \right\}} \quad (4.42)$$

Torque produced by the fundamental component is oriented in the direction as governed by the supply voltages. The 5th order harmonic is a negative sequence component and produces a torque in the opposite direction as the one produced by the fundamental component. The 7th order harmonic component is a positive sequence harmonic and produces torque oriented in the same direction as the fundamental component. The total torque is calculated by adding the individual torques together because the machine can be considered as a linear device. The total torque T is

$$T = T_1 + T_5 + T_7 \quad (4.43)$$

or

$$\begin{aligned}
T = & \frac{3 R_r V_1^2}{\omega_1 s_1 \left\{ \left(\frac{R_r}{s_1} \right)^2 + (X_r)^2 \right\}} - \frac{3 R_r V_5^2}{5 \omega_1 s_5 \left\{ \left(\frac{R_r}{s_5} \right)^2 + (5X_r)^2 \right\}} \\
& + \frac{3 R_r V_7^2}{7 \omega_1 s_7 \left\{ \left(\frac{R_r}{s_7} \right)^2 + (7X_r)^2 \right\}}
\end{aligned} \tag{4.44}$$

The first part of Eqn. (4.44) is the torque produced by the fundamental component. If the supply voltages were sinusoidal, voltage would contain only the fundamental component and all the torque would be produced by the fundamental quantity. However, there is production of torque due to the 5th and 7th harmonic components and the total torque will change. The total torque might be increased or decreased depending upon the values of the torques due to the 5th and 7th order harmonic. It might seem from Eqn. (4.44) that positive sequence harmonics have a positive impact on the machine due to the addition in torque. However, the addition in torque is minimal compared to the losses and efficiency reduction it causes. Even the positive sequence harmonics are harmful to the machine.

Using Eqns. (4.40) to (4.42) above, Eqn. (4.44) can be rewritten as

$$\begin{aligned}
T = & \frac{3 R_r V_1^2}{\omega_1 (1 - K_h) \left\{ \left(\frac{R_r}{1 - K_h} \right)^2 + (X_r)^2 \right\}} - \frac{3 R_r V_5^2}{5 \omega_1 \left(1 + \frac{K_h}{5} \right) \left\{ \left(\frac{R_r}{1 + \frac{K_h}{5}} \right)^2 + (5X_r)^2 \right\}} \\
& + \frac{3 R_r V_7^2}{7 \omega_1 \left(1 - \frac{K_h}{7} \right) \left\{ \left(\frac{R_r}{1 - \frac{K_h}{7}} \right)^2 + (7X_r)^2 \right\}}
\end{aligned} \tag{4.45}$$

The exact value of torque for a certain level of distortion can be calculated using simulation only when the load torque is given. The results of simulation are presented in the fifth chapter.

At a motor start, $s_1 = 1$ or $K_h = 0$. Starting torque is calculated using these values, namely

$$T_{start} = \left(\frac{3 R_r V_1^2}{\omega_1 \{(R_r^2 + X_r^2)\}} - \frac{3 R_r V_5^2}{5\omega_1 \{(R_r^2 + 25X_r^2)\}} + \frac{3 R_r V_7^2}{7\omega_1 \{(R_r^2 + 49X_r^2)\}} \right) \quad (4.46)$$

From machine theory, the starting torque produced by a machine when supplied with sinusoidal voltages is given by

$$T_s = \frac{3 R V^2}{\omega (R^2 + X^2)} \quad (4.47)$$

Comparing Eqns. (4.46) and (4.47), it is evident that the first part of Eqn. (4.46) which is the torque due to the fundamental component is the same as the torque in Eqn. (4.47). The second and the third parts of Eqn. (4.46) are introduced due to distortion. The 5th order harmonic tends to reduce the starting torque while the 7th order harmonic tends to contribute to the starting torque. Thus the overall starting torque may be increased or decreased depending on the values of the torques produced by the 5th and 7th harmonics.

4.7.2 Rotor Currents

Referring to Eqn. (4.32) above, the square of the rms of rotor current was approximated as:

$$I^2 = \frac{V^2}{\left(\frac{R_r}{s}\right)^2 + (X_r)^2} \quad (4.48)$$

The current rms value of the fundamental current is

$$I_1^2 = \frac{V_1^2}{\left(\frac{R_r}{s_1}\right)^2 + (X_r)^2} \quad (4.49)$$

Current rms value of the 5th order harmonic is

$$I_5^2 = \frac{V_5^2}{\left(\frac{R_r}{s_5}\right)^2 + (5X_r)^2} \quad (4.50)$$

and current rms value of the 7th order harmonic is

$$I_7^2 = \frac{V_7^2}{\left(\frac{R_r}{s_7}\right)^2 + (7X_r)^2}. \quad (4.51)$$

Eqn. (4.48) shows that the current is dependent on the stator voltage and rotor impedances. For induction machines, equivalent rotor resistance and inductance are approximately of the same range. For normal operation, Eqn. (4.48) can be roughly approximated as

$$I_1^2 \cong \frac{V_1^2}{\left(\frac{R_r}{s_1}\right)^2 + (R_r)^2} \quad (4.52)$$

Also, during normal operation the slip is in the range of 0.02. Thus the term $\left(\frac{R_r}{s_1}\right)^2$ becomes much greater than the term $(R_r)^2$ and Eqn. (4.52) can be approximated as

$$I_1^2 \cong \frac{V_1^2}{(50R_r)^2}. \quad (4.53)$$

When the motor starts, the slip is 1 and the rotor current rms value is approximated as

$$I_1^2 \cong \frac{V_1^2}{2 R_r^2} \quad (4.54)$$

and therefore the machine draws high current at the start.

During normal operation, slips for the 5th and 7th harmonics can be approximated as 1.2 and 0.8 respectively. Using these values in Eqns. (4.50) and (4.51) and simplifying shows that both 5th and 7th harmonic voltages draw currents in the range of starting current rms value given by Eqn.

(4.54) at all times. Therefore, a small distortion in the supply voltage could lead to a high amount of current distortion. The Total Harmonic Distortion (THD) of current is given as:

$$\delta_i = \frac{\|i_h\|}{I_1} \quad (4.55)$$

Where i_1 and i_h are RMS of fundamental and harmonic current respectively. For our analysis Eqn. (4.55) can be written as

$$\delta_i = \frac{\sqrt{i_5^2 + i_7^2}}{I_1} \quad (4.56)$$

Since all the quantities used in earlier discussion are RMS values, Eqn. (4.56) becomes

$$\delta_i = \frac{\sqrt{\frac{V_5^2}{\left(\frac{R_r}{s_5}\right)^2 + (5X_r)^2} + \frac{V_7^2}{\left(\frac{R_r}{s_7}\right)^2 + (7X_r)^2}}}{\sqrt{\frac{V_1^2}{\left(\frac{R_r}{s_1}\right)^2 + (X_r)^2}}} \quad (4.57)$$

We also know that the THD for voltage is given by

$$\delta_v = \frac{\sqrt{V_5^2 + V_7^2}}{V_1} \quad (4.58)$$

Using Eqns. (4.57) and (4.58) above, the correlation between current and voltage distortion can be found. When numerical values are calculated through computer modeling, it will be easier to see how an induction machine responds to voltage distortion.

4.7.3 Losses

Overall torque produced by the machine depends on the amounts of 5th and 7th order harmonic of voltage. If the torque produced by 5th order harmonic is greater than the torque produced by the

7th order harmonic, the overall torque will be reduced. To produce the required torque in order to meet the load requirement, the fundamental component has to produce higher torque. This is only possible through increment in the slip which increases the losses. If the torque produced by the 7th harmonic is greater than the torque by the 5th order harmonic, there isn't any increment in losses due to reduction of speed. However, the 7th order harmonic increases the losses in the rotor circuit due to the increment in rotor current.

Ignoring the losses in the stator circuit, the losses in the induction machine can be approximated as

$$\Delta P = s P \quad (4.59)$$

The loss due to the fundamental component of current is:

$$\Delta P_1 = s_1 P_1 = \frac{3 R_r V_1^2}{\left\{ \left(\frac{R_r}{s_1} \right)^2 + (X_r)^2 \right\}} \quad (4.60)$$

Similarly, the losses occurring due to the 7th order harmonic of current is:

$$\Delta P_7 = s_7 P_7 = \frac{3 R_r V_7^2}{\left\{ \left(\frac{R_r}{s_7} \right)^2 + (7X_r)^2 \right\}} \quad (4.61)$$

Since the 5th order harmonic is a negative sequence component, all of the energy transferred through the air gap by this component goes to losses. Thus,

$$\Delta P_5 = P_5 = \frac{3 R_r V_5^2}{s_5 \left\{ \left(\frac{R_r}{s_5} \right)^2 + (5X_r)^2 \right\}} \quad (4.62)$$

Total losses occurring in the machine can be found by adding the losses given in Eqns. (4.60) to (4.61) above, namely

$$\Delta P = \Delta P_1 + \Delta P_5 + \Delta P_7 \quad (4.63)$$

or,

$$\Delta P = \frac{3 R_r V_1^2}{\left\{ \left(\frac{R_r}{s_1} \right)^2 + (X_r)^2 \right\}} + \frac{3 R_r V_5^2}{s_5 \left\{ \left(\frac{R_r}{s_5} \right)^2 + (5X_r)^2 \right\}} + \frac{3 R_r V_7^2}{\left\{ \left(\frac{R_r}{s_7} \right)^2 + (7X_r)^2 \right\}} \quad (4.64)$$

Eqn. (4.64) shows how voltage distortion leads to increased losses in the induction machines. Losses can be calculated when the value of slips at a certain load torque are known. This is presented in Chapter 5 of this thesis. The losses occurring in the induction machine due to distorted supply voltage, are studied more thoroughly in Refs. [12] and [13].

4.7.4 Efficiency

The output power of induction machine can be found by subtracting the losses from the input power. The total input power is the power crossing the air gap. Thus,

$$P_{in} = P_1 + P_5 + P_7 \quad (4.65)$$

The losses occurring due to fundamental component is

$$\Delta P_1 = s_1 P_1 \quad (4.66)$$

The output power produced by the fundamental component is $P_1 - \Delta P_1 = (1 - s_1)P_1$. Similarly, output produced by the 7th order harmonic component is $(1 - s_7)P_7$. Since all the energy transferred through the air gap by the 5th order harmonic goes to losses, it does not contribute to output power. The total output power produced by the machine is given by

$$P_{out} = (1 - s_1)P_1 + (1 - s_7)P_7. \quad (4.67)$$

The efficiency of the machine can be calculated as:

$$\eta = \frac{P_{out}}{P_{in}} = \frac{(1 - s_1)P_1 + (1 - s_7)P_7}{P_1 + P_5 + P_7} \quad (4.68)$$

Since the slip s_7 is in the range of .8, maximum portion of power produced by the 7th order harmonic goes to losses and only a small part of the power actually contributes to useful energy.

In addition to that, all of the power produced by 5th order harmonic goes to losses. Therefore, if the supply voltage is distorted, it reduces the efficiency of induction machines.

Substituting the expressions for input and output powers in in Eqn. (4.68) and simplifying yields,

$$\eta = \frac{\frac{3 R_r V_1^2(1 - s_1)}{s_1 \left\{ \left(\frac{R_r}{s_1} \right)^2 + (X_r)^2 \right\}} + \frac{3 R_r V_7^2(1 - s_7)}{s_7 \left\{ \left(\frac{R_r}{s_7} \right)^2 + (7X_r)^2 \right\}}}{\frac{3 R_r V_1^2}{s_1 \left\{ \left(\frac{R_r}{s_1} \right)^2 + (X_r)^2 \right\}} + \frac{3 R_r V_5^2}{s_5 \left\{ \left(\frac{R_r}{s_5} \right)^2 + (5X_r)^2 \right\}} + \frac{3 R_r V_7^2}{s_7 \left\{ \left(\frac{R_r}{s_7} \right)^2 + (7X_r)^2 \right\}}} \quad (4.69)$$

Eqn. (4.69) gives the efficiency of an induction machine when supplied with a voltage containing 5th and 7th order harmonics in addition to the fundamental component. The results of simulation showing the effects of distortion on efficiency are presented in the fifth chapter.

4.7.5 Life expectancy and de-rating of machines

The impacts of increased losses on life expectancy and de rating of induction machines was presented in the previous chapter. Both the supply voltage asymmetry and distortion increase the losses and lead to temperature rise in the machines. In this regard, both have similar impact on induction machine. Since machines are designed to work under a certain temperature range, increment of temperature causes damage to insulation and eventually causes failure. Higher rating insulation has to be used to withstand the extra temperature rise. The size of machines also needs to be increased to produce the required output power under reduced efficiency. Thus machines have to be de rated to avoid the risk of untimely failures.

CHAPTER 5: COMPUTER MODELLING AND RESULTS

5.1 Introduction

It was discussed in the previous chapters how asymmetry and distortion in the supply voltage affects the operation of induction machines. The equations that relate its performance to supply voltage asymmetry and distortion were also developed. The essence of any theory is to provide the fundamentals of the pertaining subject matter. In many cases, it is difficult to solve equations analytically. Computer simulation can be used to solve those equations and to verify the predictions made in theory. This chapter presents the results obtained from simulation of induction machine model with MATLAB.

The analysis presented in the previous chapters was done assuming that the losses in the stator circuit were negligible. For analytical purposes it is reasonable to do so as this reduces the complexity of equations. However, simulation can be applied to the complete model of the machine since the computer can handle complex equations. Thus, the complete model of induction machine is used for simulation. The results thus obtained are more accurate.

First part of this chapter presents the verification of a model of induction machine written in MATLAB. Results are compared with examples presented in Ref. [15]. The response of the verified model for asymmetrical and distorted supply voltages are presented in the second and the third part of this chapter respectively. Simulation is done at various levels of asymmetry and distortion for a single design class of machine.

The simulations were carried out without considering the skin effects. The change in the rotor resistance with frequency is dependent on various factors like machine size, geometry and specifications. It is very difficult to generalize it.

5.2 Modeling of induction machine under sinusoidal symmetrical supply voltage

A MATLAB m-file code was written for the simulation of a 3 phase 6 pole 60 Hz 7.5 KW Y connected 208 Volts (L-L) induction machine with the parameter values as given below in Ω / phase referred to the stator side:

$$R_s = .294, R_r = .144, X_s = .503, X_r = .209, X_m = 13.25$$

The machine used in this example belongs to CLASS B as per the NEMA MG-1 Standard for machines and generators design parameters. Appendix 1 presents the characteristics of induction machine of various classes. The given model was selected because it is the most commonly used machine for general purpose applications.

The torque slip plot of the machine is given in Figure 5.1.

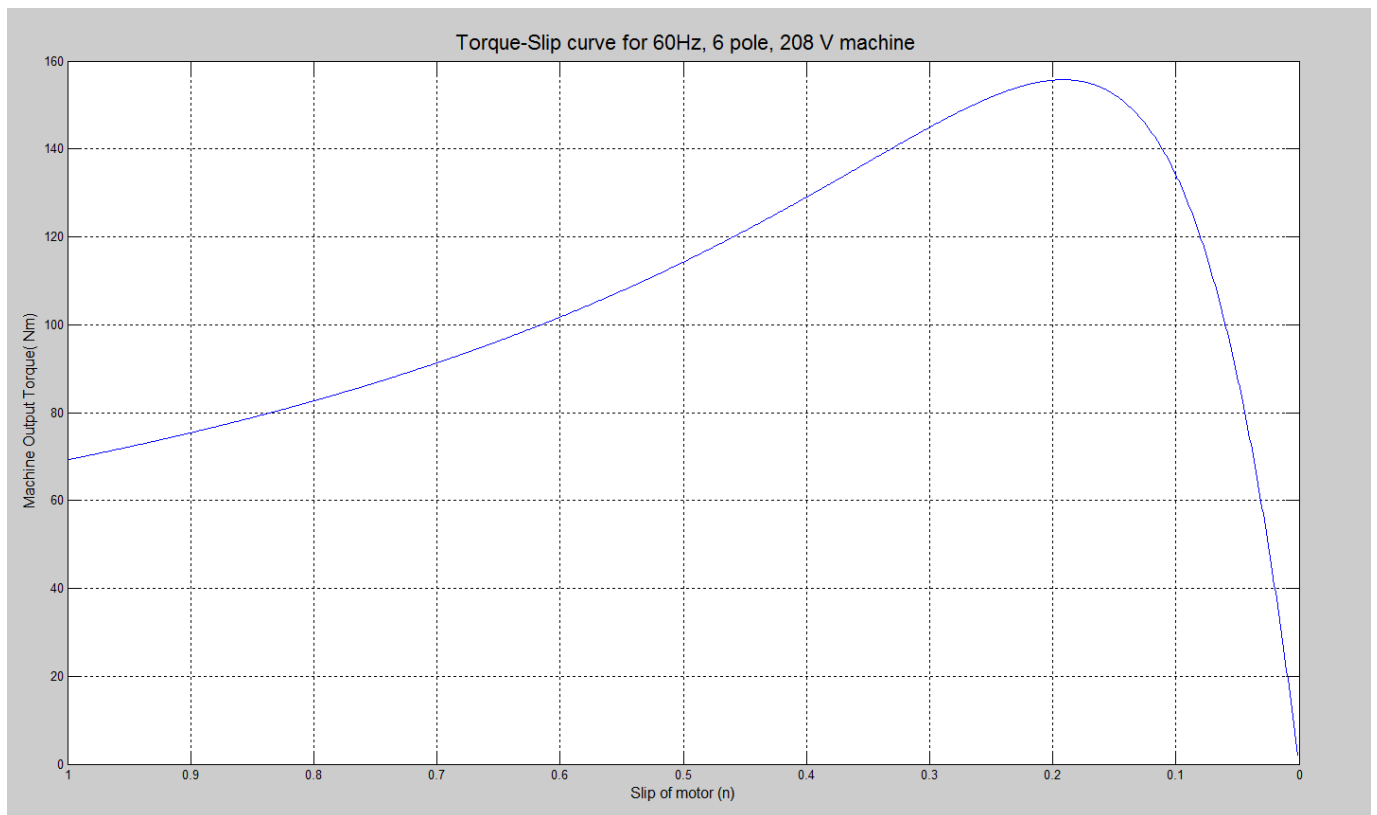

Figure 5.1: Torque-Slip plot of induction machine at symmetrical sinusoidal voltage

The starting torque produced by the machine is 69.3 Nm and the maximum torque is 155 Nm. When a load of 62 Nm is connected to the machine, it operates at a slip of .03 with 89% efficiency. The synchronous speed in RPM is 1200. The results obtained from simulation were verified by comparing to Example 6.2 in Ref [15].

5.3 Modeling of induction machine under asymmetrical sinusoidal supply voltage

The model of the machine given in section 5.2 above was tested with asymmetrical supply voltages. The results of simulations are presented in this section. The machine was supplied with voltage source with VUF ranging from 0 to 10 percent in steps of 1%. Phase A of supply voltage was set to 120 volts at 0 degrees and the remaining two phases were adjusted to get the required VUF.

5.3.1 Output torque

The torque-speed (T-S) characteristic of the machine was plotted for various levels of VUF in the supply voltage. The family of curves as shown in Figure 5.2 was obtained.

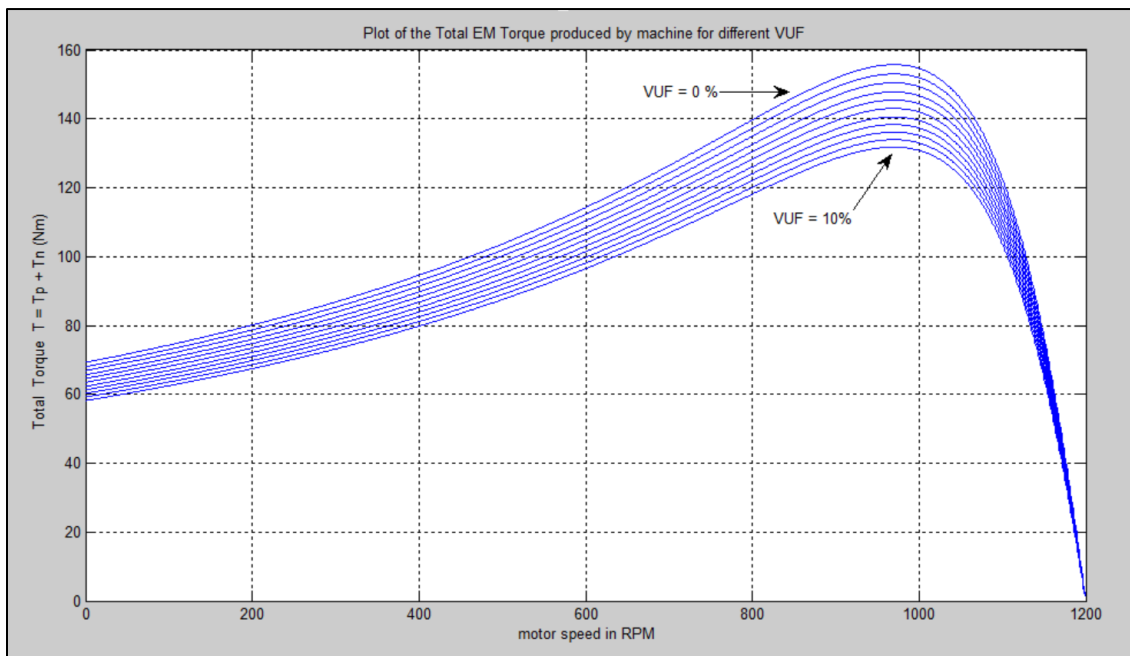

Figure 5.2: T-S plot of induction machine at varying levels of VUF

Figure 5.2 illustrates that the maximum torque and starting torque are reduced as the level of asymmetry increases. Fig. 5.3 shows the starting torques produced by the machine at various levels of VUF in detail.

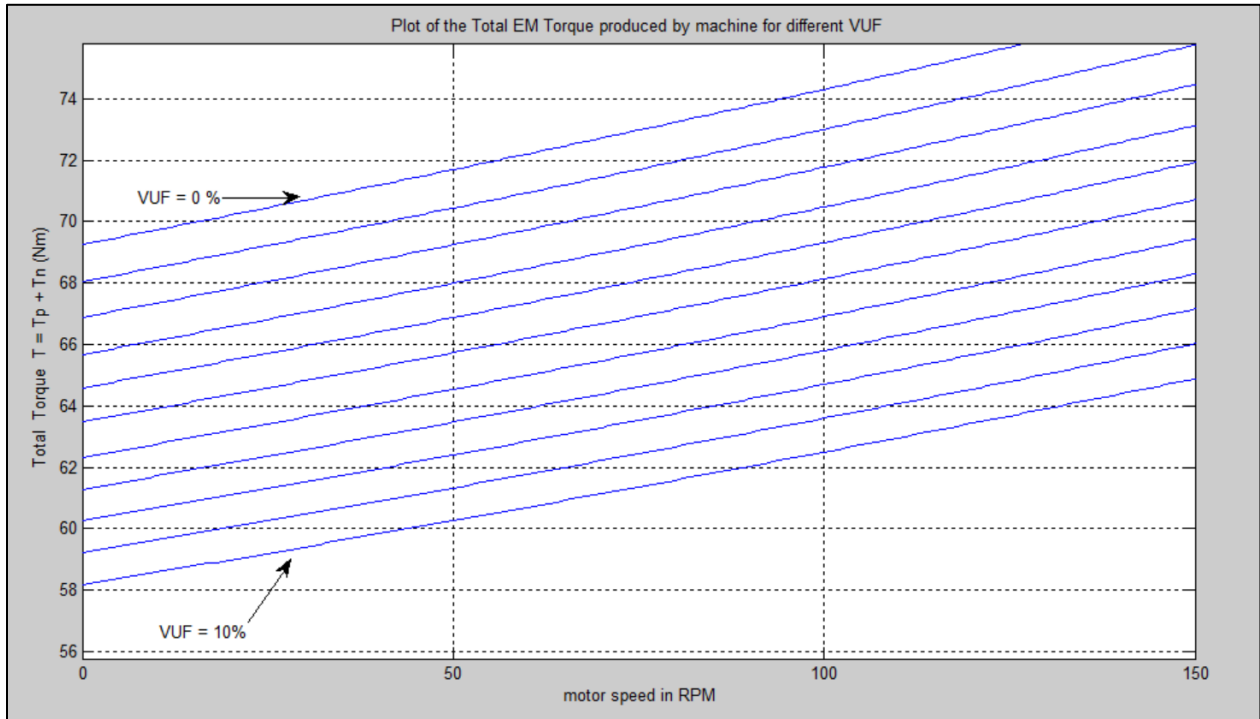

Figure 5.3: Starting torque at varying VUF

Table 5.1 : Starting and maximum torque at varying VUF

VUF (%)		0	1	2	3	4	5	6	7	8	9	10
Starting Torque	Starting Torque(Nm)	69.2	68	66.9	65.7	64.6	63.5	62.3	61.3	60.2	59.5	58.2
	Torque reduction (%)	N/A	1.734	3.324	5.058	6.647	8.237	9.971	11.4	13	14	15.9
Maximum Torque	Maximum Torque(Nm)	155.5	153	150.5	147.8	145.4	143	140.5	138	136	134	131.8
	Torque reduction (%)	N/A	1.608	3.215	4.952	6.495	8.039	9.646	11.1	12.5	13.8	15.24

Starting torque produced by the machine at symmetrical supply or 0 % VUF is 69.2 Nm and the maximum torque is 155.5 Nm. As the level of asymmetry in the supply voltage (VUF) increases, both starting and maximum torque produced by the machine are decreased. For every 1%

increase in VUF there is about a 1.7 % decrease in the starting torque and about 1.6% reduction in the maximum torque.

The shaded area in Table 5.1 shows the values of starting torque and maximum torques for a 3 % asymmetry in supply. VUF of 3 % in supply is acceptable according to NEMA guidelines. Results suggest that both the starting and maximum torque are reduced by approximately 5% at 3% asymmetry. If the machine is such designed that it is operating in its optimal rating, then a reduction of 5% can in some cases be critical to whether or not the machine can meet the demands of the connected load. The machine may not be able to overcome the starting torque of the load in which case it will fail to start, leading to excess heating of the machine.

5.3.2 Performance of machine when connected to a load of constant torque

In this section the performance of the machine is analyzed when connected to a load of 62 Nm. The load torque was kept constant at this value and VUF in the supply voltage was varied. The results of simulation are presented below.

5.3.2.1 Speed

Table 5.2 shows the speed of operation of the given machine when connected to a load of 62Nm at varying VUF in the supply voltage.

Table 5.2: Operating speed and slips at varying VUF

VUF (%)	0	1	2	3	4	5	6	7	8	9	10
Operating Speed (RPM)	1160	1160	1159	1158	1157	1156	1155	1154	1153	1152	1151
Positive seq Slip	0.033	0.033	0.034	0.035	0.036	0.037	0.038	0.038	0.039	0.040	0.041
negative seq slip	1.967	1.967	1.966	1.965	1.964	1.963	1.963	1.962	1.961	1.960	1.959

The operating speed of machine is reduced when the VUF in the supply is increased. The positive and negative sequence slips are also given in table --. As the speed reduces, the positive sequence slip increases. When the supply voltage are symmetrical the machine operates at a positive sequence slip of .033 while when the VUF is 10 %, the slip is .041, with an operating speed of 1151 RPM. Since the losses and efficiency of machine are directly related to the slip, results indicate that the losses of the machine will be increased while the efficiency will be decreased with increase in asymmetry. The operating speed and slips for VUF of 3% are highlighted. At 3% asymmetry, the speed reduces by 2 RPMs and the slip is increases by .002.

5.3.2.2 Losses

The operating speed of the machine directly correlates to losses. An induction machine consists of various components each of which can contribute to losses. Losses occurring in each of the different components of the machine are presented separately.

The detail of losses is presented in Table 5.3. The last column of the table shows the total losses. The total losses in the machine are increased with increase in VUF.

Table 5.3: Losses occurring in the machine at varying VUF

VUF (%)	Speed (RPM)	Ohmic losses in stator winding (W)			Ohmic losses in rotor winding (W)			Total loss for pos seq(W)	Total loss for neg seq(W)	Total Losses (W)
		Due to pos seq	Due to neg seq	Total	Due to pos seq	Due to neg seq	Total			
0	1160	621.4	0.0	621.4	267.4	0.0	267.4	888.8	0.0	888.8
1	1160	610.6	2.0	612.6	262.8	1.0	263.7	873.3	3.0	876.3
2	1159	625.4	7.8	633.2	270.4	3.7	274.0	895.8	11.5	907.2
3	1158	639.4	17.8	657.2	277.6	8.4	286.0	917.0	26.2	943.2
4	1157	654.3	30.2	684.5	285.2	14.3	299.5	939.5	44.5	984.0
5	1156	668.8	46.2	715.0	292.6	21.9	314.5	961.3	68.2	1029.5
6	1155	682.4	66.5	749.0	299.6	31.6	331.1	982.0	98.1	1080.1
7	1154	696.9	88.0	784.9	306.9	41.8	348.7	1003.9	129.8	1133.6
8	1153	711.2	112.5	823.6	314.2	53.4	367.5	1025.3	165.8	1191.2
9	1152	725.1	139.9	865.0	321.2	66.4	387.6	1046.3	206.3	1252.6
10	1151	738.7	170.3	909.1	328.2	80.9	409.0	1066.9	251.2	1318.1

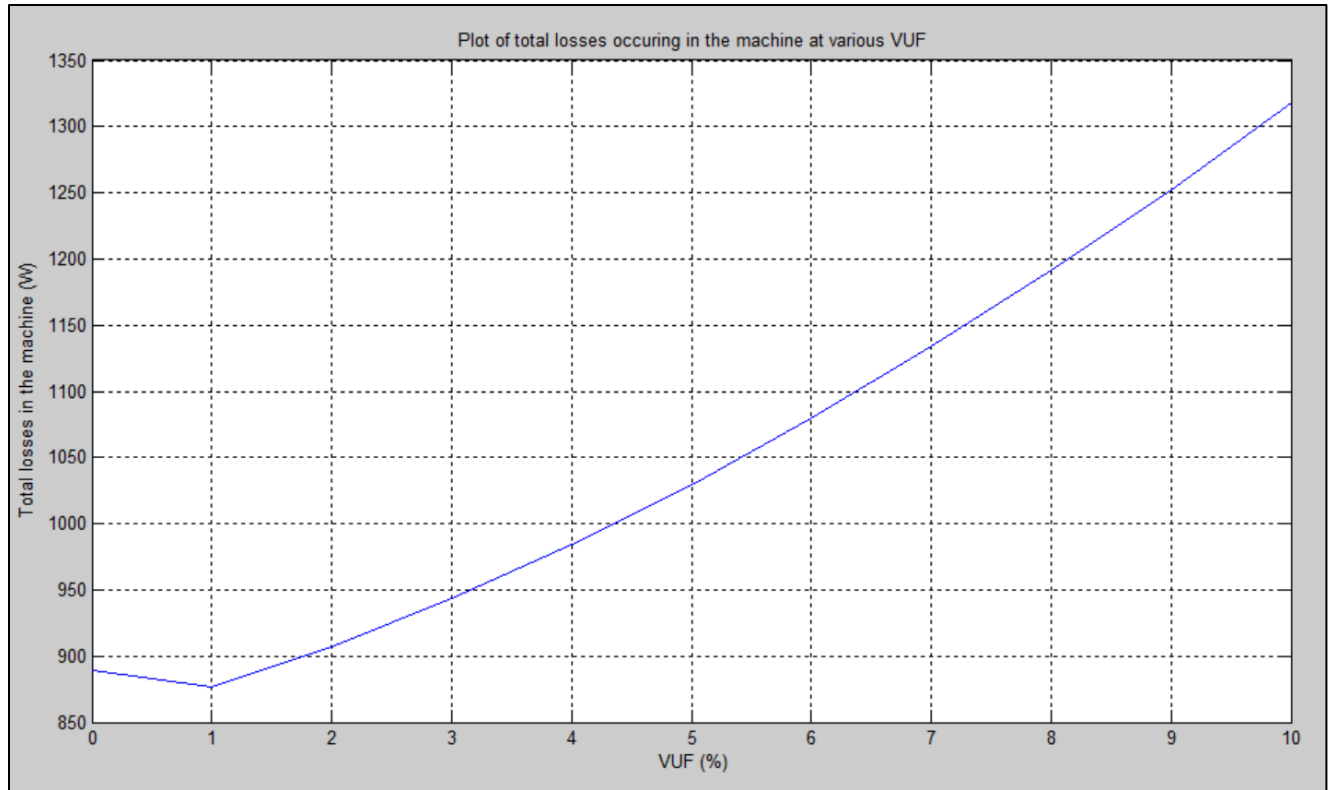

Figure 5.4: Plot of the total losses at varying VUF

The total losses occurring in the machine are plotted at varying VUF level in Figure 5.4. When the supply voltages are symmetrical, the total losses occurring in the machine are around 889 watts. When the VUF is 10%, the total losses are 1.32 kW. It is also to be noted how the slope of the figure is increasing with VUF. This suggests that the losses are actually multiplied with increase in asymmetry.

Table 5.4 : Increment in losses at varying VUF

VUF (%)	0	1	2	3	4	5	6	7	8	9	10
Total losses(W)	888.6	876.3	907.2	943.2	984.0	1029.5	1080.1	1133.6	1191.2	1252.6	1318.1
Increment in total losses (%)	N/A	-1.4	2.1	6.1	10.7	15.9	21.6	27.6	34.1	41.0	48.3

The increment in the total losses occurring due to increased asymmetry is presented in Table 5.4. When the asymmetry is 3%, the losses are increased by 6%. This is very alarming because it means that the machine will have to handle the extra 6% losses all the time. This will eventually cause the machine to fail. When the asymmetry is 10%, there is 48% increment in the losses. For asymmetry of 1%, there is reduction in losses. For the given machine at the given load, the speed of machine remains the same at 1% VUF, while the positive sequence input voltages are reduced. This means that the same output power is produced at a lower input power. Since the slip is constant, lower input power leads to reduced losses. This is a very particular case and it doesn't represent the general response of machine for 1% asymmetry. Overall, there is a big increment in the losses when the supply voltages are asymmetrical.

Table 5.5 shows that there is an increment in the losses occurring due to the positive sequence component as asymmetry increases. This is so because when the negative sequence power increases, it increases the negative sequence torque. To overcome this torque, more positive sequence current has to flow in the circuit, leading to increased losses.

Table 5.5: Losses due to the positive sequence at varying VUF

VUF (%)	0	1	2	3	4	5	6	7	8	9	10
Losses due to pos seq(W)	888.8	873.3	895.8	917	939.5	961.3	982	1004	1025.3	1046	1067
Increment in pos. seq losses (%)	N/A	-1.743	0.783	3.174	5.708	8.159	10.48	12.95	15.358	17.72	20.04

Table 5.3 also shows the losses occurring in the rotor and the stator circuits. As the level of asymmetry increases, the ohmic losses occurring in the stator circuit are much more than those in the rotor circuits. Results also suggest that most of the losses due to the negative sequence component occur in the stator of the machine. When the supply voltage is symmetrical, the stator

losses are 620 watts while at a VUF of 10%, the stator losses are 909 watts. About 170 watts is due to the negative sequence while about 740 watts are due to the positive sequence.

Results suggest that losses are increased with asymmetry in the supply voltage. Since the losses are dissipated as heat machine is subjected to excess heat when the supply is asymmetrical. The results also suggest the ohmic losses occurring in the stator winding of the machine are also highly increased. There is increased heat dissipation in the stator which can lead to thermal failure of the machine.

5.3.2.3 Efficiency and power relations

Increased level of asymmetry leads to increased losses. This will lead to a reduction in the efficiency of the machine. Table 5.6 shows the values of efficiency at various VUF levels while Figure 5.5 shows the plot of efficiency as a function of VUF.

Table 5.6: Efficiency at varying VUF

VUF (%)	0	1	2	3	4	5	6	7	8	9	10
Efficiency(%)	89.7	89.7	89.4	89.0	88.6	88.2	87.7	87.1	86.6	86.0	85.3

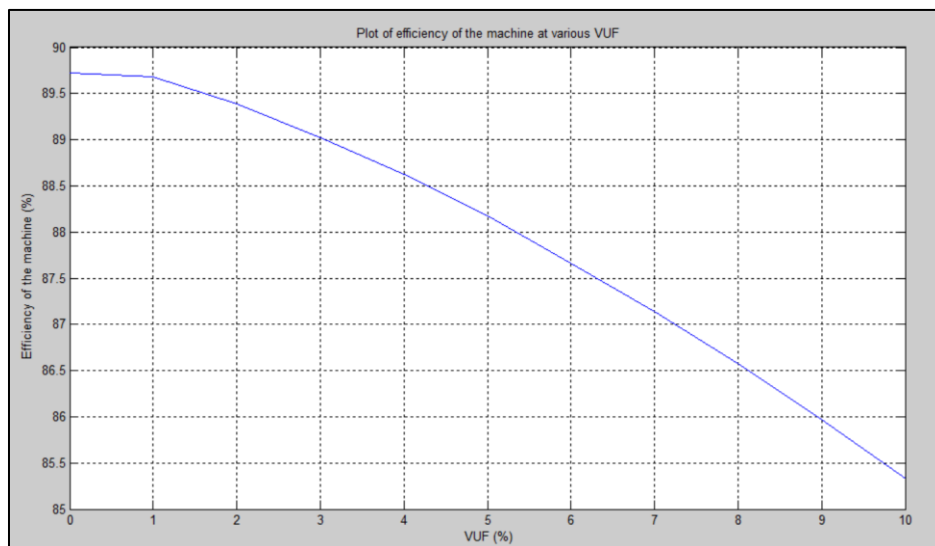

Figure 5.5: Plot of efficiency of machine at varying VUF

Table 5.6 shows how the efficiency is reduced with increase in asymmetry. When the supply voltages are symmetrical the efficiency is 89.7 % while it reduces to 85.3 % when the VUF is 10%. At 3% asymmetry, the efficiency is reduced to 89% which is only a reduction of .7 percent and therefore is not so alarming. Figure 5.5 shows the plot of efficiency at varying VUF. The efficiency reduces approximately linearly with VUF.

Although the losses are highly increased with asymmetry, there is approximately a linear relation between efficiency and asymmetry. This is because the input power of the machine increases with increased VUF and prevents the efficiency from decreasing rapidly. The relationship of various powers in the machine is presented in Table 5.7.

Table 5.7: Machine power relations at varying VUF

VUF (%)	Pos seq input power (W)	Stator power loss for pos	Pos seq air gap power (W)	Neg seq input power (W)	Stator power loss for neg seq(W)	Neg seq air gap power (W)	Output Power (W)
0	8643.7	621.36	8022.3	0.0	0	0.0	7754.9
1	8493.3	610.55	7882.8	2.5	2.0383	0.5	7619.5
2	8538.5	625.39	7913.1	9.6	7.7695	1.9	7640.9
3	8570.6	639.42	7931.2	22.1	17.766	4.3	7649.5
4	8613.2	654.34	7958.8	37.5	30.173	7.3	7666.6
5	8647.5	668.76	7978.7	57.4	46.215	11.2	7675.4
6	8670.7	682.42	7988.3	82.6	66.546	16.1	7673.2
7	8703.8	696.94	8006.8	109.3	88.004	21.3	7679.4
8	8732.1	711.17	8020.9	139.7	112.45	27.2	7680.6
9	8755.8	725.11	8030.7	173.8	139.9	33.9	7677.0
10	8775.1	738.74	8036.3	211.6	170.33	41.3	7668.6

Table shows how the output power is decreasing with increased VUF. This is because of the reduced speed. However the positive sequence input power increases with VUF. The positive sequence air gap is almost constant. This means most of the excess positive sequence power drawn from the system dissipates in the stator. Table also shows how most of the negative sequence input power dissipates as ohmic losses in the stator circuit and only a small portion of

the power crosses the air gap. When there is increased asymmetry, negative sequence components produce torque in the negative direction. Since the machine has to meet the load requirements, this means that the positive sequence has to produce extra torque. This can either be achieved through increased voltage or reduced speed. The voltage cannot be increased thus the speed is reduced. As the speed of the machine is reduced, the losses increases and more power is lost in the circuit. To fulfill the deficit of power, the machine tries to compensate by drawing more power from the system which can only be achieved through increased currents. This further increases the losses. Equilibrium is attained when the excess positive sequence power crossing the air gap balances the negative sequence air gap power. However, to attain this extra positive power, the positive sequence current is increased by a great amount which causes a lot of drop in the stator circuit.

Table 5.8: Power relations in the air gap at varying VUF

VUF	Pos seq air gap power (P_g) (W)	Neg seq air gap power (W)	Pos seq mech pow ($P_{m1} = (1-s)P_g$) (W)	Neg seq mech pow ($P_{m2} = (1-s)P_g$) (W)	Total mechanical power (W) ($P_{m1}+P_{m2}$)	Shaft Power calculated from output torque(W)
0	8022.3	0.0	7754.9	0.0	7754.9	7754.9
1	7882.8	0.5	7620.0	-0.5	7619.5	7619.5
2	7913.1	1.9	7642.7	-1.8	7640.9	7640.9
3	7931.2	4.3	7653.6	-4.1	7649.5	7649.5
4	7958.8	7.3	7673.6	-7.0	7666.6	7666.6
5	7978.7	11.2	7686.2	-10.8	7675.4	7675.4
6	7988.3	16.1	7688.7	-15.5	7673.2	7673.2
7	8006.8	21.3	7699.9	-20.5	7679.4	7679.4
8	8020.9	27.2	7706.8	-26.2	7680.6	7680.6
9	8030.7	33.9	7709.5	-32.5	7677.0	7677.0
10	8036.3	41.3	7708.2	-39.6	7668.6	7668.6

Table 5.8 shows the power relations in the air gap of the induction machine when the supply voltage is asymmetrical. It shows the portions of positive and negative sequence air gap powers going into mechanical work. The part of negative sequence air gap power going to the shaft to do mechanical work is shown as negative (Column 5). The slip for the negative sequence is greater

than 1 and the term $(1-s)$ is negative. The direction of the torque produced by negative sequence mechanical power is opposite to the direction of the torque produced by positive sequence. The portion of the positive air gap power going into mechanical work in the shaft is also given in Table 5.8. The total mechanical power produced by the machine is the sum of the mechanical powers produced by the positive and negative sequences. This power almost remains constant because the machine is connected to a load of constant torque. The total shaft power can also be calculated using the output torque and motor speed and it is shown in column 7. As the asymmetry increases, there is also an increment in the losses in the rotor for both positive and negative sequence. However, this is not as alarming as the losses in the stator circuit.

5.3.2.4 Current response of induction machine

Response of the machine in terms of its output was discussed above. It is equally important to study the current response of an induction machine when subjected to voltage asymmetry. This can be achieved by studying the asymmetry in the machine current resulting from the asymmetry in the supply voltage.

Table 5.9: Currents in the stator and rotor of the machine at varying VUF

VUF(%)	Magnitude of pos seq stator current (A)	Magnitude of neg seq stator current (A)	Magnitude of pos seq rotor current (A)	Magnitude of neg seq rotor current (A)	CUF for stator (%)	CUF for rotor (%)
0	26.54	0.00	24.88	0.00	0.00	0.00
1	26.31	1.52	24.66	1.50	5.78	6.07
2	26.63	2.97	25.02	2.92	11.15	11.68
3	26.93	4.49	25.35	4.42	16.67	17.43
4	27.24	5.85	25.69	5.76	21.47	22.41
5	27.54	7.24	26.02	7.13	26.29	27.38
6	27.82	8.69	26.33	8.55	31.23	32.47
7	28.11	9.99	26.66	9.83	35.54	36.89
8	28.40	11.29	26.97	11.12	39.77	41.22
9	28.67	12.59	27.27	12.40	43.92	45.47
10	28.94	13.90	27.56	13.68	48.02	49.64

Table 5.9 shows the values of the currents in the given machine when supplying a constant load torque of 62Nm at various VUF. When the VUF increases, the positive sequence currents for both the rotor and stator are increased. Similarly the negative sequence current also increases with VUF. But the rate at which it increases is very alarming from the perspective of power quality. CUF in the table above refers to Current Unbalance Factor which is calculated in similar manner like the VUF. The values of CUF provide indication of how induction machine reacts when subjected to asymmetry. Figure 5.6 shows the relation of VUF and stator current CUF.

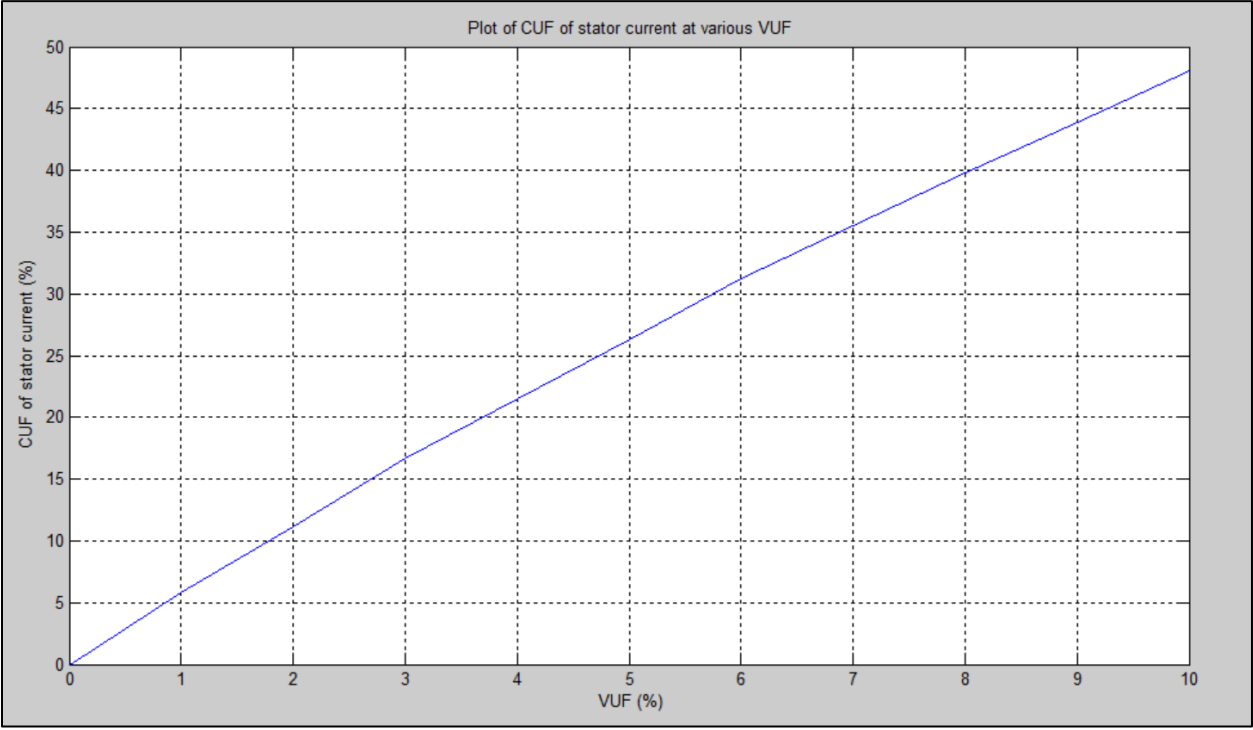

Figure 5.6: Plot of CUF in stator current at varying VUF

The asymmetry in the stator current is found to be about 5 times the asymmetry in voltages for the given set of data. What this means is that when the induction machine is supplied with asymmetrical voltages, it responds by taking highly asymmetrical currents. These currents will cause further asymmetry in voltage due to asymmetrical drops in the system impedance. The values of current for 3% VUF are highlighted in Table 5.9. This is an accepted level of voltage

asymmetry under NEMA guidelines. The asymmetry in current resulting from 3% VUF is found to be 17%. Thus there is close to 6 times increment in current asymmetry at the accepted level of voltage asymmetry. Thus an induction machine can be regarded as an amplifier of current asymmetry. Although 3% VUF may be considered benign, a CUF of 17% is very harmful to the power system in various ways.

Overall, the results obtained in this section suggest that voltage asymmetry is very harmful to the machine from the point of view of losses. Although asymmetry also affects machine torque and efficiency, the excess heat generated due to the losses is what is more critical. The machine will get damaged over time due to thermal failures if subjected to voltage asymmetry. To ensure the safety of machines, either the supply voltage asymmetry needs to be corrected or the machine size should be increased so that it can incorporate the losses. This means an addition of cost. On the other hand, induction machine acts like an amplifier of current asymmetry and is very harmful from the perspective of power quality. Since majority of the load in the power system is induction motor load; even a small amount of voltage asymmetry in the supply will lead to a high amount of current asymmetry and finally result in increased voltage asymmetry.

5.4 Modeling of induction machine under symmetrical distorted supply voltages

This section presents the results of the simulation of the same machine supplied with symmetrical distorted voltages. The THD in supply voltage was varied from 0 to 10 % in steps of 1%. The fundamental component of voltage was kept fixed at 120 V and the THD was varied by increasing the amount of harmonic content. Since the 5th and the 7th order harmonics are of opposite phase sequence, their effects on the machine were studied separately.

5.4.1 Output torque

The output torque of the machine was plotted at various levels of THD for the 5th and the 7th order harmonics. Figure 5.7 shows the torques at different THD of 7th harmonic. The subplot at the bottom shows the torque produced by the 7th order harmonic. The subplot on the top is the total torque for different THD levels. One can observe that in the subplot at the bottom, the individual curves for various THDs are distinct, while the plots for the total torque are coinciding one over another. It is so because the torque produced by the seventh harmonic component is so small that the total torque remains virtually unaffected. Since the seventh order harmonic is a positive sequence component, the greater the THD, the greater is the positive torque produced. At 10 % THD the torque produced by seventh harmonic component is approximately .004 Nm.

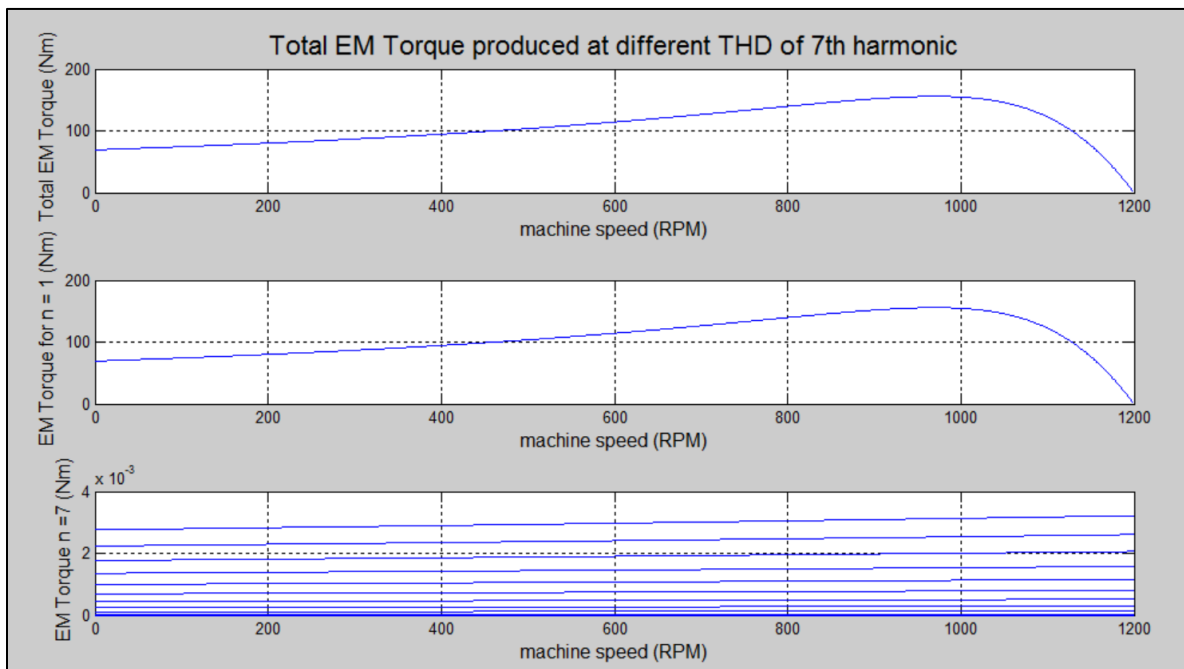

Figure 5.7: Plot of the torques produced by the fundamental and seventh harmonic component at varying THD

Figure 5.8 shows the T-S characteristics at various THD levels for the fundamental plus the seventh harmonic. The individual curves are clustered together. Figure 5.9 and gives the starting

torques for various levels of THD for the 7th order harmonic. The total variation in the overall starting torque when the THD is varied from 0 to 10 % is only about .004. Likewise, distortion of voltage doesn't have any significant impact on the maximum torque produced by the machine.

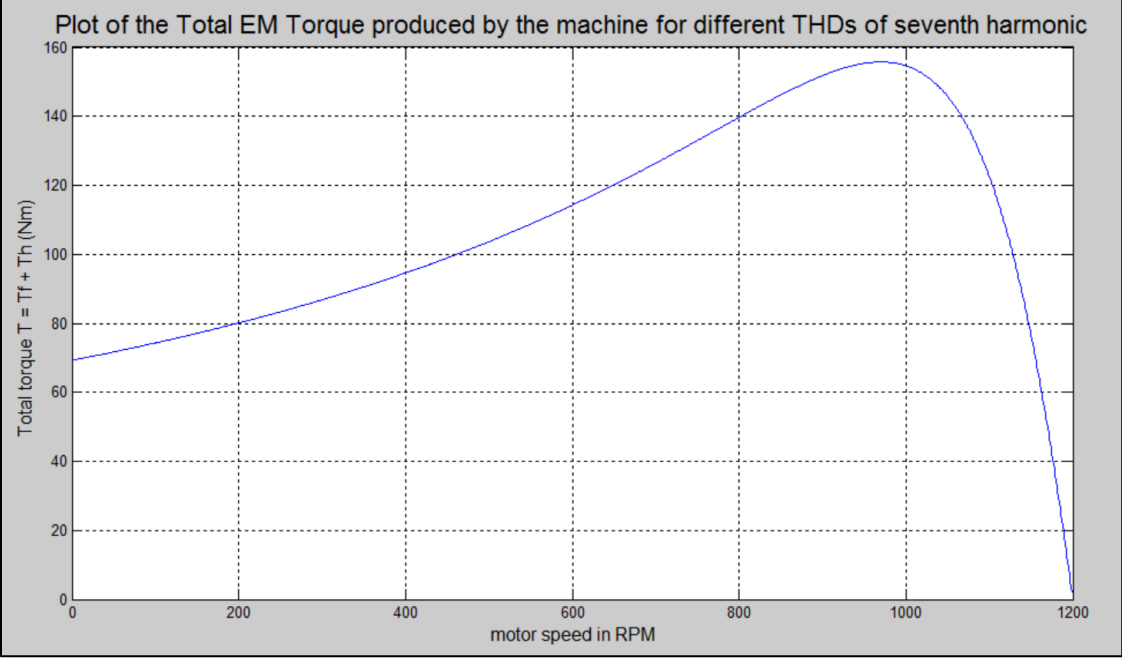

Figure 5.8: T-S plot at varying THD levels for the seventh harmonic

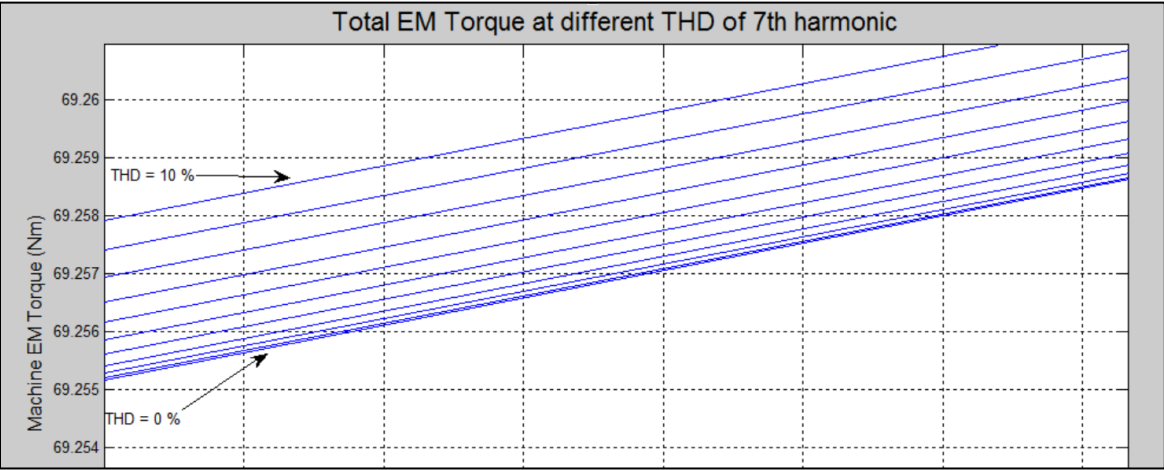

Figure 5.9: Starting torques at various THD levels for seventh harmonic

T-S plot for various THD levels corresponding to the 5th harmonic component is shown in Figure 5.10. The 5th order harmonic is negative sequence and produces torque in the opposite direction

of the fundamental component. Just like the previous case, THD in the voltage due the 5th order harmonic also doesn't have any significant impact on the torque in the machine.

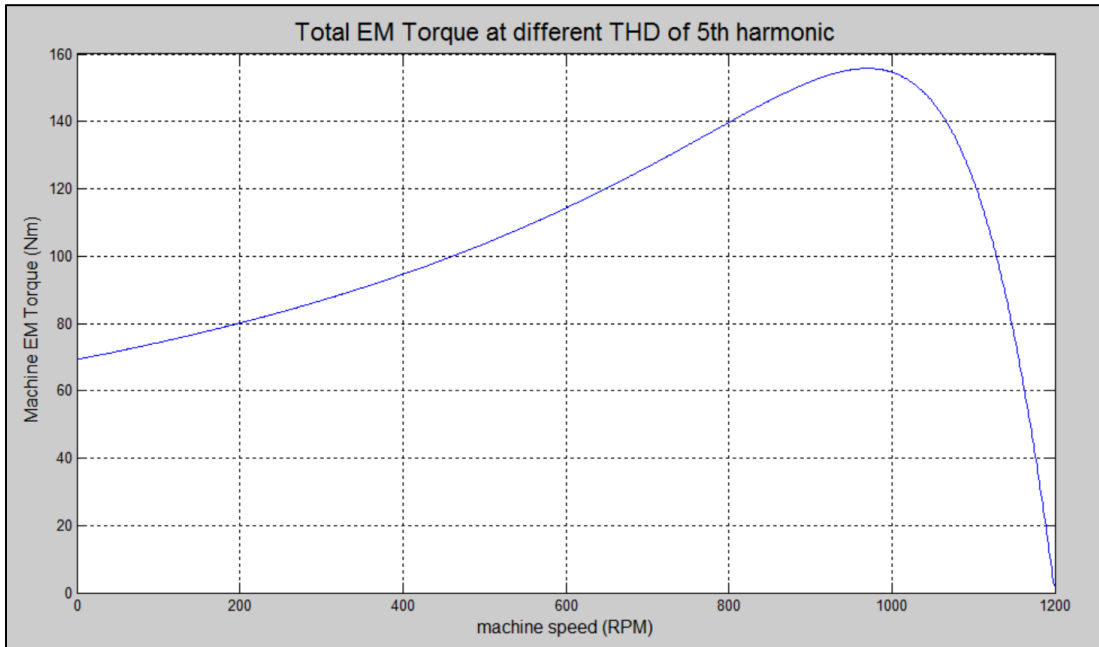

Figure 5.10: T-S plot for varying THD for fifth harmonic

The maximum and starting torques for various levels of THD is presented in Table 5.10. THD in the voltage up to 10% doesn't have any significant impact on the starting and maximum torques. Values of torques are highlighted for 3% THD. There is practically no change in the torques.

Table 5.10: Machine output torques at varying THD levels

THD(%)		0	1	2	3	4	5	6	7	8	9	10
Starting Torque (Nm)	For n = 5	69.3	69.3	69.3	69.3	69.3	69.3	69.3	69.3	69.3	69.2	69.2
	For n = 7	69.3	69.3	69.3	69.3	69.3	69.3	69.3	69.3	69.3	69.3	69.3
Maximum Torque (Nm)	For n = 5	155.8	155.8	155.8	155.8	155.8	155.8	155.8	155.8	155.8	155.8	155.8
	For n = 7	155.8	155.8	155.8	155.8	155.8	155.8	155.8	155.8	155.8	155.8	155.8

5.4.2 Performance of machine when connected to a load of constant torque

The model of the machine given in 5.2 above was simulated by supplying symmetrical voltages of various THDs while connected to a load of 62Nm torque. The load torque was kept constant at this value. The impact of distortion on machine performance is discussed below

5.4.2.1 Speed

The operating speed of the machine at various THD levels of both the 7th and 5th order harmonics is presented in Table 5.11.

Table 5.11: Machine speed and slips at varying THD levels

THD (%)		0	1	2	3	4	5	6	7	8	9	10
n = 5	Operating Speed (RPM)	1160	1160	1160	1160	1160	1160	1160	1160	1160	1160	1160
	Fund. Slip	0.03	0.03	0.03	0.03	0.03	0.03	0.03	0.03	0.03	0.03	0.03
	Harm. Slip	1.19	1.19	1.19	1.19	1.19	1.19	1.19	1.19	1.19	1.19	1.19
n = 7	Operating Speed (RPM)	1160	1160	1160	1160	1160	1160	1160	1160	1160	1160	1160
	Fund. Slip	0.03	0.03	0.03	0.03	0.03	0.03	0.03	0.03	0.03	0.03	0.03
	Harm. Slip	0.86	0.86	0.86	0.86	0.86	0.86	0.86	0.86	0.86	0.86	0.86

Table 5.11 shows how the operating speed of the machine remains unchanged for various levels of THDs for both the 5th and 7th order harmonics. This is so because the magnitude of the fundamental quantity of voltage is kept constant. The fundamental component produces the load torque required by the machine at all times and the machine doesn't slow down. This is only possible because the torques produced by the harmonic components is negligible compared to the torque produced by the fundamental component.

5.4.2.2 Machine equivalent impedance

Equivalent circuit of the induction machine for distorted supply voltages revealed how the circuit parameters are dependent on the supply voltage frequency. When the machine is supplying a

fixed load at constant speed, the impedance of the machine doesn't change. We can thus calculate the overall equivalent impedance offered by the machine.

Table 5.12: Machine equivalent impedance for different harmonics

Component	Machine equivalent impedance (ohms)
Fundamental	4.1 - 1.93i
5th harmonic	0.41 - 3.55i
7th harmonic	0.46 - 4.96i

Table 5.12 shows how the equivalent impedance offered by the machine varies with frequency. The machine operates at a slip in the range of .03 for the fundamental component, while the slip is .86 and 1.2 for the seventh and fifth harmonics respectively. Thus the equivalent rotor resistance is much higher for the fundamental component as compared to the harmonics. This consequently makes the equivalent resistance of the machine higher for the fundamental component. However, since the inductive reactance is proportional to the frequency, it increases with frequency.

5.4.2.3 Current response of induction machine

Table 5.13 presents the magnitudes of stator and rotor currents at various levels of THD for the 5th harmonic component. As explained earlier, the machine was connected to a load of constant torque of 62Nm. The magnitude of the fundamental component of voltage was kept constant at 120 V and THD was varied by varying the magnitude of the harmonic component of voltage. Consequently the fundamental component of current drawn by the machine was also found to be constant at 26.6 Amperes. This is possible because the torque produced by the harmonic components is negligible.

Table 5.13: Machine currents at varying THD levels for fifth harmonic

For n= 5						
Supply voltage THD(%)	Magnitude of fund. stator current (A)	Magnitude of harm. stator current (A)	Magnitude of fund. rotor current (A)	Magnitude of harm. rotor current (A)	THD in stator current (%)	THD in rotor current (%)
0	26.54	0.00	24.88	0.00	0.00	0.00
1	26.54	0.34	24.88	0.33	1.27	1.33
2	26.54	0.67	24.88	0.66	2.53	2.66
3	26.54	1.01	24.88	0.99	3.80	3.99
4	26.54	1.35	24.88	1.32	5.07	5.32
5	26.54	1.68	24.88	1.66	6.34	6.65
6	26.54	2.02	24.88	1.99	7.60	7.99
7	26.54	2.35	24.88	2.32	8.87	9.32
8	26.54	2.69	24.88	2.65	10.14	10.65
9	26.54	3.03	24.88	2.98	11.40	11.98
10	26.54	3.36	24.88	3.31	12.67	13.31

The magnitude of the 5th order harmonic current is very small compared to the fundamental current. The level of distortion in the currents is about 1.3 times the level of the THD in the supply voltage. This means that the induction machine doesn't amplify distortion by a great extent. Rather, it only reflects the distortion present in the supply voltages.

Table 5.14: Currents at varying THD levels for seventh harmonic

For n = 7						
Supply voltage THD(%)	Magnitude of fund. stator current (A)	Magnitude of harm. stator current (A)	Magnitude of fund. rotor current (A)	Magnitude of harm. rotor current (A)	THD in stator current (%)	THD in rotor current (%)
0	26.54	0.00	24.88	0.00	0.00	0.00
1	26.54	0.24	24.88	0.24	0.91	0.95
2	26.54	0.48	24.88	0.47	1.81	1.91
3	26.54	0.72	24.88	0.71	2.72	2.86
4	26.54	0.96	24.88	0.95	3.63	3.81
5	26.54	1.20	24.88	1.19	4.54	4.76
6	26.54	1.45	24.88	1.42	5.44	5.72
7	26.54	1.69	24.88	1.66	6.35	6.67
8	26.54	1.93	24.88	1.90	7.26	7.62
9	26.54	2.17	24.88	2.13	8.17	8.58
10	26.54	2.41	24.88	2.37	9.07	9.53

Table 5.14 shows the currents for various levels of THD of the 7th order harmonic. Comparing Table 5.14 with Table 5.13, one can observe that the magnitude of harmonic current is lower for the 7th order harmonic as compared to the 5th harmonic. This is because the impedance for the 7th harmonic component is higher than the 5th harmonic. As the order of harmonic increases, the harmonic currents will also get reduced.

5.4.2.4 Losses

The losses occurring in the machine at various levels of THD in supply voltages is presented in this section. Results due to the 5th and 7th order harmonics are presented separately.

Table 5.15: Losses in the machine at varying THD levels for fifth harmonic

For n = 5										
THD (%)	Speed (RPM)	Ohmic losses in stator winding (W)			Ohmic losses in rotor winding (W)			Total loss for fund(W)	Total loss for harm (W)	Total Losses (W)
		Due to fund.	Due to harmo.	Total	Due to fund	Due to harm.	Total			
0	1160	621.4	0.0	621.4	267.4	0.0	267.4	888.8	0.0	888.8
1	1160	621.4	0.1	621.5	267.4	0.0	267.5	888.8	0.1	888.9
2	1160	621.4	0.4	621.8	267.4	0.2	267.6	888.8	0.6	889.4
3	1160	621.4	0.9	622.3	267.4	0.4	267.8	888.8	1.3	890.1
4	1160	621.4	1.6	623.0	267.4	0.8	268.2	888.8	2.4	891.1
5	1160	621.4	2.5	623.9	267.4	1.2	268.6	888.8	3.7	892.4
6	1160	621.4	3.6	625.0	267.4	1.7	269.1	888.8	5.3	894.1
7	1160	621.4	4.9	626.2	267.4	2.3	269.7	888.8	7.2	896.0
8	1160	621.4	6.4	627.7	267.4	3.0	270.4	888.8	9.4	898.2
9	1160	621.4	8.1	629.4	267.4	3.8	271.2	888.8	11.9	900.7
10	1160	621.4	10.0	631.3	267.4	4.7	272.1	888.8	14.7	903.5

Losses due to the fundamental component are constant. Losses due to the 5th order harmonic are increasing with THD. Most of the losses for the harmonic occur in the stator circuit. At 10% THD, the losses due to the fundamental are 621 watts, while losses due to harmonic are only 10 watts. Table 5.16 shows the overall increment in the losses due to the 5th harmonic.

Table 5.16: Increment in losses for varying THD levels for fifth harmonic

THD(%)	0	1	2	3	4	5	6	7	8	9	10
Total losses(W)	888.8	888.9	889.4	890.1	891.1	892.4	894.1	896.0	898.2	900.7	903.5
Increment in total losses (%)	N/A	0.0	0.1	0.1	0.3	0.4	0.6	0.8	1.1	1.3	1.7

Table 5.17 shows the losses in the machine at various levels of THD due to the 7th order harmonic. The losses due the 7th harmonic are even lesser than the 5th harmonic.

Table 5.17: Losses in the machine at varying THD levels for seventh harmonic

For n = 7										
THD (%)	Speed (RPM)	Ohmic losses in stator winding (W)			Ohmic losses in rotor winding (W)			Total loss for fund(W)	Total loss for harm (W)	Total Losses (W)
		Due to fund.	Due to harmo.	Total	Due to fund	Due to harm.	Total			
0	1160	621.4	0.0	621.4	267.4	0.0	267.4	888.8	0.0	888.8
1	1160	621.4	0.1	621.5	267.4	0.0	267.4	888.8	0.1	888.9
2	1160	621.4	0.2	621.6	267.4	0.1	267.5	888.8	0.3	889.1
3	1160	621.4	0.4	621.8	267.4	0.2	267.6	888.8	0.6	889.4
4	1160	621.4	0.8	622.2	267.4	0.4	267.8	888.8	1.2	890.0
5	1160	621.4	1.3	622.7	267.4	0.6	268.0	888.8	1.9	890.7
6	1160	621.4	1.8	623.2	267.4	0.9	268.3	888.8	2.7	891.4
7	1160	621.4	2.5	623.9	267.4	1.2	268.6	888.8	3.7	892.5
8	1160	621.4	3.3	624.7	267.4	1.6	269.0	888.8	4.9	893.6
9	1160	621.4	4.2	625.6	267.4	2.0	269.4	888.8	6.2	894.9
10	1160	621.4	5.1	626.5	267.4	2.4	269.8	888.8	7.5	896.3

From the results of simulation, one can conclude that distortion in the supply voltage up to 10% only increases the losses in the machine by a negligible amount.

5.4.2.5 Efficiency and power relations

Efficiency of the machine at various THD levels for 5th and 7th order harmonics is given in Table 5.18. There is practically no change in the efficiency of the machine due to voltage distortion in the given range.

Table 5.18: Efficiency of the machine at varying THD level

THD (%)		0	1	2	3	4	5	6	7	8	9	10
Efficiency(%)	n=5	89.7	89.7	89.7	89.7	89.7	89.7	89.7	89.7	89.7	89.7	89.6
	n=7	89.7	89.7	89.7	89.7	89.7	89.7	89.7	89.6	89.6	89.6	89.6

Table 5.19: Power relations in the machine at varying THD levels for fifth harmonic

Voltage THD (%)	Fund. input power (W)	Stator power loss for Fund. (W)	Fund. air gap power (W)	Harm. input power (W)	Stator power loss for harm. (W)	Harm. air gap power (W)	Output Power (W)
0.0	8643.7	621.4	8022.3	0.0	0.0	0.0	7754.9
1.0	8643.7	621.4	8022.3	0.1	0.1	0.0	7754.9
2.0	8643.7	621.4	8022.3	0.6	0.4	0.2	7754.9
3.0	8643.7	621.4	8022.3	1.3	0.9	0.4	7754.9
4.0	8643.7	621.4	8022.3	2.2	1.6	0.6	7754.8
5.0	8643.7	621.4	8022.3	3.5	2.5	1.0	7754.7
6.0	8643.7	621.4	8022.3	5.0	3.6	1.4	7754.6
7.0	8643.7	621.4	8022.3	6.8	4.9	1.9	7754.5
8.0	8643.7	621.4	8022.3	8.9	6.4	2.5	7754.4
9.0	8643.7	621.4	8022.3	11.3	8.1	3.2	7754.3
10.0	8643.7	621.4	8022.3	13.9	10.0	4.0	7754.2

Table 5.19 shows the input, air gap and output power of the machine at various THD levels of 5th harmonic. The input power, power loss in the stator and the air gap power are constant for the fundamental component. The input power due to harmonic are increased with the increase in the THD but its amount is negligible compared to the fundamental. Out of the total input power for the harmonics, almost 80% is lost in the stator while only about 20% crosses the air gap. This is because the stator equivalent resistance is higher than the rotor equivalent resistance for the harmonic component. Table 5.20 shows the same relations of powers corresponding to the 7th order harmonic. The results are almost the same for the 7th order harmonic. Majority of the input power is lost in the stator and only about 20% of the total power crosses the air gap. The main difference between the two harmonic components is that in case of the 5th harmonic component, there is slight reduction in the output power. This is because the 5th harmonic component

produced torque in the opposite direction as produced by the fundamental. However since the 7th order harmonic is a positive sequence component, it produced torque in the same direction as the fundamental and therefore there is a slight increase in the total output power produced by the machine.

Table 5.20: Power relation in the machine at varying THD levels for seventh harmonic

Voltage THD (%)	Fund. input power (W)	Stator power loss for Fund. (W)	Fund. air gap power (W)	Harm. input power (W)	Stator power loss for harm. (W)	Harm. air gap power (W)	Output Power (W)
0	8643.7	621.4	8022.3	0.0	0.0	0.0	7754.9
1	8643.7	621.4	8022.3	0.1	0.1	0.0	7754.9
2	8643.7	621.4	8022.3	0.3	0.2	0.1	7754.9
3	8643.7	621.4	8022.3	0.7	0.5	0.3	7755.0
4	8643.7	621.4	8022.3	1.3	0.8	0.5	7755.0
5	8643.7	621.4	8022.3	2.0	1.3	0.7	7755.0
6	8643.7	621.4	8022.3	2.9	1.8	1.0	7755.1
7	8643.7	621.4	8022.3	3.9	2.5	1.4	7755.1
8	8643.7	621.4	8022.3	5.1	3.3	1.8	7755.2
9	8643.7	621.4	8022.3	6.4	4.1	2.3	7755.2
10	8643.7	621.4	8022.3	7.9	5.1	2.8	7755.3

Table 5.21: Power relations in the air gap at varying THD levels for fifth harmonic

For n = 5						
Voltage THD (%)	Air gap power (W)		Mech power (W) ($P_{m1} = (1-s)P_g$)		Tot Mech Power (W)	Shaft Power (W)
	Fund.	Harm.	Fund	Harm.		
0	8022.3	0.0	7754.9	0.0	7754.9	7754.9
1	8022.3	0.0	7754.9	0.0	7754.9	7754.9
2	8022.3	0.2	7754.9	0.0	7754.9	7754.9
3	8022.3	0.4	7754.9	-0.1	7754.8	7754.9
4	8022.3	0.6	7754.9	-0.1	7754.8	7754.8
5	8022.3	1.0	7754.9	-0.2	7754.7	7754.7
6	8022.3	1.4	7754.9	-0.3	7754.6	7754.6
7	8022.3	1.9	7754.9	-0.4	7754.5	7754.5
8	8022.3	2.5	7754.9	-0.5	7754.4	7754.4
9	8022.3	3.2	7754.9	-0.6	7754.3	7754.3
10	8022.3	4.0	7754.9	-0.8	7754.1	7754.2

Table 5.21 shows the power relations in the air gap of the machine at various THD levels for the 5th harmonic component. Only about 20% of the total power crossing the air gap goes to mechanical power on the shaft. Since the 5th order harmonic does work in the opposite direction, the mechanical power is negative.

Table 5.22: Power relations in the air gap at varying THD levels for seventh harmonic

For n = 7						
Voltage THD (%)	Air gap power (W)		Mech power (W) (P_{m1})= (1-s) P_g		Tot Mech Power (W)	Shaft Power (W)
	Fund.	Harm.	Fund	Harm.		
0	8022.3	0.0	7754.9	0.0	7754.9	7754.9
1	8022.3	0.0	7754.9	0.0	7754.9	7754.9
2	8022.3	0.1	7754.9	0.0	7754.9	7754.9
3	8022.3	0.3	7754.9	0.0	7754.9	7755.0
4	8022.3	0.5	7754.9	0.1	7755.0	7755.0
5	8022.3	0.7	7754.9	0.1	7755.0	7755.0
6	8022.3	1.0	7754.9	0.1	7755.0	7755.1
7	8022.3	1.4	7754.9	0.2	7755.1	7755.1
8	8022.3	1.8	7754.9	0.2	7755.1	7755.2
9	8022.3	2.3	7754.9	0.3	7755.2	7755.2
10	8022.3	2.8	7754.9	0.4	7755.3	7755.3

Table 22 shows the power relations in the air gap corresponding to the 7th order harmonic. Since the 7th harmonic component is positive sequence, there is a slight increment in the mechanical power with increased THD. One can observe that a higher portion of the air gap power goes to mechanical output for the 5th harmonic compared to the 7th harmonic. This is because the slip for the 7th harmonic is closer to 1 compared to the slip for the 5th harmonic and hence the term $(1 - s)$ is smaller. The main difference between the output powers produced by the two harmonics is that the 7th harmonic increases the mechanical output power, while the 5th harmonic reduces the mechanical output power; albeit by a negligible amount.

Compared to the negative sequence 5th harmonic component, the positive sequence 7th order harmonic seems to be less harmful to the machine. It produces positive torque and mechanical power and leads to lesser losses than the 5th order harmonic. However, it still has a negative impact to the machine overall as it increases the losses and eventually leads to a decrease in the efficiency. Therefore, both the 5th and the 7th order harmonics are harmful to the machine.

5.5 Comparison of the impacts of voltage asymmetry and voltage distortion

The effects of asymmetry and distortion were studied separately in the previous section. The results presented earlier are presented side by side in this section, so as to have a comparison of the effects of both voltage asymmetry and distortion on induction machines. Table 5.23 presents a summary of the results.

Table 5.23: Comparison of effects of voltage asymmetry and distortion

Comparison of the effects of voltage asymmetry and distortion on induction machine						
	Supply voltage asymmetry		Supply voltage distortion			
			5th Harmonic		7th Harmonic	
THD/CUF level (%)	3%	10%	3%	10%	3%	10%
Increase in slip(%)	6	24	0	0	0	0
Reduction in Torque (%)	5	15	0	0	0	0
Increment in Losses (%)	6	48	0.1	1.7	0.06	0.8
Reduction in efficiency(%)	0.8	4.9	0	0.1	0	0.1
VUF/ CUF in current (%)	17.4	49.3	3.8	12.7	2.7	9

It is clear that the impacts of voltage asymmetry are much more prominent than voltage distortion. At the accepted level of 3%, voltage asymmetry reduces torque by 5% and leads to a current asymmetry of 17.4%. At the same level of distortion, there is practically no reduction in torque and the resulting current distortion is 3.8 %. At an asymmetry of 10%, losses are

increased by 48% and asymmetry in the current is 49%. At the same level of distortion, increment in losses is negligible while the current distortion is 12%. Results suggest that voltage asymmetry is much more harmful to the machine than voltage distortion. Whereas a machine is practically unaffected by a voltage distortion in the supply of up to 10%, the same level of asymmetry can be fatal to the machine if it persists. At an asymmetry level of 3%, although the torque reduction and increment in losses are not alarming, resulting current asymmetry is in the level of 17%, which can be very harmful to the system.

5.6 Conclusion

Most of the results obtained from computer modeling were found to be in accordance to those predicted from theory. However, the losses in the stator were found to be higher than expected while the losses in the rotor circuit were lower than expected. One of the reasons for this could be the fact that the skin effect in the rotor was ignored. Since the rotor contains conductor in the form of bars, skin effect might lead to significant increase of resistance. This could also be the reason for why the effects of voltage distortion were so negligible. All the other results were as expected. The simulation was only done for a single machine at a fixed load. Results will be more reliable if the simulation is carried out for machines of different NEMA Machinery Design Categories and sizes at various levels of output load. Overall, the results reiterated the theory presented in the previous chapters of this thesis.

CHAPTER 6: CONCLUSION

Induction machines, the most common loads in the power system are designed to work under symmetrical sinusoidal voltages. When they are subjected to voltage asymmetry and distortions, their performance will change. Both voltage asymmetry and distortion have negative impacts on the machine. Asymmetry leads to an increment in losses and reductions in torque and efficiency. Voltage distortion leads to an increment in losses and a reduction in efficiency. The torque may be increased or decreased as per the order of the harmonic.

Voltage asymmetry seems to be much more harmful to the machine than voltage distortion from the perspective of machine performance as well as current response. At the accepted level of 3% asymmetry, an induction machine draws current at a level of 17% of asymmetry. In other words, it acts like an amplifier of asymmetry. Thus the regulatory body should reconsider whether or not an asymmetry level of 3% is benign when it is supplied to induction machines.

Skin effects were ignored during the analysis in this thesis. This might be the reason for why the effects of distortion on the machine were so negligible. The rotor resistance can potentially be highly increased due to skin effects leading to increased losses. To consider these effects, complete geometry of the machine is required. In that case the results will be more reliable.

REFERENCES

- [1] “ Power System Analysis”, Grainger,Stevenson
- [2] “ Electric Machine Design”, Louisiana State University, EE 4422 Reference book.
- [3] “Electric Machines”, Slemon, Straughen
- [4] “Electric Machinery”,Fitzgerald,Kingsley,Umans
- [5] “Effects of various unbalanced voltages on the operation performance of an induction motor under the same voltage unbalance factor condition”, Chin - Ying Lee
- [6] “Asymmetries in distribution systems: Causes, Harmful effects and Remedies”,Issac Plummer
- [7] “ Effects of unbalanced voltage on the operation of polyphase induction motors”, Woll.
- [8] “Heating of induction motors on Unbalanced voltage”
- [9] “Effects of unbalanced voltage on the operation performance of Three phase induction motor.” Lee
- [10] “Derating of Induction Motors Operating With a Combination of Unbalanced Voltages and Over or Undervoltages”, Pillay
- [11] “Loss of Life in Induction Machines Operating With Unbalanced Supplies”, Pillay
- [12] “Effects of voltage harmonics on the electrical and mechanical performance of Three phase induction motor”, Ching-Yin Lee.
- [13] “Polyphase Induction Motor Performance and Losses on Non Sinusoidal Voltage Sources”, Klingshirn.
- [14] “ Harmonics and Power phenomena”, Leszek Czarnecki
- [15] “ Electric Machinery”, Fitzgerald, Kingsley, Umans. Sixth edition pages(302 – 330)

**APPENDIX A: NEMA MG-1 STANDARD FOR MACHINES AND GENERATORS
DESIGN PARAMETERS**

	Class A	Class B	Class C	Class D
Type	General Purpose	General Purpose	High Starting Torque	Very High Starting Torque
Start Torque	100% rated for larger motors, 200% rated, smaller motors	100% rated for larger motors, 200% rated, smaller motors	Approx 250% rated	> 275% rated
Start Current	~800% rated	500%-600% rated		
Pullout Torque	200%-300% rated	≥200% rated	Slightly lower than class A	
Pullout Slip	<0.2	<0.2		High, can be as much as 1.0
Rated Slip	<0.05, lower than similar sized class B	must be <0.05, usually <0.03	<0.05, higher than class B	High, typically 0.07 to 0.11, can be up to 0.17
Applications	Fans, Blowers, Pumps, Machine Tools	As for Class A	Compressors, pumps, conveyors	High inertia applications, e.g. mechanical punches
Notes	High starting inrush current causes power system problems, it can cause the supply voltage to sag and requires special starting techniques. More efficient than same sized class B	Replacemesnt for Class A due to lower start current. The standard off-the shelf commodity motor.	Applications that require high start torques. Note that the pullup and pull-out torque can both be lower than the start torque. Less efficient than class B	Very high inertia applications. e.g. in a punch or reciprocal pump where the slip may vary between 0 and 0.50 Much less efficient than other designs

APPENDIX B: MATLAB CODE FOR STUDYING THE RESPONSE OF THE MACHINE UNDER SUPPLY VOLTAGE ASYMMETRY

```

% PROGRAM TO SEE THE RESPONSE OF INDUCTION MACHINE FOR ASYMMETRICAL SUPPLY
clear all;

% ELECTRICAL PARAMETERS
f = 60;
p = 6; % number of poles
pi = 22/7;
ns = 120 * f / p ; % synchronous speed rpm
omega_s = 2 * pi * ns/60 ; % synchronous angular freq
i = sqrt(-1);

% POSTIVE AND NEGATIVE SEQUENCE VOLTAGES ( from magnitude asymmetry)
VUF =[0,0.5,1,1.5,2,2.5,3,3.5,4,4.5,5];

% CORRESPONDING TO MAGNITUDE WITH 1 % INCREMENT

Vpt=[ 120-2.1316e-014i;118.95-0.60622i;117.95-1.1836i;116.9-1.7898i;115.96-2.3325i;115-2.8868i;114-
3.4641i;
113.1-3.9837i;112.2-4.5033i;111.3-5.0229i;110.4-5.5426i];
Vp = Vpt'
Vnt = [0;1.05+0.60622i;2.05+1.1836i;3.1+1.7898i;4.04+2.3325i;5+2.8868i;6+3.4641i;6.9+3.9837i;7.8+4.5033i;
8.7+5.0229i;9.6+5.5426i];
Vn=Vnt'

% MACHINE PARAMETERS g refers to given
Rsg =.294;
Rr = .144;
Xsg =.503;
Xr = .209;
Xmg = 13.25;

% USING THEVENIN THEOREM TO CALCULATE Req and Voltage
Zsth = li * Xmg * ( Rsg + li * Xsg) / ( Rsg + li * ( Xmg + Xsg));
Rsth = real(Zsth); % Dont confuse seq with sequence, this refers to stator thevenin equivalent
Xsth = imag(Zsth);

for cnt = 1:1:11

Vsth_p(cnt) = (Vp(cnt) * i * Xmg / ( Rsg + li * ( Xmg + Xsg))) ; % thevenin for positiv seq
Vsth_n(cnt)= ( Vn(cnt) * i * Xmg / ( Rsg + li * ( Xmg + Xsg))) ; % thevenin for negative seq

rpm=[0 : 1 : ns];
%Caclulation of torque and other quantities
Tem = 0;
n=0;
for n = 1 : 1 : ns+1;
sp(n)= (ns - rpm(n))/ns;
sn(n) = (-ns - rpm(n)) / (-ns);
omega_r(n) = 2 * pi * rpm(n) /60;

Irp(n) = ( Vsth_p(cnt) / ( Zsth + i*Xr + Rr/sp(n)));
Irn(n) = ( Vsth_n(cnt)/ ( Zsth + i*Xr + Rr/sn(n)));

```

```

Ztot_p = ( Rsg + 1i * Xsg) + (i*Xmg * ( i* Xr + Rr/sp(n))/ (i*Xmg + i* Xr + Rr/sp(n)));
Ztot_n = ( Rsg + 1i * Xsg) + (i*Xmg * ( i* Xr + Rr/sn(n))/ (i*Xmg + i* Xr + Rr/sn(n)));

Is_p(n) = Vp(cnt) / Ztot_p ;
Is_n(n) = Vn(cnt) / Ztot_n ;

Is(n) = Is_p(n)+Is_n(n);

Tem_p(n) = 3 * (abs(Irp(n)))^2 * Rr / ( sp(n) * omega_s);
Tem_n(n) = -3 * (abs(Irn(n)))^2 * Rr / ( sn(n) *omega_s);
Tem(n)= Tem_p(n) + Tem_n(n);
if abs(Tem(n) - Tl)< 2
    if (n > 1000)
        disp(' ')
        fprintf ('The speed at which motor runs is:%g \n',rpm(n))
        %disp(n);
        break;
    end
end
end
end

Pin_p = 3 * real( Vp(cnt) * conj(Is_p(n))) ;
Pin_n= 3 * real( Vn(cnt) * conj(Is_n(n)));
Pin_tot = Pin_p + Pin_n;

Istat_p= Is_p(n);
Irot_p = Irp(n);
Istat_n= Is_n(n);
Irot_n = Irn(n);

P_los_stat_p = 3 * (abs(Is_p(n))^2)*Rsg;
P_los_stat_n = 3 * (abs(Is_n(n))^2)*Rsg;

Pg_p = 3 * (abs(Irp(n)))^2 * Rr / sp(n);
Pg_n = 3 * (abs(Irn(n)))^2 * Rr / sn(n);

Pg_p_mech = (1 - sp(n))* Pg_p;
Pg_n_mech = ( 1 - sn(n))* Pg_n;
Pshaft = Tem(n) * omega_r(n);

P_los_rot_p= 3 * (abs(Irp(n)))^2 * Rr ;% losses in the rotor corcuits
P_los_rot_n= 3 * (abs(Irn(n)))^2 * Rr ;% losses in the rotor circuits
%
efi = 100*Pshaft / (Pin_tot) ; % considering just positive air gap power as input power to machine
P_los_tot = Pin_tot - Pshaft;
st_pos_loss(cnt)= P_los_stat_p;
st_neg_loss(cnt)=P_los_stat_n;
rot_pos_loss(cnt)= P_los_rot_p;
rot_neg_loss(cnt)=P_los_rot_n;
spd(cnt)=rpm(n);
T_em(cnt)=Tem(n);

tot_loss(cnt) = P_los_tot;
P_loss_pos_tot(cnt)=P_los_rot_p + P_los_stat_p;
efficiency(cnt)=efi;

```

```
P_pos_in(cnt)=Pin_p;  
P_neg_in(cnt)=Pin_n;  
P_pos_gap(cnt)=Pg_p;  
P_neg_gap(cnt)=Pg_n;  
P_out(cnt)=Pshaft;  
P_pos_mech(cnt)=Pg_p_mech;  
P_neg_mech(cnt)=Pg_n_mech;  
  
I_stat_p(cnt)= abs(Is_p(n));  
I_stat_n(cnt)= abs(Is_n(n));  
CUF_stat(cnt)=100 * (I_stat_n(cnt)/I_stat_p(cnt));  
  
I_r_p(cnt)= abs(Irp(n));  
I_r_n(cnt)= abs(Irn(n));  
CUF_r(cnt)=100 * (I_r_n(cnt)/I_r_p(cnt));  
  
end
```

APPENDIX C: MATLAB CODE FOR STUDYING THE RESPONSE OF THE MACHINE UNDER SUPPLY VOLTAGE DISTORTION

```
% PROGRAM TO SEE THE RESPONSE OF INDUCTION MACHINE FOR DISTORTED SUPPLY
clear all;
```

```
% ELECTRICAL PARAMETERS
```

```
f = 60;
p = 6; % number of poles
pi = 22/7;
nf = 120 * f / p ; % synchronous speed rpm
omega_s_f = 2 * pi * nf/60 ; % synchronous angular freq
i = sqrt(-1);
```

```
k = 5; % Order of harmonic
```

```
nh = - k * nf; % synchronous speed in rpm of the harmonic /.. - 5 for 5th and 7 for 7th
omega_s_h = 2 * pi * nh/60; % synh speed in radians/sec for harmonic
```

```
Vf = 120;
Vhn = [0,1.2,2.4,3.6,4.8,6.0,7.2,8.4,9.6,10.8,12];
```

```
THD = [0,1,2,3,4,5,6,7,8,9,10] ;
```

```
Tl = 62 ; % initialization of load torque
```

```
% MACHINE PARAMETERS g refers to given
```

```
Rsg = .294;
Rr = .144;
Xsg = .503;
Xr = .209;
Xmg = 13.25;
```

```
% USING THEVENIN THEOREM TO CALCULATE Req and Voltage
```

```
Zsth = 1i * Xmg * ( Rsg + 1i * Xsg) / ( Rsg + 1i * ( Xmg + Xsg));
Rsth = real(Zsth); % Dont confuse seq with sequence, this refers to stator equivalent
Xsth = imag(Zsth);
```

```
% Impedance for harmonics :
```

```
Zsth_h = 1i * k * Xmg * ( Rsg + 1i * k * Xsg) / ( Rsg + 1i * k * ( Xmg + Xsg));
Rsth_h = real(Zsth_h); % Dont confuse seq with sequence, this refers to stator equivalent
Xsth_h = imag(Zsth_h);
```

```
cnter = 0;
for cnter = 1 : 1 : 11
```

```
    Vh = Vhn(cnter);
```

```

% disp('
disp('-----')

% fprintf('Results for THD = %g \n',THD(cnter))
% fprintf(' load torque %g \n',Tl);
% fprintf(' harmonic order = %g \n', k);
%disp('Results for Vn ='),(Vn)

Vsth_f = ( Vf * i * Xmg / ( Rsg + li * ( Xmg + Xsg))); % thevenin for fundamental
Vsth_h = ( Vh * i * k * Xmg / ( Rsg + li * k * ( Xmg + Xsg))); % thevenin for harmonic

% CALCULATION OF PARAMETERS
% Caclulation of torque and other paramters
% Tem = 0;
n=0;
rpm=0:1:nf ;
for n = 1 : 1 : nf+1;
    sf(n)=( nf - rpm(n))/nf;
    sh(n) = (nh - rpm(n) )/ (nh);
    omega_r(n) = 2 * pi * rpm(n) /60;

    Ir_f(n) = ( Vsth_f / ( Zsth + i*Xr + Rr/sf(n)));
    Ir_h(n) = ( Vsth_h / ( Zsth_h + i*k*Xr + Rr/sh(n)));

    Ztot_f = ( Rsg + li * Xsg) + (i*Xmg * ( i* Xr + Rr/sf(n))/ (i*Xmg + i* Xr + Rr/sf(n)));
    Ztot_h = ( Rsg + li *k* Xsg) + (i*Xmg *k* ( i*k* Xr + Rr/sh(n))/ (i*k*Xmg + i*k* Xr +
Rr/sh(n)));

    Is_f(n) = Vf / Ztot_f ;
    Is_h(n) = Vh / Ztot_h ;

    Tem_f(n) = 3 * (abs(Ir_f(n)))^2 * Rr / ( sf(n) * omega_s_f);
    Tem_h(n) = 3 * (abs(Ir_h(n)))^2 * Rr / ( sh(n) * omega_s_h);
    Tem(n)= Tem_f(n) + Tem_h(n);
    if abs(Tem(n) - Tl)< 2
        if (n>1100)

%         fprintf ('The speed at which motor runs is:%g \n',rpm(n))
%         fprintf ('fundame slip :%g \n',sf(n))
%         fprintf ('harmonic slip:%g \n',sh(n))
        %disp(n);
        break;
    end
end
end
end
end

%CALCULATION OF DIFFERENT POWERS IN THE MACHINE

```

```

I_st_f = abs(Is_f(n));
I_st_h = abs(Is_h(n));
I_rot_f = abs(Ir_f(n));
I_rot_h = abs(Ir_h(n));

Vtf= abs(Vsth_f);
Vth=abs(Vsth_h);

Pin_f = 3 * real( Vf * conj(Is_f(n))) ;
Pin_h= 3 * real( Vh * conj(Is_h(n)));
Pin_tot = Pin_f + Pin_h;

P_los_stat_f = 3 * (abs(Is_f(n))^2)*Rsg;
P_los_stat_h = 3 * (abs(Is_h(n))^2)*Rsg;

Pg_f = 3 * (abs(Ir_f(n)))^2 * Rr / sf(n);
Pg_h = 3 * (abs(Ir_h(n)))^2 * Rr / sh(n);
Pshaft = Tem(n) * omega_r(n);

P_los_rot_f= 3 * (abs(Ir_f(n)))^2 * Rr ;% losses in the rotor corcuits
P_los_rot_h= 3 * (abs(Ir_h(n)))^2 * Rr ;% losses in the rotor circuits

efi = Pshaft / (Pin_tot) ; % considering just postive air gap power as input power to machine
P_los_tot = Pin_tot - Pshaft;

I_st_f = abs(Is_f(n));
I_st_h = abs(Is_h(n));
I_rot_f = abs(Ir_f(n));
I_rot_h = abs(Ir_h(n));

P_lo_st_f(cnter)= P_los_stat_f;
P_lo_st_h(cnter)=P_los_stat_h;
P_lo_rot_f(cnter)= P_los_rot_f;
P_lo_rot_h(cnter)=P_los_rot_h;
effic(cnter)=efi*100;

P_input_f(cnter)=Pin_f;
P_input_h(cnter)=Pin_h;
P_gap_f(cnter)=Pg_f;
P_gap_h(cnter)=Pg_h;
P_out(cnter)=Pshaft;
P_mech_f(cnter)= (1-sf(n)) * P_gap_f(cnter);
P_mech_h(cnter)= (1-sh(n)) * P_gap_h(cnter);

end

```

VITA

Prashanna Dev Bhattarai was born in Kathmandu, Nepal in April, 1984. He graduated from his high school, St. Xavier's Campus, in 2003. He attended Pulchowk Engineering Campus for the study of Bachelor of Electrical Engineering. Upon graduating in 2008, he worked for a year in Nepal before joining the Department of Electrical Engineering at Louisiana State University in 2009. He is currently pursuing his PhD in Electrical Engineering at Louisiana State University, where he is also employed as a Teaching Assistant. He worked as a Summer Intern at the Entergy Transmission and Distribution Headquarters in Jackson, MS in the summer of 2012.