

2011

# Parameter tuning and experimental results of power system stabilizer

Bixiang Tang

*Louisiana State University and Agricultural and Mechanical College*, btang1@lsu.edu

Follow this and additional works at: [https://digitalcommons.lsu.edu/gradschool\\_theses](https://digitalcommons.lsu.edu/gradschool_theses)



Part of the [Electrical and Computer Engineering Commons](#)

---

## Recommended Citation

Tang, Bixiang, "Parameter tuning and experimental results of power system stabilizer" (2011). *LSU Master's Theses*. 2315.  
[https://digitalcommons.lsu.edu/gradschool\\_theses/2315](https://digitalcommons.lsu.edu/gradschool_theses/2315)

This Thesis is brought to you for free and open access by the Graduate School at LSU Digital Commons. It has been accepted for inclusion in LSU Master's Theses by an authorized graduate school editor of LSU Digital Commons. For more information, please contact [gradetd@lsu.edu](mailto:gradetd@lsu.edu).

**PARAMETER TUNING AND EXPERIMENTAL RESULTS OF POWER SYSTEM  
STABILIZER**

**A Thesis  
Submitted to the Graduate Faculty of the  
Louisiana State University and  
Agricultural and Mechanical College  
in partial fulfillment of the  
requirements for the degree of  
Master of Science in Electrical Engineering**

**in**

**The Department of Electrical & Computer Engineering**

**by  
Bixiang Tang  
Bachelor of Electrical Engineering, Jiangsu University, 2006  
Master of Electrical Engineering, Jiangsu University, 2009  
May 2011**

*Dedicated to my parents*

# ACKNOWLEDGEMENTS

I would like to express my sincere appreciation to my advisor Dr. Gu Guoxiang for his valuable academic suggestions and patient guidance throughout the research and preparation of this thesis. His expertise and technical advice deeply influenced me and my work recorded herein. Without his valuable suggestions and constructive direction, this thesis would not have been completed.

Meanwhile, I would like to thank my co-advisor Mr. Michael L. McAnelly for providing me the opportunity to work in the power control lab of his PCS2000 Company and do many experiments for my thesis research, although I burnt out quite a few fuses. His profound experiences on power systems help me greatly in understanding the power system.

I would also like to thank Dr. Shahab Mehraeen for the papers and suggestions he gave to me during the thesis preparation that saves me a lot of time.

Thanks also go to my cherished parents who always trust and support me through the years. Without their support, I would not be able to study here and chase my dream. I deeply thank them.

Finally, I would like to thank the faculty, students in Electrical and Computer Engineering Department of LSU and the staff members at PSC2000 Company for all the help I received.

# TABLE OF CONTENTS

ACKNOWLEDGEENTS.....	iii
LIST OF TABLES.....	vi
LIST OF FIGURES.....	vii
ABSTRACT.....	ix
CHAPTER 1 INTRODUCTION.....	1
1.1 Thesis Scope and Motivations.....	1
1.2 Research Work on PSS.....	4
1.3 Thesis Contribution.....	6
1.4 Organizarion.....	7
CHAPTER 2 FEEDBACK POWER CONTROL SYSTEM.....	8
2.1 Feedback Power Control System.....	8
2.1.1 Plant.....	9
2.1.2 Automatic Voltage Regulator (AVR).....	9
2.1.3 Power System Stabilizer (PSS).....	11
2.2 Summary.....	20
CHAPTER 3 POWER CONTROL SYSTEM MODEL.....	22
3.1 Nonlinear Model.....	22
3.2 Linearized Model.....	25
3.3 Input and Output Relation.....	28
CHAPTER 4 TUNING OF PSS WITH EXPERIMENTAL RESULTS.....	31
4.1 Tuning Schemes.....	31
4.2 Real System Tuning.....	32
4.2.1 Tuning Conditions.....	32
4.2.2 Introduction to DEC400.....	34
4.2.3 Real System Tuning Scheme.....	36
4.2.4 Tuning in Real System.....	37
4.3 Final Result of PSS Tuning.....	42
CHAPTER 5 CONCLUSION.....	46
5.1 Work Complete.....	46
5.2 Work to Be Done in the Future.....	47

REFERENCES.....49

VITA.....51

# LIST OF TABLES

Table 2-1 Symbol list.....	16
Table 3-1 Symbol list.....	23
Table 3-2 Symbol list.....	25
Table 3-3 Symbol list.....	26
Table 3-4 Symbol list.....	27
Table 3-5 Symbol list.....	28
Table 4-1 PSS settings.....	42

# LIST OF FIGURES

Figure 1.1 Disturbance from heater.....	2
Figure 1.2 Disturbance from motor start.....	3
Figure 2.1 System structure.....	8
Figure 2.2 AVR structure.....	10
Figure 2.3 Rotor oscillation and way of controlling the field current.....	12
Figure 2.4 Integral-of-Accelerating Power Stabilizer PSS2A(B) model.....	16
Figure 2.5 High-pass and Low-pass filters for rotor speed input.....	18
Figure 2.6 High-pass filter and Integrator for electrical power input.....	19
Figure 2.7 Ramp-Tracking filter.....	19
Figure 2.8 Stabilizer Gain and Phase Compensator.....	20
Figure 3.1 Schematic synchronous machine [13].....	22
Figure 3.2 Type-AC8B AVR.....	27
Figure 3.3 Linearized block diagram of synchronous generator control system.....	28
Figure 4.1 Generator system structure.....	33
Figure 4.2 system load distribution.....	33
Figure 4.3 AVR structure.....	35
Figure 4.4 Simplified system diagram for tuning.....	36
Figure 4.5 Step response.....	37
Figure 4.6 Frequency response of AVR.....	38



Figure 4.7 PSS filter phase lag obtained by MATLAB.....	39
Figure 4.8 PSS filter phase lag obtained by DECS-400.....	39
Figure 4.9 Phase Compensator in MATLAB.....	40
Figure 4.10 Phase compensator in DECS-400.....	40
Figure 4.11 System begins oscillating.....	41
Figure 4.12 Generator frequency under step load change without PSS equipped when turbine mechanic power is low.....	43
Figure 4.13 Generator frequency under step load change with PSS equipped when turbine mechanic power is low.....	43
Figure 4.14 Generator frequency under step load change without PSS equipped when turbine mechanic power is increased.....	44
Figure 4.15 Generator frequency under step load change with PSS equipped when turbine mechanic power is increased.....	44

# ABSTRACT

Power system stabilizers (PSS) have been studied for many years as a method to increase power system stability. This thesis focuses on the tuning and structure of the power system stabilizer. Different types of power system stabilizers are reviewed. The one studied in this thesis is the integral of accelerated power stabilizer. The generator control system is introduced to illustrate the working environment of the PSS. The mathematic model of the generator, automatic voltage regulator and PSS are analyzed and the system transfer function in presence of the PSS is derived. Base on the transfer function, a new tuning method is introduced which does not require all the system parameters. It is an experiment based tuning method. Frequency response tests are at the core of the method. The feasibility of this tuning method is illustrated and verified for the real power system in the power control lab of the PCS2000 Company. Our experiments show that after tuning, system damping is increased and the oscillation is reduced that proves the effectiveness of our PSS tuning method.

# CHAPTER 1 INTRODUCTION

## 1.1 Thesis Scope and Motivations

The stability of power system is the core of power system security protection which is one of the most important problems researched by electrical engineers. As the permanent network extension and ongoing interconnections, the complexity of power system is increasing worldwide [9]. Hence, it becomes more easily to get failures, even the catastrophic failures. For example, in a short span of two months in 2003, there were several blackouts that happened around the world and affected a number of customers; On August 14, 2003, in Northeast United States and Canada, the blackouts affected approximately 50 million people; it took over a day to restore power to New York City and other affected areas. It is considered as one of the worst blackouts in the history of these countries; On August 28, 2003, in London, the blackouts affected commutes during the rush hour and caused an approximately 50-minute loss of power supply to about 20% of the London demand (734MW); On September 23, 2003, in Sweden and Denmark, the blackout affected approximately 5 million people. The power supply was restored after 5 hours to most of the customers; On September 28, 2003, in Italy, the blackout affected about 57 million people. The power restored to major cities after 5-9 hours. It was considered the worst blackout in Europe. Although the blackouts are still the small probability events, they always cause huge expense to power utilities and customers [1, 2, 3]. The reasons of blackouts are very complex. There are still many questions waiting to be answered. However, there are some reasons enhancing the occurrence of blackouts. One is the increased complexity of the

power systems. It increased the difficulty of system-wide coordination of back up protection and also causes more disturbances; another reason is the fast increasing power supply demand exceeds the increase in power plant construction. It causes the generators overload and become more sensitive to the disturbance, which cause the generator protection relays to more frequently trip off the generators and cause more generators overload. Then, the chain of unwanted events may occur [1].

Hence, to make the power system stable, one method is to update the coordination of protection, another method is increase stability margin of each generator.

In the power system, there are many disturbances influencing the power grid and affect generator reliability. Some disturbances are from large loads. When the large loads suddenly connected to the power grid, the generator will be impacted by the suddenly increased power requirement, as the figures show below.

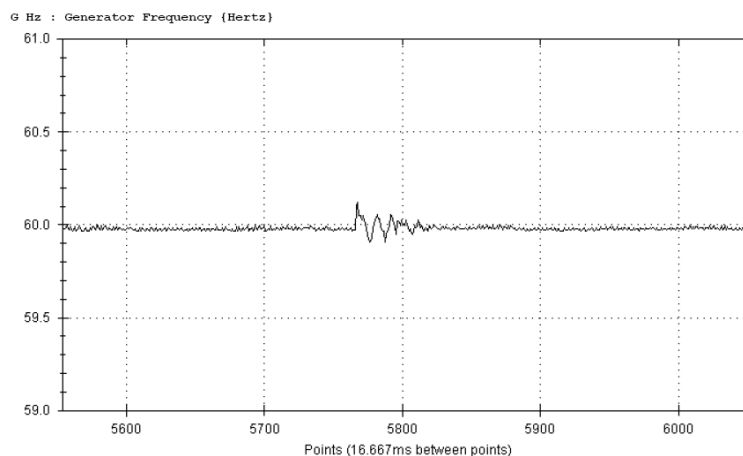

**Figure 1.1 Disturbance from heater**

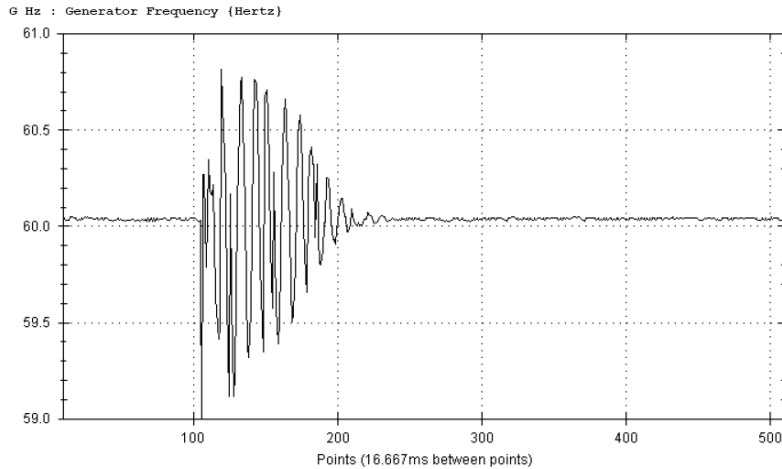

**Figure 1.2 Disturbance from motor start**

When loads are suddenly added to the power system, the frequency of generator begins oscillating. It also can be considered as the rotor angle oscillation of the generator. With the small load (Figure1.1) the oscillation can quickly be damped out while with the large load (Figure1.2), the oscillation will last for a long time before it is damped out. The worst result of the oscillation is the generator out of synchronous and tripped off by the generation protection relay. Then the loss of generator may cause more loads suddenly impact to other generators.

Some disturbances are caused by faults. When some faults occur in the power grid, the protection relays will quickly isolate the fault. But once the protection relays fail to react to the fault, it means extremely large load add to the power system. Then, it will cause generator rotor oscillates and even be tripped off from the grid by relays.

Renewable energy is also a disturbance source. As the shortage of oil and fossil fuel, renewable energy is continuously growing. And it now starts compromising the stability of electrical grids. Compare to fossil fuel power plants, energy production of wind and photovoltaic energy is fluctuating. As a result, the renewable energy fluctuation is a big challenge to power

grid stability [5]. The shortage of oil enhances the development of hybrid vehicles and electromotive vehicles. In the foreseeable future, high power battery charge stations will be established for these vehicles to replace the gas stations. Hence, the power grid will face more impaction from these battery charge stations. Thus, the generators will face more disturbances.

In some cases, due to the limitation of power transfer capability, these disturbances will exist in the grid for a long period as the small magnitude and low frequency load flow oscillation [4]. It will reduce the quality of power transmission and the stability of power system. Beginning in the late 1950's and early 1960's most of the new generators connected to electric utility systems were equipped with continuously-acting voltage regulators. Thus, the power system stabilizers are developed to aid in damping these oscillations via modulating the generator excitation. As the expansion of the power grid, the interconnection becomes more and more complex. Due to the power systems are complex non-linear system, and they are often subjected to low frequency oscillation. The requirement of power system stabilizers becomes more urgent than before. That is the reason why engineers spend much more time on researching power system stabilizers (PSS). [6, 7, 8]

Today, many generators are equipped the PSS. But, due to the complex of PSS, few people know how to tune it. Thus, correct tuning of PSS becomes very critical today. Hence, this thesis will mainly focus on the introduction of PSS and how to tune the PSS based on the real power system in the lab of PSC2000 Company.

## **1.2 Research Work on PSS**

In power system, PSS is used to add damping to generator's electromechanical oscillations. It

is achieved by modulating the generator's excitation so as to produce adequate of electrical torque in phase with rotor speed deviations. In mid-1960s when generators were equipped with continuously-acting voltage regulators, the PSS become feasible. Early PSS installations were based on various methods to obtain an input signal proportional to small speed deviations of oscillations. The earliest PSS is Speed-Based Stabilizer. It directly derives the input signal by measuring the shaft speed. It is successfully used in hydraulic units since the mid-1960s [17]. The stabilizer's input signal was obtained from a transducer which using a toothed-wheel and magnetic probe to get shaft speed signal in form of frequency and transform the frequency signal into voltage signal by a frequency-to-voltage converter. The big disadvantage of this type of PSS is the noise caused by shaft run-out and other random causes [17, 18]. Conventional filters cannot remove these low frequency noises without affecting the useful signal measured. Frequency-based stabilizer is another type of PSS. It directly uses terminal frequency as the input signal for PSS application at many locations in North America. Terminal voltage and current inputs were combined to generate a signal that approximates to the generator's rotor speed. However, the frequency signals measured at thermal units' terminals still contain torsional components. It is still necessary to filter torsional modes when the power system stabilizers are applied in steam turbine units. Hence, in the frequency- based stabilizers have the same limitations as the speed-based stabilizers [19]. Power-based stabilizer uses the electrical power as the input signal. Because of the easily measuring of electrical power and its relationship to generator shaft speed, the electrical power was considered to be a good choice as the input signal to early power system stabilizers. From the measurement of electrical power, the shaft

acceleration can be easily obtained. By using both high-pass and low pass filtering, the stabilizer can provide pure damping torque at one electromechanical frequency. However, there are two major disadvantages, one is it cannot provide damping to more than one frequency. Another one is it will produce incorrect stabilizer output whenever mechanical power changes occur [10]. Although the power-based stabilizers had so many disadvantages, in the early time they were the most efficiency stabilizers that can provide pure damping and they are still in operation today. To avoid the limitations of these stabilizers, the integral-of-Accelerating Power Stabilizer was developed. It measures the accelerating power of the generator. The major advantage of this stabilizer is it no need for a torsional filter in the main stabilizing path. And it permits a higher stabilizer gain so that it can provide better damping of the system oscillations. The conventional input signal of shaft speed or compensated frequency can be used in this type of stabilizer. Thus, the integral-of-Accelerating Power Stabilizers are rapidly being used and replacing other old type of stabilizers. And this stabilizer will be introduced in detail in the next chapter. [10, 11, 12, 13]

### **1.3 Thesis Contribution**

In this thesis, it will introduce the structure of the power system stabilizer and the mathematic model of the generator control system equipped with PSS. Based on the mathematic model, it will explain how the PSS increases the system damping. Due to the complexity of power system and the lack of system parameters in most cases, the thesis introduces a new way to tuning the PSS, which does not need to get all the parameters of the system. The experiment result shows this method is effective.



## **1.4 Organization**

There are 5 chapters in this thesis. Chapter 1 is the brief introduction of PSS application background. Chapter 2 mainly introduces the structure of the feedback power control system, and the detail of integral-of-Accelerating Power Stabilizer. Chapter 3 provides the mathematic model of synchronous generator, automatic voltage regulator and power system stabilizer. And it also explains the control scheme according to the transfer function that combines PSS AVR and generator system. Chapter 4 gives the method of tuning PSS and shows the real system tuning example. Chapter 5 is the summary of the whole thesis.

# CHAPTER 2 FEEDBACK POWER CONTROL SYSTEM

The feedback power control system is made up of the plant, automatic voltage regulator and power system stabilizer. In this chapter, the thesis is going to introduce the structure and working scheme of each part in the system. And it will mainly focus on introducing the structure, mathematic model of power system stabilizer which can increase the stability of the generator.

## 2.1 Feedback Power Control System

The following figure shows the typical feedback power control system to be investigated:

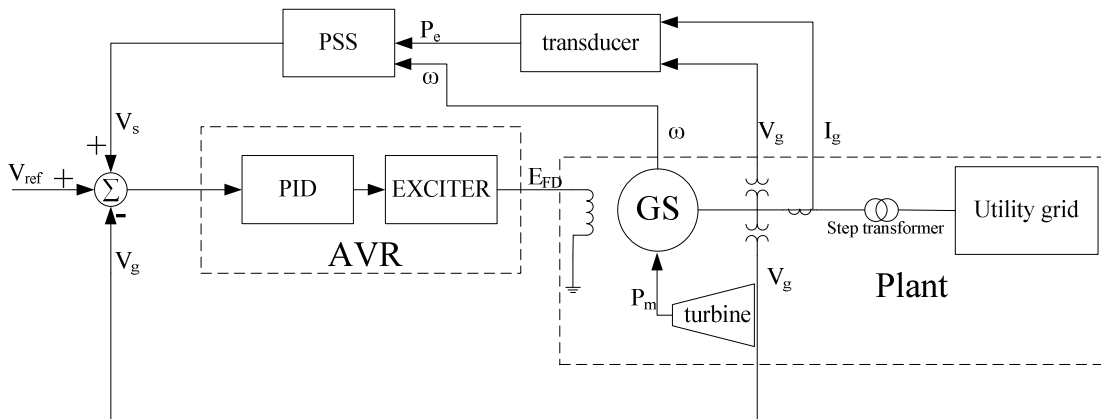

**Figure 2.1 System structure**

The power control system is designed to achieve two goals. The first is to control the generator output voltage, and the second is to increase the damping ratio to generator so as to increase the stability margin of the closed-loop system and to prevent the disturbance of the utility grid from oscillation in the generator. The overall feedback system consists of plant, the Automatic Voltage Regulator (AVR), and the Power System Stabilizer (PSS). We will discuss each of them next.

### **2.1.1 Plant**

The plant is made up of the generator and the power grid. The generator rotor is rotated by the turbine which provides the required mechanical power  $P_m$ . The control signal to the plant is the rotor field voltage  $E_{FD}$  generated by the AVR that regulates the magnetic field or  $V_g$  on the stator that is the output voltage of the generator, required for the rotor to rotate at the synchronous speed. The stator and the power grid are connected by the step transformer in order to supply power to the grid.

The plant in the diagram has one input and three outputs. The input is the control signal  $E_{FD}$  which is the AVR output. The three outputs to be controlled are voltage  $V_g$ , current  $I_g$ , and rotor rotational speed  $\omega$ . The outputs  $V_g$  and  $I_g$  are used by the transducer to deduce the electrical power  $P_e$ . The rotor speed  $\omega$  and electrical power  $P_e$  are used as the measurement signals for PSS to estimate the power change due to the possible rotor speed oscillation induced by oscillation disturbance from the power grid. If such an oscillation is present, PSS is expected to increase the damping ratio of the closed-loop system so as to damp out or reject the oscillation disturbance from the power grid.

### **2.1.2 Automatic Voltage Regulator (AVR)**

The primary function of the AVR is to control  $V_g$ , the output voltage of the generator, with the control signal  $E_{FD}$  or the rotor magnetic field. From Figure. 1, AVR consists of two parts: the PID controller and exciter. Basically the exciter serves as an actuator to generate the control signal

$E_{FD}$  by raising the output voltage of the PID controller high enough capable of regulating  $V_g$ . The block diagram of the AVR is shown below:

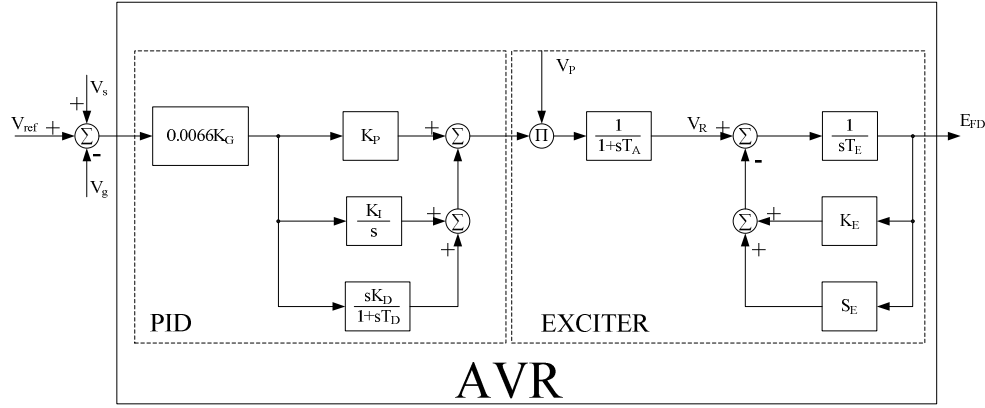

**Figure 2.2 AVR structure**

In Figure 2.2,  $V_g$  is fed back to the summing point on the left,  $V_{ref}$  is the set-point voltage or the reference voltage, and  $V_s$  is the feedback from the PSS. Recall that output  $E_{FD}$  is the voltage across the rotor winding that induces the magnetic field so as to control  $V_g$ , the output voltage of the generator.

The left dashed frame in Figure 2.2 depicts the PID controller. All the parameters can be tuned manually. The right dashed frame shows the structure of the exciter with  $V_p$  the constant power source voltage that is multiplied with the PID output voltage in order to raise the voltage  $E_{FD}$  high enough to establish the magnetic field of the rotor. However the product of the PID output and  $V_p$  has to be (lowpass) filtered in order to remove the possible noises prior to being used as the control signal. The exciter has several filtering parameters including  $T_A, T_E, K_E$ , and  $S_E$ . A typical value of  $T_A$  is 0, and all other parameters are given by the manufacturer which cannot be changed.

The signal model for AVR in Laplace domain is described by

$$E_{FD} = 0.0069K_G \cdot V_p \cdot G_{exc}(s) \cdot \left( K_P + \frac{K_I}{s} + \frac{sK_D}{1+T_D} \right) \cdot (V_{REF} + V_s - V_g) \quad (2.1)$$

in which  $V_p$  serves as an amplification gain and where

$$G_{exc}(s) = \frac{1}{sT_E + K_E + S_E} \quad (2.2)$$

is the transfer function of the exciter that depends on the structure of the exciter and can be changed in practice.

When PSS is disabled,  $V_s$  is zero. In this situation, the function of AVR regulates only the output voltage  $V_g$ . When PSS is enabled, AVR needs to help to increase the damping ratio of the close loop system.

## **2.1.3 Power System Stabilizer (PSS)**

### **1. Why PSS Is Needed?**

Many kinds of oscillation are present in power systems and they often come from the power grid and take place when a large amount of power is transmitted over the long transmission lines. Three different oscillations have been observed in large interconnected generators and transmission networks. They are Inter-unit Oscillations (1-3Hz), Local Mode Oscillations (0.7-2Hz), and Inter-area Oscillations (0.5Hz). These low frequency oscillations admit small amplitude and may last long periods of time which may cause the AVR to overreact and bring the oscillation to rotor angle of the synchronous machine that may result in serious consequences such as tripping the generator from the grid. How to attenuate the rotor angle oscillation when it exists poses a considerable challenge to feedback control of the power system. Unfortunately AVR alone is not adequate to reject the oscillation. In fact AVR can be a source of the problem to

rotor angle oscillation that will be discussed next. [6]

Sometimes rotor angle oscillation can be reduced by the damping torque. But if a sufficient damping torque does not exist, the result can be rotor angle oscillation of increasing amplitude. Once the angle change rate of the rotor or rotor speed change  $\Delta\omega$  exceeds 180 degree, the generator will lose the synchronism that will cause a well-designed protective relaying system to isolate this generator from the rest of the system causing disruption to the power system. The disturbance in the remaining system, due to the loss of generation, may result in additional units tripping off line and potentially cause a cascading outage. Therefore it is very important to increase the damping torque or damping ratio of the closed-loop system in order to reduce the rotor angle oscillation. As it is known, the rotor angle oscillation is the result of rotor speed change. Let  $I_{FD}$  be the current in rotor winding and  $\Delta I_{FD}$  be the current change of the rotor field.

The way to increase the damping torque is shown below:

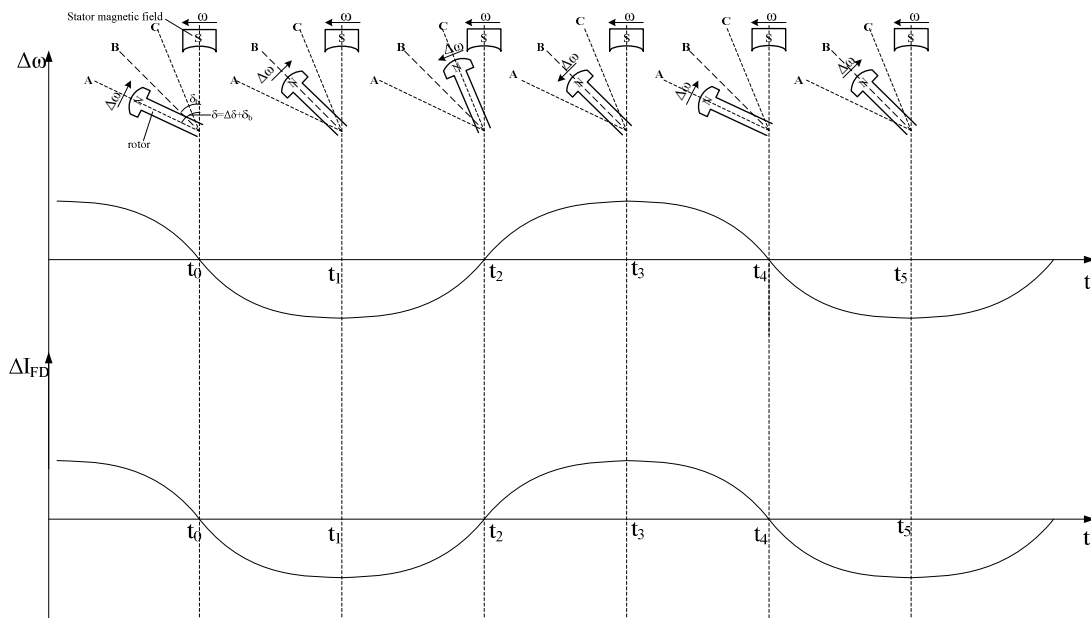

**Figure 2.3 Rotor oscillation and way of controlling the field current.**

As Figure 2.3 shows, by the synchronous motor theory, the rotor and stator magnetic field both rotate in the same direction and they follow each other. The stator magnetic field rotates at synchronous speed. In steady state the rotor also rotates at this speed. But when oscillation occurs, the rotor speed will change about this speed. Denote rotor speed change as  $\Delta\omega$ . Figure 2.3 shows the relative position between the rotor and the stator magnetic field in rotation. In the picture points A and C show the bounds of the angle changes of the rotor oscillation. When rotor arrives at point A it will return back to point C and vice versa. Point B is the middle point which implies that if there is no oscillation the rotor should be at point B. The purpose of damping torque is to reduce the oscillation bounds so that the rotor oscillation will be attenuated. When the rotor rotates moving from point A to C,  $\Delta\omega$  is negative which means that the rotor speed is reduced. So the rotor magnetic field or  $I_{FD}$  needs to be decreased as well so as to reduce the pulling force between the rotor and stator magnetic field. Also from point C to point A ( $t_2$  to  $t_4$ ),  $\Delta\omega$  is positive. So we have to increase rotor field so as to increase the pull force to pull back the rotor. And make  $\Delta\omega$  return back to zero before A point. By doing this repeatedly oscillation is then reduced or damped away. As it is known the rotor field can be changed by controlling the rotor field current  $I_{FD}$ . As discussed above, the change of  $\Delta I_{FD}$  or the rotor field need to follow the change of  $\Delta\omega$  so that the system damping ratio increases and rotor angle oscillation is attenuated. Since the feedback signal  $V_g$  does not contain information of  $\Delta\omega$ , AVR alone cannot damp out the rotor oscillation. Hence PSS is employed to produce a suitable signal  $V_s$  that is fed back to the summing point of the AVR to provide the control signal based on feedback signal of

$\Delta\omega$ . This feedback helps the rotor magnetic field to respond the change of  $\Delta\omega$  and thus to increase the damping ratio of the closed-loop system. For this reason PSS is essential without which AVR alone cannot accomplish the goal of damping out the rotor angle oscillation.

This also can be explained by the following mathematical description. By Newton's law the relationship between  $\Delta I_{FD}$  and  $\Delta\omega$  is governed by

$$\delta I_{FD} = -h \frac{d\Delta\omega}{dt}, \quad \Delta\omega = \omega_{rotor} - \omega_{syn} \quad (2.3)$$

Where  $h$  is the inertia, apply Laplace transform on both sides yields

$$\Delta I_{FD} = -h[s\Delta\Omega - \Delta\Omega(0)] \quad (2.4)$$

If  $\Delta I_{FD} = g\Delta\Omega$ , for some positive gain  $g > 0$  then

$$g\Delta\Omega = -h[s\Delta\Omega - \Delta\Omega(0)] \rightarrow \Delta\Omega = \frac{h}{(hs+g)} \Delta\Omega(0) \quad (2.5)$$

From the above expression, we conclude that  $\Delta I_{FD}$  needs to have the same phase as  $\Delta\Omega$  in order to achieve stability for  $\Delta\omega$ , which implies that the rotor field current change should have the same phase as the rotor oscillation.

Another motivation for employing PSS is due to the use of new and fast excitation systems which respond faster than old ones and are used to improve the transient response and stability. Because they have fast response, small amplitude oscillations can cause the excitation system to correct immediately. But because of the high inductance in the generator field winding, the change rate of the field current is limited that causes considerable "lag" in feedback and thus the control action. As a result there is an unavoidable time delay from recognizing a desired excitation change to its partial fulfillment. Due to the time delay that causes false phase information, oscillation is often intensified. That is, the excitation system may introduce energy



into the oscillatory cycle at the wrong time. It needs to be mentioned that most of the time the AVR has the capability of maintaining stable damping forces that restores equilibrium to the power system in presence of small oscillations. Its reason may lie in the power grid itself that does not produce “damaging oscillations”. However the power grid changes constantly and randomly and it may sometimes produce such a “damaging oscillation” that unstable oscillations can result from the negative damping force introduced by fast responding exciters. This can occur when the system is connected to the high impedance transmission power grid.

The above discussions give rise to the importance of PSS that is employed to reject the oscillation from the power grid and to prevent the rotor speed or angle from oscillation. Because both PSS and AVR are feedback controllers, it is important to emphasize that they need to be designed jointly in order to optimize the power feedback control system and to accomplish the goal of damping out the rotor angle oscillation and the goal of voltage regulation simultaneously.

## **2. Power System Stabilizer**

According to the mathematic description of  $\Delta I_{FD}$ , the signal  $\Delta\omega$  is needed to the controller in order to increase the damping ratio of the closed-loop system. If it is unavailable, it needs to be estimated based on other measurements. But by using AVR alone,  $\Delta\omega$  cannot be feedback, because  $V_g$  alone does not contain information of  $\Delta\omega$ . So the approach here is to use PSS to estimate  $\Delta\omega$  and feedback it to reduce the oscillations of the rotor angle and introduce  $V_s$  to the AVR. As a result, by using PSS and AVR together, closed-loop system damping ratio can be increased and the rotor angle oscillation can be reduced. Thus, there are two roles of PSS. One is

to estimate the  $\Delta\omega$ , and the other is to feedback  $\Delta\omega$ .

Nowadays Integral-of-Accelerating Power Stabilizer is widely used in power system stable control. The typical PSS is IEEE standard PSS2A(B) model as shown in Figure 4.

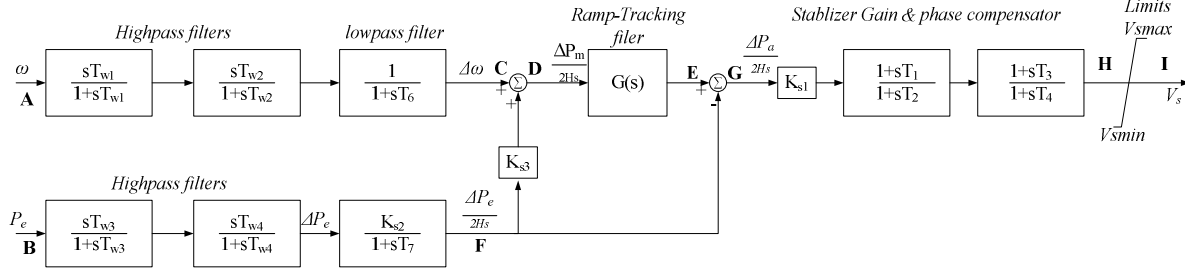

**Figure 2.4 Integral-of-Accelerating Power Stabilizer PSS2A(B) model**

This stabilizer is based on the theory that rotor rotation speed change  $\Delta\omega$  can be derived from the net accelerating power  $\Delta P_a$  acting on the rotor. In fact, the difference between the mechanical power change  $\Delta P_m$  and generated electrical power change  $\Delta P_e$  is equal to  $\Delta P_a$ . Hence, we can use the physics law to derive the mathematical relationship between  $\Delta P_a$  and  $\Delta\omega$  to ease the notation:

To avoid confusion, we list the symbols as in the following table:

Table 2-1 Symbol list

E	Rotor kinetic energy
J	Inertial
$\omega$	Rotor rotation speed
$\omega_0$	Steady state rotor rotation speed 60Hz
$\Delta\omega$	Rotor rotation speed change
$P_m$	Mechanical power
$P_{m0}$	Steady state mechanical power
$P_e$	Electrical power
$P_{e0}$	Steady state electrical power

First of all, as we know that the rotor kinetic energy equation of the rotor is :

$$E = \frac{1}{2}J\omega^2, \quad \omega = \omega_0 + \Delta\omega \quad (2.6)$$

Combining these two equations above gives:

$$E = \frac{1}{2}J(\omega_0 + \Delta\omega)^2 = \frac{1}{2}J\omega_0^2 + J\omega_0\Delta\omega + \frac{1}{2}J\Delta\omega^2 \cong \frac{1}{2}J\omega_0^2 + J\omega_0\Delta\omega \quad (2.7)$$

The term  $\Delta\omega^2$  is ignored.

On the other hand,

$$E = \int(P_m - P_e)dt \cong \frac{1}{2}J\omega_0^2 + J\omega_0\Delta\omega \quad (2.8)$$

Clearly

$$P_m = P_{m0} + \Delta P_m \quad \text{and} \quad P_e = P_{e0} + \Delta P_e$$

$$\int(P_{m0} - P_{e0})dt = \frac{1}{2}J\omega_0^2, \text{ we get}$$

We arrive at the expression

$$\int(\Delta P_m - \Delta P_e)dt = J\omega_0\Delta\omega \quad (2.9)$$

By setting  $2H = J\omega_0$ , gives

$$\int(\Delta P_m - \Delta P_e)dt = 2H\Delta\omega \quad (2.10)$$

Hence the relationship between  $\Delta P_a$  and  $\Delta\omega$  is found to be

$$\frac{\partial\Delta\omega}{\partial t} = \frac{1}{2H}(\Delta P_m - \Delta P_e) = \frac{1}{2H}\Delta P_a \quad (2.11)$$

By re-writing the equation above the signal  $\Delta\omega$  is obtained next:

$$\Delta\omega = \frac{1}{2H}\int(\Delta P_m - \Delta P_e)\partial t = \frac{1}{2H}\int\Delta P_a\partial t \quad (2.12)$$

From the equation above we can get the integral of  $\Delta P_m$ :

$$\int\Delta P_m\partial t = 2H\Delta\omega + \int\Delta P_e\partial t \quad (2.13)$$

Taking Laplace transform with suitable rearrangement leads to:

$$\frac{\Delta\hat{P}_m}{2Hs} = \Delta\Omega + \frac{\Delta\hat{P}_e}{2Hs} \quad (2.14)$$

Where  $\Delta\hat{P}_m$  and  $\Delta\hat{P}_e$  are Laplace transform of  $\Delta P_m$  and  $\Delta P_e$  respectively.

From equation (2.14), we can get the signal  $\frac{\Delta\hat{P}_m}{2Hs}$  (at point D in Figure. 4) by summing the signal  $\Delta\omega$  (from point C in Figure. 4) and the signal  $\frac{\Delta\hat{P}_e}{2Hs}$  (from point F in Figure. 4). But in reality the signal  $\frac{\Delta\hat{P}_m}{2Hs}$  contains torsional oscillations if no filter is used. Due to the relatively slow change of mechanical power  $\Delta P_m$ , the signal  $\frac{\Delta\hat{P}_m}{2Hs}$  can be conditioned with ramp-tracking filter in order to attenuate torsional frequencies noise. So the final signal  $\frac{\Delta\hat{P}_a}{2Hs}$  (point G in Figure 2.4) is given by the equation below:

$$\Delta\Omega = \frac{\Delta\hat{P}_a}{2Hs} = G(s) \left[ \frac{\Delta\hat{P}_e}{2Hs} + \Delta\Omega \right] - \frac{\Delta\hat{P}_e}{2Hs} \quad (2.15)$$

Where  $G(s) = \left[ \frac{(1+sT_g)}{(1+sT_o)^M} \right]^N$  is the ramp-tracking filter shown in Figure2.4 between points D and E.

After obtaining the signal of the integral-of-accelerating power signal, we can use the phase compensation component and stabilizer gain component to generate the phase and magnitude of PSS output signal  $V_s$ .

In the following we give more detailed description for various components of PSS.

As shown in Figure 2.4, the stabilizer includes two input signals: the rotor speed signal  $\omega$  at point A and electrical power  $P_e$  at point B.

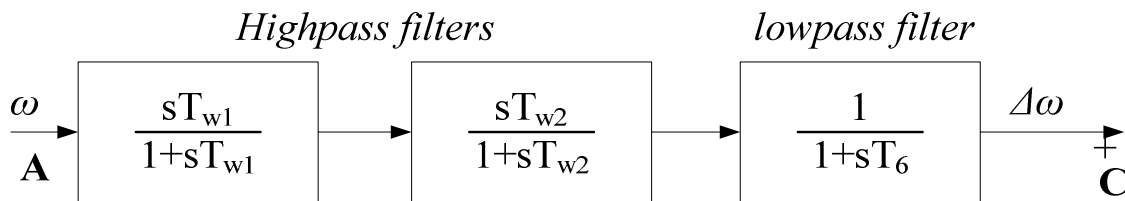

**Figure 2.5 High-pass and Low-pass filters for rotor speed input**

In Figure 2.5 above, from A to C there are two high-pass filters and a low-pass filter that

remove the average speed level, producing the rotor speed change  $\Delta\omega$  signal and eliminate the high frequency noise. The parameters of  $T_{w1}, T_{w2}$  and  $T_6$  are the time constant of these filters.

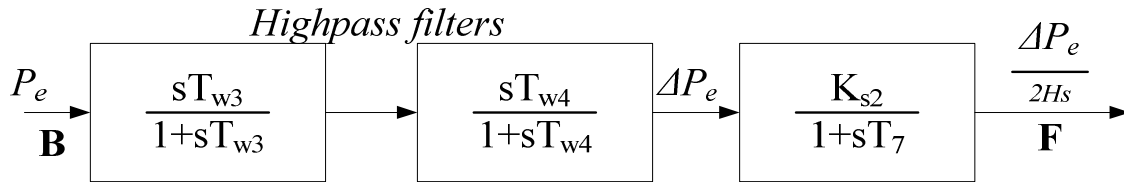

**Figure 2.6 High-pass filter and Integrator for electrical power input**

In Figure 2.6 above, from B to F there are two high-pass filters and an integrator which produce the electrical power change  $\Delta P_e$  and integrate it to obtaining  $\frac{\Delta P_e}{2Hs}$ . In the block  $K_{s2} = T_7/2H$ ,  $T_{w3}$  and  $T_{w4}$  are the time constant for the high pass filter, and  $T_7$  is the time constant for the low pass filter within the integrator.

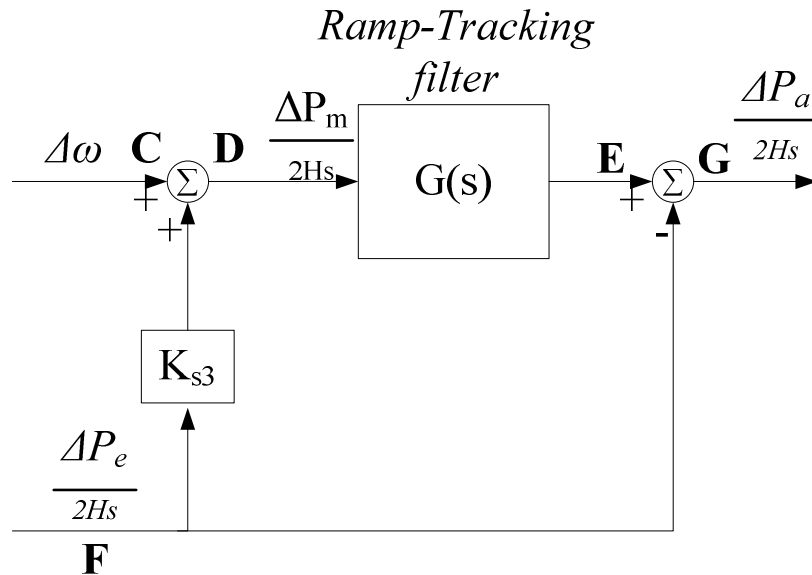

**Figure 2.7 Ramp-Tracking filter**

In Figure 2.7, on point D the signal  $\Delta\omega$  and  $\frac{\Delta P_e}{2Hs}$  are summed together. According to function (2.16), this mixed signal passes the ramp tracking filter, and then subtracts the signal  $\frac{\Delta P_e}{2Hs}$  at

point E. the end result is the integral-of-accelerating power signal  $\frac{\Delta P_a}{2Hs}$  on point G.

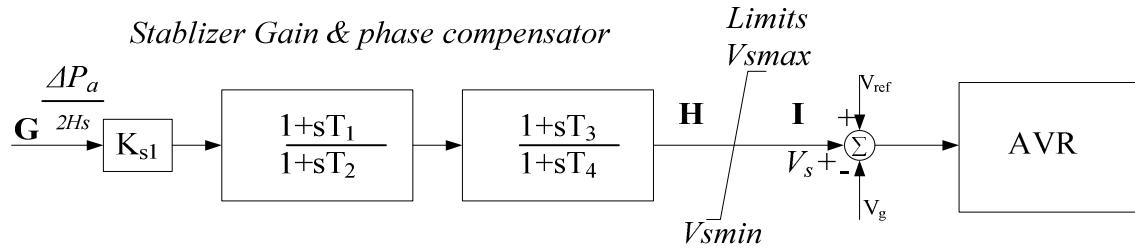

**Figure 2.8 Stabilizer Gain and Phase Compensator**

As shown in Figure 2.8, from point G to point H is the stabilizer gain  $K_{s1}$  plus phase compensator. They are used to adjust the PSS output signal. The output signal from point H is limited by the terminal voltage limiter so as to avoid producing an overvoltage condition. Then the signal  $V_s$  from I point is added into the input terminal of the AVR.

### 3. Conclusion

As described above, there are two functions of PSS. One is to estimate the oscillations of the rotor angle by analyzing the rotor speed and electrical power. The other one is to generate the reference signal  $V_s$  to AVR in order to increase closed-loop system damping ratio and eliminate the rotor angle oscillations. Nowadays the PSS2A(B) model is widely used in power system control. By setting the parameters of the PSS we can construct various PSS to fit different applications so as to improve the system stability.

## 2.2 Summary

As described above, there are two goals of this power control system. One is to keep the generator output voltage  $V_g$  stable at the set point; the other one is to reduce the rotor oscillation. To keep  $V_g$  stable, we use the Automatic Voltage Regulator. To reduce the rotor angle oscillation, we use PSS to track the rotor angle oscillation and produce suitable reference signal  $V_s$  to AVR

in order to increase closed-loop system damping ratio.

# CHAPTER 3 POWER CONTROL SYSTEM MODEL

## 3.1 Nonlinear Model

As described in chapter 2, generator, AVR and PSS are three essential part of the system. To effectively control the system, the mathematical model is very important. This chapter will focus on the modeling part f the control system.

### Generator model

Generally, the generator is a synchronous machine. For simplicity, the following figure illustrates the schematic synchronous machine.

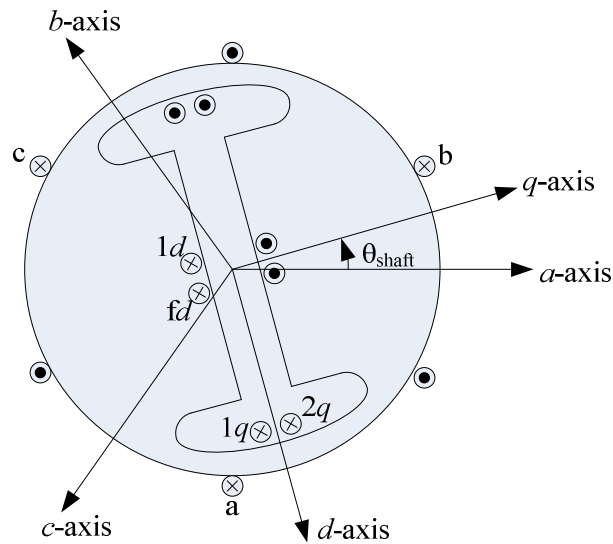

**Figure 3.1 Schematic synchronous machine [13]**

The laws of Kirchhoff, Faraday, and Newton induce the following dynamic equations:

$$v_a = i_a v_s + \frac{d\lambda_a}{dt}; \quad v_b = i_b v_s + \frac{d\lambda_b}{dt}; \quad v_c = i_c v_s + \frac{d\lambda_c}{dt} \quad (3.1)$$

$$v_{fd} = i_{fd} v_{fd} + \frac{d\lambda_{fd}}{dt}; \quad v_{1d} = i_{1d} v_{1d} + \frac{d\lambda_{1d}}{dt} \quad (3.2)$$



$$v_{1q} = i_{1q}v_{1q} + \frac{d\lambda_{1q}}{dt}; \quad v_{2q} = i_{2q}v_{2q} + \frac{d\lambda_{2q}}{dt} \quad (3.3)$$

$$\frac{d\theta_{shaft}}{dt} = \frac{2}{P}\omega; \quad J\frac{2}{P}\frac{d\omega}{dt} = T_m - T_e - T_{fw} \quad (3.4)$$

The physical meanings of the above symbols are summarized in the next table.

Table 3-1 Symbol list

$v_a, v_b, v_c$	Voltage on three phases
$v_{fd}$	Field winding voltage
$v_{1d}$	Voltage of damping winding on d-axis
$v_{1q}, v_{2q}$	Voltage of damping winding on q-axis
$\lambda$	flux linkage
<b>J</b>	inertia constant
<b>P</b>	the number of magnetic poles per phase
$T_m$	the mechanical torque applied to the shaft
$T_{fw}$	a friction windage torque
<b>r</b>	winding resistance
$T_e$	the torque of electrical origin

The equations above provide the basic relationships among flux linkage, field voltage, phase voltage and torque. By convention, Park's transformation is often employed to facilitate the numerical computation which is given by:

$$\mathbf{v}_{dq0} \triangleq \mathbf{T}_{dq0}\mathbf{v}_{abc} \quad (3.5)$$

$$\mathbf{I}_{dq0} \triangleq \mathbf{T}_{dq0}\mathbf{I}_{abc} \quad (3.6)$$

$$\boldsymbol{\lambda}_{dq0} \triangleq \mathbf{T}_{dq0}\boldsymbol{\lambda}_{abc} \quad (3.7)$$

Where  $\mathbf{T}_{dq0}$  is the so called Park's Transformation matrix:

$$\mathbf{T}_{dq0} \triangleq \frac{2}{3} \begin{bmatrix} \sin\left(\frac{P}{2}\theta_{shaft}\right) & \sin\left(\frac{P}{2}\theta_{shaft} - \frac{2\pi}{3}\right) & \sin\left(\frac{P}{2}\theta_{shaft} + \frac{2\pi}{3}\right) \\ \cos\left(\frac{P}{2}\theta_{shaft}\right) & \cos\left(\frac{P}{2}\theta_{shaft} - \frac{2\pi}{3}\right) & \cos\left(\frac{P}{2}\theta_{shaft} + \frac{2\pi}{3}\right) \\ \frac{1}{2} & \frac{1}{2} & \frac{1}{2} \end{bmatrix} \quad (3.8)$$

The complete mathematical model can be derived using the Park transformation in (3.5)-(3.7) and dynamic equations in (3.1)-(3.4). The One-Axis model below is the reduced-order model

which eliminated the stator and all three fast damper-winding dynamics [13]. All the parameters are scaled in per unit. A brief description is given as follows:

For synchronous machine model, the voltage equation is given by:

$$T'_{d0} \frac{dE'_q}{dt} = -E'_q - (X_d - X'_d)I_d + E_{fd} \quad (3.9)$$

$$\frac{d\delta}{dt} = \omega - \omega_s \quad (3.10)$$

where  $T'_{d0}$  is a scalar different from  $T_{d0}$ .

For torque (power flow) equation we have:

$$\frac{2H}{\omega_s} \frac{d\omega}{dt} = T_M - E'_q - (X_q - X'_d)I_d I_q - T_{FW} \quad (3.11)$$

For voltage regulator equations these hold:

$$T_E \frac{dE_{fd}}{dt} = -(K_E + S_E(E_{fd}))E_{fd} + V_R \quad (3.12)$$

$$T_F \frac{dR_f}{dt} = -R_f + \frac{K_F}{T_F} E_{fd} \quad (3.13)$$

$$T_A \frac{dV_R}{dt} = -V_R + K_A R_f - \frac{K_A K_F}{T_F} E_{fd} + K_A (V_{ref} - V_t) \quad (3.14)$$

For turbine and speed governor equations we have

$$T_{CH} \frac{dT_M}{dt} = -T_M + P_{SV} \quad (3.15)$$

$$T_{SV} \frac{dP_{SV}}{dt} = -P_{SV} + P_C - \frac{1}{R_D} \left( \frac{\omega}{\omega_s} - 1 \right) \quad (3.16)$$

If the generator connected with infinite bus, then:

$$0 = (R_s + R_e)I_d - (X_q + X_{ep})I_q + V_s \sin(\delta - \theta_{vs}) \quad (3.17)$$

$$0 = (R_s + R_e)I_q + (X'_d + X_{ep})I_d - E'_q + V_s \cos(\delta - \theta_{vs}) \quad (3.18)$$

$$-R_s I_d + X_q I_q = V_d = R_e I_d - X_{ep} I_q + V_s \sin(\delta - \theta_{vs}) \quad (3.19)$$

$$-R_s I_q + E'_q - X_d I_d = V_q = R_e I_q + X_{ep} I_d + V_s \cos(\delta - \theta_{vs}) \quad (3.20)$$

$$V_t = \sqrt{V_d^2 + V_q^2} \quad (3.21)$$

The following summarizes the physical meaning of the symbols used above

Table 3-2 Symbol list

$T'_{d0}$	open circuit transient d-Axis time constant (given by manufacturer)
$E'_q$	excited voltage on q-Axis
$X_d$	d-Axis synchronous reactance (given by manufacturer)
$X'_d$	d-Axis transient reactance (given by manufacturer)
$I_d$	d-Axis current
$E_{fd}$	field voltage
$\delta$	power angle(torque angle)
$\omega$	shaft speed
$\omega_s$	rated shaft speed
$H$	shaft inertia constant(given by manufacturer)
$T_M$	mechanic torque from turbine
$I_q$	q-Axis current
$X_q$	q-Axis synchronous reactance (given by manufacturer)
$T_{FW}$	friction torque
$T_E$	Electrical magnetic torque
$R_s$	stator resistance
$R_e$	infinite bus equivalent resistance
$V_s$	infinite bus voltage on steady state
$X_{ep}$	infinite bus equivalent reactance
$\theta_{vs}$	start angle between q-Axis and a-Axis
$V_q$	q-Axis voltage
$V_d$	d-Axis voltage

### 3.2 Linearized Model

The aforementioned model is nonlinear. It clearly indicates all the relationship between different parameters. But the nonlinear dynamic model of synchronous machine is too sophisticated to be used directly in AVR and PSS. Thus, the simplified linear model becomes

very important and is also more convenient to use in controller design. The following simplified linear model is commonly used [14]:

$$\Delta E'_q = \frac{K_3}{1+K_3T'_{d0}s} \Delta E_{FD} - \frac{K_3K_4}{1+K_3T'_{d0}s} \Delta \delta \quad (3.22)$$

$$\Delta T_e = K_1 \Delta \delta + K_2 \Delta E'_q ; \Delta V_t = K_5 \Delta \delta + K_6 \Delta E'_q \quad (3.23)$$

$$2H \Delta \dot{\omega} = \Delta T_m - \Delta T_e - \Delta T_D ; \Delta T_D = D \Delta \omega \quad (3.24)$$

$$\Delta \delta = \iint \Delta \omega ; H \triangleq \frac{\frac{1}{2} J (\omega_{BP})^2}{S_B} \quad (3.25)$$

The notation “ $\Delta$ ” means the small perturbation of each variable or signal. All variables and parameters are summarized into the following table.

Table 3-3 Symbol list

parameter	function
$E_{FD}$	field winding voltage that from AVR output
$\delta$	power angle
$T_e$	electromagnetic torque
$T_m$	mechanical torque from turbine
$T_D$	damping torque
$V_t$	generator terminal voltage
$E'_q$	the excited voltage
$T'_{d0}$	d-Axis transient time constant( provided by manufacturer)
$H$	the initial of the turbine and Shafter

There are six parameters ( $K_1, K_2, K_3, K_4, K_5, K_6$ ) in the simplified linear model, which depend on the physical parameters of the synchronous machine and the infinite power grid. [14]

### Automatic Voltage Regulator(AVR)

Accroding to IEEE standard there are many different kinds of AVR. But commonly used AVR nowadays is Type-AC8B AVR [11] shown in Figure 3.2.

According to the diagram the transfer function from the summing point to output is

$$AVR = 0.0066K_G(K_p + \frac{K_I}{s} + \frac{sK_D}{1+sT_D})V_p \frac{1}{1+sT_A} \frac{1}{T_E+K_E+S_E} \quad (3.26)$$

Where the parameters are described in table 3-4

Table 3-4 Symbol list

Parameters	function
$K_G$	Loop gain of AVR
$K_P$	AVR proportion gain
$K_I$	AVR integral gain
$K_D$	AVR derivation gain
$T_D$	AVR time constant
$V_P$	Exciter supply power
$T_A$	Exciter amplifier time constant (typical value is 0)
$T_E, K_E, S_E$	the exciter parameters given by manufacturer

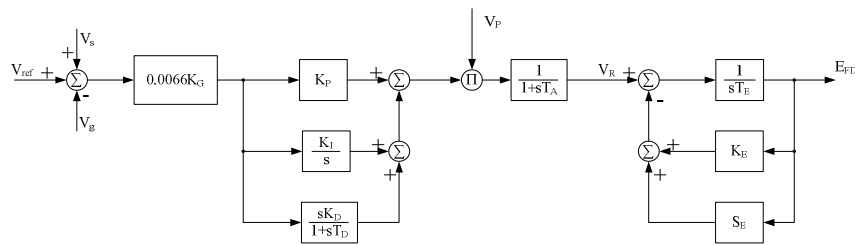

Figure 3.2 Type-AC8B AVR

This AVR is made up of PID controller and exciter. The front part

$$0.0066K_G(K_p + \frac{K_I}{s} + \frac{sK_D}{1+sT_D}) \quad (3.27)$$

is the transfer function of PID controller; the last part

$$V_p \frac{1}{1+sT_A} \frac{1}{T_E+K_E+S_E} \quad (3.28)$$

is the exciter transfer function

### Power System Stabilizer Model

According to the description in chapter 2, the function of PSS is to analyze the  $\Delta\omega$  and compensate the phase lag in AVR so as to make the  $\Delta T_e$  in phase with  $\Delta\omega$ .

So the transfer function can be simplified as follows:

$$\text{PSS} = K_{s1} \frac{1+sT_1}{1+sT_2} \frac{1+sT_3}{1+sT_4} \frac{1+sT_{10}}{1+sT_{11}} \quad (3.29)$$

Where it contains a gain compensator and phase compensator.

Table 3-5 Symbol list

$K_{s1}$	PSS gain compensator
$T_1$	PSS phase compensator parameters
$T_2$	PSS phase compensator parameters
$T_3$	PSS phase compensator parameters
$T_4$	PSS phase compensator parameters
$T_{10}$	PSS phase compensator parameters
$T_{11}$	PSS phase compensator parameters

### System Block Diagram

Based on the above equations the diagram of the linearized block synchronous generator control system is given next

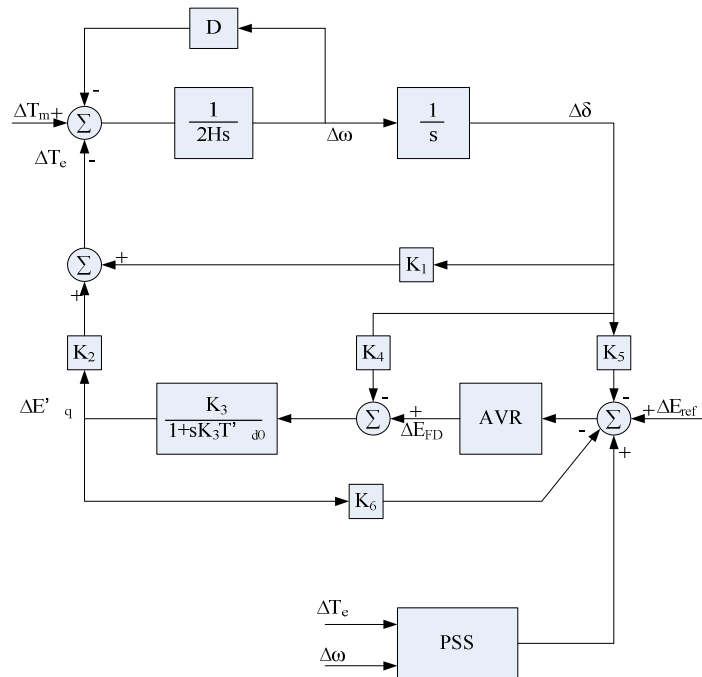

Figure 3.3 Linearized block diagram of synchronous generator control system

### 3.3 Input and Output Relation

In the block above diagram, stabilization of the generator system is equivalent to stabilization of the power angle  $\delta$ , which means to reduce the oscillation of the rotor. In a short period, the mechanical torque  $T_m$  from turbine can be considered as constant because of the high inertia of turbine system. That means  $\Delta T_m = 0$ ; from equation (3.23) and equation (3.24),  $\delta$  is directly affected by electromagnetic torque  $T_e$  and damping torque  $T_D$ . From equation (3.24), damping torque always resists the change of rotor rotation speed  $\omega$ . And when the motor is built, the coefficient  $D$  is fixed. The key to increase the stability of the system is to control  $T_e$  in order to generate more damping. As from the above diagram, the maximum damping can be get when  $\Delta T_e$  changes in phase with  $\Delta\omega$ . However, the amplitude of  $\Delta T_e$  is also need to be taken into consideration. If the amplitude is too large, the damping will also decrease. So, it cannot be too large. Hence, we use frequency response method to adjust its phase and use root locus method to control its amplitude. According to the above block diagram, the parameters that we can adjust are in AVR block and PSS block. AVR block is used to control the output voltage of the generator. Its goal is to make the output voltage quickly track the reference voltage. So, its parameters usually have been fixed before PSS is equipped in the whole control system. Thus, we only have to adjust the parameters in PSS block.

In PSS block, the input signal of PSS is electrical power  $P_e$  and rotor speed  $\omega$ , according to PSS structure described before. Because it only use the AC value of these two signal,  $P_e$  and  $\omega$  can be replaced by  $\Delta P_e$  and  $\Delta\omega$ . And in per unit system,  $\Delta P_e = \Delta T_e$ . So, the two input signals of PSS can be  $\Delta T_e$  and  $\Delta\omega$ .

### **System Transfer Function in Absence of PSS**

According to the basic equations given in (3.22)-(3.26), the relation between  $\Delta T_e$  and  $\Delta\omega$

without PSS is:

$$\Delta T_e = \left(K_1 - \frac{K_2 K_3 K_4}{1+sK_3 T'_{d0}}\right) \frac{\Delta\omega}{s} + \frac{K_3}{1+sK_3 T'_{d0}} \Delta E_{FD} \quad (3.30)$$

$$\Delta E_{FD} = \frac{-(K_5 - \frac{K_3 K_4 K_6}{1+sK_3 T'_{d0}})AVR}{s(1 + \frac{K_3 K_6}{1+sK_3 T'_{d0}} - AVR)} \Delta\omega \quad (3.31)$$

So, the close loop transfer function from  $\Delta\omega$  to  $\Delta T_e$  in absence of PSS is

$$G_0(s) = \frac{\Delta T_e}{\Delta\omega} = \left(K_1 - \frac{K_2 K_3 K_4}{1+sK_3 T'_{d0}}\right) \frac{1}{s} + \frac{K_3}{1+sK_3 T'_{d0}} \frac{-(K_5 - \frac{K_3 K_4 K_6}{1+sK_3 T'_{d0}})AVR}{s(1 + \frac{K_3 K_6}{1+sK_3 T'_{d0}} - AVR)} \quad (3.32)$$

### System Transfer Function in Presence of PSS

The relation between  $\Delta T_e$  and  $\Delta\omega$  in presence of PSS is given by:

$$\Delta E_{FD} = \frac{PSS \cdot AVR}{(1 + \frac{K_3 K_6}{1+sK_3 T'_{d0}} - AVR)} \Delta\omega - \frac{\left(K_5 - \frac{K_3 K_4 K_6}{1+sK_3 T'_{d0}}\right)AVR}{s(1 + \frac{K_3 K_6}{1+sK_3 T'_{d0}} - AVR)} \Delta\omega \quad (3.33)$$

$$PSS = K_{s1} \frac{1+sT_1}{1+sT_2} \frac{1+sT_3}{1+sT_4} \frac{1+sT_{10}}{1+sT_{11}} \quad (3.34)$$

$$\Delta T_e = \left(K_1 - \frac{K_2 K_3 K_4}{1+sK_3 T'_{d0}}\right) \frac{\Delta\omega}{s} - \frac{K_3}{1+sK_3 T'_{d0}} \frac{\left(K_5 - \frac{K_3 K_4 K_6}{1+sK_3 T'_{d0}}\right)AVR}{s(1 + \frac{K_3 K_6}{1+sK_3 T'_{d0}} - AVR)} \Delta\omega + \frac{K_3}{1+sK_3 T'_{d0}} \frac{PSS \cdot AVR}{(1 + \frac{K_3 K_6}{1+sK_3 T'_{d0}} - AVR)} \Delta\omega \quad (3.35)$$

$K_{s1}$  PSS gain

$T_1, T_2, T_3, T_4, T_{10}, T_{11}$  are PSS phase compensator parameters

Hence, the close loop transfer function from  $\Delta\omega$  to  $\Delta T_e$  in presence of PSS is given by

$$G_{PSS}(s) = \frac{\Delta T_e}{\Delta\omega} = \left(K_1 - \frac{K_2 K_3 K_4}{1+sK_3 T'_{d0}}\right) \frac{1}{s} + \frac{K_3}{1+sK_3 T'_{d0}} \frac{\left(K_5 - \frac{K_3 K_4 K_6}{1+sK_3 T'_{d0}}\right)AVR}{s(1 + \frac{K_3 K_6}{1+sK_3 T'_{d0}} - AVR)} + \frac{K_3}{1+sK_3 T'_{d0}} \frac{PSS \cdot AVR}{(1 + \frac{K_3 K_6}{1+sK_3 T'_{d0}} - AVR)} \quad (3.36)$$

According to the transfer function  $G_{PSS}(s)$ , the first two parts are the same as  $G_0(s)$ , and they are fixed. So, the last part of  $G_0(s)$  determines the stability of the generator system, which is what we can tune. The tuning method will be introduced in next chapter.



# CHAPTER 4 TUNING OF PSS WITH EXPERIMENTAL RESULTS

## 4.1 Tuning Schemes

PSS tuning is an important task. Correct parameters increases system stability margin, while other parameters may reduce stability margin of the system. On the other hand, tuning is also a complex task, because a power system is nonlinear and its operating condition varies. Tuning is the main tool for PSS to search for the correct parameters and to achieve satisfactory performance for the power system. Generically tuning is based on the characteristics of generator system. The following steps are guidelines to help us to search for the correct parameter setting in PSS:

Step1 obtain system frequency response in absent of PSS

Step2 obtain system frequency response when PSS is applied

Step3 use root-locus method to tune PSS gain so as to keep all roots on the left half plant.

### Frequency Response Tuning

As described before, the oscillation frequency zone is between 0.5Hz to 3Hz. To increase the system damping, the phase lag of compensated system in this frequency zone should be no more than 90 degree [8], which enables the system to achieve better performance. Hence, the phase compensation should focus on the range of 0.5Hz to 3Hz. The method developed in this thesis is to tune the PSS as follows.

Assume that the frequency response of  $G_{\text{noPSS}}(s)$  is available. The first step adjusts the

phase of the compensator by tuning the values of  $T_1, T_2, T_3, T_4, T_{10}, T_{11}$  of PSS. The second step tests the frequency response of  $G_{\text{withPSS}}(s)$  to check if the phase lag is less than 90 degree. If it does not meet the phase lag requirement, adjust again parameters  $T_1, T_2, T_3, T_4, T_{10}, T_{11}$ , and test again the frequency response of  $G_{\text{withPSS}}(s)$ . By doing these two steps repeatedly, the system phase lag can be reduced significantly. Once the phase is compensated, we can then turn to the third step -- root locus tuning.

### **Root Locus Tuning**

After all the PSS phase compensator parameters are fixed, plot the root-locus of  $G_{\text{withPSS}}(s)$ . From the root-locus, select the proper gain  $K_{s1}$  which assigns all roots to the open left half plane with the largest possible damping ratio.

## **4.2 Real System Tuning**

### **4.2.1 Tuning Conditions**

In the lab setup in PCS2000 Company, we have a generator control system, turbine control system, transmission line, loads distribution system, relay protection system. All these sub systems are assembled together to simulate a real power system. In the generator control system, the generator is 6.25 KVA 1800RPM 120/208 V. it is driven by turbine and it is control and excited by DECS-400 Digital Excitation Control System. The whole system structure in the lab is shown in Figure 4.1 and Figure 4.2.:

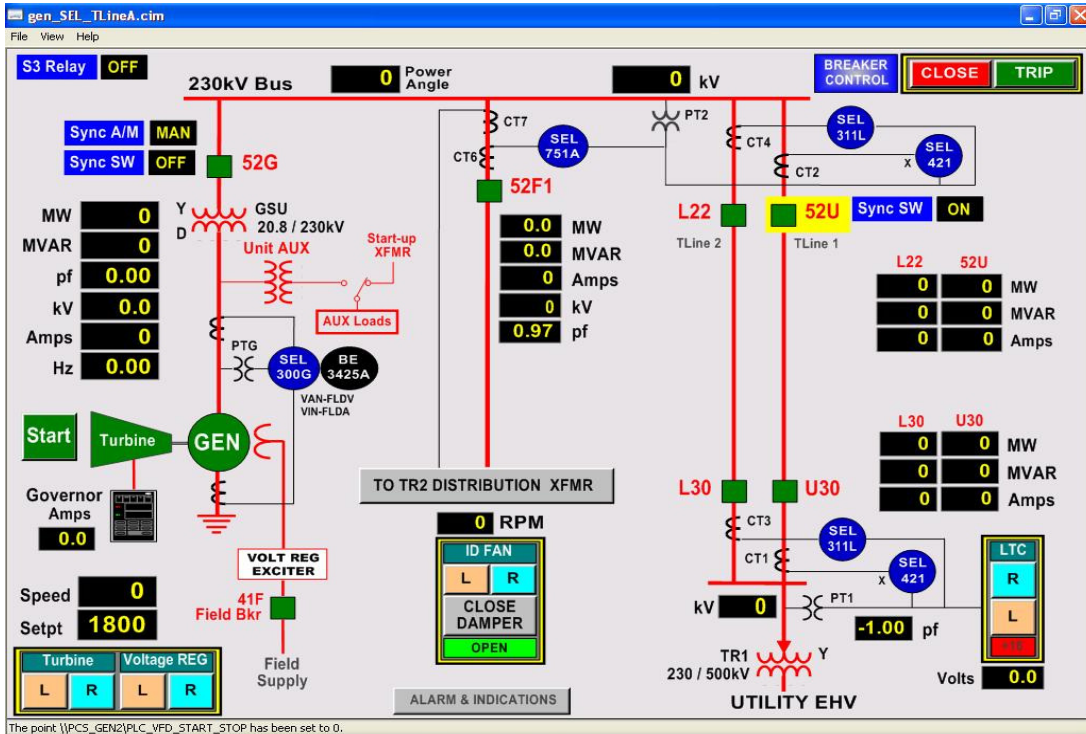

Figure 4.1 Generator system structure

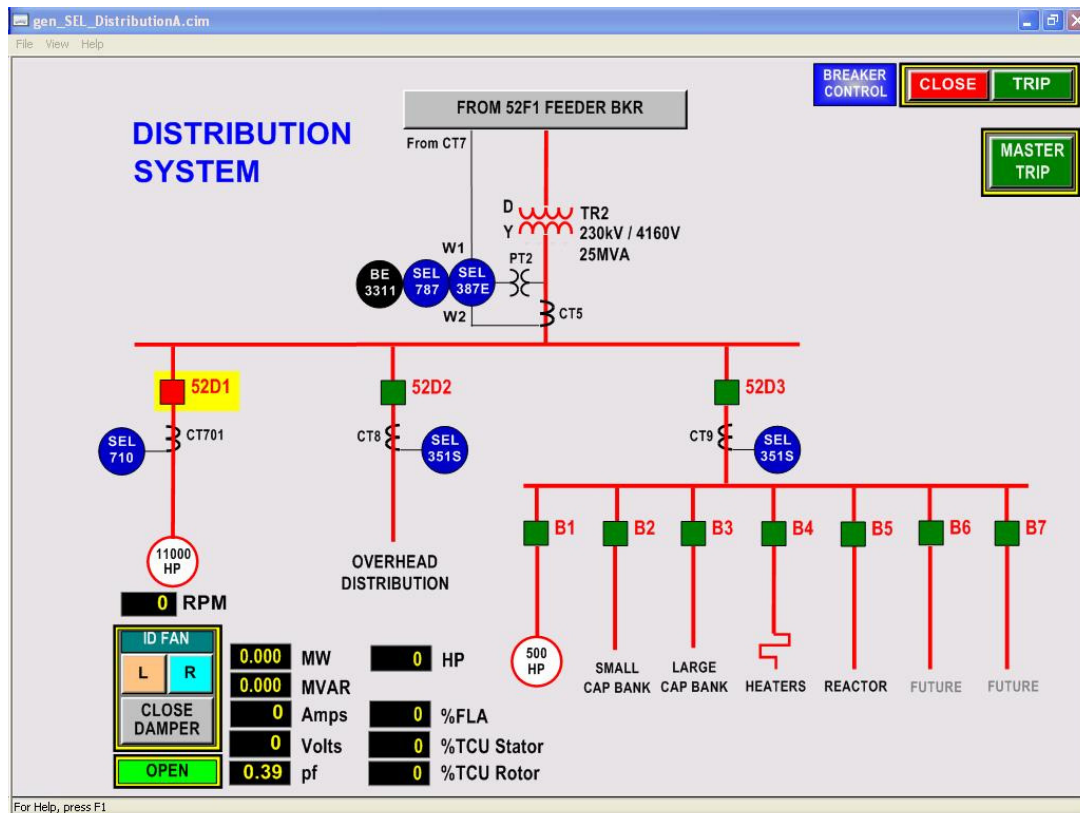

Figure 4.2 system load distribution

In the power lab, all the elements are real except the turbine that is substituted by an

induction motor. In Figure 4.1, a synchronous machine is used as a generator; it is driven by an induction motor. DECS-400 Digital Excitation Control System is applied to control the generator rotor field current so as to adjust the generator output. The generator can both run in isolation and synchronous mode with power grid. An LTC is used for generator to connect with the power grid. It can control the active and reactive power flow.

Figure 4.2 shows a different kind of system loads that are used for different test. The power system in the lab is quite complex, and it can be used for different experiments. But here we only use this system to tune the PSS. In this system, DECS-400 system is the most important equipment for PSS tuning.

### **4.2.2 Introduction to DECS400**

The DECS-400 Digital Excitation Control System is a microprocessor-based controller that offers excitation control, logic control, and optional power system stabilization in an integrated package. In addition, DECS-400 has a powerful analysis ability that gives us a useful tool to tune PSS. The following functions are used in PSS tuning.

#### **AVR**

The AVR structure in DECS-400 is shown below. It is used to control the output voltage by change the rotor field current. A PID controller is included in the AVR to monitor the generator output voltage and to track the reference signal.

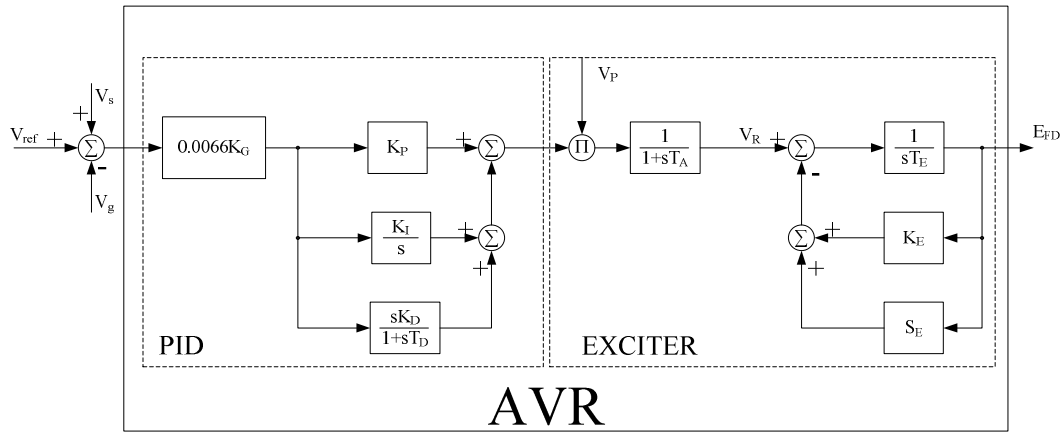

**Figure 4.3 AVR structure**

In PSS tuning, the output signal of PSS is added to the input summing point of AVR. When PSS is disabled, its output is zero. Field current is influenced only by  $V_{ref}$ , the voltage reference signal. When PSS is enabled, its output signal will be summed up with  $V_{ref}$  to control the field current.

## PSS

The optional onboard power system stabilizer is an IEEE-defined PSS2A, dual-input, “integral of accelerating power” stabilizer. It provides supplementary damping for low-frequency, local mode inter-area, and inter-unit oscillations in the range of 0.1 to 5.0 hertz. It can also be set up to respond only to frequency signal if required for unusual applications. Inputs required for PSS operation includes three phase voltages and two or three phase line currents.

## Analysis Function

With this function, DECS-400 can be used to perform and monitor on-line PSS and AVR testing. It can show two plots of signals on the screen at the same time. User selected data can be generated and the logged data can be stored in a file for later examination. The analysis function

contains frequency response and time response options. Frequency response option can be used to analyze the frequency response between two selected signals. Time response option can be used to test system step response.

### 4.2.3 Real System Tuning Scheme

In the real system, sometime the system parameters and block diagrams such as exciter structure and generator parameters are not completely provided by the manufacturer. Hence, we cannot tune the system by calculating the setting parameters from the system mathematic model. However, by the tuning scheme in 4.1, the most important information we have to know is the system frequency response of each block in the system. We can consider the following system:

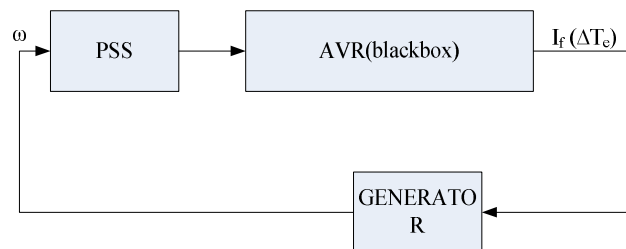

**Figure 4.4 Simplified system diagram for tuning**

We can consider the AVR model as a black box. Its input signal is from the PSS output. Let the shaft speed be  $\omega$ .  $\omega$  is from generator output. The AVR output signal is field winding current denoted by  $I_f$ . The way to know AVR is through analyzing its frequency response. We can quickly obtain the phase lag between the AVR input and output, i.e.,  $I_f$ , based on the Bode diagram. The parameters of the PSS phase compensator can then be tuned to compensate the phase lag of AVR. After completing the phase compensation, the final task is to tune the PSS gain that is set to zero first. The gain will be increased slowly until the system begins to oscillate,

and it will then be reduce to one-third. This is the right gain and provides the maximum damping to the system [8]

## 4.2.4 Tuning in Real System

### AVR Tuning

According to Figure 4.4, AVR connects PSS and GENERATOR in series. For this reason, AVR should be tuned to stabilize the system prior to PSS tuning, after then we can begin to tune PSS. By Figure 4.3, its left side shows the PID controller and the right side the exciter. Parameters of both exciter and generator are not provided by manufacturer. Hence, PID parameter tuning can only be achieved by experiments. In DECS-400, we can use step response to tune the PID parameter. The steps are described next.

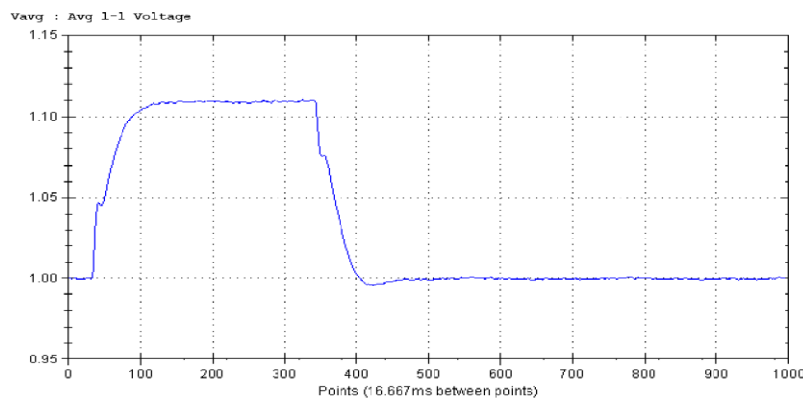

**Figure 4.5 Step response**

In the first step, the proportion parameter is increased and the step response is observed until the shortest settling time and lowest overshoot are achieved. The integration parameter is tuned in the second step by reducing the proportion parameter to 70% of its original value first. The integration parameter is then increased slowly and until the settling time and overshoot are

adequately reduced. If the responses are unsatisfactory, then the derivative parameter can be tuned. The step response of tuning AVR is shown below. The input signal is 10% of the set point. And from the step response, we can see the settling time is 1s and the overshoot is 0. After AVR tuning is complete, next is to obtain the frequency of AVR.

### AVR Frequency Response

By using the frequency response function in the DECS-400 software, we set summing point in Figure 2.1 as input signal and set field current  $I_f$  as the output signal. Then, the DECS-400 software will carry out the frequency response test from 10Hz to 0.1Hz.

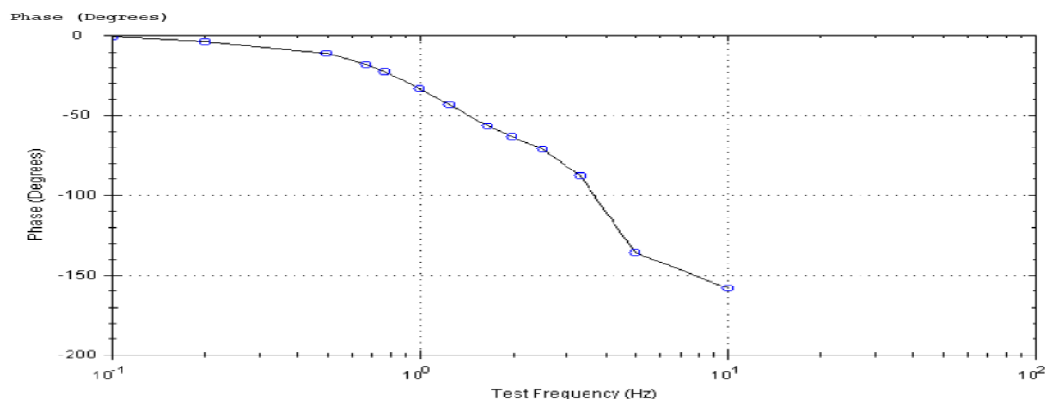

**Figure 4.6 Frequency response of AVR**

From Figure 4.6, the phase lag increases as the frequency increase. At 1Hz phase lag is 30 degree. While at 10 Hz it increases to 160 degree. Hence, we need lead compensator to compensate the phase lag in AVR. However, there is another phase lag in the control loop. It is phase lag of the PSS signal filter.

### PSS Signal Filter Phase Lag

Due to the filter used in PSS,  $\Delta\omega$  has phase lag. Hence, we have to consider the phase lag caused by filter. The setting of filter and the phase lag in the filter are shown below.



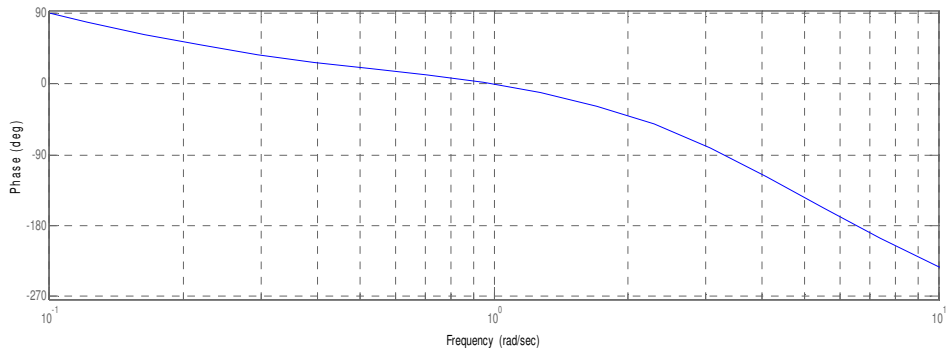

**Figure 4.7 PSS filter phase lag obtained by MATLAB**

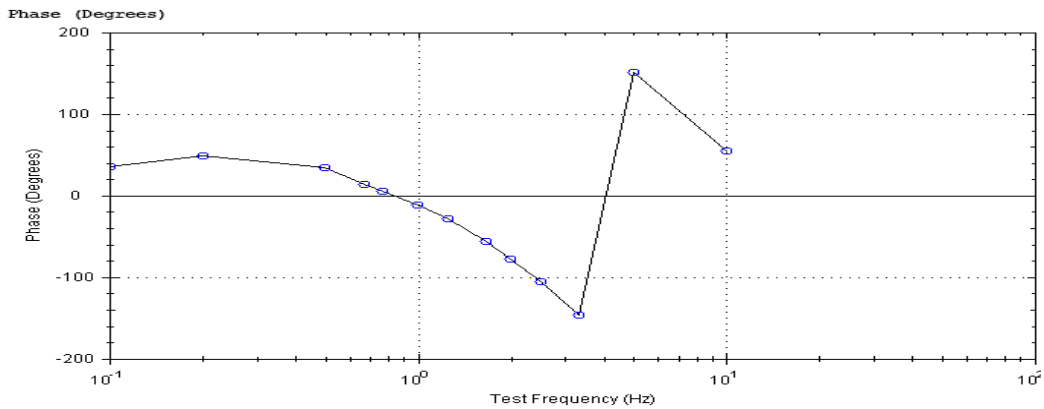

**Figure 4.8 PSS filter phase lag obtained by DECS-400**

Due to the limitation of the software, it can only show the phase from -180 degree to 180 degree. Hence, the last two points are actually -200 degree and -300 degree. Since the system is nonlinear, the MATLAB results are different from those of the real system. However this is not critical because we need to care about the phase only from 0.5Hz to 3Hz.

According to the frequency response obtained above, the system has about 180 phase lag at 3Hz.

After the entire phase lag is available, the next step is to design lead compensator.

### Lead Compensator Design for PSS

Recall the equation of PSS compensator:

$$PSS = K_{s1} \frac{1 + sT_1}{1 + sT_2} \frac{1 + sT_3}{1 + sT_4} \frac{1 + sT_{10}}{1 + sT_{11}}$$

The required phase lead can be achieved by setting  $T_1$ ,  $T_2$ ,  $T_3$ ,  $T_4$ ,  $T_{10}$ , and  $T_{11}$  to the correct values, and Matlab can be used to compute these parameters. The next figure shows the Bode diagram of the designed lead compensator.

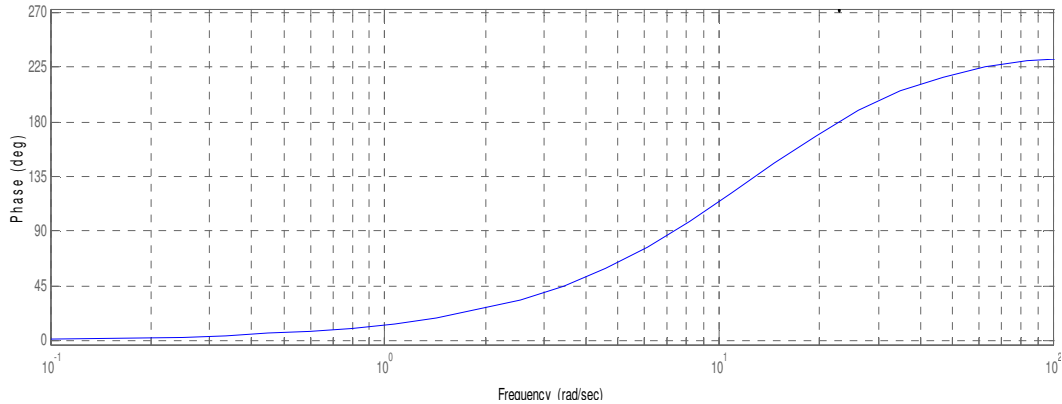

**Figure 4.9 Phase Compensator in MATLAB**

After the lead compensator is available, it can be programmed into DECS-400 PSS by setting the compensator parameters to the designed values, which can be tested using again the system frequency response. In fact, differences between the real system and MATLAB do exist, but they are not significant. We care more about the frequency response data between 0.5 Hz to 3 Hz. By combining the filter and lead compensator in PSS, the final frequency response of the PSS is shown below.

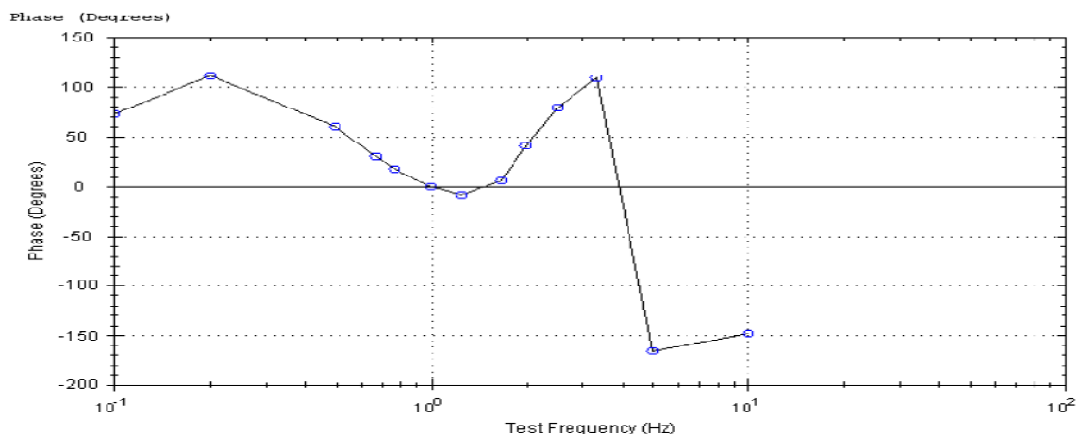
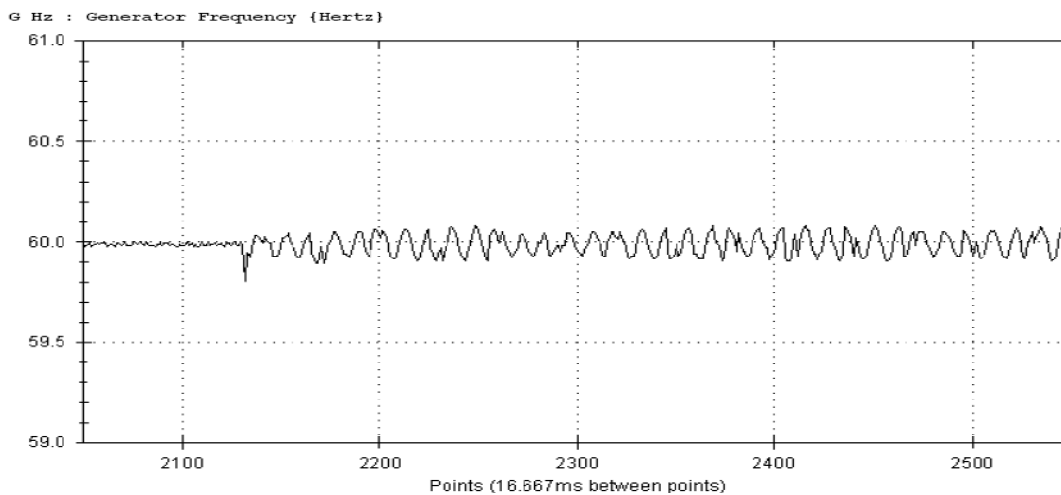

**Figure 4.10 Phase compensator in DECS-400**

Due to the limits of the software, it shows the phase only from -180 degree to 180 degree. Hence the phase should be 230 degree at 5Hz and 250 degree at 10Hz. By adding up the phase lead in PSS and phase lag in AVR, the phase lag from 0.5Hz to 3 Hz is now corrected to less than 90 degree. After finishing the phase compensation, we turn out attention to gain tuning in the PSS compensator.

### PSS Gain Test

Due to the lack of system parameters, root-locus method cannot be used in gain tuning. Hence, according to reference [8], we can obtain the gain by experiment. For safety, we set the gain  $K_{s1}$  to zero at the beginning, and then increase the gain slowly, until system become marginally stable (Figure 4.11) which causes the system to begin oscillation. After then, we reduce the gain to 1/3 of its value.



**Figure 4.11 System begins oscillating.**

### PSS Settings

The detailed settings of PSS are shown below based on the IEEE Type PSS2B model [11].

Table 4-1 PSS Settings

$T_{w1}$	10
$T_{w2}$	10
$T_{w3}$	10
$T_{w4}$	0
$T_1$	0.08
$T_2$	0.001
$T_3$	0.08
$T_4$	0.001
$T_6$	0
$T_7$	10
$T_8$	1
$T_9$	0.2
$T_{10}$	0.08
$T_{11}$	0.001
$K_{s2}$	5
$K_{s3}$	1
$K_{s1}$	15

### 4.3 Final Result of PSS Tuning

In the lab, the generator is 8KW, very easy to be perturbed by large loads. PSS can reduce angle oscillation of the generator rotor in presence of the disturbance. In fact we used 500Hp induction motor as the load in the lab experiment, and tested the generator performance by starting the induction motor. In addition we analyzed the frequency oscillation of the generator output which reflects the oscillation of the rotor angle. To illustrate the effectiveness of our PSS tuning, the turbine mechanic power is reduced to enlarge the rotor angle changes when generator is affected by the load disturbance

The following figures show the rotor oscillation of the generator when PSS is disabled and enabled.

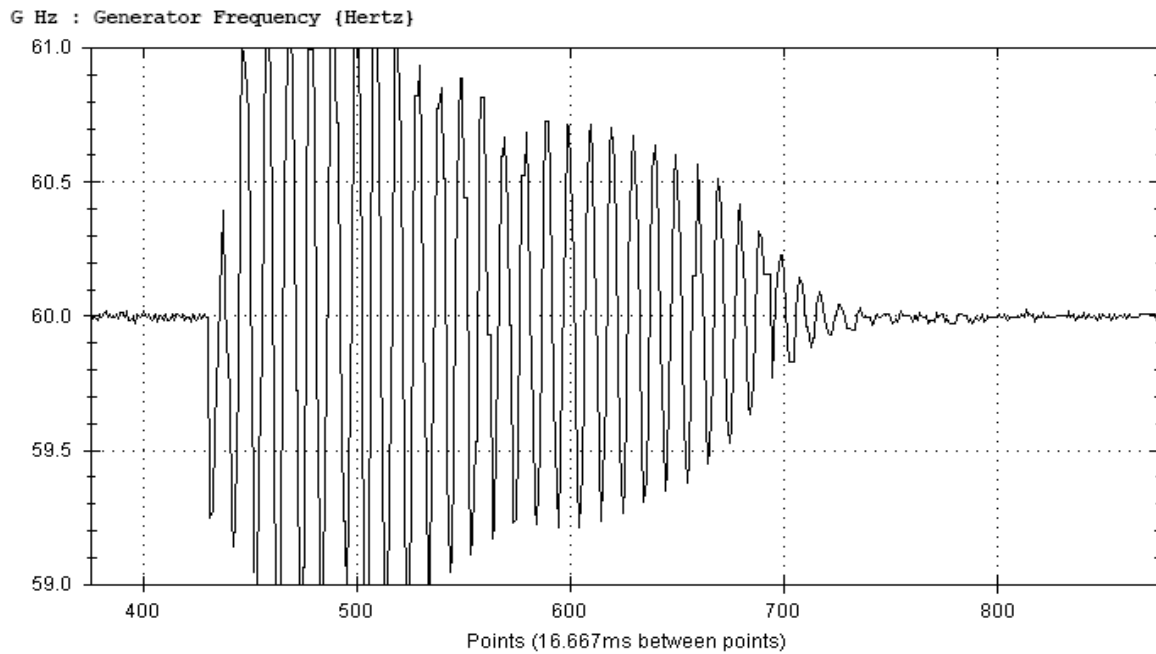

**Figure 4.12 Generator frequency under step load change without PSS equipped when turbine mechanic power is low**

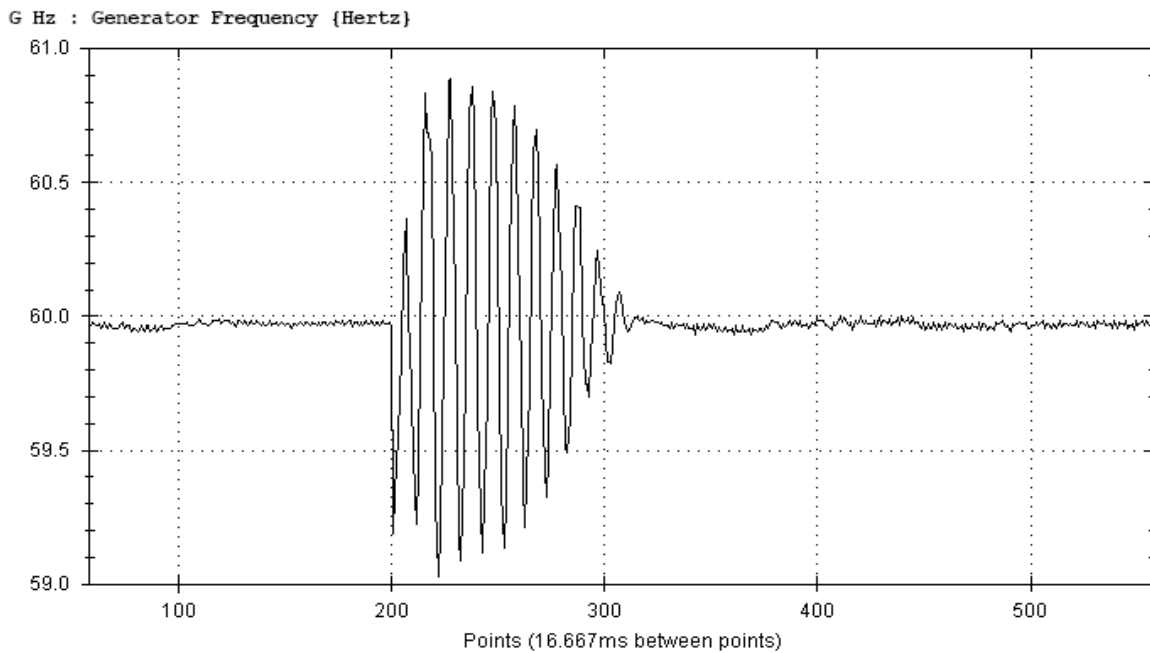

**Figure 4.13 Generator frequency under step load change with PSS equipped when turbine mechanic power is low**

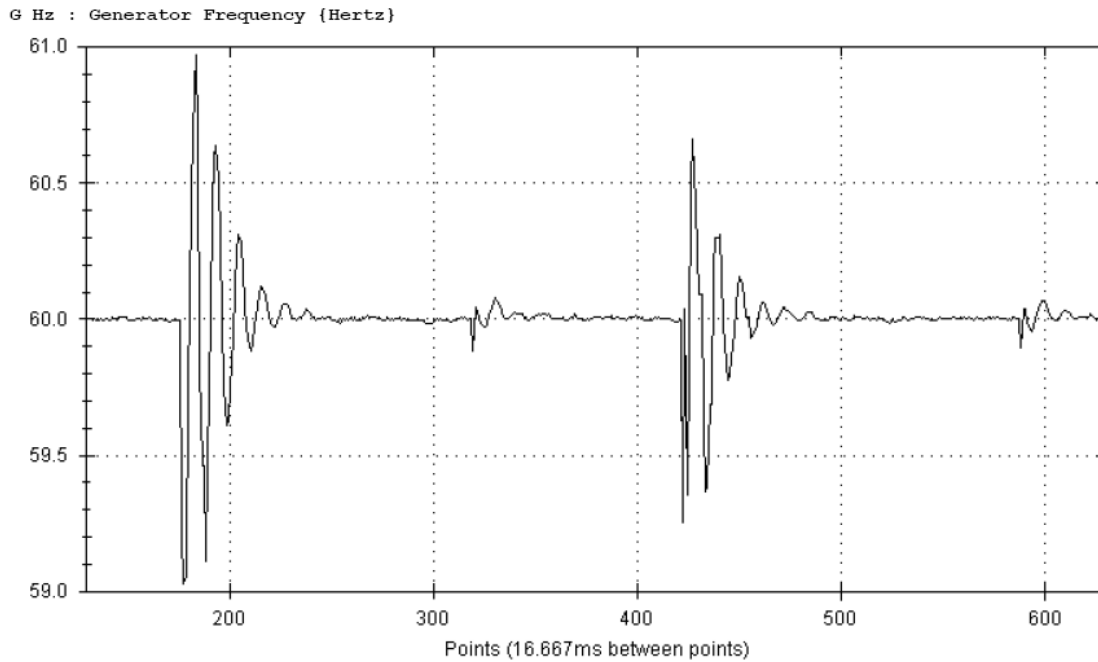

**Figure 4.14 Generator frequency under step load change without PSS equipped when turbine mechanic power is increased**

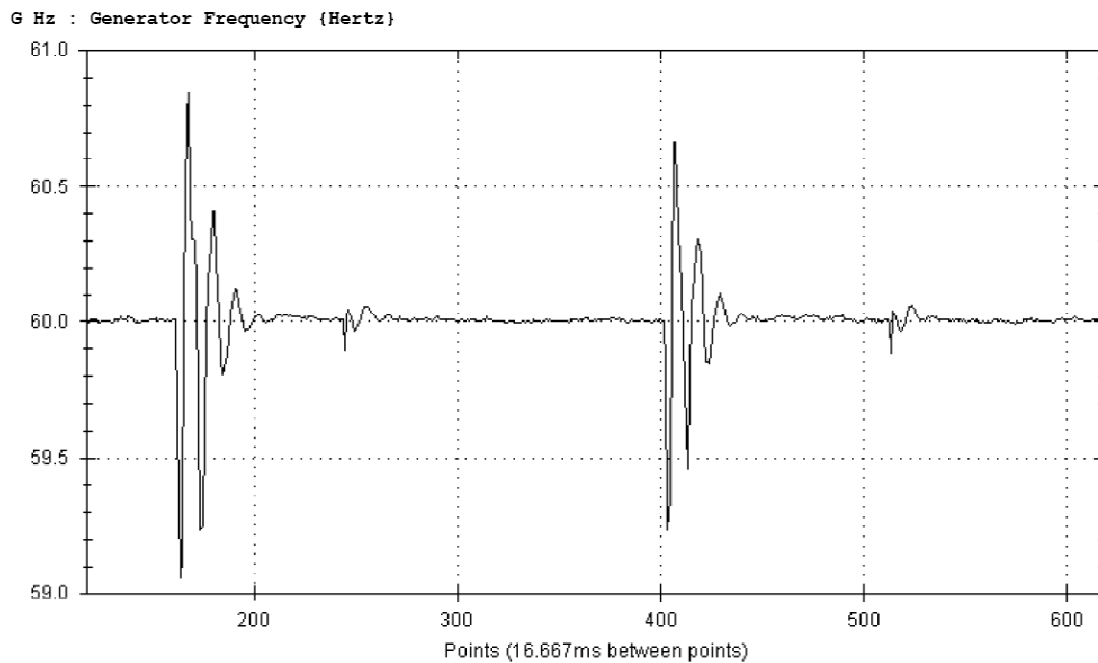

**Figure 4.15 Generator frequency under step load change with PSS equipped when turbine mechanic power is increased**

As it can be seen from the above results, the rotor angle oscillation is significantly reduced and the oscillation cycles become less than before when PSS is enabled. Moreover the system

damping is increased greatly that demonstrate the effective tuning scheme for PSS.

# CHAPTER 5 CONCLUSION

## 5.1 Work Complete

Power system is a complex nonlinear system. It is very hard to establish a complete mathematic model. Although the prediction of power requirement is more accurate than before, the random power oscillation in the power grid still cannot be controlled. As a result, the PSS is the most effective device to prevent these power oscillations in the power grid. In the thesis, we first introduced the typical feedback power control system. In the system, AVR is used to control generator output voltage by modulating the rotor excitation. PSS is equipped to aid damping to the oscillation by changing the reference signal of AVR. When system runs under AVR mode, the generator is the control plant. The PSS function is disabled and the output is zero. When PSS is enabled, the control plant becomes AVR and generator which are series connected. To effectively control the generator system, the mathematic models are derived. The one-axis model is the commonly used model for control. But it is still too complex. Base on this model, the simplified linearized model is obtained for control. The model clearly shows the relationship among excitation voltage, electrical power, shaft speed and angle. Besides, with the model of AVR and PSS, the system transfer function shows that when system is established, the parameters of AVR and generator are fixed. Only the parameters of PSS determine the stability of the system. By correctly tuning PSS system, damping ratio can be significantly increased. The traditional way of tuning PSS is using a computer to simulate the generator running in the system, which requires all the parameters of the system model. This method is very accurate when all the parameters are



correct and the models are known. However, to many small power plants, it is hard to fit these conditions. Therefore, the new method of tuning PSS overcomes these limitations. In the new tuning method, Generator and AVR are considered as the black box. By analyzing the frequency response between AVR input signal and generator field current, it can easily get the system phase lag and compensate it by tuning PSS lead compensator parameters. After compensate the phase lag, the compensator gain can be set up to 1/3 of its value that will cause the system to oscillate. By doing these steps, the system damping ratio can be effectively increased. Hence, the new tuning method is a quick and easily way to make PSS works.

## **5.2 Work to Be Done in the Future**

Although the new method is very easy and simple, it requires the equipment to have the ability to analyze the system frequency response and it needs the feedback signals are accurate and shown correctly. Otherwise, the tuning will not be accurate. Sometimes the feedback signals contain much noise due to the transducer's hardware. In most of the cases, due to the difference between idea transfer function and real hardware, the same settings in the PSS cannot get the same frequency response in real system as it shows in the MATLAB. Thus, it needs to do experiments iteratively to adjust the settings. Thus, this method only can make the PSS quickly applied in the system, but it is hard to let the system get the best damping ratio. To improve the efficiency of this PSS tuning method, there are two ways. One of the ways is to improve the accurate of the feedback signal by using high accuracy devices in transducer and PSS. Another way is increase the system sampling frequency so as to reduce the phase lag and increase feedback signal accuracy. PSS is a complex device, the tuning of PSS is not only base on the

plant but also relate to the PSS device itself. In real system, all the devices are not ideal. The correct system characteristics only can be obtained from experiments. Thus, based on the tuning method introduced in this thesis, the equipment that can analyze the correct system characteristics is very important. Only, the correct system characteristics can tune the PSS more accurate. Hence, there are still more problems waiting for engineers to solve.

# REFERENCES

- [1] Baohui Zhang , Linyan Cheng , Zhiguo Hao , Klimek, A. , Zhiqian Bo , Yonghui Deng, Gepin Yao , Jin Shu. Study on security protection of transmission section to prevent cascading tripping and its key technologies [J]. IEEE Transmission and Distribution Conference and Exposition, 2008:13-15
- [2] Novosel D, Begovic M, Mandani V. Shedding light on blackout [J]. IEEE Power&Energy, 2003, 2(1):32-43.
- [3] ZHANG Bao-hui. Strengthen the protection relay and urgency control system to improve the capability of security in the interconnected power network[J].Proceedings of the CSEE, 2004,24(7):1-6.
- [4] Manisha Dubey. Design of Genetic Algorithm Based Fuzzy Logic Power System Stabilizers in Multimachine Power System [J].Power System Technology and IEEE Power India Conference ,2008 :1-6
- [5] M.Bragard, N.Soltau, S.Thomas, R.W.DeDoncker, The Balance of Renewable Sources and User Demands in Grids: Power Electronics for Modular Battery Energy Storage Systems [J]. Power System Technology and IEEE Power India Conference, 2008:1-6
- [6] E.V. Larsen, D.A. Swann, Applying Power System Stabilizers Part I: General Concepts [J]. IEEE Power Apparatus and System, 1981: 3017-3024
- [7] E.V. Larsen, D.A. Swann, Applying Power System Stabilizers Part II: Performance Objectives and Tuning Concepts [J]. IEEE Power Apparatus and System, 1981: 3025-3033
- [8] E.V. Larsen, D.A. Swann, Applying Power System Stabilizers Part III: Practical Considerations [J]. IEEE Power Apparatus and System, 1981: 3034-3046
- [9] J.Jaeger, R.Krebs, Protection security assessment - An important task for system blackout prevention [J]. IEEE Power System Technology, 2010 International Conference 2010:1-6
- [10]G.R. Bérubé, L.M. Hajagos, Accelerating-Power Based Power System Stabilizers,Kestrel Power Engineering Ltd. Mississauga, Ontario, Canada,2008
- [11] IEEE Recommended Practice for Excitation System Models for Power System Stability Studies, ITTT Standard 421.5-2005, April 2006

- [12] F.P.deMello, L.N. Hannett, and J.M. Undrill, Practical Approaches to Supplementary Stabilizing from Accelerating Power, IEEE Trans., Vol. PAS-97, 1987:1515-1522
- [13] Peter W.Sauer, M.A.Pai, Power System Dynamics and Stability. Prentice-Hall, Inc. 1998
- [14] P.M.Anderson, A.A.Fouad, Power System Control and Stability, Institute of Electrical and Electronics Engineers, Inc. 2003
- [15] Instruction Manual for Digital Excitation Control System Decs-400, Basler Electric
- [16] Kiyong Kim, Mathematical Per-Unit Model Of The Decs400 Excitation System, Basler Electric Company, 2004
- [17] P.L Dandeno, A.N. Karas, K.R. McClymont, and W. Watson, “ Effect of High-Speed Rectifier Excitation Systems on Generator Stability Limits,” IEEE Trans., Vol. PAS-87.pp.190-201, January 1968
- [18] W.Watson and G.Manchur, “Experience with Supplementary Damping Signals for Generator Static Excitation Systems,” IEEE Trans., Vol. PAS-92, pp. 199-203,January/February 1973.
- [19] F.W. Key, W.H. South, “Design of a Power System Stabilizer Sensing Frequency Deviation”, IEEE Trans., Vol PAS-90, Mar/Apr 1971, pp 707-713.

# VITA

Bixiang Tang was born in Nanjing, P.R.China. He is the son of Huixin Tang and Xueqin Bi. He received the bachelor degree of electrical engineering from Jiangsu University in 2002. And later, he became a graduate student in Jiangsu University and got the master degree of electrical engineering in 2006. Then, he came to American and joined the Department of Electrical and Computer Engineering at Louisiana State University in 2009 in doctoral program. And he will be awarded the degree of Master of Science in Electrical Engineering in May 2011.