

2007

# Predictive data compression using adaptive arithmetic coding

Claudio Jose Iombo

*Louisiana State University and Agricultural and Mechanical College*

Follow this and additional works at: [https://digitalcommons.lsu.edu/gradschool\\_theses](https://digitalcommons.lsu.edu/gradschool_theses)



Part of the [Electrical and Computer Engineering Commons](#)

---

## Recommended Citation

Iombo, Claudio Jose, "Predictive data compression using adaptive arithmetic coding" (2007). *LSU Master's Theses*. 2717.  
[https://digitalcommons.lsu.edu/gradschool\\_theses/2717](https://digitalcommons.lsu.edu/gradschool_theses/2717)

This Thesis is brought to you for free and open access by the Graduate School at LSU Digital Commons. It has been accepted for inclusion in LSU Master's Theses by an authorized graduate school editor of LSU Digital Commons. For more information, please contact [gradetd@lsu.edu](mailto:gradetd@lsu.edu).

# PREDICTIVE DATA COMPRESSION USING ADAPTIVE ARITHMETIC CODING

A Thesis  
Submitted to the Graduate Faculty of the  
Louisiana State University and  
Agricultural and Mechanical College  
in partial fulfillment of the  
requirements for the degree of  
Master of Science in Electrical Engineering  
in  
The Department of Electrical Engineering

by  
Claudio Iombo  
EIT., B.S., Louisiana State University, 2003  
August 2007

# Table of Contents

Abstract .....	iv
Introduction.....	1
Types of Data.....	1
Data Compression System.....	2
What Is This Thesis About .....	3
Chapter 1 Information Theory.....	6
Information .....	6
Entropy.....	6
Joint and Conditional Entropy.....	7
Mutual Information .....	8
Chapter 2 Entropy Coding .....	10
Introduction .....	10
Prefix Codes.....	10
Kraft's Inequality.....	11
Huffman Coding .....	12
Alternate Implementation .....	13
Adaptive Huffman .....	14
Arithmetic Coding.....	16
Advantages of Arithmetic Coding.....	16
Disadvantages of Arithmetic Coding .....	17
Optimality of Arithmetic Coding.....	19
Adaptive Arithmetic Coding.....	20
Chapter 3 Data Modeling.....	23
Introduction .....	23
What Do We Know About The Data.....	23
Worst Case Scenario .....	24
Best Case Scenario .....	24
Application to Compression .....	24
Sources .....	24
Markov Models.....	25
Adaptive Arithmetic Compression Using Data Models.....	28
Chapter 4 Implementation of Arithmetic Coder.....	32
Introduction .....	32
Modeler .....	32
Encoder.....	33
E1 and E2 Scaling .....	33
E3 Scaling.....	35
Decoder.....	37

Modified Arithmetic Coder .....	39
Modeler .....	40
Encoder.....	40
Decoder .....	42
Chapter 5 Implementation of Huffman Coding.....	45
Node.....	45
Tree.....	45
Tree Operations .....	46
Encode .....	51
Decode.....	52
Chapter 6 Simulation Results .....	57
Files.....	57
Results .....	57
Discussion.....	59
Conclusions and Future Work .....	61
Bibliography.....	62
Vita .....	64

# **Abstract**

The commonly used data compression techniques do not necessarily provide maximal compression and neither do they define the most efficient framework for transmission of data. In this thesis we investigate variants of the standard compression algorithms that use the strategy of partitioning of the data to be compressed. Doing so not only increases the compression ratio in many instances, it also reduces the maximum data block size for transmission. The partitioning of the data is made using a Markov model to predict if doing so would result in increased compression ratio. Experiments have been performed on text files comparing the new scheme to adaptive Huffman and arithmetic coding methods. The adaptive Huffman method has been implemented in a new way by combining the FGK method with Vitter's implicit ordering of nodes.

# **Introduction**

We deal with information every day. It comes in many forms. We watch television, use computers, and listen to radio. This information requires a large amount of storage and bandwidth and it needs to be digitized in order to be processed. Doing so eases processing of data and reduces errors by making it less susceptible to noise. Maximum sampling rates are typically used to represent these signals in digital form, and this does not take into account the periods of inactivity and redundancy that exist in most messages. For example, 8 bits are used to represent text alphabet symbol, although has been shown that as few as four bits are enough to convey the same information [6]. The same can be said about video data which contains regions where little change occurs from frame to frame. Using this knowledge, the data can be represented using fewer bits. Data compression is the means developed to minimize the amount of bits used to represent data. The reduction of storage and bandwidth is measured against the increase in processing power required to compress the message. We must keep this tradeoff in mind when designing a system for data compression.

## **Types of Data**

Data to be compressed can be divided into symbolic or diffuse data [6]. Symbolic data is data that can be discerned by the human eye. These are combinations of symbols, characters or marks. Examples of this type of data are text and numeric data. Unlike the symbolic data, diffuse data cannot be discerned by the human eye. The meaning of the data is stored in its structure and cannot be easily extracted. Examples of this type of data are speech, image, and video data.

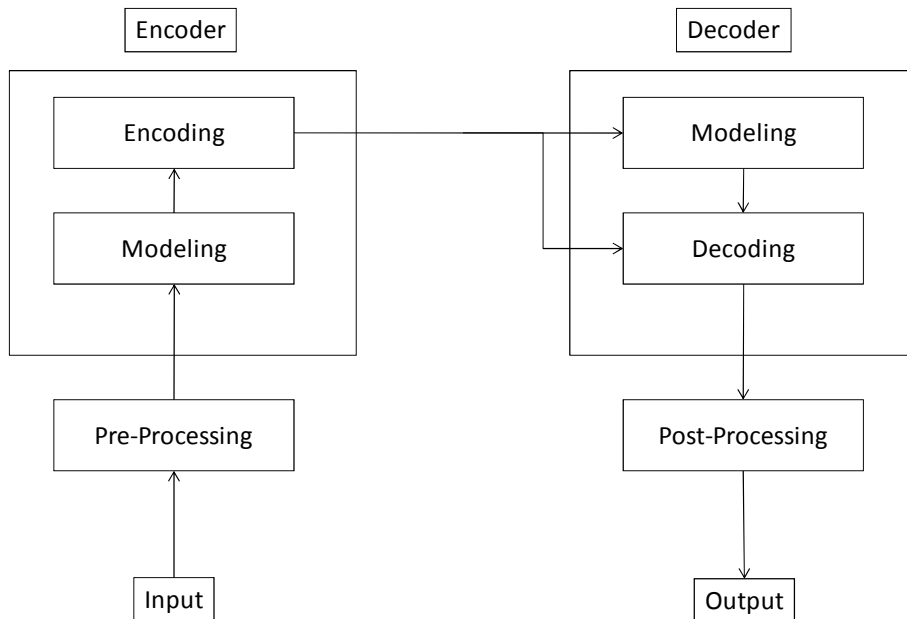
The approaches taken to compress diffuse and symbolic data are different but not exclusive. In symbolic data the approach most taken is reduction of redundancy. This is an approach that uses lossless compression techniques, meaning that the compression process is reversible with 100 percent accuracy. Lossless compression algorithms include entropy coding and dictionary based compression. For diffuse data the approach to compression is the removal of unnecessary information. If a sufficiently small amount of information is removed from a video segment, most viewers would not be aware of the change. Therefore, some of this data can be discarded. Lossy data compression techniques include transform coding. The two approaches for diffuse and symbolic data can be used together in the same compression system. For example, both transform data compression techniques and entropy coding is used in H.264 video compression.

## **Data Compression System**

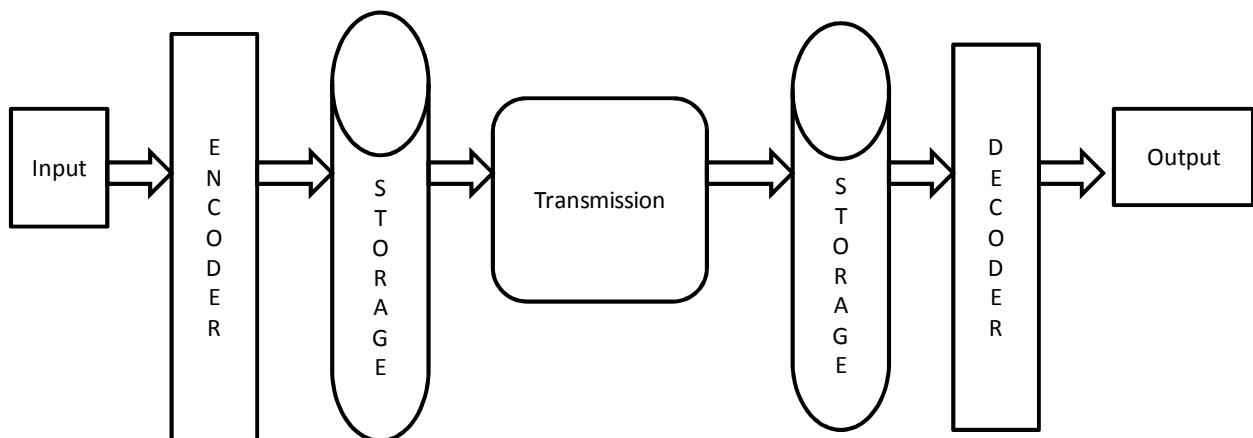
A data compression system is a combination of data compression techniques and data modeling. The two parts of the system are the encoder and the decoder. The encoder consists of input, pre-processing, modeling, and encoding. The decoder consists of modeling, decoding, and post-processing. The pre-processing transforms the data into an intermediate form that would facilitate encoding. The post-processing reverses the data from the intermediate form. The modeling gathers information about the data that will be used in encoding or decoding. An example of a compression system is shown in figure 1.

A digital system uses the data compression system to produce an output for the user: it gathers the data, encodes the data, stores the data, transmits the data, decodes

the data, and outputs the data to the end user. The decoding and encoding of this system is done by the data compression system. An example of a digital system is shown in figure 2.



**Figure 1.** Data Compression System



**Figure 2.** Digital System

## What Is This Thesis About

This thesis deals with the construction of a digital compression system for text data. This compression includes lossless compression using arithmetic coding. We



discuss the issues and approaches used to maximize the effectiveness of arithmetic coding. In particular, we address optimization by partitioning the data. Lastly, we formulate a sequential block partitioning approach that results in higher compression ratio and/or smaller average block size.

Several papers [4,8,9] have been devoted to optimizing the packet size in a communication system. This issue helps to maximize efficiency and throughput.

If the packet size is too small there are two pitfalls. In the case of a constant rate transmitter, the small packets would require more packets to be sent to keep the same bit rate. This would result in increased packets and congestion in the network. The second issue is the required overhead in these packets. Small packets would not justify the amount of overhead needed to encapsulate the packet into the header.

The case of large packet size also results in two unwanted outcomes. First, large packets tend to be discarded more frequently than smaller packets. This is due to link and transport layer error checking mechanisms that discard a packet with multiple errors. The second issue is inefficient fragmentation of the large packets. This occurs in size-constrained networks such as Ethernet where packets are fragmented into MTUs (Maximum Transfer Units) of 1500 bytes. These fragmentation operations increase bandwidth usage and additional delays.

Several procedures have been researched to find the optimum static or variable network packet size [4]. In our results, we show that we can break up a large message into significantly smaller packets with very little or no loss in compression. In [14], the notion of partitioning the file to increase compression was established. The paper left

the partition selection for future developments. In this thesis we plan to use prediction to calculate partition sizes and locations within a file.

# Chapter 1

## Information Theory

### Information

The basis for data compression is the mathematical value of information.

Information contained in a symbol  $x$  is given by,  $I(x) = \log_2 \frac{1}{p(x)}$ . This value also

describes the number of bits necessary to encode the symbol. This definition reinforces our notion of information. First, the more probable the occurrence of a symbol, the less information it provides by its occurrence, and also less bits are used to represent it.

Conversely, the least frequent symbols provide more information by their occurrence.

Secondly, if we have  $n$  equally probable messages, we know that  $\log_2 n$  bits will be required to encode each message. This is the information value of each message  $I =$

$\log_2 \frac{1}{p} = \log_2 n$ . Finally, information of two independent messages should be additive.

Consider two independent messages A and B. Here we have,

$$I(AB) = \log_2 \frac{1}{p(A)p(B)} = \log_2 \frac{1}{p(A)} + \log_2 \frac{1}{p(B)} = I(A) + I(B)$$

### Entropy

Entropy can also be defined as the measure of the average information [7].

According to Shannon, entropy of a discrete source for a finite alphabet  $X$  is given by,

$$H(x) = \sum_{x \in X} p(x) \log_2 \frac{1}{p(x)}$$

## Properties of Entropy

**Theorem 1.1.**  $0 \leq H(X) \leq \log_2 n$  where  $X = \{x_1, x_2, \dots, x_n\}$

*Proof:*

If  $p(x) = 1$  for some  $x$ , then  $H(X) = 0$ .

$$H(X) = \sum_{x \in X} p(x) \log_2 \frac{1}{p(x)} \leq \log_2 \sum_{x \in X} p(x) \frac{1}{p(x)} = \log_2 n$$

If  $p(x) = 1/n$  for all  $x$ , we have

$$H(x) = - \sum_{x \in X} \frac{1}{n} \log_2 \frac{1}{n} = - \frac{1}{n} \sum_{x \in X} \log_2 1 - \sum_{x \in X} \log_2 n = \sum_{x \in X} \frac{1}{n} \log_2 n = \log_2 n \quad [12]$$

## **Joint and Conditional Entropy**

The joint entropy  $H(X, Y)$  of two discrete random variables  $X$  and  $Y$  with joint probability distribution  $p(x, y)$  is given as,  $H(X, Y) = \sum_{x \in X} \sum_{y \in Y} p(x, y) \log_2 \frac{1}{p(x, y)} = -$

$$\sum_{x \in X} \sum_{y \in Y} p(x, y) \log_2 p(x, y)$$

The joint  $H(X, Y)$  distribution can be seen as the overall average uncertainty of the information source.

The conditional entropy  $H(X|Y)$  is the average information in  $X$  after  $Y$  has been defined or revealed. It is given as,  $H(X | Y) = \sum_{(x, y) \in (X, Y)} p(x, y) \log_2 \frac{p(y)}{p(x, y)}$

## Properties of Joint and Conditional Entropy

**Theorem 1.2.** Chain Rule:  $H(X, Y) = H(X) + H(Y|X)$

*Proof:*

$$H(X, Y) = - \sum_{x \in X} \sum_{y \in Y} p(x, y) \log_2 p(x, y) = \sum_{x \in X} \sum_{y \in Y} p(x, y) \log_2 p(x) \frac{p(x, y)}{p(x)}$$

$$\begin{aligned}
&= - \sum_{x \in X} \sum_{y \in Y} p(x)p(y|x) \log_2 p(x) + \sum_{x \in X} \sum_{y \in Y} p(x,y) \log_2 \frac{p(x)}{p(x,y)} \\
&= - \sum_{x \in X} p(x) \log_2 p(x) + H(Y|X) = H(X) + H(Y|X) \quad [12]
\end{aligned}$$

**Theorem 1.3.**  $H(X|Y) \leq H(X)$  where equality holds only if X and Y are independent

*Proof:*

$$\begin{aligned}
H(X|Y) - H(X) &= \sum_{(x,y) \in (X,Y)} p(x,y) \log_2 \frac{p(y)}{p(x,y)} - \sum_{x \in X} p(x) \log_2 \frac{1}{p(x)} \\
&= \sum_{(x,y) \in (X,Y)} p(x,y) \log_2 \frac{p(y)}{p(x,y)} - \sum_{(x,y) \in (X,Y)} p(x) \log_2 \frac{1}{p(x)} \\
&= \sum_{(x,y) \in (X,Y)} p(x,y) \log_2 \frac{p(x)p(y)}{p(x,y)} = \frac{1}{\ln 2} \sum_{(x,y) \in (X,Y)} p(x,y) \log_2 \frac{p(x)p(y)}{p(x,y)} \\
&\leq \frac{1}{\ln 2} \sum_{(x,y) \in (X,Y)} p(x,y) \left[ \frac{p(x)p(y)}{p(x,y)} - 1 \right] \\
&= \frac{1}{\ln 2} \left[ \sum_{(x,y) \in (X,Y)} p(x)p(y) - \sum_{(x,y) \in (X,Y)} p(x,y) \right] \\
&= 0 \text{ if } p(x,y) = p(x)p(y) \quad [12]
\end{aligned}$$

## Mutual Information

The mutual information  $I(X;Y)$  is the uncertainty of X that is resolved due to observing Y. It is defined by  $I(X;Y) = H(X) - H(X|Y)$

### Properties of Mutual Information

1.  $I(X;Y) = I(Y;X)$
2.  $I(X;Y) \geq 0$
3.  $I(X;Y) = H(Y) - H(Y|X)$
4.  $I(X;Y) = H(X) + H(Y) - H(X,Y)$
5.  $I(X;X) = H(X)$

The concepts of information and entropy [7] which are summarized above are basic to the development of data compression techniques. The next chapter discusses methods that use entropy explicitly.

# Chapter 2

## Entropy Coding

### Introduction

Entropy coding is compression algorithms that use the message statistics to compress the message. There are two basic approaches to entropy coding. The first approach includes the coding of individual symbols in the message alphabet. This employs the use of prefix codes. One such example is Huffman code [1]. The second type is the coding of the message or messages as a whole. This is the approach taken by Arithmetic coding [1].

### Prefix Codes

In compression we can use fixed-length codes to simplify decidability. We find that for optimal compression variable length codes yield the best results. In variable length coding the decoder has to be aware when a codeword starts and ends. In order to be able to effectively decode a message, we must be able to do this without ambiguity and without having to transfer extra decoding information. Let us suppose that we have the code  $\{(a,1),(b,00),(c,10),(d,0)\}$ . The message 100 would have multiple interpretations. It could be decoded as cd or ab. Therefore, one necessary property of coding is *unique decodability*.

Prefix code is a type of uniquely decodable code in which no codeword is a prefix for another codeword. In the context of a binary tree, each message is a leaf of the tree. This tree is referred to as the prefix-code tree[1].

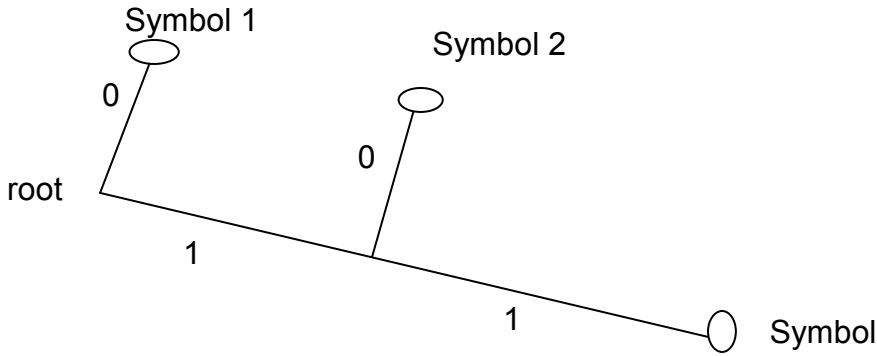


Figure 2.1. Prefix code tree. Codewords are 0,10,11.

## Kraft's Inequality

The average code length of a set of  $m$  messages is given by  $L = \sum_{i=1}^m P(x_i)n_i$

where  $n_i$  =length of symbol  $i$  in bits

**Theorem 2.1.** The codeword lengths for any uniquely decodable code must satisfy

Kraft-McMillan Inequality given as  $\sum_{i=1}^m 2^{-n_i} \leq 1$  [1]

**Theorem 2.2.** For any alphabet  $X$ , a uniquely decodable code follows  $H(X) \leq L$

Proof:

$$\begin{aligned}
 H(X) - L &= \sum_{x \in X} p(x) \log_2 \frac{1}{p(x)} - \sum_{x \in X} p(x) n_x = \sum_{x \in X} (\log_2 \frac{1}{p(x)} - n_x) = \sum_{x \in X} (\log_2 \frac{1}{p(x)} - \log_2 2^{n_x}) \\
 &= \sum_{x \in X} p(x) \log_2 (2^{-n_x} / p(x)) \\
 &\leq \log_2 (\sum_{x \in X} 2^{-n_x}) \\
 &\leq 0 \qquad \qquad \qquad [1]
 \end{aligned}$$

**Theorem 2.3.** For any alphabet  $X$ , a uniquely decodable optimal code follows

$$L \leq H(X) + 1$$

Proof:

Continued on next page



For optimality, we set  $n_x = \log_2 \frac{1}{p(x)}$

$$\begin{aligned} L &= \sum_{x \in X} p(x) n_x = \sum_{x \in X} p(x) \log \frac{1}{p(x)} \\ &\leq \sum_{x \in X} p(x) \left( 1 + \log \frac{1}{p(x)} \right) = 1 + \sum_{x \in X} p(x) \left( \log \frac{1}{p(x)} \right) = 1 + H(X) \quad [1] \end{aligned}$$

## Huffman Coding

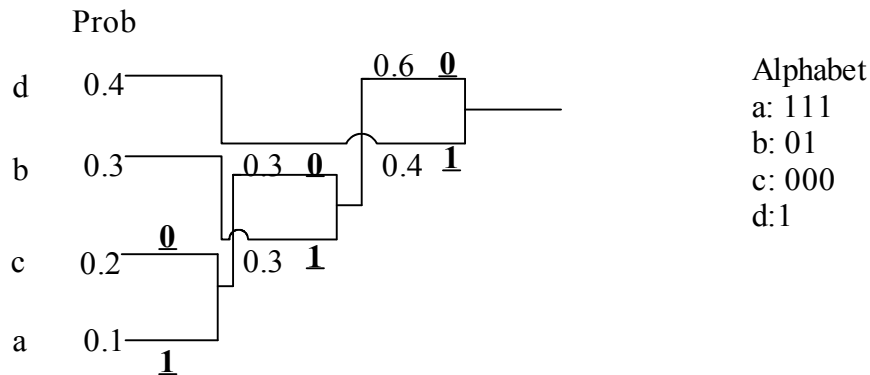
Huffman coding is the best known form of entropy coding. The premise behind Huffman coding is that more frequently occurring symbols are coded using longer code words. To accomplish this, variable length code words are assigned to symbols based on their frequency of occurrence. Huffman code satisfies two conditions:

1. All code words are uniquely decodable
2. No delimiters or extra information is inserted in the code words to facilitate decidability

The first condition is accomplished by the use of prefix code. This leads to the second condition. No markers are needed to separate the code words because of the use of prefix code.

The coding is performed using a binary tree. First, the symbols are arranged in order of decreasing probability of occurrence. Then the two least occurring symbols are combined to form a new node. The result of this node is placed in the tree in a position that preserves the order. Then the new node is combined with the next least occurring symbol to create yet another node. This process is repeated until all nodes have been processed. Afterwards a traversal back to the tree is done to tag one branch as 0 and the other as 1. Traversal from the final node back to the originating node would give you the codeword for the symbol. The final node is designated the root.

## Example 1

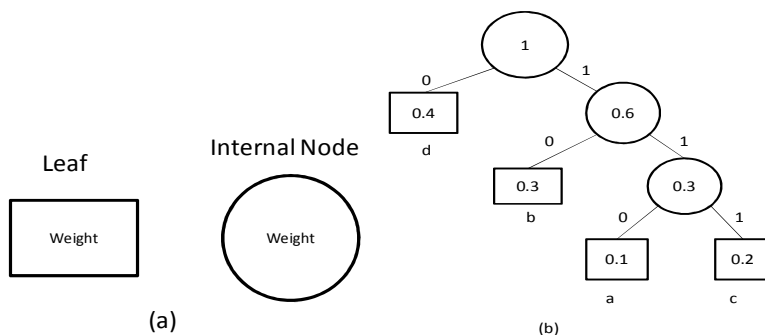


**Figure 2.2.** Huffman Code Construction. From this example the message dccb would be coded as 11000000111101.

## Alternate Implementation

A more graphical representation of Huffman coding is often used. This representation consists of leaves and internal nodes. Leaves are symbols and the internal nodes are nodes that contain the sum of the weights of its children. Whenever two leaves are combined, they form an internal node. The internal nodes in turn combine with other nodes or leaves to form more internal nodes. The leaves and nodes are ordered in increasing order from left to right.

For the input in example 1, the tree is shown in figure 2.3.



**Figure 2.3.** (a) Diagram of leaf and nodes.(b) Code tree for example 1. Alphabet: a-110,b-10,c-111,d-0

## Adaptive Huffman

Scanning of all the data is needed to provide accurate probabilities In order to perform Huffman coding. In some instances this may be an immense amount of data or the data may not be available at all. Adaptive Huffman coding schemes were created to deal with this problem,. In these schemes, the probabilities are updated as more inputs are processed. Instead of two passes through the data, only one pass is needed. One of the most famous types of adaptive Huffman algorithms is the FGK algorithm developed by Faller and Gallager. The algorithm was later improved by Cormack and Horspool with a final improvement by Knuth [7].

The sibling property is used in the FGK algorithm,. A tree follows the sibling property if every internal node besides the root has a sibling and all nodes can be numbered and arranged in nondecreasing probability order. The numbering corresponds to the order in which the nodes are combined in the algorithm. This tree has a total of  $2n-1$  nodes. Another property is lexicographical ordering. A tree is lexicographically ordered if the probabilities of the nodes at depth  $d$  are smaller than the probabilities of the nodes at depth  $d-1$ . If these two properties are employed, it will ensure that a binary prefix code tree is a Huffman tree[7].

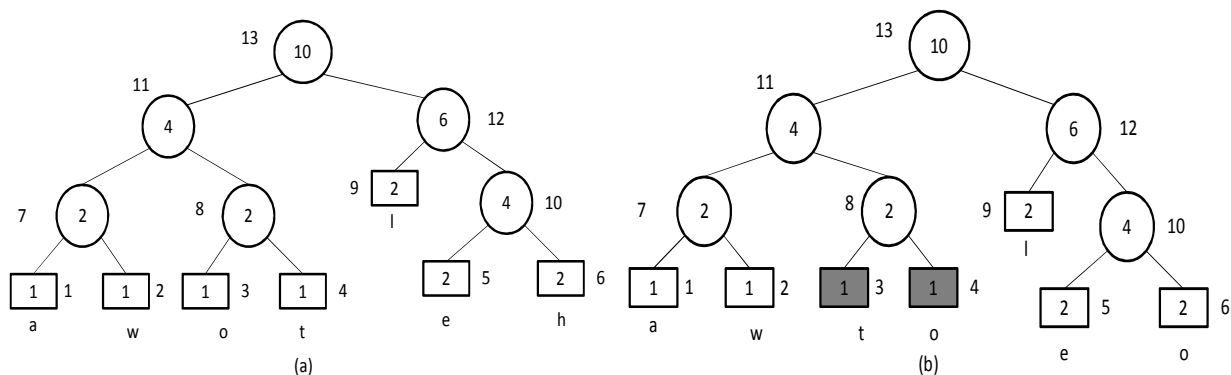
In order for the adaptive Huffman algorithm to work, two trees must be maintained. One tree is in the encoder and the other is in the decoder. Both encoder and decoder start with the same tree. When a new symbol is observed, the old symbol code is send to the decoder and its frequency in the tree is incremented. If the new incremented value causes the tree to violate the sibling property, exchange the node with the rightmost node with frequency country lower than the incremented node.

When a new value arrives, the update is carried out in two steps. The first step transforms the tree into another Huffman tree that ensures that the sibling property is maintained. The second step is incrementing of the leaves.

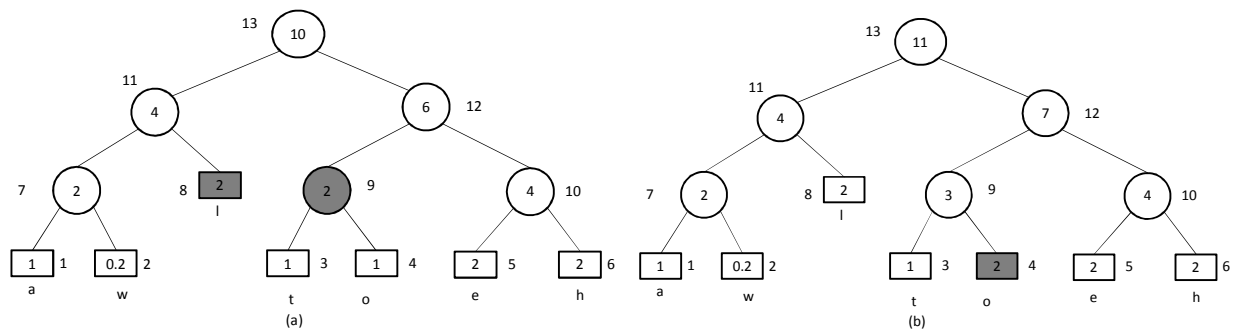
The first step starts from the leaf of the new symbol as the current node. The current node and its subtree is swapped with the highest numbered node with the same weight. The current node becomes the swapped node. Then we move to the swapped node's parent. The same swap is repeated here. This step repeats until the root is reached.

### Example 2.2

Consider the dynamically created tree in figure 2.4. Notice that if we get a new input of "o" and increment the leaf immediately, the tree would no longer satisfy the sibling property. Therefore, the tree must be updated before incrementing the "o" node. The current node starts with "o" or node 3. First, node 3 and 4 are swapped. The current node becomes 8. Then, node 8 and 9 are swapped. The current node becomes node 12. It does not find any matching nodes, so the next node becomes node 13. The updating of the tree ends and node 3 is incremented. The final tree satisfies the sibling property.



**Figure 2.4.** (a)Initial tree before "o" is observed (b) "o" is swapped with "t"



**Figure 2.5.** Continuation of Figure 2.4. (a) Node 8 is swapped with 9 (b) the “o” is incremented.

Vitter’s algorithm  $\Lambda$  [15] further optimizes the FGK algorithm. In the original FGK algorithm, it was sufficient for the nodes of a given depth to increase in probability from left to right. In Vitter’s algorithm all leaves must precede the internal nodes of the same probability and depth. This change ensures that the dynamic algorithm encodes a message of length  $s$  bits with less than  $s$  bits more than with the static Huffman. The algorithm minimizes  $\sum w_j l_j$ ,  $\max l_j$ , and  $\sum l_j$ . To accomplish this Vitter used implicit numbering. Nodes were numbered in non-decreasing probability order from left to right and top to bottom.

## Arithmetic Coding

Unlike other types of compression, in Arithmetic coding a sequence of  $n$  symbols is represented by a number between 0 and 1. Arithmetic coding came from Shannon’s observation that sequences of symbols can be coded by their cumulative probability.

## Advantages of Arithmetic Coding

The first advantage of Arithmetic coding is its ability to keep the coding and the modeler separate. This is its main difference from Huffman coding. This change also makes adaptive coding easier because changes in symbol probabilities do not affect

the coder. Unlike Huffman coding, no code tree needs to be transmitted to the receiver. Encoding is done to a group of symbols not symbol by symbol. This leads to higher compression ratios. The final advantage of Arithmetic coding is its use of fractional values. In Huffman coding is that there is code waste. It is only optimal for coding symbols with probabilities that are negative powers of 2. Huffman coding will rarely reach optimality in real data because  $H(s)$  will never be an integer. Therefore, for an alphabet with entropy  $H(s)$ , Huffman will use up to 1 unnecessary bit.

## **Disadvantages of Arithmetic Coding**

The first disadvantage of Arithmetic coding is its complex operations. Arithmetic coding consists of many additions, subtractions, multiplications, and divisions. It is difficult to create efficient implementations for Arithmetic coding. These operations make Arithmetic coding significantly slower than Huffman coding. The final disadvantage of Arithmetic coding is referred to as the precision problem [11]. Arithmetic coding operates by partitioning interval  $[0,1)$  into infinitively smaller and smaller intervals. There are two issues in implementation: there are no infinite precision structures to store the numbers and the constant division of interval may result in code overlap. There are many implementations that address these issues.

The main aim of Arithmetic coding is to assign an interval to each potential symbol. Then a decimal number is assigned to this interval. The algorithm starts from the interval  $[0, 1)$ . After each read input, the interval is subdivided into a smaller interval in proportion to the input symbol's probability. The symbols in the alphabet are scaled into the new alphabet.

In order to perform the interval reshaping needed for coding cumulative distributions are needed to keep upper and the lower bound values for the code intervals. Each rescaling will be based on the current symbol's range of cumulative probability. Therefore, each symbol's rescaling will be different.

For a symbol  $s_k$ , we have the cumulative probability  $C(s_k) = \sum_{i=1}^k P(s_i)$  where  $P(s_i)$ =probability of symbol  $s_i$ .

Low bound for symbol  $s_k = \sum_{i=1}^{k-1} P(s_i) = C(a_{k-1})$

High bound for symbol  $s_k = \sum_{i=1}^k P(s_i) = C(a_{k-1}) + P(s_k) = C(a_k)$

The low and high values are initially set to 0 and 1 respectively. Whenever a new symbol  $s_j$  is received, the low and the high are updated as follows:

range=high-low

Low=low +  $\sum_{i=1}^{j-1} P(s_i) * (high - low) = low + C(a_{j-1}) * range$

High=low +  $\sum_{i=1}^j P(s_i) * (high - low) = low + C(a_j) * range$

The process runs recursively for all symbols in the input sequence. The final code value will be between the high and low values.

The decoder is similar to the encoder. The low and high are initially set to 0 and 1. Suppose we have the received code  $C$ . Suppose this value falls within symbol  $k$ 's low and upper bound value. Symbol  $k$ 's values are used to ensure that  $low \leq C \leq high$  values. The range low becomes  $C(a_{k-1})$  and high becomes  $C(a_k)$

For all symbols:

Low=low +  $\sum_{i=1}^{k-1} P(s_i) * (high - low) = low + C(a_{k-1}) * range$

High=low +  $\sum_{i=1}^k P(s_i) * (high - low) = low + C(a_k) * range$

The next symbol  $k$  is such that  $Low \leq Low + C(a_{k-1}) * range$  and  $Low + C(a_k) * range \leq High$

## Example 2.3

**Table 2.1** Symbol statistics

Symbol	Probability	Cumulative Distribution	low	high
A	0.4	0.4	0	0.4
B	0.4	0.8	0.4	0.8
L	0.2	1.0	0.8	1.0

### Encoding

Sequence BALL

Encode 'B':  $\text{low}=0+0.4*1=0.4$

$\text{high}=0+0.8*1=0.8$

Encode 'A':  $\text{low}=0.4+(0)*(0.4)=0.4$

$\text{high}=0.4+(0.4)(0.4)=0.56$

Encode 'L':  $\text{low}=0.4+(0.8)*(0.16)=0.528$

$\text{high}=0.4+(1.0)(0.16)=0.56$

Encode 'L':  $\text{low}=0.528+(0.8)*(0.032)=0.5536$

$\text{high}=0.528+(1.0)(0.032)=0.56$

### Decoding

Suppose code is 0.79

Decode 'B'

$\text{Low}=0+0.4=0.4$

$\text{high}=0+0.8=0.8$

$\text{Low}=0.4+0*(0.8-0.4)=0.4$

$\text{high}=0.4+(0.4)(0.4)=0.56 \Rightarrow \text{Decode 'A'}$

$\text{Low}=0.4+0.8*(0.56-0.4)=0.528$

$\text{high}=0.4+(1.0)(0.16)=0.56 \Rightarrow \text{Decode 'L'}$

$\text{Low}=0.528+0.8*(0.56-0.528)=0.5536$

$\text{high}=0.528+(1.0)(0.032)=0.56 \Rightarrow \text{Decode 'L'}$

## Optimality of Arithmetic Coding

From the decoding algorithm, we can see that as the interval is divided, the number of binary sequence also doubles. Therefore we can say that for an arbitrary code range,  $I_N$ , the minimum encoding length,  $L_{\min} = -\log_2(I_N)$  bits.



For an encoding sequence S, the number of bits per symbol is bounded by:  $L_S \leq$

$$\frac{\sigma - \log_2(l_N)}{N} \text{ bits / symbol } \Omega \quad \text{where } \sigma \text{ is the total compression overhead including bits}$$

required for saving the file, bits representing number of symbols, and information about

the probabilities. Given that  $l_N = \prod_{k=1}^N p(s_k)$ , we get  $L_S \leq \frac{\sigma - \sum_{k=1}^N \log_2 p(s_k)}{N} \text{ bits / symbol}$

The expected number of bits per symbol is

$$\bar{L} = E[L_S] \leq \frac{\sigma - \sum_{k=1}^N E[\log_2 p(s_k)]}{N} = \frac{\sigma - \sum_{k=1}^N \sum_{m=0}^{M-1} p(m) [\log_2 p(m)]}{N} \leq H(\Omega) + \frac{\sigma}{N}$$

The average number of bits is bounded by the entropy.

$$H(\Omega) \leq \bar{L} \leq H(\Omega) + \frac{\sigma}{N}$$

Therefore, as  $N \rightarrow \infty$ , the average number of bits approaches entropy. We can see that Arithmetic coding achieves optimal performance.

## Adaptive Arithmetic Coding

As with Adaptive Huffman, Adaptive Arithmetic coding also reduces the number of passes through the data from two to one. The difference between the two is that there is no need to keep a tree for the codewords. The only information that needs to be synchronized is the frequency of occurrence of the symbols.

### Example 2.4

For this example, we will rework example 2.3. Unlike the previous example, the statistics table will be updated as symbols are encoded. The symbols are also updated when symbols are decoded.

**Table 2.2.** Initial table

symbol	frequency	probability	low	high
A	4	0.4	0	0.4
B	4	0.4	0.4	0.8
L	2	0.2	0.8	1

Encode 'B':  $\text{low}=0+0.4*1=0.4$

$\text{high}=0+0.8*1=0.8$

**Table 2.3.** Table after 'B' is encoded

symbol	frequency	probability	low	high
A	5	4/11	0	4/11
B	4	5/11	4/11	9/11
L	2	2/11	9/11	1

Encode 'A':  $\text{low}=0.4+(0)*(0.4)=0.4$

$\text{high}=0.4+(0.4)(4/11)=6/11$

**Table 2.4.** Table after 'A' is encoded

symbol	frequency	probability	low	high
A	5	5/12	0	5/12
B	5	5/12	5/12	10/12
L	2	2/12	10/12	1

Encode 'L':  $\text{low}=0.4+(8/55)*(10/12)=86/165$

$\text{high}=0.4+(1.0)(8/55)=0.56$

**Table 2.5.** Table after 'L' is encoded

symbol	frequency	probability	low	high
A	5	5/13	0	5/13
B	5	5/13	5/13	10/13
L	2	3/13	10/13	1

Encode 'L':  $\text{low}=(86/165)+(10/13)*(44/1815)=0.53986$

$\text{high}=(86/165)+(1)(44/1815)=0.54545$

Decoding

Input=0.54 Decode 'B'

$\text{low}=0+0.4*1=0.4$

$\text{high}=0+0.8*1=0.8$

**Table 2.6.** Table after 'B' is decoded

symbol	frequency	probability	low	high
A	5	4/11	0	4/11
B	4	5/11	4/11	9/11
L	2	2/11	9/11	1

$$\text{low}=0.4+(0)*(0.4)=0.4$$

$$\text{high}=0.4+(0.4)(4/11)=6/11$$

Decode 'A'

**Table 2.7.** Table after 'B' is encoded

symbol	frequency	probability	low	high
A	5	5/12	0	5/12
B	5	5/12	5/12	10/12
L	2	2/12	10/12	1

$$\text{low}=0.4+(8/55)*(10/12)=86/165$$

$$\text{high}=0.4+(1.0)(8/55)=0.56$$

Decode 'L'

**Table 2.8.** Table after 'L' is decoded

symbol	frequency	probability	low	high
A	5	5/13	0	5/13
B	5	5/13	5/13	10/13
L	2	3/13	10/13	1

$$\text{low}=(86/165)+(10/13)*(44/1815)=0.53986$$

$$\text{high}=(86/165)+(1.0)(44/1815)=0.54545$$

Decode 'L'

## **Chapter 3**

### **Data Modeling**

#### **Introduction**

Data sources hold certain characteristics that enables for better compression of the data. For example, consider the statement “Raving mount”. If we were examining an English text input, there is low probability that the next phrase would be “red suit”. The modeling of the behavior or characteristics of data enables the compression system to further compress the data. It would be improbable for one to code a computer to recognize all possible combinations of phrases. Therefore, we must create a model describing the structure rather than a phrase dictionary.

In order to examine a model for data, we need to examine the information we currently hold about it. This includes what we know about the data’s structure and composition, its worst case scenario for compression, and its best case scenario for compression.

#### **What Do We Know About the Data**

The first step is defining our basic knowledge of the data. For example, in text data we know that the alphabet consists of the ASCII symbols. If we were to get more specific, we can define language. Language lets us know about frequencies of words and letters. For example, Latin languages have more words that start with vowels than Germanic languages.

## **Worst Case Scenario**

In defining the bounds of the data, it would be helpful to know what would be the worst conditions that would deter compression. This case involves high uncertainty and complexity in the data. The data in these types of sources have low symbol repetition. In entropy coding, this is characterized by high source entropy.

## **Best Case Scenario**

The best case scenario is the case where we get the highest compression ratio. This case involves highly predictable data. A data sequence with highly repetitive data would be characteristic of these sources. This is characterized by low entropy value in entropy coding.

## **Application to Compression**

In entropy coding, the statistics of the source data is used in the data compression. In dictionary algorithms, a table of known words is used in compression of the data. In video compression there is temporal, spatial, and color space redundancy in the data.

Another important application of data modeling is in prediction. One can predict future behavior based on present data or past data. In this paper, we will use this prediction behavior to predict the information content of future data.

## **Sources**

We need to formulate a mathematical model that describes the data in question from an information source. In the beginning of the chapter we discussed the entropy model. This model was based on Shannon's measure of information. Though helpful in

describing the data, it does not fully characterize the relationship between the data elements in the source. Here we describe the Markov model.

## Markov Models

In his famous paper [13] Shannon proposed a statistical structure in which finite symbols in the alphabet depend on the preceding symbol and nothing else. This type of process is known as a Markov chain.

**Definition:** A stochastic process  $\{X_n:n=0,1,\dots\}$  with a finite alphabet  $S$  is a Markov chain, if for any  $a,b \in S$

$$P(X_{n+1}=b|X_n=a,X_{n-1}=a_{n-1},\dots,X_0=a_0)=P(X_{n+1}=j|X_n=i) \quad [13]$$

The process is then described using a set of transition probabilities  $p_{ij}=P(X_{n+1}=j|X_n=i)$ .

These denote the probability of symbol  $i$  being followed by symbol  $j$ . The probability transition matrix for 1<sup>st</sup> order transitions probabilities

$$P_{ij} = \begin{bmatrix} p_{11} & p_{12} & \dots & p_{1s} \\ p_{21} & p_{22} & \dots & p_{2s} \\ \vdots & \vdots & \ddots & \vdots \\ p_{s1} & p_{s2} & \dots & p_{ss} \end{bmatrix}$$

This would be sufficient if we were dealing with transitions between two symbols. For instance, in language we know that often the length of words is two or more letters. We can reach more words and get a better approximation if our model can reach longer length of transitions. We can put this in terms  $P_{ikj}$ , which is the probability of a letter  $i$  being followed by some  $k$ , which in turn is followed by  $j$ . This probability is given by:

$$P_{ikj} = \sum_{k=0}^{\infty} P_{ik} P_{kj} \quad [13]$$

Shannon devised source models and showed how they approach language.

General types of approximations as described by Shannon:

1. Zero-order: Symbols are independent and equally probable

Example: XFOML RXKHRJFFJUJ ZLPWCFCWKCYJ FFJEYVKCQSGHYD  
QPAAMKBZAACIBZLHJQD

2. First-order: Symbols independent but with frequencies of English text

Example: OCRO HLI RGWR NMIELWIS EU LL NBNESBYA TH EEI  
ALHENHTTPA OOBTTVA NAH BRL

3. Second-order: digram as in English(second order markov model)

Example: ON IE ANTSOUTINYS ARE T INCTORE ST BE S DEAMY ACHIN D  
ILONASIVE TUCOOWE AT TEASONARE FUSO TIZIN ANDY TOBE SEACE  
CTISBE

4. Third-order: trigram as in English

Example: IN NO IST LAT WHEY CRATICT FROURE BIRS GROCID  
PONDENOME OF DEMONSTRURES OF THE REPTAGIN IS REGOACTIONA  
OF CRE

5. First-order word: words independent with frequencies of English text

Example: REPRESENTING AND SPEEDILITY IS AN GOOD APT OR COME  
CAN DIFFERENT NATURAL HE THE A IN CAME THE TO OF TO EXPERT  
GRAY COME TO FURNISHES THE LINE MESSAGE HAD BE THESE.

6. Second-order word: word transition probabilities used

Example: THE HEAD AND IN FRONTAL ATTACK ON A ENGLISH WRITER  
THAT THE CHARACTER OF THIS POINT IS THEREFORE ANOTHER  
METHOD FOR THE LETTERS THAT THE TIME OF WHO EVER TOLD THE  
PROBLEM FOR AN UNEXPECTED.

## Models in Compression

There are two types of modeling, static and dynamic. In static modeling, there are preset values that describe the data in question. Examples would be dictionaries used in dictionary compression and probabilities in entropy coding. Dynamic modeling is done as the data is processed. In this section we explore dynamic modeling and how it will be exploited to optimize Arithmetic coding.

In communication, partitioning of data has many useful advantages. It enables easier decoding, it helps in minimizing burst errors, and it preserves channel bandwidth.

**Theorem 3.1.** For any data there can be a partition of size smaller than or equal to the size of the data to be processed that if employed can yield code smaller than if the total data was coded.

This is usually the case in data that contains blocks of entropy much smaller than the total file. Let us look at some examples.

This is usually the case in data that contains blocks of entropy much smaller than the total file. Let us look at some examples.

### Example 3.1

A simple example would be the data sequence “aaaacabc”. Using optimal coding we get 11 bits for the message (one bit for each “a” and two bits for each b and c).

If we code the first part “aaaaca” then the second part “bc”, we get six bits for the first part (one bit for each “a” and one bit for each c) and two bits for the second part (one bit for each “b” or “c”). It takes a total of eight bits to code these two sequences. Breaking the total sequence into two parts saves three bits.



### Example 3.2

Let us look at the sequence “aaaabbbbccccdddd”.

Coding the entire sequence, we get 32 bits (two bits to code each letter). If we break the file into 4 sequences (aaaa,bbbb,cccc,dddd), we get only 4 bits for each sequence (one bit for each letter). Here we save 16 bits.

These are small examples, but they highlight our point. If we could recognize when partitioning the data would help data compression, this would be a useful tool when dealing with large files.

To employ partitioning in a dynamic compression algorithm, the received input data has to be analyzed, then the algorithm has to predict if the coding of this portion of data will yield higher compression than the data combined with the rest of the file. In order for this prediction to be valid, future values of the data must also be predicted. This is possible through the use of the entropy and Markov models.

## **Adaptive Arithmetic Compression Using Data Models**

Adaptive Arithmetic coding is most effective on large files. Since we are dealing with extremely large files, obviously, the amount of data coded before a new value arrives can also be large. We content that, by using theorem 3.1, we can partition this portion of data without risking loss of compression ratio. In order for this method to be effective, all symbol probabilities for a segment must be cleared after each data is sent. Furthermore, instead of beginning each coding segment with an empty symbol list, we will initialize all symbols with 1 occurrence. This will keep the program from multiple transmissions of unobserved symbols for each code block.

## Partition Conditions

**Theorem 3.2.** A sequence within a file of  $n$  characters with entropy  $H_1$  can be partitioned into its own code if it satisfies:

$$nH_1 + (N - n)H_{2,approx} \leq NH_{approx,total}$$

**Theorem 3.3.** Assuming the worst case where rest of the sequence,  $H_{2,approx}$ , has equally probable symbol distributions, the above condition may be restated as:

$$nH_1 + (N - n) \sum_{i=1}^{N-n} \frac{1}{N-n} \log_2(N-n) \leq NH_{approx,total}$$

This simplifies to

$$nH_1 + (N - n)\log_2(N - n) \leq NH_{approx,total}$$

$$nH_1 \leq NH_{approx,total} - (N - n)\log_2(N - n)$$

where  $N$  is the size of the total data sequence to be coded, and  $H_{approx,total}$  is the approximate total entropy if the data was coded together.

**Theorem 3.4.** Theorem 3 is a strong condition of theorem 3.2, in that if it holds theorem 3.2 also holds.

Proof: Let us examine an arbitrary  $H_2$  that satisfies theorem 3.2.

$$nH_1 + (N - n)H_2 \leq NH_{approx,total}$$

We know that  $NH_{approx,total} - (N - n)\log_2(N - n) \leq NH_{approx,total} - (N - n)H_2$

Therefore if  $nH_1 \leq NH_{approx,total} - (N - n)\log_2(N - n)$  then  $nH_1 \leq NH_{approx,total} - (N - n)H_2$

We chose to use the strong condition here to compensate for the coding loss due to repeated transfer of probability data after each coding. The condition had to be sufficient to justify the premature coding.

In order for the test to be effective, the data sequence has to be significantly large. If the data sequence is significantly smaller than the total sequence, then  $(N)\log_2(N) \approx H_{\text{approx, total}}$  for the test to pass. This situation would never happen because the expression  $(N)\log_2(N)$  is the upper bound value.

Additionally, we must limit the amount of times the test is administered. If the test does not pass for  $n$ , it is a very low possibility that it will pass for  $n+1$ . Therefore, if the tests are significantly spaced apart, unnecessary tests will be avoided.

### Approximation of Symbol Statistics

To approximate the total entropy of the sequence of data, we need to employ the models discussed earlier. These are entropy and Markov model.

#### Entropy Model

The entropy model is the simplest. It does not require prediction of symbol occurrences. The only measure is the total entropy values. Taking into account, the previous statistical information, we can predict the future statistics. In this case, we will use previously calculated statistics to calculate entropy. This would require a language based entropy value.

#### Markov Model

Markov model will involve the generation of approximate data using 1<sup>st</sup> order Markov model. The sequence data would start with the data with the highest frequency and move from symbol to symbol based on symbol transition probabilities. Like the entropy model, the static Markov modeling would get its transition probabilities from a language based table. In the dynamic modeling, the transition probabilities would come from the data being compressed.

To generate the characters, we first recreate the probability matrix so that it becomes a frequency matrix.

$$F_{ij} = \begin{bmatrix} f_{11} & f_{12} & \cdots & f_{1s} \\ f_{21} & \vdots & & \vdots \\ \vdots & & & \vdots \\ f_{s1} & f_{s1} & \cdots & f_{ss} \end{bmatrix}$$

First, we start from the first symbol. We then find the highest frequency symbol. Then the location in the matrix of the corresponding symbol is decremented. The symbol becomes the current state. The process is repeated until N-n symbols have been generated. Therefore as N-n goes to infinity the entropy of the generated sequence will approach the upper bound.

**Theorem 3.5.** No symbol will experience starvation, a state in which it will never be visited even though it is reachable from any other symbols(s).

Proof: Let us assume that a state k is only reachable from state r. If the lowest frequency transition of any symbol greater than k is  $f_{k+1}$ , then after  $f_{k+1}$  passes through the symbol r,  $f_k$  becomes the highest frequency. Therefore, state r will be visited.

## Chapter 4

# Implementation of Arithmetic Coder

## Introduction

The implementation was done using only integer arithmetic. It helped in simplicity and speed. At the heart of the basic Arithmetic coder is the rescaling of the intervals. In our implementation, we use scaling techniques employed by Bodden, Clasen, and Kneis [2]. The coder is broken up into three sections: modeler, encoder, and decoder.

## Modeler

Since the model is dynamic, symbol frequencies must be updated after each symbol is observed. All the values used in the implementation are integers; therefore, the frequencies instead of probabilities were kept. The properties of each symbol are frequency, frequency lower bound, frequency upper bound, and cumulative frequency. The modeler has also contains the global property of total frequency. As mentioned earlier, all the values are integers. The total frequency and the symbol frequency will be used to calculate the symbol probabilities. These probabilities will be used in the rescaling mentioned in chapter three.

**Algorithm 4.1.** Operation to update the symbol statistics

---

```
Model_Update(new_symbol)
    Increment freq[symbol]
    Increment total_freq
    For all symbols i until new_symbol
        Set low_Freq[i]=cum_Freq[i-1]
        Set cum_Freq[i]=low_Freq[i]
        Set high_Freq[i]=cum_Freq[i]+freq[i]
```

---

## Encoder

In the implementation 32 bits were used. The initial low value is zero, and the initial high value is 0x7FFFFFFF. The 32th bit was used to store overflows after addition operations. We add one to the range because High represents the open upper bound value. The real interval is larger by one. We also subtracted one from the new High value should be lower than low of next subinterval. We also normalize the cumulative frequencies into the cumulative probabilities by dividing them by the total frequencies.

### Algorithm 4.2 Operation to encode a file

---

#### *Encoder(file)*

*Start with LOW=0 and HIGH=0x7FFFFFFF*

*Until end of file*

*Get symbol*

*RANGE = HIGH – LOW + 1*

*HIGH = HIGH +( RANGE \* Cum\_Freq[ symbol ] / total\_freq )- 1*

*LOW = LOW + RANGE \* Cum\_Freq[ symbol-1] / total\_freq*

*Encoder\_Scale()*

*Model\_Update(symbol)*

---

The values of low and high will inevitably converge. Scaling will need to be done to keep this from happening. This will also allow infinite precision in our coding using finite precision integers. There are 3 types of scaling: E1, E2, and E3 [2].

## E1 and E2 Scaling

Converging happens when either the low value is in the top half of the range or the high value is in the bottom half of the range. We know that once this happens, the values will never leave this range. Therefore, we can send the most significant bits of the low and high values to the output and shift the low and high values. E1 scaling deals with the situation when the high value is in the bottom half. E2 scaling deals with the situation when the low value is in the top half. Both of the scaling is performed by

doubling the range and shifting. We output a zero if E1 is performed and a one if E2 is performed.

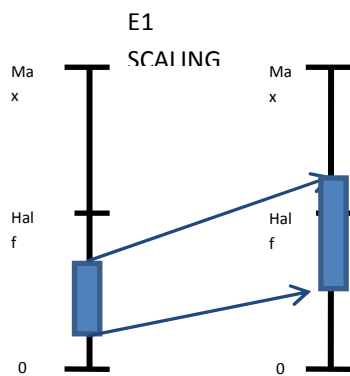
### E1 Scaling

$$\text{High} = 2 * \text{High} + 1$$

$$\text{Low} = 2 * \text{Low}$$

High=0xxxxx... becomes xxxxx1

Low=0xxxx... becomes xxxxxx0



**Figure 4.1.** E1 Scaling

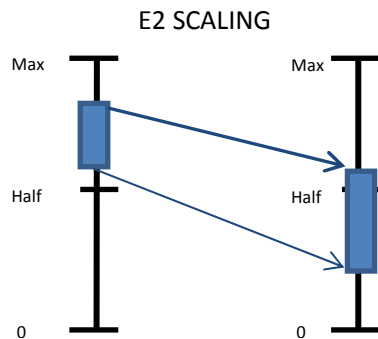
### E2 Scaling

$$\text{High} = 2 * (\text{High} - \text{Half}) + 1$$

$$\text{Low} = 2 * (\text{Low} - \text{Half})$$

High=1xxxxx... becomes xxxxx1

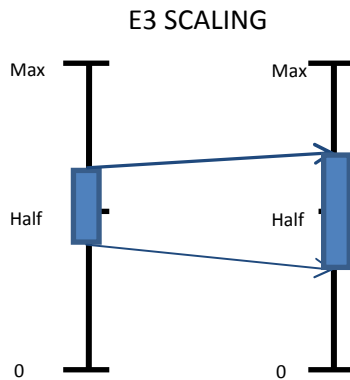
Low=1xxxx... becomes xxxxxx0



**Figure 4.2.** E2 Scaling

## E3 Scaling

E3 scaling deals with situations where low and high are small values around the halfway point that cannot be represented with our available precision. In this case, E1 and E2 do not apply.



**Figure 4.3.** E3 Scaling

Quarter =  $2^{m-2}$  for m-bit integer

High = (High-Quarter)\*2+1

Low = (Low-Quarter)\*2

Low = 01xxxxx becomes 0xxxxxx0

High = 10xxxxx becomes 1xxxxxx1

Once E3 Scaling is done, we still will not know which half will contain the result. This will only be apparent in the next E1 or E2 scaling. Therefore, instead of outputting a bit, we store the number of E3 scalings and output the corresponding bits in the next E1 or E2 scaling. We can output the signal for the E3 scalings in the E1 and E2 scalings this is because of the theorem below.

**Theorem 4.1.** Given the notation  $E_i \circ (E_j)^n$ : n  $E_j$  scalings followed by an  $E_i$  scaling

We have:  $E_1 \circ (E_3)^n = (E_2)^n \circ E_1$  and  $E_2 \circ (E_3)^n = (E_1)^n \circ E_2$

Proof: Continued on next page



We know that for the interval [a,b)

$$E_1[a, b) = [2a, 2b) \quad (E_1)^n[a, b) = [2^n a, 2^n b)$$

$$E_2[a, b) = [2a - 1, 2b - 1) \quad (E_1)^n[a, b) = [2^n a - 2^n + 1, 2^n b - 2^n + 1)$$

$$E_3[a, b) = \left[2a - \frac{1}{2}, 2b - \frac{1}{2}\right) \quad (E_1)^n[a, b) = \left[2^n a - 2^{n-1} + \frac{1}{2}, 2^n b - 2^{n-1} + \frac{1}{2}\right)$$

Therefore,

$$\begin{aligned} E_1 \circ (E_1)^n[a, b) &= E_1 \left[2^n a - 2^{n-1} + \frac{1}{2}, 2^n b - 2^{n-1} + \frac{1}{2}\right) \\ &= [2^{n+1} a - 2^n + 1, 2^{n+1} b - 2^n + 1) \end{aligned}$$

$$(E_2)^n \circ E_1[a, b) = (E_2)^n[2a, 2b) = [2^{n+1} a - 2^n + 1, 2^{n+1} b - 2^n + 1)$$

Similarly,

$$E_2 \circ (E_3)^n[a, b) = E_2 \left[2^n a - 2^{n-1} + \frac{1}{2}, 2^n b - 2^{n-1} + \frac{1}{2}\right) = [2^{n+1} a - 2^n, 2^{n+1} b - 2^n)$$

$$(E_1)^n \circ E_2[a, b) = (E_1)^n[2a - 1, 2b - 1) = [2^{n+1} a - 2^n, 2^{n+1} b - 2^n)$$

To terminate the encoding, we have to tell the decoder the location of the final interval and handle any remaining E3 scalings. In the end, we have two scenarios for our interval:  $Low < Quarter < Half \leq High$  and  $Low < Half < Half + Quarter \leq High$ .

To tell the encoder that the final interval is the first scenario we simply send a 01 and output 1's depending on the number of remaining E3 scalings. For the second scenario we send a 1. We also would send zeros based on E3 scalings.

**Algorithm 4.3.** Operation to output the bits and rescale the intervals

---

**Encoder\_Scale()**

```

While E1, E2, or E3 scaling is possible
  If E3(Low > Quarter and high < Half + Quarter)
    High = (High - Quarter) * 2 + 1;
    Low = (Low - Quarter) * 2
    E3_Scalings = E3_Scalings + 1
  If E1(High < Half) or E2(Low > Half)
    Output 0 for E1 and 1 for E2

```

Continue on next page

$High = High * 2 + 1$   
 $Low = Low * 2$   
 For all  $E3\_Scalings$   
 Output 1 if  $E1$  or 0 if  $E2$

---

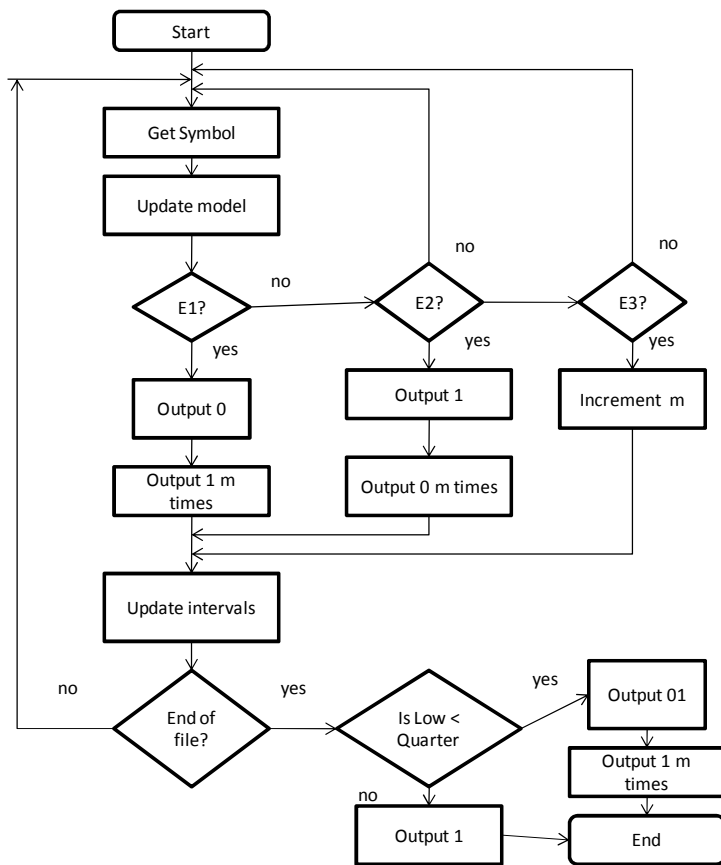
**Algorithm 4.4.** Operation to properly terminate the encoding

**Encoder\_Termination()**

```

If (low < Quarter)
    Output 01
    For all E1 scalings
        Output 1
Else
    Output 1
    
```

---



**Figure 4.4.** Encoding Flowchart

## Decoder

The decoder basically reverses the process from the encoder. The decoder starts by reading the first 31 bits of the output. This is used as a target to get the code

values. The code value is used to find the symbol according to symbol low and high cumulative frequencies. The target is updated using the decoder scalings. For each scaling, a new bit is shifted into the target. The operation continues until all symbols have been outputted.

---

**Algorithm 4.5.** Operation to decode a file

---

**Decoder(file)**

```

LOW=0
HIGH=0x7FFFFFFF
Get target from file
Until end of file
    RANGE=HIGH-LOW+1
    Code=(target-LOW)/(Range/total_freq)
    Symbol=FindSymbol(Code)
    Output symbol
    HIGH = HIGH +( RANGE * Cum_Freq[ symbol ] / total_freq )- 1
    LOW = LOW + RANGE * Cum_Freq[ symbol-1]/ total_freq
    Target=Decoder_Scale(target)
    Model_Update(symbol)

```

---



---

**Algorithm 4.6.** Operation to find a symbol base on a code target

---

**FindSymbol(target)**

```

For all symbols j
    If(low_freq[j]<=target and high_freq[j]>target)
        symbol=j
    output symbol

```

---



---

**Algorithm 4.7.** Operation to rescale the intervals and get bits from the file

---

**Decoder\_Scale(target)**

```

While E1, E2, or E3 scaling is possible
    If E3(low>Quarter and high<Half+Quarter)
        High=(High-Quarter)*2+1;
        Low=(Low-Quarter)*2
        Target=target*2
        Target=target+Get_Bit()
    If E1(High<Half) or E2(Low>Half)
        High=High*2+1
        Low=Low*2
        Target=target*2
        Target=target+Get_Bit()
Output target

```

---

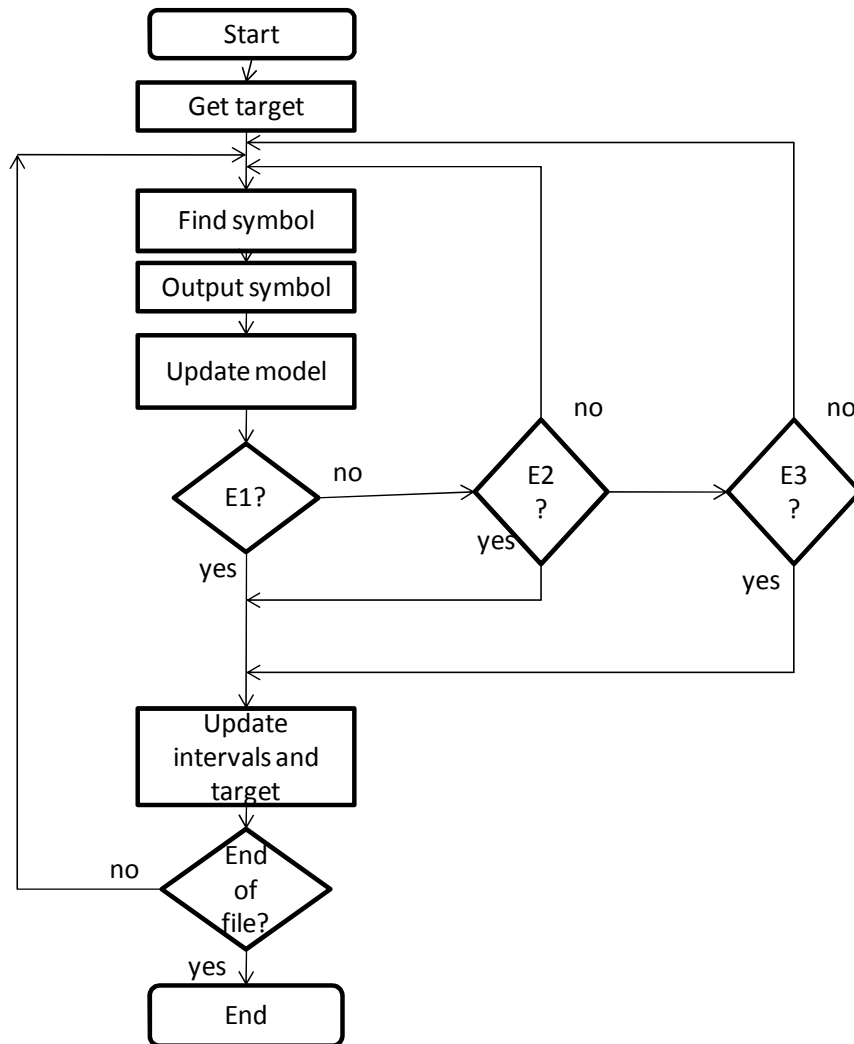


Figure 4.5. Decoding flowchart

## Modified Arithmetic Coder

For the second implementation of the coder, predictive compression was used. Instead of coding the entire message, the message was broken up into blocks. A function was created to calculate these blocks. The model changes because now we have to keep track of the transition frequencies. The transition probabilities are used to predict the entropy value of the remaining file. The entropy is used predict the final compression.

## Modeler

The modeler is updated to keep the symbol transition frequencies. Whenever a new symbol is observed, the transition frequency from the previous symbol to the current symbol is updated. The entropy of the alphabet is also kept. The rest of the values remain the same.

---

### Algorithm 4.8. Operation to update symbol statistics and transitions

---

```
Model_Update(new_symbol,previous_symbol)
  Increment transition(previous_symbol,new_symbol)
  Increment freq[symbol]
  Increment total_freq
  For all symbols i until new_symbol
    Set low_Freq[i]=cum_Freq[i-1]
    Set cum_Freq[i]=low_Freq[i]
    Set high_Freq[i]=cum_Freq[i]+freq[i]
```

---

---

### Algorithm 4.9. Operation to calculate model entropy

---

```
Entropy(model)
  Total=0
  For all symbols i
    Total=total+freq[i]
  Entropy=Total/total_freq
```

---

## Encoder

Encoder keeps two models, global and local. The global model is kept throughout the entire file. The local model is restarted whenever a block of data is coded.

---

### Algorithm 4.10. Operation to encode a file

---

```
Encoder(file)
  Start with LOW=0 and HIGH=0x7FFFFFFF
  Until end of file
    Get symbol
    RANGE = high_Freq[symbol] – low_Freq_Local[symbol] + 1
    HIGH = HIGH +( RANGE * Cum_Freq_Local[ symbol ] / total_steps )- 1
```

*Continued on next page*

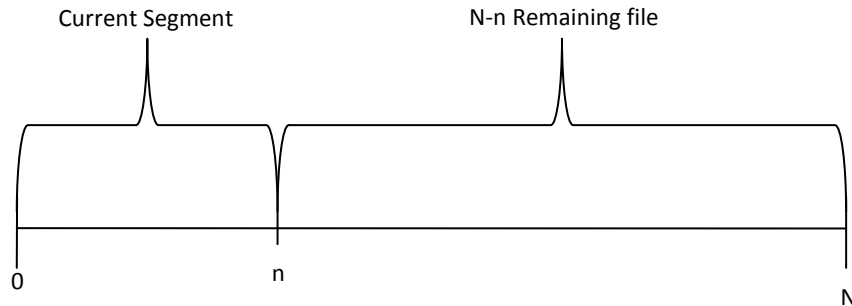
```

LOW = LOW + RANGE * Cum_Freq_Local[ symbol-1)]/ total_steps
Encoder_Scale()
local_model=Model_Update(symbol)
global_model=Model_Update(symbol)
If Can_Partition(n,N, global_model,local_model)
    Local=Restart_Model()
    Output_Termination()

```

---

Recall the partition condition  $nH_1 \leq nH_{approx,total} - (N - n)\log_2(N - n)$  where N is the total file size, n is the size of the current segment.



**Figure 4.6.** File location

We will also have some signaling to signify the end and beginning of code blocks. In this case we will use 128 bits.

**Algorithm 4.11.** Operation to test if the file can be partitioned

---

```

Can_Partition(n,N, global_model,local_model)
    Happrox=Markov(global,N)
    Can Partition:
        if  $n * Entropy(Local) < N * H_{approx} - (N-n) * \log_2(N-n)$ 

```

---

**Algorithm 4.12.** Operation to predict symbols based on global model

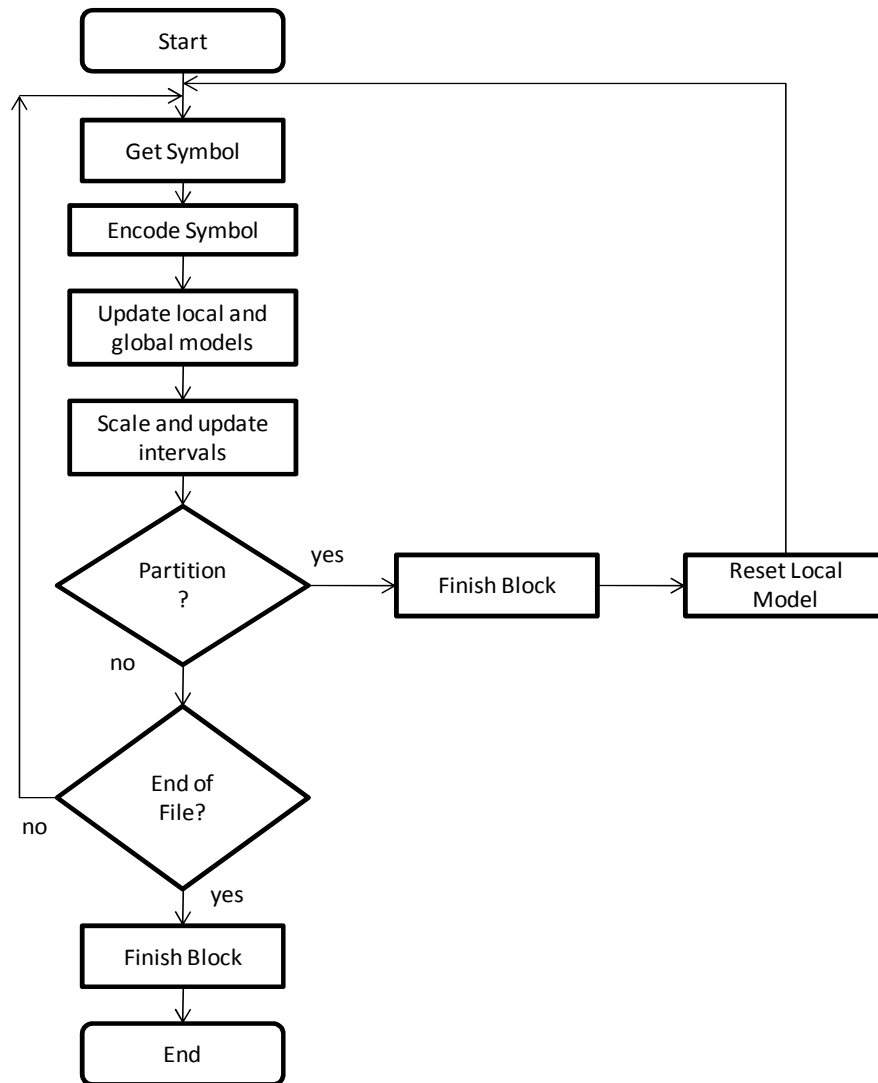
---

```

Markov(global,N)
    For N characters
        j=max_symbol(transition(j,k))
        temp_Model_Update(j)
    Entropy=temp_Model_Entropy

```

---



**Figure 4.7.** Encoder with block partitioning flowchart

## Decoder

The difference between the modified decoder and the normal decoder is that we now check for termination condition. The termination condition tells the decoder to restart the model and get another termination coding for the next partition.

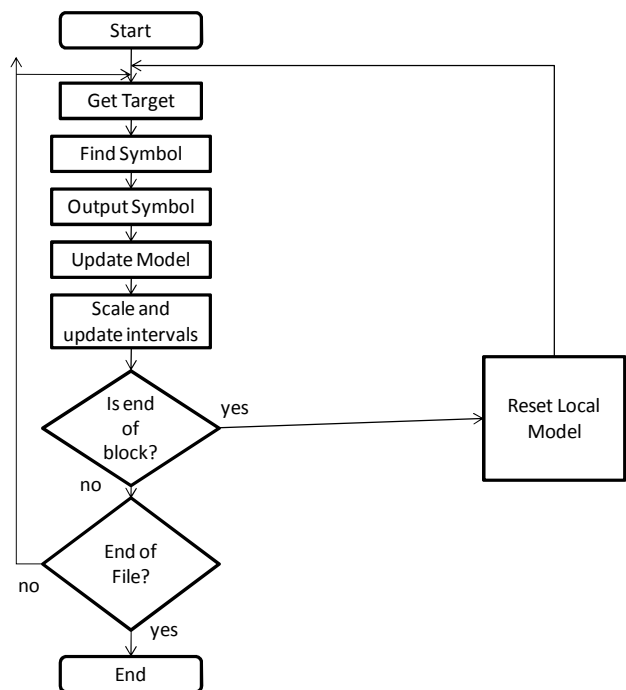
### **Algorithm 4.13.** Operation to decode a file

#### **Decoder(file)**

*Start with LOW=0 and HIGH=0x7FFFFFFF*  
*Get encoded block termination signals*  
*Get target from file*  
*Until end of file*

*Continued on next page*

$RANGE = HIGH - LOW + 1$   
 $Code = (target - LOW) / (Range / total\_freq)$   
 $Symbol = FindSymbol(Code)$   
 Output symbol  
 $HIGH = HIGH + (RANGE * Cum\_Freq[ symbol ] / total\_steps) - 1$   
 $LOW = LOW + RANGE * Cum\_Freq[ symbol - 1 ] / total\_steps$   
 Decoder\_Scale(target)  
 Model = Model\_Update(symbol)  
 If block termination reached  
     Model = Restart\_Model()  
 Get encoded block termination signals  
 Get target from file



**Figure 4.8.** Decoder with block partitioning flowchart

### Example 4.1

**Table 4.1.** Encoding table for word HELLO

Input	Symbol low	Symbol High	Total freqs	Low	High	Scaled High	Scaled Low	Operations	Output
H	72	73	257	609985590	609985590	184248614 3	772922368	E2 E1 E2 E2 E3 E3 E3	100
E	69	70	258	106311408 7	105896849 2	157426687 9	512994304	E2 E1 E1 E1 E1 E1 E1 E2	111111111 0
L	78	79	259	836702886	832605310	211637401 5	18414592	E2 E1 E1 E2 E2 E2 E1 E1 E3	1100011
L	78	80	260	663940511	647802364	169000345 5	657161984	E2 E1 E2 E2 E1 E1	110011
O	83	84	261	989570731	985613485	207452057 5	106146534 4	E2 E1 E1 E1 E2 E1 E2 E1	1110101



**Table 4.2.** Decoding table for word HELLO

Buffer	Value	Total	Symbol	Symb ol Lower Bound	Symb ol Upper Bound	High	Low	Operati ons	Scaled High	Scaled Low
6038741 50	72	257	H	72	73	609985590	601629624	E2(1) E1(1) E2(1) E2(0) E3(1) E3(0) E3(1)	18424861 43	77292236 8
1060221 813	69	258	E	69	70	1063114087	105896849 2	E2(1) E1(1) E1(1) E1(1) E1(0) E1(1) E1(1) E2(1)	15742668 79	51299430 4
8338447 27	78	259	L	78	79	836702886	832605310	E2(0) E1(0) E1(0) E2(0) E2(0) E2(0) E1(0) E1(0) E3(0)	21163740 15	18414592
6529960 96	78	260	L	78	80	663940511	647802364	E2(0) E1(0) E2(0) E2(0) E1(0) E1(0)	16900034 55	65716198 4
9895608 32	83	261	O	83	84	989570731	985613485	E2(0) E1(0) E1(0) E1(0) E2(0) E1(0) E2(0) E1(0)	20745205 75	10614653 44

## **Chapter 5**

### **Implementation of Huffman Coding**

Two conditions have to be met for implementing the adaptive Huffman program. First is the sibling property as described in [7], and the second is that every internal node must precede any leaf.

#### **Node**

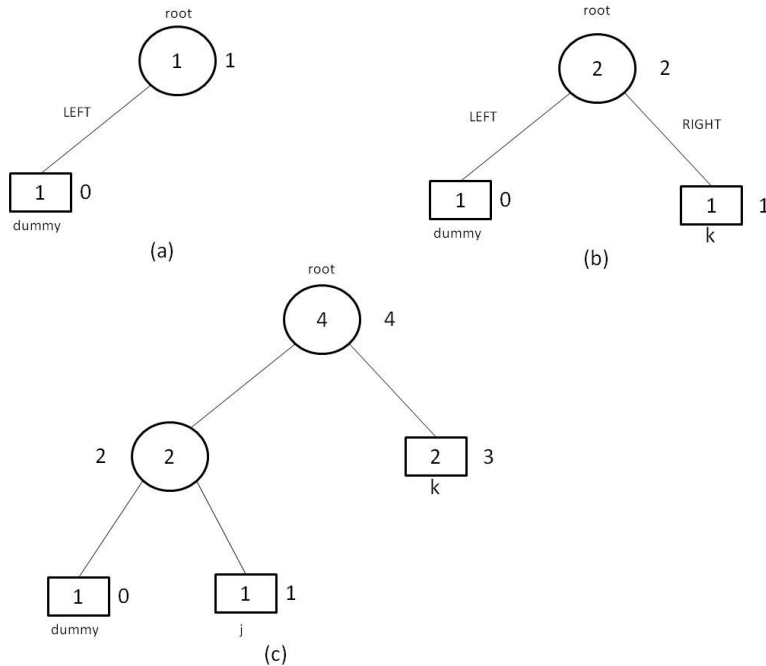
The nodes in the tree have several properties: parent, weight, orientation, type, left, and right. The parent property refers to a node's parent. The weight property refers to the frequency value of a node or its children. The node orientation refers to its position in respect to its parent. The orientation can be left or right. The type property specifies if the node is an internal node, a leaf, or the root. The left and right properties refer to left and right children of a node.

#### **Tree**

The tree contains a collection of nodes in an ordered list. The Huffman tree essentially is the code, therefore maintaining the tree is essential. There are three essential operations on the tree: insert, add, and reorder. The insert operation is called when a new symbol is observed. The add operation is called when an already observed symbol is once again encountered. The reorder operation is called whenever after both the insert or add operations. It ensures that the tree maintains correct numbering and satisfies the sibling property.

# Tree Operations

The tree initially is composed of the root and the zero or dummy node. In the first insertion, the new node is the root's right child. In subsequent insertions, a new parent node is created and inserted in the position of the dummy leaf. The dummy leaf and the leaf for the new symbol are the new parent's left and right child respectively. To keep consistent numbering, the new parent is numbered two; the new node is numbered one, and the dummy node remains number 0. The rest of the nodes are shifted to accommodate this numbering.



**Figure 5.1.** (a) Initial tree with the root and dummy leaf (b) Inserting the first symbol k (c) Inserting a symbol j

**Algorithm 5.1.** Operation to insert a new symbol into the tree

*Insert\_Symbol(newSymbol)*

*Shift\_list()*

*Create\_Node(newSymbol)*

*If only dummy node*

*Continued on next page*

```

    Right(root)=new_Node
Else
    Create New Parent
    Left(Parent(zero))=NewParent
    Parent(zero)=NewParent
    Parent(newSymbol)=NewParent
    Right(NewParent)=new_Node
    Left(NewParent)=zero
    Update_Immediate_Parents(Parent,old_node,new_node,wt_difference)
        Update_Distant_Parents(Parent2,node2,node1,Weight_Difference)
    Reorder_Tree(Number(NewParent))

```

---

**Algorithm 5.2.** Operation that shifts the node list to accommodate the new nodes

---

```

Shift_List()
    For all nodes
        List(i+2)=List(i)

```

---

The add operation serves two purposes. The first is whenever we encounter the add situation in the encoding operation. Not only do we increment the leaf and its parent's weights, but we also output the path to the leaf, with 0 being a move to the left child and 1 a move to the right child. The second situation happens whenever we decode a bit sequence until we reach a leaf. Here we simply increment the value in the decoded leaf and its parents.

**Algorithm 5.3.** Operation to increment an already observed symbol during encoding

---

```

Add_Symbol(symbol)
    Starting from Current=root
    If Value(current)=symbol
        Weight(current)=Weight(current)+1
        Update_Immediate_Parents(Parent,invalid,invalid,1)
        Update_Distant_Parents(Parent2,invalid,invalid,1)
        Reorder_Tree(Number(current))
        Stop
    If IsChild(Right(current),symbol)

        Current=Right(current) and Output 1
    If IsChild(Left(current),symbol)
        Current=Left(current) and Output 0

```

---

**Algorithm 5.4.** Operation to increment an already observed symbol during decoding

---

*Add\_Leaf(current\_leaf)*

*Weight(current)=Weight(current\_leaf)+1*

*Update\_Immediate\_Parents(Parent,invalid,invalid,1)*

*Update\_Distant\_Parents(Parent, invalid,invalid,1)*

*Reorder\_Tree(ADD)*

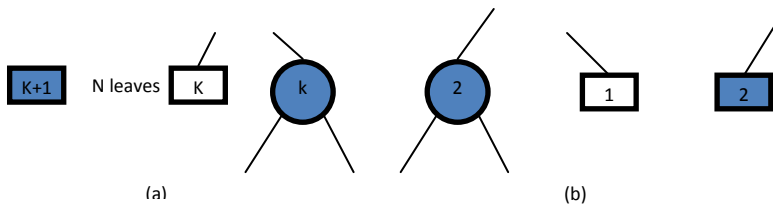
---

The reorder operation is the most important operation in the Huffman implementation. From previous operations, we know that the tree is ordered except possibly in the position of the node inserted or added. This node is either has a weight greater than some node(s) higher in the list or it violates Vitter's condition. The nodes higher in the list consist of nodes with previously had higher weights. In order to test for compliance to the conditions we go through the list to find a lower numbered node with higher weights than the higher numbered node. We store the positions where swapping is possible. We swap the node with the highest numbered node that violates the properties. If no swapping is possible, we move to the node's parent node and continue comparisons until we reach the root. On a swap, we have to be aware of two situations for node traversal. If we swap two nodes of the same type, we can make the swapped node's parent the next node for comparison. When there are two nodes of a different type the tree might not comply with the node precedence condition or the sibling property. Let us look at the situations where this could happen.

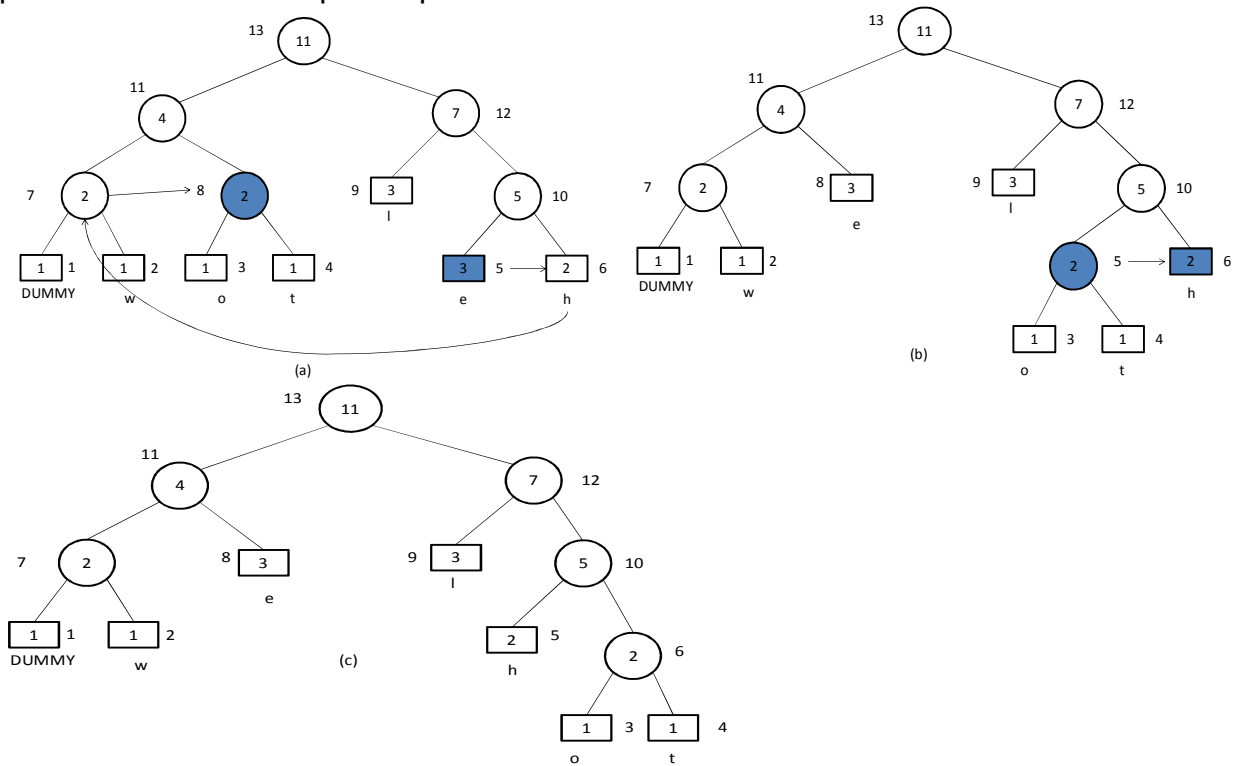
Imagine a situation in which we have a leaf for symbol "H" with weight k followed by N leaves with weight k and an internal node of weight k. If we receive a new "H", according to our reorder procedure, the leaf for "H" and the internal node would be swapped. If we were to move on the internal node's parent, the node precedence

condition would stay unsatisfied. Therefore, in this situation we would have to return to the swapped node and start the comparisons from that node.

The second situation occurs during the insert operation. When we create a new node and give it a weight of two. If we have a distant leaf of weight two and we perform a swap. If we have a node in between these two nodes, the swap would cause the tree to violate the sibling property. We also have to return to the previous position to continue the comparisons.



**Figure 5.2.** Conditions in which swapping would require a return to the swapped position instead of the parent position.



**Figure 5.3.**(a) Tree after incrementing “e”. Node traversal shown by arrows starting from “e”. Nodes to be swapped are shaded. (b) Tree after leaf 9 and leaf 5 are swapped.(c) Tree after nodes 5 and 6 are swapped

---

**Algorithm 5.5.** Operation to reorder the tree nodes after an add or insert operation

---

**Reorder\_Tree**(Start\_number)

Swap\_pos=invalid

Until the end of the node list

    For all nodes  $i$  starting from Start\_number

        If(Weight( $i$ )>Weight( $i+k$ ))

            Swap\_pos= $i+k$

        Else

            If swap\_pos is valid

                Swap( $i$ , swap\_pos)

                If nodes are of different types

                    Go to next node  $i$

                Set node  $i$  to parent of swapped position

---

---

**Algorithm 5.6.** Operation to swap two nodes

---

**Swap**(node1,node2)

    Temp=Number(node1)

    Number(node1)=Number(node2)

    Number(node2)=Number(node1)

    Parent1=Parent(node1)

    Parent2=Parent(node2)

    Weight\_Difference=Weight(node1)-Weight(node2)

    Update\_Immediate\_Parents(Parent1,node1,node2, Weight\_Difference)

    Update\_Distant\_Parents(Parent1,node1,node2,Weight\_Difference)

    Update\_Immediate\_Parents(Parent2,node2,node1, Weight\_Difference)

    Update\_Distant\_Parents(Parent2, node2,node1,Weight\_Difference)

---

---

**Algorithm 5.7.** Operation to swap a node's immediate parents

---

**Update\_Immediate\_Parents**(Parent,old\_node,new\_node,wt\_difference)

    If(Orientation(old\_node)=Right)

        Right(Parent)=new\_node

    Else

        Left(Parent)=new\_node

    If old\_node and new\_node are valid

        Remove\_Child(Parent,old\_node)

        Add\_Child(Parent,new\_node)

        Weight(Parent)=Weight(Current)+wt\_difference

---

---

**Algorithm 5.8.** Operation to swap a node's ancestors

---

**Update\_Distant\_Parents**(Parent,old\_node,new\_node,Weight\_Difference)

    Current=Parent

    Until current=root

        Current=Parent(Current) & Weight(Current)=Weight(Current)+Difference

        If old\_node and new\_node are valid

            Remove\_Child(Current,old\_node) and Add\_Child(Current,new\_node)

---

# Encode

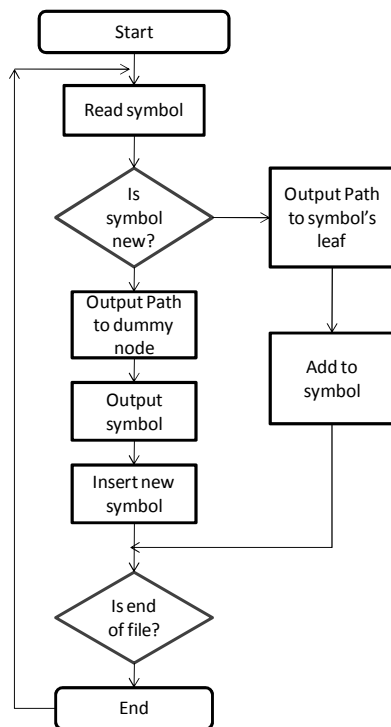
In the encoding of the file, a symbol is encoded as it is observed. If observed for the first time, we output the code for the dummy leaf followed by the symbol itself. This will signal to the decoder that it is a first occurrence. For an already observed symbol its code from the tree is outputted. The code tree is updated after both the insert or the add operations.

## Algorithm 5.9. Operation to encode a file

---

```
Encode(file)
  For all symbols in file
    Get symbol
    If(Is_First_Occurence(symbol))
      Output zero occurrence
      Output symbol
      Insert_Symbol(symbol)
    Else
      Add_Symbol(symbol)
      Reorder tree()
```

---



**Figure 5.4.** Encoding flowchart



## Decode

In decoding the file, we follow the bit sequence in the file bit by bit. If the observed bit is 1 we traverse to the right of the current node, if it is zero we traverse to the left. We do this until we reach a leaf. If we reach the dummy leaf, we read the next symbol in the file and then output it to the output file. If we reach another leaf besides the dummy, we output the symbol inside the leaf.

---

### Algorithm 5.10. Operation to decode a file

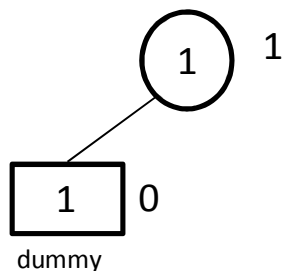
---

```
Decode(file)
  Current=root
  Until the end of file
    Read bit
    If bit is 0
      Current=Right_Child(current)
    Else
      Current=Left_Child(current)
    If current is a leaf
      Output current(symbol)
      Add_Leaf(current)
      Set Current=root
    If current=dummy
      Read symbol
      Output symbol
      Insert_Symbol(symbol)
      Set Current=root
```

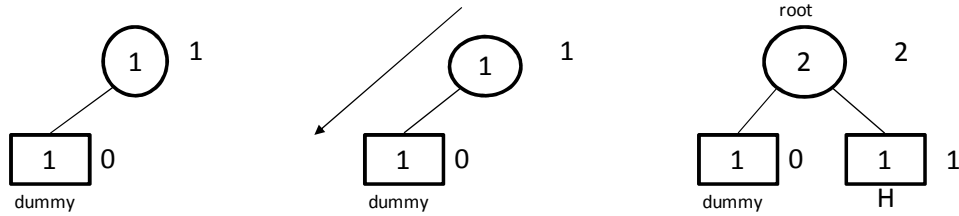
---

### Example 5.1

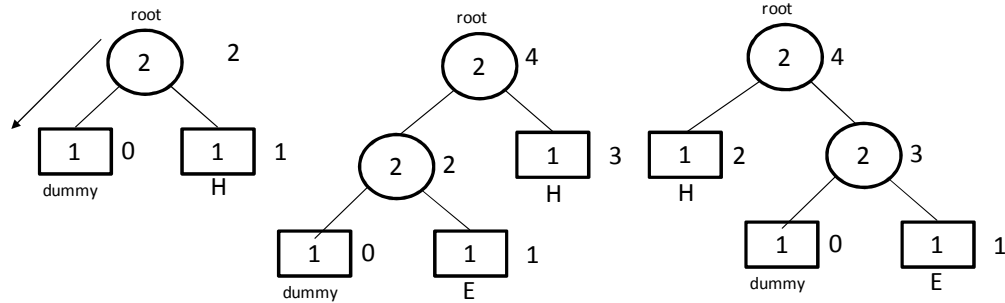
Encoding for the word HELLO



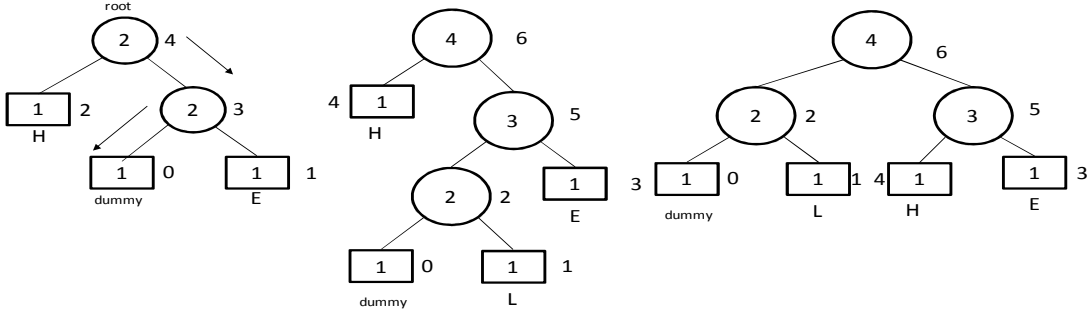
**Figure 5.5.** Initial tree



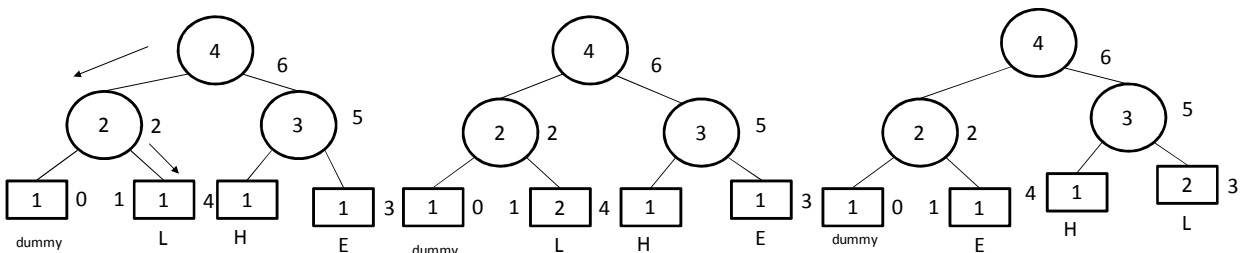
**Figure 5.6.** Inserting "H". Operation: output 0, output "H", insert H



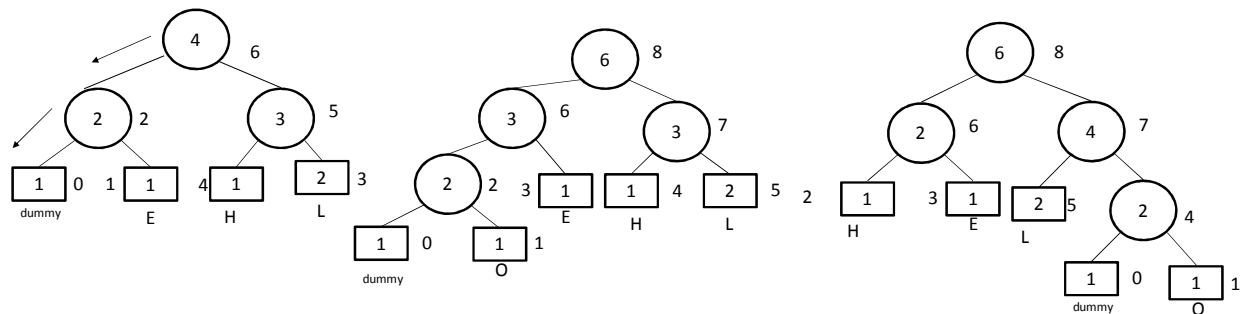
**Figure 5.7.** Inserting "E". Operation: output 0, output "E", insert "E", reorder tree



**Figure 5.8.** Inserting "L". Operation: output 10, output "L", insert "L", reorder tree

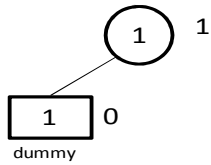


**Figure 5.9.** Adding "L". Operation: output 01, increment "L", reorder tree

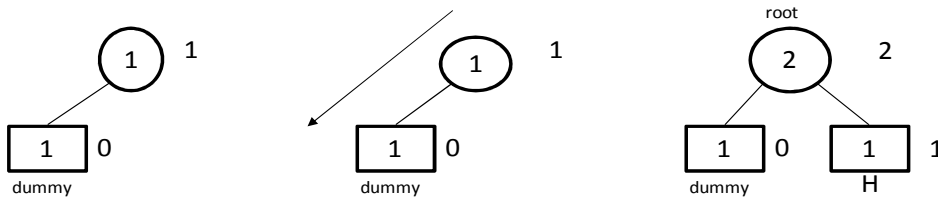


**Figure 5.10.** Inserting "O". Operation: output 00, output "O" insert "O", reorder tree

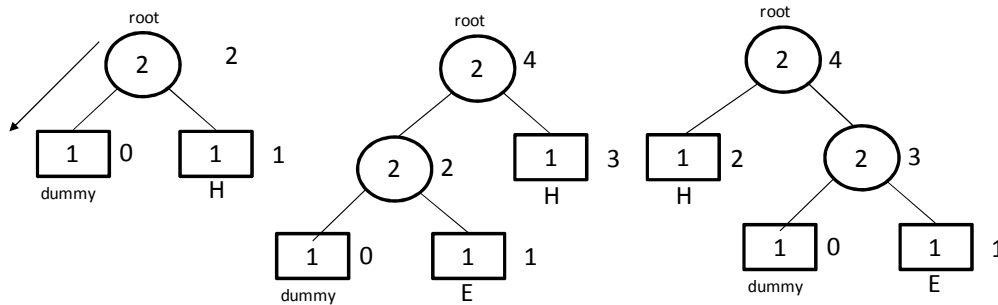
Decoding  
 Input buffer: 0H0E10L01000



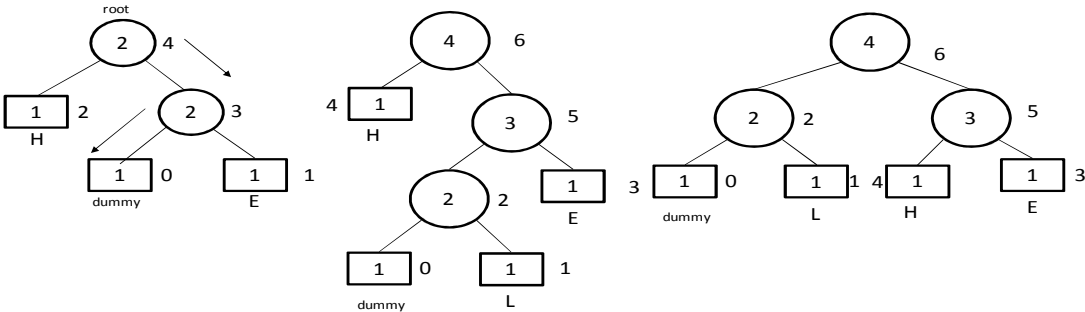
**Figure 5.11.** Initial tree



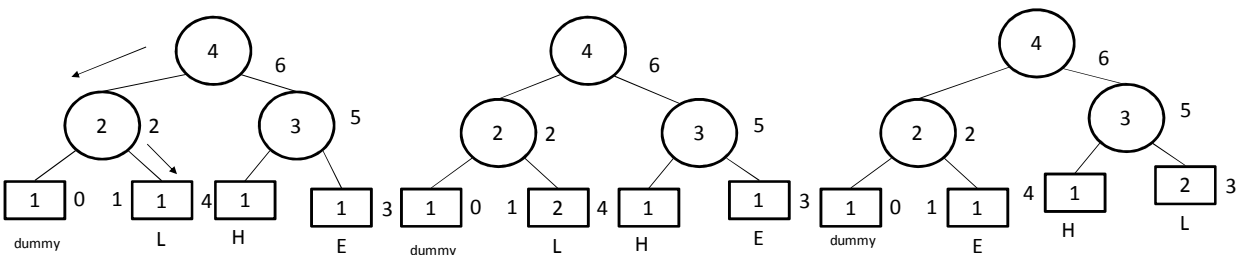
**Figure 5.12.** Read 0. Read "H". Operation: output "H", insert H



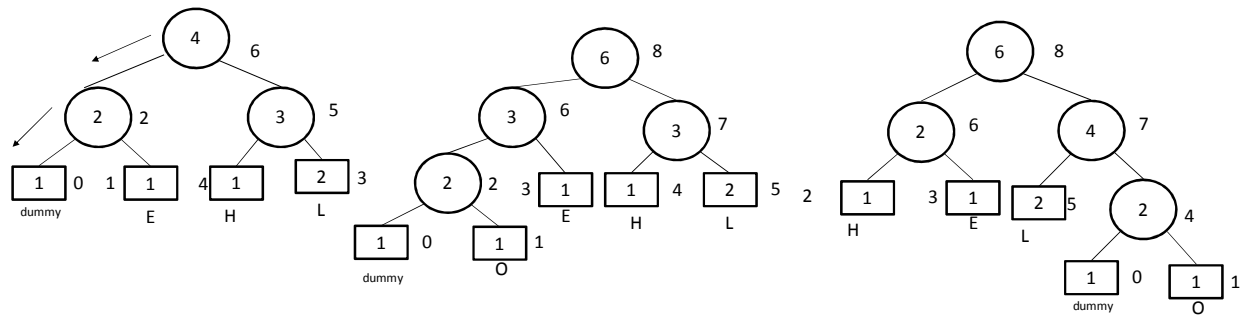
**Figure 5.13.** Read 0. Read "E". Operation: output "E", insert "E", reorder tree



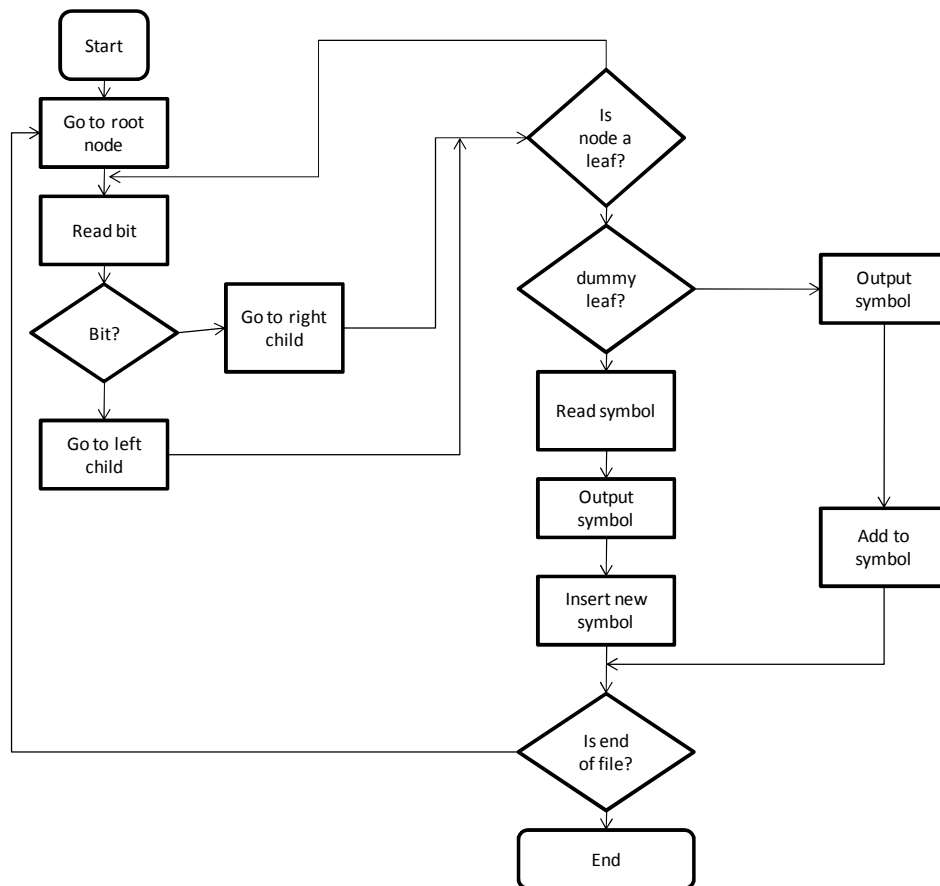
**Figure 5.14.** Read 01. Read "L". Operation: output "L", insert "L", reorder tree



**Figure 5.15.** Read 01. Operation: output "L", increment "L", reorder tree



**Figure 5.16.** Read 00. Read “O”. Operation: output “O” insert “O”, reorder tree



**Figure 5.17.** Decoding flowchart

In this chapter, we implement an adaptive Huffman algorithm that satisfies both the sibling property and Vitter’s implicit numbering. There are several differences between this implementation and Vitter and FGK. The first difference is that instead of updating the tree before adding a new symbol to the tree, this implementation updates after the symbol is added. The second difference is that the dummy node is given a

weight of one instead of zero. This changes the updates when a new unobserved symbol is inserted into the tree. The new parent node moves up the tree quicker in the beginning of the files.

## **Chapter 6**

### **Simulation Results**

For the results we created six files with differing measures of information. The files were compressed using adaptive Arithmetic coding, Huffman coding, and modified Arithmetic coding. The main testing parameter is the compression ratios of the various algorithms.

#### **Files**

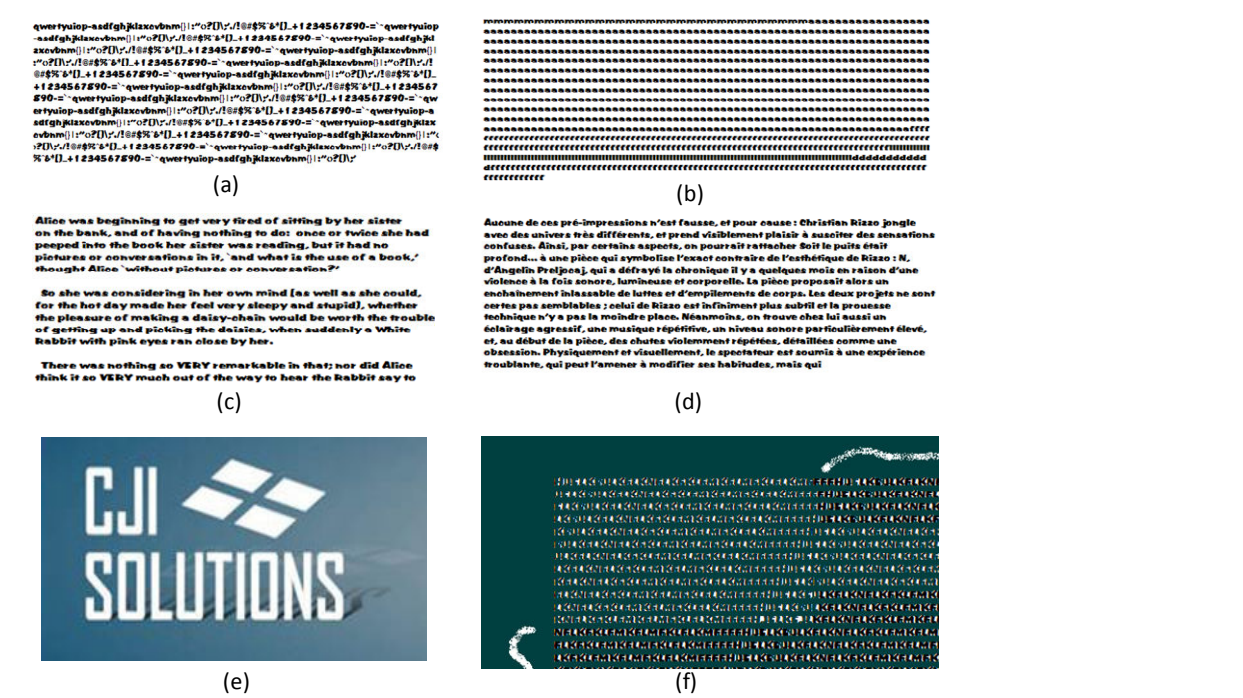
There were three file types used in the compressions: character file, language text, and image files. The character files were sequences of characters in no particular order. The first file, Chars2.txt, was a 108732 byte character file. It was high entropy and low redundancy. The second file was a 200889 byte character file. The file was low entropy, high redundancy file. For the language files, two files were used. The first file was a 152089 byte file of English text, and the second file was a 133754 byte file of French text. The image files consisted of a 141168 byte simple image, Simple.bmp, and a 109674 byte complex image, Logo.bmp.

#### **Results**

As expected, Arithmetic coding yielded slightly better compression ratios than the Huffman coding. In complex files the normal Arithmetic coding yielded results slightly better than the modified version by less than a percent. On the simple files the modified

version created two or three partitions. In the instance of the simple image file, it outperformed the Arithmetic coding.

In the results, the modified coder was able to take advantage of the characteristics of the files to produce a file with more partitions and satisfactory compression ratio. In the more complex files, chars2.txt and Logo.bmp, the coder was conservative. The slight loss of compression arose from the processing overhead. In the other files, the coder was able to partition into two or more blocks.



**Figure 6.1.** (a) Chars2.txt (b) Chars.txt (c) English.txt (d) French.txt (e) Logo.bmp (f) Simple.bmp

**Table 6.1.** Compression Results

File Attributes		Compression Attributes			
File Name	File Size	Algorithm	Size	Partitions	Ratio
chars2.txt	108732	Adapt. Huffman	84553	1	0.222372439
		Normal Adapt. Arithmetic Coding	82615	1	0.240196078
		Modified Arithmetic Coding	82623	1	0.240122503

Continued on next page

chars.txt	200889	Adapt. Huffman	43446	1	0.783731314
		Normal Adapt. Arithmetic Coding	41388	1	0.793975778
		Modified Adapt. Arithmetic Coding	40565	3{140616,40176,20097}	0.798072567
English.txt	152089	Adapt. Huffman	87795	1	0.422739317
		Normal Adapt. Arithmetic Coding	87136	1	0.427072306
		Modified Adapt. Arithmetic Coding	87336	2{121664,30425}	0.425757287
French.txt	133754	Adapt. Huffman	77125	1	0.423381731
		Normal Adapt. Arithmetic Coding	76744	1	0.426230244
		Modified Adapt. Arithmetic Coding	76844	2{107000,26754}	0.425482602
Logo.bmp	109674	Adapt. Huffman	98259	1	0.104081186
		Normal Adapt. Arithmetic Coding	97622	1	0.109889308
		Modified Adapt. Arithmetic Coding	97630	1	0.109816365
Simple.bmp	141168	Adapt. Huffman	89863	1	0.363432223
		Normal Adapt. Arithmetic Coding	86175	1	0.389557123
		Modified Adapt. Arithmetic Coding	85710	3{266063,76018,38017}	0.392851071

## Discussion

From the results, we see that modified coder was able to create partitions for most of the files. More complex files have the least amount partitions. In fact, the most complex files, Chars2.txt and Logo.bmp, have no partitions. The two files with least



complexity, Chars.txt and Simple.bmp, created three partitions each. The two files with English and French text created two partitions each.

The files with lower entropy are more likely to be partitioned because the left side of the equation  $nH_1 \leq NH_{approx,total} - (N - n)\log_2(N - n)$  is smaller for those files. This makes the test for partition more likely to pass.

Taking a close examination of the partitions created by the coder, we see that the first partition is significantly larger than the subsequent partitions. The reason for this is in the way that future symbols are predicted. Our Markov model starts by creating symbols based on the previous occurrences and transitions of the symbols. After all the symbols have been visited for at least their frequency of occurrence in the files, all the symbols are equally probable. All subsequent symbol predictions will visit any symbol with equal frequency. Therefore, the entropy of the generated symbols will approach maximum entropy. This maximum entropy increases with ratio of remaining file size to current segment size,  $N/n$ . The higher the ratio, the higher that entropy becomes. Therefore,  $N \approx N-n$  and  $H_{approx,total} \approx \log_2(N-n)$ . Once the test for the partition condition is administered using  $nH_1 \leq NH_{approx,total} - (N - n)\log_2(N - n)$ , the right side will approach zero. In order for the test to pass,  $n$  has to be significantly large and  $H_1$  has to be significantly low.

## **Conclusions and Future Work**

In this thesis we covered the theory of data compression. We created implementations of Huffman and Arithmetic coding. We optimized the compression ratio of a system using Arithmetic coding and Markov models. We were able to create a greedy algorithm that partitions the data by predicting compression size. We also showed in our simulations that our partitions show little loss in compression ratio, and, at times, it improved the compression ratio.

Next efforts in optimizing the data compression system would be in combining our technique with data preprocessing techniques. In particular, we can use techniques such as Run-length encoding, Burrows-Wheeler transform, and Move-To-Front coding [1]. Each of these techniques changes the complexity of data, therefore, changing the effect of predictive compression.

Markov prediction models can also be applied to other compression techniques. We can explore its application to video compression. We compare Markov prediction to existing variable block size techniques used in video. One of the classical problems in video and image compression is DCT block size selection. We can study how to apply prediction to solve this problem.

Now that we have shown its effectiveness in a data compression system, the next step is to show how the system would help in classical packet optimization situations. These include wireless systems where noise is high and highly congested systems with high packet loss. We can next study the effects of constraining the packet sizes based not only on measures of noise and congestion, but also our reduction of compression ratio.

# **Bibliography**

1. Blellock, Guy E. "Introduction to Data Compression." Carnegie Mellon University. 16 October 2001.
2. Bodden, E., Clasen, M., & Kneis, J. (2002). Arithmetic Coding Revealed: A guided tour from theory to praxix. *Seminar Data Compression* .
3. Cleary, John G., Radford M. Neal, and Ian H. Witten. "Arithmetic Coding for Data Compression." Communications of the ACM 30(1987): 520-540.
4. Eytan, Modiano. "An Adaptive algorithm for optimizing the packet size used in wireless ARQ protocols." Wireless Networks 5(1999): 279-286.
5. Gallager, R. G., 1978. Variations on a theme by Huffman. *IEEE Transactions on Information Theory*, Vol. 24, pp. 668-674, November 1978.
6. Hoffman, Roy. Data Compression in Digital Systems. New York: Chapman & Hall, 1997.
7. Khalid, Sayood. Lossless Compression Handbook. San Diego: Academic Press Series in Communications, Networking, and Multimedia, 2003.
8. Korhonen, Jari, and Wang. "Effect of Packet Size on Loss Rate and Delay in Wireless Links." IEEE Communications Society 3(2005): 1608 - 1613.
9. Massey, Greg, and Jon McClintock. "Packet Size Matters in IP Transport." Radio World 2006:
10. Moffat, Alistair, Radford M. Neal, and Ian H. Witten. "Arithmetic Coding Revisited." ACM Transactions on Information Systems 16(1998): 256-294.
11. Pu, Ida Mengyi. Fundamental Data Compression. Oxford: Butterworth-Heinemann, 2006.
12. Roman, Steven. Coding and Information Theory. New Work: Springer-Verlag, 1992.
13. Ross, Sheldon M. Introduction to Probability Models. 8. New Work: Academic Press, 2003.
14. Saeed, Faisal, Huizhu Lu, and G. E. Hedrick. "Data compression with Huffman coding; an efficient dynamic implementation using file partitioning." Proceedings of the 1990 Symposium on Applied Computing (1990): 348-354.

15. Shannon, Claude E., and Warren Weaver. The Mathematical Theory of Communication. 1. Chicago: The University of Illinois Press, 1969.
16. Vitter, J.S, 1987. Design and analysis of dynamic Huffman codes. *Journal of the ACM*, Vol. 34, pp. 823-843, October 1987.

## **Vita**

Claudio Iombo is a native of Cabinda, Angola. Angola is a country in the Southwest coast of the continent of Africa. He is a graduate of Louisiana State University in electrical and computer engineering in December 2003. He is currently a candidate for master's degree in the Department of Electrical and Computer Engineering at Louisiana State University. His interests include communication and software systems design.