



---

All Theses and Dissertations

---

2016-05-01

# Placental 'PADSOS' Omics 'PADSGCE' Study to Understand the Pathogenesis of Preeclampsia

Komal Kedia

Brigham Young University - Provo

Follow this and additional works at: <https://scholarsarchive.byu.edu/etd>

 Part of the [Biochemistry Commons](#), and the [Chemistry Commons](#)

---

## BYU ScholarsArchive Citation

Kedia, Komal, "Placental 'PADSOS' Omics 'PADSGCE' Study to Understand the Pathogenesis of Preeclampsia" (2016). *All Theses and Dissertations*. 5876.

<https://scholarsarchive.byu.edu/etd/5876>

This Dissertation is brought to you for free and open access by BYU ScholarsArchive. It has been accepted for inclusion in All Theses and Dissertations by an authorized administrator of BYU ScholarsArchive. For more information, please contact [scholarsarchive@byu.edu](mailto:scholarsarchive@byu.edu), [ellen\\_amatangelo@byu.edu](mailto:ellen_amatangelo@byu.edu).

Placental 'Omics' Study to Understand the Pathogenesis of Preeclampsia

Komal Kedia

A dissertation submitted to the faculty of  
Brigham Young University  
in partial fulfillment of the requirements for the degree of  
Doctor of Philosophy

Steven W. Graves, Chair  
Steven R. Goates  
Mathew R. Linford  
Paul B. Farnsworth  
Matt A. Peterson

Department of Chemistry and Biochemistry

Brigham Young University

May 2016

Copyright © 2016 Komal Kedia

All Rights Reserved

## ABSTRACT

### Placental ‘Omics’ Study to Understand the Pathogenesis of Preeclampsia

Komal Kedia

Department of Chemistry and Biochemistry, BYU

Doctor of Philosophy

Preeclampsia (PE) is a potentially fatal complication of pregnancy characterized by an increase in blood pressure ( $>140/90$  mmHg) and proteinuria ( $>300$  mg/24 hrs), often accompanied by edema. Symptoms of PE start after 20 weeks of gestation. If PE remains untreated, it can lead to eclampsia, grand-mal seizures responsible for most fatalities. PE is believed to affect 2-10% of pregnancies worldwide, and claims the lives of over 75,000 mothers and 500,000 newborns yearly.

No therapeutic agents have been developed to prevent or cure PE. Part of the reason for this is the absence of a complete understanding of the pathogenesis of this disease. PE has long been regarded as a “disease of theories”, and the pathophysiology of PE continues to be the subject of debate. Nonetheless, several abnormalities have been observed to precede established, clinical PE and have in turn been proposed to be involved in the causation of this disease, all with involvement of the mother’s placenta as a central feature. Removal of placenta is the only cure for PE and results in a rapid resolution of the symptoms. Thus, the placenta remains an organ of substantial interest and many research groups have attempted to identify abnormal placental features occurring in PE. None of these studies have focused on less abundant, low molecular weight (LMW) biomolecules, which play important roles in the pathophysiology of many diseases.

There are a number of alterations that are believed to affect the placenta and contribute to the pathogenesis of PE. The most widely accepted ones include hypoxia, oxidative stress, and an increase of pro-inflammatory mediators in the mother’s placenta. The goal of my initial study was to identify which of these hypothesized causative pathways has a significance in the etiology of this syndrome as well as to investigate which less abundant, low molecular weight biomolecules change in response to these abnormalities. For this purpose, we first adapted and optimized a previously developed methodology that studied LMW biomolecules in tissue specimens to study placental biomolecules. This approach involved a tissue homogenization step followed by protein depletion using acetonitrile. We compared two regions of human placenta: the chorionic plate and the basal plate to find differences in the LMW fraction. We discovered 16 species with statistically significant differences between the two sides, and identified 12 of them using tandem mass spectrometry.

In the second study we collected normal human term placentas from elective C-section deliveries and exposed explants to each of the above-mentioned provocative agents or stress conditions for 48 hrs. Other explants without any stressors were cultured in parallel for the same amount of time. The processing of explants was divided into five steps: 1) explant culture; 2) tissue homogenization; 3) acetonitrile precipitation to remove high abundance, high molecular weight proteins; 4) injection of the protein-depleted specimen into a capillary liquid chromatography–mass

spectrometer; 5) analysis of MS data to identify quantitative differences between cases (stressed explants) and controls (normal explants). In total, we observed 146 molecules changed in abundance between the treated explants and the controls with 75 of these molecules changed in response to hypoxic treatment, 23 changed due to hypoxia-reoxygenation, a process generating reactive oxygen species, and 48 changed due to tumor necrosis factor- $\alpha$  (TNF $\alpha$ ), a pro-inflammatory cytokine. We were successful in identifying 45% of all these molecules by tandem MS. Statistical modeling that applied LASSO analysis allowed for the development of a model that used 16 of the 146 differentially expressed biomolecules to accurately classify and differentiate each of the 4 stressed conditions.

In my third study, I then submitted actual preeclamptic and non-diseased placental tissue to our established homogenization and acetonitrile precipitation protocol to see if any of the differences in LMW biomolecules produced under stress conditions in normal placenta were recapitulated in actual diseased placenta. In a preliminary statistical analysis, 8 of the original 146 differentially expressed species, displayed significant or near significant changes in the actual disease placenta. After applying two stringent statistical tests that eliminated any potential influence of gestational age, four out of the 146 biomarkers previously studied, continued to be differentially expressed in both stringent analyses. Of the four, 1 biomarker (m/z 649.49 (+1)) showed an increased abundance in hypoxic placental explants as well as in PE placenta; 2 (461.06 (+1), 476.24 (+1)) were increased in response to TNF $\alpha$ -exposed placental explants and in these PE placentas and 1 (426.35 (+1)) increased in response to hypoxia-reoxygenation-treated placental explants was also increased in PE placenta. We have chemically characterized 2 of the 4 biomarkers. One was a phospholipid (m/z 476.24) while the other was an acylcarnitine (m/z 426.35). This suggests that features of PE appear to arise from the predicted early abnormalities that affect the placenta.

In conclusion, I was successful in developing an 'omics' approach to study less abundant, low molecular weight biomolecules in human placenta as well as investigate which biomarkers show differential expression in human placenta when exposed to proposed abnormalities of PE and have data to suggest that these same responses are present in PE placenta .

Keywords: Tissue proteomics, top-down, capillary liquid chromatography-MS, low-molecular-weight proteins, placenta, peptidomics, lipids, metabolites

## ACKNOWLEDGMENTS

I would like to express sincere gratitude to my advisor Dr. Steven W. Graves for providing me this wonderful opportunity to participate and perform research in his lab. His unwavering support, guidance and encouragement helped me become a better scientist, and made my experience as a graduate student very pleasant. I am also grateful to my research collaborator Dr. Craig D. Thulin for his encouragement, advice and extremely valuable insights into the field of proteomics. I would like to thank Bruce Jackson, the manager of the mass spectrometry center for his constant guidance and assistance with instrument related concerns. I will always be very appreciative to the department of chemistry and biochemistry, BYU for providing me with excellent opportunities to excel as a graduate student. In particular, I would like to thank our assistant graduate coordinator Janet Fonoimoana, whom I saw a friend in, for her help, kindness and constant encouragement throughout the program. Graduate and undergraduate students in particular Dr. Moana Hopoate, Dr. Tanielle Alvarez, Caitlin Nichols, Stephen Smith, Taryn Prestwich and Andrew Wright are acknowledged for their direct contribution to this work. I received a substantial amount of help in statistical analysis from Dr. Dennis Tolley and his graduate student Justin Barnes which I greatly appreciate. I would also like to express my appreciation to my co-workers Dr. Dipti Shah, Swati Anand and Ying Ding for creating a very fun-filled and positive atmosphere in the lab.

I also want to give credit to extremely talented professors in the chemistry department, especially my graduate committee members Dr. Steven Graves, Dr. Steven Goates, Dr. Paul Farnsworth, Dr. Matt Linford and Dr. Matt Peterson for their encouragement, valuable insights and reviews which helped me become better graduate student and researcher.

I am indebted to my mother Renu Kedia and father Anil Kedia for their unconditional love and faith in me. Amidst daily struggles, they created an environment full of positivity and happiness, which I am extremely grateful for. Additionally, my sisters Khushbu Kedia Lath and Radhika Kedia have always been my strongest supporters and a constant source of encouragement. I have been blessed with amazing relatives, who I know always keep me in their prayers. In particular, I would like to thank Tulsian family and Goenka family, without whom I would not be here, pursuing this education. Their blessings and constant support have played a very instrumental role in my career. I am grateful for the love and tolerance of Rohit Duhan. His kindness, patience and sacrifices made it possible for me to complete my work without many hurdles. He has been a key figure in this achievement.

*This dissertation is dedicated to my mother Renu Kedia and my late grandmother Gita Devi Kedia, the two women who made all the difference in my life.*

## TABLE OF CONTENTS

Placental ‘Omics’ Study to Understand the Pathogenesis of Preeclampsia .....	i
ABSTRACT .....	ii
ACKNOWLEDGMENTS .....	iv
TABLE OF CONTENTS.....	vii
LIST OF TABLES .....	xi
LIST OF FIGURES .....	xii
LIST OF ABBREVIATIONS.....	xiv
1. Introduction .....	1
1.1 Preeclampsia .....	1
1.1.1 History .....	1
1.1.2 Definition of PE.....	1
1.1.3 Epidemiology of PE.....	2
1.1.4 Conditions believed to be involved in the pathogenesis of PE: .....	3
1.1.5 The role of the placenta in PE .....	8
1.2 Biological mass spectrometry (MS).....	8
1.2.1 MS applications to complex biological specimens.....	8
1.2.2 Mass analyzers for biomolecules.....	10
1.2.3 Quadrupole MS.....	13
1.2.4 TOF.....	15
1.3 Proteomics.....	19
1.3.1 Pre-separation before MS .....	20
1.4 Lipidomics .....	23
1.5 Tissue analysis .....	26
1.5.1 Placental analysis.....	27
1.6 Importance of the LMW biomolecules and approaches to MS interrogation of smaller biomolecules.....	30
1.7 Layout of the dissertation.....	35
1.8 References.....	36
2. Novel ‘omics’ approach to study low abundance, low molecular weight components in a complex biological tissue: Regional differences between chorionic and basal plates of human placenta .....	44
2.1 Abstract.....	44



2.2	Introduction.....	45
2.3	Materials and methods .....	49
2.3.1	Tissue collection .....	49
2.3.2	Tissue homogenization .....	50
2.3.3	Protein depletion.....	50
2.3.4	Chromatographic separation.....	51
2.3.5	Mass spectrometric analysis .....	52
2.3.6	Time normalization and data analysis .....	52
2.3.7	Statistical analysis.....	53
2.3.8	Normalization of candidate markers to reduce non-biological variation .....	54
2.3.9	Identification of peptides of interest by tandem MS .....	54
2.3.10	<i>De novo</i> sequencing .....	55
2.3.11	Identification of lipid markers.....	55
2.4	Results.....	56
2.4.1	Time markers to align chromatographic elution times .....	56
2.4.2	Differentially abundant low abundance, LMW weight biomolecules between chorionic plate and basal plate.....	56
2.4.3	Identification of peptides .....	59
2.4.4	Identification of lipids .....	63
2.5	Discussion.....	67
2.6	Conclusion .....	73
2.7	References.....	74
3.	Global ‘Omics’ Evaluation of Human Placental Responses to Preeclamptic Conditions .....	80
3.1	Abstract.....	80
3.2	Introduction.....	81
3.3	Materials and methods .....	82
3.3.1	Specimen collection.....	82
3.3.2	Sample processing.....	83
3.3.3	Explant culture.....	83
<b>3.3.4</b>	<b>Homogenization of placental explants .....</b>	<b>84</b>
3.3.5	Mass spectrometric analysis .....	84
3.3.6	Statistical analysis.....	85
3.3.7	Peptide identification.....	86
3.3.8	Lipid identification .....	87
3.4	Results.....	87

3.4.1	Chromatographic time alignment .....	87
3.4.2	Low abundance, LMW weight species altered by PE conditions .....	87
3.4.3	Sequenced peptides.....	95
3.4.4	Lipid classification .....	96
3.4.5	Condition specific signatures.....	97
3.5	Discussion.....	100
3.6	References.....	112
4.	Targeted tissue ‘omics’ analysis comparing markers changed in culture in response to proposed mediators of preeclampsia to those markers in actual preeclamptic placentae.....	119
4.1	Abstract.....	119
4.2	Introduction.....	120
4.3	Methods.....	121
4.3.1	Tissue collection.....	121
4.3.2	Specimen processing.....	123
4.3.3	Chromatographic separation.....	123
4.3.4	Mass spectrometric analysis.....	124
4.3.5	Data analysis.....	124
4.3.6	Statistical analysis.....	125
4.4	Results.....	128
4.4.1	Chromatographic time alignment.....	128
4.4.2	Evaluation of 146 biomarkers that demonstrated differences under PE conditions in PE placenta .....	128
4.5	Discussion.....	135
4.6	Conclusion .....	139
4.7	References.....	140
5.	Concluding remarks.....	145
5.1	Summary of Current research.....	145
5.1.1	Summary: Chapter 2.....	145
5.1.2	Summary: Chapter 3.....	146
5.1.3	Summary: Chapter 4.....	146
5.2	Limitations of current research.....	147
5.2.1	Limitations: Chapter 2.....	147
5.2.2	Limitations: Chapter 3.....	148
5.2.3	Limitations: Chapter 4.....	149
5.3	Future objectives.....	150

5.3.1	Future research objective: Chapter 3 .....	150
5.3.2	Future research objectives: Chapter 4 .....	151
5.4	References.....	153

## LIST OF TABLES

Table 2.1. List of 16 differentially molecular species across all 10 time windows.	58
Table 2.2. Summary of the chemical identities of peptides differentially expressed in chorionic plate and basal plate of human placenta.	61
Table 2.3. Summary of the chemical classes and components of the lipids differentially expressed in chorionic plate versus basal plate of human placenta.	66
Table 3.1. List of differentially expressed biomolecules for all the three ‘stressed’ conditions. A. Hypoxia, B. Hypoxia-reoxygenation, C. TNF $\alpha$	90
Table 3.2. Condition specific changes in biomolecules	99
Table 3.3. Summary of categorized markers with their identifications and biological significance	102
Table 4.1. Mean and standard deviation of GA for preeclamptic and healthy pregnancies	122
Table 4.2. Biomarker with statistical significant differences between PE placenta and healthy controls.	130
Table 4.3. Statistically significant markers with their identities and average elution time in the total ion chromatogram	132

## LIST OF FIGURES

Figure 1.1. Abnormal placentation in PE.	7
Figure 1.2. Quadrupole time-of-flight mass spectrometer.	12
Figure 1.3. Schematic of Linear quadrupole.	14
Figure 1.4. Principle of operation for reflectron ion mirror ( $m_1$ : $m/z$ with higher velocity; $m_2$ : $m/z$ with lower velocity; $E_{kin}$ : Kinetic energy).	18
Figure 1.5. Tandem mass spectrometry of peptides and fragment ion nomenclature.	22
Figure 1.6. Structures of few classes of lipids. R represent fatty acid chain A) Phosphocholines B) Phosphoethanolamines C) Sphingomyelin D) Acylcarnitines	25
Figure 1.7. Molecular weight distribution of proteins in humans.	32
Figure 2.1. An overlay of 16 mass spectra in the region containing peptide $m/z$ 718.36 with its isotope envelope ( $z = +2$ ). Red: tissue collected from chorionic plate; blue: tissue collected from outer cotyledons (basal plate). This species was more abundant in the chorionic plate of placenta ( $p=0.007$ ).	57
Figure 2.2. Averaged MS2 spectra of a second differentially expressed peptide $m/z$ 808.82 ( $z = +2$ ) (mass accuracy of the precursor peak =27 ppm) and the MS fragment-ion calculator's prediction of b and y ions. This peptide was identified as a fragment of phosphorylated fibrinopeptide A.	62
Figure 2.3. Summed MS2 spectrum of a differentially expressed sodiated lysophosphatidylcholine ( $m/z$ 544.33, $z = +1$ ) (mass accuracy of the precursor peak =51), with its collision product ions and their proposed chemical structures or the proposed component lost with fragmentation. Mass accuracies of individual product ions having $m/z$	

values of 86.09, 104.1, 146.97, 184.06, 258.1, 339.26, 485.23 were 64 ppm, 59 pm, 68 ppm, 42 ppm, 37 ppm, 63 ppm, 53 ppm respectively. 65

Figure 2.4. Differential expression of peptide with m/z of 718.36 ( $z = +2$ ). A. This is a line plot of the abundance of the peptide in the basal versus the chorionic plate of each of the 12 replicates demonstrating the consistency of its differential expression. Each colored line represents a single specimen. B. This is a box and whisker plot of the same peptide and its mean abundance in the same two regions of the 12 placentas. 71

Figure 3.1. MS overlay and box-and-whisker plot for peptide m/z 827.78 ( $z=+6$ ) A. Overlay of 26 mass spectra in the region containing peptide m/z 827.78 ( $z=+6$ ) with its isotope envelope. Blue, placental explants under control conditions. Red, placental explants under hypoxic conditions. Species less abundant in the hypoxic placental explants. B. Box-and-whisker plot of peptide m/z 827.78 ( $z=+6$ ) 89

Figure 3.2. Scatterplot of Group Membership Based on the Statistical Model. The numbers, 1, 2, 3, and 4, correspond to the Controls, Hypoxia, Inflammatory Cytokines, and Hypoxia-Reoxygenation classes, respectively. The x, y, and z axes, which are not constrained to be orthogonal, represent the predicted probabilities from the lasso model for the Controls, Hypoxia, and Hypoxia-Reoxygenation treatment classes, respectively. 98

Figure 3.3. Venn diagram to represent the overlap in biomarkers between the three PE conditions applied on placental explants. 111

Figure 4.0.1. MS/MS spectra of identified acylcarnitine (m/z 426.35;  $z=+1$ ) 134

## LIST OF ABBREVIATIONS

µg/ml	Micrograms per microliter
µl	Microliters
2-DGE	Two-dimensional gel electrophoresis
ACN	Acetonitrile
ACN	Acetonitrile
Ar	Argon
AT <sub>1</sub> -AA	Angiotensin II type 1 receptor autoantibodies
AUC	Area under curve
CHCA	α-cyano-4-hydroxycinnamic acid
CI	Chemical ionization
CID	Collision induced dissociation
C-section	Caesarian
CT	Cytotrophoblasts
C-termini	Carbon termini
d.c.	Direct current
Da	Daltons
DHB	2,5-dihydroxybenzoic acid
DMEM	Dulbecco's modified eagle medium
E	Kinetic energy
ECD	Electron capture dissociation
EI	Electron ionization
ESI	Electrospray ionization
ETD	Electron transport dissociation
FbA	Fibrinopeptide A
FFPE	Formalin-fixed paraffin embedded
FTICR	Fourier transform ion cyclotron resonance
GA	Gestational age
GluFib	Glu-1-Fibrinopeptide
H/R	Hypoxia-reoxygenation
HCD	High collision dissociation
Hgb	Hemoglobin
HIF-2α	Hypoxia inducible factor-2α
HILIC	Hydrophilic interaction liquid chromatography
HMDB	Human Metabolome Database
HMW	High molecular weight
HPLC	High performance liquid chromatography
ICAT	Isotope-coded affinity tag
IEF	Isoelectric focussing
IR	Infrared
ITRAQ	Isobaric tags for relative and absolute quantitation
LASSO	Least absolute shrinkage and selection operator
LCM	Laser capture microdissection
LC-MS	Liquid chromatography-mass spectrometry
LLE	Liquid-liquid extraction

LMW	Low molecular weight
LOD	Limit of detection
LPC	Lysophosphocholine
m	Mass
m/z	Mass-to-charge
MALDI	Matrix-assisted laser desorption/ionization
MARS	Multiple affinity removal systems
MCP	Microchannel plate
MDA	Malondialdehyde
MS	Mass spectrometry
MS/MS	Tandem mass spectrometry
MudPIT	Multidimensional protein identification technology
N <sub>2</sub>	Nitrogen
Na	Sodium
nM	Nanomolars
NP	Non-polar
N-termini	Amino termini
PBS	Phosphate buffer saline
PC	Phosphatidylcholines
PEt	Phosphoethanolamines
PE	Preeclampsia
pg	Picograms
PMT	Photomultiplier tube
PS	Phosphoserine
Psi	Pounds per square inch
PTM	Post-translational modifications
Q-TOF	Quadrupole-time-of-flight
r.f.	Radiofrequency
ROS	Reactive oxygen species
RP-LC	Reversed phase liquid chromatography
rpm	Revolutions per minute
SDS-PAGE	Sodium dodecyl sulfate-polyacrylamide gel electrophoresis
sFlt-1	Soluble fms-like tyrosine kinase-I
SM	Sphingomyelin
ST	Syncytiotrophoblasts
STBM	Syncytiotrophoblast microvesicles
TIC	Total ion chromatogram
TMA	Trimethylamine
TNF $\alpha$	Tumor necrosis factor-alpha
UV	Ultraviolet
v	Velocity
V	Volts
v/v	Volume/volume
VEGF	Vascular endothelial growth factor
XIC	Extract ion chromatogram



# 1 Introduction

## 1.1 Preeclampsia

### 1.1.1 History

Headaches accompanied by heaviness and convulsions during pregnancy are considered bad. This was the first suggestion of preeclampsia (PE) made by Hippocrates in 400 BC.<sup>1</sup> In the late 1800s the theory of causation was believed to be the involvement of toxins. Differentiation of epileptic seizures from eclampsia, the extreme swelling in eclamptic women and the presence of protein in urine were described by *Bossier de Sauvages* in 1739, *Demaneuf* in 1797 and *Pierre Rayer* in 1840 respectively. After the invention of the mercury manometer in 1896, it was recognized that PE was a hypertensive disorder. Although PE is still referred as “disease of theories”,<sup>2</sup> recent advances have been made in understanding the pathophysiology of PE. This includes involvement of the mother’s placenta as an essential and perhaps the central feature in the pathogenesis of this disease.<sup>3</sup>

### 1.1.2 Definition of PE

The diagnosis of PE is based on the presence of *de novo* hypertension after 20 weeks gestation and proteinuria. The current guidelines are as follows:

Blood pressure: An elevated systolic blood pressure  $\geq 140$  mmHg and a diastolic pressure of  $\geq 90$  mmHg ( $\geq 160$  mmHg/110 mmHg is diagnostic of severe PE) on at least two readings, at least 4 hr apart.<sup>4</sup>

Proteinuria:  $\geq 300$  mg protein/24 hr urine

If symptoms of PE remain untreated, the disease can progress to eclampsia<sup>5</sup> defined as a grand mal seizure in pregnant women, not related to any preexisting neurologic condition.

### 1.1.3 Epidemiology of PE

Occurrence of PE varies worldwide. The incidence ranges from 2-10+ % around the globe.<sup>5</sup> The World Health Organization's estimate of PE incidence in developing countries is 7 times higher than the developed nations.<sup>5</sup> PE is the second leading cause of maternal deaths accounting for over 75,000 mothers<sup>6</sup> and claiming lives of over 500,000 infants.<sup>7</sup> As a consequence of PE, up to 12% of all newborns are severely growth restricted and one-fifth of them are born preterm.<sup>8</sup> Symptoms of PE resolve quickly after delivery of the baby in almost all cases.<sup>8</sup> Long term sequelae of PE remains under investigation, but include a higher risk of hypertension, stroke and ischemic heart disease for mothers.<sup>8</sup> Children born preterm or small in size have a higher risk of cerebral palsy.<sup>8</sup> Several risk factors are proposed in case of PE. For primigravidas, a family history of PE increases the risk of a severe PE by 4 fold.<sup>9</sup> In addition, it is also believed that a man who has fathered one preeclamptic pregnancy is more likely to father another pregnancy complicated by PE as well, even with a separate partner.<sup>10</sup> In comparison to multiparous women, nulliparous women are up to 3 times more likely to develop PE.<sup>10</sup> Several preexisting conditions like hypertension, diabetes mellitus can increase the risk of this disease.<sup>10</sup> Smoking is associated with a reduced risk of PE, although the adverse effects of smoking still outweigh the potential benefits during a pregnancy.<sup>10</sup>

The pathophysiology of PE remains poorly understood. It has been widely accepted that the onset of the disease process starts with impaired spiral artery remodeling, as a consequence

of inadequate trophoblast invasion.<sup>11</sup> Trophoblasts represent the outermost layer of the blastocyst. These cells form a major portion of the placenta providing nutrients to the embryo. In humans, on around the 8-9<sup>th</sup> day after conception the blastocyst with its trophoblast cells begins to invade the endometrium (Figure 1.1). This step is crucial for a healthy pregnancy.<sup>12</sup> Trophoblast cells are differentiated into undifferentiated cytotrophoblasts (CT) and highly differentiated syncytiotrophoblasts (ST).<sup>13</sup> ST are the cells in direct contact with the maternal blood and invade the endometrium (interstitial invasion) and its blood vessels (endovascular invasion). These cells thus play an important role in the remodeling of spiral arteries. Spiral arteries are responsible for providing blood supply to the endometrium during pregnancy.<sup>14</sup> These arteries, as a consequence of the invasion are converted from high-resistance blood vessels to low-resistance high flow arteries. This conversion ensures a sufficient amount of blood flow to meet the high metabolic demand of the fetal-placental unit during pregnancy. It is believed that PE starts as a consequence of an incomplete remodeling of the maternal spiral arteries causing reduced blood flow to the placenta (Figure 1.2).<sup>15</sup> This reduced blood flow has consequences, such as a hypoxic placenta and/or an increased state of placental oxidative stress.

#### 1.1.4 Conditions believed to be involved in the pathogenesis of PE:

Many abnormalities accompany established, clinically evident PE. However, far fewer features of the disease have been found to precede the maternal features of PE. Among these, a few have been documented in several studies making them better established and more accepted as early and likely contributory changes.<sup>16</sup> Among these abnormalities, those that are now considered to be etiologic or highly involved in the disease process are as follows:

#### 1.1.4.1 Hypoxia/ischemia of placenta

Hypoxia, in particular a hypoxic placenta is likely the most commonly proposed mediator of PE. Due to impaired spiral artery remodeling, blood flow to the placenta is reduced, leading to the placenta being deprived of oxygen (Figure 1.3). The hypoxic placenta is then believed to release vasoactive factors into the maternal circulation causing endothelial dysfunction and ultimately the symptoms of PE.<sup>17</sup> Proposed mediators include soluble fms-like tyrosine kinase-1 (sFlt-1), pro-inflammatory cytokines, and angiotensin II type 1 receptor autoantibodies (AT<sub>1</sub>-AA).<sup>17</sup> In addition, studies<sup>18</sup> have been conducted that show a higher expression of hypoxia inducible factor-2 $\alpha$  (HIF-2 $\alpha$ ) in preeclamptic placenta, which is a paracrine factor that regulates several pathways to respond to the oxygen environment to preserve cellular functions.<sup>18</sup>

#### 1.1.4.2 Oxidative stress

Oxidative stress can occur as a consequence of an imbalance between production of reactive oxygen species (ROS) and antioxidant defences. Oxidative stress of the placenta is believed to occur as a result of an intermittent supply of blood to placenta due to impaired spiral artery remodelling.<sup>19</sup> This hypoxia-reoxygenation causes placental oxidative stress, indicated by an increased concentration of malondialdehyde (MDA) in preeclamptic placenta, a product of ROS activity and a marker of lipid peroxidation.<sup>20</sup> A higher concentration of placental tumor necrosis factor- $\alpha$  (TNF- $\alpha$ ), a pro-inflammatory cytokine, has also been reported in response to increased ROS.<sup>20</sup> Increased secretion of this cytokine into the maternal circulation could lead to peroxidation of maternal lipids and in turn cause endothelial dysfunction.<sup>20</sup> Oxidative stress of placenta is also accompanied by a decreased expression of superoxide dismutase mRNA and protein expression potentially limiting its oxidant scavenging activity.<sup>21</sup> This reduction may also be linked to

an increase in apoptotic activity which can cause microvillous fragments from placenta to be released into the maternal circulation further leading to endothelial dysfunction and presumably symptoms of PE.<sup>22</sup>

#### 1.1.4.3 Angiogenic factors

There is substantial evidence for a dysregulation of pro-angiogenic and anti-angiogenic factors in many women with established PE and a suggestion of changes in circulating levels of these factors up to 5 weeks prior to PE in some women destined to develop the disease.<sup>23</sup>

Placental growth factor (PlGF) and vascular endothelial growth factor (VEGF) are pro-angiogenic factors essential for placental vascular development. It has been proposed that PE occurs due to an imbalance of these fundamental angiogenic factors.<sup>15</sup> Studies have demonstrated a decrease in free levels of PlGF and VEGF<sup>15</sup> and an increase in sFlt-1 in the circulation of women with PE<sup>24</sup> as compared to controls. Reduced amounts of pro-angiogenic factors may result in impaired spiral artery remodeling and thus lead to features of PE. A study conducted by Wang et al demonstrated a decreased invasiveness by CT in response to an increase in sFlt-1 in vitro.<sup>25</sup> sFlt-1 which is a splice variant of the VEGF receptor Flt-1, blocks the actions of both VEGF and PlGF by binding them in the circulation. This binding prevents the interaction of these mediators with their receptors, thus attenuating their angiogenic properties.<sup>15</sup>

#### 1.1.4.4 Cytokines

Among other factors thought to contribute to the pathogenesis of PE are increased levels of certain pro-inflammatory cytokines. Multiple studies have shown an increase in circulating

levels of this class of molecules in preeclamptic patients when compared to normotensive mothers.<sup>26</sup>

Other studies have shown an increase in the mRNA and protein expression of inflammatory cytokines in preeclamptic placentas.<sup>27</sup> This upregulation of cytokine production is thought to be caused by the focal regions of hypoxia that result from shallow vascular invasion during implantation. The hypoxic environment is sensed by HIF-alpha, which directly regulates the transcription of certain cytokines such as tumor necrosis factor  $\alpha$  (TNF $\alpha$ ). This finding has been confirmed by other studies in which elevated amounts of TNF $\alpha$  were generated when placental explants were placed in hypoxic conditions.<sup>28</sup>

Although these and many other abnormalities have been proposed as causes of PE, mechanistic involvement of any of these conditions has yet to be proved. Nevertheless, placental involvement is almost certain in the pathogenesis of PE.

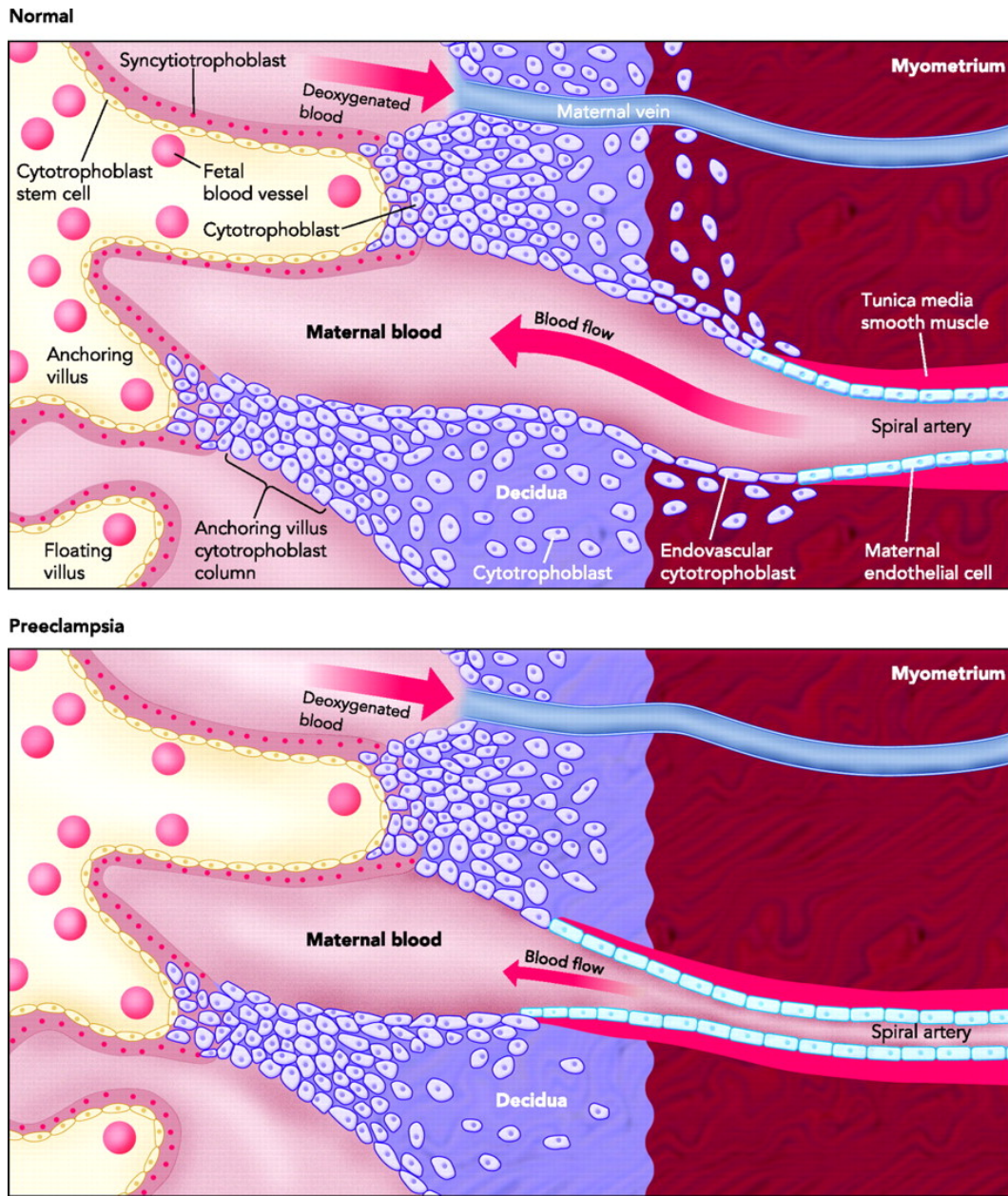

Figure 1.1. Abnormal placentation in PE. (Reprinted with permission from Wang, A.; Rana, S.; Karumanchi, S. A., Preeclampsia: the role of angiogenic factors in its pathogenesis. *Physiology (Bethesda)* 2009, 24, 147-58.)

### 1.1.5 The role of the placenta in PE

The placenta is the temporary organ that performs crucial functions in sustaining a successful pregnancy. It is responsible for the import of nutrients, exchange of gases and removal of waste products from the fetus. In addition, it synthesizes several peptides and synthetic hormones regulating many functions required for a healthy pregnancy. Symptoms of PE resolve rapidly after delivery which could either be due to the involvement of placenta or the fetus.<sup>19</sup> Placenta has been widely implicated in the pathogenesis of PE, but not the fetus. Moreover, PE has also been observed with a molar pregnancy.<sup>19</sup> A molar pregnancy is a condition, where the trophoblastic tissue supposed to become fetus develops into an abnormal growth or mass. Occurrence of PE in such circumstances indicates the involvement of the placenta and placental factors and not the fetus in the pathophysiology of the disease.<sup>19</sup>

## 1.2 Biological mass spectrometry (MS)

### 1.2.1 MS applications to complex biological specimens

A MS is a device that measures the mass-to-charge ( $m/z$ ) ratio of gas-phase ions. Application of MS to biological samples increased exponentially with the development of “soft ionization sources” such as Electrospray Ionization (ESI) and Matrix-Assisted Laser Desorption/Ionization (MALDI). Both of these ion sources convert analytes into gas-phase ions with minimum in-source fragmentation and produce  $[M + zH]^{z+}$  ions. This is in contrast to more conventionally used ionization techniques such as Chemical Ionization (CI) and Electron Ionization or Electron Impact (EI) which cause a higher degree of in-source fragmentation.<sup>29</sup>



### 1.2.1.1 ESI

ESI for the analysis of biological macromolecules was introduced by Fenn and co-workers in 1984. In this technique, a volatile liquid containing the biomolecules of interest as well as containing a weak volatile acid is introduced at a flow rate ranging from one to several hundred  $\mu\text{l}/\text{min}$  through a very narrow capillary ( $\sim 0.2$  mm o.d and  $\sim 0.1$  mm i.d) made of stainless steel or quartz silica. This capillary is maintained at a high voltage (2-6 kV) which causes aerosol formation in the form of a Taylor cone with production of charged droplets.<sup>30</sup> Each charged droplet initially is in the micrometer range and positively charged due to the presence of  $\text{H}^+$  and other cations such as  $\text{Na}^+$  and  $\text{K}^+$ . Droplet formation is followed by solvent evaporation by a coaxial flow of heated sheath gas (e.g. dry nitrogen gas). This heating causes evaporation of the solvent from the charged droplets. As a consequence, the charge density keeps increasing and approaches the Rayleigh limit where the surface tension of the liquid droplet is balanced by the coulombic repulsion.<sup>29</sup> Increasing solvent evaporation and consequent repulsive forces causes a coulombic explosion and release of progeny droplets.<sup>31</sup> This process continues until gas phase ions are formed from these droplets. These ions are then directed to the mass analyzer towards an oppositely charged plate.

### 1.2.1.2 MALDI

In MALDI the analytes are co-crystallized with a suitable matrix molecule. Examples of organic matrices include 2,5-dihydroxybenzoic acid (DHB) and  $\alpha$ -cyano-4-hydroxycinnamic acid (CHCA). These matrices have a very strong absorption in the ultraviolet (UV) or infrared (IR) range but remote from protein UV absorbances. The laser (e.g. nitrogen laser) is fired on the matrix which absorbs the energy of the laser light and heats the matrix molecules very rapidly,

causing the specimen to be simultaneously desorbed and ionized. The mechanism of ionization for MALDI is still debatable, but it is believed<sup>32</sup> that the desorbed matrix molecules transfer a proton to the analyte thus charging it, typically with one positive charge per analyte molecule. These charged analytes are then accelerated into the vacuum region of the mass analyzer and directed into the MS.<sup>32</sup>

A potential advantage of ESI over MALDI, which more commonly produces  $[M+H]^{1+}$  species, is the ability of ESI to produce multiply charged species. This is especially important in the field of proteomics as large proteins can be multiply charged and can fall in the mass range of the mass analyzers such as quadrupole-time-of-flight (Q-TOF), commonly used to study proteins and peptides.

### 1.2.2 Mass analyzers for biomolecules

Mass spectrometers (MS) commonly used for the analysis of biomolecules are Quadrupole MS, Time-of-flight MS, Quadrupole ion trap MS, Orbitrap MS, and Fourier transform ion cyclotron resonance (FTICR) MS.

For my research, the mass analyzer used was a tandem MS, a hybrid of two mass analyzers: a quadrupole coupled to a time-of-flight MS (Q-TOF).

In a QqTOF-MS instrument there are several sectors including a mass-resolving quadrupole (Q), a radiofrequency (r.f.) quadrupole (q), and the mass analyzer (TOF). Most of the commercially available QqTOFs have an additional  $Q_0$  which can be a hexapole or octopole and is operated in a r.f. only mode to act as an ion focusing guide.<sup>33</sup> So for QqTOF-MS, the configuration is comparable to a triple quadrupole MS configuration, except the final quadrupole is replaced by a TOF detector (Figure 1.4). Replacement by a TOF mass analyzer provides certain

advantages such as 1) higher resolution, achieved by ion mirrors and a delayed extraction process, 2) higher mass accuracy, 3) and parallel recording of all ions.

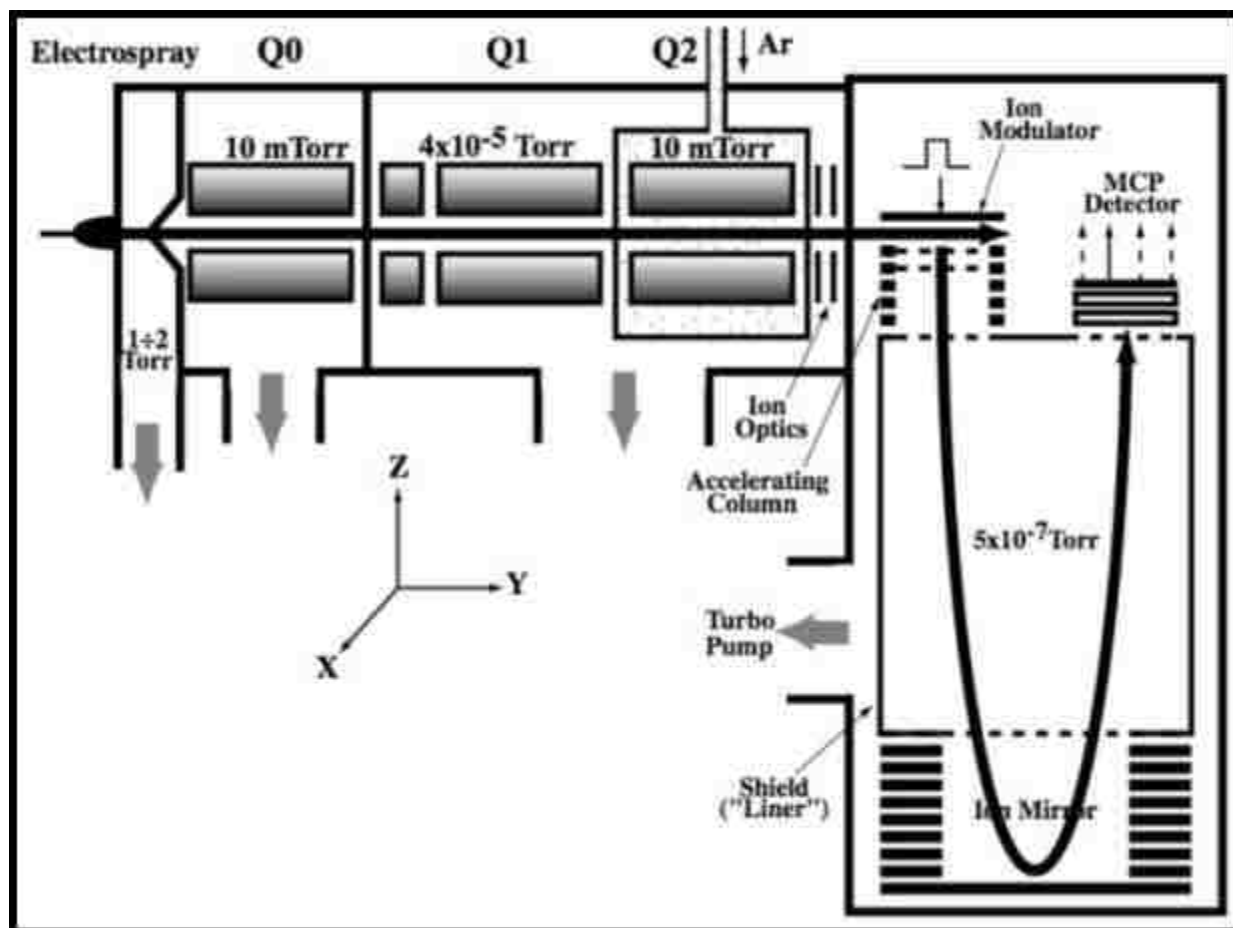
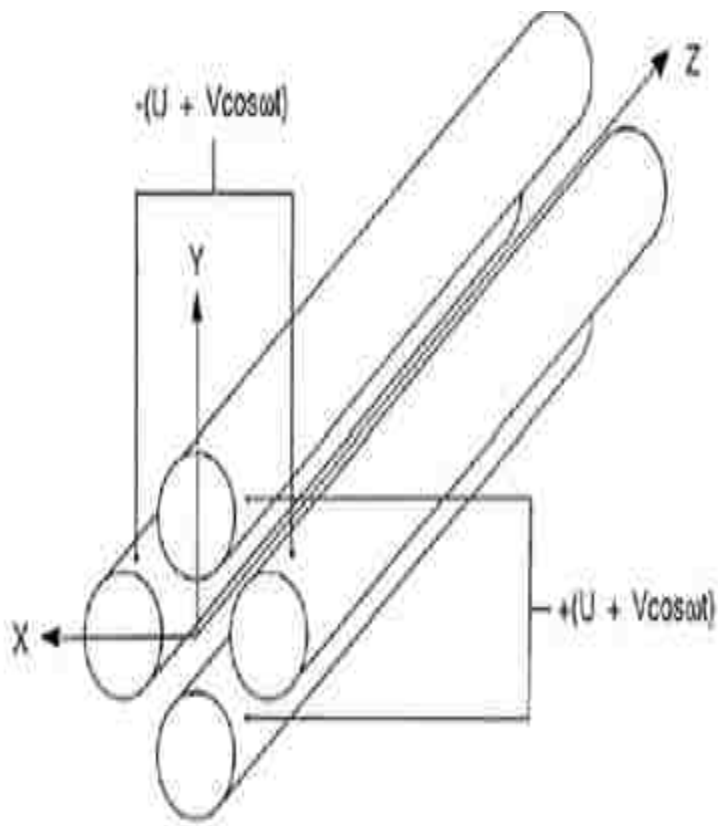

Figure 1.2. Quadrupole time-of-flight mass spectrometer. (Reprinted with permission from Chernushevich, Igor V., Alexander V. Loboda, and Bruce A. Thomsen from. T "An introduction to quadrupole-time-of-flight mass spectrometry." *Journal of Mass Spectrometry* 36.8 (2001): 849-865.)

### 1.2.3 Quadrupole MS

A quadrupole MS consists of four parallel hyperbolically or cylindrically shaped metal rods at equal distances from each other. These electrodes extend in the z direction and are arranged in a square configuration. Each set of diagonal rods carry identical charge while the other set carries the opposite charge (Figure 1.5). As an ion enters in z direction, it gets attracted by the rod with an opposite potential, since an r.f. (radio frequency) voltage is applied between diagonal rods, the sign of the potential changes and thus the ion forces attraction and repulsion in x and y direction. For the quadrupole mass filter a d.c. (direct current) voltage is superimposed on the applied r.f voltage. For a given ratio of r.f and d.c voltages, only a certain m/z or a certain range of m/z's will have stable trajectory between the quadrupole region to pass through it.<sup>33</sup>



**Figure 1.3. Schematic of Linear quadrupole. (Reprinted with permission from Gross, J. Mass Spectrometry, 2nd ed.; Springer, 2011; pp 147)**

The 'q' in QqTOF act as a collision cell to cause fragmentation. This technique is referred as tandem mass spectrometry (MS/MS) (Figure 1.6). The collision cell works in the r.f. only mode to transmit all m/z values with stable trajectories. In MS/MS mode, Q1 works as a mass filter and transmits only a desired parent or precursor ion with the pre-determined m/z value. This parent or precursor enters the collision cell or the 'q' sector where it undergoes collision-induced dissociation (CID) or breakage. CID is a process where the precursor or parent of interest is accelerated with high energy (generally between 15-200 eV) and collides with a neutral gas, e.g. nitrogen or argon. As a consequence of this collision some of the kinetic energy of the molecule is converted into internal energy and causes bond breaking and fragmentation of the targeted ion. For proteins and peptides the site of cleavage is known for CID and is discussed in more detail later in this dissertation. The first set of fragments produced in MS/MS is also known as the MS<sup>2</sup> spectrum and one can perform additional fragmentation of a selected MS<sup>2</sup> product to generate MS<sup>3</sup> products and so on using advanced instruments such as Orbitrap. During MS<sup>1</sup> conditions where no MS/MS is desired, parameters are similar, only the collision energy is kept below 10 eV to prevent fragmentation.<sup>33</sup>

#### 1.2.4 TOF

The TOF MS acts as mass analyzer where the m/z of the analyte ion is determined by the flight time in a field-free drift tube of a determined length. As the ions leave the collision cell, they are accelerated again, in a parallel beam focused by the ion optics and reach the ion modulator/ion pulser of the TOF. At this point a high voltage pulse is applied which forces the ions to move perpendicularly and enter the field-free flight tube. At the end of this flight tube is an elec-

trostatic ion mirror which improves mass resolution and sends back ions from the ion pulser toward the detector. The detector is made up of a microchannel plate (MCP), scintillator and a photomultiplier tube (PMT). The first stage of the MCP is a thin plate made up of multiple microscopic channels with approximately 10 micrometer diameters. As each analyte ion hits the MCP plate, a pulse of approximately 10 electrons are produced which then hit the scintillator resulting in photon emission. These photons are focused to the PMT which amplifies them producing an electrical signal proportional to the number of photons.<sup>33</sup>

Time-of-flight for each ion is dependent on its mass. As a result, each ion has a unique flight time. Velocity of a given ion is determined by using the following formula:  $v = \sqrt{(2E/m)}$ , where E stands for a given kinetic energy, m for mass and v for velocity. Thus, according to the equation lighter ions will have a higher velocity and heavier ions, a lower velocity. This causes their separation in the field-free flight tube.<sup>33</sup>

#### 1.2.4.1 Approaches developed to increase the resolution of TOF instruments

Delayed extraction:

During certain ionization methods like MALDI, there is a significant energy spread of the produced ions causing a significant temporal distribution and thus loss of resolution. To address this issue, a process known as delayed extraction is employed where a delay occurs between generation and acceleration of ions. Due to the pulsed nature of MALDI, ions with the same masses move with different velocities. As can be seen in Figure 1.7, the ion moving with higher velocity (red) experiences a lesser extraction voltage between target and extraction plate (+V) as compared to the ion moving slower (blue). The slowest ion thus receives maximum energy therefore compensating for temporal distribution and improving the resolution.<sup>3</sup>



### Reflectron/ion mirror

A reflectron consists of decreasing electric field and is located behind the field free region of the TOF tube. These mirrors are stacks of electrodes with increasing voltages, responsible for compensating for the difference in velocities, i.e. kinetic energies, and thus improving resolution. Ions with higher velocities penetrate deeper into the mirror assembly until their K.E becomes zero. Ions with more K.E move deeper and thus spend more time in the reflectron than an ion of the same mass but with low velocity, this corrects for the difference in velocities thereby increasing the resolution (Figure 1.8).<sup>35</sup>

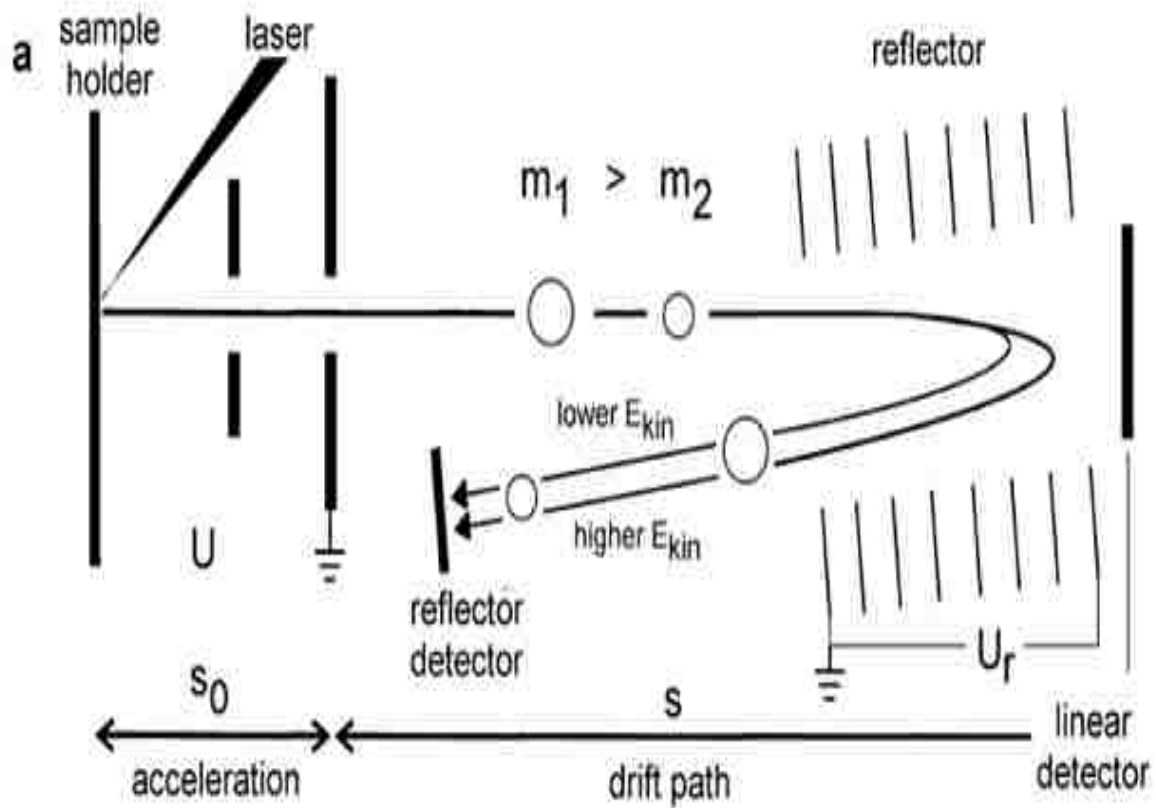

Figure 1.4. Principle of operation for reflectron ion mirror ( $m_1$ :  $m/z$  with higher velocity;  $m_2$ :  $m/z$  with lower velocity;  $E_{kin}$ : Kinetic energy). (Reprinted with permission from Gross, J. Mass Spectrometry, 2nd ed.; Springer: Germany, 2011; pp 126)

### 1.3 Proteomics

The term “proteomics” was first coined in 1995 and was defined as “the large-scale characterization of the entire protein complement of a cell line, tissue, or organism”.<sup>36</sup> The emerging field of proteomics has a wide range of applications ranging from discovering biomarkers for various diseases to finding new targets for drug therapy. The phenotype of a cell is more closely represented by its proteome as compared to its genome. While transcriptional studies yield useful information about gene expression patterns in cells, proteomic studies may provide important advantages.<sup>37</sup> Proteins themselves are the direct participants in the cellular processes of both healthy and diseased tissues; indeed, recent studies have indicated that mRNA levels have only moderate power to predict protein concentrations. In fact, it is estimated that only about 40% of protein expression levels can be explained by mRNA expression levels.<sup>37</sup> Hence, proteomic methods, which more directly measure protein abundance, likely provide a clearer picture of the pathophysiology of disease conditions such as PE. In addition, most transcriptomic technologies are incapable of predicting splice variants arising from the same gene, and none can predict post-transcriptional modifications that may affect the function of a protein.<sup>38</sup> These limitations prevent mRNA studies from investigating important changes involved in various diseases and argue for more extensive proteomic studies in cells and tissue.

Proteomics has been a challenging field considering the dynamic range of protein concentrations in an organism. For example, dynamic range of protein concentration in human serum is approximately 10 orders of magnitude.<sup>39</sup> Current technologies available cannot address this issue and analyze the complete proteome of a cell or a tissue.

### 1.3.1 Pre-separation before MS

Due to the complexity of biological samples and the wide dynamic range of protein concentrations, a pre-separation step is usually employed before introducing the samples into the mass spectrometer. The two most commonly used approaches to achieve pre-separation are 1) Two-dimensional gel electrophoresis (2-DGE) and 2) Reversed phase liquid chromatography (RP-LC).<sup>40</sup> 2-DGE uses isoelectric focusing (IEF) in the first dimension which separates the proteins based on their isoelectric point and by molecular weight in second dimension using sodium dodecyl polyacrylamide gel electrophoresis (SDS-PAGE). Each spot on the gel represents one protein which can then be cut out of the gel and digested using enzymes such as trypsin. This digestion yields a defined set of smaller peptides from the parent protein which are then analyzed using a suitable mass spectrometer.<sup>40</sup> The second approach uses a reversed phase/hydrophobic column to separate protein mixtures based on the differences in the hydrophobicities of individual proteins. This is currently a more commonly used approach as it has several advantages over 2-DGE such as better separation of a broad range of molecules, better sensitivity, easier operation and more compatible hyphenation with the mass spectrometers. Reversed phase columns commonly used are: C-18 (18-Carbon chain), C-8 (8-Carbon chain) and C-4 (4-Carbon chain). The longer the carbon chain, the more hydrophobic is the column.

Structural elucidation of proteins is extremely important in order to gain more information on that species. Protein sequencing is the process of determining the order of amino acids beginning from the N-termini (amino termini) to the C-termini (carboxy termini). In earlier days, sequencing was achieved by performing Edman degradation to identify N-terminal amino acid sequences. With the recent advances in MS-based techniques and increasing computing power, sequencing by Edman degradation has been replaced by MS-MS sequencing.

The QqTOF-MS most often uses CID as the ion activation/fragmentation method to sequence and identify proteins and peptides of interest. As described earlier, collisions break the most labile bond which in case of proteins and peptides is the amide bond, (-CO-NH-). As a consequence, CID yields b- and y-ion series which is represented in Figure 1.9. The b-ions represent the amino terminal of the protein, while the y-ion series represent the peptides starting at the carboxy terminus. Different collision energies can be required to provide a more complete and informative MS/MS spectra. Spectra obtained from all these collision energies can then be averaged using the MS system's software and this averaged spectra can then be submitted to search engines like MASCOT, SEQUEST, Spectrum Mill to finally determine the identity of the target parent protein or peptide.<sup>41</sup>

There are instances when none of the protein search engines will provide a match for the identification. In such situations, a technique known as *de novo* sequencing is applied. This is a process of determining the order of amino acids in the protein without the help of a database. *De novo* sequencing involves determining the N-termini or the C-termini and moving from there to establish the amino acid sequence based on the differences in the masses between b-series and/or y-series peaks. This is a challenging and a time consuming approach, especially for high charged state, post-translationally modified proteins/peptides.<sup>42</sup>

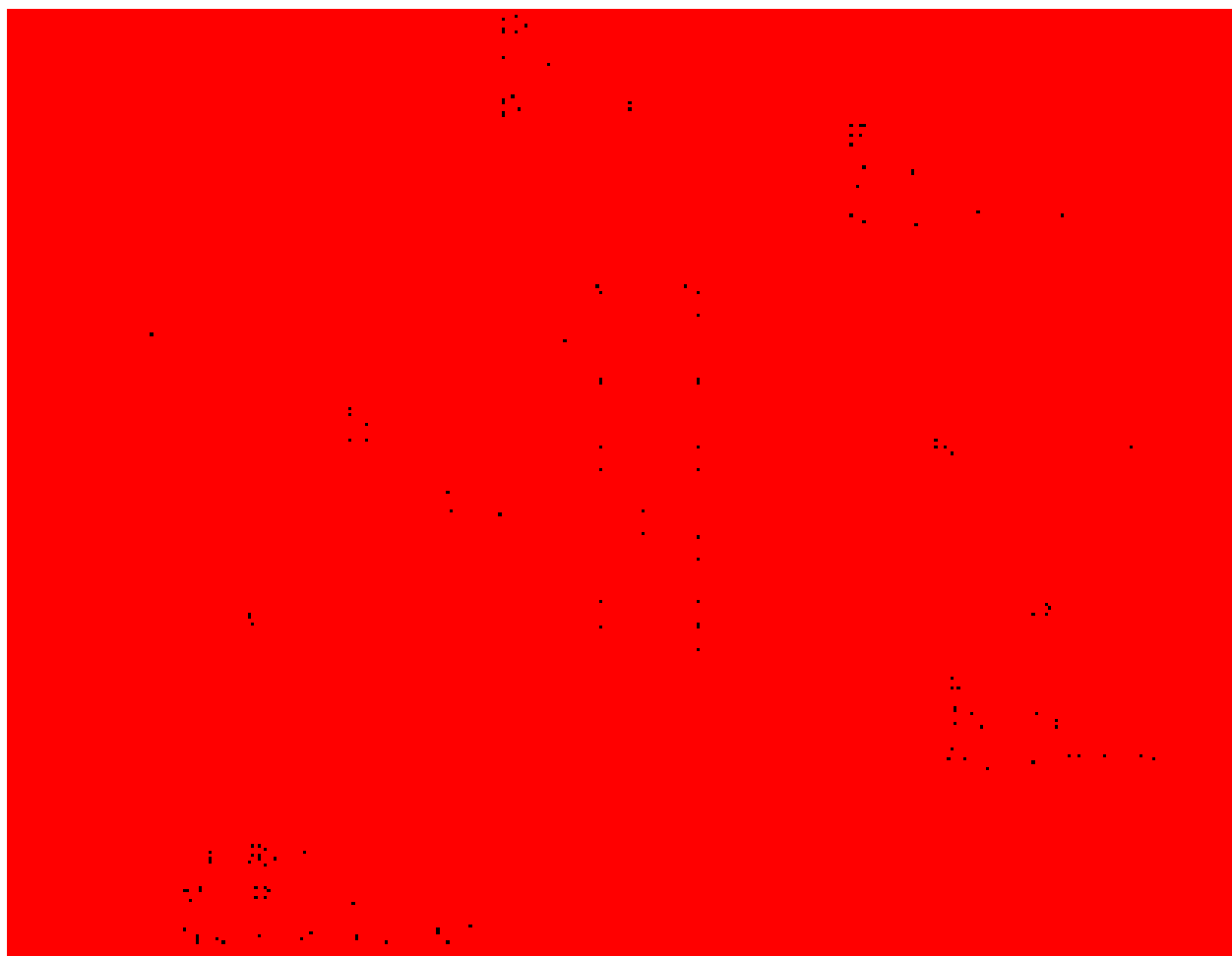

**Figure 1.5. Tandem mass spectrometry of peptides and fragment ion nomenclature** (Reprinted with permission from Zhurov, K. O.; Fornelli, L.; Wodrich, M. D.; Laskay, U. A.; Tsybin, Y. O., Principles of electron capture and transfer dissociation mass spectrometry applied to peptide and protein structure analysis. *Chemical Society reviews* 2013, 42 (12), 5014-30.

## 1.4 Lipidomics

Lipidomics is a relatively new field of study and was first reported by Han and Gross in 2003. It has been defined as “the full characterization of lipid molecular species and of their biological roles with respect to expression of proteins involved in lipid metabolism and function, including gene regulation”.<sup>43</sup> Lipids have important cellular functions, mostly energy storage, structural stability and cellular signaling.<sup>44</sup>

Lipid analysis, similar to proteomics can be broken down into following components: sample extraction, MS data acquisition and data analysis.

Since lipids form a diverse group of molecules with varying polarities and structures, a sample extraction approach which can extract this wide range is desirable. The most common way of extracting lipids has been by liquid-liquid extraction (LLE) using the Bligh and Dyer method. This approach uses a 1:2 v/v chloroform:methanol mixture which allows the more non-polar lipids to be extracted into the chloroform and the relatively polar ones into the methanol present.<sup>45</sup> Another approach to study lipids is by performing organic solvent precipitation with acetonitrile (ACN) or methanol. The limitation of this approach is that it extracts only a small range of lipid classes. For example this would include some glycerophospholipids like phosphatidylcholines (PC) and phosphoethanolamines (PEt) (Figure 1.10).<sup>45</sup>

Data acquisition of extracted lipids can be performed by either: 1) Direct injection into the MS 2) Liquid chromatography-mass spectrometry (LC-MS) analysis.

Direct injection is a simple technique which allows for faster analysis and detection of several lipid classes in a single MS run. This technique has some shortcomings such as determination of isobaric species, significant numbers of overlapping peaks and ion-suppression from

the presence of readily ionizable lipids. LC-MS on the other hand minimizes some of these effects. Columns commonly used for studying lipids by LC-MS are reversed phase columns separating lipids based on their hydrophobicities, which mostly depends on the number of carbons. Other less commonly used columns are normal phase columns (NP) and hydrophilic interaction LC (HILIC) both separating lipids based on their hydrophilic functional groups, mainly residing in their headgroups.<sup>45</sup> For ionization of lipid compounds through ESI, both the positive and negative ion mode can be used to target different classes of lipids for MS analysis. Structural elucidation of lipid classes can be challenging owing to the lack of knowledge and information regarding their fragmentation mechanisms and limited *in-silico* MS/MS databases. The process of lipid identification is very similar to *de novo* sequencing of proteins and peptides. CID is the most common way to break a lipid molecule in the collision cell. Certain lipid classes have predictable MS/MS spectra and thus can be identified based on signature peaks or specific neutral losses. For example PC's MS/MS spectrum shows a peak at  $m/z$  184.06 produced due to the headgroup phosphocholine while PE have an abundant peak at the neutral loss of 141.01 due to loss of the phosphoethanolamine headgroup. There are several databases which can help in the identification of lipid classes, but no single database is complete. LIPID MAPS, METLIN, HMDB (Human Metabolome Database) are some of the commonly used databases for such predictions.



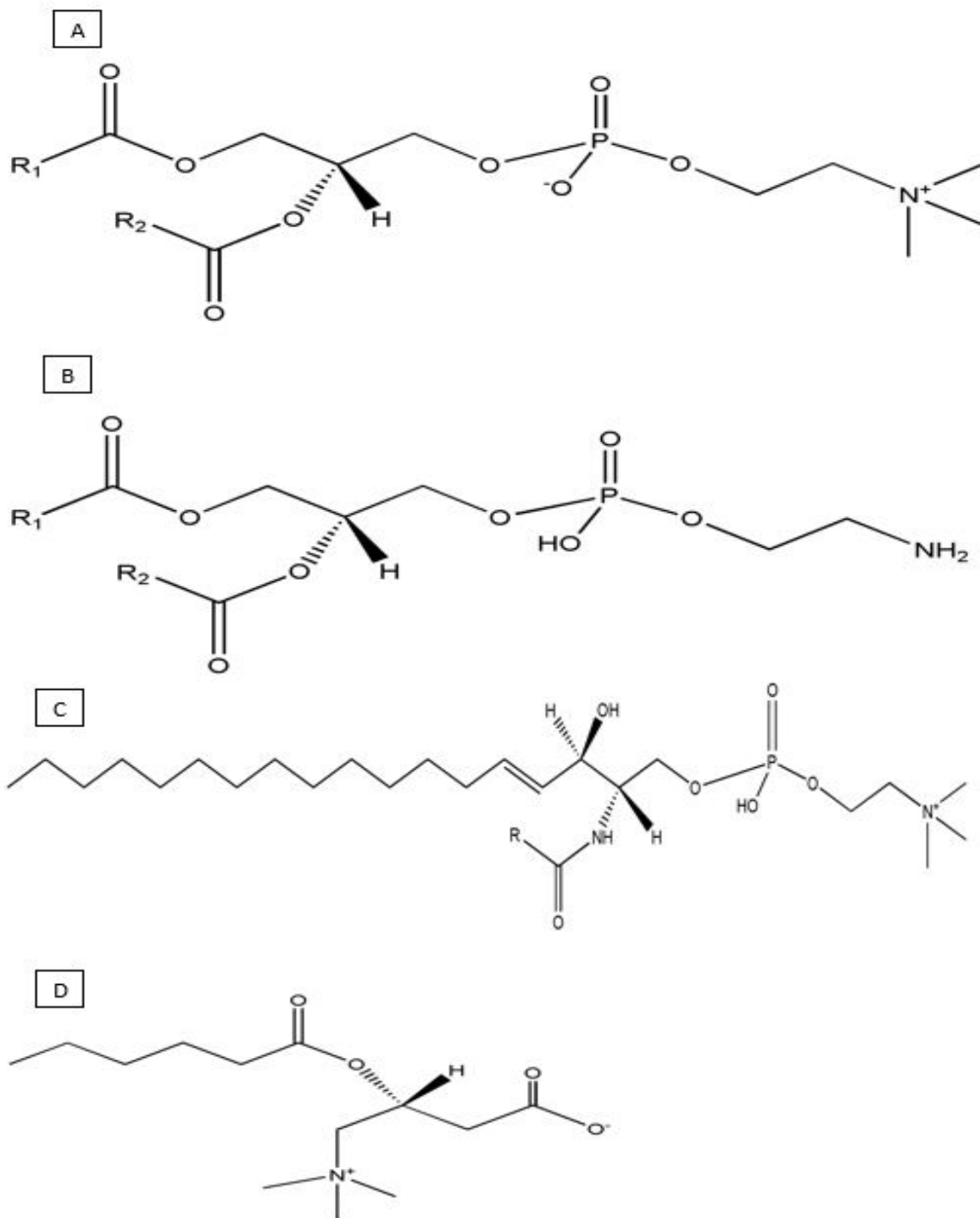

**Figure 1.6. Structures of few classes of lipids. R represent fatty acid chain A) Phosphocholines B) Phosphoethanolamines C) Sphingomyelin D) Acylcarnitines**

## 1.5 Tissue analysis

Tissue analysis has several inherited advantages over other biological matrices. Several orders of magnitude higher concentrations of tissue specific biomolecules and a closer representation of molecules in their native surroundings are some of these advantages.<sup>46</sup> Challenges encountered while performing tissue analysis are tissue heterogeneity (overlap of different cellular types),<sup>47</sup> limited tissue availability in fresh form or a small amount of tissue not sufficient to perform the study. Some tissues are difficult to access and may limit studies to animals and may require sacrifice of the animal to obtain tissue preventing serial sampling. The most common approach for tissue analysis is tissue homogenization which involves grinding or cutting a part or a whole tissue using different techniques like ball mill homogenizer, a mortar and pestle, a blender, etc. Homogenization does not solve the problem of cellular heterogeneity. To address this, researchers use laser capture microdissection (LCM) to target a specific cell population.<sup>47</sup> Imaging techniques such as MALDI imaging have been attempted to study the protein repertoire of intact tissues. These techniques are well-suited for studies requiring analysis of biomolecules in their native architecture.<sup>48</sup> MS remains the most useful technique to study biomolecules from tissue samples processed using some of the described approaches. Preparation of formalin-fixed paraffin embedded (FFPE) tissue is the traditional way to preserve pathological and clinical specimens for long periods of time at room temperature. This technique crosslinks proteins thus rendering their analysis very challenging using current analytical platforms especially MS,<sup>49</sup> although with the help of recent developments, it has become feasible to analyze proteins from FFPE tissues using MS based techniques.<sup>49</sup> However, it is recognized that such studies can only be qualitative and will typically be limited in the range of proteins accessed.

Preeclampsia (PE) is proposed to be a disease of placenta. Hence, I will focus more on placenta as a tissue for analysis of biomolecules using MS based tools.

### 1.5.1 Placental analysis

#### 1.5.1.1 Placental proteomics

Placenta is a vital organ that mediates selective transfer of solutes and gases from the mother to her growing fetus. It is known to perform a vast number of functions for maintaining a healthy pregnancy, and this is supported by the fact that more than 20,000 DNA sequences are expressed by a human placenta.<sup>50</sup> Thus, exploring the protein expression patterns of such a vital organ may give deep insights into the functions of placenta and shed light on placental diseases such as PE.

Placenta is a highly complex organ exhibiting significant anatomical variation.<sup>50</sup> Placental proteomics is in its infancy owing to the complexity of the organ and lack of available protein isolation protocols. Several studies have been performed to investigate the proteome and sub-proteome of placenta and its cells. J.M Robinson et al. in their review on placental proteomics mention two approaches that can provide useful information about the placental proteome.<sup>51</sup> The first one referred to as ‘parallel profiling’ is a technique in which a common fractionation step is used to isolate proteins and look for differences in the protein expression patterns between the comparison groups (e.g. cases vs. controls). This approach has provided the most useful information in terms of differentially expressed proteins in any diseased state when compared to nor-

mal condition. The second one focuses more on a defined sub-proteome of placenta. Here, protein profile of an enriched cellular fraction of the organ is established to dig deeper into functions of placenta. I will now briefly discuss these approaches.

### Parallel profiling

Parallel profiling is a comparison based approach which has the advantage of providing a broader coverage of proteomic information. A substantial amount of research has been conducted to compare the placental proteome of a normal placenta to a diseased one using the concept of parallel profiling. Examples include a study conducted by Magnus and Stefan et al. to examine differences in proteins between preeclamptic and normal placentae.<sup>52</sup> They found an accumulation of apolipoprotein A1 in preeclamptic placenta, indicating a role of this protein in pathogenesis of this disease. In another study with placenta as the target tissue, it was shown that an increased amount of dynactin p-50 may be involved in the pathophysiology of PE. This was confirmed by the presence of higher amounts of anti-dynactin p-50 in the serum of preeclamptic mothers.<sup>53</sup> Both these studies as well as several other studies of the placental proteome have used 2-DGE as the method to separate proteins before trypsin digestion and MALDI MS. A more 'global' proteomics study was performed by Wang et al. in which a homogenate of placental tissues was submitted to LC/MS/MS and 171 proteins were found to be differentially expressed between normal healthy placenta and preeclamptic placenta. 147 proteins were found to be down-regulated while 24 proteins showed a higher expression in PE placentas. Examples of these proteins included endoglin, ceruloplasmin, mitochondrial superoxide dismutase and transforming growth factor beta.<sup>54</sup> All the above mentioned studies were limited to abundant proteins using bottom-up approaches.

## Sub-proteome studies

As mentioned above, a second approach to carry out a proteomics study on placenta is to isolate a sub-cellular fraction from the organ and extract proteins. Due to the ‘dynamic range problem’ identification of the entire placental proteome becomes a challenging task. Anatomical variations in placenta make this problem even worse. An alternative approach to reduce this problem is to identify proteins in a defined sub-cellular fraction. This approach also increases the probability of identifying low copy numbers, which fall below the detection limit of conventional techniques.

Before getting deeper into the sub-proteome studies done to date, it becomes important to know about the highly specialized cellular structures of human placenta, including the CT and ST. The trophoblast cells, upon contact with uterine walls differentiate into CT. These cells then differentiate into a highly specialized network of cells called ST, in which several cells fuse to form a single cell or a multi-nucleated syncytium housed within a single plasma membrane.<sup>55</sup> This epithelial structure forms the interface between maternal blood and placenta, and is considered to be the most important element in the selective transfer of substances across placenta to the fetus. Due to its importance in pregnancy, many attempts have been made to enrich this portion of placenta and explore its protein repertoire. A study conducted by Epiney et al. studied proteins secreted from cytotrophoblast cells from both normal and preeclamptic placenta. A label-free approach was used to find 21 proteins with differential expression between the comparison groups.<sup>56</sup> In another study, a relatively new approach LCM was used to isolate trophoblastic cells from preeclamptic and normal placental samples. This group found that 31 of the 70 altered

proteins were downregulated in preeclamptic placenta while the remaining 39 were upregulated.<sup>57</sup> Both of these techniques used enzymatic digestion to perform bottom-up proteomics using LC/MS platforms.

#### 1.5.1.2 Placental lipidomics

Lipidomics is a relatively new technique and placental lipidomics even newer. Only a handful of studies have been published to study the altered lipidome in preeclampsia using placenta as the study model. Henri et al. found an altered lipidome in preeclamptic placenta as compared to controls.<sup>58</sup> Placenta obtained from both the groups were homogenized and resuspended in water, lipids from this sample were extracted using the Bligh-Dyer protocol and were analyzed by MALDI/TOF-TOF. Phosphoserine (PS) followed by macrolides/polyketides were the most prevalent class of molecules with increased abundance in preeclamptic placenta when compared to controls. Another lipidomics study performed by Baig et al. investigated the lipidome of placental syncytiotrophoblast microvesicles (STBM) of preeclamptic placenta. This approach also used the Bligh-Dyer methodology followed by LC/MS. Approximately 200 lipids were quantified in STBM. According to this study, the major class of lipids observed in STBM were sphingomyelins (SM) which were upregulated in the preeclampsia group.<sup>59</sup>

#### 1.6 Importance of the LMW biomolecules and approaches to MS interrogation of smaller biomolecules

Most of the proteomics studies discussed above were performed using two 2-DGE to analyze proteins initially. Although it represents the most commonly used technique, 2-DGE is bi-

ased towards the identification of highly abundant, higher molecular weight proteins. LMW proteins are important participants in several biological processes such as ribosome formation, cellular signaling and stress adaptation. This fraction of the proteome has been identified as having important regulatory compounds such as cytokines, peptide hormones and chemokines. It is believed that 50% of the human proteome is composed of proteins below 26.5 kDa (Figure1.11).<sup>64</sup>

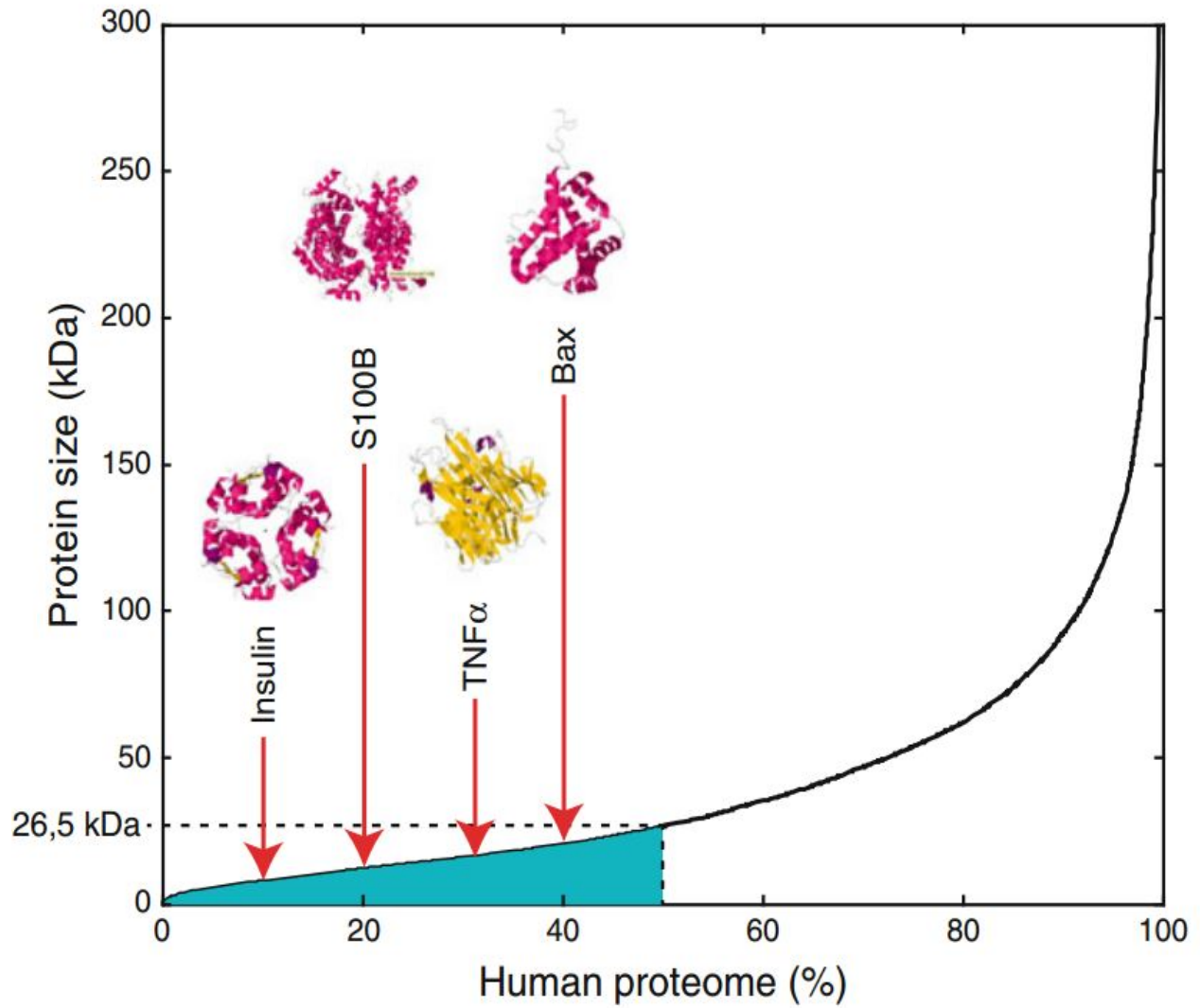

**Figure 1.7. Molecular weight distribution of proteins in humans. (Reprinted with permission from Bäckvall, H.; Lehtiö, J. *The Low Molecular Weight Proteome: Methods and Protocols*,; Springer: New York, 2013)**



LMW proteins despite their importance in the pathophysiology of various biological processes are underrepresented in proteomic studies owing to the very few approaches designed to isolate and focus on them. 2-DGE has a low sensitivity and usefulness for this fraction of the proteome as these small proteins have a tendency to stain poorly and migrate out of the gel easily.<sup>64</sup> Removal of abundant proteins makes the analysis of LMW species more feasible, especially if one is using MS based techniques. Some obvious advantages of protein depletion are narrowing of the wide dynamic range of human proteome and minimizing problems associated with ion suppression.

Several techniques have been used to deplete abundant, high MW proteins from biological matrices.

One of the techniques uses an immunodepletion affinity column to deplete the most abundant proteins from samples e.g. plasma. Some of these columns are named 'Multiple affinity removal systems' (MARS) which remove the 7 most abundant proteins, the 'MARS-7' column which removes the 14 most abundant proteins, the ProteoPrep20 column which removes the 20 most abundant proteins.<sup>60</sup> These columns use a mixture of antibodies against the most abundant proteins in plasma/serum samples to capture and retain those proteins thus reducing sample complexity and eliminating the most highly abundant species reducing ion suppression.<sup>61</sup> One limitation of using an affinity-based column is that the many LMW proteins/peptides carried by big proteins such as albumin cannot be studied as they are lost with the carrier proteins in this process as well.

Another approach to reduce the dynamic range problem and deplete abundant proteins is by performing centrifugal ultrafiltration. This technique can involve using different solvents to release the bound small proteins/peptides from carrier protein,<sup>62</sup> but other studies have shown

that approach using acetonitrile (ACN) as the organic solvent provides a more extensive in-depth analysis of the LMW proteome from serum samples.<sup>63</sup>

Organic solvent precipitation has been used traditionally to precipitate abundant large proteins. ACN is the most common solvent employed, which has been shown to precipitate most of the HMW proteins while releasing the LMW peptides and other species from carrier proteins including some classes of lipids. As a consequence the dynamic range becomes smaller and many more LMW species are available to investigate because ion-suppression has been minimized in MS analysis.

## 1.7 Layout of the dissertation

This dissertation is divided into 5 chapters. Chapters (2-4) involve working with human placenta, starting from development and optimization of a tissue proteomic approach to studying placentae cultured under preeclamptic conditions as well as the ones collected from actual preeclamptic pregnancies. Chapter 5 concludes the dissertation with a brief discussion on potential pitfalls as well as future prospects of this study.

Chapter 2 describes an initial study conducted to optimize a tissue proteomics approach to investigate differences in biomolecules between two regions of human placenta collected from healthy pregnancies. Chapter 3 details work on studying the differences in peptides and lipids in healthy human placental explants maintained in an environment simulating proposed preeclamptic conditions mainly hypoxia, oxidative stress and proinflammatory cytokines. In chapter 4 a follow-up study was conducted to study all the altered biomolecules in placentae under preeclamptic conditions in actual preeclamptic placentae and evaluate their statistical significance by comparing them with controls.

## 1.8 References

1. Bell, M. J., A Historical Overview of Preeclampsia-Eclampsia. *J. Obstet. Gynecol. Neonatal Nurs.* **2010**, *39* (5), 510-518.
2. Adu-Bonsaffoh, K.; Antwi, D. A.; Obed, S. A.; Gyan, B., Nitric oxide dysregulation in the pathogenesis of preeclampsia among Ghanaian women. *Integr. Blood Press. Control* **2015**, *8*, 1-6.
3. Singh, H. J., Pre-Eclampsia: Is It All In The Placenta? *Malays. J. Med. Sci.* **2009**, *16* (1), 7-15.
4. Brown, M. A.; Lindheimer, M. D.; de Swiet, M.; Assche, A. V.; Moutquin, J.-M., The Classification and Diagnosis of the Hypertensive Disorders of Pregnancy: Statement from the International Society for the Study of Hypertension in Pregnancy (ISSHP). *Hypertens. Pregnancy* **2001**, *20* (1), ix-xiv.
5. Osungbade, K. O.; Ige, O. K., Public health perspectives of preeclampsia in developing countries: implication for health system strengthening. *J. Pregnancy* **2011**, *2011*, 481095.
6. Zhou, C. C.; Irani, R. A.; Dai, Y.; Blackwell, S. C.; Hicks, M. J.; Ramin, S. M.; Kellems, R. E.; Xia, Y., Autoantibody-mediated IL-6-dependent endothelin-1 elevation underlies pathogenesis in a mouse model of preeclampsia. *J. Immunol.* **2011**, *186* (10), 6024-34.
7. English, F. A.; Kenny, L. C.; McCarthy, F. P., Risk factors and effective management of preeclampsia. *Integr. Blood Press. Control* **2015**, *8*, 7-12.
8. Duley, L., The global impact of pre-eclampsia and eclampsia. *Semin. Perinatol.* **2009**, *33* (3), 130-137.
9. Cincotta, R. B.; Brennecke, S. P., Family history of pre-eclampsia as a predictor for pre-eclampsia in primigravidas. *Int. J. Gynaecol. Obstet.* **1998**, *60* (1), 23-7.

10. Hutcheon, J. A.; Lisonkova, S.; Joseph, K. S., Epidemiology of pre-eclampsia and the other hypertensive disorders of pregnancy. *Best Pract. Res. Clin. Obstet. Gynaecol.* **2011**, 25 (4), 391-403.
11. Cartwright, J. E.; Fraser, R.; Leslie, K.; Wallace, A. E.; James, J. L., Remodelling at the maternal–fetal interface: relevance to human pregnancy disorders. *Reproduction* **2010**, 140 (6), 803-813.
12. Red-Horse, K.; Zhou, Y.; Genbacev, O.; Prakobphol, A.; Foulk, R.; McMaster, M.; Fisher, S. J., Trophoblast differentiation during embryo implantation and formation of the maternal-fetal interface. *J. Clin. Invest.* **2004**, 114 (6), 744-754.
13. Huppertz, B.; Frank, H. G.; Reister, F.; Kingdom, J.; Korr, H.; Kaufmann, P., Apoptosis cascade progresses during turnover of human trophoblast: analysis of villous cytotrophoblast and syncytial fragments in vitro. *Laboratory investigation; a journal of technical methods and pathology* **1999**, 79 (12), 1687-1702.
14. Ashton, S. V.; Whitley, G. S.; Dash, P. R.; Wareing, M.; Crocker, I. P.; Baker, P. N.; Cartwright, J. E., Uterine spiral artery remodeling involves endothelial apoptosis induced by extravillous trophoblasts through Fas/FasL interactions. *Arterioscler. Thromb. Vasc. Biol.* **2005**, 25 (1), 102-8.
15. Young, B. C.; Levine, R. J.; Karumanchi, S. A., Pathogenesis of preeclampsia. *Annu. Rev. Pathol.* **2010**, 5, 173-92.
16. Uzan, J.; Carbonnel, M.; Piconne, O.; Asmar, R.; Ayoubi, J.-M., Pre-eclampsia: pathophysiology, diagnosis, and management. *Vasc. Health Risk Manage.* **2011**, 7, 467-474.

17. Gilbert, J. S.; Ryan, M. J.; LaMarca, B. B.; Sedeek, M.; Murphy, S. R.; Granger, J. P., Pathophysiology of hypertension during preeclampsia: linking placental ischemia with endothelial dysfunction. *Am. J. Physiol.* **2008**, *294* (2), H541-H550.
18. Rajakumar, A.; Whitelock, K. A.; Weissfeld, L. A.; Daftary, A. R.; Markovic, N.; Conrad, K. P., Selective overexpression of the hypoxia-inducible transcription factor, HIF-2alpha, in placentas from women with preeclampsia. *Biol. Reprod.* **2001**, *64* (2), 499-506.
19. Roberts, J. M.; Escudero, C., The placenta in preeclampsia. *Pregnancy Hypertens.* **2012**, *2* (2), 72-83.
20. Sánchez-Aranguren, L. C.; Prada, C. E.; Riaño-Medina, C. E.; Lopez, M., Endothelial dysfunction and preeclampsia: role of oxidative stress. *Front. Physiol.* **2014**, *5*, 372.
21. Myatt, L., Role of placenta in preeclampsia. *Endocrine* **2002**, *19* (1), 103-11.
22. Hung, T. H.; Skepper, J. N.; Burton, G. J., In vitro ischemia-reperfusion injury in term human placenta as a model for oxidative stress in pathological pregnancies. *Am. J. Pathol.* **2001**, *159* (3), 1031-43.
23. Goel, A.; Rana, S., Angiogenic factors in preeclampsia: potential for diagnosis and treatment. *Curr. Opin. Nephrol. Hypertens.* **2013**, *22* (6), 643-650.
24. Woolcock, J.; Hennessy, A.; Xu, B.; Thornton, C.; Tooher, J.; Makris, A.; Ogle, R., Soluble Flt-1 as a diagnostic marker of pre-eclampsia. *Aust. N. Z. J. Obstet. Gynaecol.* **2008**, *48* (1), 64-70.
25. Wang, A.; Rana, S.; Karumanchi, S. A., Preeclampsia: the role of angiogenic factors in its pathogenesis. *Physiology (Bethesda)* **2009**, *24*, 147-58.

26. Vitoratos, N.; Economou, E.; Iavazzo, C.; Panoulis, K.; Creatsas, G., Maternal Serum Levels of TNF-Alpha and IL-6 Long after Delivery in Preeclamptic and Normotensive Pregnant Women. *Mediators Inflamm.* **2010**, 2010.
27. Saito, S.; Sakai, M., Th1/Th2 balance in preeclampsia. *J. Reprod. Immunol.* **2003**, 59 (2), 161-73.
28. Conrad, K. P.; Benyo, D. F., Placental cytokines and the pathogenesis of preeclampsia. *Am. J. Reprod. Immunol.* **1997**, 37 (3), 240-9.
29. Konermann, L.; Ahadi, E.; Rodriguez, A. D.; Vahidi, S., Unraveling the Mechanism of Electrospray Ionization. *Anal. Chem.* **2013**, 85 (1), 2-9.
30. Banerjee, S.; Mazumdar, S., Electrospray Ionization Mass Spectrometry: A Technique to Access the Information beyond the Molecular Weight of the Analyte. *Int. J. Anal. Chem.* **2012**, 2012, 40.
31. Kebarle, P.; Verkerk, U. H., Electrospray: from ions in solution to ions in the gas phase, what we know now. *Mass Spectrom. Rev.* **2009**, 28 (6), 898-917.
32. Croxatto, A.; Prod'hom, G.; Greub, G., Applications of MALDI-TOF mass spectrometry in clinical diagnostic microbiology. *FEMS Microbiol. Rev.* **2012**, 36 (2), 380-407.
33. Chernushevich, I. V.; Loboda, A. V.; Thomson, B. A., An introduction to quadrupole-time-of-flight mass spectrometry. *J. Mass Spectrom.* **2001**, 36 (8), 849-65.
34. Vestal, M. L.; Juhasz, P.; Martin, S. A., Delayed extraction matrix-assisted laser desorption time-of-flight mass spectrometry. *Rapid Commun. Mass Spectrom.* **1995**, 9 (11), 1044-1050.
35. Cotter, R. J.; Gardner, B. D.; Il'tchenko, S.; English, R. D., Tandem time-of-flight mass spectrometry with a curved field reflectron. *Anal. Chem.* **2004**, 76 (7), 1976-81.

36. Graves, P. R.; Haystead, T. A., Molecular biologist's guide to proteomics. *Microbiol. Mol. Biol. Rev.* **2002**, *66* (1), 39-63; table of contents.
37. Vogel, C.; Marcotte, E. M., Insights into the regulation of protein abundance from proteomic and transcriptomic analyses. *Nature reviews. Genetics* **2012**, *13* (4), 227-232.
38. Rozek, W.; Ciborowski, P. S., Proteomics and Genomics. In *Neuroimmune Pharmacology*, Gendelman, H. E.; Ikezu, T., Eds. Springer US: Boston, MA, **2008**; pp 725-741.
39. Hortin, G. L.; Sviridov, D., The dynamic range problem in the analysis of the plasma proteome. *J. Proteomics* **2010**, *73* (3), 629-636.
40. Gundry, R. L.; White, M. Y.; Murray, C. I.; Kane, L. A.; Fu, Q.; Stanley, B. A.; Van Eyk, J. E., Preparation of Proteins and Peptides for Mass Spectrometry Analysis in a Bottom-Up Proteomics Workflow. *Curr. Protoc. Mol. Biol.* **2009**, *CHAPTER*, Unit10.25-Unit10.25.
41. Kedia, K.; Nichols, C. A.; Thulin, C. D.; Graves, S. W., Novel "omics" approach for study of low-abundance, low-molecular-weight components of a complex biological tissue: regional differences between chorionic and basal plates of the human placenta. *Anal. Bioanal. Chem.* **2015**, *407* (28), 8543-56.
42. Ma, B.; Zhang, K.; Hendrie, C.; Liang, C.; Li, M.; Doherty-Kirby, A.; Lajoie, G., PEAKS: powerful software for peptide de novo sequencing by tandem mass spectrometry. *Rapid Commun. Mass Spectrom.* **2003**, *17* (20), 2337-42.
43. Zhao, Y.-Y.; Wu, S.-P.; Liu, S.; Zhang, Y.; Lin, R.-C., Ultra-performance liquid chromatography–mass spectrometry as a sensitive and powerful technology in lipidomic applications. *Chem. Biol. Interact.* **2014**, *220*, 181-192.



44. Köfeler, H. C.; Fauland, A.; Rechberger, G. N.; Trötz Müller, M., Mass Spectrometry Based Lipidomics: An Overview of Technological Platforms. *Metabolites* **2012**, *2* (1), 19-38.
45. Cajka, T.; Fiehn, O., Comprehensive analysis of lipids in biological systems by liquid chromatography-mass spectrometry. *TrAC Trends Anal. Chem.* **2014**, *61*, 192-206.
46. Alvarez, M. T.; Shah, D. J.; Thulin, C. D.; Graves, S. W., Tissue proteomics of the low-molecular weight proteome using an integrated cLC-ESI-QTOFMS approach. *Proteomics* **2013**, *13* (9), 1400-11.
47. Banks, R. E.; Dunn, M. J.; Forbes, M. A.; Stanley, A.; Pappin, D.; Naven, T.; Gough, M.; Harnden, P.; Selby, P. J., The potential use of laser capture microdissection to selectively obtain distinct populations of cells for proteomic analysis--preliminary findings. *Electrophoresis* **1999**, *20* (4-5), 689-700.
48. Walch, A.; Rauser, S.; Deininger, S.-O.; Höfler, H., MALDI imaging mass spectrometry for direct tissue analysis: a new frontier for molecular histology. *Histochem. Cell Biol.* **2008**, *130* (3), 421-434.
49. Berg, D.; Malinowsky, K.; Reischauer, B.; Wolff, C.; Becker, K. F., Use of formalin-fixed and paraffin-embedded tissues for diagnosis and therapy in routine clinical settings. *Methods Mol. Biol.* **2011**, *785*, 109-22.
50. Centlow, M.; Hansson, S. R.; Welinder, C., Differential proteome analysis of the preeclamptic placenta using optimized protein extraction. *Biomed. Res. Int.* **2009**, *2010*.
51. Robinson, J. M.; Ackerman, W. E. t.; Kniss, D. A.; Takizawa, T.; Vandre, D. D., Proteomics of the human placenta: promises and realities. *Placenta* **2008**, *29* (2), 135-43.

52. Centlow, M.; Hansson, S. R.; Welinder, C., Differential Proteome Analysis of the Preeclamptic Placenta Using Optimized Protein Extraction. *J. Biomed. Biotechnol.* **2010**, *2010*, 9.
53. Mine, K.; Katayama, A.; Matsumura, T.; Nishino, T.; Kuwabara, Y.; Ishikawa, G.; Murata, T.; Sawa, R.; Otsubo, Y.; Shin, S.; Takeshita, T., Proteome analysis of human placentae: pre-eclampsia versus normal pregnancy. *Placenta* **2007**, *28* (7), 676-87.
54. Wang, F.; Shi, Z.; Wang, P.; You, W.; Liang, G., Comparative Proteome Profile of Human Placenta from Normal and Preeclamptic Pregnancies. *PLoS One* **2013**, *8* (10), e78025.
55. Vandre, D. D.; Ackerman, W. E. t.; Tewari, A.; Kniss, D. A.; Robinson, J. M., A placental sub-proteome: the apical plasma membrane of the syncytiotrophoblast. *Placenta* **2012**, *33* (3), 207-13.
56. Epiney, M.; Ribaux, P.; Arboit, P.; Irion, O.; Cohen, M., Comparative analysis of secreted proteins from normal and preeclamptic trophoblastic cells using proteomic approaches. *J. Proteomics* **2012**, *75* (6), 1771-7.
57. Ma, K.; Jin, H.; Hu, R.; Xiong, Y.; Zhou, S.; Ting, P.; Cheng, Y.; Yang, Y.; Yang, P.; Li, X., A proteomic analysis of placental trophoblastic cells in preeclampsia-eclampsia. *Cell Biochem. Biophys.* **2014**, *69* (2), 247-58.
58. Korkes, H. A.; Sass, N.; Moron, A. F.; Câmara, N. O. S.; Bonetti, T.; Cerdeira, A. S.; Da Silva, I. D. C. G.; De Oliveira, L., Lipidomic Assessment of Plasma and Placenta of Women with Early-Onset Preeclampsia. *PLoS One* **2014**, *9* (10), e110747.
59. Baig, S.; Lim, J. Y.; Fernandis, A. Z.; Wenk, M. R.; Kale, A.; Su, L. L.; Biswas, A.; Vasoo, S.; Shui, G.; Choolani, M., Lipidomic analysis of human placental

- syncytiotrophoblast microvesicles in adverse pregnancy outcomes. *Placenta* **2013**, *34* (5), 436-42.
60. Tu, C.; Rudnick, P. A.; Martinez, M. Y.; Cheek, K. L.; Stein, S. E.; Slebos, R. J. C.; Liebler, D. C., Depletion of Abundant Plasma Proteins and Limitations of Plasma Proteomics. *J. Proteome Res.* **2010**, *9* (10), 4982-4991.
61. Millionsi, R.; Tolin, S.; Puricelli, L.; Sbrignadello, S.; Fadini, G. P.; Tessari, P.; Arrigoni, G., High abundance proteins depletion vs low abundance proteins enrichment: comparison of methods to reduce the plasma proteome complexity. *PLoS One* **2011**, *6* (5), e19603.
62. Tirumalai, R. S.; Chan, K. C.; Prieto, D. A.; Issaq, H. J.; Conrads, T. P.; Veenstra, T. D., Characterization of the low molecular weight human serum proteome. *Mol. Cell. Proteomics* **2003**, *2* (10), 1096-103.
63. Merrell, K.; Southwick, K.; Graves, S. W.; Esplin, M. S.; Lewis, N. E.; Thulin, C. D., Analysis of low-abundance, low-molecular-weight serum proteins using mass spectrometry. *J Biomol Tech* **2004**, *15* (4), 238-48.
64. Bäckvall, H.; Lehtiö, J. The Low Molecular Weight Proteome: Methods and Protocols,; Springer: New York, 2013

## **2 Novel 'omics' approach to study low abundance, low molecular weight components in a complex biological tissue: Regional differences between chorionic and basal plates of human placenta**

This chapter in large part was reproduced with permission from a published research article: Kedia, K.; Nichols, C. A.; Thulin, C. D.; Graves, S. W., Novel "omics" approach for study of low-abundance, low-molecular-weight components of a complex biological tissue: regional differences between chorionic and basal plates of the human placenta. *Analytical and bioanalytical chemistry* 2015, 407 (28), 8543-56.

### 2.1 Abstract

Tissue proteomics has relied heavily on two-dimensional gel electrophoresis for protein separation and quantitation, followed by single protein isolation, trypsin digestion and mass spectrometric protein identification. Such methods observe predominantly higher abundance, full length proteins. Tissue peptidomics has been recently developed but still interrogates the more highly abundant species, resulting often in only dozens of peptides being observed and identified. Tissue lipidomics is likewise new and reported studies limited. We have developed an 'omics' approach that surveys over 7,000 endogenous, lower molecular weight, low abundance species and have applied this to a human tissue, placenta. Placenta is thought to play a role in complications of pregnancy and its proteomic evaluation is of substantial interest. Past research on the placental proteome has studied abundant, higher molecular weight proteins. Large scale, global proteomics or peptidomics have had limited application to placenta but either would be challenging owing to the anatomic complexity and broad concentration range of proteins in this

tissue. Our approach, involving protein depletion, capillary liquid chromatography, and tandem mass spectrometry attempted to identify molecular differences between two placental regions of the same tissue having only slightly different cellular composition. Our analysis revealed 16 species with statistically significant differences between the two regions. Tandem mass spectrometry successfully sequenced or otherwise identified twelve of these. The method's successfully finding and identifying regional differences in the expression of low-abundance, lower molecular weight biomolecules demonstrates the potential of our approach.

## 2.2 Introduction

Tissue proteomics has historically relied on single- or two-dimensional gel electrophoresis (2-DGE) for separation and quantitation of tissue proteins. This has typically been followed by single protein isolation, trypsin digestion and mass spectrometric (MS) analysis to provide protein identification by database comparison.<sup>1,2</sup> These approaches survey highly abundant, larger molecular weight proteins. These methods, without tandem MS fragmentation studies employing collisional-induced dissociations or electron-transfer dissociation, do not provide direct amino acid sequences. None of these methods, in the absence of fragmentation, identifies post-translational modifications (PTMs) or chemical changes that can occur in response to reactive oxygen species (ROS) or chemical modifiers directly. Other 'global' proteomic approaches, such as multi-dimensional protein identification technology (MudPIT) rely on successive chromatographic separations, most often after trypsin digestion, rather than electrophoretic methods.<sup>3</sup> They have also been used for the assessment of tissues.<sup>4</sup> These global approaches often involve amino acid sequencing of tryptic digest fragments to identify proteins and associated PTMs. Such global methods survey a greater number of full length proteins than 2-DGE but generally

still suffer from ion suppression and masking of low-abundance components. They are not currently designed to study peptides or lipids. More recently, top-down methods have been developed that allow for the injection of intact, full-length proteins onto the MS system and can include amino acid sequencing and the observation of PTMs.<sup>5,6</sup> However, such approaches often require more than one separation step prior to MS analysis, survey proteins that have higher charge states yielding sufficiently low mass to charge ratios and typically require very highly mass-accurate instruments such as Fourier transform ion cyclotron resonance mass spectrometers. While proteomics studies are valuable, they still focus on higher molecular weight, more highly abundant proteins. The highly expressed cell proteins typically measured are often cytoskeletal elements or are involved in protein folding and trafficking or perform various house-keeping functions and are less frequently involved in regulation and disease processes. Hence, interrogating smaller, lower abundance components in cells may be as important as probing the higher abundance proteins.

Alternatively, tissue peptidomics has been recently developed and employed for cataloguing peptides present in a particular tissue or for quantitative comparisons between tissues using both label free<sup>7</sup> and isotope labeled tags (ICAT, iTRAQ).<sup>8,9</sup> Labelling techniques such as iTRAQ applied to tissue peptides appears to measure dozens of peptides.<sup>9</sup> However, different labeling agents react inconsistently with different peptides suggesting variable quantitation.<sup>9</sup> Such techniques are not useful for lipids. These peptidomics methods hold promise but appear limited in the number and type of small cell constituents assayed. Tissue lipidomics frequently employs tissue homogenization followed by organic solvent extraction and injection of extracted molecules onto to the MS without or with prior chromatographic separation.<sup>10-12</sup> Fragmentation studies have been attempted but there is not a well-developed reference database to allow for lipid

identification from fragment mass comparison. Identification requires careful assessment of mass differences between individual fragment peaks to characterize the neutral loss components and thereby identify molecular parts present in the pre-fragmentation parent species.

We have developed a unique and complementary approach to analyze low abundance, lower molecular weight components in tissue specimens.<sup>13</sup> We employ a protein depletion step.<sup>14</sup> This desorbs low molecular weight species from binding partners and with the removal of highly abundant proteins allows for the interrogation of several thousand additional molecular species. The method has been applied to tissue as part of an initial study evaluating its analytical reliability and its breadth of coverage.<sup>13</sup> It was sufficiently reproducible to allow for label free quantitative comparisons between different organs and was able to observe over 7,000 molecular species.<sup>13</sup> This method considers lower abundance, small proteins, peptides, lipids and potentially other biomolecules and allows for relatively seamless tandem MS fragmentation studies to provide *de novo* amino acid sequencing for polypeptides and chemical characterization and classification of lipids.<sup>15</sup> Such fragmentation data can identify post-translational modifications, oxidative damage and/or other non-physiologic chemical modifications. In this report this novel approach has been applied to human tissue.

Certainly, one of the most challenging but important targets for tissue proteomics is the human placenta. The placenta is of clinical interest because of its almost certain involvement in preeclampsia (PE), a disease complicating 2-10% of all pregnancies that results in as many as 75,000 maternal deaths yearly.<sup>16</sup> The placenta is required for PE and evidence suggests alterations in placental biochemistry occur prior to and likely lead to established PE.<sup>17</sup>

One rather unique challenge in working with the placenta is that it is formed from cells originating from both the fetus and the mother but the cells are interspersed rather than compartmentalized (Figure 2.1).<sup>44</sup> Emerging evidence suggests that specific early changes that may contribute to PE arise sometimes in the fetal and sometimes in the maternal derived tissues.<sup>18</sup> These studies have usually measured single protein targets, but nonetheless underscore the importance of distinguishing between fetal and maternal regions in the placenta if one is to understand PE fully.<sup>19</sup> Fixing and staining tissue may allow a particular cell type to be identified and immunostaining may allow for monitoring of a specific protein's abundance in that cell type but this approach is not amenable to global analysis of molecular mediators or modified dynamics. Furthermore, quantitative comparative proteomic approaches would be difficult, if not impossible, to carry out after such chemical modifications even though there are methods that can reverse much of the cross-linking initiated by fixatives.<sup>20</sup> Placental proteomics has only been attempted relatively recently and has mostly studied highly abundant proteins.<sup>21, 22</sup> There have been a small number of more global proteomics studies attempted on the placenta.<sup>23, 24</sup> These studies have focused on a single class of biomolecules, for example proteins<sup>23</sup> or metabolites.<sup>24</sup> However, there do not appear to have been other 'omics' studies to probe the lower molecular weight components of placenta. Additionally, there has been no effort in prior placental proteomic studies to investigate regional differences within the placenta. Consequently, we considered the use of our novel tissue 'omics' approach for this target as an important demonstration of the method's utility. The intent of this study was to assess the robustness of the method in finding region-specific, quantitative differences in molecular components, but not to develop a set of cell-specific biomarkers. If this approach is successful, it provides a method for the exploration of thousands of previously unstudied, smaller molecular weight, low abundance components in complex tissues.



It also provides more particularly a way of exploring events potentially mediating diseases, including PE, where one would anticipate that many more differences would be seen between placental regions as part of disease and hence, this approach may allow for clarification not only of which molecules are modified but more specifically clarify whether they have a fetal versus a maternal origin.

## 2.3 Materials and methods

### 2.3.1 Tissue collection

Internal Review Boards of Intermountain Health Care and its affiliated hospitals and of Brigham Young University provided approval of these studies. Placentas were considered discarded materials and no informed consent was obtained, and no personal information was provided. Placentas were collected immediately following uncomplicated vaginal or C-section deliveries (n=12). The fetal amnionic membrane was carefully removed and thin tissue pieces were dissected from the extreme outer surface of the chorionic plate. Placentas were then inverted and on the opposing surface (basal plate), thin tissue pieces were sliced from the very outermost surface of the cotyledons. Both tissue types were collected from a location midway between the cord and the peripheral edge of the placenta along the same vertical axis. Care was taken to maintain consistency in this process. After collection, tissues were rapidly frozen on dry ice and maintained frozen until processed further.

### 2.3.2 Tissue homogenization

Frozen placental tissue from one location was finely minced using a sterile stainless steel blade. These shavings (around 500 mg) were then placed in a 5 mL stainless steel ball mill cylinder containing 12–15, 3-mm chromium steel grinding balls. The vessel was flash frozen in liquid nitrogen for 4 min and shaken using a ball mill dismembrator (Mikro-Dismembrator S, Sartorius, Göttingen, Germany) operating at 2000 rpm for 8-10 minutes to form a paste-like homogenate. The tissue homogenate was re-suspended in 5 mL of cold physiological phosphate buffered saline (PBS, pH 7.2). This mixture was vortexed thoroughly and centrifuged (Sorval RT7, Kendro Laboratory Products, Newton, CT) for 10 min at 4000 rpm (8046xg) at 4°C. Aliquots of 200 µL of the supernatant were stored at -80°C for further processing. A broad-spectrum proteolytic enzyme inhibitor cocktail was added to specimen prior to processing (Sigma Aldrich, catalogue number P9599). Additionally, processing at cold temperatures and immediate freezing were employed to further prevent proteolysis.

### 2.3.3 Protein depletion

Highly abundant, high molecular weight proteins were precipitated by adding 2:1 (v/v) acetonitrile to the homogenate. The mixture was vortexed briefly, placed at room temperature for 30 min, and centrifuged (IEC Mcromax RF, Thermo Fisher Scientific, Waltham, MA) at 14,000 rpm (13107xg) for 10 min at 4°C. The pellet was discarded and the supernatant (~550 µL) was transferred to a new Eppendorf tube containing 300 µL of HPLC-grade water. The total volume was then reduced to 200 µL using a vacuum centrifuge (CentriVap Concentrator, Labconco Corporation, Kansas City, MO) at 37°C. The apparent protein concentration of each sample was de-

terminated (Pierce Microplate BCA Protein Assay Kit, Thermo Scientific, Waltham, MA). A volume of the lyophilized sample equivalent to 20  $\mu\text{g}$  of protein was then dried in vacuo to a volume of 10  $\mu\text{L}$ . Then 10  $\mu\text{L}$  of 88% formic acid was added, each sample briefly vortexed, and 5  $\mu\text{L}$  of sample having a concentration of 1  $\mu\text{g}/\mu\text{L}$  apparent protein injected onto the capillary liquid chromatography-mass spectrometer (cLC/MS) system. This single protein-depleted specimen contained small proteins, peptides, lipids and potentially other metabolites.

#### 2.3.4 Chromatographic separation

Reverse-phase capillary liquid chromatography (cLC) separation was then performed using an LC Packings Ultimate Capillary HPLC pump system, with a FAMOS<sup>®</sup> autosampler (Dionex Corporation, Sunnyvale, CA, USA). The system involved a 1 mm (16.2  $\mu\text{l}$ ) dry-packed MicroBore guard column (IDEX Health and Science, Oak Harbor, WA), coupled to a 15 cm x 250  $\mu\text{m}$  i.d. capillary column, slurry-packed in-house with POROS R1 reverse-phase medium (Applied Biosystems, Foster City, CA). The elution gradient was generated using an aqueous phase: 98% HPLC grade water, 2% acetonitrile, 0.1% formic acid and an organic phase: 98% acetonitrile, 2% HPLC grade water, 0.1% formic acid. This packing material had been previously used over a prolonged period for experiments involving both serum and tissue proteomics and allowed continuity in experiments with good chromatographic reproducibility.<sup>14</sup> The gradient began with 3 min of 95% aqueous and 5% organic phase, followed by a linear rise in organic phase to 60% over the next 24 min. The gradient was then increased linearly to 95% organic phase/5% aqueous phase over the next 7 min, held at 95% organic phase for 7 min and returned to 95% aqueous phase over 5 min. The column was allowed to re-equilibrate until the end time of the run (58 min). The flow rate was 5  $\mu\text{L}/\text{min}$ .

### 2.3.5 Mass spectrometric analysis

Eluate was introduced through an electrospray needle into a tandem mass spectrometer (QSTAR Pulsar I quadrupole orthogonal time-of-flight, QTOF, Applied Biosystems, Foster City, CA). The electrospray source was at 4800 V. All samples were run in the positive ion mode. Other MS parameters used during the analyses were: microchannel plate voltage (MCP): 2380 V, plate voltage: 330 V, curtain gas pressure: 20 psi, source gas pressure: 20 psi. A mass spectrum was obtained every 1 sec from  $m/z$  500–2500 over 5–55 minutes elution. Fragmentation studies were carried out with an acquisition rate of 1 spectrum/second. MS calibration was performed by injection of a non-physiological peptide, Glu-1-Fibrinopeptide (GluFib) having an  $m/z$  of 785.85 ( $z=+2$ ). Resolution of the instrument during the time when these samples were run varied between 9,500-10,000. The results were analyzed using Analyst QS® 1.1 software (Applied Biosystems, Foster City, CA, USA). Based on tissue homogenates spiked with this same calibrating peptide, the approach is estimated to have a limit of detection (LOD) of 5-10 nM with the great majority of species interrogated having estimated concentrations of 7-200 nM, representing as little as 2 pg of material per MS peak.

### 2.3.6 Time normalization and data analysis

Elution times can vary from day to day and occasionally from run to run. To compensate, we defined 2 min windows within the useful chromatogram. In each window we selected a central endogenous peak representing a molecule found in all specimens.

These central peaks eluted at approximately 2 min intervals. These were used for time alignment among different runs. To find regional tissue markers, mass spectra from chorionic plate and basal plate were color coded, overlaid, centered on a time marker and peaks visually

inspected to find features appearing to differ in abundance. Every peak appearing to demonstrate quantitative differences between comparison groups was further evaluated. This process involved ‘extracting’ the candidate marker using Analyst software and recording the maximum height of the XIC (extracted ion chromatogram) peak. Time markers selected to correct for variation in elution times (in order of increasing elution times) had mass-to-charge ratios as follow: 695.12 ( $z=+4$ ), 827.77 ( $z=+6$ ), 685.9 ( $z=+4$ ), 672.7 ( $z=+3$ ), 1009.4 ( $z < +10$ ), 616.19 ( $z=+1$ ), 526.3 ( $z=+1$ ), 524.3 ( $z=+1$ ), 650.4 ( $z=+1$ ), 675.56 ( $z=+1$ ). The peptide  $m/z$  1009.4 had a charge estimated as a +14.

The analytical performance of the method has been previously evaluated<sup>13</sup> and demonstrated coefficients of variation from 23.0 to 26.8% for single analytes being measured in different precipitates of the same tissue. This compares favorably to proteomics results using 2-DGE-MS methods.<sup>25,26</sup> Other global or top-down proteomics methods have not frequently reported quantitative reproducibility, but one study reported a CV of 36% for technical replicates.<sup>27</sup>

### 2.3.7 Statistical analysis

A Student’s t-test was performed to determine whether the abundance of an extracted peak was different between the two regions. A p-value of less than 0.05 was considered statistically significant. Additionally, the consistency of these differentially expressed molecules to be increased in the chorionic or basal plates was assessed by constructing 2 x 2 contingency tables and applying a Fisher Exact test to the results (Table 2.1). Finally, as an indication of biologic variability, we have calculated relative standard deviations (%RSD) for each of the 16 differentially expressed species in each region and included these in Table 2.1.

### 2.3.8 Normalization of candidate markers to reduce non-biological variation

For all statistically significant candidate markers a reference peak was selected. This was an endogenous peak that eluted in a time interval closer to the candidate marker and was present in all samples in comparable abundance across comparison groups. To normalize candidate peaks, the intensity of the candidate marker was divided by the intensity of the reference peak. Reference peaks selected to normalize species in elution window 1, 2, 3, 4, 6, 7 and 10 had the following mass to charge ratios: 1241.17 ( $z=+4$ ), 993.12 ( $z=+5$ ), 660.38 ( $z=+1$ ), 660.38 ( $z=+1$ ), 913.48 ( $z=+1$ ), 913.48 ( $z=+1$ ), and 563.57 ( $z=+1$ ). All these reference peaks were quantitatively the same between chorionic and basal plates ( $p > 0.1$ ). This approach has been previously evaluated with an overall coefficient of variation of  $\sim 25\%$  in terms of combined pre-analytical and analytical variability.<sup>13</sup> A Student's t-test was then performed a second time on normalized values.

### 2.3.9 Identification of peptides of interest by tandem MS

Significantly different molecules were submitted to tandem MS with collisionally-induced dissociation (CID). The fragmentation pattern produced was used in an attempt to determine the amino acid sequence and parent protein. One or more samples containing high levels of the peptide of interest were thawed and 5  $\mu\text{g}$  of the sample containing 2.5  $\mu\text{L}$  of 88% formic acid was hand-injected into the cLC-MS system. Fragmentation data were collected for 2 minutes using argon or nitrogen as the collision gas. Different collision energies were used to provide more complete production of b- and y-series fragment ions. Spectra obtained from different collision energies were summed to obtain more complete coverage. Charge states of peaks in the export data list were checked for any misassigned charge states. Charge states for all the peaks were converted to their +1  $m/z$  values by using the formula  $+1 \text{ mass} = m/z \text{ value} * \text{charge} - (\text{charge} -$

1H<sup>+</sup>). This corrected list was then submitted to the search engine Mascot (Mascot 2.3, [www.matrixscience.com](http://www.matrixscience.com)) which correlated the fragmentation data with archived protein sequence data.

#### 2.3.10 *De novo* sequencing

*De novo* sequencing was attempted on peptides when Mascot failed.<sup>28</sup> Individual amino acids were assigned by measuring the mass differences between fragment ions. Presence of immonium ions aided in identifying the presence of particular amino acids. This process proved to be much more complicated because these peptides were not produced by trypsin digestion. A BLAST search using the National Institutes of Health website (<http://blast.ncbi.nlm.nih.gov>) was performed on the sequence of specific amino acids observed from either Mascot assignment or *de novo* sequencing and the calculated probability (an E score) of having identified the parent protein provided in Table 2.2

#### 2.3.11 Identification of lipid markers

The processing step, involving acetonitrile treatment, produced a specimen that contained in addition to polypeptides, polar or positively charged lipids, including neutral lipids that formed adducts with cations in the elution buffer. During the cLC step, these lipids, mainly phosphatidylcholines (PC) and sphingomyelins (SM) eluted typically at mobile phase organic solvent concentrations of 40% or greater. These lipids become positively charged when sprayed in an acidic mobile phase due to the presence of a quaternary nitrogen in the choline group and protonation of the phosphate group and enter the mass spectrometer, most often as the [M+H]<sup>+</sup> species. Lipids were characterized by the same tandem MS-MS approach as used for peptides with the same instrument parameters. The collision gas was usually nitrogen, and 1 or 2 collision energies

were sufficient to fragment the lipid of interest. LIPID MAPS (lipidmaps.org) database was used to investigate the structure based on parent mass and molecular formula of the concerned lipid, while LIPID MS predictor (<http://www.lipidmaps.org/tools/index.html>) was used to calculate the possible fragment ions.

## 2.4 Results

### 2.4.1 Time markers to align chromatographic elution times

As described above, the total ion chromatogram (TIC) was divided into 2 min windows using time alignment markers. These time windows covered most of the useful chromatogram with its attendant TIC. The many mass spectra recorded during the 2 min were averaged. The time markers are listed in the Methods section above.

### 2.4.2 Differentially abundant low abundance, LMW weight biomolecules between chorionic plate and basal plate.

MS data was color coded by region and overlays of MS data for a given time window were visually inspected to find obvious differences in peak abundance between comparison groups (at least 1.5x or greater). As expected, most peaks were common to both sides of the placenta and present in comparable abundance. Importantly, however a number of peaks differed significantly in their intensity between chorionic plate and basal plate tissue, indicating regional selectivity. Figure 2.2 provides an example. The results demonstrated 16 peaks that exhibited statistically different abundances between the two sides. Table 2.1 summarizes the MS characteristics of these 16 peaks.



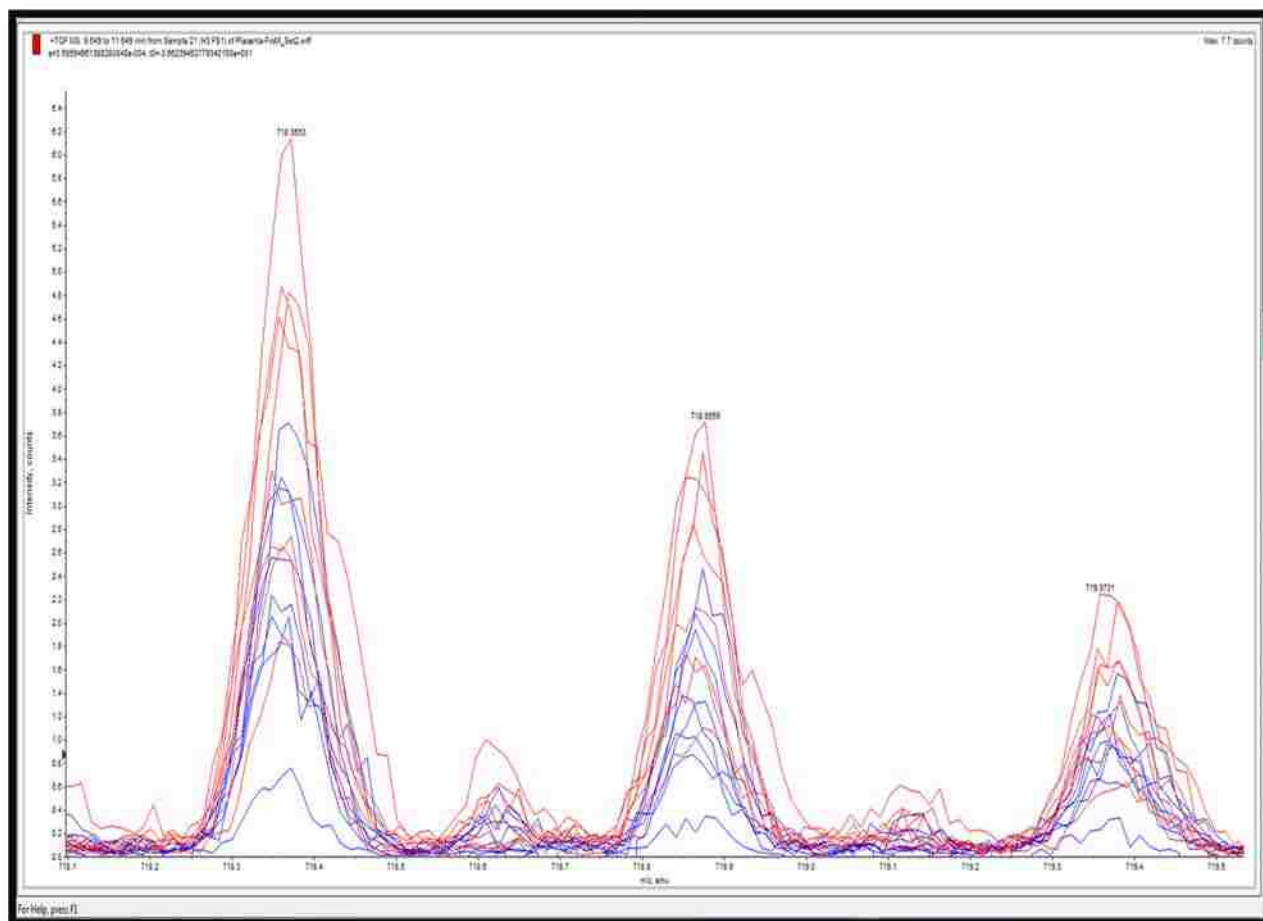

**Figure 2.1. An overlay of 16 mass spectra in the region containing peptide  $m/z$  718.36 with its isotope envelope ( $z = +2$ ). Red: tissue collected from chorionic plate; blue: tissue collected from outer cotyledons (basal plate). This species was more abundant in the chorionic plate of placenta ( $p=0.007$ ).**

Marker(m/z)	z	Student's t-test		Fisher exact	%RSD (Raw)		%RSD (Normalized)	
		Raw p-value	Normalized p-value	p-value	Basal plate	Chorionic plate	Basal plate	Chorionic plate
Window 1 (XIC range: m/z 695-696)								
624.32	+2	0.02	0.02	0.0033	31.7%	32.5%	44.7%	45.8%
718.36	+2	0.005	0.007	0.0001	54.9%	47.6%	68.1%	58.1%
Window 2 (XIC range: m/z 827-828)								
614.38	+3	0.05	0.02	0.0033	41.4%	41.8%	36.7%	29.5%
808.87	+2	0.05	0.05	0.0033	54.8%	49.9%	58.4%	45.7%
Window 3 (XIC range: 685-686)								
760.4	+4	0.06	0.01	0.039	33.0%	38.2%	29.0%	34.0%
Window 4 (XIC window: 672-673)								
857.15	+10	0.01	0.02	0.22	17.3%	18.1%	28.8%	30.0%
Window 6 (XIC range: 616-617)								
520.33	1	0.02	0.03	0.039	42.3%	41.6%	41.9%	41.7%
542.31	1	0.01	0.03	0.039	34.1%	38.9%	38.9%	38.1%
544.33	1	0.01	0.01	0.039	46.2%	45.1%	46.1%	44.9%
566.32	1	0.02	0.03	0.039	39.0%	21.9%	38.9%	21.5%
568.33	1	0.03	0.04	0.039	56.6%	44.7%	54.1%	44.6%
Window 7 (XIC range: 526-527)								
570.34	1	0.03	0.04	0.22	50.4%	36.4%	48.9%	35.8%
1159.50	1	0.02	0.02	0.0001	33.2%	20.4%	31.5%	15.7%
Window 10 (XIC range: 675-676)								
647.55	1	0.07	0.01	0.039	36.5%	39.9%	18.1%	22.5%
673.52	1	0.01	0.001	0.0033	29.8%	37.5%	20.9%	23.4%
701.55	1	0.09	0.01	0.039	19.5%	27.9%	23.6%	24.0%

**Table 2.1. List of 16 differentially molecular species across all 10 time windows.**

### 2.4.3 Identification of peptides

Tandem mass spectrometry (MS/MS) was performed to determine amino acid sequence of significantly different regional peptide markers. Tandem MS/MS was also used to fragment candidate lipid markers, allowing the lipid class to be established.

Of the 7 peptide peaks, two represented the same molecular species observed in two different charge states. Of the 6 unique peptide biomarkers, Mascot provided sequences for two. For example, the peptide  $m/z$  718.36 ( $z = +2$ ) was identified as fetal Hgb ( $\gamma$  subunit).

Two peptides were identified by *de novo* sequencing. The marker with  $m/z$  of 808.82 ( $z=+2$ ) and a neutral mass of 1615.64 Da was identified as fibrinopeptide A phosphorylated at Ser-3. We were able to determine 8 amino acid in series from the MS/MS spectrum. A BLAST search was performed using the NIH protein database to identify the parent protein as fibrinopeptide A. This peptide has a predicted neutral mass of 1535.68 Da, which differed from the parent mass of the marker by  $\sim 80$  Da indicating the presence of a phosphate group. The sequence of this peptide of fibrinopeptide A was entered into a fragment ion calculator to predict individual b and y ions. A value of 80 was added to the serine residue, as the site for phosphorylation (given the absence of threonine and tyrosine, ADSGEGDFLAEGGGVR) which gave good concordance between predicted and observed fragments. This confirmed the identity of this peptide as a phosphorylated fragment fibrinopeptide A (Figure 2.3).

Additionally, a peptide with  $m/z$  of 760.4 and charge state of +4 was identified by *de novo* sequencing. We identified 4 amino acids in series and performed a BLAST search. The parent protein for this peptide was assigned as hemoglobin (Hgb) alpha-2 based on sequence homology and the ability to achieve the observed overall mass of the peptide within the sequence of the parent protein.

Two peptides m/z 857.49 and 624.32 could not be sequenced due to their high charge state and low abundance. The results for all peptide identities are summarized in Table 2.3.

**Table 2.2. Summary of the chemical identities of peptides differentially expressed in chorionic plate and basal plate of human placenta.**

Peptide marker (m/z)	z	Neutral mass	Parent protein	Amino acid sequence <sup>b</sup>	E-score
718.36	+2	1434.72	Hgb <sup>a</sup> subunit gamma (Fetal Hgb)	GHFTEEDKATITS	5E-07
614.38	+3	1840.14	Hgb subunit alpha-1	VLSPADKTNVKAAWGKVG	8E-11
808.82	+2	1615.64	Phosphorylated fibrinopeptide A	ADpS*GEGDFLAEGGGVR	0.013
760.68	+4	3038.72	Hgb subunit alpha-2	VLSPADKTNVKAAWGKVG AHAG-EYGAEALE	3.3

<sup>a</sup>Hgb: Hemoglobin, <sup>b</sup>Sequence represents the amino acid composition of the peptide identified, \*pS in the sequence of 808.82 represents phosphorylation at amino acid serine.

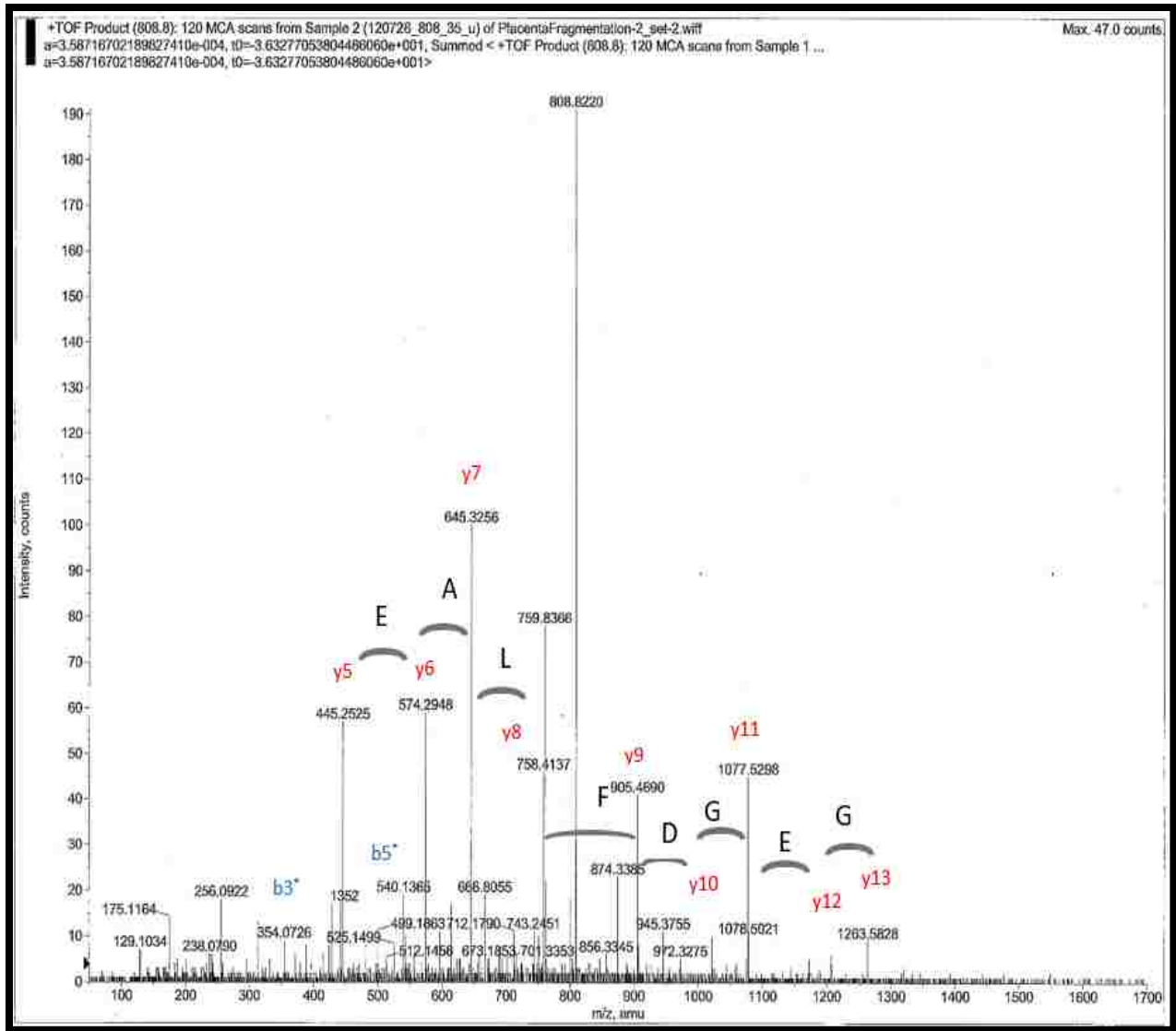

**Figure 2.2. Averaged MS2 spectra of a second differentially expressed peptide m/z 808.82 (z = +2) (mass accuracy of the precursor peak =27 ppm) and the MS fragmentation calculator's prediction of b and y ions. This peptide was identified as a fragment of phosphorylated fibrinopeptide A.**

#### 2.4.4 Identification of lipids

There were 10 quantitatively different, region-specific markers likely to be lipids given their elution later in the cLC chromatogram consistent with their being non-polar and their fragmentation patterns (See Table 2.3). Fragmentation spectra demonstrated an intense peak at  $m/z$  184.07 characteristic of a phosphocholine group found in both phosphatidylcholines (PC) and sphingomyelins (SM). An accurately determined mass for each candidate lipid was entered into the search function of LIPID MAPS database, which presented possible structures and molecular formulas for lipids, hence differentiating PC from SM. This software, however, gives no information regarding likely tandem MS fragment ions. In order to further characterize the markers, LIPID MS predictor was used, which predicts *in silico* possible fragments with their masses. If these  $m/z$  values are then observed in fragmentation spectra, they help establish the marker's identity.

One of the markers with a  $m/z$  of 544.33 ( $z = +1$ ) showed not only an abundant peak at  $m/z$  184.07 characteristic of a phosphocholine but, in addition had several product ions in the fragmentation spectra suggesting it was a sodium (Na) adduct.<sup>29</sup> A prominent peak at  $m/z$  485.23, which represented a loss of trimethylamine (TMA, loss of 59.07 mass units) confirmed it being a Na adduct. This interaction of Na with the lipid makes the negatively charged oxygen available for nucleophilic reactions, and one common result is the loss of TMA. In addition, there was a peak at  $m/z$  339.26, generated by loss of sodium-associated phosphocholine (neutral loss of 205 mass units) from the parent. Further, due to the loss of an acyl-sn-glycerol group from the fragment ions generated through neutral loss of 59.07, there was a prominent peak at  $m/z$  146.97. The peak at 104.10 also evidences the PC to be an LPC.<sup>30</sup> These findings confirm the identity of the lipid marker as an LPC with elemental composition of  $[C_{26}H_{52}NO_7P]Na^+$ . This

is same molecular formula as the LPC with neutral mass of 521.33 (Figure 2.4). Due to the inability of mass spectrometry to determine the location of fatty acids and double bonds within fatty acids, it cannot be confirmed unambiguously that these two molecules represent the same species, but it is nonetheless likely. Similarly, an unidentified marker with  $m/z$  566.32 was identified as a sodiated LPC with elemental composition as  $[C_{28}H_{50}NO_7P]Na^+$ .

The second differentially expressed lipid not identified by reference to LIPID MAPS had an  $m/z$  of 570.34. Fragmentation of this molecule showed an intense peak at 184.07, indicative of a PC or SM. Exact mass studies determined its elemental composition as  $C_{30}H_{52}NO_7P$ . Thus, this lipid molecule is an LPC with a fatty acid 22:5 (docosapentaenoic acid). The general classification and constituents of the other lipids are summarized in Table 2.3.

The other differentially expressed lipids ( $m/z$ 's: 1159.57, 647.52) did not provide an interpretable  $MS^2$  fragment spectra owing to their low initial abundance.



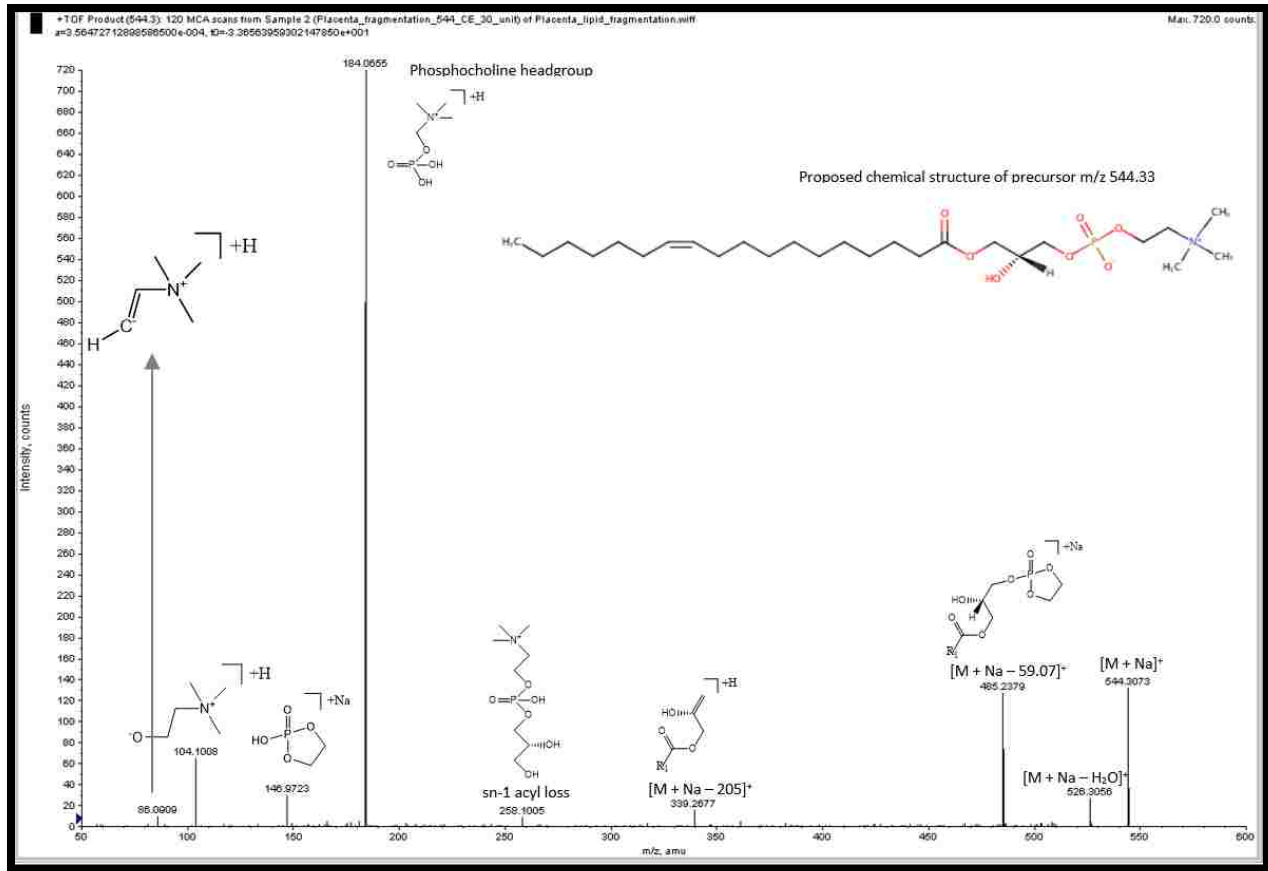

**Figure 2.3.** Summed MS2 spectrum of a differentially expressed sodiated lysophosphatidylcholine ( $m/z$  544.33,  $z = +1$ ) (mass accuracy of the precursor peak = 51), with its collision product ions and their proposed chemical structures or the proposed component lost with fragmentation. Mass accuracies of individual product ions having  $m/z$  values of 86.09, 104.1, 146.97, 184.06, 258.1, 339.26, 485.23 were 64 ppm, 59 ppm, 68 ppm, 42 ppm, 37 ppm, 63 ppm, 53 ppm respectively.

**Table 2.3. Summary of the chemical classes and components of the lipids differentially expressed in chorionic plate versus basal plate of human placenta.**

Lipid marker (m/z)	z	Neutral mass	Lipid class	Molecular formula	Fatty acid components
520.33	+1	519.37	Glycerophospholipids(LPC) <sup>a</sup>	C <sub>26</sub> H <sub>50</sub> NO <sub>7</sub> P	(18:2/0:0) <sup>b</sup>
542.32	+1	541.31	Glycerophospholipids(LPC)	C <sub>28</sub> H <sub>48</sub> NO <sub>7</sub> P	(20:5/0:0)
544.33	[M+Na] <sup>+</sup>	521.33	Glycerophospholipids(LPC)	C <sub>26</sub> H <sub>52</sub> NO <sub>7</sub> P	(18:1/0:0)
566.32	[M+Na] <sup>+</sup>	543.37	Glycerophospholipids(LPC)	C <sub>28</sub> H <sub>50</sub> NO <sub>7</sub> P	(20:4/0:0) or (0:0/20:4)
568.33	+1	567.33	Glycerophospholipids(LPC)	C <sub>30</sub> H <sub>50</sub> NO <sub>7</sub> P	(22:6/0:0)
570.34	+1	569.33	Glycerophospholipids(LPC)	C <sub>30</sub> H <sub>52</sub> NO <sub>7</sub> P	(22:5/0:0) or (0:0/22:5)
673.52	+1	671.52	Phosphosphingolipids	C <sub>37</sub> H <sub>73</sub> N <sub>2</sub> O <sub>6</sub> P	(18:2/14:0)
701.55	+1	700.58	Phosphosphingolipids	C <sub>39</sub> H <sub>77</sub> N <sub>2</sub> O <sub>6</sub> P	(18:1/16:1) or (16:1/18:1) or (18:2/16:0)

<sup>a</sup>LPC: Lysophosphocholine, <sup>b</sup>The annotation (e.g. (18:2/0:0)) describes the number of carbon atoms in the fatty acid chain with the number of double bonds. In this case, the fatty acid is composed of 18 carbons with two double bonds at the sn-1 position of the glycerol backbone, while 0:0 represents the absence of a fatty acid chain at the sn-2 position.

## 2.5 Discussion

Tissue proteomics is an increasingly accepted tool for exploring biochemical changes accompanying normal physiology and pathophysiology. Global, unbiased proteomic approaches using multidimensional separations followed by MS are able to identify hundreds to a few thousand proteins but are not quantitative without a single, predetermined target and having a heavy isotope analogue of the target available which is introduced into the specimen in a defined amount. Such approaches do not document low abundance proteins or other low abundance species. Historically, electrophoretic gel methods, providing some quantitative assessment, have been coupled to MS for protein identification. More recent comparative and quantitative proteomic approaches include ICAT or iTRAQ where heavy or light isotope labeling of two different tissue homogenates or cell lysates allow comparisons between those two states or groups.<sup>31, 32</sup> Recent advances in top-down proteomics involving multiple separations coupled to high resolution MS have allowed intact protein sequencing with identification of hundreds of proteins or proteoforms, including PTMs.<sup>5, 6, 33</sup> However, these methods, including top-down methods, still interrogate only the more abundant, full length proteins. Proteins have obvious importance in cell or tissue physiology, but small proteins, peptides and lipids are also recognized as mediating or regulating many intracellular events.<sup>34</sup>

Peptidomics, including tissue peptidomics, use similar approaches. Both isotopic tagging (ICAT or iTRAQ) and non-isotopic quantitation techniques have been used.<sup>8, 9, 35</sup> Typically, peptides, after their separation from larger proteins, are submitted to liquid chromatography coupled to tandem MS without trypsin digestion, given they are peptides already. Currently, automated sequencing, using data-dependent acquisition to select peptides for fragmentation is used in con-

junction with a tandem mass spectrometer. This results in the top 3 to 20 (depending on instrument) most abundant peptide species in any initial mass spectrum being submitted to fragmentation and the fragment profile submitted to search engines to determine amino acid sequence. Such approaches report dozens of automatically identified sequences,<sup>36</sup> but only for those peptides that are high in abundance (the top 3 to top 20 peaks) in the initial MS and only those that have high enough abundance to provide substantially complete b- and y-fragment ion series in a single pass and only those in low charge states. *De novo* sequencing is dramatically more complicated and involves several runs at different fragmentation energies with compilation of data from those several runs. Typically, these fragments cannot be simply compared to a database. Yet, this approach is required if you are working with low abundance species. Hence, low abundance species, as monitored in our method, cannot currently be sequenced using automated approaches and in depth, *de novo* analysis has been reserved for only those that were quantitatively different in these studies. However, the approach can be applied to any species of any abundance if of interest.

Tissue lipidomic approaches are also relatively new and have been reported primarily for brain tissues.<sup>10-12</sup> These typically use organic solvent extraction methods and direct injection although liquid chromatography coupled to MS has also been used. Such methods have targeted those lipids partitioned into the non-polar organic extract and as such they likely sample a somewhat different set of lipids than those interrogated here. Hence, the methods would be complementary.

With the approach described here a protein depletion step was employed removing highly abundant species and markedly reducing ion suppression. We interrogated 7000-8000 unique, novel, low abundance small proteins, peptides and lipids—thousands more than any other current

method. Moreover, the great majority of these molecules would not be surveyed by other proteomic, peptidomic or lipidomic approaches due to differences in methodology. Hence, this approach adds substantially to the array of tissue molecules that can now be studied by MS. The reproducibility was sufficient<sup>13</sup> to allow for label-free quantitative comparisons. Post translational modifications and modifications due to reactive oxygen species or alkylating agents can be observed. Identification or characterization can be applied to any species observed but automated sequencing procedures would not be adequate for most of the molecules seen in our studies due to instrument limitations and the low concentrations of species. Having to do intense, multi-stepped *de novo* sequencing is not a plus for this approach but one would have to do this regardless of method for any of the low abundance, smaller species in a cell or tissue with current MS instrumentation.

The test of our approach was on placenta. The placenta is interesting clinically but challenging anatomically. Earlier proteomic studies on human placenta have investigated abundant proteins, identifying many structural and housekeeping proteins, including actin, other cytoskeletal proteins, molecular chaperones, and proteins involved in transport.<sup>37</sup> Broadly or narrowly, regional differences within the placenta itself do not appear to have been previously explored using global proteomic methods but may be very important. Other studies have looked selectively at trophoblast cells released from placenta.<sup>38</sup> The human placenta likely participates in disorders of pregnancy, including PE,<sup>16</sup> but how is incompletely understood.<sup>39</sup> There is early evidence that maternal versus fetal cells may participate in different ways in PE.<sup>18</sup> A more in-depth knowledge of the peptide and lipid repertoire by region in placenta would likely yield additional details of the pathologic pathways involved, especially if the number of molecules queried were greater. Our 'omics' approach interrogates many thousand additional small proteins, peptides and lipids

in a tissue that may participate mechanistically or report changes in tissue function and are meant to be complementary. Changes in the placental expression by region is likely to be more dramatic in PE than in unstimulated or non-pathologic placentae as studied here. Having the ability to regionally locate these molecular changes may contribute substantially to our understanding of the placenta's role in PE.

We undertook to study two regions of placenta: the chorionic plate, composed primarily of fetal cells, and the basal plate, consisting of a mixture of fetal (trophoblast) and maternal cells.<sup>44</sup> It was recognized that most biomolecules were found in all cells and with overlap of cell type in these two regions not many differences would be found. Despite this overlap, 16 molecular species demonstrated statistically significant differences between these two placental regions. This suggests that the method was robust and reproducible enough to overcome this challenge. Of these 16, 6 were found to be more abundant in chorionic plate; the remaining 10 were found to be in higher abundance in the basal plate. These were consistent changes occurring in most of the 12 placenta characterized independent of each other (Figure 2.5). Fragmentation, characterization studies were successful in sequencing or chemically classifying 12 markers. Of these, 4 were peptides while the others were lipids.

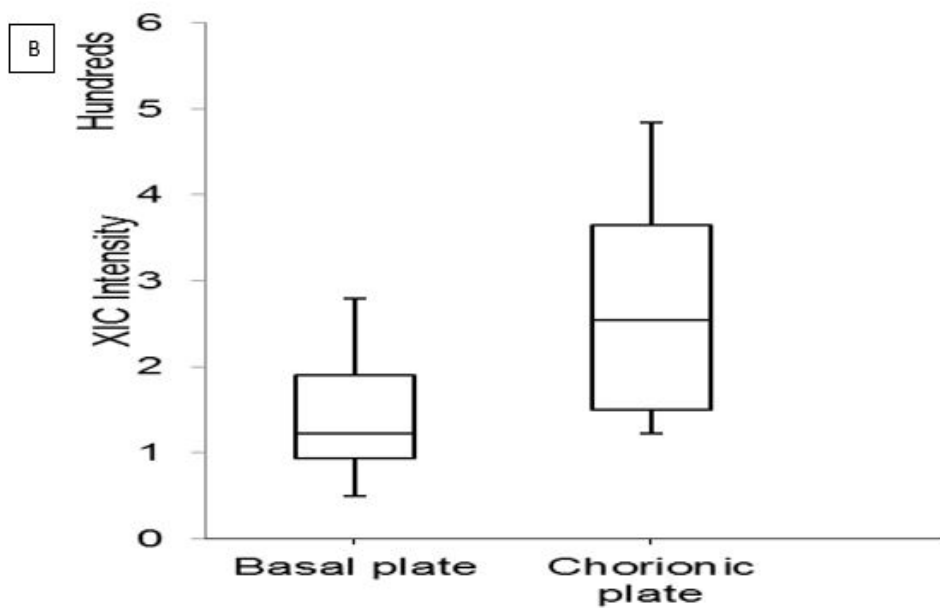
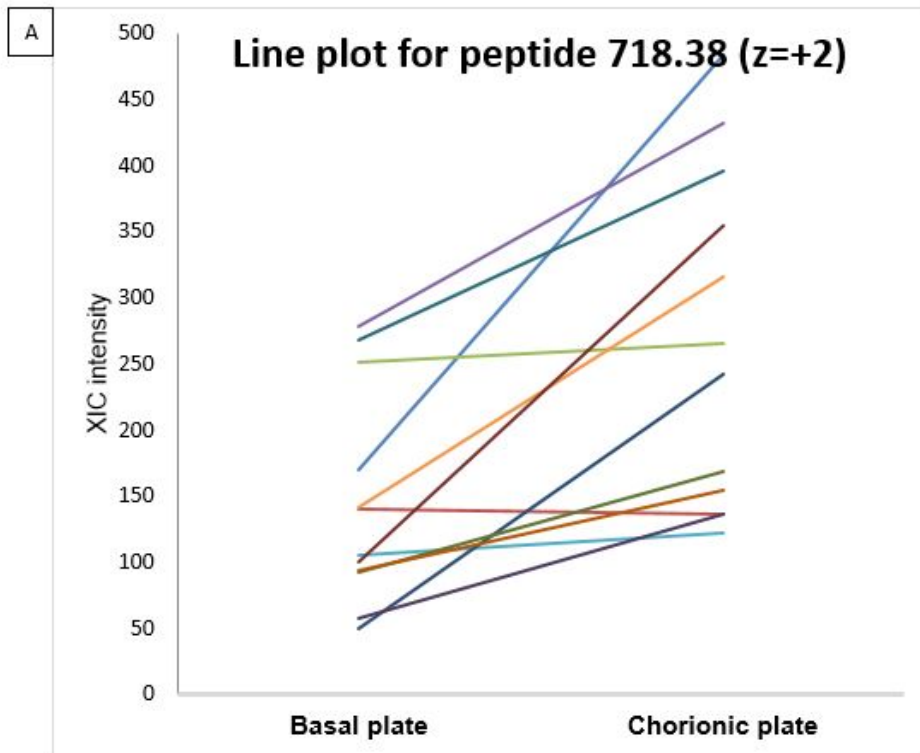

**Figure 2.4. Differential expression of peptide with m/z of 718.36 ( $z = +2$ ).** A. This is a line plot of the abundance of the peptide in the basal versus the chorionic plate of each of the 12 replicates demonstrating the consistency of its differential expression. Each colored line represents a single specimen. B. This is a box and whisker plot of the same peptide and its mean abundance in the same two regions of the 12 placentas.

One of the peptides was derived from fetal hemoglobin (Hgb  $\gamma$ )<sup>40</sup> and more abundant in the chorionic plate of placenta which is predominantly of fetal origin. Another peptide, with m/z of 614.38 and a charge state of +3 was identified as a peptide derived from Hgb alpha-1 and was also more abundant in the chorionic plate, likely in conjunction with the higher Hgb  $\gamma$  present.

Another peptide (m/z = 808.87, z= +2) was a fragment of fibrinopeptide A, phosphorylated at serine 3 and more abundant in the chorionic plate. This agrees with previous research.<sup>41</sup> Fibrinopeptide A (FbA) was found to be in higher abundance in placenta at term. It has also been shown that fetal fibrinogen contains twice as much phosphate as adult fibrinogen.<sup>41</sup> The biological significance of phosphorylation of fetal fibrinogen and of this particular peptide is not known, but phosphorylation of FbA at Ser-3 has been proposed to produce a more efficient enzyme-substrate complex for the highly regulated blood coagulation system as required during pregnancy.<sup>42</sup> The fourth peptide (m/z= 760.4, z= +4) was a fragment of Hgb alpha-2. This peptide was also more abundant in the chorionic plate. The two other peptides could not be sequenced due to low concentration and/or higher charge state. These peptide differences then make physiologic sense.

In addition, regional placental differences in lipids were observed. Most of these lipids were glycerophosphocholines, PCs, although two were sphingomyelins, SMs and all were more abundant in the basal plate. A possible explanation for this might be that implantation of the blastocyst in the uterine wall is accompanied by the endometrial lining being transformed into decidua becoming maternal cells in the placenta more evident in the basal plate.<sup>43</sup> This region has high lipid content<sup>43</sup> and may explain higher concentrations of these in the basal plate.

One limitation of all MS lipidomics is the inability to specify the location of fatty acids as well as the location of double bonds within unsaturated fatty acid constituents. Due to the very



low abundance of our lipid regional markers, it was not possible to use other techniques like NMR to identify the location of double bonds in the fatty acid chains. Characterization of lipids and their fatty acids are aided only modestly by the very limited available lipid databases and lipidomic-focused software.

In this study we have evaluated a novel ‘omics’ approach to explore lower molecular weight species present in a complex tissue, placenta, and have identified subtle regional differences between the chorionic plate, consisting primarily of trophoblast/fetal cells, and the outer surface of cotyledons or basal plate, consisting of a mixture of fetal and decidual cells. This same approach then could be used to probe regional changes that may be part of either normal or disease processes. It is likely possible to determine whether changes arise and progress within a fixed location or whether they occur broadly across a tissue. Using animal models, this approach would appear able to document the location and the progression pathway of specific changes in tissues.

## 2.6 Conclusion

Collectively, these results demonstrate the feasibility of our low molecular ‘omics’ method to probe thousands of less abundant, lower molecular weight species in tissue and identify regional differences within the same tissue allowing for study of temporal and spatial changes as part of both normal and pathologic processes. The method also allowed for relative quantitative comparisons across many tissues and provided identification of differentially expressed molecules as part of a single approach. This method should substantially add to other proteomics or peptidomics methods and allow for a more comprehensive analysis of tissue.

## 2.7 References

1. Chen, J.; Kahne, T.; Rocken, C.; Gatze, T.; Yu, J.; Sung, J. J. Y.; Chen, M.; Hu, P.; Malfetheriner, P.; Ebert, M. P. A., Proteome Analysis of Gastric Cancer Metastasis by Two-Dimensional Gel Electrophoresis and Matrix Assisted Laser Desorption/Ionization-Mass Spectrometry for Identification of Metastasis-Related Proteins. *J. Proteome Res.* **2004**, *3* (5), 1009-1016.
2. Kim, J.; Kim, S. H.; Lee, S. U.; Ha, G. H.; Kang, D. G.; Ha, N. Y.; Ahn, J. S.; Cho, H. Y.; Kang, S. J.; Lee, Y. J.; Hong, S. C.; Ha, W. S.; Bae, J. M.; Lee, C. W.; Kim, J. W., Proteome analysis of human liver tumor tissue by two-dimensional gel electrophoresis and matrix assisted laser desorption/ionization-mass spectrometry for identification of disease-related proteins. *Electrophoresis* **2002**, *23* (24), 4142-56.
3. Washburn, M. P.; Wolters, D.; Yates, J. R., Large-scale analysis of the yeast proteome by multidimensional protein identification technology. *Nat. Biotech.* **2001**, *19* (3), 242-247.
4. Kline, K. G.; Wu, C. C., MudPIT analysis: application to human heart tissue. *Methods Mol. Biol.* **2009**, *528*, 281-93.
5. Catherman, A. D.; Skinner, O. S.; Kelleher, N. L., Top Down proteomics: facts and perspectives. *Biochem. Biophys. Res. Commun.* **2014**, *445* (4), 683-93.
6. Catherman, A. D.; Durbin, K. R.; Ahlf, D. R.; Early, B. P.; Fellers, R. T.; Tran, J. C.; Thomas, P. M.; Kelleher, N. L., Large-scale top-down proteomics of the human proteome: membrane proteins, mitochondria, and senescence. *Mol. Cell. Proteomics: MCP* **2013**, *12* (12), 3465-73.
7. Heroux, M. S.; Chesnik, M. A.; Halligan, B. D.; Al-Gizawiy, M.; Connelly, J. M.; Mueller, W. M.; Rand, S. D.; Cochran, E. J.; LaViolette, P. S.; Malkin, M. G.; Schmainda, K. M.;

- Mirza, S. P., Comprehensive characterization of glioblastoma tumor tissues for biomarker identification using mass spectrometry-based label-free quantitative proteomics. *Physiol. Genomics* **2014**, *46* (13), 467-81.
8. Wardman, J.; Fricker, L. D., Quantitative peptidomics of mice lacking peptide-processing enzymes. *Methods Mol. Biol.* **2011**, *768*, 307-23.
  9. Che, F. Y.; Fricker, L. D., Quantitative peptidomics of mouse pituitary: comparison of different stable isotopic tags. *J. Mass Spectrom* **2005**, *40* (2), 238-49.
  10. Tajima, Y.; Ishikawa, M.; Maekawa, K.; Murayama, M.; Senoo, Y.; Nishimaki-Mogami, T.; Nakanishi, H.; Ikeda, K.; Arita, M.; Taguchi, R.; Okuno, A.; Mikawa, R.; Niida, S.; Takikawa, O.; Saito, Y., Lipidomic analysis of brain tissues and plasma in a mouse model expressing mutated human amyloid precursor protein/tau for Alzheimer's disease. *Lipids Health Dis.* **2013**, *12*, 68.
  11. Chan, R. B.; Oliveira, T. G.; Cortes, E. P.; Honig, L. S.; Duff, K. E.; Small, S. A.; Wenk, M. R.; Shui, G.; Di Paolo, G., Comparative lipidomic analysis of mouse and human brain with Alzheimer disease. *J. Biol. Chem.* **2012**, *287* (4), 2678-88.
  12. Korkes, H. A.; Sass, N.; Moron, A. F.; Câmara, N. O. S.; Bonetti, T.; Cerdeira, A. S.; Da Silva, I. D. C. G.; De Oliveira, L., Lipidomic Assessment of Plasma and Placenta of Women with Early-Onset Preeclampsia. *PLoS One* **2014**, *9* (10), e110747.
  13. Alvarez, M. T.; Shah, D. J.; Thulin, C. D.; Graves, S. W., Tissue proteomics of the low-molecular weight proteome using an integrated cLC-ESI-QTOFMS approach. *Proteomics* **2013**, *13* (9), 1400-11.
  14. Esplin, M. S.; Merrell, K.; Goldenberg, R.; Lai, Y.; Iams, J. D.; Mercer, B.; Spong, C. Y.; Miodovnik, M.; Simhan, H. N.; van Dorsten, P.; Dombrowski, M., Proteomic

- identification of serum peptides predicting subsequent spontaneous preterm birth. *Am. J. Obstet. Gynecol.* **2010**, *204* (5), 391.e1-391.e8.
15. Merrell, K.; Thulin, C. D.; Esplin, M. S.; Graves, S. W., An integrated serum proteomic approach capable of monitoring the low molecular weight proteome with sequencing of intermediate to large peptides. *Rapid Commun. Mass Spectrom.* **2009**, *23* (17), 2685-96.
  16. Roberts, D. J.; Post, M. D., The placenta in pre-eclampsia and intrauterine growth restriction. *J. Clin. Pathol.* **2008**, *61* (12), 1254-1260.
  17. Prouillac, C.; Lecoecur, S., The Role of the Placenta in Fetal Exposure to Xenobiotics: Importance of Membrane Transporters and Human Models for Transfer Studies. *Drug Metab. Dispos.* **2010**, *38* (10), 1623-1635.
  18. Hwang, H. S.; Park, S. H.; Park, Y. W.; Kwon, H. S.; Sohn, I. S., Expression of cellular prion protein in the placentas of women with normal and preeclamptic pregnancies. *Acta Obstet. Gynecol. Scand.* **2010**, *89* (9), 1155-61.
  19. Damsky, C. H.; Fitzgerald, M. L.; Fisher, S. J., Distribution patterns of extracellular matrix components and adhesion receptors are intricately modulated during first trimester cytotrophoblast differentiation along the invasive pathway, in vivo. *J. Clin. Invest.* **1992**, *89* (1), 210-22.
  20. Reimel, B. A.; Pan, S.; May, D. H.; Shaffer, S. A.; Goodlett, D. R.; McIntosh, M. W.; Yerian, L. M.; Bronner, M. P.; Chen, R.; Brentnall, T. A., Proteomics on Fixed Tissue Specimens - A Review. *Curr. Proteomics* **2009**, *6* (1), 63-69.
  21. Robinson, J. M.; Vandre, D. D.; Ackerman, W. E. t., Placental proteomics: a shortcut to biological insight. *Placenta* **2009**, *30* (9), 13.

22. Centlow, M.; Hansson, S. R.; Welinder, C., Differential Proteome Analysis of the Preeclamptic Placenta Using Optimized Protein Extraction. *J. Biomed. Biotechnol.* **2010**, *2010*.
23. Wang, F.; Shi, Z.; Wang, P.; You, W.; Liang, G., Comparative proteome profile of human placenta from normal and preeclamptic pregnancies. *PLoS One* **2013**, *8* (10), 2013.
24. Dunn, W. B.; Brown, M.; Worton, S. A.; Crocker, I. P.; Broadhurst, D.; Horgan, R.; Kenny, L. C.; Baker, P. N.; Kell, D. B.; Heazell, A. E., Changes in the metabolic footprint of placental explant-conditioned culture medium identifies metabolic disturbances related to hypoxia and pre-eclampsia. *Placenta* **2009**, *30* (11), 974-80.
25. Andersen, H. U.; Fey, S. J.; Larsen, P. M.; Nawrocki, A.; Hejnaes, K. R.; Mandrup-Poulsen, T.; Nerup, J., Interleukin-1beta induced changes in the protein expression of rat islets: a computerized database. *Electrophoresis* **1997**, *18* (11), 2091-103.
26. Schröder, S.; Zhang, H.; Yeung, E. S.; Jansch, L.; Zabel, C.; Wätzig, H., Quantitative Gel Electrophoresis: Sources of Variation. *J. Proteome Res.* **2008**, *7* (3), 1226-1234.
27. Piehowski, P. D.; Petyuk, V. A.; Orton, D. J.; Xie, F.; Ramirez-Restrepo, M.; Engel, A.; Lieberman, A. P.; Albin, R. L.; Camp, D. G.; Smith, R. D.; Myers, A. J., Sources of Technical Variability in Quantitative LC-MS Proteomics: Human Brain Tissue Sample Analysis. *J. Proteome Res.* **2013**, *12* (5), 2128-2137.
28. Ma, B.; Zhang, K.; Hendrie, C.; Liang, C.; Li, M.; Doherty-Kirby, A.; Lajoie, G., PEAKS: powerful software for peptide de novo sequencing by tandem mass spectrometry. *Rapid Commun. Mass Spectrom.* **2003**, *17* (20), 2337-42.
29. Xu, F.; Zou, L.; Lin, Q.; Ong, C. N., Use of liquid chromatography/tandem mass spectrometry and online databases for identification of phosphocholines and

- lysophosphatidylcholines in human red blood cells. *Rapid Commun. Mass Spectrom.* **2009**, *23* (19), 3243-54.
30. Al-Saad, K. A.; Siems, W. F.; Hill, H. H.; Zabrouskov, V.; Knowles, N. R., Structural analysis of phosphatidylcholines by post-source decay matrix-assisted laser desorption/ionization time-of-flight mass spectrometry. *J. Am. Soc. Mass Spectrom.* **2003**, *14* (4), 373-82.
31. Shi, Z.; Long, W.; Zhao, C.; Guo, X.; Shen, R.; Ding, H., Comparative proteomics analysis suggests that placental mitochondria are involved in the development of pre-eclampsia. *PLoS One* **2013**, *8* (5), 2013.
32. DeSouza, L.; Diehl, G.; Rodrigues, M. J.; Guo, J.; Romaschin, A. D.; Colgan, T. J.; Siu, K. W., Search for cancer markers from endometrial tissues using differentially labeled tags iTRAQ and cICAT with multidimensional liquid chromatography and tandem mass spectrometry. *J. Proteome Res.* **2005**, *4* (2), 377-86.
33. Kelleher, N. L., Top-down proteomics. *Anal. Chem.* **2004**, *76* (11), 197A-203A.
34. Gygi, S. P.; Rist, B.; Griffin, T. J.; Eng, J.; Aebersold, R., Proteome analysis of low-abundance proteins using multidimensional chromatography and isotope-coded affinity tags. *J. Proteome Res.* **2002**, *1* (1), 47-54.
35. Xu, Z.; Wu, C.; Xie, F.; Slys, G. W.; Tolic, N.; Monroe, M. E.; Petyuk, V. A.; Payne, S. H.; Fujimoto, G. M.; Moore, R. J.; Fillmore, T. L.; Schepmoes, A. A.; Levine, D. A.; Townsend, R. R.; Davies, S. R.; Li, S.; Ellis, M.; Boja, E.; Rivers, R.; Rodriguez, H.; Rodland, K. D.; Liu, T.; Smith, R. D., Comprehensive Quantitative Analysis of Ovarian and Breast Cancer Tumor Peptidomes. *J. Proteome Res.* **2009**, *14* (1), 422-433.

36. Michalski, A.; Cox, J.; Mann, M., More than 100,000 Detectable Peptide Species Elute in Single Shotgun Proteomics Runs but the Majority is Inaccessible to Data-Dependent LC/MS/MS. *J. Proteome Res.* **10** (4), 1785-1793.
37. Paule, S.; Li, Y.; Nie, G., Cytoskeletal remodelling proteins identified in fetal-maternal interface in pregnant women and rhesus monkeys. *J. Mol. Histol.* **2011**, *42* (2), 161-6.
38. Orendi, K.; Kivity, V.; Sammar, M.; Grimpel, Y.; Gonen, R.; Meiri, H.; Lubzens, E.; Huppertz, B., Placental and trophoblastic in vitro models to study preventive and therapeutic agents for preeclampsia. *Placenta* **2011**, *2011* (32), 023.
39. Mutter, W. P.; Karumanchi, S. A., Molecular mechanisms of preeclampsia. *Microvasc. Res.* **2008**, *75* (1), 1-8.
40. Bauer, D. E.; Orkin, S. H., Update on fetal hemoglobin gene regulation in hemoglobinopathies. *Curr. Opin. Pediatr.* **2011**, *23* (1), 1-8.
41. Seydewitz, H. H.; Witt, I., The fraction of high molecular weight (HMW) fibrinogen and phosphorylated fibrinopeptide A in fetal fibrinogen. *Thromb. Res.* **1989**, *55* (6), 785-90.
42. Maurer, M. C.; Peng, J. L.; An, S. S.; Trosset, J. Y.; Henschen-Edman, A.; Scheraga, H. A., Structural examination of the influence of phosphorylation on the binding of fibrinopeptide A to bovine thrombin. *Biochemistry* **1998**, *37* (17), 5888-902.
43. Lu, G.; Zhu, S.; Ke, Y.; Jiang, X.; Zhang, S., Transplantation-potential-related biological properties of decidua basalis mesenchymal stem cells from maternal human term placenta. *Cell Tissue Res.* **2013**, *352* (2), 301-12.
44. Wang, Y.; Zhao, S. *Vascular Biology of the Placenta*. San Rafael (CA): Morgan & Claypool Life Sciences, 2010

### 3 Global ‘Omics’ Evaluation of Human Placental Responses to Preeclamptic Conditions

This chapter is in large part was reproduced with permission from an accepted research article: Kedia, K.; Smith, S.; Wright, A.H.; Barnes, J.; Tolley, D.H.; Esplin, S.; Graves, S.W., Global ‘Omics’ Evaluation of Human Placental Responses to Preeclamptic Conditions. *American Journal of Obstetrics & Gynecology*

#### 3.1 Abstract

Preeclampsia is a leading cause of maternal death. Its cause is still debated but there is general agreement that the placenta plays a central role. Perhaps the most commonly proposed contributors to preeclampsia include placental hypoxia, oxidative stress and an increased pro-inflammatory cytokines. How the placenta responds to these abnormalities has been considered but not as part of a comprehensive analysis of low molecular weight biomolecules and their responses to these accepted preeclamptic conditions. Using a peptidomic approach, we sought to identify a set of molecules exhibiting differential expression in consequence of provocative agents/chemical mediators of preeclampsia applied to healthy human placental tissue. Known PE conditions were imposed on normal placental tissue from 13 uncomplicated pregnancies and changes in the low molecular weight biomolecules evaluated. A t-test was used to identify potential markers for each imposed stress. These markers were then submitted to a LASSO multinomial logistic regression model to identify signatures specific to each stressor. Estimates of model performance on external data were obtained through internal validation. A total of 146 markers were increased/decreased as a consequence of exposure to proposed mediators of preeclampsia.



Of these 75 changed with hypoxia; 23 with hypoxia-reoxygenation/oxidative stress and 48 from exposure to TNF $\alpha$ . These markers were chemically characterized using tandem mass spectrometry. Identification rates were: hypoxia: 34%, hypoxia-reoxygenation 60% and TNF $\alpha$ : 50%.

LASSO modeling specified 16 markers that effectively distinguished all groups, i.e. the 3 abnormal conditions and control. Bootstrap estimates of misclassification rates, multiclass AUC, and Brier score were 0.108, 0.944, and 0.160, respectively. Using this approach we found previously unknown molecular changes in response to individual PE conditions that allowed development biomolecular signatures for exposure to each accepted pathogenic condition.

### 3.2 Introduction

Preeclampsia (PE) is a disorder of pregnancy characterized by hypertension and proteinuria. Its cause remains unknown. Despite increased understanding of its pathophysiology, PE incidence has increased in the US over the past decade.<sup>1</sup> As many as 75,000 women die worldwide yearly from PE.<sup>2</sup> No established therapeutics exist and efforts to develop such have been hampered by the incomplete explanation of its cause. Currently, when PE cannot be temporized by clinical management, the pregnancy is ended. Typically, there is a rapid resolution of the hypertension, proteinuria and other abnormalities. These findings and substantial other research suggest that the placenta is a necessary for and likely participant in PE.<sup>3</sup> Yet, the specific changes in the placenta that may lead to PE and their antecedent causes are still debated.<sup>4</sup>

Placentae from women with established PE demonstrate many alterations but it is unclear which are part of early PE pathogenesis. Among these, some appear to influence placenta very early to produce PE. These include hypoxia, oxidative stress and increased exposure to pro-inflammatory cytokines.<sup>5-7</sup> These changes are thought to arise from inadequate remodeling of the

maternal vasculature leading to poor placental perfusion.<sup>8</sup> Placentae experiencing hypoxia, oxidative stress or inflammatory cytokines, e.g. tumor necrosis factor- $\alpha$  (TNF $\alpha$ ) initiate a cascade of events leading to maternal features of PE.<sup>5-7</sup> Knowing what effect these factors might have on normal placenta could be used to define specific placental changes that should be evident in PE.

Evaluating molecular changes in placenta has frequently involved proteomic analysis of tissue from women with and without established PE. Common methods primarily identify highly abundant, high molecular weight proteins (HMW), many being structural proteins and chaperones.<sup>9, 10</sup>

The aim of this study was to document molecular changes in placenta with exposure to conditions thought to cause PE. To accomplish this, changes in the abundance of LMW biomolecular placental components were determined by a global, tissue ‘omics’ approach for each condition thought to participate in PE, first demonstrate that changes take place in response to that pathologic state and second to identify a set or signature of molecular responses characteristic of each. This should allow a PE placenta’s composition to define its exposure to early and continued abnormalities.

### 3.3 Materials and methods

#### 3.3.1 Specimen collection

Institutional Review Board approval was obtained from Brigham Young University and Intermountain Health Care to collect human placentae. No patient personal or medical information was recorded in this process and no patient identifiers provided. Thirteen placentas were collected immediately after elective Caesarian section from uncomplicated term pregnancies. A full-thickness (~1-inch square) block of placenta was dissected rapidly midway between the cord

and placental edge, placed on ice and processed within 30 min of delivery. No placenta came from a complicated pregnancy or from women with preexisting disease, e.g. hypertension or diabetes.

### 3.3.2 Sample processing

Fetal membranes and decidua were removed. Explants were collected from the intervillous region representing a point midway between the chorionic and basal plates and ~1 cm thick. After initial washing with ice-cold, sterile PBS, the tissue was cut into thin sections ( $\leq 3$ mm), kept on ice to minimize proteolysis. Slices were washed another 8-10 times until nearly all blood was removed.

### 3.3.3 Explant culture

Tissue (~300 mg) was cultured in 4 mL Dulbecco's Modified Eagle Medium (DMEM) supplemented with 1% penicillin-streptomycin (Sigma-Aldrich, St. Louis, MO). Normal oxygen tension in the intervillous region of placenta has been reported to be 6–8%.<sup>11, 12</sup> This was considered normoxic. All explants were maintained in a modular air chamber (Billups-Rothernberg, Del Mar, CA) filled with 10% oxygen, 5% carbon dioxide, 85% nitrogen for normoxic cultures. The medium was changed after 24 hr, and control or abnormal conditions were imposed for 48 hr.

Each explant was divided into multiple strips, one incubated under ‘normal’ conditions and one for each of the PE associated conditions, termed ‘stressors’ as described below:

**Hypoxia:** Hypoxia was estimated to be 1–2% oxygen for intervillous tissue.<sup>12</sup> For hypoxic treatment, placental explants were exposed to 2% oxygen, 5% CO<sub>2</sub> and 93% N<sub>2</sub>.

**Hypoxia-reoxygenation (H/R):** Placental explants were cultured under hypoxic conditions for 24 hr and then normoxic conditions for 24 hr. H/R results in release of reactive oxygen species (ROS).<sup>6</sup>

**Inflammatory cytokines:** TNF $\alpha$  was added to the culture medium at a final concentration of 5.74 nM with incubations of 48 hrs.<sup>13, 14</sup>

### 3.3.4 Homogenization of placental explants

Following incubation, individual explants were homogenized as described elsewhere.<sup>15</sup> Briefly, 300 mg of placenta were homogenized in the presence of 20  $\mu$ L of protease inhibitor cocktail (P9599, Sigma-Aldrich) plus 20  $\mu$ L of 8.87 mM 1,10-phenanthroline. The homogenate was resuspended in 3 mL PBS and aliquots treated with two volumes of acetonitrile (1:2,v/v). This reduced proteins in the specimen, minimizing ion suppression, allowing for ~7,500-8,000 additional low abundance species to be interrogated using mass spectrometry (MS).<sup>15</sup>

### 3.3.5 Mass spectrometric analysis

After capillary liquid chromatography<sup>15</sup> eluate was introduced into a quadrupole (Q)-time-of-flight (TOF) tandem mass spectrometer (Q-TOFMS) through an electrospray needle (Agilent Technologies 6530 Accurate-Mass Q-TOF/LC/MS). Needle voltage was 3800V and samples were run in the positive ion mode. Mass spectra were collected 8/sec over a mass-to-charge (m/z) range of 400-3000. Data were acquired using MassHunter Data Acquisition B.06.00 and analyzed using Qualitative MassHunter B.06.00 software (Agilent Technologies). Other MS parameters were: gas temperature: 300°C, drying gas flow rate: 5 L/min, nebulizer pressure: 15 psi, fragmentor voltage: 175V, skimmer voltage: 65V.

Time normalization, as described previously,<sup>15</sup> was achieved by defining 2 min windows across the entire LC chromatogram using 11 time markers to define the middle of each elution window. These are summarized below.

Elution windows were evaluated separately. Mass spectra for all samples receiving one treatment were given one color and overlaid with other samples given a second color from the same placentas maintained under control conditions. In overlays peaks that appeared different quantitatively (differences of  $\sim 1.5x$ ) were evaluated statistically. Peak intensities were determined using the 'extract ion count' (XIC) function of the MS software (MassHunter), compiled and statistically tested. For any differentially expressed peak, a nearby peak, representing an endogenous species having comparable abundance under stressed and control conditions was also extracted and peak heights tabulated. These were used as internal references to normalize candidate peaks. In the 11 two-minute windows approximately 7,500-8,000 MS features were observed.

### 3.3.6 Statistical analysis

To reduce the number of potential peaks from which to identify potential biomarkers and to build a classification model, Student's t-test (two-tailed, paired) was performed on each peak in the data set to determine whether the abundance of an extracted peak was different between the control and a given condition. A p-value  $< 0.05$  was considered indicative of a potential biomarker. Any peak with a p-value  $< 0.05$  in any comparison (i.e. controls vs. hypoxia, controls vs. hypoxia-reoxygenation, controls vs. TNF $\alpha$ ) was retained as a possible biomarker for the creation of a classification model.

To build the classification model, LASSO multinomial logistic regression<sup>16</sup> was selected due to its high internal validation performance relative to other methods and its inherent ability to perform peak selection. The final model identified 16 peaks that were effectively able to distinguish the 4 classes of treated placentas (control, hypoxia, hypoxia-reoxygenation, and inflammatory cytokines). Table 3.2A summarizes the selected peaks and model coefficients. On the training data, the model had a correct classification rate of 100%. Note the distinct regions in Figure 3.2 that each group occupies, another indication of model's ability to discriminate between the four treatments (<https://CRAN.R-project.org/package=plot3D>). Since no external data was available for an external validation of the classification model, the performance was assessed through internal validation. To assess overall model performance, we applied the bootstrap method<sup>17</sup> to obtain estimates of the multiclass AUC<sup>18</sup> and the Brier score<sup>19</sup>. We used the .632+ bootstrap method to estimate the misclassification rate.<sup>20</sup> As seen in Table 3.2B, the model is expected to have very good performance. We note that since only the peaks in the list of potential biomarkers were considered in building the final model, the estimates from internal validation are expected to be optimistic. All analyses were performed using R (R Core Team 2015, <https://www.R-project.org/>).

### 3.3.7 Peptide identification

Peptide candidates were submitted to tandem MS fragmentation studies to sequence them using N<sub>2</sub> and sometimes Ar (for poorly fragmenting species) as the collision gas.<sup>15</sup> The acquisition rate for MS/MS experiments was 1 scan/sec and the isolation window was 1.3 m/z for low-charge and 4 m/z for high-charge state peptides.

Due to low initial marker abundance, fragmentation data did not provide complete b- and y-series and *de novo* sequencing was required.

### 3.3.8 Lipid identification

Lipids were fragmented similarly using tandem MS. Databases LIPID Maps (<http://www.lipidmaps.org/>), Metlin (<https://metlin.scripps.edu/>), and Human Metabolome Database (HMDB) (<http://www.hmdb.ca/>) were used to assign lipid structures based on fragment patterns. For markers without matches in databases, elemental composition was predicted by exact mass studies using commercial standards having m/z's 121.0509 and 922.0098 (Agilent Technologies).

## 3.4 Results

### 3.4.1 Chromatographic time alignment

The 11 time normalization peaks are summarized by their m/z, charge state and approximate elution time as follows: 695.09 (z=+4) 17 min, 827.78 (z=+6) 19 min, 474.2 (z=+1) 21 min, 672.36 (z=+3) 23 min, 686.46 (z=+1) 25 min, 1009.05 (z=+1) 27 min, 616.16 (z=+1) 32 min, 526.28 (z=+1) 34 min, 524.36 (z=+1) 37 min, 650.43 (z=+1) 39 min, 675.53 (z=+1) 41 min.

### 3.4.2 Low abundance, LMW weight species altered by PE conditions

Most molecules did not change significantly with treatment. However, several biomolecules changed in response to each treatment. A few changed with more than one. For example,

peptide m/z 827.78 (z=+6) decreased with hypoxia and hypoxia-reoxygenation but not TNF- $\alpha$   
(Figure 3.1.A-B)

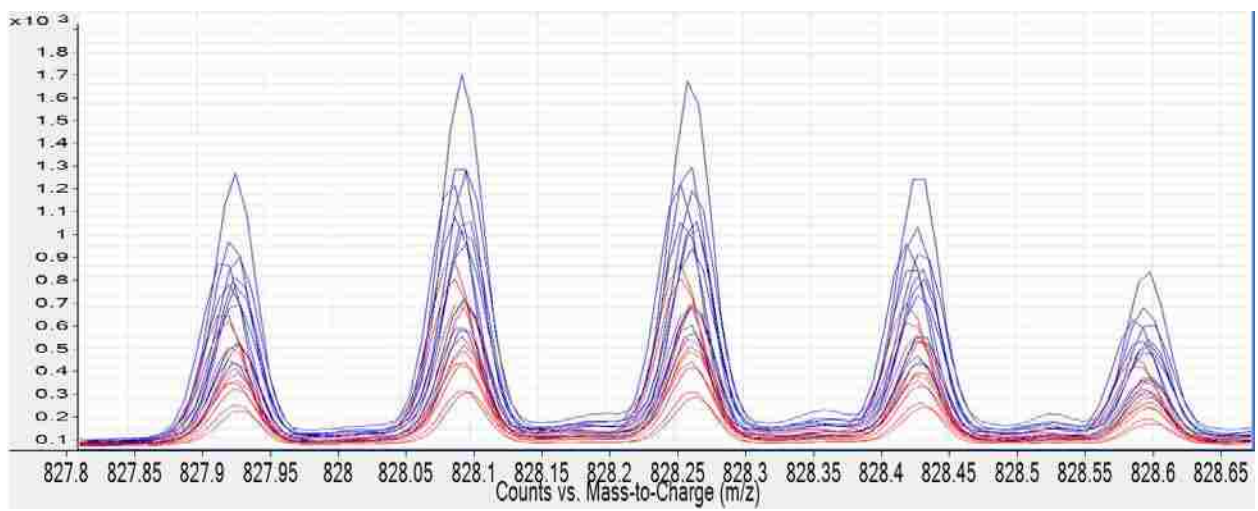



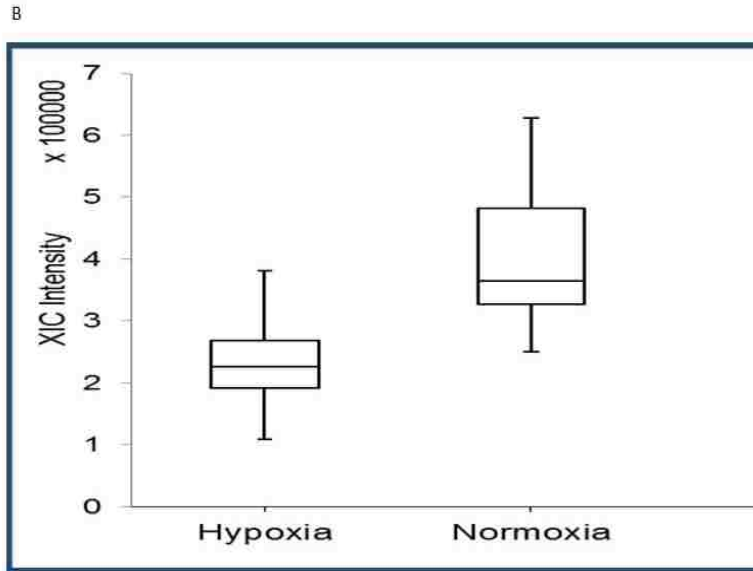

**Figure 3.1. MS overlay and box-and-whisker plot for peptide m/z 827.78 ( $z=+6$ ) A. Overlay of 26 mass spectra in the region containing peptide m/z 827.78 ( $z=+6$ ) with its isotope envelope. Blue, placental explants under control conditions. Red, placental explants under hypoxic conditions. Species less abundant in the hypoxic placental explants. B. Box-and-whisker plot of peptide m/z 827.78 ( $z=+6$ )**

In response to hypoxia significant changes were observed for 75 markers (Table 3.1A). H/R elicited significant changes in 23 molecules (Table 3.1B).  $\text{TNF}\alpha$  caused significant changes in 48 molecules (Table 3.1C). To better understand the biology underlying these changes, tandem MS studies were conducted to chemically classify or identify candidates.

**Table 3.1. List of differentially expressed biomolecules for all the three ‘stressed’ conditions. A. Hypoxia, B. Hypoxia-reoxygenation, C. TNF $\alpha$**

A. Differentially expressed biomolecules in placental explants cultured under hypoxia

<b>M/Z</b>	<b>Z</b>	<b>M+H</b>	<b>P-value</b>	<b>Normalized p-value</b>	<b>Hypoxia</b>	<b>Control</b>
456.17	1	456.17	8.50E-02	3.43E-02	↓	↑
517.03	1	517.03	3.56E-02	3.57E-03	↑	↓
639.33	1	639.33	1.04E-01	4.57E-02	↓	↑
723.22	1	723.22	7.26E-02	1.96E-02	↓	↑
889.57	1	889.57	7.94E-02	2.92E-02	↓	↑
981.43	1	981.43	1.01E-01	3.08E-02	↓	↑
489.61*	3	1466.83	3.67E-02	1.83E-02	↓	↑
643.59*	4	2571.36	5.93E-02	2.87E-02	↓	↑
520.3	5	2597.5	8.07E-03	3.82E-03	↓	↑
574.3	5	2867.5	4.29E-02	2.16E-02	↓	↑

830.4*	6	4977.4	1.44E-03	3.87E-04	↓	↑
478.17	1	478.17	1.29E-03	3.00E-03	↓	↑
495.05	1	495.05	8.78E-02	1.13E-01	↑	↓
512.18	1	512.18	1.03E-02	7.77E-03	↓	↑
545.12	1	545.12	9.85E-04	1.41E-03	↓	↑
570.55	4	2279.2	4.98E-03	5.83E-03	↓	↑
736.08	6	4411.48	1.42E-02	2.79E-02	↓	↑
676.49	7	4729.43	8.69E-04	4.54E-03	↓	↑
694.64	7	4856.48	2.18E-04	7.38E-04	↓	↑
823.26*	6	4934.56	8.31E-03	3.34E-02	↓	↑
827.78*	6	4961.68	5.28E-06	1.08E-04	↓	↑
997.5	5	4983.5	2.04E-03	1.11E-02	↓	↑
1001.9032	5	5005.516	1.06E-03	1.57E-02	↓	↑
1257.62	4	5027.48	5.87E-03	2.93E-02	↓	↑
1012.89*	5	5060.45	3.28E-04	5.64E-03	↓	↑
1271.37	4	5082.48	7.46E-03	4.28E-02	↓	↑
1063.73	5	5314.65	7.80E-02	6.09E-03	↓	↑
1334.9	4	5336.6	4.55E-02	9.65E-03	↓	↑
500.14	10	4992.4	1.25E-02	6.27E-03	↓	↑
405.18	1	405.18	5.74E-02	3.54E-02	↑	↓
425.13	1	425.13	1.66E-03	6.65E-04	↑	↓
431.05	1	431.05	7.45E-02	8.62E-02	↓	↑
447.11	1	447.11	3.04E-04	4.13E-06	↑	↓
469.09	1	469.09	1.17E-02	2.51E-02	↑	↓
504.23	1	504.23	5.51E-03	1.49E-02	↓	↑
736.39	6	4413.34	1.43E-04	1.13E-02	↓	↑
427.18	1	427.18	1.55E-02	4.73E-03	↑	↓
458.25*	1	458.25	2.45E-03	7.80E-04	↓	↑
563.29	1	563.29	8.32E-03	3.61E-03	↓	↑
400.91	3	1200.73	6.33E-05	2.09E-05	↓	↑
401.57	3	1202.71	3.52E-04	9.91E-05	↓	↑
744.49*	11	8179.39	7.71E-05	6.96E-05	↓	↑
711.87	14	9953.18	1.47E-03	1.81E-03	↓	↑
415.19	1	415.19	7.90E-02	1.23E-02	↑	↓
519.27	1	519.27	1.24E-02	1.14E-03	↓	↑
650.97	13	8450.61	5.13E-04	3.29E-04	↓	↑
462.59	3	1385.77	1.01E-02	1.43E-02	↓	↑
868.07	6	5203.42	3.14E-04	6.70E-05	↓	↑
753.52*	7	5269.69	4.53E-02	6.88E-02	↓	↑
893.79	6	5357.74	2.25E-02	7.00E-02	↓	↑
1038.8*	8	8306.22	4.43E-02	1.14E-01	↓	↑

429.19	1	429.19	3.93E-02	8.1E-02	↑	↓
435.19	1	435.19	8.62E-03	2.0E-02	↑	↓
413.19	1	413.19	6.07E-02	0.029	↑	↓
470.74	1	470.74	5.91E-02	4.28E-02	↓	↑
417.33*	1	417.33	3.16E-03	2.79E-04	↓	↑
424.33*	1	424.33	1.27E-03	3.25E-05	↑	↓
431.3*	1	431.3	1.33E-02	1.26E-03	↓	↑
722.41*	1	722.41	5.63E-02	1.33E-02	↓	↑
536.32*	1	536.32	2.26E-02	4.45E-02	↓	↑
616.35	1	616.35	8.87E-02	1.07E-01	↓	↑
622.39*	1	622.39	2.19E-02	6.63E-02	↓	↑
652.41*	1	652.41	4.66E-02	5.04E-02	↓	↑
666.42*	1	666.42	2.67E-02	2.97E-02	↓	↑
688.4*	1	688.4	5.08E-02	4.22E-02	↓	↑
864.54*	1	864.54	6.34E-02	6.22E-02	↓	↑
594.36*	1	594.36	1.34E-02	3.69E-02	↓	↑
414.76	1	414.76	3.84E-02	2.56E-01	↓	↑
423.75	1	423.75	3.15E-02	1.45E-01	↓	↑
452.37*	1	452.37	9.27E-03	9.97E-05	↑	↓
454.38*	1	454.38	8.91E-04	3.46E-06	↑	↓
510.38*	1	510.38	2.99E-02	6.35E-02	↓	↑
480.39*	1	480.39	1.01E-02	7.21E-06	↑	↓
484.43*	1	484.43	2.87E-05	1.05E-06	↑	↓
649.49	1	649.49	3.84E-02	7.57E-03	↑	↓

\*Identified and characterized biomolecules described in Table 3 with their identities.

B. Differentially expressed biomolecules in placental explants cultured under hypoxia-reoxygenation

M/Z	Z	M+H	P-value	Normalized p-value	H/R	Control
538.53*	4	2151.12	6.38E-04	2.41E-03	↓	↑
823.26*	6	4934.56	9.50E-04	2.46E-05	↓	↑
621.07*	8	4961.56	2.40E-06	4.24E-06	↓	↑
623.19	8	4978.52	1.31E-02	8.23E-03	↓	↑
831.58	6	4984.48	2.31E-05	9.64E-06	↓	↑
1012.89*	5	5060.45	3.79E-04	4.36E-04	↓	↑
891.11*	6	5341.66	4.39E-03	9.50E-03	↓	↑
425.13	1	425.13	1.53E-02	2.15E-02	↑	↓

447.11	1	447.11	9.69E-04	2.70E-03	↑	↓
435.27	3	1303.81	8.30E-02	5.37E-02	↑	↓
458.25*	1	458.25	9.44E-03	8.0E-03	↓	↑
659.51	12	7903.12	3.23E-04	4.5E-03	↓	↑
555.78	1	555.78	1.58E-03	3.14E-02	↓	↑
558.28	1	558.28	5.96E-02	2.66E-02	↓	↑
506.83	2	1012.66	7.78E-02	7.60E-02	↓	↑
462.59	3	1385.77	3.43E-02	8.91E-03	↓	↑
451.74	1	451.74	3.85E-02	1.46E-02	↓	↑
431.31	1	431.31	4.27E-04	3.39E-04	↓	↑
542.31*	1	542.31	7.87E-02	2.86E-02	↑	↓
590.32*	1	590.32	7.81E-03	1.01E-02	↑	↓
566.37	1	566.37	8.16E-02	5.33E-03	↓	↑
426.35*	1	426.35	2.47E-02	3.02E-03	↑	↓
401.26*	1	401.26	4.30E-03	2.47E-03	↑	↓

\*Identified and characterized biomolecules described in Table 3 with their identities.

C. Differentially expressed biomolecules in placental explants cultured in TNF $\alpha$  environment

<b>M/Z</b>	<b>Z</b>	<b>M+H</b>	<b>P-value</b>	<b>Normalized p-value</b>	<b>TNF<math>\alpha</math></b>	<b>Control</b>
461.06	1	461.06	4.46E-02	1.08E-01	↑	↓
501.19	1	501.19	5.90E-02	1.13E-01	↓	↑
517.03	1	517.03	5.03E-02	2.96E-02	↑	↓
525.28	1	525.28	1.53E-02	5.37E-01	↓	↑
661.29	1	661.29	9.88E-02	2.25E-01	↓	↑
705.24	1	705.24	5.47E-02	7.35E-01	↓	↑
830.4	6	4977.4	1.83E-02	1.16E-01	↓	↑
619.27	1	619.27	5.08E-02	6.49E-02	↓	↑
409.29	1	409.29	1.10E-02	6.81E-03	↓	↑
427.3	1	427.3	1.22E-02	6.38E-03	↓	↑
629.3	1	629.3	9.55E-02	8.91E-02	↓	↑
673.25	1	673.25	7.73E-02	9.43E-02	↓	↑

801.39	1	801.39	3.33E-02	4.92E-02	↓	↑
853.59	1	853.59	8.76E-03	7.17E-03	↓	↑
832.59	6	4990.54	3.72E-02	4.17E-03	↑	↓
505.25	1	505.25	1.06E-02	8.58E-03	↓	↑
549.27	1	549.27	3.67E-02	9.29E-03	↓	↑
584.94	1	584.94	3.75E-03	3.79E-04	↑	↓
586.97	1	586.97	5.79E-03	2.56E-04	↑	↓
666.14*	5	3326.7	4.77E-02	1.32E-02	↑	↓
458.25*	1	458.25	1.09E-03	4.29E-04	↑	↓
479.25	1	479.25	1.17E-02	1.16E-01	↑	↓
773.15	1	773.15	4.90E-03	1.56E-02	↓	↑
460.27	2	919.54	6.88E-02	7.80E-02	↑	↓
409.16	1	409.16	2.12E-02	3.83E-02	↓	↑
467.12	1	467.12	3.20E-02	3.78E-02	↓	↑
476.24	1	476.24	1.32E-02	2.00E-03	↑	↓
590.22	1	590.22	3.29E-03	5.19E-03	↓	↑
454.28*	1	454.28	6.26E-03	1.10E-01	↑	↓
460.24	1	460.24	1.51E-02	1.22E-01	↑	↓
474.25	1	474.25	1.78E-02	7.42E-02	↑	↓
476.27*	1	476.27	4.63E-02	2.00E-01	↑	↓
494.31*	1	494.31	6.17E-03	2.37E-02	↑	↓
500.27	1	500.27	5.26E-03	2.59E-02	↑	↓
540.25	1	540.25	7.44E-03	4.51E-02	↑	↓
518.31*	1	518.31	9.69E-02	2.37E-01	↑	↓
478.29*	1	478.29	5.05E-03	1.18E-02	↑	↓
480.38	1	480.38	1.62E-02	1.58E-02	↑	↓
520.33*	1	520.33	6.58E-03	1.17E-02	↑	↓
522.33*	1	522.33	1.78E-02	1.43E-02	↑	↓
542.31*	1	542.31	7.53E-03	9.05E-03	↑	↓
544.33*	1	544.33	2.36E-02	2.10E-02	↑	↓
566.32*	1	566.32	6.80E-03	9.23E-03	↑	↓
568.33*	1	568.33	3.12E-02	2.48E-02	↑	↓
997.61*	1	997.81	3.16E-02	1.43E-02	↑	↓
1045.65*	1	1045.65	1.86E-02	1.86E-02	↑	↓
1504.85*	1	1504.85	4.58E-02	4.05E-02	↑	↓
1021.61	1	1021.61	8.53E-02	6.09E-02	↑	↓
502.28*	1	502.28	2.99E-02	5.17E-02	↑	↓
425.28	1	425.28	2.45E-02	2.47E-02	↑	↓

\*Identified and characterized biomolecules described in Table 3 with their identities.

### 3.4.3 Sequenced peptides

Most stress-responsive peptides had charge states  $>+3$  and presented at low abundance and/or with post-translational modifications (PTMs). Sequences were evaluated by on-line database comparison (Mascot ([http://www.matrixscience.com/search\\_form\\_select.html](http://www.matrixscience.com/search_form_select.html), Spectrum Mills) but ultimately required *de novo* sequencing.

As an example, peptide  $m/z$  744.49,  $z=+11$  was a ubiquitin peptide based on two partial *de novo* amino acid sequences submitted to a BLAST search. Several fragments could be assigned to the y-ion series, but none matched the predicted b-series. There was an offset of 132.04 mass units suggesting a pentose modification. After adding this modification to the b1 ion, glutamine, many  $m/z$ 's observed in the fragment spectrum then matched predicted ions in the b-series.

Glutamine has not been reported to have a pentose modification, but the b1-b4 ions had the modification present suggesting the modification.

#### 3.4.4 Lipid classification

All lipids were in the +1 charge state. Certain lipids were readily classified by fragments, e.g. Phosphatidylcholines (PCs) and phosphoethanolamines (PEts) showed signature peaks at  $m/z$  184.07 or a neutral loss of 141.03 respectively. Additionally acylcarnitines had signature peaks at  $m/z$  60.04 and 85.02.

Other lipid molecules, e.g. vitamin D<sup>21</sup> and 10,11-Dihydro-12R-hydroxy-leukotriene E4<sup>22</sup> were assigned based on accurate masses and characteristic water losses. These assignments were confirmed by prior literature.<sup>21, 22</sup>

Several PCs appeared oxidized, probably at double bonds. Oxidized PCs typically showed one or two water loss peaks (-18 and -36 mass units) from the precursor ion upon fragmentation. Some were confirmed using LIPID MAPS while others were confirmed using exact mass studies.

Two markers appeared to be dimers of PC and PE and one a trimer of PE based on fragmentation patterns. For a dimer of PC and PE, a very abundant peak at the PC's  $m/z$  was present accompanied by an abundant 184.07 peak. A smaller peak representing a PE was also present. In all three cases it was PE  $m/z$  502.28 with neutral loss of 141.01 manifest by a peak at  $m/z$  361.27 for all 3 markers. These assignments were confirmed by exact mass studies.



### 3.4.5 Condition specific signatures

A final model identified 16 peaks that effectively segregated the 4 placental treatments (control, hypoxia, hypoxia-reoxygenation, TNF $\alpha$ ) (Table 3.2A). On the training data, the model had a correct classification rate of 100% (Figure 3.2). The X, Y, and Z axes are not orthogonal, but represent linear combinations of the model coefficients of Controls, Hypoxia, and Hypoxia-Reoxygenation treatments, respectively. Bootstrap estimates of misclassification rates, multiclass AUC, and Brier score were 0.108, 0.944, and 0.160, respectively, suggesting very good performance (Table 3.2B). However, because not all molecules were used for analysis (only significant ones), the estimates may be optimistic.



**Figure 3.2. Scatterplot of Group Membership Based on the Statistical Model. The numbers, 1, 2, 3, and 4, correspond to the Controls, Hypoxia, Inflammatory Cytokines, and Hypoxia-Reoxygenation classes, respectively. The x, y, and z axes, which are not constrained to be orthogonal, represent the predicted probabilities from the lasso model for the Controls, Hypoxia, and Hypoxia-Reoxygenation treatment classes, respectively.**

**Table 3.2. Condition specific changes in biomolecules**

3.2A. Non-zero Peaks (M+H value) and Coefficients from Lasso Multinomial Logistic Regression Model

Class		M+H Peak Values and Coefficients									
		Control	Peak Coefficient	Intercept -2.382	431.3 25.278	452.75 -3.309	484.43 -5.226	1218.73 0.143	2151.12 296.642	2571.36 0.00013	4934.56 1.129
Hypoxia	Peak Coefficient	Intercept 0.449	425.13 0.0051	447.11 0.006	452.75 12.911	478.17 -35.301	484.43 6.873	512.18 -0.417	2151.12 -	2571.36 122.656	0.00004 8
TNF- $\alpha$	Peak Coefficient	Intercept 2.561	2571.3 6 -0.0001	4934.5 6 -0.633	4977.4 6 0.766	5082.48 -29.168					
Hypoxia- Reoxygen- ation	Peak Coefficient	Intercept -0.627	2571.3 6 - 0.0000 5	3326.7 0.0016	5341.6 6 2.234	7903.12 -0.0991					

3.2B. Model Performance Based on Internal Validation

Misclassification Rate	AUC	Brier
0.108	0.944	0.160

### 3.5 Discussion

The cause of PE remains elusive. Current research implicates the placenta in its pathogenesis. The best documented PE abnormalities experienced by the placenta are hypoxia or H/R or exposure to pro-inflammatory cytokines.<sup>5-7</sup>

This study tested two hypotheses. First, it was proposed that normal placental explants exposed to PE abnormalities would show significant changes in LMW cellular components, and second, that each abnormality would produce a specific pattern of changes. If these hypotheses proved true, then it might be possible to find these same patterns in actual PE placenta and thus provide evidence for a specific abnormality being part of that pregnancy. When hypoxia, H/R or TNF $\alpha$  was presented to human placental explants, several LMW peptides and lipids demonstrated significant changes for each. Some changed in response to all three abnormalities, but most changed in response to only one, suggesting more stressor-specific changes.

Others have studied the placenta as related to PE using cell culture.<sup>23</sup> Those studies employed choriocarcinoma cells and may have limitations due to the use of cancer cells. Explanted tissue, as used here, is also imperfect, but begins with normal placental tissue and maintains the native tissue architecture. This may preserve important processes including cell-to-cell communication and may be closer to the in-vivo environment. As a practical consideration, tissue provides more material to work with, allowing for better MS coverage of low abundance species.

There are many ‘omics’ methods. Some have been applied to PE placenta, primarily 2-DGE with excision of differentially expressed proteins, trypsin digestion followed by MS.<sup>24</sup> This identifies full length proteins, but surveys only dozens to a few hundred more abundant species,

omitting less abundant proteins and all peptides and lipids. More comprehensive, global proteomics methods exist and increase the number of proteins surveyed. They have been applied to trophoblast cells or secreted products of trophoblast cells after labeling.<sup>25</sup> They still measure the more abundant proteins and omit low abundance proteins, peptides and lipids. A few studies targeting specific proteins or metabolites using immunoassays or MS have been reported.<sup>26, 27</sup>

Our study, in contrast, focused on less abundant, LMW biomolecules using a global tissue ‘omics’ approach. There is a greater recognition that smaller, less abundant molecules contribute to cell physiology.<sup>28</sup> Obviously, interrogation of them will provide a more complete picture of tissue biology. A second novel aspect of this work is in defining sets of molecular changes that indicate placental exposure to specific preeclamptic stress conditions. This may provide biological insights into placental responses but can provide a molecular signature unique to each abnormality. These signatures may be usefully compared with similarly obtained ‘omic’ profiles found in PE placenta to potentially define the pathologic background of that placenta.

As predicted, several peptides and lipid molecules changed in response to each PE abnormality

The responses to a specific PE condition were consistent across placentae and often more than one molecule having similar structure or biologic function changed in concert increasing the likelihood that changes were real. Additionally, several of the significant biomarkers in our study have been linked with PE previously in the literature. Again, this consistency further suggests their involvement in the pathophysiology of PE.

The responding markers are organized by function in Table 3.3. This categorization is similar to a systems biology approach in which several related biological pathways appear to change in a uniform direction in response to a particular stress.

**Table 3.3. Summary of categorized markers with their identifications and biological significance**

Cytoskeletal elements					
m/z	Parent protein	Stress	Higher in	Sequence <sup>c</sup>	Biological pathways
489.61 (+3)	Vimentin	Hyp <sup>a</sup>	Ctr <sup>b</sup>	slplvdthskrtl	Vimentin helps regulate and stabilize cell adhesion. Vimentin fragments in PE remain unstudied. Keratin plays a role in implantation and placentation. <sup>29</sup> Under biological stress, degradation of keratin occurs <sup>30</sup> with fragments entering the maternal circulation. <sup>31</sup>
643.59 (+4)	Keratin-8 acetylated (position of modification -unknown)	Hyp	Ctr	sirvtqksykvstsgp rafssrs	
830.4 (+6)	Acetylated at N termini-Thymosin B-4(oxidized at methionine-6)	Hyp, H/R, TNF $\alpha$	Ctr	(Ac) <sup>d</sup> sdkpdm(Ox) <sup>e</sup> aeiekfdk-skllkktetqeknplps ketieqekqages	Thymosin appears cytoprotective and angiogenic in pregnancy, <sup>32</sup> but is unstudied in PE. Our findings differ from one study that found increased thymosin b4 in a hypoxic mouse model. <sup>33</sup> Cells in that study were exposed to 1 hr Hyp. Differences in time, tissue, species might account for different findings. The oxidized methionine form of thymosin b-4 may have anti-inflammatory properties. <sup>34</sup>
823.26 (+6)	Thymosin Beta-10 (Acetylated at N termini)	Hyp & H/R	Ctr	(Ac)ad-kpdmgeiasfdkaki kktetqekntlpt-ketieqekrseis	
827.78 (+6)	Thymosin Beta-4 (Acetylated at N termini)	Hyp & H/R	Ctr	(Ac)sdkpdmaeie kfdk-skllkktetqeknplps ketieqekqages	
1012.89 (+5)	Thymosin Beta-4 (Acetylated at N termini; phosphorylated)	Hyp & H/R	Ctr	Sdkpdmaeiekfdk skllkktetqeknplps ketieqekqages	
891.11 (+6)	thymosin beta 4+380.16	H/R	Ctr		

538.53 (+4)	Fragment of Thymosin B-4 (acetylated at N)	H/R	Ctr	sdkpdmaeiekfdk-skllk	
<b>Hemoglobin</b>					
m/z	ID	Stressor	Higher in	Sequence	Biological pathways
753.52 (+7)	Hgb <sup>f</sup> alpha 1 globin chain	Hyp	Ctr	vlspadktn vkaaw-gkvga hageygaeal ermflsfptt ktyfphfdl	Unknown
1038.89 (+8)	Hgb alpha 1 globin chain	Hyp	Ctr	vlspadktn vkaaw-gkvga hageygaeal ermflsfptt ktyfphfdls hgsaqvkghgkkvadalt n a vahvddmpn	
666.14 (+5)	Hgb alpha 1 globin chain	TNF $\alpha$	TNF $\alpha$	vlspadktnvkaaw-gkvga hageygaealerm	
<b>Ubiquitin</b>					
m/z	ID	Stressor	Higher in	Sequence	Biological pathways
744.49 (+11)	Ubiquitin (Pentose modification at b1)	Hyp	Ctr	qifvktltgk-titlevepsdtien-vkakiqdkegippdqqrli-fagkqledgrtldyn iqkestlhlvlr	Hypoxia-inducible factor 1a (HIF-1a) levels are normally low due to its degradation by the ubiquitin system. <sup>35</sup> Under hypoxic conditions, HIF-1a has a longer half-life and increased levels due to decreased ubiquitination. <sup>35</sup>
<b>Inflammatory Factors</b>					
m/z	ID	Stressor	Higher in	Chemical composition [M+H]	Biological pathways
458.25 (+1)	10,11-Dihydro-12R-hydroxy-leukotriene E4	Hyp, H/R, TNF $\alpha$	Ctr TNF $\alpha$	C <sub>23</sub> H <sub>40</sub> NO <sub>6</sub> S	This compound is an oxidized metabolite of LTE4, a mediator of inflammation, <sup>36</sup> and its reduction with Hyp and H/R may

	(LTE4)(Epsilon-LTB(,3))				be due to limited oxygen, while the over-expression with exposure to TNF $\alpha$ may cause deleterious effects. <sup>37</sup>
<b>Metabolic mediators</b>					
m/z	ID	Stressor	Higher in	Chemical composition [M+H]	Biological pathways
417.33 (+1)	Dihydroxyvitamin D3	Hyp	Ctr	C <sub>27</sub> H <sub>45</sub> O <sub>3</sub>	Active dihydroxyvitamin D3 helps with decidualization and implantation in pregnancy. <sup>38</sup> Decreased synthesis of D3 produces more Th1 type cytokines adversely affecting the pregnancy. <sup>39</sup> PE is associated with low levels of D3. <sup>39</sup>
<b>Fatty acid metabolism</b>					
m/z	ID	Stressor	Higher in	Chemical composition [M+H]	Biological pathways
424.33 (+1)	Fatty acyl carnitines 9,12-Hexadecadienylcarnitine	Hyp	Hyp	C <sub>25</sub> H <sub>46</sub> NO <sub>4</sub>	Carnitine shuttles fatty acids into the mitochondrial matrix for $\beta$ -oxidation. Oxygen is required for active electron. Hyp decreases electron transport increasing NADH and FADH <sub>2</sub> . <sup>40</sup> This results acyl-carnitines accumulation. <sup>41</sup> Studies report increased acyl-carnitines in PE. <sup>42</sup>
452.37 (+1)	Fatty acyl carnitines (11Z,14Z)-eicosadienylcarnitine	Hyp	Hyp	C <sub>27</sub> H <sub>50</sub> NO <sub>4</sub>	
454.38 (+1)	Fatty acyl carnitines (11Z)-eicosenoylecarnitine	Hyp	Hyp	C <sub>27</sub> H <sub>52</sub> NO <sub>4</sub>	
480.39 (+1)	Fatty acyl carnitines (13Z,16Z)-docosadienylcarnitine	Hyp	Hyp	C <sub>29</sub> H <sub>54</sub> NO <sub>4</sub>	
484.43 (+1)	Fatty acyl carnitines	Hyp	Hyp	C <sub>29</sub> H <sub>58</sub> NO <sub>4</sub>	



	O-behenoylcarnitine				
426.35 (+1)	Fatty acyl carnitines O-oleoylcarnitine	H/R	H/R	C <sub>25</sub> H <sub>48</sub> NO <sub>4</sub>	
<b>Phosphatidylcholines</b>					
m/z	ID	Stressor	Higher in	Chemical composition [M+H]	Biological pathways
722.41 (+1)	Either an oxidized PC or normal	Hyp	Ctr	C <sub>38</sub> H <sub>61</sub> NO <sub>10</sub> P or C <sub>42</sub> H <sub>61</sub> NO <sub>7</sub> P	Hyp may reduce PC synthesis due to less ATP. <sup>43, 44</sup> Our studies found increases in several lyso-PCs and lyso-PEs in placenta presented with H/R and TNF $\alpha$ . This is consistent with previous findings of increased phospholipase A <sub>2</sub> activity in both these conditions with increased lyso-PC and lyso-PE. <sup>45, 46</sup> Others report higher phospholipase A <sub>2</sub> activity in PE. <sup>47</sup>
536.32 (+1)	PC (16:1/2:0) <sup>g</sup>	Hyp	Ctr	C <sub>26</sub> H <sub>51</sub> NO <sub>8</sub> P	
594.36 (+1)	Oxidized PC(16:0/5:0(CHO) )	Hyp	Ctr	C <sub>29</sub> H <sub>57</sub> NO <sub>9</sub> P	
622.39 (+1)	Oxidized PC (Not on any lipid databases)	Hyp	Ctr	C <sub>31</sub> H <sub>61</sub> NO <sub>9</sub> P	
652.41 (+1)	Oxidized PC (Not on any lipid databases)	Hyp	Ctr	C <sub>32</sub> H <sub>63</sub> NO <sub>10</sub> P	
666.42 (+1)	Oxidized PC (16:0/9:0(COOH))	Hyp	Ctr	C <sub>33</sub> H <sub>65</sub> NO <sub>10</sub> P	
688.4 (+1)	Sodiated Oxidized PC [M+Na] for m/z 666.42	Hyp	Ctr	C <sub>33</sub> H <sub>64</sub> NO <sub>10</sub> NaP	
864.54 (+1)	Oxidized PC (Not on any lipid databases)	Hyp	Ctr	C <sub>48</sub> H <sub>83</sub> NO <sub>10</sub> P	
510.38 (+1)	LPC <sup>h</sup> (O-18:0/0:0)	Hyp	Ctr	C <sub>26</sub> H <sub>57</sub> NO <sub>6</sub> P	
566.31 (+1)	M+Na of 544.33 LPC(20:4/0:0)	H/R	H/R	C <sub>28</sub> H <sub>50</sub> NO <sub>7</sub> NaP	

590.32 (+1)	M+Na of 568.33 LPC(22:6/0:0)	H/R	H/R	C <sub>30</sub> H <sub>50</sub> NO <sub>7</sub> NaP	
542.31 (+1)	M+Na of 520.33 LPC(18:2/0:0)	H/R	H/R	C <sub>26</sub> H <sub>50</sub> NO <sub>7</sub> NaP	
494.31 (+1)	LPC (16:1/0:0)	TNF $\alpha$	TNF $\alpha$	C <sub>24</sub> H <sub>49</sub> NO <sub>7</sub> P	
518.31 (+1)	M+Na of 496.33 LPC (16:0/0:0)	TNF $\alpha$	TNF $\alpha$	C <sub>24</sub> H <sub>50</sub> NO <sub>7</sub> NaP	
520.33 (+1)	LPC (18:2/0:0)	TNF $\alpha$	TNF $\alpha$	C <sub>26</sub> H <sub>51</sub> NO <sub>7</sub> P	
522.33 (+1)	LPC (18:1/0:0)	TNF $\alpha$	TNF $\alpha$	C <sub>26</sub> H <sub>53</sub> NO <sub>7</sub> P	
542.31 (+1)	M+Na of 520.33 LPC (18:2/0:0)	TNF $\alpha$	TNF $\alpha$	C <sub>26</sub> H <sub>50</sub> NO <sub>7</sub> NaP	
544.33 (+1)	LPC (20:4/0:0)	TNF $\alpha$	TNF $\alpha$	C <sub>28</sub> H <sub>51</sub> NO <sub>7</sub> P	
566.32 (+1)	M+Na of 544.33 LPC (20:4/0:0)	TNF $\alpha$	TNF $\alpha$	C <sub>28</sub> H <sub>50</sub> NO <sub>7</sub> NaP	
568.33 (+1)	LPC (22:6/0:0)	TNF $\alpha$	TNF $\alpha$	C <sub>30</sub> H <sub>51</sub> NO <sub>7</sub> P	
<b>Phosphatidylethanolamine</b>					
m/z	ID	Stressor	Higher in	Chemical composition [M+H]	
454.28 (+1)	LPE <sup>i</sup> (16:0/0:0)	TNF $\alpha$	TNF $\alpha$	C <sub>21</sub> H <sub>45</sub> NO <sub>7</sub> P	
476.27 (+1)	LPE (18:3/0:0)	TNF $\alpha$	TNF $\alpha$	C <sub>23</sub> H <sub>43</sub> NO <sub>7</sub> P	
478.28 (+1)	LPE (18:2/0:0)	TNF $\alpha$	TNF $\alpha$	C <sub>23</sub> H <sub>45</sub> NO <sub>7</sub> P	
500.27 (+1)	LPE (20:5/0:0)	TNF $\alpha$	TNF $\alpha$	C <sub>25</sub> H <sub>43</sub> NO <sub>7</sub> P	

474.25 (+1)	M+Na of 452.26 PE (16:1/0:0)	TNF $\alpha$	TNF $\alpha$	C <sub>21</sub> H <sub>42</sub> NO <sub>7</sub> NaP	
478.29 (+1)	LPE (18:2/0:0)	TNF $\alpha$	TNF $\alpha$	C <sub>23</sub> H <sub>45</sub> NO <sub>7</sub> P	
502.28 (+1)	LPE (20:4/0:0)	TNF $\alpha$	TNF $\alpha$	C <sub>25</sub> H <sub>45</sub> NO <sub>7</sub> P	
480.3 (+1)	LPE (18:1/0:0)	TNF $\alpha$	TNF $\alpha$	C <sub>23</sub> H <sub>47</sub> NO <sub>7</sub> P	
558.35 (+1)	PEt (Not on any lipid databases)	H/R	H/R	C <sub>29</sub> H <sub>53</sub> NO <sub>7</sub> P	

### Element composition of unknown markers

m/z	ID	Stressor	Higher in	Chemical composition [M+H]	Biological pathways
431.31 (+1)	Unknown	Hyp	Ctr	C <sub>27</sub> H <sub>43</sub> O <sub>4</sub>	Unknown
401.26 (+1)		H/R	H/R	C <sub>25</sub> H <sub>37</sub> O <sub>4</sub>	
409.16 (+1)		TNF $\alpha$	Ctr	C <sub>24</sub> H <sub>25</sub> O <sub>6</sub>	

### Dimers

m/z	ID	Stressor	Higher in	Biological pathways
1045.61 (+1)	Dimer of 543.33 PC(20:4) and 501.28 LPE (20:4)	TNF $\alpha$	TNF $\alpha$	Unknown

997.61 (+1)	Dimer of 495.33 PC (16:0) and LPE (20:4)	TNF $\alpha$	TNF $\alpha$	
1504.85	Trimer of 501.28 LPE (20:4), 525.28 LPE (22:6/0:0) and 477.28 LPE (18:2/0:0)	TNF $\alpha$	TNF $\alpha$	

<sup>a</sup>Hypoxia; <sup>b</sup>Control; <sup>c</sup>Sequence represents amino acid composition of the peptide identified; <sup>d</sup>(Ac) represents a post-translation modification (PTM) by acetylation at b1; <sup>e</sup>(Ox) represents a PTM by oxidation; <sup>f</sup>Hemoglobin; <sup>g</sup>The annotation (e.g. PC(16:1/2:0)) describes the number of carbon atoms in the fatty acid chain with the number of double bonds. In this case, the fatty acid is composed of 16 carbons with one double bonds at the sn-1 position of the glycerol backbone, whereas 2:0 represents the 2 carbons with zero double bonds at sn-2 position; <sup>h</sup>Lysophosphatidylcholine; <sup>i</sup>Lysophosphoethanolamine

Among these related, responding compounds were cytoskeletal components including fragments of vimentin and keratin-8 which were decreased in response to hypoxia. Several molecules derived from thymosin B4 or B10 were also decreased with hypoxia and H/R. Wen et al. found decreased circulating levels of thymosin B4 peptide in the serum of preeclamptic women.<sup>48</sup> This peptide's downregulation may or may not be related to hypoxia, but the consistent trend is suggestive.

Additionally, there was at least one inflammatory factor, 10,11-dihydro-12R-hydroxy-leukotriene E4, was decreased in response to hypoxia and H/R. Interestingly, this same factor was increased in response to TNF $\alpha$  as reported by others.<sup>37</sup>

In our studies, levels of 1,25 dihydroxy-vitamin D3 were significantly reduced in response to hypoxia, consistent with trends seen in PE.<sup>39</sup>

Conditions applied to normal placenta changed features of fatty acid metabolism. Increased acyl-carnitines occurred with hypoxia and H/R. Similar changes have been reported in hypoxic tissues and in PE.<sup>42</sup>

There were several changes in PCs and PEs. There were decreased PCs with hypoxia, consistent with published studies.<sup>43, 44</sup> In contrast there were increases in several lyso-PCs and lyso-PEts with H/R or TNF $\alpha$ , also consistent with previous reports.<sup>45, 46</sup> Three markers increased by TNF $\alpha$  were dimers or a trimer of PCs and PEts. The PEt common to all three differentially expressed molecules was lyso-PEt (20:4), also increased in TNF $\alpha$ -exposed placental explants. Small amounts of lipid dimers may be formed in the ESI source<sup>49, 50</sup> although other data suggests that they are also present endogenously.<sup>51</sup>

Not all statistically significant markers were identified for several reasons: 1) The abundance was too low for adequate fragment coverage. 2) High charge states of peptides make identification exceptionally difficult. This accompanied with their low initial abundance, post-translational modifications, peak overlap left fragment series incomplete or uninterpretable. 3) Having little or no fragmentation precluded classification or component identification. Some fragments were unrecognized in the current, limited lipid databases. For these, exact mass studies were performed to predict elemental composition.

The second hypothesis in our studies was that there would be changes in LMW components of placenta unique to each of the three applied PE conditions. Even among the most responsive molecules, there was some degree of overlap between control and stressed placenta and between the three conditions also. The Venn diagram in Figure 3.3 represents the extent of overlap. To address the uniqueness to each PE condition, combinations of significantly different molecules were statistically modeled using LASSO. This resulted in several combinations able to distinguish each abnormal condition imposed uniquely, a stress-specific molecular signature. This satisfied our second hypothesis and should allow for evaluation of PE placenta to determine their exposure to a particular stress.

In conclusion, these studies demonstrated the ability of a global ‘omics’ method, focused on low molecular weight, low abundance species, to track the placenta’s response to abnormalities considered participatory in PE and to develop signatures for each. These appear to provide insights in pathology and may allow for identifying underlying pathology in PE placenta.

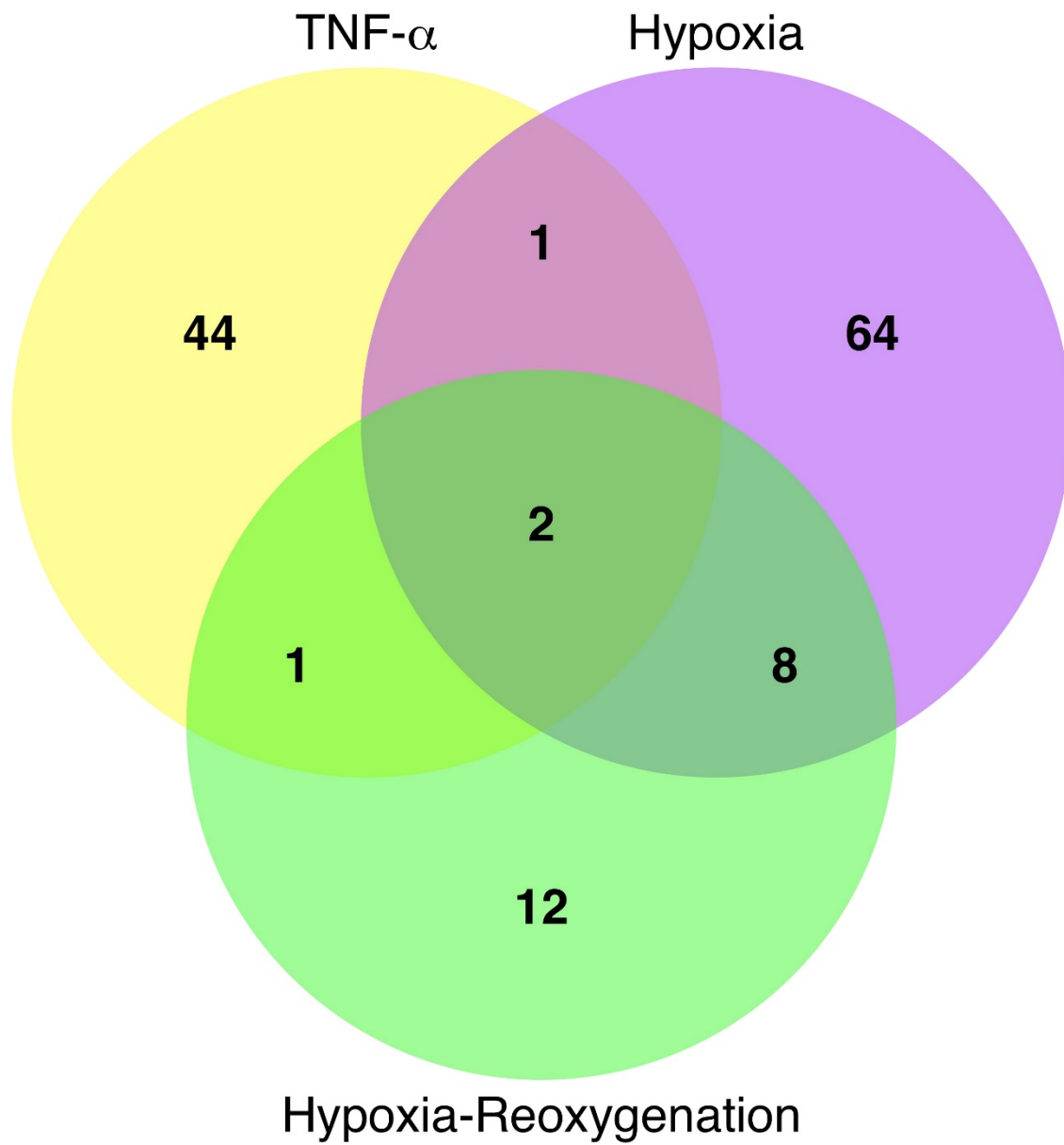

**Figure 3.3. Venn diagram to represent the overlap in biomarkers between the three PE conditions applied on placental explants.**

### 3.6 References

1. Ananth, C. V.; Keyes, K. M.; Wapner, R. J., Pre-eclampsia rates in the United States, 1980-2010: age-period-cohort analysis. *Brit. Med. J.* **2013**, *347* (7937), 1-14.
2. Zeng, B.; Kwak-Kim, J.; Liu, Y.; Liao, A.-H., Treg Cells Are Negatively Correlated with Increased Memory B Cells in Pre-eclampsia While Maintaining Suppressive Function on Autologous B-Cell Proliferation. *Am. J. Reprod. Immunol.* **2013**, *70* (6), 454-463.
3. Singh, H. J., Pre-Eclampsia: Is It All In The Placenta? *Malays. J. Med. Sci.* **2009**, *16* (1), 7-15.
4. Wang, Y.; Alexander, J. S., Placental pathophysiology in preeclampsia. *Pathophysiology* **2000**, *6* (4), 261-270.
5. Soleymanlou, N.; Jurisica, I.; Nevo, O.; Ietta, F.; Zhang, X.; Zamudio, S.; Post, M.; Caniggia, I., Molecular Evidence of Placental Hypoxia in Preeclampsia. *J. Clin. Endocrinol. Metab.* **2005**, *90* (7), 4299-4308.
6. Hung, T.-H.; Burton, G. J., Hypoxia and Reoxygenation: a Possible Mechanism for Placental Oxidative Stress in Preeclampsia. *Taiwan. J. Obstet. Gynecol.* **2006**, *45* (3), 189-200.
7. Conrad, K. P.; Benyo, D. F., Placental cytokines and the pathogenesis of preeclampsia. *Am. J. Reprod. Immunol.* **1997**, *37* (3), 240-9.
8. Powe, C. E.; Levine, R. J.; Karumanchi, S. A., Preeclampsia, a disease of the maternal endothelium: the role of anti-angiogenic factors and implications for later cardiovascular disease. *Circulation* **2011**, *123* (24), 2856-2869.
9. Robinson, J. M.; Vandre, D. D.; Ackerman, W. E. t., Placental proteomics: a shortcut to biological insight. *Placenta* **2009**, *30* (9), 13.



10. Centlow, M.; Hansson, S. R.; Welinder, C., Differential proteome analysis of the preeclamptic placenta using optimized protein extraction. *Biomed. Res. Int.* **2009**, *2010*.
11. Gauster, M.; Siwetz, M.; Orendi, K.; Moser, G.; Desoye, G.; Huppertz, B., Caspases rather than calpains mediate remodelling of the fodrin skeleton during human placental trophoblast fusion. *Cell Death Differ.* **2009**, *17* (2), 336-345.
12. Dunn, W. B.; Brown, M.; Worton, S. A.; Crocker, I. P.; Broadhurst, D.; Horgan, R.; Kenny, L. C.; Baker, P. N.; Kell, D. B.; Heazell, A. E., Changes in the metabolic footprint of placental explant-conditioned culture medium identifies metabolic disturbances related to hypoxia and pre-eclampsia. *Placenta* **2009**, *30* (11), 974-80.
13. Wagner, P. K.; Otomo, A.; Christians, J. K., Regulation of pregnancy-associated plasma protein A2 (PAPPA2) in a human placental trophoblast cell line (BeWo). *Reprod. Biol. Endocrinol.* **2011**, *9*, 48.
14. Ma, J.; Esplin, M. S.; Adair, C. D.; Mason, L. A.; Graves, S. W., Increasing Evidence for and Regulation of a Human Placental Endogenous Digitalis-Like Factor. *Reprod. Sci.* **2012**, *19* (4), 437-448.
15. Kedia, K.; Nichols, C. A.; Thulin, C. D.; Graves, S. W., Novel "omics" approach for study of low-abundance, low-molecular-weight components of a complex biological tissue: regional differences between chorionic and basal plates of the human placenta. *Anal. Bioanal. Chem.* **2015**, *407* (28), 8543-56.
16. Friedman, J.; Hastie, T.; Tibshirani, R., Regularization Paths for Generalized Linear Models via Coordinate Descent. *Journal of statistical software* **2010**, *33* (1), 1-22.

17. Harrell, F. E., Jr.; Lee, K. L.; Mark, D. B., Multivariable prognostic models: issues in developing models, evaluating assumptions and adequacy, and measuring and reducing errors. *Stat. Med.* **1996**, *15* (4), 361-87.
18. Hand, D.; Till, R., A Simple Generalisation of the Area Under the ROC Curve for Multiple Class Classification Problems. *Machine Learning* **2001**, *45* (2), 171-186.
19. Brier, G., Verification of Forecasts expressed in terms of probability. *Monthly Weather Review* **1950**, *78* (1), 1-3.
20. Efron, B.; Tibshirani, R., Improvements on Cross-Validation: The .632+ Bootstrap Method. *J Am. Stat. Assoc.* **1997**, *92* (438), 548-560.
21. Slominski, A.; Semak, I.; Zjawiony, J.; Wortsman, J.; Li, W.; Szczesniwski, A.; Tuckey, R. C., The cytochrome P450scc system opens an alternate pathway of vitamin D3 metabolism. *The FEBS journal* **2005**, *272* (16), 4080-90.
22. Hevko, J. M.; Murphy, R. C., Electrospray ionization and tandem mass spectrometry of cysteinyl eicosanoids: leukotriene C4 and FOG7. *J. Am. Soc. Mass Spectrom.* **2001**, *12* (7), 763-71.
23. Orendi, K.; Kivity, V.; Sammar, M.; Grimpel, Y.; Gonen, R.; Meiri, H.; Lubzens, E.; Huppertz, B., Placental and trophoblastic in vitro models to study preventive and therapeutic agents for preeclampsia. *Placenta* **2011**, *2011* (32), 023.
24. Gharesi-Fard, B.; Zolghadri, J.; Kamali-Sarvestani, E., Proteome differences of placenta between pre-eclampsia and normal pregnancy. *Placenta* **2010**, *31* (2), 121-5.
25. Ma, K.; Jin, H.; Hu, R.; Xiong, Y.; Zhou, S.; Ting, P.; Cheng, Y.; Yang, Y.; Yang, P.; Li, X., A proteomic analysis of placental trophoblastic cells in preeclampsia-eclampsia. *Cell Biochem. Biophys.* **2014**, *69* (2), 247-58.

26. Leanos-Miranda, A.; Campos-Galicia, I.; Isordia-Salas, I.; Rivera-Leanos, R.; Romero-Arauz, J. F.; Ayala-Mendez, J. A.; Ulloa-Aguirre, A., Changes in circulating concentrations of soluble fms-like tyrosine kinase-1 and placental growth factor measured by automated electrochemiluminescence immunoassays methods are predictors of preeclampsia. *J. Hypertens.* **2012**, *30* (11), 2173-81.
27. Heydarian, M.; McCaffrey, T.; Florea, L.; Yang, Z.; Ross, M. M.; Zhou, W.; Maynard, S. E., Novel Splice Variants of sFlt1 are Upregulated in Preeclampsia. *Placenta* **2009**, *30* (3), 250-255.
28. Gygi, S. P.; Rist, B.; Griffin, T. J.; Eng, J.; Aebersold, R., Proteome analysis of low-abundance proteins using multidimensional chromatography and isotope-coded affinity tags. *J. Proteome Res.* **2002**, *1* (1), 47-54.
29. Jaquemar, D.; Kupriyanov, S.; Wankell, M.; Avis, J.; Benirschke, K.; Baribault, H.; Oshima, R. G., Keratin 8 protection of placental barrier function. *J. Cell Biol.* **2003**, *161* (4), 749-56.
30. Leloup, C.; Magnan, C.; Benani, A.; Bonnet, E.; Alquier, T.; Offer, G.; Carriere, A.; Periquet, A.; Fernandez, Y.; Ktorza, A.; Casteilla, L.; Penicaud, L., Mitochondrial reactive oxygen species are required for hypothalamic glucose sensing. *Diabetes* **2006**, *55* (7), 2084-90.
31. Ahenkorah, J.; Hottor, B.; Byrne, S.; Bosio, P.; Ockleford, C. D., Immunofluorescence confocal laser scanning microscopy and immuno-electron microscopic identification of keratins in human materno-foetal interaction zone. *J. Cell Mol. Med.* **2009**, *13* (4), 735-48.

32. Crockford, D.; Turjman, N.; Allan, C.; Angel, J., Thymosin beta4: structure, function, and biological properties supporting current and future clinical applications. *Ann. N. Y. Acad. Sci.* **2010**, *1194*, 179-89.
33. Moon, E. Y.; Im, Y. S.; Ryu, Y. K.; Kang, J. H., Actin-sequestering protein, thymosin beta-4, is a novel hypoxia responsive regulator. *Clin. Exp. Metastasis* **2010**, *27* (8), 601-9.
34. Young, J. D.; Lawrence, A. J.; MacLean, A. G.; Leung, B. P.; McInnes, I. B.; Canas, B.; Pappin, D. J.; Stevenson, R. D., Thymosin beta 4 sulfoxide is an anti-inflammatory agent generated by monocytes in the presence of glucocorticoids. *Nat. Med.* **1999**, *5* (12), 1424-7.
35. Ulrich, H. D., SUMO teams up with ubiquitin to manage hypoxia. *Cell* **2007**, *131* (3), 446-7.
36. Wennergren, G., Inflammatory mediators in blood and urine. *Paediatr. Respir. Rev.* **2000**, *1* (3), 259-65.
37. Huber, M.; Beutler, B.; Keppler, D., Tumor necrosis factor alpha stimulates leukotriene production in vivo. *Eur. J. Immunol.* **1988**, *18* (12), 2085-8.
38. Zehnder, D.; Evans, K. N.; Kilby, M. D.; Bulmer, J. N.; Innes, B. A.; Stewart, P. M.; Hewison, M., The ontogeny of 25-hydroxyvitamin D(3) 1alpha-hydroxylase expression in human placenta and decidua. *Am. J. Pathol.* **2002**, *161* (1), 105-14.
39. Shin, J. S.; Choi, M. Y.; Longtine, M. S.; Nelson, D. M., Vitamin D effects on pregnancy and the placenta. *Placenta* **2010**, *31* (12), 1027-34.
40. Wengrowski, A. M.; Kuzmiak-Glancy, S.; Jaimes, R., 3rd; Kay, M. W., NADH changes during hypoxia, ischemia, and increased work differ between isolated heart preparations. *Am. J. Physiol. Heart Circ. Physiol.* **2014**, *306* (4), H529-37.

41. Meyburg, J.; Schulze, A.; Kohlmüller, D.; Linderkamp, O.; Mayatepek, E., Postnatal Changes in Neonatal Acylcarnitine Profile. *Pediatr. Res.* **2001**, *49* (1), 125-129.
42. Illsinger, S.; Janzen, N.; Sander, S.; Schmidt, K. H.; Bednarczyk, J.; Mallunat, L.; Bode, J.; Hagebolling, F.; Hoy, L.; Lucke, T.; Hass, R.; Das, A. M., Preeclampsia and HELLP syndrome: impaired mitochondrial function in umbilical endothelial cells. *Reprod. Sci.* **2010**, *17* (3), 219-26.
43. Hatch, G. M.; Choy, P. C., Effect of hypoxia on phosphatidylcholine biosynthesis in the isolated hamster heart. *Biochem. J.* **1990**, *268* (1), 47-54.
44. Choy, P. C.; Chan, M.; Hatch, G.; Man, R. Y., Phosphatidylcholine metabolism in ischemic and hypoxic hearts. *Mol. Cell. Biochem.* **1992**, *116* (1-2), 53-8.
45. Ferrari, R. S.; Andrade, C., Oxidative Stress and Lung Ischemia-Reperfusion Injury. *Oxid. Med. Cell. Longev.* **2015**, *2015*, 14.
46. Robinson, B. S.; Hii, C. S.; Poulos, A.; Ferrante, A., Effect of tumor necrosis factor-alpha on the metabolism of arachidonic acid in human neutrophils. *J. Lipid Res.* **1996**, *37* (6), 1234-45.
47. Jendryczko, A.; Drozd, M., Increased placental phospholipase A2 activities in pre-eclampsia. *Zentralbl. Gynakol.* **1990**, *112* (14), 889-91.
48. Wen, Q.; Liu, L. Y.; Yang, T.; Alev, C.; Wu, S.; Stevenson, D. K.; Sheng, G.; Butte, A. J.; Ling, X. B., Peptidomic Identification of Serum Peptides Diagnosing Preeclampsia. *PLoS One* **2013**, *8* (6), e65571.
49. Brady, J. J.; Judge, E. J.; Levis, R. J., Analysis of amphiphilic lipids and hydrophobic proteins using nonresonant femtosecond laser vaporization with electrospray post-ionization. *J. Am. Soc. Mass Spectrom.* **2011**, *22* (4), 762-72.

50. Eibisch, M.; Zellmer, S.; Gebhardt, R.; Suss, R.; Fuchs, B.; Schiller, J.,  
Phosphatidylcholine dimers can be easily misinterpreted as cardiolipins in complex lipid mixtures: a matrix-assisted laser desorption/ionization time-of-flight mass spectrometric study of lipids from hepatocytes. *Rapid Commun. Mass Spectrom.* **2011**, *25* (18), 2619-26.
51. Anand, S.; Bench Alvarez, T. M.; Johnson, W. E.; Esplin, M. S.; Merrell, K.; Porter, T. F.; Graves, S. W., Serum biomarkers predictive of pre-eclampsia. *Biomark. Med.* **2015**, *9* (6), 563-75.

## **4 Targeted tissue ‘omics’ analysis comparing markers changed in culture in response to proposed mediators of preeclampsia to those markers in actual preeclamptic placenta**

### 4.1 Abstract

Preeclampsia, a common disorder of pregnancy is one of the leading causes of maternal and fetal morbidity and mortality. Globally, it effects 2-10% of pregnancies annually. The placenta is believed to be the central feature in the pathogenesis of this disease. Several abnormalities have been proposed to explain the cause of preeclampsia, the most common ones being placental hypoxia, oxidative stress to placenta and an increase in placental exposure to pro-inflammatory cytokines. As described in Chapter 3, these abnormalities were imposed on healthy placental explants which resulted in significant differential expression of 146 markers in total. Of these, 75 changed with introduction of hypoxia, whereas 23 and 48 were differentially expressed in response to oxidative stress and tumor necrosis factor-alpha. We sought to identify which, if any of these changes were also expressed in actual PE pregnancies. By using ANCOVA and linear regression models as joint criteria for significance, 4 out of 146 biomolecules demonstrated significant differences between preeclamptic placenta and placenta collected from healthy controls. In the initial study (Chapter 3), 2 of these changes were brought about by tumor necrosis factor-alpha (m/z 461.06 (z=+1) and m/z 476.24 (z=+1)), 1 due to hypoxia-reoxygenation (m/z 426.35 (z=+1)) and one with hypoxia (m/z 649.49 (z=+1)). Biomarkers with m/z's 476.24 and 426.35 were identified as a phosphatidylcholine and an acylcarnitine respectively, while the identities of 2 were unknown. Previous research has demonstrated an increase in the abundances of phospholipids as well as acylcarnitines in preeclamptic placenta.

## 4.2 Introduction

Preeclampsia (PE) is a complex disorder of pregnancy characterized by hypertension (>140/90 mmHg) and proteinuria (>300 mg/24 hr).<sup>1</sup> It is the second leading cause of maternal and fetal morbidity following hemorrhage.<sup>2</sup> In severe cases it leads to eclampsia: a condition characterized by grand mal seizures not associated with any previously known abnormal neurologic activity.<sup>3</sup> PE is believed to affect 2-10% of pregnancies worldwide.<sup>3</sup> Each year around ten million women develop PE globally and over 75,000 of these succumb to it.<sup>4</sup> This syndrome is also responsible for the deaths of over 500,000 infants annually.<sup>5</sup> Due to the absence of any diagnostic tests, PE is most commonly diagnosed by observing and confirming symptoms such as high blood pressure and proteinuria. There are no therapeutic remedies to prevent or treat PE.

PE is a condition of abnormal placental function as highlighted by the fact that the symptoms of PE are reversed once the placenta is removed from the body by either vaginal delivery or surgery.<sup>6</sup> In addition PE has been shown to develop in molar pregnancies as well, thus confirming its involvement in the development of this disease.<sup>6</sup>

A number of factors are believed to contribute to the pathogenesis of PE. The most widely accepted ones include placental hypoxia,<sup>7</sup> oxidative stress of the placenta,<sup>8</sup> and/or exposure to increased pro-inflammatory mediators.<sup>9</sup> The aim of our research was to identify which, if any of these hypothesized causative pathways play an important role in the etiology of this unexplained syndrome as identified by unique expression patterns of less abundant peptides, low molecular weight proteins, and potentially other biomolecules. To accomplish this goal two studies were performed. In the first study, healthy human placental explants were cultured under the proposed mediators of PE namely, hypoxia, oxidative stress and exposure to inflammatory cytokines, accompanied by a control group where no provocative agent was introduced and the explants were



cultured in normal conditions of oxygen. These explants were incubated for a total of 48 hrs in their respective environment. They were then processed separately and analyzed by MS. The MS data was analyzed to study differentially expressed molecules between the comparison groups and therefore develop a signature of molecules specific to each abnormality. The second study, reported here, involves peptidomic analysis of those biomolecules demonstrating statistically significant differences between ‘stressed’ and ‘unstressed’ placenta in placental tissue collected from established preeclamptic pregnancies and comparing them with healthy placentas collected and processed identically.

### 4.3 Methods

#### 4.3.1 Tissue collection

The Internal Review Boards of Erlanger Hospital, University of Tennessee, Chattanooga and Brigham Young University approved of these studies. All the specimens were obtained from Erlanger Hospital, University of Tennessee, Chattanooga. Placentas from C-sections and vaginal deliveries were collected, dissected at the intervillous region and flash frozen using liquid nitrogen. In total 26 placental tissues were used in this study, 13 from preeclamptic pregnancies, and 13 from uncomplicated pregnancies. Information regarding gestational age (GA) is provided (Table 4.1) and placentae from pregnancies with pre-existing conditions such as hypertension and diabetes were excluded from the study.

**Table 4.1. Mean and standard deviation of GA for preeclamptic and healthy pregnancies**

<b>PE (n=13)</b>	<b>Controls (n=13)</b>
32.7±5	40.0±1

### 4.3.2 Specimen processing

A block of placental tissue obtained approximately halfway between the cord and the rim. The chorionic plate was dissected away and a ~ 1 cm region of the remaining tissue halfway between chorion interface and the basal plate was obtained. This block representing intervillous tissue was shaved into thin slices using a stainless steel blade and regions with high concentrations of blood vessels and fat deposits were avoided. The tissue slices were further minced and transferred to an autoclaved, sterile beaker. Multiple washes were performed using 1X Phosphate buffered saline (PBS) to remove most of the external blood from the tissue. Washed tissue was then transferred to a stack of autoclaved tissue paper to pat dry them. Following this, 300 mg of dried tissue was then processed, which included tissue homogenization and acetonitrile precipitation. Details of this procedure are described in Chapter 3, but briefly the weighed tissue was homogenized in the presence of 20  $\mu\text{L}$  of protease inhibitor cocktail (P9599, Sigma -Aldrich) and 20  $\mu\text{L}$  of 8.87 mM 1,10-phenanthroline (Sigma -Aldrich). Homogenate was resuspended in 3 mL of 1X PBS, vortexed and centrifuged to remove cell debris. An aliquot of the supernatant was then treated with two volumes of acetonitrile (2:1 v/v). This step is used to deplete high molecular weight (HMW), abundant proteins in order to prevent ion suppression during the MS analysis, thus allowing the interrogation of a much larger set of less abundant species. A known, fixed amount of the protein-depleted sample was then injected into cLC-ESI-MS.

### 4.3.3 Chromatographic separation

An Agilent 1260 Infinity Series HPLC pump system (Agilent Technologies, Karlsruhe, Germany) was part of the LC-MS setup. A volume of 8  $\mu\text{L}$ , containing an apparent protein concentration of 1  $\mu\text{g}/\mu\text{L}$  were injected onto a 1 mm (16.2  $\mu\text{L}$ ) dry-packed MicroBore guard column

(IDEX Health and Science, Oak Harbor, WA), coupled to a 15 cm x 250  $\mu\text{m}$  i.d. capillary column, slurry-packed in-house with POROS R1 reverse-phase medium (Applied Biosystems, Foster City, CA) with a mobile phase flow rate of 5  $\mu\text{L}/\text{min}$ . Mobile phase A was an aqueous solution water/acetonitrile/formic acid (98:2:0.1, v/v/v) and mobile phase B was primarily organic solution containing acetonitrile/water/formic acid (98:2:0.1, v/v/v). Information on the gradient elution has been provided in Chapter 2.

#### 4.3.4 Mass spectrometric analysis

The eluate from the column was introduced into the quadrupole (Q)-time-of-flight (TOF) tandem mass spectrometer (Q-TOFMS) through an electrospray needle to allow in-line analysis (Agilent Technologies 6530 Accurate-Mass Q-TOF/LC/MS). The electrospray needle was set at 3800 V and all the samples were run in the positive ion mode. Mass spectra were obtained over the mass to charge ratio ( $m/z$ ) range of 400–3000, collected in profile mode for each mass spectrum with an acquisition rate of 8 spectra/sec. Data was acquired using MassHunter Data Acquisition B.06.00 and was analyzed using the instrument's Qualitative MassHunter B.06.00 software (Agilent Technologies). Other MS parameters were as follows: gas temperature: 300°C, drying gas flow rate: 5 L/min, nebulizer pressure: 15 psi, fragmentor voltage: 175 V, skimmer voltage: 65 V.

#### 4.3.5 Data analysis

Time normalization, as described previously in Chapter 3, was achieved by defining 2 min windows along the entire LC chromatogram. These reference time markers were used to align elution windows across different runs. The 11 time markers identified for use in these studies of

human placenta are summarized in Results section. In total 146 markers were found to be differentially expressed due to the imposed preeclamptic abnormalities to healthy human placental explants. In order to determine the continued statistical significance of these markers in actual preeclamptic pregnancies, MS data from each of the 11 time windows was exported and the intensities of the 146 targeted individual markers of interest were computed. This analysis was performed by using Agilent's MassHunter Qualitative Analysis B.06.00 software. Following this, statistical tests were performed to evaluate significance of individual markers in this study.

#### 4.3.6 Statistical analysis

Preliminary statistical analysis revealed 8 biomarkers out of 146, continuing to express statistically significant differences between the preeclamptic and control placenta. Most of the placenta from preeclamptic patients were delivered earlier than those from women with normal pregnancies. And because the intensity of the markers may be influenced by GA of the placenta, approaches were taken to account for the effect of GA in searching for statistically significant markers. Thus two more stringent statistical procedures were implemented to negate for the effect of different GA. The first approach uses an analysis of covariance (ANCOVA) model, which compares the average of the measured variables in two different classes (i.e. preeclamptic or control). The covariate in this model is the GA of the each of patients at delivery which is adjusted out of the comparison of the average difference between control and preeclamptic deliveries.

The second approach used simple linear regression to regress the GA on the peak intensities for just the control samples and then to estimate a prediction interval for GAs in the range of the preeclamptic samples. These predicted intervals are then compared with the observed peak

intensities from the preeclamptic samples. If there is no difference in the intensities of these variables between the controls and the preeclamptic deliveries, most of the observed variables should fall within the prediction intervals for deliveries at that GA.

One observation was missing a GA value, so an estimate was obtained using multiple imputation by chained equations based on predictive mean matching.<sup>10</sup>

The two procedures were used because both have particular strengths and weaknesses as analytical tools. The ANCOVA model is good because it directly compares the mean intensities of the peaks between the controls and the preeclamptic placentae while also accounting for the effect of GA. However, there is not much overlap between the GA of the two classes. Consequently, the adjustment for GA relies heavily on those few pregnancies of control and preeclamptic women that have similar GA and the assumption that the pattern seen for deliveries at older GAs can be linearly adjusted to the younger GA. Furthermore, the 2 independent variables, class and GA, are correlated, violating a principal assumption of the model.

The regression model is good in that it directly models the effect of GA, which can be used in detecting effects beyond the GA. These effects are attributed to the class. However, it was necessary to extrapolate to lower GA, requiring that the assumption of a linear relationship between GA and peak intensity be valid. Despite the inherent weaknesses, if the peak intensities for the controls and preeclamptic samples are sufficiently different to be deemed significant by both procedures, we determine that such a marker has a significant relationship with preeclampsia. It should be noted that, even with the precautions we take in accounting for GA, the observed statistical significance may be confounded by GA.

The ANCOVA model used for a specific peak is as follows:  $Y_{ij} = \mu + \gamma X_i + \tau_{ij} + \epsilon_{ij}$ , where  $Y_{ij}$  is the peak intensity for the  $j^{\text{th}}$  placenta in the  $i^{\text{th}}$  class,  $\mu$  is the overall mean,  $\gamma$  is the effect of GA,

$X_{ij}$  is the GA for the  $j^{th}$  placenta in the  $i^{th}$  class,  $\tau_i$  is the effect of GA for the  $i^{th}$  class, and  $\epsilon_{ij}$  is the residual of the  $j^{th}$  placenta in the  $i^{th}$  class. Due to the variability of the peak intensities and the likely presence of outliers, the two largest and smallest peak intensities for both classes for each peak were excluded from this analysis, leaving 9 samples per class. The class effect was calculated based on Type III sums of squares, and any marker with a class effect p-value less than 0.1 was counted as significant.

The regression model used is as follows:  $Y_{il} = \beta_0 + \beta_1 X_{il} + \epsilon_{il}$ , where  $Y_{il}$  is the peak intensity for the  $i^{th}$  individual in the control class,  $\beta_0$  is the intercept,  $\beta_1$  is the estimated coefficient for GA,  $X_{il}$  is the GA for the  $i^{th}$  individual in the control class, and  $\epsilon_{il}$  is the residual for the  $i^{th}$  individual in the control class. If the p-value for  $\beta_1$  was non-significant ( $p > 0.1$ ), a model without the GA effect (i.e. a model including just the intercept) was built, and this reduced model was compared against the model that included the GA effect using an F test; all tests resulted in non-significant p-values, indicating that there was not enough evidence to suggest that, for the given peak, the model including GA as an independent variable was better than the model without any adjustment of GA. Despite the apparent non-significance of GA in many of the models, it was included in some as a conservative measure for adjusting small effects on the measured intensities. Using the selected model, prediction intervals were then estimated spanning the range of all GA. To see if the peak values of the preeclamptic samples followed the same trend of GA as the control samples, the (GA, peak intensity) points were plotted for all preeclamptic samples. Assuming that the preeclamptic samples follow the same pattern as the control samples, it is expected, based on the 95% prediction interval, that 95% of the observed preeclamptic points should be contained within the interval; if significantly fewer than 95% are inside the interval, there's evidence that there is an effect of preeclampsia beyond the GA effect. Probabilities for the number of points

outside the interval based on the binomial distribution were calculated, and markers where the probability was less than 0.1 were counted as significant.

## 4.4 Results

### 4.4.1 Chromatographic time alignment

The 11 time normalization peaks are summarized by their m/z, charge state and approximate elution time as follows: 695.09 (z=+4) 17 min, 827.28 (z=+6) 19 min, 474.2 (z=+1) 21 min, 672.36 (z=+3) 23 min, 686.46 (z=+1) 25 min, 1009.05 (z=+1) 27 min, 616.16 (z=+1) 32 min, 526.28 (z=+1) 34 min, 524.36 (z=+1) 37 min, 650.43 (z=+1) 39 min, 675.53 (z=+1) 41 min.

### 4.4.2 Evaluation of 146 biomarkers that demonstrated differences under PE conditions in PE placenta

Previously, a total of 146 biomarkers were found to be differentially expressed in healthy placental explants maintained under PE conditions (Chapter 3). Of these 75 changed in response to hypoxia; 23 to hypoxia-reoxygenation (an oxidative stress) and 48 in response to TNF $\alpha$  exposure.

On average, placenta collected from actual preeclamptic pregnancies had earlier GAs than those collected from healthy controls. Since there was a correlation between earlier GA and preeclamptic placenta, we undertook measures to account for the potentially confounding effect using 2 statistical models. The ANCOVA model identified 9 significant markers, and the linear regression model identified 32 significant markers. However, only 4 of these markers exhibited significant differences when analyzed by both tests, providing the strongest evidence to suggest



that these markers have significantly different intensities between normal and preeclamptic placenta.

These models found 4 biomarkers with significant differences in abundance between PE placenta and controls. These markers are described in Table 4.2.

**Table 4.2. Biomarker with statistical significant differences between PE placenta and healthy controls.**

<b>m/z</b>	<b>z</b>	<b>Higher in</b>	<b>p-value (ANCOVA)</b>
461.06	+1	TNF $\alpha$	0.0487
476.24	+1	TNF $\alpha$	0.0368
426.35	+1	Hypoxia-reoxygenation	0.0471
649.49	+1	Hypoxia	0.0735

All these 4 biomarkers showed an increased expression in preeclamptic placentae. As can be compared to Chapter 3, 2 of these markers were more abundant in placental explants cultured with TNF $\alpha$ , 1 more abundant in explants cultured under hypoxia and the remaining 1 in explants cultured under conditions producing oxidative stress (hypoxia-reoxygenation). Details of these markers and related information as gathered from the previous study is given in Table 4.3.

**Table 4.3. Statistically significant markers with their identities and average elution time in the total ion chromatogram**

m/z	Z	ID	Elemental composition	Average elution time (min)
461.06	+1	Unknown	Unknown	18.22±0.3 <sup>a</sup>
476.24	+1	Phosphatidylcholine	C <sub>20</sub> H <sub>40</sub> NO <sub>8</sub> NaP	26.47±0.7
426.35	+1	Fatty acyl carnitine O-oleoylcarnitine	C <sub>25</sub> H <sub>48</sub> NO <sub>4</sub>	36.87±0.7
649.49	+1	Unknown	Unknown	40.14±0.1

<sup>a</sup>Standard deviation of elution time.

As can be seen in the table, 2 of the 4 markers have been identified. The biomarker with  $m/z$  426.35 was identified as an acylcarnitine with a fatty acid chain containing 18 carbons and one double bond (C18:1, oleoylcarnitine). Identification of acylcarnitine was based on the production of signature product ion peaks in the MS/MS spectrum of the fragmented precursor. The most common ones are at  $m/z$  60, 85 and 144 (Figure 4.1). Elemental composition was confirmed by performing exact mass studies as well by carrying out a database search based on the MS1 precursor mass (<http://www.lipidmaps.org/>). For the second biomarker ( $m/z$  476.24), a peak at  $m/z$  184.07 was seen which indicated the presence of a phosphocholine headgroup. Exact mass studies accompanied by use of an elemental composition calculator revealed the molecular formula as  $C_{20}H_{40}NO_8NaP$ , which represents a sodiated PC ( $M+Na$  of  $m/z$  454.24). For one of the unknown markers ( $m/z$  461.01), we observed 3 very abundant product ion peaks at  $[M+H-180]$ ,  $[M+H-44]$  and  $[M+H-180-44]$ . Though we saw a pattern of neutral losses as well as very abundant product ions, we were still unable to determine the identity of this markers due to absence of any related information in the database or in the literature.

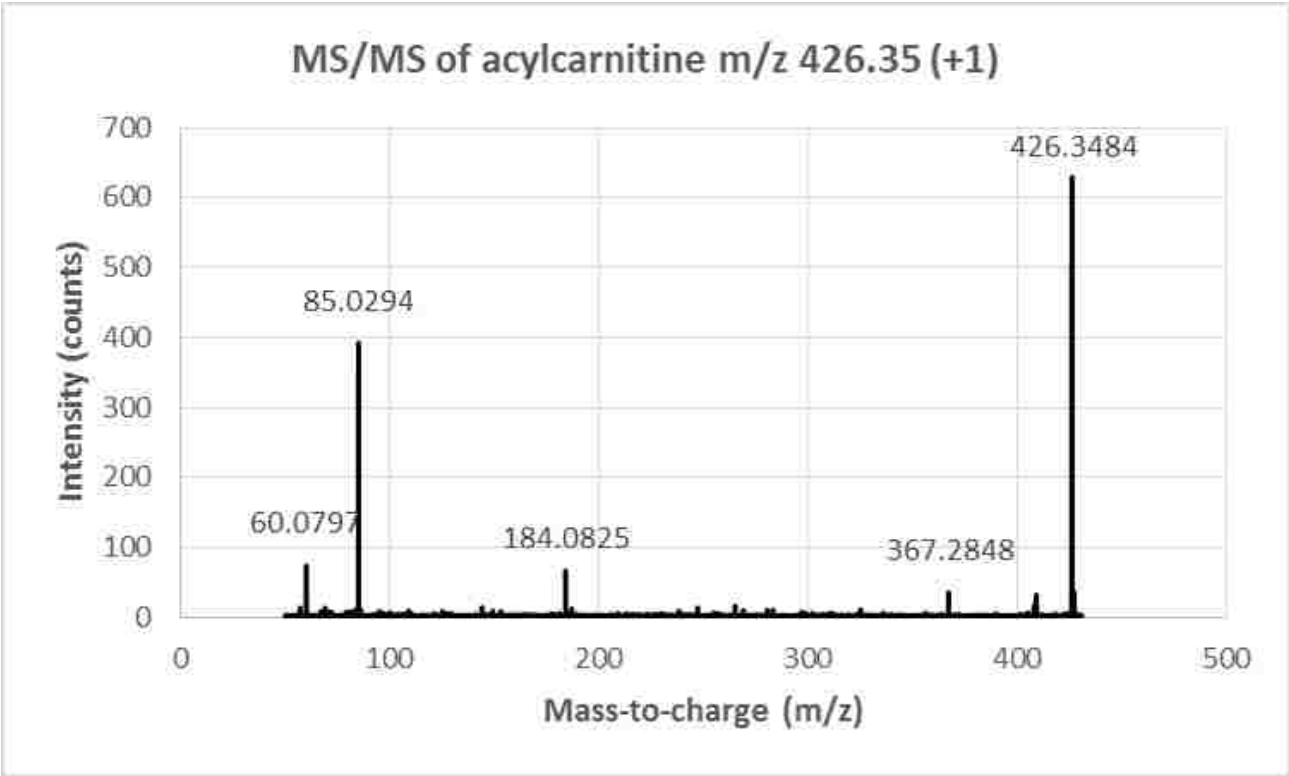

Figure 4.0.1. MS/MS spectra of identified acylcarnitine (m/z 426.35; z=+1)

## 4.5 Discussion

PE still remains a disease with unknown cause. Several mediators have been proposed to be involved in the pathogenesis of this disease.<sup>7-9</sup> Several research groups have performed targeted or untargeted studies to identify features that differ in diseased and healthy placentae. Targeted approaches were performed to monitor a single or a few biomolecules which may play a role in the pathogenesis of PE.<sup>11-13</sup> Untargeted approaches have been most commonly used in terms of performing a more extensive analysis on the placenta from diseased and healthy tissue.<sup>14, 15</sup> Most of the proteomics techniques that have been performed on placental tissue to dissect features of PE have used gel electrophoretic approaches to separate proteins based on their charge and mass, which is followed by mass spectrometry.<sup>16</sup> These approaches, including 2-DGE, are most appropriate for the analysis of abundant HMW proteins.<sup>17</sup> The importance of less abundant, LMW biomolecules has been well described in literature.<sup>18</sup> This fraction of the protein repertoire as well as other LMW metabolites plays important part in the pathophysiology of diseases.

Tissue-proteomics approach developed in our lab allowed us to explore 7000-8000 less abundant LMW species in a single MS run. Of these many species, a previous study conducted by our group observed changes in 146 biomolecules in human placental explants under preeclamptic condition. As the most commonly hypothesized abnormalities in PE are placenta hypoxia, oxidative stress and accumulation of pro-inflammatory cytokines, we investigated which biomolecules showed differential abundances as a consequence of this exposure in healthy placental explants. Details of this work can be found in Chapter 3. Out of the 146 biomarkers,

hypoxia brought changes in 75 of these biomarkers, while 23 were due to effects produced by hypoxia-reoxygenation injury and 48 due to TNF $\alpha$ . The aim of this study was to seek which, if any of these differences are also revealed in actual preeclamptic placentae.

By submitting all these markers to the two statistical models described in methods section we were able to find 4 biomarkers with differential expression in PE placenta when compared to healthy controls common to both analyses. We note that because of the discrepancy in GA between PE and control women, it makes it more difficult to determine whether any difference we found in any marker was due to the pathology of the disease or a gestational age related change. When we looked at the controls, there was no association between gestational age and biomarker abundance for any of these markers, suggesting perhaps that the changes observed were due to disease rather than GA. However, the GA range was limited in the control group. The two individual analyses that corrected for GA found several (9 and 32 respectively) markers that appeared different even after considering the contribution of GA. Nonetheless, those markers that were found statistically different in all analyses, suggested most strongly that they represent real disease related changes.

Two of these markers with m/z 461.06 ( $z=+1$ ,  $p=0.04$ ), 476.24 ( $z=+1$ ,  $p=0.03$ ), had been elevated in placental explants treated with TNF $\alpha$ , one of the markers with m/z 426.35 ( $z=+1$ ,  $p=0.04$ ) was changed with hypoxia/reoxygenation and the marker m/z 649.49 ( $z=+1$ ,  $p=0.07$ ) was changed with hypoxia. The biomarkers with m/z values of 426.35 and 476.24 were identified as an acycarnitine and phosphatidylcholine respectively, while the identities of the remaining 2 were unable to be identified.

Previous research has shown that the composition of PC and PE in human placenta is 45% and 29%-30%, respectively.<sup>19</sup> Several research groups have indicated a higher expression of



phospholipids in PE. It has been believed that endothelial dysfunction, a characteristic of PE, in part is due to an elevated level of lipids in the placenta. This included increases in the decidua basalis of placenta as well as in the placenta proper.<sup>19, 20</sup>

In this study, we observed a higher abundance of PC in particular, for both placental tissue exposed to PE conditions as well as in actual PE placenta. The exact mechanism and the consequences for this change remain unknown, but several theories are proposed to provide an explanation to this increased abundance. One study suggested an activation of the coagulation cascade caused by an increased concentration of phospholipids, as it has been hypothesized that PE like symptoms are developed in the presence of hypercoagulation in the placental circulation.<sup>19</sup> Increased disseminated small clot formation and depleted platelet numbers are common features of PE. In another study by Omatsu et al., a PE like state with hypercoagulation was developed by injecting phosphocholine/phosphoserine macrovesicles into pregnant mice.<sup>21</sup> Another theory suggests a decreased protein expression of ATP-binding cassette (ABC) transporters, in particular ABCA1 in the STB of PE placental tissue. ABCA1 is expressed in placenta and is responsible for phospholipid efflux. A decreased expression of these transporters might be responsible for an accumulation of phospholipids in PE placenta.<sup>22</sup>

Fatty acids are considered to be the major metabolic fuel for placenta and are made available to the mitochondria through a series of steps that begins with the production of acyl-CoA esters.<sup>23</sup> It is in the mitochondria that fatty acid oxidation with production of high energy molecules takes place but the mitochondrial membrane is impermeable to them.<sup>24</sup> Carnitine acts as a shuttle for the fatty acids with transfer from their CoA-esters to form acylcarnitines which enter the inner mitochondria where acyl-CoA esters are formed again and undergo  $\beta$ -oxidation to form acetyl-CoA, NADH and FADH<sub>2</sub>.<sup>24</sup> Acetyl-CoA enters the citric acid cycle to produce additional

NADH and FADH<sub>2</sub> used in the electron transport chain (ETC) to generate ATP. Hypoxia-reoxygenation impairs mitochondrial ETC function,<sup>25</sup> and as a consequence there is an increased accumulation of acylcarnitines as they remain unused.<sup>26</sup> Studies have reported an increase in acylcarnitines in PE.<sup>27,28</sup> Additionally, Thiele *et al* found a 50% increase in carnitine concentration in maternal blood in preeclamptic women. These excess carnitines may also cause tissue damage contributing to PE.<sup>29</sup>

Insufficient spiral artery remodeling has been proposed to be one of the initial events leading to PE, causing a reduced blood flow to the placenta. It has been proposed that this defect in remodeling can cause placental hypoxia<sup>30</sup> or hypoxia accompanied with an accumulation of TNF $\alpha$ ,<sup>31</sup> or an accumulation of TNF $\alpha$  due to placental hypoxia<sup>9</sup> as well as oxidative stress in placenta.<sup>8</sup> This study did not necessarily answer which abnormality, in particular, might be the reason for the physiological changes seen in PE, but it did provide information in terms of which biomolecules demonstrate differential abundance in placental tissue under these conditions as well in actual preeclamptic placentae.

One of the reasons for seeing significant differences only in 4 biomolecules and not more, might be a feature of the timing of pathophysiological stages in PE. The proposed abnormalities initiating PE may well occur early in pregnancy, mostly during the time of placentation, but may not persist through the next several weeks of pregnancy. In the explant culture study that has been described in Chapter 3, PE abnormalities were introduced in full term healthy placental explants, and only for a period of 48 hrs. It is very likely that in fully established PE, markers tied to early changes have already occurred and may then be followed by very different changes. It is also possible that the 48-hr exposure window does not capture the long term sequelae of a much

longer exposure. While it seems less likely, given that these are not full length proteins but actually relatively stable lipids studied here, there may be differences due to the PE and control placenta studied here having been frozen. Also, the mix of both Caesarian and vaginal deliveries in this study may well have increased variability in the data. Finally, it is possible that the actual causes or mediators of active PE are not those proposed by other investigators and are more inferred than real. The 4 markers we did see were distributed across all 3 possible pathologic insults considered here rather than a single pathology.

#### 4.6 Conclusion

To conclude, we have investigated which less abundant, LMW biomolecules are differentially expressed in healthy human placental tissue when exposed to proposed abnormalities of PE, and which of these differentially expressed biomarkers are also different in placentae collected from actual PE pregnancies when compared to healthy controls processed and analyzed identically.

#### 4.7 References

1. Brown, M. A.; Lindheimer, M. D.; de Swiet, M.; Assche, A. V.; Moutquin, J.-M., The Classification and Diagnosis of the Hypertensive Disorders of Pregnancy: Statement from the International Society for the Study of Hypertension in Pregnancy (ISSHP). *Hypertens. Pregnancy* **2001**, *20* (1), ix-xiv.
2. Walsh, C. A.; Baxi, L. V., Mean arterial pressure and prediction of pre-eclampsia. *BMJ : Brit. Med. J.* **2008**, *336* (7653), 1079-1080.
3. Osungbade, K. O.; Ige, O. K., Public health perspectives of preeclampsia in developing countries: implication for health system strengthening. *J. Pregnancy* **2011**, *2011*, 481095.
4. Zhou, C. C.; Irani, R. A.; Dai, Y.; Blackwell, S. C.; Hicks, M. J.; Ramin, S. M.; Kellems, R. E.; Xia, Y., Autoantibody-mediated IL-6-dependent endothelin-1 elevation underlies pathogenesis in a mouse model of preeclampsia. *J. Immunol.* **2011**, *186* (10), 6024-34.
5. English, F. A.; Kenny, L. C.; McCarthy, F. P., Risk factors and effective management of preeclampsia. *Integr. Blood Press. Control* **2015**, *8*, 7-12.
6. Roberts, J. M.; Escudero, C., The placenta in preeclampsia. *Pregnancy Hypertens.* **2012**, *2* (2), 72-83.
7. Soleymanlou, N.; Jurisica, I.; Nevo, O.; Ietta, F.; Zhang, X.; Zamudio, S.; Post, M.; Caniggia, I., Molecular Evidence of Placental Hypoxia in Preeclampsia. *J. Clin. Endocrinol. Metab.* **2005**, *90* (7), 4299-4308.
8. Hung, T.-H.; Burton, G. J., Hypoxia and Reoxygenation: a Possible Mechanism for Placental Oxidative Stress in Preeclampsia. *Taiwan. J. Obstet. Gynecol.* **2006**, *45* (3), 189-200.

9. Conrad, K. P.; Benyo, D. F., Placental cytokines and the pathogenesis of preeclampsia. *Am. J. Reprod. Immunol.* **1997**, *37* (3), 240-9.
10. Buuren, S. v.; Groothuis-Oudshoorn, K., mice: Multivariate Imputation by Chained Equations in R. *Journal of statistical software* **2011**, *45* (3), 67.
11. Gu, Y.; Lewis, D. F.; Wang, Y., Placental Productions and Expressions of Soluble Endoglin, Soluble fms-Like Tyrosine Kinase Receptor-1, and Placental Growth Factor in Normal and Preeclamptic Pregnancies. *J. Clin. Endocrinol. Metab.* **2008**, *93* (1), 260-266.
12. Heydarian, M.; McCaffrey, T.; Florea, L.; Yang, Z.; Ross, M. M.; Zhou, W.; Maynard, S. E., Novel Splice Variants of sFlt1 are Upregulated in Preeclampsia. *Placenta* **2009**, *30* (3), 250-255.
13. Sano, M.; Matsumoto, M.; Terada, H.; Wang, H.; Kurihara, Y.; Wada, N.; Yamamoto, H.; Kira, Y.; Tachibana, D.; Koyama, M., Increased annexin A2 expression in the placenta of women with acute worsening of preeclampsia. *Osaka City Med. J.* **2014**, *60* (2), 87-93.
14. Yang, J. I.; Kong, T. W.; Kim, H. S.; Kim, H. Y., The Proteomic Analysis of Human Placenta with Pre-eclampsia and Normal Pregnancy. *J. Korean Med. Sci.* **2015**, *30* (6), 770-778.
15. Baig, S.; Kothandaraman, N.; Manikandan, J.; Rong, L.; Ee, K. H.; Hill, J.; Lai, C. W.; Tan, W. Y.; Yeoh, F.; Kale, A.; Su, L. L.; Biswas, A.; Vasoo, S.; Choolani, M., Proteomic analysis of human placental syncytiotrophoblast microvesicles in preeclampsia. *Clin. Proteomics* **2014**, *11* (1), 40.
16. Wang, F.; Wang, L.; Xu, Z.; Liang, G., Identification and Analysis of Multi-Protein Complexes in Placenta. *PLoS One* **2013**, *8* (4), e62988.

17. Ma, K.; Jin, H.; Hu, R.; Xiong, Y.; Zhou, S.; Ting, P.; Cheng, Y.; Yang, Y.; Yang, P.; Li, X., A proteomic analysis of placental trophoblastic cells in preeclampsia-eclampsia. *Cell Biochem. Biophys.* **2014**, *69* (2), 247-58.
18. Merrell, K.; Southwick, K.; Graves, S. W.; Esplin, M. S.; Lewis, N. E.; Thulin, C. D., Analysis of low-abundance, low-molecular-weight serum proteins using mass spectrometry. *J. Biomol. Tech.* **2004**, *15* (4), 238-48.
19. Huang, X.; Jain, A.; Baumann, M.; Körner, M.; Surbek, D.; Bütikofer, P.; Albrecht, C., Increased Placental Phospholipid Levels in Pre-Eclamptic Pregnancies. *Int. J. Mol. Sci.* **2013**, *14* (2), 3487-3499.
20. Staff, A. C.; Ranheim, T.; Khoury, J.; Henriksen, T., Increased contents of phospholipids, cholesterol, and lipid peroxides in decidua basalis in women with preeclampsia. *Am. J. Obstet. Gynecol.* **1999**, *180* (3 Pt 1), 587-92.
21. Omatsu, K.; Kobayashi, T.; Murakami, Y.; Suzuki, M.; Ohashi, R.; Sugimura, M.; Kanayama, N., Phosphatidylserine/phosphatidylcholine microvesicles can induce preeclampsia-like changes in pregnant mice. *Semin. Thromb. Hemost.* **2005**, *31* (3), 314-20.
22. Korner, M.; Wenger, F.; Nikitina, L.; Baumann, M.; Surbek, D.; Albrecht, C., PP141. The lipid transporters ABCA1 and ABCG1 are differentially expressed in preeclamptic and IUGR placentas. *Pregnancy Hypertens.* **2012**, *2* (3), 315-6.
23. Shekhawat, P.; Bennett, M. J.; Sadovsky, Y.; Nelson, D. M.; Rakheja, D.; Strauss, A. W., Human placenta metabolizes fatty acids: implications for fetal fatty acid oxidation disorders and maternal liver diseases. *Am. J. Physiol. Endocrinol. Metab.* **2003**, *284* (6), E1098-105.

24. Sharma, S.; Black, S. M., Carnitine homeostasis, mitochondrial function, and cardiovascular disease. *Drug discovery today. Disease mechanisms* **2009**, *6* (1-4), e31-e39.
25. Thu, V. T.; Kim, H.-K.; Long, L. T.; Lee, S.-R.; Hanh, T. M.; Ko, T. H.; Heo, H.-J.; Kim, N.; Kim, S. H.; Ko, K. S.; Rhee, B. D.; Han, J., NecroX-5 prevents hypoxia/reoxygenation injury by inhibiting the mitochondrial calcium uniporter. *Cardiovasc. Res.* **2012**, *94* (2), 342-350.
26. Meyburg, J.; Schulze, A.; Kohlmüller, D.; Linderkamp, O.; Mayatepek, E., Postnatal Changes in Neonatal Acylcarnitine Profile. *Pediatr. Res.* **2001**, *49* (1), 125-129.
27. Illsinger, S.; Janzen, N.; Sander, S.; Schmidt, K. H.; Bednarczyk, J.; Mallunat, L.; Bode, J.; Hagebolling, F.; Hoy, L.; Lucke, T.; Hass, R.; Das, A. M., Preeclampsia and HELLP syndrome: impaired mitochondrial function in umbilical endothelial cells. *Reprod. Sci.* **2010**, *17* (3), 219-26.
28. Oey, N. A.; den Boer, M. E.; Ruiten, J. P.; Wanders, R. J.; Duran, M.; Waterham, H. R.; Boer, K.; van der Post, J. A.; Wijburg, F. A., High activity of fatty acid oxidation enzymes in human placenta: implications for fetal-maternal disease. *J. Inherit. Metab. Dis.* **2003**, *26* (4), 385-92.
29. Thiele, I. G. I.; Niezen-Koning, K. E.; van Gennip, A. H.; Aarnoudse, J. G., Increased Plasma Carnitine Concentrations in Preeclampsia. *Obstet. Gynecol.* **2004**, *103* (5, Part 1), 876-880.
30. Tal, R., The Role of Hypoxia and Hypoxia-Inducible Factor-1Alpha in Preeclampsia Pathogenesis. *Biol. Reprod.* **2012**, *87* (6), 134, 1-8.

31. Benyo, D. F.; Smarason, A.; Redman, C. W.; Sims, C.; Conrad, K. P., Expression of inflammatory cytokines in placentas from women with preeclampsia. *J. Clin. Endocrinol. Metab.* **2001**, *86* (6), 2505-12.



## 5 Concluding remarks

The overall objective of this work was to investigate which of the several hypothesized causal conditions or factors play a role in the etiology of PE as identified by the expression signature of the less abundant, low molecular weight proteins and other biomolecules. Placenta's involvement in the pathogenesis of PE remains unequivocal, which makes it an organ of great interest in the study of PE.

### 5.1 Summary of Current research

#### 5.1.1 Summary: Chapter 2

An approach to study lower molecular weight, lower abundance biomolecules constituents in a tissue was developed in our lab that involved homogenization of tissue followed by acetonitrile precipitation to remove abundant, high molecular weight proteins.<sup>1</sup> Considering the cellular and anatomic complexity of placenta, it was important to test the applicability of this method to study placental features. In an attempt to do so, we investigated regional differences in human placenta as a proof of concept for our approach. Due to the somewhat different cellular composition of the chorionic plate and basal plate of placenta, these two regions have subtle differences in their expressed biomolecules. Such differences should ideally be detectable using our method if we are to apply it to investigating biomolecules in preeclamptic placenta. In our study we found region specific, statistically significant differences in 16 LMW markers between these two sides. Of these, 12 species were identified and/or chemically characterized. Thus, we conclude that our method

will be capable of studying placental features and identifying even subtle differences existing in diseased conditions.

### 5.1.2 Summary: Chapter 3

Once the placental tissue-homogenization approach was developed and optimized to be applied to human placenta, we moved forward to our second study which involved introducing proposed mediators of PE e.g. hypoxia, oxidative stress and an increased concentration of TNF $\alpha$ , a cytokine implicated in PE, to healthy human placental explants collected from elective C-section from uncomplicated pregnancies. This study tested two hypothesis. The first was that there will be significant changes in abundances of some biomolecules as a result of preeclamptic conditions applied to placenta and second that each condition or abnormality will produce a unique set of changes, i.e. a molecular signature. In total, 146 biomolecules had statistically significant changes when combining all three comparison groups, the breakdown being: 75 changes due to hypoxia, 23 due to hypoxia-reoxygenation and 48 due to TNF $\alpha$ . Using tandem MS, 45% of 146 molecules were identified and/or chemically characterized. To develop signatures specific to each stressor, the Lasso statistical model identified 16 markers which were able to well segregate all 4 treatment groups.

### 5.1.3 Summary: Chapter 4

Placentae from preeclamptic (n=13) and healthy (n=13) pregnancies were collected and processed using the same tissue homogenization-ACN precipitation approach. The 146 markers which were differentially expressed in the explant models were studied in frozen preeclamptic and normal

placental tissues and their statistical significance was calculated by comparing with the controls. Using the very strictest statistical criteria, 4 of the 146 biomarkers which showed a differentially increased abundance in the stressed explants in the previous study (Chapter 3) were also elevated in PE placenta. As described in chapter 3, 1 of these changes were due to hypoxic environment, 2 with TNF $\alpha$  and the remaining 1 as a consequence of oxidative stress (hypoxia-reoxygenation). Two of the four differentially expressed species were chemically characterized as a phospholipid (m/z 476.24) and an acylcarnitine (426.35).

## 5.2 Limitations of current research

### 5.2.1 Limitations: Chapter 2

Placenta is an organ known to exhibit a high degree of anatomical compartmentalization. Such variation may affect our results to a significant degree. In my first study where I was investigating regional differences in healthy placentas, I was very cautious to sample tissue from the same location every time a specimen was collected to avoid any kind of variation in sampling. For placental proteomics, generally blood is washed off the tissue, but for our initial experiments we did not remove external blood. Nevertheless, we found differences that were not due to maternal blood being present on the exterior of the tissue. We were still able to analyze and find chorionic plate- or basal plate- specific placental components. Additionally, we studied only two regions of placenta, investigating a third and potentially an important one: the intervillous region would provide more information in terms of cellular composition across the placenta. Also, specimens were collected from a total of 12 placentas which relatively is a small set. A larger set is always preferred if one is to perform an un-targeted ‘omics’ study. Twelve of sixteen significantly different markers

were identified using tandem mass spectrometry, while due to low-abundance of some of them and high charge state of others we were unable to characterize them using CID alone. In such situations other ion activation approaches such as HCD/ETD are more useful, which are not compatible with QTOF MS.

### 5.2.2 Limitations: Chapter 3

In study 2, I used placental explants to introduce proposed abnormalities to simulate PE. The biggest limitation in explant culture there is the need for fresh tissue each time. Processing needs to start shortly after delivery to prevent loss in tissue viability. To overcome this limitation, we collected placenta within 3–5 minutes of delivery and started explant culture within 30 minutes of collection. Another limitation of explant culture is the inefficient transfer of nutrients and oxygen from the culture medium to the tissue. To make sure that this transfer occurs as efficiently as possible, our tissue explants are cut into thin slices. We tried to be as consistent as possible with all other parameters, like weight of the tissue, time required for processing, etc. One of the potential pitfalls of explant culture is the inability for exact simulation of *in vivo* conditions while working *in vitro*. Explant culture, though, simulates the *in vivo* conditions more than isolated cell culture does, because cells in explant culture are in their native environment with cell-to-cell communication preserved. Additionally, stable culture of placental cells involves cells derived from chorionicarcinomas, which may provide a poor reflection of normal or even preelamptic tissue. This makes explant culture the superior option since no model can yet imitate the exact *in vivo* conditions. Additionally, the experiment was designed to incubate placental explant in their respective environment for a period of 48 hours. Though a lot of changes take place in this period of time, PE may actually be a consequence of exposure of provocative agents for an extended period of

time. Conversely, some changes may happen on a much shorter time scale and be lost by 48 hr. In addition, I was able to establish identities of only 45% of the biomarkers which were statistically significant. I believe performing different techniques such as ETD, HCD as available on trap MS instruments will provide complementary information in terms MS/MS data and thus potentially help in identification of markers.

### 5.2.3 Limitations: Chapter 4

As mentioned, placenta exhibits substantial anatomical variations. It is often challenging to obtain meaningful data in such a case. For our third study which involved studying actual preeclamptic placentas, the samples came from Erlanger Hospital, University of Tennessee, Chattanooga. We had instructed them to be as consistent as possible in sample site selection while dissecting tissue from the placentas. Also, the preeclamptic and control placentas were collected from C-sections as well as vaginal deliveries, from women belonging to different races which adds a potential source of variation. Due to PE, some women had to undergo early delivery which resulted in earlier gestational age to PE group as compared to uncomplicated pregnancies. A fraction of these placentas had late term PE. Another major limitation in this study is that the tissue was frozen immediately after its collection and transported on dry ice from Tennessee to BYU. This should minimize changes in the placental proteome. However, the effects of freezing in this way are unknown. The normal placental tissue to be used for comparison was collected at the same site and preserved and shipped in the same fashion as the preeclamptic tissue. Therefore, the effects of time and shipping on sample quality will be nullified, and there should be the same loss of specimen integrity that might occur. In this study we obtained 13 preeclamptic placentae and equal number of controls, which is a relatively small set of samples. In addition, we observed only a

small fraction of the targeted markers that continued to be different. With the most stringent conditions applied, only 4 out of 146 biomarkers responding to PE stressors changed in PE placenta. One reason to explain this effect is that changes in response to proposed PE abnormalities may happen at an early stage in the pregnancy during the events after placentation, and by the time the disease has been progressed to a full blown PE pregnancy, these changes in the expression of signature markers might not continue.

Another source of variation which is inevitable arises due to instrument parameters. LC/MS is sensitive to small, daily changes (for example, temperature). Such changes can create complications while analyzing mass spectral data, thus giving false results. To minimize instrument variation we used internal reference peaks to normalize all our data.

### 5.3 Future objectives

#### 5.3.1 Future research objective: Chapter 3

In study 2 (Chapter 3), in total 146 molecules were significantly different between the stressed explants and controls. 45% of these were identified by performing tandem mass spectrometry. Going forward an attempt can be made to identify the remaining biomolecules by perhaps using different modes of ion activation such as high energy collision induced dissociation (HCD), electron transport dissociation (ETD) and electron capture dissociation (ECD). ETD and ECD are known to aid in identification of peptides with higher charge states as well as keeping intact labile post-translational modifications during the process of fragmentation, thus helping in the identification of modified proteins.

Several mediators other than hypoxia, oxidative stress and an accumulation of cytokines in placenta have been proposed to be involved in the pathogenesis of PE. These factors may act alone or in combination to produce the symptoms of PE. It would be interesting to see the effect of each of these mediators on human placental explants and the changes they bring in the LMW biomolecules. Thus, as a part of ongoing research to study PE, more stressed conditions or provocative agents can be applied or introduced to healthy placental explants. Examples include introduction of sFlt-1, endothelin etc.

### 5.3.2 Future research objectives: Chapter 4

While studying placentae from preeclamptic pregnancies, we only focused on the 146 molecules that were significantly altered as a consequence of abnormal conditions introduced in the healthy placental explants. For a better understanding and a more thorough analysis of PE placenta, a global ‘omics’ study can be done of all the peaks observed in the MS data to find additional biomolecules with significant differences between preeclamptic and normal placenta. Analysis and identification of these species can help throw more light into the mechanism in the fully established PE.

In our first study to identify regional differences in placenta, we concluded that there exist subtle differences in biomolecules between chorionic plate and basal plate. Thus it would be interesting to study chorionic plate and basal plate from preeclamptic placentae and compare them to the two regions from healthy controls. This can provide additional information on the mechanisms and progression of this disease.

In addition to the peptidomics study, for all of the three projects, a global lipidomic approach can be performed too, to study multiple classes of lipids using positive ion mode as well

as negative ion mode of ionization. A liquid-liquid extraction approach can be used such as Bligh-Dyer extraction to extract polar as well as non-polar lipids. These can then be injected in MS directly or subjected to a pre-fractionation step using a suitable chromatography column. Either approach will be useful in defining the altered lipidome in preeclamptic conditions as well in preeclamptic placenta.



#### 5.4 References

1. Alvarez, M. T.; Shah, D. J.; Thulin, C. D.; Graves, S. W., Tissue proteomics of the low-molecular weight proteome using an integrated cLC-ESI-QTOFMS approach. *Proteomics* **2013**, *13* (9), 1400-11.