

Full Length Research Paper

Relevance of modeling and simulation in the management of engineering projects

Rowland Jerry Ekeocha* and Stephen Kalu Ogbonnaya

Department of Mechanical Engineering, College of Engineering, Covenant University, Ota Nigeria.

Received 23 January, 2018; Accepted 28 March, 2018

Project management is one of the most important and poorly understood areas of management. Delays and cost overruns are common in projects such as construction, power generation, defense, software, product development, etc. Project management is affected by problems relating to costing and scheduling. Changes in the design of customer creates costly ripple effects which in turn lead to delay and disruption throughout an entire organization. In most cases, errors made earlier in engineering projects are discovered close to the end which may require costly rework, expediting, overtime, hiring, schedule slippage or reductions in project scope or quality. Poor profitability, loss of market share and reputation, increased turnover of management and workforce, lower productivity and higher costs are some of the effects of such errors. Other consequences include divisive and costly litigation between customers and contractors over responsibility for overruns and delays. This paper describes in brief, the relevance of modeling and simulation in the management of engineering projects with a case study in the oil and gas industry.

Key words: Engineering management, modeling, project management, simulation applications, facility management.

INTRODUCTION

Model

The model of a system is a replica (physical or mathematical) which has all the properties (attributes) and function of the system. According to Singh (2009), formal models can be classified as physical, mathematical and computer models. The physical model is the scaled down model of the actual system which has all its properties. Mathematical models represent a system with mathematical equations, while computer models utilize computers to numerically evaluate mathematical equations.

Models can be formal or mental. Mental models have some powerful advantages. The mental model is flexible and takes wide range of information into account, which in turn can be processed and presented in a variety of forms. In addition, mental models can be adapted to new situations and modified as new information becomes available according to Sterman (1992). The disadvantages of mental models include inexplicability, ambiguity and contradiction of its assumptions which are yet to be resolved.

The limitations of mental models are addressed by

*Corresponding author. E-mail: ekeochaj@yahoo.com

formal models. Formal models are explicit with unambiguous assumptions. They interrelate many factors simultaneously and can be simulated under controlled conditions which enable analysts to conduct non feasible experiment in real system. In addition, formal models can reasonably compute logical consequences of the assumptions of a modeler (Sterman, 1992).

These advantages notwithstanding, formal models can be misused as a tool which robs on their superiority over mental models. However, formal models possess attributes of quality and validity for easy assessment as compared to mental models (Sterman, 1992).

Project

A project is a temporary group of activities designed to produce a unique product, service or result, according to the Guide to the Project Management Body of Knowledge (PMBOK, 2013). A project is temporary in that, it has a defined beginning and end in time, and therefore has defined scope and resources. A project is unique in that, it is not a routine operation, but a specific set of operations designed to accomplish a singular goal. A project team therefore includes people who do not necessarily work together but sometimes come from different organizations and across multiple disciplines.

Project management

Project management can be referred to as the application of knowledge, skills and techniques to execute projects effectively and efficiently. According to Sterman (1992), project types pass through five stages of lifecycle.

Project conception and initiation

During this phase, a decision making team is constituted to identify the benefits of the project to the organization as well as its actualization.

Project definition and planning

A project plan, project charter and/or project scope may be put in writing, outlining the work to be performed. During this phase, a team should prioritize the project, calculate a budget and schedule, and determine the resources that are needed.

Project launch or execution

This is a good time to bring up important project related information while responsibilities are assigned to

members of the project team.

Project performance and control

During this phase, project managers can adjust schedules and do the needful to keep the project on track. Project status and progress in the actual plan are compared by project managers, as resources to perform the scheduled work are made available

Project close

Project close involves the evaluation of the project showing project success at the completion of all tasks with the approval of the project sponsor.

Projects and project management processes vary from industry to industry; however, there are traditional elements of a project. The overriding goal is typically to offer a product, change a process or solve a problem in order to benefit the organization. The Guide to PMBOK (2013) classifies the project management processes into nine knowledge areas which bring the processes together by their commonality, namely: management of project integration, scope, time, cost, quality, human resource, communication, risk and procurement.

Project management has a misconception of assuming scheduling as the only major activity in a project. Scheduling is certainly important in project management but not to the detriment of developing a shared understanding of what the project is supposed to accomplish or constructing a good work breakdown structure (WBS) to identify all the work to be done. Projects fail because project sponsor demand that the project manager must finish the job by a certain time, within budget, and at a given magnitude or scope, while achieving specific performance levels. This means that the four major constraints: cost, performance, time and scope (CPTS), of a project are controlled by the sponsor leaving out the contractor in the scheme of things. The relationship between the CPTS constraints can be written as follows:

$$C = f(P, T, S)$$

In words, this means, "cost is a function of performance, time and scope". Graphically, it is presented as a triangle, in which C, P and T are the sides and S is the area. This is shown in Figure 1.

Figure 2 shows that two more constraints- resources and risk- have been included to align with the standard published in the PMBOK® Guide. It should be noted that quality is equivalent to performance. Working within these 5 constraints is a constant challenge of project management:



Figure 1. Standard project management constraints. Source: Project Management Body of Knowledge (PMBOK® Guide, 2013).



Figure 2. Project Management Constraints Source: Project Management Body of Knowledge (PMBOK® Guide, 2013).

1. If the schedule slips and the scope of the project cannot change, then costs are adjusted.
2. If the schedule slips and costs are held constant, the quality or performance of the deliverable will be at risk.
3. If risks are not fully acknowledged and understood, the successful completion of the project will be threatened.

4. If the project lacks available resources, the schedule will be compromised.
5. If the scope is undefined and changes are not managed, the project cost and schedule cannot be established and planned.

With these constraints in place within a predefined system, changing one condition will necessarily affect the others. However, if one or more of the primary constraints of scope, schedule or cost are not restricted, managing the project would likely not present many challenges or problems because any problem could be resolved simply by making changes to the unrestricted constraints (Juran and Godfrey, 2009).

The Standish Group (www.standishgroup.com) discovered that original targets of cost, performance, time and scope (CPTS) were achieved in about 17% of software projects carried out in the United States. It was further revealed that 50% of the targets were changed for reasons of lateness or cost overruns while the remaining 33% were cancelled outright. This means that 83% of software projects were unsuccessful. Thus in a year, when companies in U.S. spent more than \$250 billion on software development nationwide, about \$208 billion was lost on changed targets and completely canceled projects. Product development is not left out. It also suffers similar dismal rates of failure, waste and cancellation experienced in software projects. In product development, about 30% of the resources are channeled to rework. Inadequate project planning and application of inappropriate tools are some of the causes of such failures. These dismal failures notwithstanding, the deployment of modeling and simulation tools has introduced great improvement in the management of projects generally and engineering projects in particular in terms of cost and time (Mizell and Linda, 2007).

Simulation and models in engineering project management

Ferens and Christensen (1998) posit that cost and schedule estimation for large engineering development projects is historically inaccurate. Popular estimating models have been shown to be only within 25% of actual costs for 50% of the time. Simulation models can be used to communicate the uncertainty and complexity of the development process and can provide a check on other estimating methods that may be used. The ability to obtain an accurate estimate of an entire project prior to its start is unfortunately unrealistic. However, as management commits resources to fund such projects or bid for a job, cost and schedule estimates become paramount. Simulation models are usually deployed to analyze the effects of process changes, and not necessarily for developing initial cost and schedule estimations. According to Cooper (1980), modeling and

simulations are widely used in project management, including large scale projects in shipbuilding, oil and gas production, defense, aerospace, construction and power plants. Sterman (1992) asserts that models are used to manage projects more effectively to assess the magnitude and sources of cost and schedule overrun in the context of litigation. In addition to project management, system models are widely used in business strategy and policy assessment.

METHODOLOGY

The relevance of simulation and modeling in the management of engineering project is demonstrated by a case study of the cold vent compression executed on Agbami Floating, Production, Storage and Offloading (FPSO) vessel of Chevron Nigeria Limited.

Case study

The Cold Vent Compression Project executed on Agbami FPSO vessel is one of the many projects where different simulation and modeling tools are deployed at different phases of the project to ensure they are completed safely, within budget and schedule such that the new system can be integrated into existing system for smooth operation. The project was conceived to tie a cold vent system (a system designed to collate Hydro Carbon, HC gas reliefs from atmospheric oil storage (Cargo) tanks and exit the gas to the atmosphere without burning it) to a vapour recovery unit system which had spare capacity. The main objective of the project was to eliminate the venting of hydrocarbon gas to the atmosphere which portended potential fire and explosion if the gas comes in contact with a source of ignition. Another objective was to minimize the incessant loss of production as a result of the shutdown of the facility each time the gas detectors pick up the gas molecules.

Prior to initiation of this engineering project, a multi-functional team was assembled and a proprietary risk management model called Chevron Risk Matrix similar to the one developed by Chinbat (2009) was used to perform hazard analysis of the installation. This model enabled the team to evaluate the risk the facility was exposed to by considering the consequences and likelihood of occurrence of initiating events. Based on the risk ranking, the team recommended that the project should be initiated. An excerpt of the Risk Matrix Model is shown in Figure 3.

At the front end and detailed engineering stages of the project, one of the process engineering and simulation model utilized was the "Hysis". This is a global simulation tool used to model and simulate the new facility with the existing facility. This simulation helped the team to establish the optimum operating conditions of the new facility in relation to the current operating conditions. In addition, this helped to establish that the tie-in will not lead to process upsets and consequently a disruption in the business. The process flow diagram resulting from the modeling and simulation is shown in the Figure 4.

In addition to the above tool, another process modeling and simulation tool known as pipe phase was utilized to establish the right sizes of pipes to be used based on pressure drop and erosional velocity criteria. A snapshot of the model is shown in Figure 5.

DISCUSSION

An alternative to the two process, engineering modeling

and simulation tools is to perform rigorous hand calculations and depend on multiple assumptions based on the engineer's experience. This approach can adversely affect the project schedule and introduce risks that can threaten the operationability and functionality of the facility after installations.

Another modeling tool that was deployed to capture, sequence, manage and track the multiple activities was the Primavera. The model enabled the team to see the entire scope of the project at a glance and identify the critical path. The result of this deployment was the development of several mitigation plans to ensure the project schedule and consequently cost were within published numbers.

Deployment of the various modeling and simulation tools enabled the team to complete and commission the project within schedule unlike the duration of other projects of similar complexity. This project saved the company millions of dollars and the project team members were duly recognized for their outstanding performance and use of value improving practices which include modeling and simulation tools.

The deployment of modeling and simulation in the case study corroborates Sterman (1992) assertion that models are used to manage projects more effectively to assess the magnitude and sources of cost and schedule overrun. Furthermore, modeling and simulation tools in project management can lead to the compression of time and space of a project (Ping and Simaan, 2009).

Conclusion

The application of modeling and simulation tools cuts across various industries globally, like manufacturing, transportation, oil and gas, accounting, medical, trading, academic and the like. Several new modeling and simulations tools are developed everyday while existing ones are improved regularly. Hence, modeling and simulations tools will continue to be of great relevance to engineering projects at various stages.

Modeling and simulations are widely used in project management where the tools are deployed to manage engineering projects. Simulation models are effectively deployed to assess the magnitude and sources of cost and schedule overrun in the context of litigation. In addition to project management, system models are widely used in business strategy and policy assessment.

In the case study, the deployment of various modeling and simulation tools led to completion of the project within schedule and with no cost overruns. In fact, appreciable savings were recorded in terms of cost and project duration that attracted commendation for the project team.

Clearly, the utilization of modeling and simulation tools in project management can lead to the compression of time and space of a project. Modeling and simulation are

Likelihood Description & Index (with confirmed safeguards)			Legend Legend applies to identified HES risks. (see guidance documents for additional explanations) 1, 2, 3, 4 - short-term, interim risk reduction required. Long term risk reduction must be developed and implemented. 5 - Additional long term risk reduction required. If no further action can be reasonably taken, SBU management approval must be sought to continue the activity. 6 - Risk is tolerable if reasonable safeguards / management systems are confirmed to be in place and consistent with relevant requirements of the Risk Mitigation Closure Guidelines. 7, 8, 9, 10 - Manage risk. No further risk reduction required. Risk reduction management / team discretion.						
Likelihood Descriptions	Likelihood Indices								
Consequence can reasonably be expected to occur in life of facility	1	Likely	6	5	4	3	2	1	
Conditions may allow the event to occur at the facility during its lifetime, or the event has occurred within the Business Unit	2	Occasional	7	6	5	4	3	2	
Exceptional conditions may allow consequences to occur within the facility lifetime, or has occurred within the OPCO	3	Seldom	8	7	6	5	4	3	
Reasonable to expect that the event will not occur at this facility. Has occurred several times in the industry, but not in the OPCO	4	Unlikely	9	8	7	6	5	4	
Has occurred once or twice within industry	5	Remote	10	9	8	7	6	5	
Rare or unheard of	6	Rare	10	10	9	8	7	6	
Consequence Descriptions & Index (without safeguards)	Consequence Indices		Decreasing Consequence/Impact						
			6	5	4	3	2	1	
			Incidental	Minor	Moderate	Major	Severe	Catastrophic	
	Consequence Description	Safety	Workforce: Minor injury such as a first-aid. AND Public: No impact	Workforce: One or more injuries, not severe. OR Public: One or more minor injuries such as a first-aid.	Workforce: One or more severe injuries including permanently disabling injuries. OR Public: One or more injuries, not severe.	Workforce: (1-4) Fatalities OR Public: One or more severe injuries including permanently disabling injuries.	Workforce: Multiple fatalities (5-50) OR Public: multiple fatalities (1-10)	Workforce: Multiple fatalities (>50) OR Public: multiple fatalities (>10)	
		Health (Adverse effects resulting from chronic chemical or physical exposures or exposure to biological agents)	Workforce: Minor illness or effect with limited or no impacts on ability to function and treatment is very limited or not necessary AND Public: No impact	Workforce: Mild to moderate illness or effect with some treatment and/or functional impairment but is medically manageable OR Public: Illness or adverse effect with limited or no impacts on ability to function and medical treatment is limited or not necessary.	Workforce: Serious illness or severe adverse health effect requiring a high level of medical treatment or management OR Public: Illness or adverse effects with mild to moderate functional impairment requiring medical treatment.	Workforce (1-4): Serious illness or chronic exposure resulting in fatality or significant life shortening effects OR Public: Serious illness or severe adverse health effect requiring a high level of medical treatment or management.	Workforce (5-50): Serious illness or chronic exposure resulting in fatality or significant life shortening effects. OR Public (1-10): Serious illness or chronic exposure resulting in fatality or significant life shortening effects.	Workforce (>50): Serious illness or chronic exposure resulting in fatality or significant life shortening effects. OR Public (>10): Serious illness or chronic exposure resulting in fatality or significant life shortening effects.	
		Environment	Impacts such as localized or short term effects on habitat, species or environmental media.	Impacts such as localized, long term degradation of sensitive habitat or widespread, short-term impacts to habitat, species or environmental media	Impacts such as localized but irreversible habitat loss or widespread, long-term effects on habitat, species or environmental media	Impacts such as significant, widespread and persistent changes in habitat, species or environmental media (e.g. widespread habitat degradation) .	Impacts such as persistent reduction in ecosystem function on a landscape scale or significant disruption of a sensitive species.	Loss of a significant portion of a valued species or loss of effective ecosystem function on a landscape scale.	
	<p>The above legend applies only to HES risks, where risk levels 1-6 are actionable and mandatory. For risks that may result in facility damage, business interruption, loss of product, the 'Asset' category below should be used. Asset risk is at the discretion of management. Under no circumstances may a direct or indirect translation of Asset loss to HES consequences, or between any discrete categories of HES consequences be inferred.</p>								
	Consequence Descriptions & Index (without safeguards)	Consequence Indices		6	5	4	3	2	1
				Incidental	Minor	Moderate	Major	Severe	Catastrophic
	Consequence Description	Assets (Facility Damage, Business Interruption, Loss of Product)	Minimal damage, negligible downtime or asset loss. Costs < \$100,000.	Some asset loss, damage and/or downtime. Costs \$100,000 to \$1 Million.	Serious asset loss, damage to facility and/or downtime. Costs of \$1-10 Million.	Major asset loss, damage to facility and/or downtime. Cost > \$10 Million but < \$100 Million.	Severe asset loss or damage to facility. Significant downtime, with appreciable economic impact. Cost > \$100M but < \$1 Billion.	Total destruction or damage. Potential for permanent loss of production. Costs > \$1 Billion.	
<p>This matrix is endorsed for use across the Company. It is not a substitute for, and does not override any relevant legal obligations. Under no circumstances should any part of this matrix be changed or modified, adapted or customized. This matrix identifies health, safety, environmental and asset risks and is to be used only by qualified and competent personnel. Where applicable it is to be used within the Riskman2 structure and governance of an OE Risk Management Process. If applied outside of these Processes, it is also mandatory to manage identified intolerable risks and comply with the Risk Mitigation Closure Guidelines.</p>									

Figure 3. An excerpt from Chevron Risk Matrix Model.
Source: Chevron Nigeria Limited.

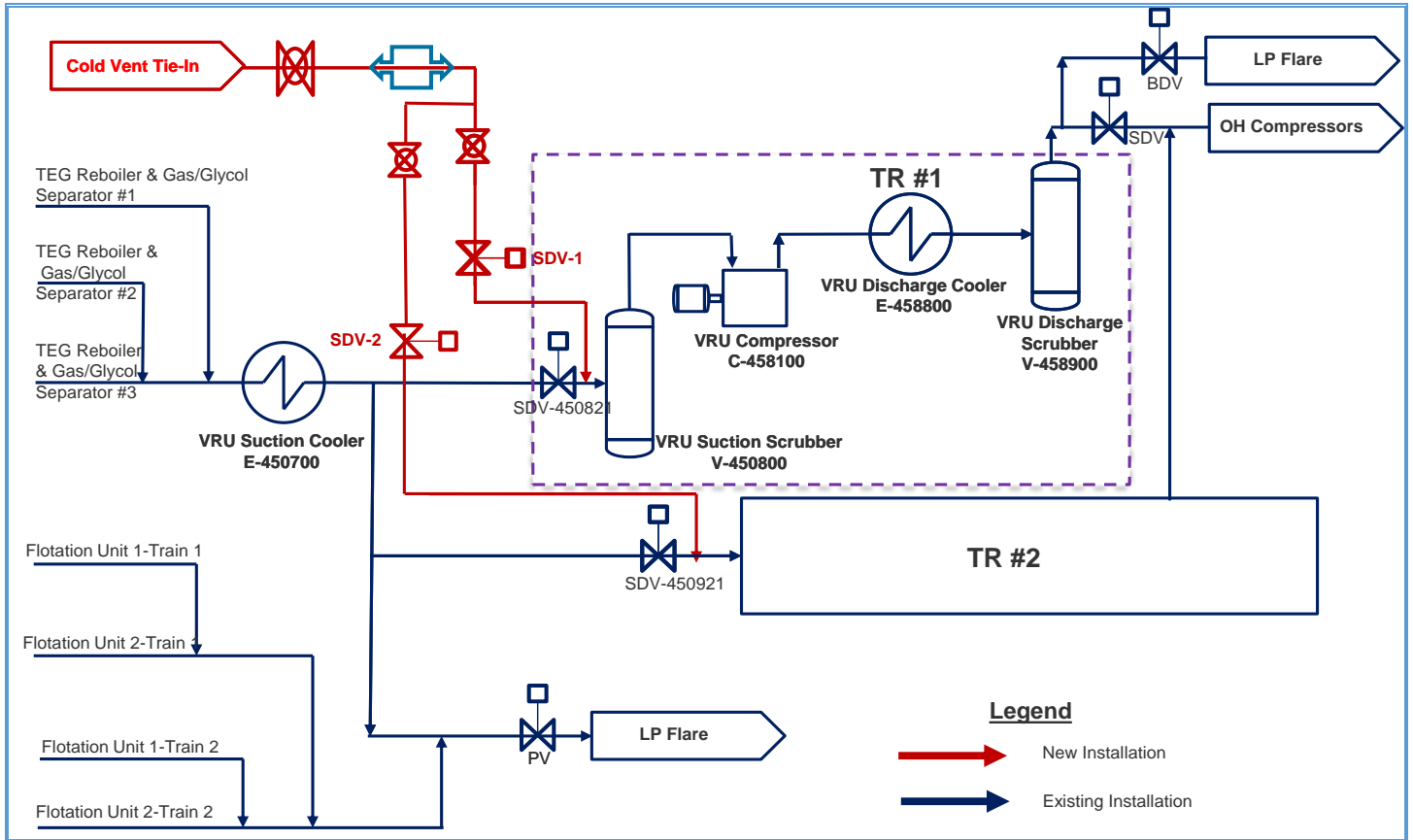

Figure 4. Cold vent compression project process flow diagram. Source: Chevron Nigeria Limited.

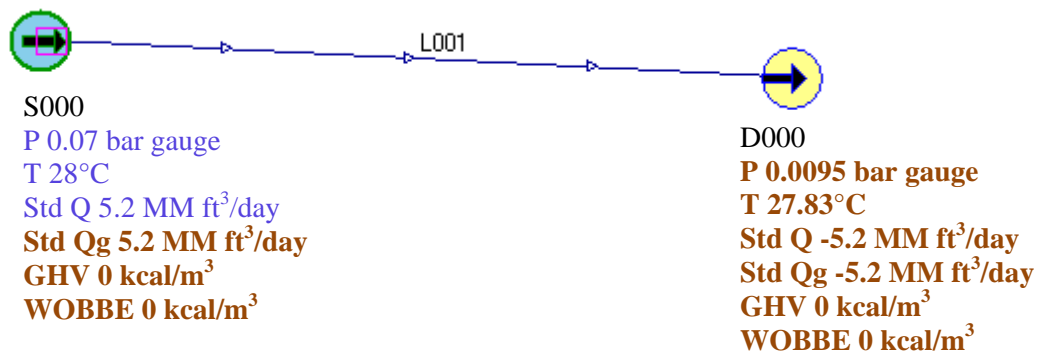

Figure 5. Pipe phase model of the cold vent compression project. Source: Chevron Nigeria Limited.

indeed very relevant in the management of engineering projects.

CONFLICT OF INTERESTS

The authors have not declared any conflict of interests.

REFERENCES

Chinbat U (2009). Using Simulation for Reducing Risk of a Mining Optimization Project. Int. J. Simul. Model. (IJSIMM) 8(3):166-177.
 Cooper K (1980). Naval Ship Procurement: A Claim Settled and a Framework Built, Interfaces. Cambridge, MA: Production Press. 10(6):20-36.
 Ferens DV, Christensen DS (1998). Calibrating Software Cost Models to Department of Defense Databases - A Review of Ten Studies.

- ISPA/SCEA Joint. International Conference Proceedings. Toronto, Canada, Air Force Institute of Technology.
- Guide to the Project Management Body of Knowledge (PMBOK® Guide, 2013)—Fifth Edition.
- Juran JM, Godfrey AB (2009). Quality Handbook – Fifth Edition.
- Mizell C, Linda M (2007). A Project Management Approach to Using Simulation for Cost Estimation on Large, Complex Software Development Projects). NASA EA-C, Kennedy Space Center, FL 32899.
- Ping W, Simaan MA (2009). Large-scale Simulation Modeling System for Industrial Construction. Can. J. Civil Eng. 36(9):1517-1529.
- Singh VP (2009). System Modeling and Simulations. New Age International Publishers.
- Sterman JD (1992). System Dynamics Modeling for Project Management. System Dynamics Group, Sloan School of Management, Massachusetts Institute of Technology, Cambridge MA 02139.