



BSCCH- 201

B. Sc. II YEAR INORGANIC CHEMISTRY-II

1	H																	2	He																
3	Li	4	Be																	10	Ne														
11	Na	12	Mg																	18	Ar														
19	K	20	Ca	21	Sc	22	Ti	23	V	24	Cr	25	Mn	26	Fe	27	Co	28	Ni	29	Cu	30	Zn	31	Ga	32	Ge	33	As	34	Se	35	Br	36	Kr
37	Rb	38	Sr	39	Y	40	Zr	41	Nb	42	Mo	43	Tc	44	Ru	45	Rh	46	Pd	47	Ag	48	Cd	49	In	50	Sn	51	Sb	52	Te	53	I	54	Xe
55	Cs	56	Ba	72	Hf	73	Ta	74	W	75	Re	76	Os	77	Ir	78	Pt	79	Au	80	Hg	81	Tl	82	Pb	83	Bi	84	Po	85	At	86	Rn		
87	Fr	88	Ra	104	Rf	105	Db	106	Sg	107	Bh	108	Hs	109	Mt	110	Ds	111	Rg	112	Cn	113	Nh	114	Fl	115	Mc	116	Lv	117	Ts	118	Og		
57	La	58	Ce	59	Pr	60	Nd	61	Pm	62	Sm	63	Eu	64	Gd	65	Tb	66	Dy	67	Ho	68	Er	69	Tm	70	Yb	71	Lu						
89	Ac	90	Th	91	Pa	92	U	93	Np	94	Pu	95	Am	96	Cm	97	Bk	98	Cf	99	Es	100	Fm	101	Md	102	No	103	Lr						

**SCHOOL OF SCIENCES
DEPARTMENT OF CHEMISTRY
UTTARAKHAND OPEN UNIVERSITY**

BSCCH-201

INORGANIC CHEMISTRY-II



**SCHOOL OF SCIENCES
DEPARTMENT OF CHEMISTRY
UTTARAKHAND OPEN UNIVERSITY**

Phone No. 05946-261122, 261123

Toll free No. 18001804025

Fax No. 05946-264232, E. mail info@uou.ac.in

<http://uou.ac.in>

Board of Studies

Prof. Govind Singh

Director, School of Sciences
Uttarakhand Open University

Prof S. P. S. Mehta

Professor Chemistry
Department of Chemistry
DSB Campus, Kumaun University
Nainital

Dr. Charu C. Pant

Programme Coordinator
Department of Chemistry
School of Sciences,
Uttarakhand Open University
Haldwani, Nainital

Prof. B. S. Saraswat

Professor Chemistry
Department of Chemistry
School of Sciences, IGNOU, New Delhi

Prof. D. S. Rawat

Professor Chemistry
Department of Chemistry
Delhi University, Delhi

Programme Coordinators

Dr. Charu C. Pant

Department of Chemistry
School of Sciences,
Uttarakhand Open University
Haldwani, Nainital

Dr. Shalini Singh

(Assistant Professor)
Department of Chemistry
School of Sciences,
Uttarakhand Open University
Haldwani, Nainital

Unit Written By

Unit No.

1. Dr. K. S. Dhami (Ret. Proff.)

Department of Chemistry
D.S.B. Campus, Kumaun University
Nainital

01, 02, 03, 04 & 05**2. Dr. Geeta Tiwari**

Department of Chemistry
D.S.B. Campus, Kumaun University
Nainital

06, 07, 08 & 09

Course Editor

Prof. B.S. Saraswat

Professor of Chemistry (Retd.)
School of Sciences,
Indira Gandhi National Open University (IGNOU),
Maidan Garhi, New Delhi - 110068

Title	:	Inorganic Chemistry II
ISBN No.	:	
Copyright	:	Uttarakhand Open University
Edition	:	2018

Published by : **Uttarakhand Open University, Haldwani, Nainital- 263139**

CONTENTS

BLOCK- 1 d- BLOCK ELEMENTS

Unit-1 Chemistry of elements of first transition series	1-24
Unit-2 Chemistry of element of second transition series	25-45
Unit-3 Chemistry of element of third transition series	46-66

BLOCK-2 f- BLOCK ELEMENTS

Unit-4 Chemistry of Lanthanide elements	67-82
Unit-5 Chemistry of Actinides elements	83-95

BLOCK-3 CO-ORDINATION CHEMISTRY AND REDOX REACTIONS

Unit-6 Co-ordination Compounds	97-124
Unit-7 Isomerism of Co-ordination Compounds	125-165
Unit-8 Oxidation and Reduction	166-192

BLOCK- 4 CONCEPTS OF ACIDS AND BASES

Unit-9 Acids and Bases	193-218
------------------------	---------

UNIT 1: CHEMISTRY OF THE ELEMENTS OF FIRST TRANSITION (3-d) SERIES

CONTENTS:

- 1.1 Objectives
- 1.2 Introduction
- 1.3 Characteristic Properties of d-Block Elements
- 1.4 Properties of the Elements of the First Transition series
- 1.5 Binary Compounds and Complexes
- 1.6 Relative Stability of their Oxidation States
- 1.7 Coordination number and Geometry
- 1.8 Summary
- 1.9 Terminal Questions
- 1.10 Answers

1.1 OBJECTIVES

The objective of writing the text material of this unit is to acquaint the readers to the characteristic properties of the d-block elements, in general, such as their general electronic configuration and variable oxidation states, complex formation tendency, magnetic properties, formation of coloured ions/compounds, catalytic activity, etc. and periodic properties, *viz.*, atomic radii, atomic volume, ionic radii, melting and boiling points, ionization energies and reactivity, standard electrode potentials and reducing properties, etc. along with their periodic variation along the series. It is also aimed at throwing light on the above properties of the first transition series, in particular, to illustrate the relative stability of the oxidation states of these elements along with to discuss the coordination number and geometry of their complexes and the binary compounds of these elements.

1.2 INTRODUCTION

The d-block elements have been defined as “the elements whose atoms receive the last electron in the d-subshell belonging to the penultimate or (n-1)th shell”. The d-block elements are also called the transition elements or metals. This is because they exhibit gradual transitional behaviour between highly reactive s-block

(electropositive) and p-block (electronegative) elements, i.e. their properties have been found to be intermediate between those of the s-block and p-block elements. Thus these elements are located in the middle of the periodic table and are the members of the Groups 3 to 12 (IIIB to VIII to II B) in the modern periodic table. According to IUPAC definition, “a transition element is an element which has an incomplete d-subshell in either neutral atom or in ions in chemically significant (or common) oxidation state”. According to this definition zinc (Zn), cadmium (Cd) and mercury (Hg) are excluded from the list of transition elements as they neither have partly filled d-subshell in their atoms or ions nor they show the usual properties of transition elements to an appreciable extent. Still in order to rationalize the classification of elements, they are studied along with other d-block elements.

There are four series of elements which constitute the *d*-block elements. Each series comprises ten elements as given below:

1. Elements of the First Transition series or 3d-Transition series: The elements from scandium (Sc, $Z = 21$) to Zinc (Zn, $Z = 30$) form the 3d-series.

2. Elements of the Second Transition series or 4d-Transition series: This series consists of the elements from yttrium (Y, $Z = 39$) to cadmium (Cd, $Z = 48$).

3. Elements of the Third Transition series or 5d-Transition series: The elements lanthanum (La, $Z = 57$) and hafnium (Hf, $Z = 72$) to mercury (Hg, $Z = 80$) constitute the 5d-Transition series.

4. Elements of the Fourth Transition series or 6d-Transition series: The elements actinium (Ac, $Z = 89$) and rutherfordium (Rf, $Z = 104$) to copernicium (Cn, $Z = 112$) are the members of this series. All these elements are radioactive and do not occur in nature. These have been artificially made in the laboratory.

1.3 CHARACTERISTIC PROPERTIES OF D-BLOCK ELEMENTS

Some of the important characteristics of the d-block elements are summarized as follows:

1.3.1 Electronic Configuration and Variable Oxidation States

The d-block elements have a valence shell electronic configuration of $(n-1)d^{1-10}ns^{0-2}$ where $(n-1)$ stands for inner shell whose d-orbitals may have one to ten electrons and the s-orbitals of the outermost shell (n) may have no electron or one or two electrons. The filling of d-orbitals takes place after the s-orbital of next higher shell has already filled as has been discussed in Aufbau principle in Unit 1 (BCH-101). This is because ns orbitals have lower energy than $(n-1)d$ orbitals. But during ionization of the elements (oxidation), the electrons are first lost from ns level followed by the expulsion from $(n-1)d$ subshell (deviation from the expected behaviour) because $(n-1)d$ subshell becomes of the lower energy than ns subshell once the filling of electrons commences in $(n-1)d$ subshell.

Most of the d-block elements show several oxidation states (variable) in their compounds due to the availability of d-electrons in the valence shell which comprises of the two subshells, *viz.*, $(n-1)d$ and ns whose orbitals are quite close together in energy and hence the electrons can be used from both the subshells for bonding and under different conditions different number of electrons can be used by them. The variability in the oxidation states increases towards the middle of the series from both ends, i.e. left \rightarrow middle \leftarrow right. It has been observed that the d-block elements can form ionic bonds in their lower oxidation states and the ionic character of the bond decreases as well as the covalent character increases with increasing oxidation state. As a result, with decreasing ionic character the acidic character of the oxides and chlorides increases.

1.3.2 Complex Formation Tendency:

The cations of d-block elements are unique in their tendency to form complexes with several molecules such as ammonia, water, etc. or different ions such as cyanide, NO_2^- , halide ions, etc. These molecules or ions are called ligands. The complex forming tendency of these elements is attributed to the following factors:

- (a) Small size and high positive charge density,
- (b) Availability of vacant d-orbitals of right energy to accept the lone pairs of electrons from the approaching ligands,
- (c) Exhibition of variable oxidation states.

The detailed account of this tendency will be given in the respective sections mentioned ahead.

1.3.3 Magnetic Properties:

Many compounds of d-block elements exhibit magnetic properties. Qualitatively speaking, there are several kinds of magnetism. The substances which are weakly repelled by the strong magnetic field are termed as **diamagnetic** while those which are weakly attracted by the strong magnetic field are called **paramagnetic**. These substances lose their magnetism on removing the magnetic field. Diamagnetism is the property of the completely filled electronic subshells and is shown by all substances to more or less extent. Paramagnetism is produced by the presence of unpaired electrons and because most of the d-block metal atoms and ions have unpaired electrons, they are paramagnetic in behaviour.

In some transition metals (e.g. Fe, Co, Ni) unpaired electron spins are more pronounced and show much more paramagnetism than the other d-block metals. Such metals are called **ferromagnetic** metals and magnetic property shown by them is known as ferromagnetism. Such metals can be permanently magnetized. The detailed account will be given in the section 1.4 of this unit and in subsequent units.

1.3.4 Formation of Coloured Ions/ Compounds:

The majority of compounds of d-block elements, whether ionic or covalent, are coloured in solid or solution state. This property of d-block elements is in marked difference from those of s or p-block elements which are white or light coloured.

The colour of a substance arises from the property of the substance to absorb light of certain wavelength in the region of visible light (white light) when the latter interacts with the substance. The colour of the substance is the colour of the transmitted light component and is complementary to the colour of light component absorbed. The colour of d-block metal ions is associated with

- (a) an incomplete d-subshell in the metal ion,
- (b) the nature of surrounding groups around the metal ion.

The whole act of exhibition of colour by d-block ions/compounds can be explained as follows. In a free gaseous or isolated ion the five d-orbitals are degenerate, i.e. of same energy. Since five d-orbitals are oriented differently in space, the surrounding groups affect the energy of some orbitals more than others in the compounds. This destroys their degeneracy. For example, in the simplest case of an octahedral complex, they form two groups of orbitals of different energy:

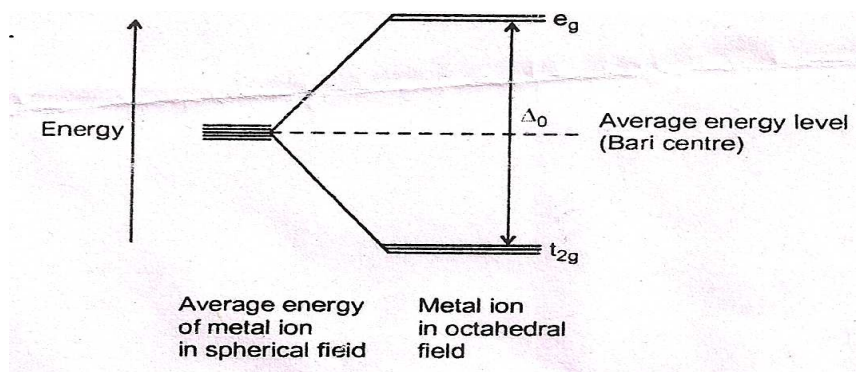

Fig. 1.1 Bary centre

Thus, in d-block metal ions with partially filled d-subshell, it is possible to promote electron(s) from one set of d-orbitals to another set (group) of higher energy by fairly small energy absorbed from the visible light. The colour of the compounds depends on the energy difference (gap) between the two groups (sets) of d-orbitals. This in turn depends on the nature of ligands and their arrangement around the metal ion in the compound / complex.

1.3.5 Catalytic Activity:

The catalytic activity of d-block elements and their compounds is associated with their variable oxidation states and their capability of forming interstitial compounds. A number of d-block metals and their compounds are known to catalyse various reactions of industrial importance, e.g., vanadium (V) oxide in the manufacture of sulphuric acid by contact process, etc. An important view of the mechanism of catalysis is that at solid surface of the catalyst, bonds would be formed between the molecules of the reactants and atoms of the catalysts thereby increasing the concentration of the reactants at the surface. This weakens the bonds of the reactant molecules due to lowering of the activation energy.

1.3.6 Formation of Interstitial and Non-stoichiometric Compounds:

The d-block elements form interstitial compounds with small non-metal atoms such as H, C, N, B, Si, etc. due to the ability of metal lattice to accommodate these non-metal atoms between the metal atoms without distortion of structure.

One of the striking properties of these metals is the formation of non-stoichiometric compounds which often exhibit semiconductivity, fluorescence and behave as heterogeneous catalysts. This non-stoichiometry is due to the defects in the solid structures.

1.3.7 Metallic Character and Alloy Formation:

All the d-block elements are metals, good conductors of heat and electricity, are malleable and ductile. All are solids except Hg (mercury) which exists as liquid at ordinary temperature.

These metals form alloys with each other due to almost similar sizes of the atoms. Thus the atoms of one metal can easily take up positions in the crystal lattice of the other. The alloys are usually harder and have higher melting points than the parent metals, are more resistant to corrosion than their constituents.

1.3.8 Periodic Properties and Their Variation along the Series:

The atomic radii, atomic volumes, ionic radii, melting and boiling points, ionization energies and reactivity, standard electrode potential and reducing properties, etc. are the important periodic properties of the d-block elements which vary and have a definite trend, in general, along each series. These will be discussed below:

a) Atomic Radii, Atomic Volumes and Ionic Radii.

The atomic radii generally decrease, with a few exceptions, on moving from left to right in each series of the transition elements due to increased nuclear charge at each step and constant value of the azimuthal quantum number (i.e. 1) receiving the last electron.

The d-block elements have low atomic volumes as compared to those of the neighbouring s- and p-block elements. This is due to the fact that in these elements

(n-1) d-subshells are being filled and the increased nuclear charge pulls the electron cloud inwards.

The ionic radii of the d-block elements follow the same trend as the atomic radii, i.e. the radii of the ions having the same charge decrease with increasing atomic number. These properties will be discussed in detail for every series.

b) Melting and Boiling Points

The melting and boiling points of these elements are generally very high showing that they are held by strong forces. The melting and boiling points have the highest values in the middle of the series because, perhaps these elements have the maximum number of unpaired d-electrons available for bonding, detailed account of which will be given ahead for every series.

c) Ionization Energies and Reactivity

The ionization energy values of the d-block elements are fairly high and lie in between those of s- and p-block elements, i.e. these elements are less electropositive than s-block elements and more so than p-block elements. Hence, these elements do not form ionic compounds as readily as s-block elements and form covalent compounds as well. Because of the existence of covalent bonding, they have high heats of sublimation, i.e. a large amount of energy is required to convert them from solid to vapour state. The metal ions also do not get hydrated easily. Due to these parameters, the metal ions have a small tendency to react. Examples will be given in each series.

d) Standard Electrode Potentials and Reducing Properties

The standard reduction potential values of transition elements are generally lower (negative) than that of the standard hydrogen electrode (taken as zero). Thus they evolve H_2 gas from acids though most of them do that at low rate.

These metals are poor reducing agents which are contrary to the expected behaviour because of the high heats of vaporisation, high ionization energies and low heats of hydration. Example, if available will be given in each series.

1.4 PROPERTIES OF THE ELEMENTS OF FIRST TRANSITION SERIES

As has already been mentioned in the beginning that the first transition series is also known as 3d-series because the last or the differentiating electron in the atoms of these elements enters the 3d-subshell. This series starts at scandium, the element of Group 3 and ends at zinc, the element of Group 12, containing a total of ten elements. Thus, this series of elements lies in between calcium (Ca, Z=20) and gallium (Ga, Z=31), the elements of Group 2 and Group 13. The ten elements of the first transition series are scandium (Sc, Z=21), titanium (Ti, Z=22), vanadium (V, Z=23), chromium (Cr, Z=24), manganese (Mn, Z=25), iron (Fe, Z= 26), cobalt (Co, Z= 27), nickel (Ni, Z=28), copper (Cu, Z= 29) and zinc (Zn, Z= 30). These elements are much more important than those of second transition series. All the characteristics properties of the d-block elements are shown by the elements of first transition series which are given below:

1.4.1 Electronic Configuration and Variable Oxidation States.

The general valence shell electronic configuration of these elements is $3d^x4s^y$ where $x=1$ to 10 and $y= 1$ or 2, i.e. the 3-d subshell has one to ten electrons from Sc to Zn and 4s-subshell, in general, has two electrons (i.e. $4s^2$) except in Cr and Cu which have only one 4s electron (i.e. $4s^1$). The exceptional valence shell configuration of Cr and Cu is attributed to the exchange energy effect and the extra stability of the resulting half-filled and completely-filled subshells. "The shifting of an electron from one subshell to another of similar or slightly higher energy in order to achieve the half-filled or completely-filled subshell is known as **exchange energy effect**". The state of affairs can be shown as follows:

Cr (Z= 24): $3d^44s^2$ (expected but unstable) \longrightarrow $3d^54s^1$ (actual, more stable).

Cu (Z=29): $3d^94s^2$ (expected but unstable) \longrightarrow $3d^{10}4s^1$ (actual, more stable).

As is evident, there is exchange of electrons from 4s to 3d subshell thereby increasing the stability of the valence shell configuration in Cr and Cu atoms. Thus, among 3d-series elements, only Cr and Cu exhibit irregular/anomalous electronic configurations.

The first transition series elements generally show variable (many) oxidation states in their compounds / ionic forms. The cause of showing different oxidation states is that these elements have several 3d electrons which are quite close to 4s – electrons in energy. The minimum oxidation state shown by all the elements of this series is +2 except Cr and Cu which show +1 oxidation state as well. The number of oxidation states shown increases from Sc to Mn and then decreases till Zn which shows the +2 oxidation state only. As a result, among these elements, Cr and Mn show the maximum number of oxidation states from +1 to +6 and +2 to +7, respectively. From Sc to Mn, the highest oxidation state shown by any element is equal to the group number but the latter elements do not follow this trend. This is evident from the following table:

Elements:	Sc	Ti	V	Cr	Mn	Fe	Co	Ni	Cu	Zn
Group number	3	4	5	6	7	8	9	10	11	12
Lowest oxidation state	+2	+2	+2	+1	+2	+2	+2	+2	+1	+2
Highest oxidation state	+3	+4	+5	+6	+7	+6	+4	+3	+2	+2

It has been observed that the lower (+2, +3, etc.) oxidation states generally dominate the chemistry of the first transition series. For an element the relative stability of various oxidation states can be explained on the basis of the stability of d^0 , d^5 and d^{10} configurations, e.g. Ti^{4+} ion ($3d^0 4s^0$) is more stable than Ti^{3+} ($3d^1 4s^0$) because of the presence of $3d^0$ subshell. Similarly, Mn^{2+} ($3d^5 4d^0$) ion is more stable than Mn^{3+} ($3d^4 4s^0$) ion since Mn^{2+} ion has $3d^5$ subshell.

It has also been observed that first transition series elements form ionic oxides and chlorides in the lower oxidation states which are basic in nature. As the oxidation state of the elements increases, covalent character and acidic nature of these compounds also increases, e.g., MnO (+2) is basic, Mn_2O_3 (+3) and MnO_2 (+4) are amphoteric and Mn_2O_7 (+7) is acidic. Similarly, CrO (+2) is basic, Cr_2O_3 (+3) is amphoteric and CrO_3 (+6) is acidic. Also VCl_2 (+2) is basic and $VOCl_3$ (+5) is acidic.

1.4.2 Complex Formation Tendency:

The elements of first transition series fulfill all conditions of complex formation and are, thus, most suitable for this purpose. As a result, the cations of these elements have a strong tendency to form complexes with certain molecules (e.g. CO, NO, NH₃, etc.) or several ions (e.g. F⁻, Cl⁻, CN⁻ etc.). These molecules and ions are called ligands (L) and have one or more lone pairs of electrons on their donor atom (usually central atom) which they donate to the metal ion/atom (M) during the process of complex formation via M←L coordinate covalent bonds. This happens because the metal ions are electron deficient in most of their oxidation states or even the atoms are electron acceptors. Small size and high charge density of the metal ions facilitate the formation of the complexes which also depends on the basicity of the ligands. The complex formation tendency increases as the positive oxidation state of the metal ion increases.

The nature of the complexes depends on the orbitals available on the metal ion / atom for bonding. These orbitals are s, p and d type. The structures commonly found in the complexes of the elements of first transition series are linear, square planar, tetrahedral and octahedral. This shows that the metal orbitals are hybridized before bonding with the ligand orbitals, e.g. [Ni(CN)₄]²⁻ ion is square planar while [NiCl₄]²⁻ ion is tetrahedral (detail of the complexes have been given ahead in this section).

1.4.3 Magnetic Behaviour:

As has been mentioned earlier, there are several kinds of magnetism observed in the ions /compounds or complexes of transition metals. Among the transition metal compounds paramagnetism is common though some metals in the elemental form also show ferromagnetism.

Origin of Paramagnetism

The electrons being charged particles act as tiny magnets (or micro magnets) by themselves and determine the magnetic properties of the substances in two ways:

- (a) Spin motion or spinning of the electron on its axis produces spin magnetic moment and

(b) Orbital motion or the movement of the electron round the nucleus produces orbital magnetic moment.

The resultant of the above two moments gives the total moment produced by an electron. The observed magnetic moment of the compounds is the sum of the moments of all the electrons present in them. If the two electrons with opposite spins are paired in the same orbital, the magnetic moment produced by one electron is cancelled by that caused by the other electron because both the electrons will have equal but opposite moment thereby giving zero resultant magnetic moment. Such substances which have paired electrons will not show paramagnetism, rather they are diamagnetic.

But if there are unpaired electrons in the ions/atoms of the substance it has the moment produced by all the unpaired electrons. The resultant or total moment in them is sufficiently high to overcome the magnetic moment induced by an approaching magnetic field. Hence, such substances instead of experiencing repulsion, are attracted in a magnetic field and are called paramagnetic substances.

The magnetic moments of atoms, ions and molecules are expressed in units called **Bohr Magnetron** (B.M.) which is defined in terms of the fundamental constants as

$$1 \text{ B.M.} = \frac{eh}{4\pi mc}$$

where h = Planck's constant, e = electronic charge, c = velocity of light and m = mass of electron.

The magnetic moment of a single electron is given by the expression

$$\mu_s \text{ (B.M.)} = g\sqrt{S(S+1)} \text{ (According to wave mechanics)}$$

Where S = resultant spin quantum number and g = gyromagnetic ratio (called g -factor). The quantity $\sqrt{S(S+1)}$ is the value of the spin angular momentum of the electron and thus g is the ratio of magnetic moment to the angular momentum. For a free electron, g value is nearly 2 (i.e. 2.00023).

In transition metal compounds/complexes, the unpaired electrons are present in the outer shell of metal ions and in such cases the spin component is much more

significant than the orbital contribution because the orbital motion of these electrons is said to be quenched or suppressed. Therefore, the latter can be neglected in comparison to the former. In such cases, the total magnetic moment is, therefore, considered entirely due to the spin of the unpaired electrons and μ_s is given by

$$\mu_s = 2\sqrt{S(S+1)} = \sqrt{4S(S+1)} \text{ BM (By putting the value of } g = 2)$$

Now $S = n \times s$ where n = number of unpaired electrons and s = spin quantum number (irrespective of its sign)

$$S = n \times \frac{1}{2} = \frac{n}{2}$$

Putting this value of S in the above expression

$$\mu_s = \sqrt{4 \frac{n}{2} \left(\frac{n}{2} + 1\right)} = \sqrt{2n \left(\frac{n+2}{2}\right)} \text{ B.M.}$$

$$\text{Or } \mu_s = \sqrt{n(n+2)} \text{ B.M.}$$

μ_s is also expressed as μ_{eff} , i.e. effective magnetic moment which is dependent only on the number of unpaired electrons and their spins. Hence, this formula of magnetic moment is also called **spin only formula**.

Thus, the permanent magnetic moment of 3d-transition elements gives important information about the number of unpaired electrons present in them and it varies with n . The calculated magnetic moments corresponding to 1, 2, 3, 4 and 5 unpaired electrons will be (using above formula) $\sqrt{3} = 1.73$ B.M., $\sqrt{8} = 2.83$ B.M., $\sqrt{15} = 3.87$ B.M., $\sqrt{24} = 4.90$ B.M. and $\sqrt{35} = 5.92$ B.M., respectively.

The number of unpaired electrons evaluated from the magnetic moment value for a compound/complex gives the valuable information regarding the type of orbitals that are occupied as well as those available for hybridisation and also the structure of the molecules or complexes provided we have the idea of strength of the ligands (spectrochemical series). For example, here we discuss the structure of $[\text{MnBr}_4]^{2-}$ complex ion in which Mn is in +2 oxidation state and its coordination number is 4.

Mn atom (Z=25): [Ar] 3d⁵4s² 4p⁰

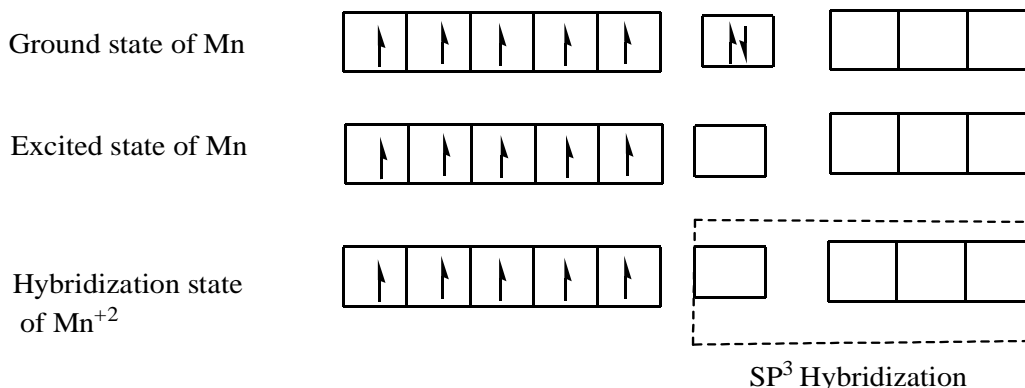

In the complex ion, Mn²⁺ ion is linked with four Br⁻ ions as ligands which exert weak ligand field on the metal ion orbitals. As a result the five unpaired d-orbitals remain unaffected and one s and 3p empty orbitals of metal ion (only four hybrid orbitals are required) hybridise before bond formation producing sp³ hybrid orbitals thus giving tetrahedral structure to the complex ion. The calculated magnetic moment of this complex is nearly 5.92 B.M. which indicates the presence of five unpaired electrons. If that is the situation, the tetrahedral structure of the complex ion is confirmed involving only s and p orbitals.

Similarly for the complexes with coordination number 6, i.e. six ligands are attached to the central metal ion, we can predict whether the complex is outer or inner orbital complex from the knowledge of weak and strong ligands, e.g. [Co(H₂O)₆]²⁺ is an outer orbital complex and [Co(NH₃)₆]²⁺ is an inner orbital complex having the central metal ion, Co²⁺ involving sp³d² and d²sp³ hybridisation, respectively.

1.4.4 Formation of Coloured Ions/Compounds

The cause of the exhibition of colour by the ions/compounds/complexes of the d-block elements has been discussed earlier. The elements of first transition series form coloured ions/compounds/complexes due to the presence of unpaired electrons in them. For example, [Co(H₂O)₆]²⁺ is pink, Cu⁺ (d¹⁰) ion and its salts are colourless but Cu²⁺ (d⁹) ion and its compounds are coloured, CuSO₄.5H₂O is blue which actually is represented as [Cu(H₂O)₄]₂SO₄.H₂O and [Cu(NH₃)₄]²⁺ is dark blue (almost violet). Similarly, [Ni(NO₂)₆]⁴⁻ is red and [Ni(NH₃)₆]²⁺ is blue. Among the other compounds VO₂⁺ is pale yellow, CrO₄²⁻ is strongly yellow, MnO₄⁻ is purple in colour, and [Ti(H₂O)₆]³⁺ is green coloured.

The colour of the complex ion depends on the nature of the ligands and type of complex formed. The metal ions with completely empty or completely filled d-subshell (as well as their compounds) are colourless, viz., Sc^{3+} ($3d^0$), Ti^{4+} ($3d^0$), Cu^+ ($3d^{10}$), Zn^{2+} ($3d^{10}$) etc.

1.4.5 Catalytic Activity

Elements of the first transition (3d) series and their compounds have been used in many industrial processes. Their availability in a variety of oxidation states makes them capable of forming intermediate products with various reactants and their tendency to form interstitial compounds which can absorb and activate the reacting species facilitate their application as catalyst. For example, finely divided Ni is used as a catalyst in hydrogenation reactions; MnO_2 catalyses the decomposition of H_2O_2 ; TiCl_4 is used as a catalyst for polymerisation of ethene in the manufacture of polythene; V_2O_5 is employed in the catalytic oxidation of SO_2 to SO_3 in the contact process of manufacture of H_2SO_4 ; Fe is used in the manufacture of NH_3 by Haber's process; Cu acts as a catalyst in the manufacture of $(\text{CH}_3)_2\text{SiCl}_2$ during the synthesis of silicones. Cu/V is used in the large scale production of Nylon-66. Fe(III) ions catalyse the reaction between iodide and peroxodisulphate ions.

1.4.6 Formation of Interstitial and Non-stoichiometric Compounds

Elements of the 3d-transition series are capable of forming interstitial compounds, e.g., Ti_2C , V_2C , ScN , TiN , Fe_4N etc. These compounds have the properties of alloys being hard and good conductors etc.

These elements also form non-stoichiometric compounds. For example, titanium forms TiO_x ($x=0.65 - 1.25$ and $1.998 - 2.000$); vanadium forms VO_x ($x= 0.79 - 1.29$); manganese forms Mn_xO ($x= 0.848 - 1.00$); iron form Fe_xO ($x = 0.833 - 0.957$), etc. These compounds have variable composition and are formed due to the variability of oxidation states and solid defects. Sometimes the interstitial and non-stoichiometric compounds are the same.

1.4.7 Metallic Character and Alloy Formation

The metals of first transition series are hard, malleable and ductile. These exhibit face centered cubic (fcc), body centered cubic (bcc) or hexagonal close packed (hcp) type

of lattice structures. These metals are good conductors of heat and electricity. Copper and metals of the iron triad are softer than other metals.

The common alloys of these metals are as follows: brass (Cu-Zn), nichrome (Ni-Cr), monel metal (Cu-Ni), german silver (Cu-Ni-Zn), stainless steel (Fe-Cr-Ni-Mn), alnico steel (Fe-Ni-Co-Al), etc. These alloys are harder and have higher melting points than the parent metals. They are also more resistant to corrosion than their constituents.

1.4.8 Periodic Properties and Their Variation along the Series

The melting and boiling points, atomic and ionic radii, atomic volumes, ionization energies and standard electrode potentials along with reducing properties are the main periodic properties of these metals along the series from Sc to Zn, which are discussed below:

a) Atomic Radii, Atomic Volumes and Ionic Radii

As has been discussed earlier for d-block elements, the atomic radii of the elements of first transition series follow the same trend as is applied for other d-block elements. The values generally decrease along the series up to Ni then increase slightly for Cu but pronouncely for Zn. Thus Zn has exceptional value only lower than those for the first two elements and higher than those of others. This is evident from the following table:

Metal atoms	Sc	Ti	V	Cr	Mn	Fe	Co	Ni	Cu	Zn
Atomic radii: (pm)	144	132	122	118	117	117	116	115	117	125

This happens due to the increased attraction between the outer electrons and increasing nuclear charge along the period. The close values of the atomic radii from Cr to Cu are due to the existence of increased screening effect of 3d-electrons which are added in each step and which shield the 4s-electrons from the inward pull though the nuclear charge increases continuously in the series from one element to the other. The screening effect in Zn ($3d^{10}$) is maximum and hence has exceptional value.

The atomic volumes of these elements as given below are comparatively low because of the filling of 3d-orbitals instead of 4s which is the subshell of the last shell. This causes increased nuclear pull acting on the outer electrons. The densities of these elements are very high. Atomic volumes decrease up to Cu and increase thereafter for Zn.

Metal atoms	Sc	Ti	V	Cr	Mn	Fe	Co	Ni	Cu	Zn
Atomic volume:(cm ³)	15.0	11.0	8.3	7.2	7.3	7.1	6.7	6.6	7.1	9.2

The ionic radii of these elements follow the same trend as the atomic radii, i.e. the radii of the ions with the same charge generally go on decreasing as we move across the series except only for the last element. Radii of the bivalent and trivalent ions of the elements of this series are listed below:

Bivalent ions	Sc ²⁺	Ti ²⁺	V ²⁺	Cr ²⁺	Mn ²⁺	Fe ²⁺	Co ²⁺	Ni ²⁺	Cu ²⁺	Zn ²⁺
Ionic radii (pm)	95	90	88	84	80	76	74	72	72	74
Trivalent ions	Sc ³⁺	Ti ³⁺	V ³⁺	Cr ³⁺	Mn ³⁺	Fe ³⁺	Co ³⁺	Ni ³⁺	--	--
Ionic radii (pm)	81	76	74	69	66	64	63	62	--	--

b) Melting and Boiling Points

The melting and boiling points of these elements are generally high and have irregular trend in the values as given below:

Elements	Sc	Ti	V	Cr	Mn	Fe	Co	Ni	Cu	Zn
Melting point ⁰ C	1540	1670	1900	1875	1245	1535	1495	1453	1083	420

As is evident from this table, the highest melting point is for V (1900 ⁰C) and Zn, the last element has exceptionally low melting point (420 ⁰C). Among other elements

Mn and Cu have lower melting points as compared to other members. The boiling points are very high, $>2200^{\circ}\text{C}$ except for Zn (906°C) as expected.

c) Ionization Energies and Reactivity

The first ionization energy values of 3d-series elements show irregular trend as shown below:

Elements:	Sc	Ti	V	Cr	Mn	Fe	Co	Ni	Cu	Zn
I.E. (KJ):	631	658	650	653	717	759	758	737	746	906

But the second and third I.E. values generally show the increasing trend from Sc to Zn. The appreciably higher value of first I.E. for Zn is attributed to the additional stability associated with completely filled 3d-subshell ($3d^{10}4s^2$). The variation or irregularity occurring in the values of I.E. across the series are mainly due to the changes in atomic radii because of the screening effect of extra electrons added to 3d-subshell which is exerted on the nuclear charge.

On account of the factors given above, the elements of first transition series show less reactivity.

d) Standard Electrode Potentials and Reducing Properties

The standard reduction potentials of the elements of 3d-series except copper are lower than that of standard hydrogen electrode.

Element	Sc	Ti	V	Cr	Mn	Fe	Co	Ni	Cu	Zn
E°_{R} (volts)	-2.10	-1.60	-1.20	-0.74	-1.18	-0.41	-0.28	-0.25	+0.34	-0.76

These elements evolve H_2 from acids though at very low rate. $\text{M} + 2\text{H}^+ \rightarrow \text{M}^{2+} + \text{H}_2$ (g). Cu does not react with acids. It has the tendency to get reduced. Sometimes the metals are protected from the attack of acids by a thin impervious layer of an inert oxide, e.g. Cr. These metals are oxidized easily to their ions and hence are reducing agent though poor due to the obvious reasons given above.

1.5 THE BINARY COMPOUNDS OF FIRST TRANSITION SERIES ELEMENTS

Those compounds which are formed by the combination of two different elements / ions are called binary compounds. For example, oxides, sulphides, halides, phosphides, carbides, nitrides, etc.

1.5.1 Oxides

The elements of the 3d-transition series react with oxygen at high temperature to give oxides. These oxides are less basic and less soluble in water. Oxides in lower oxidation states are ionic and basic, in the intermediate oxidation states their nature is amphoteric and in higher oxidation states, ionic nature decreases and covalent nature increases thereby increasing the acidic character of the oxides. It means the acidity of a salt depends on its covalent nature which in turn is based on the oxidation state of the element. Thus, oxidation state \propto covalent nature \propto acidic nature. Accordingly, the oxides may be classified as (a) basic oxides, (b) amphoteric oxides and (c) acidic oxides.

- (a) **Basic oxides** are those which are formed by the metals in the lower oxidation states. These are ionic in nature, soluble in non-oxidising acids, e.g. HCl. For example, TiO, CrO, MnO, FeO, Cu₂O, CoO, NiO, etc.
- (b) **Amphoteric oxides** are the oxides containing the metals in the intermediate oxidation states. These oxides are also soluble in non-oxidising acids, e.g., HCl. Examples TiO₂, VO₂, Cr₂O₃, Mn₃O₄, MnO₂, CuO, ZnO, etc.
- (c) **Acidic oxides** are of weak acidic nature and are formed by the elements in higher oxidation states. These are soluble in bases. For example, V₂O₅, CrO₃, MnO₃, Mn₂O₇ etc.

Reducing and oxidising nature of oxides. The electron exchange property determines the redox nature of oxides. The oxide containing the metal in lower oxidation state acts as electron donor and hence is a reductant (reducing agent). As atomic number increases, the reducing property in the lower oxidation state also increases, e.g., TiO < VO < CrO. If the metal in the oxide is in higher oxidation state, the oxide is electron acceptor or oxidising agent, e.g., CrO₃, Mn₂O₇ etc.

1.5.2 Halides

The elements of 3d-transition series react with halogens at high temperature to give halides. The reactivity of halogens goes on decreasing from F₂ to I₂. Fluorides are ionic, others have ionic as well as covalent nature. Halides are formed by many of these elements in different oxidation states, e.g. TiCl₃, TiCl₄, VCl₃, VCl₅ etc.

1.5.3 Sulphides

Metal sulphides may either be prepared by direct heating the mixture of metal and sulphur or by treating metal salt solution with H₂S or Na₂S:

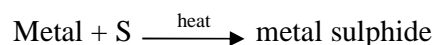

Or metal salt solution + H₂S/Na₂S → metal sulphide

Metals in low oxidation state form sulphides which are insoluble in water.

1.5.4 Carbides

Metal carbides are generally prepared by the following two methods:

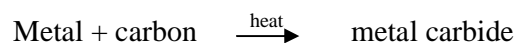

The carbides of these metals are classified as follows:

(a) Metallic or Interstitial carbides

These carbides are prepared as is given below.

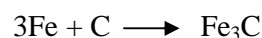
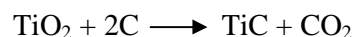
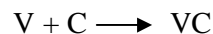

These are hard solids, have metallic properties like lustre, are stable at high temperature, chemically inert and are conductors. Ni does not form carbide. In solid state, these have tetrahedral or octahedral voids which are occupied by carbon atoms.

(b) Salt-like carbides

These carbides are limited to Sc, Cu and Zn only and are ionic in nature:

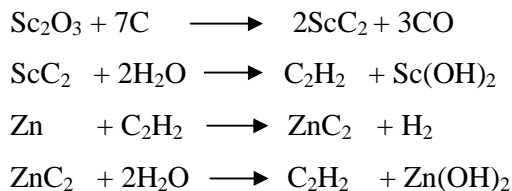

1.6 RELATIVE STABILITY OF OXIDATION STATES OF THE ELEMENTS OF FIRST TRANSITION SERIES

The stability of an element is determined by its electronic configuration. The elements of the 3d-transition series, generally exhibit variable oxidation states and are more stable in a particular oxidation state, e.g., $\text{Ti}^{4+} > \text{Ti}^{3+}$ and $\text{Fe}^{3+} > \text{Fe}^{2+}$ etc. Generally, lower oxidation states are less stable than the higher oxidation states. This relative stability depends on many factors:

- (a) Filled, half-filled and vacant d-orbitals present in the compound, i.e. d^{10} , d^5 and d^0 configurations are more stable than other configurations, e.g. $\text{Ti}^{4+}(d^0) > \text{Ti}^{3+}(d^1)$; $\text{Mn}^{2+}(d^5) > \text{Mn}^{3+}(d^4)$. However, it is not always true, e.g. $\text{Cu}^+(3d^{10})$ is less stable than $\text{Cu}^{2+}(3d^9)$ due to high lattice energy and solvation energies of Cu^{2+} in solid state and in solution.
- (b) Higher oxidation states become less stable as atomic number increases. For example, $\text{Sc}^{3+} > \text{Ti}^{3+} > \text{V}^{3+} > \text{Cr}^{3+} > \text{Mn}^{3+} > \text{Fe}^{3+} > \text{Co}^{3+} > \text{Ni}^{3+} > \text{Cu}^{3+}$.
- (c) In the binary compounds of elements of 3d-transition series, it has been observed that halogens and oxygen also illustrate the trend in stability. Generally, the group oxidation state for many elements is brought out more readily by oxygen than fluorine, the strongest halogen. This may be because fewer oxygen atoms are required than fluorine atoms to achieve the same oxidation state. For example, the group oxidation state (+7) of Mn is achieved in MnO_4^- , but MnF_7 has never been prepared. In the d-block elements, the oxidation states can be stabilised by complex formation. Low oxidation states are less stable and ligands like CN^- , N_2 , NO , CO , C_6H_6 , C_2H_4 etc. called π -acceptors form complexes in these low oxidation states to stabilise them. These complexes are known as π -complexes, e.g. $[\text{Ni}(\text{CO})_4]$, $[\text{Cr}(\text{C}_6\text{H}_6)_2]$, $[\text{Fe}(\text{C}_5\text{H}_5)_2]$ etc. Higher oxidation states are stabilized by complex formation with highly electronegative ligands.

- (d) The compounds in any oxidation state of the metal are regarded as stable if they have free existence, are not oxidised by air, are not hydrolysed by water vapour, do not disproportionate or decompose at normal temperature.

1.7 THE COMPLEXES OF THE FIRST TRANSITION SERIES ELEMENTS, THEIR COORDINATION NUMBER AND GEOMETRY

The elements of first transition (3d) series fulfill all conditions of complex formation and thus are most suitable for this purpose. The general representation for the complexes is as follows:

$[M \leftarrow L_n]^{x\pm}$ where n represents the number of lone pairs accepted by the central metal atom/ion from the ligands (L) and x is the charge on the metal complex which may be positive or negative or even zero in neutral complexes. All the elements of this series form complexes with a variety of ligands, e.g. $[CrCl_2(H_2O)_4]^+$, $[Fe(CN)_6]^{3-}$, $[Ni(NH_3)_6]^{2+}$, $[Co(H_2O)_6]^{2+}$, $[Co(NH_3)_3(SCN)_3]$, $[Cu(NH_3)_4]^{2+}$, $[Ag(NH_3)_2]^+$ etc. The elements of this series form stable complexes with N, O, and halogen donor ligands.

Coordination Number (CN)

The number of ligands (monodentate only) directly attached to the central metal atom / ion or more appropriately the number of lone pairs of electrons accepted by the central metal atom / ion from the ligands (mono as well as polydentate) in the process of the formation of the complexes (molecules or ions), is known as the coordination number (C.N.) of the metal. In the above examples, the C.N. of Ag^+ ion is 2, that of Cu^{2+} ion is 4, for Cr^{3+} , Ni^{2+} , Co^{3+} , Co^{2+} and Fe^{3+} ions it is 6. The central metal atom / ion and attached ligands are kept within the square brackets called coordination sphere. With the polydentate ligands the metal atom / ions form ring type complexes known as **chelates** (meaning claw).

Geometry of the Complexes

The coordination number of the central metal atom/ion of the complex is intimately related with its geometry. The relationship may be shown as follows:

C.N.	Geometry of the complex
------	-------------------------

- 2 Linear: Cu^+ and Ag^+ complexes, e.g. $[\text{Ag}(\text{NH}_3)_2]^+$
- 4 Tetrahedral: Mn^{2+} , Co^{2+} , Fe^{2+} , Ni^{2+} , Cu^{2+} complexes with weak ligands viz. H_2O , Cl^- , Br^- , I^- etc., e.g. $[\text{MnCl}_4]^{2-}$, $[\text{MnBr}_4]^{2-}$, $[\text{NiCl}_4]^{2-}$, $[\text{CuCl}_4]^{2-}$, $[\text{FeCl}_4]^{2-}$ etc.
- Square planar: Ni^{2+} , Cu^{2+} complexes with strong ligands viz. CN^- , NH_3 , en, dmg etc., e.g. $[\text{Ni}(\text{dmg})_2]$, $[\text{Cu}(\text{en})_2]^{2+}$, $[\text{Cu}(\text{NH}_3)_4]^{2+}$, $[\text{Ni}(\text{CN})_4]^{2-}$ etc.
- 6 Octahedral: Cr^{2+} , Cr^{3+} , Mn^{2+} , Fe^{2+} , Fe^{3+} , Co^{2+} , Co^{3+} , Ni^{2+} complexes with weak and strong field ligands, e.g. $[\text{Cr}(\text{H}_2\text{O})_6]^{3+}$, $[\text{Mn}(\text{H}_2\text{O})_6]^{2+}$, $[\text{Ni}(\text{NH}_3)_6]^{2+}$, $[\text{Co}(\text{NH}_3)_6]^{3+}$, $[\text{Co}(\text{en})_3]^{3+}$ etc.

It may be recalled that octahedral complexes of the metal ions with weak field ligands are outer orbital (also called high spin) complexes involving sp^3d^2 hybridisation and those with strong field ligands are inner orbital (also known as low spin) complexes, the central ion undergoing d^2sp^3 hybridisation.

1.8 SUMMARY

In contrast to main group elements, the last electron in the atoms of d-block elements enters the (n-1)d-subshell which influences the characteristics and periodicity in properties of transition elements. Hence, the text material of this unit is related with characteristic properties in general of d-block elements such as their electronic configuration, variable oxidation states, complex formation tendency, magnetic properties, formation of coloured ions / compounds, catalytic activity, formation of interstitial and non-stoichiometric compounds, alloy formation, metallic character, melting and boiling points, atomic and ionic radii, ionization energies, reactivity, standard electrode (reduction) potential and reducing properties. The above properties have also been discussed for the elements of the first transition (3d) series in brief giving examples where ever possible. A brief but concrete account of binary compounds of elements of 3d-series along with relative stability of their oxidation states, their complexes, coordination number and geometry of the complexes has also been given.

1.9 TERMINAL QUESTIONS

1. Give a brief note on the factor responsible for anomalous electronic configuration of Cr and Cu.
2. What accounts for the complex formation tendency of d-block elements?
3. Write a short note on the paramagnetism shown by d-block elements.
4. Why do 3d-series elements form coloured ions and compounds?
5. What are the non-stoichiometric compounds?
6. What are alloys? Give any two examples.
7. "Mn and Cr have highest number of oxidation states among first transition (3d) series elements". Comment.
8. Which one is more stable: Ti^{4+} or Ti^{3+} ?
9. μ_{eff} for a metal ion with 3 unpaired electrons is
 - a) 1.73 B.M.
 - b) 2.83 B.M.
 - c) 3.87 B.M.
 - d) 4.90 B.M.
10. Finely divided Ni is used in
 - a) The manufacture of H_2SO_4
 - b) The manufacture of HNO_3
 - c) The manufacture of NH_3
 - d) The hydrogenation reactions
11. Brass is an alloy of
 - a) Cu-Zn
 - b) Cu-Fe
 - c) Cr-Ni
 - d) Mn-Fe
12. MnO_2 is
 - a) An acidic oxide
 - b) An amphoteric oxide
 - c) A basic oxide
 - d) None of the above

1.10 ANSWERS

1 to 7: please refer to the text

8. Ti^{4+} ($3d^0$) is more stable than Ti^{3+} ($3d^1$)

9. c

10. d

11. a, 12. b

UNIT 2- CHEMISTRY OF THE ELEMENTS OF SECOND TRANSITION (4d) SERIES

CONTENTS:

- 2.1 Objectives
- 2.2 Introduction
- 2.3 General characteristics
- 2.4 Comparative study with their 3d analogues in respect to
Ionic radii, oxidation state, magnetic behavior
- 2.5 Spectral properties and stereochemistry
- 2.6 Summary
- 2.7 Terminal Questions
- 2.8 Answers

2.1 OBJECTIVES

The course material of this unit is being written with the objective of making it easy for the learners to understand the general characteristics of the elements of second transition (or 4d) series such as their electronic configuration, variable oxidation states, complex formation tendency, magnetic properties, formation of coloured ions / compounds, catalytic activity, formation of interstitial and non-stoichiometric compounds, metallic character and alloy formation as well as other periodic properties such as atomic and ionic radii, melting and boiling points, ionization energies and reactivity, standard electrode potential and reducing properties, etc. with their variation along the series.

The comparative study of some of the above periodic properties, *viz.*, ionic radii, oxidation states and the magnetic behaviour of these elements with those of their 3d analogues is also aimed at. The spectral properties and stereochemistry of these elements and their compounds or complexes is also to be discussed to make the readers familiar with these fascinating aspects.

2.2 INTRODUCTION

The series of ten elements starting from yttrium, the element of Group 3 and ending at cadmium, the element of Group 12, constitutes the second transition series. These elements with their symbols and atomic numbers are given here:

Yttrium (Y, Z = 39), zirconium (Zr, Z = 40), niobium (Nb, Z = 41), molybdenum (Mo, Z = 42), technetium (Tc, Z = 43), ruthenium (Ru, Z = 44), rhodium (Rh, Z = 45), palladium (Pd, Z = 46), silver (Ag, Z = 47) and cadmium (Cd, Z = 48). These elements are also known as the elements of 4d transition series because the differentiating or the last electron in the atoms of these elements enters the 4d subshell progressively giving $4d^1$ to $4d^{10}$ configurations, respectively. All the characteristic properties of d-block elements are exhibited by the members of this series also. These elements are the next higher analogues of first transition series elements and are less important. This series lies between strontium (Sr, Z = 38) of s-Block (Group 2) and indium (In, Z = 49) of p-Block (Group 13) so that the gradual transition of properties may occur from s- to p- Block elements in the period.

2.3 GENERAL CHARACTERISTICS OF SECOND TRANSITION (4D) SERIES ELEMENTS

All the general characteristics of the d-Block elements are applicable to the elements of second transition series though to the lesser extent. These are discussed below:

2.3.1 Electronic Configuration and Variable Oxidation States

In yttrium 4d-subshell begins filling, its valence shell configuration being $4d^1 5s^2$. The filling of 4d-subshell continues as we move along the series towards the last element, Cd which has $4d^{10} 5s^2$ valence shell configuration. There are observed pronounced irregularities in the valence shell configurations of these elements which have the general valence shell configuration $4d^{1-10} 5s^{1,2}$. Except for the last three elements, viz., Pd, Ag and Cd which have completely filled 4d-subshell ($4d^{10}$), all have incomplete d-subshells. Y, Zr, Tc and Cd have 2 electrons in 5s-subshell ($5s^2$) but Nb, Mo, Ru, Rh and Ag have only one electron, i.e., $5s^1$, in the last shell and Pd does not have any 5s- electron ($5s^0$). The anomalous valence shell configuration of Pd (i.e. $4d^{10} 5s^0$) is due to the shifting of both 5s-electrons to 4d-subshell so that it has

completely filled state (i.e., $4d^{10}$) and becomes stable, though no satisfactory explanation is available for this shifting. For the elements which have partly filled 4d-subshell but still have only one electron in 5s subshell ($5s^1$), the anomalous behaviour has not been explained with effective reasoning, only it is said for these elements that the nuclear-electron and electron-electron interactions play significant role for this behaviour. In Mo ($4d^5$) and Ag ($4d^{10}$), one electron is said to have shifted from 5s to 4d subshell to make the atoms of these elements extra stable due to exchange energy effect as has been given earlier for Cr and Cu elements of 3d- transition series.

Like the elements of first transition (3d) series, the elements of this series also exist in various oxidation states in their compounds. This is because of the availability of several electrons in 4d and 5s subshells whose energies are fairly close to each other. Hence, under different experimental conditions different number of electrons can be used from both the subshells for bonding.

It has been found for second transition series elements that the higher oxidation states become more stable. This can be illustrated by taking Fe and its next higher analogue, Ru. Fe shows +2 and +3 stable oxidation states and +4 and +6 unstable states but Ru has +2, +3, +4 and +6 as stable oxidation states while +5, +7 and +8 are unstable states for this element. The first element Y (+3) and the last element Cd (+2) exhibit only one oxidation state (though Sc in 3d transition series has also been assigned a very uncommon oxidation state of +2) because of the stable valence shell configuration of the ions, $Y^{3+} [Kr]4d^05s^0$ and $Cd^{2+} [Kr]4d^{10}5s^0$. All other elements show a variety of oxidation states, both stable and unstable, the variability being the maximum towards the middle of the series as happens in case of elements of 3d-transition series. Ruthenium, lying almost in the middle of the series, exhibits maximum number of oxidation states (i.e. 7) among all the elements of the series, including the unstable ones, ranging from +2 to +8 (i.e. +2, +3, +4, +5, +6, +7, +8). Up to Ru, the next higher member of Fe group, the highest oxidation state is equal to the group number, e.g., Sc: + 3 (Group 3); Zr: +4 (Group 4); Nb: +5 (Group 5), Mo: +6 (Group 6), Tc: +7 (Group 7) and Ru: +8 (Group 8) but the latter members of the series do not follow this trend. The lowest oxidation state is +1 only for Ag, the next congener of Cu. For Ru, Pd and Cd, the lowest oxidation state is +2, and +3 is the

lowest oxidation state for other members of the series. This has been shown in the table below.

Element	Y	Zr	Nb	Mo	Tc	Ru	Rh	Pd	Ag	Cd
Group number	3	4	5	6	7	8	9	10	11	12
Lowest oxidation state	+3	+3	+3	+3	+4	+2	+3	+2	+1	+2
Highest oxidation state	+3	+4	+5	+6	+7	+8	+6	+6	+3	+2

Thus, it is concluded that the electronic structure of the atoms of the second transition series elements does not follow the pattern of the elements of the first transition series and also among the 4d series elements, the higher oxidation states become more pronounced and stable.

2.3.2 Complex Formation Tendency

The availability of various oxidation states facilitates the complex formation tendency. The complex formation tendency is found in the elements of second transition series also though it is less pronounced. These metals are weakly electropositive and do not form stable complexes with wide range of ligands as is found in case of first transition series elements. These elements form stable complexes with P, S and heavier halogens as donor atoms in the ligands in contrary to the elements of 3d series. They also form π complexes with CO as ligand. The 4d series elements show the common as well as unusual coordination numbers in their complexes which may be 4, 6 and even more than six. The examples are available for most of the second transition series elements in various oxidation states.

Yttrium forms complexes readily with NCS^- , acac, EDTA etc., viz., $[\text{Y}(\text{NCS})_6]^{3-}$, $[\text{Y}(\text{acac})_3 \cdot \text{H}_2\text{O}]$, $[\text{Y}(\text{EDTA})]^-$, respectively. Its complexes with C.N. 8 are also known.

Zirconium usually gives halo complexes of the type $[\text{ZrX}_6]^{2-}$ and $[\text{ZrX}_7]^{3-}$ (X = halide ions), $[\text{Zr}(\text{acac})_4]$, $[\text{Zr}(\text{C}_2\text{O}_4)_4]^{4-}$, $[\text{Zr}(\text{bipy})_3]$ and also $[\text{Zr}_2\text{F}_{13}]^{5-}$ and $[\text{ZrCl}_4]_3(\text{POCl}_3)_2$ type.

Niobium forms clusters only, e.g. $[\text{Nb}_6\text{X}_{12}]^{n+}$, where $n = 2, 3$ or 4 ; $[\text{Nb}_6\text{X}_{14}]$, $[\text{Nb}_6\text{X}_{15}]$ and $[\text{Nb}_6\text{X}_{16}]$, etc.

Molybdenum forms a variety of complexes having Mo in different oxidation states and coordination numbers. For example, $[\text{Mo}_2\text{Cl}_8]^{4-}$, $[\text{Mo}_2\text{Cl}_9]^{3-}$, $[\text{MoCl}_6]^{2-}$, $[\text{Mo}(\text{CO})_5]^{2-}$, $[\text{Mo}_2(\text{CO})_{10}]^{2-}$, $[\text{Mo}(\text{CO})_6]$, $[\text{Mo}(\text{CNR})_7]^{2+}$, $[\text{Mo}(\text{CN})_8]^{4-}$, $[\text{Mo}(\text{S}_2\text{CNMe}_2)_4]$, etc.

Technitium also forms many complexes though not as many as are formed by manganese and rhenium. For example, $[\text{Tc}(\text{CO})_4]^{3-}$, $[\text{Tc}(\text{CO})_5]^-$, $[\text{Tc}_2(\text{CO})_{10}]$, $[\text{Tc}(\text{CN})_7]^{4-}$, $[\text{Tc}(\text{CN})_6]$, $[\text{Tc}(\text{NCS})_6]^-$, $[\text{TcH}_9]^{2-}$ etc.

Ruthenium forms a variety of complexes both with normal and π -ligands, such as N_2 , CO etc. For example, $[\text{Ru}(\text{NH}_3)_5\text{N}_2]^{3+}$, $[\text{Ru}(\text{NH}_3)_6]^{3+}$, $[\text{Ru}(\text{CO})_5]$, $[\text{Ru}_3(\text{CO})_{12}]$ etc. The first complex further gives polynuclear complex (N_2 is weak π -ligand):

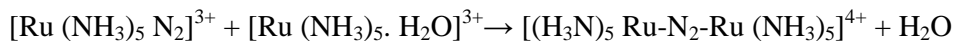

The complexes of Rh, Pd and Cd are as follows:

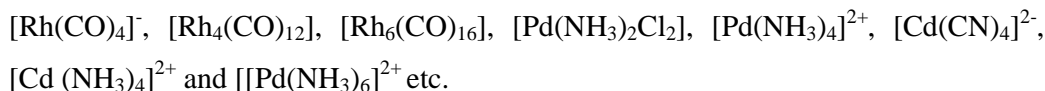

2.3.3 Magnetic Properties

The elements of second transition series exhibit paramagnetism due, obviously, to the presence of unpaired d-electrons in elemental or ionic forms. It has been observed that the magnetic moment, a measure of magnetism in the substances, increases with the number of unpaired electrons (the relationship of magnetic moment, μ_{eff} and number of unpaired electrons has been given in Unit 1 under magnetic properties of 3d-series elements). The relationship is called **spin only formula** because only spin contribution towards the total magnetic moment is considered and orbital contribution is regarded as quenched. However, if the orbital contribution is also considered in its full capacity to the total magnetic moment then the magnetic moment of the substance can be calculated by the formula:

$$\mu_{\text{eff}} = \sqrt{4S(S+1) + L(L+1)}$$

Where S is resultant spin angular momentum and L is the resultant orbital angular momentum.

In the ions/compounds/complexes of second transition series elements, the spin only formula is used to calculate the number of unpaired electrons from μ_{eff} values.

2.3.4 Formation of Coloured Ions / Compounds.

The elements of the second transition series also form coloured ions / compounds / complexes whether in solid or in solution state, due to usual reasons as have been given for those of first transition series as well as for general d-block elements. The cations having vacant or completely filled d-orbitals (d^0 or d^{10}) are colourless in the case of this series also. But, those with partly filled d-orbitals ($d^1, d^2, d^3, \dots, d^9$) are coloured. It means the cations having all the electrons paired in d-orbitals or no electrons in this subshell are colourless but those cations / compounds having unpaired (some or all) in d-orbitals are coloured. If n is the number of unpaired electrons in d-subshell, then the ions having $n = 0$ are colourless while those having $n = 1, 2, \dots, 5$ are coloured. In addition to the presence of unpaired electrons in d-subshell or incomplete d-subshell, the nature of atoms (in the compounds) or ligands (in the complexes) attached to central metal ion determines the colour of the compounds as a whole.

As has been explained earlier, the colour in the substances is developed due to the movement of electrons from one d-orbital to another under the influence of visible light falling on the substance. The colour is intense if the transition is allowed but becomes dull if it is forbidden. If in place of inter orbital transition, inter atomic transitions take place, intense colours are produced because such transitions are not affected by the selection rules (*viz.* spin, Laporte and symmetry selection rules) thereby allowing free transition of electrons.

2.3.5 Catalytic Activity

Like the elements of first transition series, those of second transition series also show catalytic activity, some of them being very important and useful as catalysts in a variety of reactions of industrial importance. This is because these are capable of forming inter mediate products with the reactants or have active centres on their

surface in the activated state which can activate the reactants for the desired reactions. For example,

- (a) Pd is used in the hydrogenation of phenol to cyclohexanol.
- (b) Pd/Pt catalyses the hydrogenation of unsaturated hydrocarbons.
- (c) Mo is used as a promoter in the manufacture of ammonia by Haber process.
- (d) Pt/Rh is used as catalyst in the oxidation of NH_3 to NO (manufacture of HNO_3).

2.3.6 Formation of Interstitial and Non-stoichiometric compounds.

The metals of second transition series, in general, form interstitial compounds with small non-metallic elements such as H, N, C etc. The lattice of these metals is capable of accommodating these small atoms between the metal atoms with no change in the lattice structure. Examples are: $\text{PdH}_{0.6}$, $\text{ZrH}_{1.98}$, ZrC, NbC, MoC, Mo_2C , ZrN, NbN, Mo_2N etc. These compounds have conductivity properties and are hard, thus behaving as alloys.

These elements also form non-stoichiometric compounds which often exhibit semi conductivity, fluorescence and have centres of colours. Above examples of PdH and ZrH_2 also furnish the examples of non-stoichiometry. Apparently the molecular formula of these compounds does not correspond to M: H ratio of 1:1 and 1:2. Actually, the M: H ratio in these compounds is 1: 0.6 and 1:1.98, respectively.

2.3.7 Metallic character and Alloy Formation.

All the elements of second transition series are metals which are hard, some of them malleable and ductile (e.g., Ag), fairly good conductors of heat and electricity. They crystallize in one of the following lattice structures: body centred cubic (bcc), face centred cubic (fcc) or hexagonal close packed (hcp).

The elements of this series also form alloys though to the lesser extent than the elements of first transition series due to the obvious reasons as given earlier. These alloys are also usually harder and have higher melting points than parent metals. They are also corrosion proof/resistant.

These metals are less important than those of the first and third transition series.

2.3.8 Periodic Properties and Their Variation along the Series

The periodic properties of second transition series elements such as the atomic radii, ionic radii, atomic volumes, ionization energies, melting and boiling points, standard electrode potentials, reactivity and reducing properties also vary along the series from the first element Y to the last element Cd. These have been discussed below along with their variation in the series.

(a) Atomic Radii, Atomic Volumes and Ionic Radii

It has been observed that the atomic radii of the elements of second transition series, though not known with certainty, decrease from the first element, Y to Rh, the next congener of Co and increase thereafter up to the last element, Cd. The values are very close from Mo to Pd because of the increased screening effect of the 4d electrons which more or less counter balance the nuclear pull exerted on the 5s electrons. Then the screening effect becomes more and more pronounced thereby decreasing the attractive force between the nucleus and the outer electrons. As a result, atomic radii of Ag and Cd are increased. Cd has next highest atomic radius which is only lower than that for Y. These values have been given below:

Elements	Y	Zr	Nb	Mo	Tc	Ru	Rh	Pd	Ag	Cd
Atomic radii (pm)	162	145	134	130	127	125	125	128	134	148

The atomic volumes of these elements which are dependent on the atomic radii show the same trend in their variation. The atomic volumes are being listed below:

Elements	Y	Zr	Nb	Mo	Tc	Ru	Rh	Pd	Ag	Cd
Atomic volume (Cm ³)	19.8	14.0	10.8	9.4	-	8.3	8.3	8.9	10.3	13.0

For Tc its value has arbitrarily been calculated but is not known with certainty. The values decrease from the first element, Y, upto Rh and then increase due to the obvious reason, i.e. increasing atomic radii values.

The ionic radii follow almost the same trend as the atomic radii at least for the few elements. These elements form ions of variety of oxidation states but only those ions may be considered which bear the same charge. This analogy does not apply to the ions of these elements. For various ions, the ionic radii are listed here:

Ions	Y ³⁺	Zr ⁴⁺	Nb ⁵⁺	Mo ⁴⁺	Tc ⁴⁺	Ru ³⁺	Rh ³⁺	Pd ²⁺	Ag ⁺	Cd ²⁺
Ionic radii (pm)	104	86	70	79	-	81	80	80	123	97

As is evident from this table, ionic radii values are showing an irregular trend particularly for the later elements.

(b) Melting and Boiling Points

The melting and boiling points of these elements are generally very high, almost similar to those of the elements of first transition series except for a few elements which have very high values, e.g., Nb to Ru (see the table given below). The last element Cd, has exceptionally low value of melting point even lower than that of Zn. This may be attributed to its high atomic volume, almost one and half times to that of Zn. This results in weaker metallic bonding in the metal lattice of Cd. Melting point values of these elements are as follows:

Element	Y	Zr	Nb	Mo	Tc	Ru	Rh	Pd	Ag	Cd
Melting point (°C)	1490	1860	2415	2620	2200	2450	1970	1550	960	321

The highest melting point is for Mo followed by Ru and other elements have comparable values of melting point. Cd has the lowest value. These elements have very high boiling points, greater than 2200°C except for Cd (765°C).

(c) Ionization Energies and Reactivity

The first ionization energies of these elements generally increase from the first element to the last one with a marked drop in the value for Ag. The values are listed below:

Element	Y	Zr	Nb	Mo	Tc	Ru	Ph	Pd	Ag	Cd
First ionization energy (kJ/mol)	636	669	664	694	698	724	745	803	732	866

These high values of first ionization energies can be correlated with the values of atomic radii which generally decrease along the series and the screening effect increases; therefore, the elements accordingly have higher values. For Ag low value is attributed to slightly higher atomic radius and availability of a single 5s electron. Appreciably higher value of ionization energy for Cd is due to the stability associated with filled 4d and 5s subshells ($4d^{10}5s^2$).

As discussed in section 1.3 above, various factors are responsible for low reactivity of the elements of second transition series. They are even less reactive than those of the first transition series.

(d) Standard Electrode Potentials and Reducing Properties

As is well known that the standard electrode potential (reduction) is related with the reducing properties of the elements, in general. Metals with negative values of standard electrode potential as compared to standard hydrogen electrode for which E^0 value is taken as zero, act as reducing agents. Such metals can displace hydrogen gas from dilute acids. For the metals with negative E^0 values but not reacting with acids, some other factors also play an important role such as formation of protective coating on the metal surface and making it unreactive. Strong reducing properties of metals make them displace other metal ions from their solutions. Though standard electrode potential values are available only for a few elements of this series, these are given below:

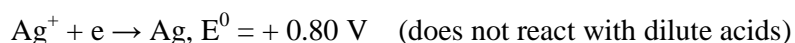
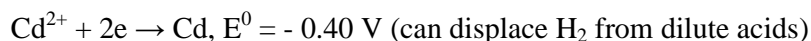

From the above, it can be concluded that Cd^{2+} ions can give up the electrons and act as reducing agents while Ag^+ ions do not give the electrons, rather take up the electrons easily. Hence, act as oxidizing agents when react with reducing ions, e.g.,

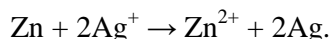

2.4 COMPARATIVE STUDY OF THE ELEMENTS OF THE SECOND TRANSITION SERIES AND THOSE OF FIRST TRANSITION SERIES

(a) Oxidation States

The elements of both the transition series exhibit variable oxidation states. Some of them are common and the others are uncommon or unfamiliar oxidation states. It may be recalled that for the elements of first transition (or 3d) series, generally lower oxidation states (*viz.* +2, +3, etc.) are most stable while the higher oxidation states are less stable. That is why their compounds in the higher oxidation states are less stable and more reactive. For example, $\text{Cr}_2\text{O}_7^{2-}$ (Cr in +6 oxidation state) and MnO_4^- (Mn in +7 oxidation state) are strong oxidising agents and in their reactions get reduced to Cr^{3+} and Mn^{2+} states, which are stable, respectively. We can say that lower (+2 and +3) oxidation states generally dominate the chemistry of the first transition series elements, e.g., Co^{2+} ion is quite stable in aqueous medium as well as Co^{3+} in $[\text{Co}(\text{NH}_3)_6]^{3+}$ ion is highly stable. On the other hand, Rh^{2+} ion, next congener of Co is hardly known. Similarly no such complex of Rh^{3+} is known as is formed by Co^{3+} ion with NH_3 .

For the elements of second transition series, lower (+2 and +3) oxidation states are of relatively little importance but the higher oxidation states (e.g., +5, +6, +7, etc) are stable and important. For example, in manganese group (Group 7), Mn^{2+} ion is stable while Tc^{2+} ion is unstable; Tc^{3+} occurs in some π -complexes and clusters only. In Group 6, Cr (III) forms a large number of compounds and complexes, while Mo (III) forms only a few. Cr (VI) ions are less stable (as discussed above), but Mo (VI) ions are highly stable: $[\text{MoO}_4]^{2-}$ ion is not easily reduced. In Group 7, again $[\text{MnO}_4]^-$ is unstable but $[\text{TcO}_4]^-$ is stable and very weak oxidising agent. Similarly, FeO_4 , CrCl_6 and NiF_6 are not known, while RuO_4 , MoCl_6 etc. are quite stable. The highest oxidation state for 3d-series elements is +7 (in MnO_4^-), but for 4d-series members it is +8 (in RuO_4).

(b) Ionic Radii

In terms of the ionic radii, it has been observed that the radii of 3d-series elements are smaller than those of 4d-series elements, i.e. r_{3d} ions < r_{4d} ions. The comparative table of ionic radii of the elements of the two series is being given here:

Ions:	Sc^3	Ti^{4+}	Cr^{4+}	Zn^{2+}
Radii (pm):	81	75	68	74

Ions:	Y ³⁺	Zr ⁴⁺	Mo ⁴⁺	Cd ²⁺
Radii (pm)	104	86	79	97

This is due to the change in the value of n from 3 to 4 for the two series of elements.

(c) Magnetic Behaviour

It has been observed that the magnetic properties of the first transition series elements could be easily interpreted and the magnetic moment of their ions/atoms or compounds can be represented by the spin only formula which gives the idea of the number of unpaired electrons in them. From this, the geometry of the complexes of these elements could be explained.

But the magnetic behaviour of the second transition elements is more complex and difficult to use the spin-only formula to get the number of unpaired electrons or the magnetic moment because the orbital contribution could not be ignored outrightly for the compounds / complexes of these elements.

This is because 4d-orbitals are too much spread out in space and as a result the inter electronic repulsions in these are much less as compared to first transition series orbitals. A given set of ligands produces very large crystal field splitting energy in 4d-orbitals than in 3d-orbitals. Therefore, heavier elements of this series will tend to give low-spin or inner orbital complexes as compared to those of first transition series which form mainly high-spin (or outer orbital) complexes.

2.5 SPECTRAL PROPERTIES AND STEREOCHEMISTRY OF THE ELEMENTS OF THE SECOND TRANSITION SERIES

We know that the electromagnetic radiations of white light such as sunlight consist of a continuous spectrum of wavelengths corresponding to different colours. If such a light falls on a compound, the light-matter interaction results in the absorption of either all the radiations giving black colour to the compound, or that of one radiation of a particular colour. In the latter case, the light of different colour is transmitted or reflected which is the complementary colour of the absorbed colour

and is the colour of the compound. If the compound does not absorb in the visible region, it appears white.

The transition metal ions / compounds / complexes show a variety of colours depending on the nature of metals and ligands. The colour of a compound arises due to the transition of electron(s) from ground state (lowest energy) to the excited state (higher energy). When a photon having energy equal to the difference between the two states, i.e., ground and excited state, strikes the compound or the ion, electronic transition (here promotion) takes place. In the complexes of the transition metals, this transition occurs from t_{2g} to e_g level in octahedral field and from e to t_2 level in tetrahedral ligand environment. The energy difference between the two states involved in electronic transition is given by (as given in the figure 2.1) the following:

$$\Delta E = E_2 - E_1 = h\nu = \frac{hc}{\lambda} = h\nu \left(\because \nu = \frac{1}{\lambda} \right)$$

Where ΔE = energy, h = Planck's constant, c = velocity of light, λ = wavelength of light absorbed, ν = frequency of light absorbed and ν = wave number. //

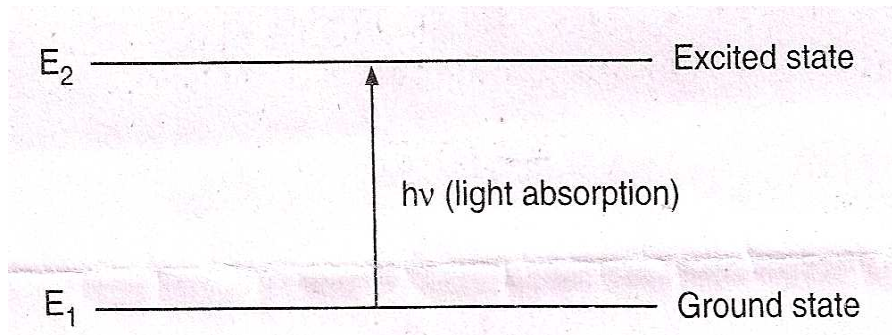

Fig. 2.1

The colour of the compound / complex exhibited due to the above transition is called the colour due to d-d transition. The examples of compounds / complexes which are coloured due to d-d transitions are provided by first transition (3d) series elements and a few heavier elements. Greater is Δ , more energy is required to cause the d-d transition. For 4d-series elements, increasing Δ value in octahedral field is: $\text{Mo}^{3+} < \text{Rh}^{3+} < \text{Ru}^{3+} < \text{Pd}^{4+}$ etc.

The other types of electronic transitions which are responsible for the colours of the ions / compounds / complexes, particularly, of second transition (4d) series elements are the charge transfer processes (C.T.) from metal to ligand or ligand to metal. The electronic spectra of the complexes / compounds of second and third transition series elements are less important than those of the complexes of first transition series elements because in the former case the d-d and C.T. bands can not be separated but this is possible in the latter case. In the compounds / complexes of heavier elements of 4d series because of the larger magnitude of Δ (Crystal field splitting energy), the d-d bands are found at lower wave lengths and hence overlap with the C.T. bands. The charge transfer process is similar to the internal redox process because electron transfer takes place during this process from metal to ligand or ligand to metal within a complex/compound. In heavier transition metal complexes the latter is generally observed. Thus, it is possible to classify and rank the metal ions according to their oxidising power $\text{Rh}^{4+} > \text{Ru}^{4+} > \text{Ru}^{3+} > \text{Pd}^{2+} > \text{Rh}^{3+}$, etc. Greater the oxidising power of the metal ion and also greater the reducing power of the ligands, lower the energy at which the C.T. bands appear.

Charge transfer transitions are Laporte and spin allowed, unlike d-d transitions, i.e., $\Delta l = \pm 1$ and $\Delta s = 0$ because in these transitions, there occurs a transition of electron(s) between the orbitals of different atoms, *viz.*, metal and ligand. These give rise to more intense or strong absorptions. When these transitions occur in visible region, the compound / complex shows intense colour.

These transitions are of four types:

- (a) Ligand to metal transitions
- (b) Metal to ligand transitions
- (c) Intervalence or metal to metal transitions
- (d) Intra ligand charge transfer

Among the oxo ions of 4d series elements, the decreasing order of energy of ligand to metal charge transfer is as follows:



But, the energy of charge transfer increases for the similar ions of 5d-series elements. For the above ions. The energy difference between 2p-orbitals of oxide ion and 4d-orbitals of the metal ions is very large lying in UV region and hence these ions are colourless.

An example of metal-metal (or inter valence) charge transfer is the Ru-complex given below: (Fig. 2.2)

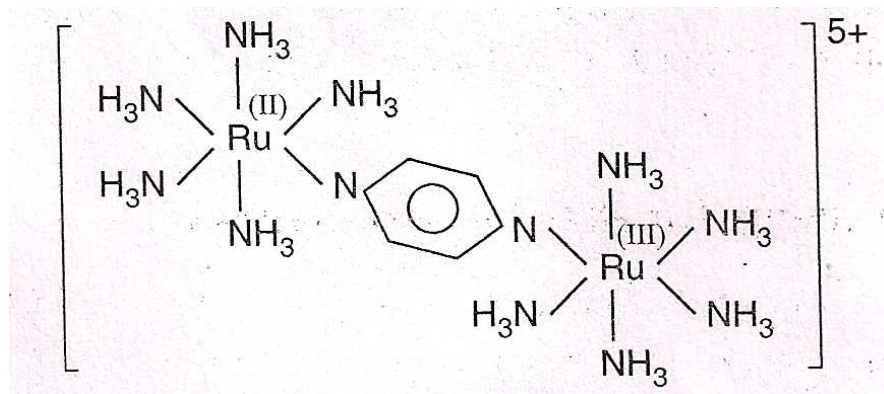

or $[(\text{NH}_3)_5\text{Ru}^{\text{II}} - \text{Pyz} - \text{Ru}^{\text{III}}(\text{NH}_3)_5]^{5+}$ where bridging ligand is pyrazine group. In this complex electronic transition occurs from Ru(II) to Ru(III) through Pyz-bridging ligand and gives intense colour. The compounds with M-M bonds also give intense colour, e.g., $[\text{Mo}_2\text{Cl}_8]^{4-}$ is red in colour. Also, the metal carbonyls with M-M bonds are often intensely coloured (e.g., polynuclear carbonyls).

Stereochemistry of the compounds and complexes

The stereochemistry of the compounds and complexes of the elements of this series may be summarized groupwise. The elements exhibit different stereochemistry depending on the oxidation state, coordination number and ligand in the particular compound / complex. For example, the stereochemistry of zirconium (Group 4) is tabulated below in Table 2.1.

Table 2.1: Oxidation states and stereochemistries of zirconium compounds

Oxidation state	Coordination number	Geometry	Examples
Zr^0	6	Octahedral	$[\text{Zr}(\text{bipy})_3]$

Zr ³⁺	6	Octahedral	ZrX ₃ (X = Cl, Br, I)
Zr ⁴⁺	4	Tetrahedral	[ZrCl ₄], [Zr(CH ₂ C ₆ H ₅) ₄]
	6	Octahedral	[ZrF ₆] ²⁻ , [ZrCl ₆] ²⁻ , [Zr(acac) ₂ Cl ₂]
	7	Pentagonal bipyramidal	[ZrF ₇] ³⁻
	8	Square antiprism Dodecahedral	[Zr(acac) ₄] [Zr(C ₂ O ₄) ₄] ⁴⁻ , [ZrX ₄ .(diars) ₂]

The stereochemistry of niobium (Group 5 element) is being summarized below in Table 2.2.

Table 2.2: Oxidation states and stereochemistries of niobium compounds

Oxidation state	Coordination number	Geometry	Examples
-3	5	Trigonal bipyramidal	[Nb(CO) ₅] ³⁻
-1	6	Octahedral	[Nb(CO) ₆] ⁻
+3	6	Trigonal prism	[NbO ₂] ⁻
		Octahedral	[Nb ₂ Cl ₉] ³⁻
	8	Dodecahedral	[Nb(CN) ₈] ⁵⁻
+4	6	Octahedral	[NbCl ₆] ²⁻
	7	Distorted pentagonal bipyramidal	K ₃ [NbF ₇]
	8	Square antiprism Dodecahedral	[Nb(SCN) ₄ (dipy) ₂] K ₄ [Nb(CN) ₈]
+5	4	Tetrahedral	[NbO ₄] ⁻

	5	Trigonal bipyramidal	[NbCl ₅], [Nb(NR ₂) ₅]
	6	Octahedral	[NbCl ₅ .OPCl ₃], [NbCl ₆] ⁻

The stereochemistry of molybdenum (Group 6 element) is given below in Table 2.3.

Table 2.3: Oxidation states and stereochemistries of molybdenum compounds

Oxidation state	Coordination number	Geometry	Examples
-2	5	Trigonal bipyramidal	[Mo(CO) ₅] ²⁻
-1	6	Octahedral	[M ₂ (CO) ₁₀] ²⁻
0	6	Octahedral	[Mo(CO) ₆], [Mo(CO) ₅ I] ⁻
+2	6	Octahedral	[Mo(diars) ₂ X ₂]
	7	Capped trigonal prismatic	[Mo(CNR) ₇] ²⁺
	9	Cluster compound	Mo ₆ Cl ₁₂
+3	6	Octahedral	[Mo(NCS) ₆] ³⁻ , [MoCl ₆] ³⁻
	8	Dodecahedral	[Mo(CN) ₇ (H ₂ O)] ⁴⁻
+4	6	Octahedral	[Mo(NCS) ₆] ²⁻
	8	Dodecahedral	[Mo(CN) ₈] ⁴⁻
+5	5	Trigonal bipyramidal	MoCl ₅
	6	Octahedral	[Mo ₂ Cl ₁₀], [MoOCl ₅] ²⁻
	8	Dodecahedral	[Mo(CN) ₈] ³⁻
+6	4	Tetrahedral	[MoO ₄] ²⁻ , [MoO ₂ Cl ₂]

	6	Octahedral	[MoO ₆], [MoF ₆]
--	---	------------	--

The stereochemistry of technetium (Group 7 element) is not much explored. Only very few examples of this element are known. Still some of them are given in Table 2.4.

Table 2.4: Oxidation states and stereochemistries of technetium compounds

Oxidation state	Coordination number	Geometry	Examples
0	6	Octahedral	[Tc ₂ (CO) ₁₀]
+2	6	Octahedral	[Tc(diars) ₂ Cl ₂]
+3	6	Octahedral	[Tc(diars) ₂ Cl ₂] ⁺
+4	6	Octahedral	[TcX ₆] ²⁻
+5	5	Square pyramidal	[TcOX ₄] ⁻
	8	Dodecahedral	[M(diars) ₂ Cl ₄] ⁺
+6	6	Octahedral	[TcF ₆]
+7	4	Tetrahedral	[TcO ₄] ⁻ , [TcO ₃ Cl]

The stereochemistry of ruthenium (Group 8 element) is being given in Table 2.5.

Table 2.5: Oxidation states and stereochemistries of ruthenium compounds

Oxidation state	Coordination number	Geometry	Examples
-2	4	Tetrahedral	[Ru(CO) ₄] ²⁻
0	5	Trigonal bipyramidal	[Ru(CO) ₅], [Ru(CO) ₃ (PPh ₃) ₂]
+2	6	Octahedral	[RuNOCl ₅] ²⁻ , [Ru(dipy) ₃] ²⁺
+3	6	Octahedral	[Ru(NH ₃) ₅ Cl] ²⁺ , [Ru(H ₂ O)Cl ₅] ²⁻

+4	6	Octahedral	$K_2[RuCl_6]$
+5	6	Octahedral	$K[RuF_6]$, $[RuF_5]_4$
+6	4	Tetrahedral	$[RuO_4]^{2-}$
	5	Trigonal bipyramidal	$[RuO_3(OH)_2]^{2-}$
	6	Octahedral	$[RuF_6]$
+7	4	Tetrahedral	$[RuO_4]^-$
+8	4	Tetrahedral	$[RuO_4]$

The stereochemistry of rhodium (Group 9 element) has been given in Table. 2.6.

Table 2.6: Oxidation states and stereochemistries of rhodium compounds

Oxidation state	Coordination number	Geometry	Examples
-1	4	Tetrahedral	$[Rh(CO)_4]^-$
+1	3	Planar	$[Rh(PPh_3)_3]ClO_4$
	4	Tetrahedral	$[Rh(PMe_3)_4]^+$
	5	Trigonal bipyramidal	$[HRh(PF_3)_4]$
+3	5	Square pyramidal	$[RhI_2(CH_3)(PPh_3)_2]$
	6	Octahedral	$[Rh(H_2O)_6]^{3+}$, $[RhCl_6]^{3-}$
+4	6	Octahedral	$K_2[RhF_6]$
+6	6	Octahedral	$[RhF_6]$

The stereochemistry of less explored element palladium (group 10) has been given in Table. 2.7.

Table 2.7: Oxidation states and stereochemistries of palladium compounds

Oxidation state	Coordination number	Geometry	Examples
0	3	Planar	[Pd(PPh ₃) ₃]
	4	Tetrahedral	[Pd(PF ₃) ₄]
+2	4	Planar	[Pd(NH ₃) ₄]Cl ₂
+4	6	Octahedral	[PdCl ₆] ²⁻

The stereochemistry of silver (Group 11 element) is being given below: Table. 2.8.

Table 2.9: Oxidation states and stereochemistries of silver compounds

Oxidation state	Coordination number	Geometry	Examples
+1	2	Linear	Ag(CN) ₂ ⁻ , Ag(NH ₃) ₂ ⁺
	4	Tetrahedral	[Ag(SCN) ₄] ³⁻ , [Ag(py) ₄]ClO ₄
	6	Octahedral	AgCl, AgF, Ag Br, (NaCl structure)
+2	4	Planar	[Ag(py) ₄] ²⁺
+3	4	Planar	[AgF ₄] ⁻
	6	Octahedral	[Ag(IO ₆) ₂] ⁷⁻ , [AgF ₆]

2.6 SUMMARY

In this unit, an effort has been made to discuss the general characteristics of the elements of the second transition series such as their electronic configuration and variation in the oxidation states, magnetic behaviour, complex formation tendency, colour of the compounds/complexes, catalytic activity, formation of interstitial and non-stoichiometric compounds, metallic character and alloy formation along with the

periodic properties and their variation across the period. A comparative account of these elements with their 3d analogues in respect to their ionic radii, oxidation states and magnetic behaviour has also been given. A brief discussion of spectral properties and a tabular account of the stereochemistry of the compounds of the elements of this series have also been recorded. It is hoped that this will enable the learners to understand the subject matter in a better and easier way.

2.7 TERMINAL QUESTIONS

1. What are the transition elements? Why are they called so?
2. Mention three main factors that enable transition elements to form complexes.
3. Write down the names and symbols of 4d and 5d congeners of element manganese.
4. Which ion is more stable Ag^+ or Ag^{2+} and why?
5. Write down the valence shell electronic configuration of Pd ($Z = 46$).
6. Write down two applications of Pd as catalyst.

2.8 ANSWERS

3. Technetium (Tc) and rhenium (Re)
4. Ag^+ ion due to $4d^{10}$ configuration
5. $4d^{10} 5s^0$

For Ans. 1, 2 & 6 please refer to the text.

UNIT-3 CHEMISTRY OF THE ELEMENTS OF THIRD TRANSITION (5d) SERIES

CONTENTS:

- 3.1 Objectives
- 3.2 Introduction
- 3.3 General characteristics
- 3.4 Comparative study with their 3d analogues
- 3.5 Ionic radii, oxidation states, magnetic behavior
- 3.6 Spectral properties and stereochemistry
- 3.7 Summary
- 3.8 Terminal Questions
- 3.9 Answers

3.1 OBJECTIVES

Objectives this unit are to make the learners understand the general characteristics of the elements of the third transition (5d) series such as their electronic configuration, variable oxidation states, complex formation tendency, magnetic properties, formation of coloured ions / compounds, catalytic activity, formation of interstitial and non-stoichiometric compounds, metallic character and alloy formation, their periodic properties such as atomic and ionic radii, melting and boiling points, ionisation energies and reactivity, standard electrode potential and reducing property along with their variation in the series.

The comparative study of ionic radii, oxidation states and magnetic behaviour of these elements with those of the 3d and 4d analogues will also be given so that the learners may understand the similarities and differences between the elements of the three series. The learners will also be acquainted to the spectral properties and stereochemistries of the compounds of these elements to make them familiar with these aspects.

3.2 INTRODUCTION

The third transition series also contains ten elements and starts at lanthanum (La, $Z = 57$), the element of Group 3, with $5d^1 6s^2$ valence shell configuration. The

next element of this series is hafnium (Hf, $Z = 72$), the element of Group 4, with $5d^26s^2$ configuration in the valence shell. In between these two d-block elements, there occurs a series of 14 elements (from $Z = 58$ to 71) which are called lanthanides because they succeed La and are closely related with it. These fourteen elements are also known as elements of 4f series. Thus 5d series element La precedes and Hf succeeds the lanthanides. After Hf the filling of 5d subshell continues in tantalum (Ta, $Z = 73$), tungsten (W, $Z = 74$), rhenium (Re, $Z = 75$), osmium (Os, $Z = 76$), iridium (Ir, $Z = 77$), platinum (Pt, $Z = 78$), gold (Au, $Z = 79$) and mercury (Hg, $Z = 80$), the element of Group 12, with $5d^{10}6s^2$ valence shell configuration. All the elements of this series have 2 electrons in 6s subshell and 5d subshell is being progressively filled with 1 to 10 electrons, except Au which has one electron ($6s^1$) due to the shifting of one s-electron to (n-1)d subshell to completely fill it (exchange energy effect). Because the last or the differentiating electron in the atoms of these elements enters the 5d subshell, the third transition series of elements is also known as 5d transition series.

These elements are much more important than those of the second transition series. This series of elements lies between barium (Ba, $Z = 56$), the elements of Group 2, and thallium (Tl, $Z = 81$), the element of Group 13 so the gradual transition of the properties occurs in the period. These elements also exhibit all the characteristic properties of the d-block elements as happens for those of first transition and second transition series.

3.3 GENERAL CHARACTERISTICS OF THIRD TRANSITION (5-d) SERIES ELEMENTS

The general characteristics of these elements are as follows:

3.3.1 Electronic Configuration and Variable Oxidation States

The elements of this series show a regular trend in the electronic configuration of the valence shell like those of first transition series. The general valence shell electronic configuration of these elements is $5d^{1-10}6s^{1,2}$. The last two elements, viz, gold and mercury have completely filled 5d-subshell (i.e. $5d^{10}$) whereas all other elements have 1 to 8 electrons, i.e., $5d^{1-8}$ in the d-subshell of penultimate shell. As has been given in the introduction, only Au has $6s^1$ configuration and all

other elements have $6s^2$ configuration in the last shell, In Au exchange energy effect plays an important role to cause the sifting of one 6s-electron to 5d-subshell so that it has stable $5d^{10}$ configuration (i.e. $5d^{10} 6s^1$ valence shell configuration) as was the case with copper (3d series) and silver (4d series).

Like the elements of first and second transition series, the elements of this series also exist in various oxidation states in their compounds, i.e., the variation of the oxidation states is equally pronounced in the elements of all the three series (i.e., 3d, 4d- and 5d-). This is due to the availability of several electrons in 5d and 6s sub shells whose energies are fairly close to each other like the elements of other series and under different conditions different number of electrons can be used from both the subshells for chemical bonding.

It has been observed that like the members of second transition series and in contrary to those of first transition series, the higher oxidation states become more stable and pronounced for the elements of this series also. The minimum oxidation state varies from +1 to +3 for these elements in general La and Hf have +3, elements in the middle have +2 and the last two elements, viz, Au and Hg have +1 minimum oxidation states. It is interesting to note that for the elements up to the middle from the left, the highest oxidation state of an element is equal to the group number of the element but this analogy does not apply to the latter elements as happens for elements of second transition series. This has been shown below:

Elements	La	Hf	Ta	W	Re	Os	Ir	Pt	Au	Hg
Group number	3	4	5	6	7	8	9	10	11	12
Lowest ox. state	+3	+3	+4	+2	+3	+2	+2	+2	+1	+1
Highest ox. state	+3	+4	+5	+6	+7	+8	+6	+4	+3	+2

From this table it is clear that the lowest oxidation state is +1 for both Au and Hg and the highest oxidation state is +8 for Os which is the highest stable oxidation state among all the transition elements.

3.3.2 Complex Formation Tendency

Most of the elements of this series also have the complex formation tendency though to a lesser extent because of the weak electropositive nature and non-availability of wide range of ligands. Still some of them form the complexes with halide, cyanide, NH_3 , H_2O and π -ligands (such as CO). The examples of the complexes are given below:

Hafnium gives complexes of the type $[\text{HfCl}_4 \cdot 2\text{POCl}_3]$, $[\text{HfF}_6]^{2-}$, $[\text{Hf}(\text{acac})_4]$, $[\text{Hf}(\text{C}_2\text{O}_4)_4]^{4+}$, etc. Ta forms complexes of the type $[\text{Ta}(\text{CO})_6]^-$, $[\text{TaCl}_6]^{2-}$, $[\text{TaF}_6]^-$, $[\text{TaF}_7]^{2-}$, $[\text{Ta}(\text{S}_2\text{C}_6\text{H}_4)_3]^-$, etc. and also gives clusters of $[\text{Ta}_6\text{X}_{12}]^{2+}$ type with halides.

Tungsten, like its 3d and 4d analogues chromium and molybdenum, forms a large number of complexes e.g. $[\text{W}(\text{CO})_6]^{2-}$, $[\text{W}_2(\text{CO})_{10}]^{2-}$, $[\text{W}(\text{CO})_6]$, $[\text{W}_2\text{Cl}_9]^{3-}$, $[\text{W}(\text{CN})_8]^{4+}$, $[\text{WF}_6]^-$, etc.

Rhenium gives various complexes with halides, pyridine and CO in different oxidation states, e.g., $[\text{Re}_2(\text{CO})_{10}]$, $[\text{ReCl}(\text{CO})_5]$, and $[\text{ReCl}_2(\text{Py})_2]$, $[\text{Re}_2\text{Cl}_8]^{2-}$, $[\text{ReF}_8]^{2-}$, $[\text{ReH}_9]^{2-}$, etc.

The complexes of Ir, Pt and Au in different oxidation states with various ligands are given below:

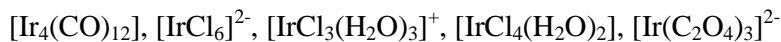

Pt gives complexes in two coordination numbers which are related with the oxidation states, i.e., oxidation state +2, coordination number 4 and oxidation state +4, coordination number 6. For example, $[\text{PtCl}_4]^{2-}$, $[\text{Pt}(\text{NH}_3)_2\text{Cl}_2]$, $[\text{PtCl}_6]^{2-}$, $[\text{Pt}(\text{NH}_3)_4\text{Cl}_2]^{2+}$, etc. Similarly, gold forms complexes such as $\text{K}[\text{Au}(\text{CN})_2]$ (oxidation state +1, coordination number 2), $\text{K}[\text{AuCl}_4]$ (oxidation state +3, coordination number 4), $[\text{AuI}_2(\text{diars})_2]^+$ (oxidation state +4, coordination number 6), etc.

The complex formation in the lower oxidation states by these elements provides an excellent tool for stabilisation of these oxidation states which are otherwise unstable.

3.3.3 Magnetic Properties

As has been discussed earlier, chemical substances may be diamagnetic, paramagnetic or ferromagnetic. Diamagnetism is inherent in every substance irrespective of the presence or absence of the paramagnetism and ferromagnetism. s- and p-block elements always give diamagnetic compounds, the compounds or the ions of ferrous metals, *viz.*, iron, cobalt and nickel have ferromagnetism and there is attraction between these substances and the magnetic field. Ferromagnetic ions are permanently magnetized and are not demagnetized even after their removal from the applied magnetic field. Most of the d-block elements either in the elemental or ionic form (in the compounds/complexes) are paramagnetic and this is due to the presence of unpaired d-electrons in them. The property of paramagnetism, in particular, is expressed in terms of magnetic moment, expressed by the term μ which has the unit of Bohr magneton, B.M. This is related with the number of unpaired electrons, n by the expression:

$$\mu_{\text{eff}} = \sqrt{n(n + 2)} \quad \text{B.M.}$$

Based on this expression the magnetic moments for various substances can be calculated and compared with those obtained experimentally. It is clear that the substance containing the metal ion with the highest number of unpaired electrons will have the maximum magnetic moment.

The above formula of μ has been arrived at by taking into consideration only spin motion of the electrons assuming that in the compounds or complexes of d-block elements, the orbital motion is quenched (or suppressed). If the orbital motion of the electrons is also considered and taken into account, the formula for μ is given as has been mentioned in point 2.3.3 (magnetic properties of second transition series elements).

3.3.4 Formation of coloured Ions/compounds

The analogy given for the elements of first transition series as well as for those of second transition series to exhibit colour also applies to the elements of this series. In solid state or in solution, the compounds or complexes are coloured though only a few such compounds or the complexes are known. The elements of 5d-

transition series which have unpaired electrons only can exhibit colour due to the usual reasons as has been discussed above for 3d- and 4d-transition series elements. The attached atoms (in the compounds) or ligands (in the complexes) are also responsible for the type of colour of the compound because these affect the transition of electron (s) within the subshell or between the subshells. The selection rules for electronic transitions also play an important role in determining the intensity of the colour of the ions/complexes/compounds. If any of the selection rules says that a particular transition is forbidden but it occurs due to the breakdown of the selection rule, the intensity of colour produced is low, i.e., dull. But if the transition is allowed, the intensity of the colour is high, i.e., fast. That is why some compounds are dull coloured but some others have very intense colour.

3.3.5 Catalytic Activity

The elements of third transition series and their compounds also show the catalytic activity, some of them being very important and useful catalysts in a variety of reactions used in industry. Some of the examples in which these elements or their compounds act as catalysts are given below:

- (a) Pt/PtO is used as Radian's catalyst in the oxidation reactions.
- (b) Pt gauze catalyses the oxidation of NH_3 to NO at high temperature and the process is used in the manufacture of nitric acid by Ostwald's process.
- (c) Mixture of Pt and Pd is used as a catalyst in the hydrogenation of unsaturated hydrocarbons.
- (d) Platinised asbestos catalyses the reaction between SO_2 and O_2 in the manufacture of H_2SO_4 by contact process.
- (e) Pt black is used to prepare formaldehyde from methyl alcohol.
- (f) Red hot finely divided Pt is used in the preparation of hydrogen halides from hydrogen and halogens.
- (g) Finely divided Pt is widely used in many hydrogenation and dehydrogenation reactions.
- (h) Large quantities of Pt are also used in petroleum industry, synthetic fiber industry and glass industry.
- (i)

3.3.6 Formation of Interstitial and Non-stoichiometric compounds

The elements of third transition series also form interstitial compounds with small non-metallic elements such as hydrogen, carbon and nitrogen. During the formation of these compounds, there is no change in the lattice structure of the metal because the non-metallic atoms just fit in the voids of metal lattice. Examples are:

TaH_{0.78}, HfC, TaC, WC, W₂C, HgN, TaN, W₂N etc.

Many of these compounds are non-stoichiometric type like TaH_{0.78}, etc. Such compounds have semi-conductivity properties and centres of colours. The non-stoichiometry is, perhaps, due to the defects in the solid structures of transition elements. The apparent molecular formula shows whole number ratio but actually it is not so.

3.3.7 Metallic Character and Alloy Formation

All the elements of this series are metals, most of them hard. Some of them are malleable and ductile (e.g. Au, Pt etc.). All the elements of the series are solids except Hg which among all the d-block elements exists as a liquid at ordinary temperature. These are good conductors of heat and electricity. These elements also crystallise in one of the close lattice structures as has been given for 3d and 4d series elements. Keeping aside Hg, all the metals of the series have high melting points.

In all the three series, it has been observed that the metals of the Groups 8, 9, 10 and 11 (i.e. those of VIII and IB) are softer and more ductile which can be explained in the light of their crystal structure. These metals crystallise to form face centred cubic (fcc) lattice type close packed crystal lattice with large number of planes where deformation can occur, while others crystallise with hexagonal close packed (hcp) or body centred cubic (bcc) lattice type close packed structure. The hardness of the d-block elements indicates the presence of covalent bonding. The number of covalent bonds gives the measure of overall bond-strength and hardness of the metal. Because the unpaired d-electrons can also take part in covalent bond formation and their number increases from Group 3 to 6 $\{(n-1)d^5ns^1\}$. Hence, the metallic lattice becomes stronger and then strength decreases progressively.

These metals also form alloys but only a few alloys have been prepared and used because of the rare nature of these elements, Na-Hg and Al-Hg alloys have been used as reducing agents called amalgams. Pt-Ir alloy is used to prepare coins, standard weights etc. Pt-Ru & Pt-Cu alloys are also important materials. The metals like Pt, Au and Hg are very important, the first two, i.z., Pt and Au are used in jewellery. Gold is also used as coinage metal and in preparing ornamental vessels.

3.3.8 Periodic Properties and their variation along the Series

The periodic properties of the elements of third transition series such as the atomic radii, atomic volumes, ionic radii, melting and boiling points, ionisation energies and reactivity, standard electrode potentials and reducing properties etc. vary along the series (period) from the first element to the last one. For some properties the variation is regular and for the other it is irregular particularly at the end of the series.

(a) Atomic Radii, Atomic Volumes and Ionic Radii

The values of atomic radii for these elements have been found to decrease from La to Os, the element in the middle and then have increasing tendency up to the last element, Hg. The values are very close from W to Pt because, perhaps, of the increased screening effect of the 5d-electrons which neutralises the nuclear pull exerted on the 6s- electrons. Then the screening effect becomes more effective in the later elements that too are still more pronounced in the last element, Hg which has atomic radius only less than that of La and more than that of any element of the series. This trend has been shown below:

Elements	La	Hf	Ta	W	Re	Os	Ir	Pt	Au	Hg
Atomic radius(pm)	169	144	134	130	128	126	127	130	136	150

The atomic volumes of the elements also have the similar trend as is found for the atomic radii. The values first decrease in the series up to the middle and then increase till the last element. Atomic volumes for various elements of the series are being given below:

Elements	La	Hf	Ta	W	Re	Os	Ir	Pt	Au	Hg
Atomic volume(cm ³)	22.50	13.60	10.90	9.52	8.85	8.44	8.54	9.10	10.22	14.80

The ionic radii follow almost the same trend as the atomic radii for most of the elements. Ionic radii of the elements have been obtained in different oxidation states and the trend along the series can only be established for the ions having the same oxidation state. Some values have been given below:

Metal ion	La ³⁺	Hf ⁴⁺	Ta ⁵⁺	W ⁴⁺	Re ⁵⁺	Os ⁴⁺	Ir ³⁺	Pt ⁴⁺	Au ³⁺	Hg ²⁺
Ionic radius (pm)	117	85	70	80	72	77	82	77	85	106

It has been observed that the ionic radii of the cations of different elements in the same oxidation state generally decrease with the increasing nuclear charge or the atomic number. The ionic radii of the elements of third transition series are almost the same as those of the corresponding cations derived from the elements of second transition series. The similarity in their ionic radii is due to the presence of fourteen lanthanides between La and Hf.

(b) Melting and Boiling Points

The melting and boiling points of these elements are very high except for Hg, a liquid in physical state with very low melting or freezing point (-38.4⁰C). For these elements, the values have been listed below:

Element	La	Hf	Ta	W	Re	Os	Ir	Pt	Au	Hg
Melting point (⁰ C)	920	2222	2996	3410	3180	2700	2454	1769	1063	-38.4

From the list, it is clear that Hf, Ta, W, Re, Os, and Ir have very high melting points in comparison to La, Pt, Au & ofcourse Hg. The boiling points of all these elements are above 3000⁰C leaving aside Hg which has low boiling point of 357⁰C.

(c) Ionization Energies and Reactivity

The first ionization energy values of these elements increase gradually as we move from left to right in the series from La to Hg. The values in kJ/mole have been given below:

Elements	La	Hf	Ta	W	Re	Os	Ir	Pt	Au	Hg
First ionization energy (kJ/mole)	538	684	761	770	760	840	880	870	890	1008

If compared with the first ionization energies of the elements of second transition series, it can be observed that Y has higher value than La (both elements are the members of Group 3) due to its smaller size. From Hf to Hg, these elements have higher values of first ionisation energies than those of the elements of second transition series. This is attributed to the increased nuclear charge in the elements of this series though the atomic sizes of the elements of both the series, *viz.* 4d and 5d series do not vary much. Thus, higher nuclear charge causes strong inward pull on the outer electrons which are therefore, strongly held with the nuclei and their removal becomes difficult. This ultimately results in the higher values of first ionization energies for these elements. Hg has exceptionally high value of first ionization energy because more energy is required to remove an electron from the stable $5d^{10}6s^2$ configuration of this element.

Due to high ionization energies and other factors discussed in section 1.3 above, these elements show low reactivity, such that some of these elements, *viz.* Ir, Pt, Au, etc. are known as noble metals due to their passive nature towards the chemical reactions with other elements and reagents.

(d) Standard Electrode Potentials and Reducing Properties

The two terms, i.e., standard electrode potentials (reduction) and the reducing properties of the elements are intimately related with each other.

For 3d- and 4d-transition series elements some examples have been given earlier and it has been stated that metals with negative values of standard electrode potential as compared to standard hydrogen electrode, for which E^0 value is taken as zero, act as reducing agents. Such metals can displace hydrogen gas from dilute acids

as well as other metals from their solutions. But there are metals, particularly some d-block elements, which have positive values of standard electrode (reduction) potentials with the tendency to get reduced by H₂ itself or the metals with negative standard electrode potential values. Cu and Ag are such metals belonging to 3d- and 4d-transition series. Among the 5d-transition series elements, Pt, Au and Hg provide the excellent examples of such metals as is given below:

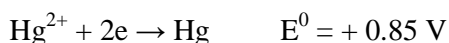

These metals may thus, act as oxidising agents and have a tendency to take up the electrons. They hardly provide electrons for reduction.

3.4 COMPARATIVE STUDY OF THE ELEMENTS OF THIRD TRANSITION SERIES AND THE FIRST TRANSITION SERIES

(a) Oxidation states

It has been observed that the elements of both these transition series exhibit variable oxidation states including both common and uncommon. As has been stated earlier that lower oxidation states are most stable and their chemistry is more pronounced for the elements of first transition (3d) series while their higher oxidation state are less stable. That is why their compounds in the higher oxidation states are more reactive and less stable. This fact can be exemplified by taking the strong oxidising nature of dichromate ($\text{Cr}_2\text{O}_7^{2-}$, oxidation state of Cr = +6) and permanganate (MnO_4^- , oxidation state of Mn = +7) ions. These ions under suitable conditions take part in redox reactions and get reduced to Cr(III) and Mn(II) states which are stable.

Lower oxidation states are of relatively little importance for most of the elements of third transition series. The Ir^{2+} ion (5d) is hardly known but its 3d analogue, Co^{2+} is quite stable in aqueous medium. Similarly, Ir^{3+} ion does not form

complex with NH_3 molecule while $[\text{Co}(\text{NH}_3)_6]^{3+}$ is highly stable in aqueous medium. In manganese group (Group 7), Mn^{2+} ion (3d) is stable; Re^{2+} ion (5d) is unstable and occurs only in some complexes with π -ligands and metal clusters. Similarly, Cr^{3+} ion (3d-transition series) forms a large number of complexes and other normal compounds, W^{3+} ion (5d-transition series) forms only a few complexes.

The higher oxidation state is generally more stable for the elements of third transition series than that for the elements of first transition series. For example OsO_4 , WCl_6 , PtF_6 , etc. are quite stable while FeO_4 , CrCl_6 , NiF_6 , etc. are not known. Also WO_4^{2-} ion is highly stable and is not reduced easily whereas CrO_4^{2-} is strong oxidising agent and is readily reduced to +3 states. Similarly, MnO_4^- is strong oxidising agent but ReO_4^- is stable and very weak oxidising agent.

The highest oxidation state for 5d-transition series elements is +8 in OsO_4 while that for 3d-transition series elements is +7 in MnO_4^- ions.

(b) Ionic Radii

It has been observed that the ionic radii of 3d-series elements are smaller than those of the 5d-series elements but there is only a small difference between the radii of the ions of 4d- and 5d-series elements. Thus $3d < 4d < 5d$. This has been shown below in the comparative table of the ionic radii of the elements of the two series.

Ions:	Sc^{3+}	Ti^{4+}	Cr^{4+}	Zn^{2+}
Radii (pm):	81	75	68	74
Ions:	La^{3+}	Hf^{4+}	W^{4+}	Hg^{2+}
Radii (pm):	117	85	80	106

The change in the values after lanthanides is small because of the lanthanide contraction.

(c) Magnetic Behaviour

As has been mentioned earlier that the magnetic properties of the elements of first transition series could be interpreted easily and the magnetic moments of their

ions/atoms or compounds can be represented by the spin only formula. The calculated magnetic moment in this way gives an idea of the number of unpaired electrons in them as well as the type of geometry of the complexes of these metals can be predicted.

It has been observed that the magnetic behaviour of the elements of third transition series is more complex and difficult to explain by using the spin only formula. Thus, the magnetic moment from the number of unpaired electrons is difficult to find out in the compounds or complexes of these elements. This is because 5d orbitals are too much diffused or spread out in space and hence, the inter electronic repulsions in these are much less in comparison to 3d orbitals (of the elements of first transition series) Hence, a given set of ligands produces very large crystal field splitting energies in 5d orbitals than in 3d orbitals. The heavier elements of this series will, therefore, tend to give inner orbital or low spin complexes as compared to those of first transition series which generally form outer orbital or high spin complexes.

3.5 SPECTRAL PROPERTIES AND STEREOCHEMISTRY OF THIRD TRANSITION SERIES ELEMENTS

Most of the compounds/complexes of transition metals are highly coloured because the metal ions are capable of absorbing radiant energy in the visible region of the electromagnetic spectrum causing d-d transition.

As has been discussed in Unit 1 and 2, the d-d transitions (i.e., electronic transition between two sets of d-orbitals) are responsible for the electronic spectra and colour of the ions/compounds/complexes of transition metals. But, this transition only occurs when the radiation or photon of correct energy interacts with the compound/complex having energy difference between two d-orbital sets of central metal ion equal to that associated with the photon. This type of transition is called d-d transition and the colours exhibited by the compounds/complexes of the elements of first transition series are due mainly to these transitions.

It has been observed that the d-d transitions (electronic spectra) of the compounds/complexes of third transition (5d-) series elements are less important than those of the complexes of first transition series elements because more energy is

required for causing d-d transitions due to greater value of Δ , the crystal field splitting energy. In the octahedral ligand field the increasing Δ_0 is as follows: $\text{Ir}^{3+} < \text{Re}^{4+} < \text{Pt}^{4+}$, etc.

The other types of electronic transitions which are encountered in the complexes of the third transition series elements and responsible for their colours are mainly the charge transfer spectra (C.T.) in which electronic transition occurs from metal to ligand or ligand to metal preferably the latter. Sometimes M-M transition is also observed in some polynuclear complexes. In the compounds/complexes of heavier elements of 5d-series, because of the larger magnitude of Δ (crystal field splitting energy), the d-d bands are found at lower wavelengths or higher frequency and hence, overlap with the charge transfer bands. The charge transfer implies the transfer of electron from one atom to another, i.e. from metal to ligand atom or from ligand atom to metal within the complex/compound and thus reflect the internal redox tendencies of both the central metal atoms/ions and ligands. Thus, it is possible to classify and rank metal ions according to their oxidising power:

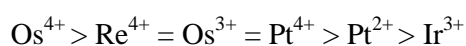

Greater the oxidising power of the metal ion and also greater the reducing power of the ligand, lower the energy at which the charge transfer (L→M) bands appear.

The compounds with M-M bonds also give intense colour, e.g., $[\text{Re}_2\text{Cl}_8]^{2-}$ is royal blue. The metal carbonyls of these elements with M-M bonds are often intensely coloured.

Because the d-d transitions may be spin forbidden as well as are Laporte forbidden, the breakdown of the selection rules gives light colours to the complexes. But charge transfer transitions give rise to strong absorptions and when these transitions occur in visible region, the complex/compound shows intense colour, This is because the C.T. transitions are both spin and Laporte allowed.

Stereochemistry of the complexes and compounds

It is easier to summarize the stereochemistry of the compounds and complexes of the elements of this series group wise. Depending on the oxidation state, coordination number and type of ligands present in the complexes or the atoms in the compounds, the elements show different stereochemistries. The stereochemistry of hafnium though less explored (Group 4 element) is tabulated here Table. 3.1.

Table 3.1: Oxidation states

Oxidation state	Coordination number	Geometry	Examples
0	6	Octahedral	$[(\text{arene})_2\text{HfPMe}_3]$
3+	6	Octahedral	$[\text{HfI}_3]$
4+	6	Octahedral	$[\text{HfF}_6]^{2-}$, $[\text{Hf}(\text{acac})_4]$, $[\text{Hf}(\text{C}_2\text{O}_4)_4]^{4-}$
		Pentagonal bipyramidal	$[\text{HfF}_7]^{3-}$
		Monoclinic	$[\text{HfO}_2]$

The stereochemistry of tantalum (Group 5 element) in different oxidation states is summarized in Table 3.2.

Table 3.2 Oxidation states and stereochemistries of tantalum compounds

Oxidation state	Coordination number	Geometry	Examples
-3	5	Trigonal bipyramidal	$[\text{Ta}(\text{CO})_5]^{3-}$
-1	6	Octahedral	$[\text{Ta}(\text{CO})_6]^-$
+3	6	Octahedral	$[\text{Ta}_2\text{Cl}_6(\text{SMe}_2)_3]$
+4	6	Octahedral	$[\text{TaCl}_4\text{py}_2]$, $[\text{TaCl}_6]^{2-}$
	8	Square antiprism	$[\text{Ta}_2\text{Cl}_8(\text{PMe}_3)_4]$

+5	5	Trigonal bipyramidal	TaCl ₅
	6	Octahedral	[TaO ₃] ⁻ , [Ta ₂ Cl ₁₀], [TaCl ₆] ⁻
	8	Square antiprism	[TaF ₈] ³⁻

The stereochemistry of tungsten (group 6 element in different oxidation states) is tabulated below: Table. 3.3.

Table 3.3 Oxidation states and stereochemistries of tungsten compounds

Oxidation state	Coordination number	Geometry	Examples
0	6	Octahedral	[W(CO) ₆]
+3	6	Octahedral	[W(diars)(CO) ₃ Br ₂] ⁺
+4	6	Octahedral	[WBr ₄ Me ₂]
	8	Dodecahedral	[W(CN) ₈] ⁴⁻
+5	6	Octahedral	[WF ₆] ⁻
	8	Dodecahedral	[W(CN) ₈] ³⁻
+6	4	Tetrahedral	[WO ₄] ²⁻
	6	Octahedral	[WCl ₆]
	8	Dodecahedral	[WF ₈] ²⁻

Stereochemistry of rhenium (Group 7 element) in different oxidation states is more pronounced than its 4d congener Tc which has been tabulated below in Table.3.4.

Table 3.4 Oxidation states and stereochemistries of rhenium compounds

Oxidation state	Coordination number	Geometry	Examples
0	6	Octahedral	[Re ₂ (CO) ₁₀]

+1	5	Trigonal bipyramidal	$[\text{ReCl}(\text{CO})_2(\text{PPh}_3)_2]$
	6	Octahedral	$[\text{Re}(\text{CO})_5\text{Cl}]$, $[\text{Re}(\text{CN})_6]^{5-}$
+2	6	Octahedral	$[\text{ReCl}(\text{N}_2)(\text{PR}_3)_4]^+$, $[\text{Re}(\text{bipy})_3]^{2+}$
+3	6	Octahedral	$[\text{ReCl}_2(\text{acac})(\text{PPh}_3)_2]$
	7	Pentagonal bipyramidal	$[\text{Re}(\text{CN})_7]^{4-}$
+4	6	Octahedral	$[\text{ReX}_6]^{2-}$, $[\text{Re}_2\text{OCl}_{10}]^{4-}$
+5	5	Trigonal bipyramidal	ReCl_5 , ReF_5
	6	Octahedral	$[\text{ReOCl}_3(\text{PPh}_3)_2]$, $[\text{ReOCl}_5]^{2-}$
	8	Dodecahedral	$[\text{Re}(\text{diars})_2\text{Cl}_4]^+$
+6	4	Tetrahedral (distort.)	$[\text{ReO}_4]^{2-}$
	5	Square pyramidal	$[\text{ReOCl}_4]$
	6	Octahedral	$[\text{ReF}_6]^-$, $[\text{Re}(\text{CH}_3)_6]^-$
	8	Square antiprism	$[\text{ReF}_8]^{2-}$
+7	4	Tetrahedral	$[\text{ReO}_4]^-$, $[\text{ReOCl}_3]$
	7	Pentagonal bipyramidal	$[\text{ReF}_7]$
	9	Tricapped trigonal prismatic	$[\text{ReH}_9]^{2-}$

Stereochemistry of osmium (Group 8 element) in various oxidation states is being given in Table 3.5.

Table 3.5 Oxidation states and stereochemistries of osmium compounds

Oxidation state	Coordination number	Geometry	Examples
0	5	Trigonal bipyramidal	$[\text{Os}(\text{CO})_5]$, $[\text{Os}(\text{CO})_4 \text{X}]_2$
+2	6	Octahedral	$[\text{Os}(\text{CN})_6]^{4-}$
+3	6	Octahedral	$[\text{OsCl}_6]^{3-}$, $[\text{Os}(\text{dipy})_3]^{3+}$
+4	4	tetrahedral	$[\text{OsPh}_4]$
	6	Octahedral	$\text{K}_2[\text{OsCl}_6]$
	7	Distorted pentagonal bipyramidal	$[\text{OsH}_3(\text{PPh}_3)_4]^+$
+5	6	Octahedral	$\text{Na}[\text{OsF}_6]$
+6	5	Square pyramidal	$[\text{OsOCl}_4]$
	6	Octahedral	$[\text{OsF}_6]$, $[\text{OsO}_2\text{Cl}_4]^{2-}$, $[\text{OsO}_2(\text{OH})_4]^{2-}$
+7	4	Tetrahedral	$[\text{OsO}_4]^-$
	6	Octahedral	$[\text{OsOF}_5]$
+8	4	Tetrahedral	$[\text{OsO}_4]$
	6	Octahedral	$[\text{OsO}_3\text{F}_3]^-$, $[\text{OsO}_4(\text{OH})_2]^{2-}$

Stereochemistry of iridium (Group 9 element) in various oxidation states has been summarized in Table 3.6.

Table 3.6 Oxidation states and stereochemistries of iridium compounds

Oxidation state	Coordination number	Geometry	Examples
-1	4	Tetrahedral	$[\text{Ir}(\text{CO})_3\text{PPh}_3]^-$
+1	4	Planar	$[\text{IrCl}(\text{CO})(\text{PR}_3)_2]$

	5	Trigonal bipyramidal	[HIr(CO)(PPh ₃) ₃]
+3	5	Trigonal bipyramidal	[IrH ₃ (PR ₃) ₂]
	6	Octahedral	[IrH ₃ (PPh ₃) ₃], [IrCl ₆] ³⁻
+4	6	Octahedral	[IrCl ₆] ²⁻ , [Ir(C ₂ O ₄) ₃] ²⁻
+5	6	Octahedral	Cs[IrF ₆]
+6	6	Octahedral	[IrF ₆]

The stereochemistry of platinum (Group 10 element) in different oxidation states is being given in Table 3.7.

Table 3.7 Oxidation states and stereochemistries of some platinum compounds

Oxidation state	Coordination number	Geometry	Examples
0	4	Tetrahedral	[Pt(CO)(PPh ₃) ₃]
+2	4	Square planar	[PtCl ₄] ²⁻
	6	Octahedral	[Pt(NO)Cl ₅] ²⁻
+4	6	Octahedral	[Pt(en) ₂ Cl ₂] ²⁺ , [Pt(NH ₃) ₆] ⁴⁺ , [PtCl ₆] ²⁻
+5	6	Octahedral	[PtF ₆] ⁻
+6	6	Octahedral	[PtF ₆]

The stereochemistry of gold (element of Group 11) is being given in Table 3.8.

Table 3.8 Oxidation states and stereochemistries of some gold compounds

Oxidation state	Coordination number	Geometry	Examples
+1	2	Linear	$[\text{Au}(\text{CN})_2]^-$
	3	Trigonal planar	$[\text{AuCl}(\text{PPh}_3)_2]$
	4	Tetrahedral	$[\text{Au}(\text{diars})_2]^+$
+3	4	Planar	$[\text{AuBr}_4]^-$, $[\text{AuPh}_4]^-$
	5	Trigonal bipyramidal	$[\text{Au}(\text{diars})_2\text{I}]^{2+}$
	6	Octahedral	$[\text{AuBr}_6]^{3-}$,

3.6 SUMMARY

In this unit, you have studied the general characteristics of the elements of third transition series, viz., electronic configuration and variable oxidation states, magnetic behaviour, complex formation tendency, formation of coloured compounds/complexes, catalytic activity, metallic character and alloy formation, formation of interstitial and non-stoichiometric compounds along with the periodic properties such as atomic and ionic radii, melting and boiling points, ionisation energy and reactivity, standard electrode (reduction) potential and reducing properties etc with their variation along the transition series. Effort has also been made to record a comparative account of these elements with their 3d- analogues in respect to their ionic radii, oxidation states and magnetic behaviour. The spectral properties and stereochemistry of the elements in the form of tables have also been given to make it easy to understand the subject.

3.7 TERMINAL QUESTIONS

- Write down the names and symbols of the elements of third transition series.
- The maximum oxidation state of osmium is

(a) 4

- (b) 6
(c) 8
(d) 10
3. The oxidation state of tungsten in $[\text{WCl}_6]$ is
(a) + 2
(b) + 4
(c) + 5
(d) + 6
4. The formation of coloured compounds/complexes by the elements of 5d-transition series is due to
(a) d-d transitions
(b) Charge transfer transitions
(c) Transitions in UV region
(d) None of above
5. The atomic radii of second and third transition series elements are close to one another. True/false
6. Write down two catalytic applications of Pt.

3.8 ANSWERS

1. Please see the text
2. c
3. d
4. b
5. True
6. Please see the text.

UNIT-4 CHEMISTRY OF THE LANTHANIDE ELEMENTS

CONTENTS:

- 4.1 Introduction
- 4.2 Objectives
- 4.3 Electronic structure
- 4.4 Oxidation states and ionic radii
- 4.5 Lanthanide contraction
- 4.6 Complex formation
- 4.7 Occurrence and isolation
- 4.8 Lanthanide compounds
- 4.9 Summary
- 4.10 Terminal Question
- 4.11 Answers

4.1 OBJECTIVES

The objectives of this unit are to make the learners understand various aspects regarding lanthanides or 4f-block elements such as their electronic structure or configuration, oxidation states, ionic radii and corresponding lanthanide contraction, complex formation by these elements, etc. It is also aimed at giving the readers an idea of the occurrence and isolation of these elements along with the discussion of the lanthanide compounds.

4.2 INTRODUCTION

Lanthanides, also sometimes called lanthanons, are the elements which constitute a distinct series of fourteen elements from cerium (Ce, $Z = 58$) to lutetium (Lu, $Z = 71$). They are so called because these elements succeed lanthanum (La, $Z = 57$), the element of Group 3 and lie between it and hafnium (Hf, $Z = 72$), the element of Group 4, both belonging to third transition series (or 5d-transition series). That is why they are also known as inner transition elements. These fourteen elements belong to f-block and are the members of 4f-series because the last or differentiating electron in the atoms of these elements enters 4f-subshell, i.e., the f-

subshell of ante-penultimate shell (here $n=6$). Thus, f-block elements have partly filled f-subshells of $(n-2)^{\text{th}}$ shell in the elementary or ionic state.

The first and the last elements of the 4f-series have been mentioned above (i.e., Ce and Lu). The rest twelve elements along with their symbols and atomic numbers are given below:

praseodymium (Pr, $Z = 59$), neodymium (Nd, $Z = 60$), promethium (Pm, $Z = 61$), samarium (Sm, $Z = 62$), europium (Eu, $Z = 63$), gadolinium (Gd, $Z = 64$), terbium (Tb, $Z = 65$), dysprosium (Dy, $Z = 66$), holmium (Ho, $Z = 67$), erbium (Er, $Z = 68$), thulium (Tm, $Z = 69$) and ytterbium (Yb, $Z = 70$). In analogy with various series of d-block elements, these elements are called first inner transition series elements. All the fourteen elements of the series resemble closely in their electronic configuration and chemical properties with one another as well as with lanthanum which may be called a prototype of lanthanide elements. All these elements said to be the members of Group 3 i.e., Sc group and have been allotted one single position in the periodic table.

These elements were originally called rare earth elements because the elements then known occurred as oxides (earths) and were available scarcely. All the elements have similar physical and chemical properties hence are considered together for their study.

It is interesting to note that the elements with even atomic numbers are relatively more abundant and also have a larger number of isotopes but those with odd atomic numbers are less abundant and do not have more than two isotopes. Promethium ($Z = 61$) has been made artificially only and does not occur in nature.

4.3 ELECTRONIC STRUCTURE OF LANTHANIDES

The electronic configurations of the lanthanides have been derived from the electronic spectra of the atoms of these elements. These spectra have great complexity thereby inferring to some doubt about the configurations. In the following table, the expected and alternative probable configurations of the elements have been listed. The expected configurations have been derived by taking into account the electronic configuration of lanthanum and supposing that in all the lanthanide elements succeeding lanthanum, additional electrons are filled in 4f-subshell

successively from cerium to lutetium. Thus the 4f-electrons are embedded in the interior while 5d and 6s electrons are exposed to the surroundings. The electronic configurations of lanthanide elements are given in Table 4.1.

Table 4.1 Electronic structures of lanthanum and lanthanides

Element	At. number (Z)	Expected electronic configuration	Alternative probable configuration
Lanthanum (La)	57	[Xe]5d ¹ 6s ²	-
Cerium (Ce)	58	[Xe]4f ¹ 5d ¹ 6s ²	[Xe]4f ² 6s ²
Praseodymium (Pr)	59	[Xe]4f ² 5d ¹ 6s ²	[Xe]4f ³ 6s ²
Neodymium (Nd)	60	[Xe]4f ³ 5d ¹ 6s ²	[Xe]4f ⁴ 6s ²
Promethium (Pm)	61	[Xe]4f ⁴ 5d ¹ 6s ²	[Xe]4f ⁵ 6s ²
Samarium (Sm)	62	[Xe]4f ⁵ 5d ¹ 6s ²	[Xe]4f ⁶ 6s ²
Europium (Eu)	63	[Xe]4f ⁶ 5d ¹ 6s ²	[Xe]4f ⁷ 6s ²
Gadolinium (Gd)	64	[Xe]4f ⁷ 5d ¹ 6s ²	[Xe]4f ⁷ 5d ¹ 6s ²
Terbium (Tb)	65	[Xe]4f ⁸ 5d ¹ 6s ²	[Xe]4f ⁹ 6s ²
Dysprosium (Dy)	66	[Xe]4f ⁹ 5d ¹ 6s ²	[Xe]4f ¹⁰ 6s ²
Holmium (Ho)	67	[Xe]4f ¹⁰ 5d ¹ 6s ²	[Xe]4f ¹¹ 6s ²
Erbium (Er)	68	[Xe]4f ¹¹ 5d ¹ 6s ²	[Xe]4f ¹² 6s ²
Thulium (Tm)	69	[Xe]4f ¹² 5d ¹ 6s ²	[Xe]4f ¹³ 6s ²
Ytterbium (Yb)	70	[Xe]4f ¹³ 5d ¹ 6s ²	[Xe]4f ¹⁴ 6s ²
Lutetium (Lu)	71	[Xe]4f ¹⁴ 5d ¹ 6s ²	[Xe]4f ¹⁴ 5d ¹ 6s ²

According to the latter view, as is evident from the table, the solitary 5d-electron shifts into the 4f-subshell in all the cases except in Gd (64) and Lu (71) because it is favourable energetically to move the single 5d-electron into 4f-orbital in most of the elements and give more appropriate electronic configuration which is widely accepted. In Gd such a shift would have destroyed the symmetry of a half filled f-subshell and the resulting configuration would have been less stable than the probable configuration i.e., $4f^7$ is more stable than $4f^8$ configuration. In lutetium, the f-subshell is already completely filled and cannot accommodate any additional electron.

From the above, it may be concluded that the general electronic configuration of lanthanide elements could be written as $[Xe](n-2)f^{1-14}(n-1)d^{0,1}ns^2$ where n is the principal quantum number, i.e., 6. The three subshells, viz., (n-2)f, (n-1)d and ns together form the valence shell of these elements, i.e., 4f.5d.6s = valence shell.

4.4 OXIDATION STATES

It has been shown that the lanthanide elements are highly electropositive and form essentially ionic compounds. It is observed for these elements that +3 (i.e. formation of tripositive ions, Ln^{3+}) is the principal or common oxidation state exhibited by all of them. This is said to be the most stable oxidation state of the lanthanides. Some of these elements also show +2 and +4 oxidation states but except a few such ions, they have the tendency to get converted to +3 state. For example, Sm and Ce form Sm^{2+} and Ce^{4+} ions but are easily converted to +3 states. That is why Sm^{2+} is a good reducing agent while Ce^{4+} is a good oxidising agent, i.e.,

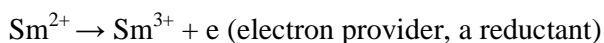

It means Ln^{2+} and Ln^{4+} ions are less frequent than Ln^{3+} ions among the lanthanides. +2 and +4 oxidation states are shown by the elements particularly when they lead to:

- (a) Noble gas electronic configuration, e.g., Ce^{4+} ($4f^0$),
- (b) Half-filled f-orbital, e.g., Eu^{2+} and Tb^{4+} ($4f^7$), and
- (c) Completely filled f-orbital, e.g., Yb^{2+} ($4f^{14}$) in the valence shell.

Among the above, +2 and +4 oxidation states, which exist only in aqueous solutions, are exemplified by Sm^{2+} , Eu^{2+} , Yb^{2+} and Ce^{4+} .

There are some exceptions also, i.e., sometimes +2 and +4 oxidation states are also shown by the elements which are close to f^0 , f^7 and f^{14} states, e.g., the valence shell configurations of the ions given below are $4f^1$, $4f^2$, $4f^3$, $4f^6$ and $4f^8$, etc.:

Ce^{3+} : $4f^1$; Ce^{2+} : $4f^2$; Sm^{2+} : $4f^6$; Pr^{4+} : $4f^1$; Pr^{3+} : $4f^2$; Dy^{2+} : $4f^8$; Nd^{4+} : $4f^2$; Tm^{2+} : $4f^{13}$.

No satisfactory explanation for these exceptions has yet been given. These oxidation states have only been explained on the basis of thermodynamic and kinetic factors, that too arbitrarily. Due to the only one stable oxidation state (i.e., +3), lanthanide elements resemble each other much more than do the transition (or d-block) elements. It has also been observed that the higher oxidation states of the lanthanides are stabilized by fluoride or oxide ions, while the lower oxidation states are favoured by bromide or iodide ions. Among the lanthanides, in addition to +3 states, +2 states is shown by Nd, Sm, Eu, Tm, and Yb only whereas +4 state is exhibited by Ce, Pr, Nd, Tb and Dy elements. Rest five elements show only +3 states.

4.5 IONIC RADII AND LANTHANIDE CONTRACTION

Here, ionic radii of tripositive ions (i.e., Ln^{3+}) have only been considered because +3 is the most stable and common oxidation state of all the lanthanides, in general. It has been observed that the atomic as well as the ionic radii of lanthanides decrease steadily as we move from Ce to Lu. The ionic radii have been listed below (for Ln^{3+} ions):

Ln^{3+} ions	Ce^{3+}	Pr^{3+}	Nd^{3+}	Pm^{3+}	Sm^{3+}	Eu^{3+}	Gd^{3+}	Tb^{3+}	Dy^{3+}	Ho^{3+}	Er^{3+}	Tm^{3+}	Yb^{3+}	Lu^{3+}
Ionic radii (pm)	103	101	100	98	96	95	94	92	91	90	89	88	86	85

From the above list it is clear that the ionic radii decrease steadily all along the series amounting in all to 18 pm. This shrinking in the ionic size of the Ln^{3+} ions with increasing atomic number is called **lanthanide contraction**. The term steadily

decrease means the values decrease regularly and with a very small difference though the nuclear charge increases by +14 units from the first to the last element.

The atomic radii of these elements also decrease from Ce to Lu (Ce : 165 pm, Lu : 156 pm) but the overall shift is only of $165-156 = 9$ pm. These values do not decrease regularly like ionic radii rather there are some irregularities at Eu and Yb which have abnormally high atomic radii. (Eu : 185 pm, Yb : 170 pm).

The atomic radii for the metals are actually the metallic radii which are recorded for the metal atoms surrounded by 8 or 12 nearest neighbors (in bulk). Various metal atoms in metal crystal are bonded together by metallic bonding. In Eu and Yb, only two 6s-electrons participate in metallic bonding, 4f-subshells being stable. For other lanthanides, three electrons are generally available for this purpose. This results in larger atomic volumes for Eu and Yb because of weaker bonding among atoms. The larger values ultimately give rise to the larger size to the atoms of the elements.

Cause of Lanthanide Contraction

As we move along the lanthanide series from Ce to Lu, the addition of electrons takes place to the 4f-orbitals, one at each step. The mutual shielding effect of f-electrons is very little, being even smaller than that of d-electrons, due to the scattered or diffused shape of these orbitals. However, the nuclear charge (i.e. atomic number) goes on increasing by one unit at each step (i.e., each next element). Thus, the attraction between the nucleus and the outermost shell electrons also goes on increasing gradually at each step. The 4f-electrons are not able to shield effectively the attraction of the nucleus (i.e. inward pull) for the electrons in the outer most shell as the atomic number of lanthanide elements increases. This results in the increased inward pull of the outer most electrons by the nucleus, finally causing the reduction in the atomic or ionic size of these elements. The sum of the successive reductions gives the total lanthanide contraction.

It may be concluded that the lanthanide contraction among the 4f-series elements and their ions takes place due to the poor shielding effect of 4f-electrons and gradual increase in the nuclear charge.

Consequences of Lanthanide Contraction

Lanthanide contraction plays an important role in determining the chemistry of lanthanides and heavier transition series elements. Some important consequences of lanthanide contraction are discussed below:

(a) Basic character of lanthanide hydroxides, $\text{Ln}(\text{OH})_3$

Because the size of tripositive lanthanide ions (Ln^{3+}) decreases regularly with increasing atomic number (or nuclear charge), the process being called lanthanide contraction, therefore, the covalent character between Ln^{3+} ion and OH^- ions increases from $\text{La}(\text{OH})_3$ to $\text{Lu}(\text{OH})_3$ (Fajans' rules). As a result, the basic character of the hydroxides decreases with increasing atomic number. Consequently, $\text{La}(\text{OH})_3$ is the most basic while $\text{Lu}(\text{OH})_3$ is the least basic.

(b) Resemblance between the atomic radii of the second and third transition series elements

The lanthanide contraction is an important factor in allowing the separation of lanthanides from one another. Also it has significant effect on the relative properties of the elements which precede and succeed the lanthanides. Normally in the same group, the atomic (or covalent) radii increase as the value of n (principal quantum number) increases due to increased distance between the nucleus and the outermost shell of the electrons which counterbalances the increased nuclear charge. This fact is evident when the values of atomic radii are compared for the elements of first and second transition series. On the same analogy, the atomic radii of the elements of third transition series should be greater than those of the second transition series elements. This statement is valid only for the elements of Group 3, i.e. Sc, Y and La in terms of their atomic radii (see the table given below). But, when these values are compared for the elements of 4d and 5d series in the next group, viz. Group 4, 512, it is observed that the values are unexpectedly almost equal. The similarity in the values of atomic radii for the elements of second and third transition series is attributed to the inclusion of 14 lanthanides between La ($Z = 57$, Group 3) and Hf ($Z = 72$, Group 4) of third transition series which due to "lanthanide contraction" cancel the increase in the values of atomic radii. Due to the similarity in the size of the elements of the two series (i.e., second and third), the elements of a particular Group resemble each other more closely in their properties than do the

elements of first and second transition series. The examples of the pairs of elements which show similar properties and hence are difficult to separate are Zr- Hf, Nb-Ta, Mo-W, Ru-Os, Rh-Ir, Pd-Pt and Ag-Au. The atomic radii of the elements of the three transition series are given below to justify the above statement.

Groups	3	4	5	6	7	8	9	10	11	12
Elements of 3d-series	Sc	Ti	V	Cr	Mn	Fe	Co	Ni	Cu	Zn
Atomic radii (pm)	144	132	122	117	117	117	116	115	117	125
Elements of 4d-series	Y	Zr	Nb	Mo	Tc	Ru	Rh	Pd	Ag	Cd
Atomic radii (pm)	162	145	134	130	127	125	125	128	134	148
Elements of 5d-series	La-Ln Hf		Ta	W	Re	Os	Ir	Pt	Au	Hg
Atomic radii (pm)	169	144	134	130	128	126	127	130	136	150

From this table, it is evident that due to lanthanide contraction, the atomic and ionic radii of second and third transition series elements do not differ much though they are appreciably higher than those of first transition series elements. It is also observed that the atomic radii of the elements falling immediately after the lanthanide series are closer to those of their 4d-congeners and the effect slowly decreases along the series of 5d-elements as we move away from it.

(a) Densities of the elements of the three transition series

The density and atomic volume are inversely proportional to each other. All the transition metals have low values for their atomic volumes and hence their densities are high. In a given transition series, the atomic volumes of the elements first decrease on proceeding from left to right and generally attain a minimum value for the elements of group VIII (i.e., Groups 8,9,10). They then start increasing further up to Group 12 elements. Accordingly, the

density of the elements increases from left to right up to the elements of Group VIII (Groups 8,9,10) and then decreases up to Group 12.

Down the group, the densities of the elements increase regularly. But the striking feature that has been observed on moving from the first element to the last element in every group is that the densities of the elements belonging to second transition series are only slightly higher than those of the corresponding elements of 3d-series while the values for the elements from Hf ($Z = 72$) to Hg ($Z = 80$) (i.e., 5d-series) are almost double of those for the elements from Zr ($Z=40$) to Cd ($Z=48$), respectively (4d-series). This analogy does not apply to Y ($Z=39$) and La ($Z=57$). This can be explained as follows:

Because of lanthanide contraction, the atomic sizes of the elements of third transition series after La ($Z=57$) i.e. from Hf onwards become very small and as a result, the packing of atoms in their metallic crystals becomes much compact which results in high densities. Also, there is only a small difference in the atomic sizes of the elements of the two series, viz., 4d-and 5d-series but the atomic masses of the elements of 5d-series are almost double to the corresponding elements of 4d-series. This makes the densities of 5d-series elements almost double to those of the elements of 4d-series.

(b) Similarities among lanthanides

There is very small change in the radii of lanthanides and hence their chemical properties are quite similar. This makes the separation of these elements using the usual physical and chemical methods difficult. Consequently new methods like ion exchange technique, solvent extraction etc. have now been used for their separation which are based on slight difference in the properties like hydration, complex ion formation, etc.

4.6 COMPLEX FORMATION BY LANTHANIDES

The lanthanides have low charge density due to their larger size in spite of having high charge (+3). Hence, they do not cause much polarization of the ligands and have a weak tendency for complex formation. This reluctance for complex formation may be attributed mainly to:

- (i) The unfavourable electronic configuration on the lanthanide ions.
- (ii) The larger size which leads to little attraction for electron rich species.

Because of the above reasons, only the high energy 5d, 6s and 6p-orbitals are available for coordination, the 4f-orbitals being screened, so that only strong (usually chelating) coordinating groups can interact. Thus, only a few complexes with unidentate ligands are formed but stable complexes are formed by Ln^{3+} ions with chelating ligands such as (i) oxygen containing, *viz.*, EDTA, β -diketones, citric acid, oxalic acid, acetyl acetone, oximes, (ii) nitrogen containing, *viz.*, ethylene diamine, NCS, etc. The Ln^{3+} ions do not form complexes with π -bonding ligands such as CO, NO, CNR, etc., at all. The complex forming tendency and the stability of the complexes increases with increasing atomic number. This fact is taken as a basis to take advantage in their separation from one another. Ce(IV) complexes are relatively common, an example of high oxidation state ion seeking stabilization through complexation.

The most important class of lanthanide complexes are the anionic type. Complexation with hydroxycarboxylic acids such as citric and tartaric acid is used in the separation procedure of lanthanides. The EDTA complexes have achieved importance in the recent years. The coordination number of lanthanide complexes is usually six.

4.7 OCCURRENCE AND ISOLATION OF LANTHANIDE ELEMENTS

Except promethium which is unstable and occurs only in traces, all the lanthanides occur in nature to a considerable extent, cerium being the most abundant of all the elements. There are more than hundred minerals known to contain lanthanides but very few are of commercial importance. Monazite sand is the best known and most important mineral of lanthanide elements which is essentially a mixture of orthophosphates, LnPO_4 containing upto 12% thorium, the element of 5f-series, small amounts of Zr, Fe and Ti as silicates, lanthanum and about 3% yttrium. Among lanthanides contained in monazite, the bulk is of Ce, Nd, Pr and others occur in minute quantities.

Extraction of lanthanide metals

After conventional mineral dressing which gives minerals of more than 90 percent purity, the mineral is broken down by either acidic or alkaline attack. By making use of different solubilities of double salts: $\text{Ln}_2(\text{SO}_4)_3 \cdot \text{Na}_2\text{SO}_4 \cdot x\text{H}_2\text{O}$ for light and heavy lanthanides and low solubility of hydrated oxide of thorium, the lanthanide fractions and thorium containing portions are separated in acidic medium.

Monazite is treated with hot conc. H_2SO_4 when thorium, lanthanum and lanthanons dissolve as sulphates and are separated from insoluble material (impurities). On partial neutralisation by NH_4OH , thorium is precipitated as ThO_2 . Then Na_2SO_4 is added to the solution. Lanthanum and light lanthanides are precipitated as sulphates leaving behind the heavy lanthanides in solution. To the precipitate obtained as above, is added hot conc. NaOH . The resulting hydroxides of light lanthanides are dried in air at 100°C to convert the hydroxides to oxides. The oxide mixture is treated with dil. HNO_3 . This brings CeO_2 as precipitate and other lanthanides in solution. From the solutions obtained as above for heavy and light lanthanides, individual members of lanthanide series are isolated by the following methods:

Isolation of Individual Lanthanide Elements:

All the lanthanides have the same size and charge (of +3 unit). The chemical properties of these elements which depend on the size and charge are, therefore, almost identical. Hence, their isolation from one another is quite difficult. However, the following methods have been used to separate them from one another.

1. Fractional Crystallization Method:

This method is based on the difference in solubility of the salts such as nitrates, sulphates, oxalates, bromates, perchlorates, carbonates and double salts of lanthanide nitrates with magnesium nitrate which crystallize well and form crystals. Since, the solubility of these simple and double salts decreases from La to Lu, the salts of Lu will crystallize first followed by those of lighter members. The separation can be achieved by repeating crystallization process a number of

times. A non-aqueous solvent, *viz.*, diethyl ether has been used to separate $\text{Nd}(\text{NO}_3)_3$ and $\text{Pr}(\text{NO}_3)_3$.

2. Fractional Precipitation Method:

This method is also based on the difference in solubility of the precipitate formed, which is formed on addition of the precipitant, i.e. Precipitating agent. If a little amount of precipitant is added, the salt with lowest solubility is precipitated most readily and rapidly. For example, when NaOH is added to a solution of $\text{Ln}(\text{NO}_3)_3$, Lu-hydroxide being the weakest base and having the lowest solubility product is precipitated first while La-hydroxide which is the strongest base and has the highest solubility product is precipitated last. By dissolving the precipitate in HNO_3 and reprecipitating the hydroxides a number of times, it is possible to get the complete separation of lanthanide elements.

3. Valency change Method:

This method is based on the change of chemical properties by changing the oxidation state of the lanthanide elements. The most important application of this method is made in the separation of cerium and europium elements from mixture of lanthanides.

- (i) The mixture containing Ln^{3+} ions if treated with a strong oxidising agent such as alkaline KMnO_4 , only Ce^{3+} ion is oxidized to Ce^{4+} while other Ln^{3+} ions remain unaffected. To this solution alkali is added to precipitate $\text{Ce}(\text{OH})_4$ only, which can be filtered off from the solution.
- (ii) Eu^{2+} can be separated almost completely from Ln^{3+} ions from a solution by reducing it with zinc-amalgam and then precipitating as EuSO_4 on adding H_2SO_4 which is insoluble in water and hence can be separated. The sulphates of other Ln^{3+} ions are soluble and remain in solution.

4. Complex Formation Method:

This method is generally employed to separate heavier lanthanide elements from the lighter ones by taking the advantage of stronger complexing tendency of smaller cations with complexing agents. When EDTA is added to Ln^{3+} ion solution, lanthanides form strong complexes. If oxalate ions are added to the solution containing EDTA and Ln^{3+} ions, no precipitate of oxalates is obtained.

However, on adding small amount of acid, the least stable complexes of lighter lanthanides are dissociated and precipitated as oxalates, but the heavier lanthanides remain in solution as EDTA complexes.

5. Solvent Extraction Method:

This method is based on the difference in the values of partition coefficient of lighter and heavier lanthanides between two solvents, e.g., water and tri-butyl phosphate (TBP). Heavier lanthanides are more soluble in TBP than lighter ones whereas reverse trend of solubility is found in water and other ionic solvents. $\text{La}(\text{NO}_3)_3$ and $\text{Gd}(\text{NO}_3)_3$ have been separated by this method because the partition coefficient of Gd-nitrate in water and TBP is different from that of La-nitrate. Thus, Gd-nitrate can be separated from La-nitrate by continuous extraction with water from a solution of these salts in TBP in kerosene oil or by using a continuous counter-current apparatus which gives a large number of partitions automatically.

6. Modern Ion-Exchange Method:

This is the most rapid and most effective method for the isolation of individual lanthanide elements from the mixture. An aqueous solution of the mixture of lanthanide ions (Ln^{3+}aq) is introduced into a column containing a synthetic cation exchange resin such as DOWAX-50 [abbreviated as HR (solid)]. The resin is the sulphonated polystyrene containing $\text{-SO}_3\text{H}$ as the functional group. As the solution of mixture moves through the column, Ln^{3+}aq ions replace H^+ ions of the resin and get themselves fixed on it:

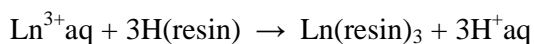

The H^+aq ions are washed through the column. The Ln^{3+}aq ions are fixed at different positions on the column. Since, Lu^{3+}aq is largest (Lu^{3+} anhyd. is smallest and is hydrated to the maximum extent) and Ce^{3+}aq is the smallest, Lu^{3+}aq ion is attached to the column with minimum firmness remaining at the bottom and Ce^{3+}aq ion with maximum firmness remaining at the top of the resin column. In order to move these Ln^{3+}aq ions down the column and recover them, a solution of anionic ligand such as citrate or 2-hydroxy butyrate is passed slowly through the column (called elution). The anionic ligands form complexes with the lanthanides which possess lower positive charge than the

initial Ln^{3+} aq ions. These ions are thus displaced from the resin and moved to the surrounding solutions as eluant- Ln complexes.

For example, if the citrate solution (a mixture of citric acid and ammonium citrate) is used as the eluant, during elution process, NH_4^+ ions are attached to the resins replacing Ln^{3+} aq. ions which form Ln-citrate complexes:

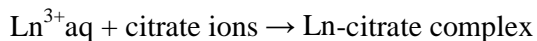
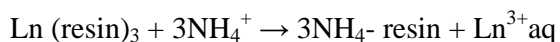

As the citrate solution (buffer) runs down the column, the metal ions get attached alternately with the resin and citrate ions (in solution) many times and travel gradually down the column and finally pass out of the bottom of the column as the citrate complex. The Ln^{3+} aq cations with the largest size are, eluted first (heavier Ln^{3+} aq ions) because they are held with minimum firmness and lie at the bottom of the column. The lighter Ln^{3+} aq ions with smaller size are held at the top of the column (with maximum firmness) and are eluted at last. The process is repeated several times by careful control of concentration of citrate buffer in actual practice.

4.8 LANTHANIDE COMPOUNDS

The lanthanides are very electropositive and reactive metals, the reactivity depends on the size. Europium with the largest size is most reactive. All the lanthanides generally give normal and complex compounds.

Oxides:

If lanthanide elements are ignited in air or O_2 , they readily form the oxides of Ln_2O_3 type except Ce which gives a dioxide, CeO_2 . The oxides are ionic and basic. The basic nature of oxides decreases along the series with decreasing ionic size.

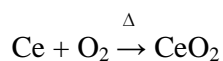
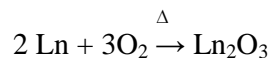

Ytterbium resists the action of air even at 1000°C due to the formation of a protective layer of oxide on its surface.

Hydroxides:

The lanthanides react slowly with cold water but readily with hot water:

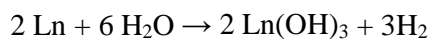

On adding aqueous ammonia to this aqueous solution, hydroxides are precipitated as gelatinous precipitate. These hydroxides are also ionic and basic, the basic nature decreasing with increasing atomic number. $\text{La}(\text{OH})_3$ is most basic and $\text{Lu}(\text{OH})_3$ is least basic. Their basic character is more than that of $\text{Al}(\text{OH})_3$ but less than that of $\text{Ca}(\text{OH})_2$.

Oxo-salts:

Lanthanides form oxo-salts such as nitrates, sulphates, perchlorates and salts of oxo-acids which are soluble in water but carbonates and oxalates are insoluble. The difference in basicity is responsible for the difference in thermal stability of the oxo-salts which decreases along the series. Thus, $\text{La}(\text{NO}_3)_3$ is more stable than $\text{Lu}(\text{NO}_3)_3$.

Halides and Hydrides:

The lanthanides also burn in halogens to produce LnX_3 type halides and combine with H_2 at high temperature to give stable MH_2 or MH_3 type hydrides. Among halides, fluorides are insoluble but other halides are soluble in water.

Ln also form complexes with chelating ligands, the detailed account has been given earlier.

4.9 SUMMARY

The present unit covers all the important and interesting aspects of lanthanides such as their electronic structure, oxidation states, ionic radii and corresponding lanthanide contraction, consequences of lanthanide contraction, complex formation by lanthanides, their occurrence, extraction and various methods employed for the

isolation of the elements and a brief account of the lanthanide compounds. The readers can understand well all these aspects after going through the unit text.

4.10 TERMINAL QUESTIONS

1. Why are the lanthanides grouped together?
2. Why the f-block elements are also called the inner transition elements?
3. Give a brief account of lanthanide contraction.
4. The number of f-electrons in Eu^{2+} and Yb^{2+} ions is
 - (a) 7 and 14
 - (b) 7 and 13
 - (c) 6 and 14
 - (d) 6 and 13
5. Tb^{4+} ions are stable, explain.
6. Discuss the ion exchange method of isolation of lanthanides.
Which one is more basic $\text{La}(\text{OH})_3$ or $\text{Lu}(\text{OH})_3$ and why?

4.11 Answers

4. (a)
5. Due to $4f^7$ valence shell electronic configuration.
6. $\text{La}(\text{OH})_3$ due to larger cationic size

For answers to other questions, please refer to the text.

UNIT-5 CHEMISTRY OF THE ACTINIDE ELEMENTS

CONTENTS:

- 5.1 Objectives
- 5.2 Introduction
- 5.3 General features
- 5.4 Chemistry of actinides
- 5.5 Separation of Np, Pu and Am from U
- 5.6 Similarities between the latter actinides and the latter lanthanides
- 5.7 Summary
- 5.8 Terminal Questions
- 5.9 Answers

5.1 OBJECTIVES

The objectives of writing this unit are to make the readers well acquainted with various aspects of the actinide or 5f-block elements such as the general features of these elements, e.g., their occurrence and nature, their electronic structure, oxidation states, complex formation tendency, magnetic and spectral properties, atomic and ionic sizes, etc. as well as to throw light on the chemistry of the actinides and the chemistry of separation of Np, Pu and Am from U. It is also aimed at to discuss the similarities between lanthanides and actinides.

5.2 INTRODUCTION

The group of fourteen elements from thorium (Th, $Z = 90$) to lawrencium (Lr, $Z=103$) are called actinides, actinoids or actinons. These are named so because these elements succeed the element actinium (Ac, $Z = 89$). These elements are also known as inner-transition elements as they lie between actinium and rutherfordium (Rf, $Z = 104$), i.e., the elements of fourth transition series. Thus, they constitute the second inner-transition series of which actinium is the prototype.

In these elements 5f-subshell of the antepenultimate shell ($n=7$) is successively filled by the additional or differentiating electrons, one at a time in each step, which are embedded in the interior while 6d- and 7s-electons are exposed to the surroundings.

In the outermost and penultimate shell of these elements, the number of electrons remains almost the same. That is why the actinide elements resemble one another very closely. The actinides lying beyond uranium, i.e., the elements with $Z = 93$ to 103 are called transuranium elements. The first and the last elements of 5f-series have been mentioned above with their names and symbols, i.e., Th and Lr. The remaining twelve elements are listed below:

protactinium (Pa, $Z = 91$), uranium (U, $Z = 92$), neptunium (Np, $Z = 93$), plutonium (Pu, $Z = 94$), americium (Am, $Z = 95$), curium (Cm, $Z = 96$), berkelium (Bk, $Z = 97$), californium (Cf, $Z = 98$), einsteinium (Es, $Z = 99$), fermium (Fm, $Z = 100$), mendelevium (Md, $Z = 101$) and nobelium (No, $Z = 102$).

These elements of 5f-series are also said to belong to Group 3 and Period 7 and have been allotted a position below those of 4f-series in the periodic table and thus the elements of both f-series have been placed separately below the main body of table to avoid unnecessary expansion of the periodic table.

5.3 GENERAL FEATURES OF THE ACTINIDES

(1) Occurrence and Nature

Only the first four elements, *viz.*, Ac, Th, Pa and U occur in nature in uranium minerals that too only Th and U occur to any useful extent. All the remaining actinides, i.e. trans uranium elements are unstable and are made artificially. The elements above Fm ($Z = 100$) exist as short lived species, some of them existing only for a few seconds. All the actinides are radioactive in nature.

(2) Electronic structure (or Configuration)

The electronic configuration of actinium ($Z = 89$) which is followed by fourteen actinides is $[Rn]5f^06d^17s^2$, the last electron entering the 6d-subshell. In the next element, Th, the first member of the actinide series, the additional electron must enter 5f-subshell and the filling of 5f-subshell must continue progressively till the last element, Lr. Thus, 6d-subshell in all the elements must remain singly filled thereby giving the expected valence shell configuration of $5f^{1-14}6d^17s^2$ for these elements. Since, the energies of 6d- and 5f- subshells are almost the same and the atomic spectra of the elements are very complex, it is difficult to identify the orbital in terms

of quantum numbers as well as to write down the configuration. For chemical behaviour, the valence shell electronic configuration of the elements is of great importance and the competition between $5f^n 6d^0 7s^2$ and $5f^{n-1} 6d^1 7s^2$ is of interest. It has been observed that the electronic configuration of actinides does not follow the simple pattern as is observed for the lanthanides. For the first four actinide elements, *viz.*, Th, Pa, U and Np, due to almost equal energies of 5f and 6d, the electrons may occupy the 5f or 6d subshells or sometimes both. From Pu (Z=94) onwards, $6d^1$ electron gets shifted to 5f-subshell except for Cm (Z=96) and Lr (Z=103) in which $6d^1$ electron does not shift to 5f due to stable $5f^7$ and $5f^{14}$ configurations. In view of the above considerations, the general valence shell electronic configuration of the actinide elements may be written as: $5f^{0-14} 6d^{0-2} 7s^2$. For individual elements the observed or actual valence shell configurations are listed below:

Element (Z)	Valence shell configuration	Element (Z)	Valence shell configuration
Thorium (90)	$5f^0 6d^2 7s^2$	Berkelium (97)	$5f^9 6d^0 7s^2$
Protactinium (91)	$5f^2 6d^1 7s^2$	Californium (98)	$5f^{10} 6d^0 7s^2$
Uranium (92)	$5f^3 6d^1 7s^2$	Einsteinium (99)	$5f^{11} 6d^0 7s^2$
Neptunium (93)	$5f^4 6d^1 7s^2$	Fermium (100)	$5f^{12} 6d^0 7s^2$
Plutonium (94)	$5f^6 6d^0 7s^2$	Mendelevium (101)	$5f^{13} 6d^0 7s^2$
Americium (95)	$5f^7 6d^0 7s^2$	Nobelium (102)	$5f^{14} 6d^0 7s^2$
Curium (96)	$5f^7 6d^1 7s^2$	Lawrencium (103)	$5f^{14} 6d^1 7s^2$

From the above valence shell configurations of the actinide elements, it is clear that Th does not have any f-electron though this element belongs to 5f-series (i.e., actinides). For Pa, U, Np, Cm and Lr, both the expected and observed (actual) configurations are same. For the rest of the actinides, 6d-subshell does not contain any d-electron.

(3) Oxidation States

The important oxidation states exhibited by actinides are compiled below in the tabular form. Some of them are stable but most of these oxidation states are unstable. It may be seen from these oxidation states that the +2 state is shown by Th and Am

only in the few compounds like ThBr_2 , ThI_2 , ThS , etc. The +3 oxidation state is exhibited by all the elements and it becomes more and more stable as the atomic number increases. The +4 oxidation state is shown by the elements from Th to Bk, the +5 oxidation state by Th to Am, the +6 state by the elements from U to Am and the +7 state is exhibited by only two elements, viz., Np and Pu. Np in the +7 state acts as an oxidising agent.

The principal cations given by actinide elements are M^{3+} , M^{4+} and oxo-cations such as MO_2^+ (oxidation state of M = + 5) and MO_2^{2+} (oxidation state of M = +6). The examples of oxo-cations are UO_2^+ , PuO_2^+ , UO_2^{2+} and PuO_2^{2+} which are stable in acid and aqueous solutions. Most of the M^{3+} ions are more or less stable in aqueous solution. Np^{3+} and Pu^{3+} ions in solution are oxidized to Np^{4+} and Pu^{4+} by air. The latter ions are further oxidized slowly to UO_2^{2+} and PuO_2^{2+} by air. Various oxidation states of the actinides are listed below:

Element	Oxidation states	Element	Oxidation states
Th	+2, +3, +4	Bk	+3, +4
Pa	+3, +4, +5	Cf	+3
U	+3, +4, +5, + 6	Es	+3
Np	+3, +4, +5, +6, +7	Fm	+3
Pu	+3, +4, +5, +6, +7	Md	+3
Am	+2, +3, +4, +5, +6,	No	+3
Cm	+3, +4	Lr	+3

The lighter elements up to Am show variable oxidation states, the maximum being for Np, Pu and Am, but the heavier elements show constant oxidation state of +3.

(4) Atomic and Ionic Radii

The atomic (metallic) and ionic radii of cations in common oxidation states (i.e. M^{3+} and M^{4+} cations) of some of the actinide elements have been evaluated. A look into the values of the atomic radii reveals that the metallic radii first decrease from Th to Np and then increase gradually up to Bk. For the higher actinides the values are not known. The values of ionic radii for both types of ions go on decreasing. This steady fall in the ionic radii along the actinide series is called actinide contraction which is

analogous to lanthanide contraction found in lanthanides. The cause of actinide contraction is the same as has been discussed for the lanthanides. Here also, increasing nuclear charge and poor shielding effect of 5f-electrons play an important role. The atomic and ionic radii are listed below:

Element	Atomic radius (pm)	Ionic radius of M^{3+} ion (pm)	Ionic radius of M^{4+} ion (pm)
Th	180	108	96
Pa	164	105	93
U	157	103	92
Np	156	101	91
Pu	160	100	90
Am	174	99	89
Cm	175	99	88
Bk	176	98	87
Cf	-	97	-

It is clear from above table that there is only a small variation in the atomic and ionic radii of the actinide elements; hence they show similar chemical properties.

(5) Magnetic and Spectral Properties

It has already been mentioned that the paramagnetic nature of the substances is due to the presence of unpaired electrons. The actinide elements like lanthanides show paramagnetism in the elemental and ionic states. Tetravalent thorium (Th^{4+}) and hexavalent uranium (U^{6+}) ions are diamagnetic due to the absence of unpaired electrons. $Th^{4+} = U^{6+} = Rn$ ($Z= 86$) structure (diamagnetic, paired electrons). Since, actinides constitute second f-series, it is natural to expect similarities with lanthanides (the first f series) in their magnetic and spectroscopic properties. But, there are some differences between the lanthanides and actinides. Spin-orbit coupling is strong ($2000-4000cm^{-1}$) in the actinides as happens in the lanthanides but because of the greater exposure of the 5f-electrons, crystal field splitting is now of comparable magnitude and J is no longer such a good quantum number. It is also noted that 5f- and 6d-subshells are sufficiently close in energy for the lighter actinides to make 6d-

levels accessible. As a result each actinide compound has to be considered individually. This must allow the mixing of J levels obtained from Russel-Saunders coupling and population of thermally available excited levels.

Accordingly, the expression $\mu = g\sqrt{J(J+1)}$ is less applicable than for the lanthanides and magnetic moment values obtained at room temperature are usually lower and are much more temperature dependent than those obtained for compounds of corresponding lanthanides.

The electronic spectra of actinide compounds arise from the following three types of electronic transitions:

- (a) **f-f transitions:** These are Laporte (orbitally) forbidden but the selection rule is relaxed partially by the action of crystal field in distorting the symmetry of the metal ion. Because the actinides show greater field, hence the bands are more intense. These bands are narrow and more complex, are observed in the visible and UV regions and produce the colours in aqueous solutions of simple actinide salts.
- (b) **5f-6d transitions:** These are Laporte and spin allowed transitions and give rise to much more intense bands which are broader. They occur at lower energies and are normally confined to the UV region hence do not affect the colours of the ions.
- (c) **Metal to ligand charge transfer:** These transitions are also fully allowed and produce broad, intense absorptions usually found in UV region, sometimes trailing in the visible region. They produce the intense colours which are characteristic of the actinide complexes.

The spectra of actinide ions are sensitive to the crystal field effects and may change from one compound to another. It is not possible to deduce the stereochemistry of actinide compounds due to complexity of the spectra. Most of the actinide cations and salts are coloured due mainly to f-f transitions. Those with f^0 , f^7 and f^{14} configurations are colourless. The colours of some of the compounds in different oxidation states are given below:

NpBr_3 : green; NpI_3 : brown; NpCl_4 : red-brown; NpF_6 : brown

PuF_3 : purple; PuBr_3 : green; PuF_4 : brown; PuF_6 : red brown

AmF_3 : pink; AmI_3 : yellow; AmF_4 : dark tan.

The coordination chemistry of actinides is more concerned with aqueous solutions. Because of the wider range of oxidation states available in actinides, their coordination chemistry is more varied. Most of the actinide halides form complex compounds with alkali metal halides. For example, ThCl_4 with KCl forms complexes such as $\text{K}[\text{ThCl}_5]$ and $\text{K}_2[\text{ThCl}_6]$, etc. ThCl_4 and ThBr_4 also form complexes with pyridine, e.g. $\text{ThCl}_4 \cdot \text{py}$. Chelates are formed by the actinides with multidentate organic reagents such as oxine, EDTA, acetyl acetone, etc.

The actinides with small size and high charge have the greatest tendency to form complexes. The degree of complex formation for the various ions decreases in the order: $\text{M}^{4+} > \text{MO}_2^{2+} > \text{M}^{3+} > \text{MO}_2^+$. The complexing power of different anions with the above cations is in the order:

Monovalent anions : $\text{F}^- > \text{NO}_2^- > \text{Cl}^-$

Bivalent anions : $\text{CO}_3^{2-} > \text{C}_2\text{O}_4^{2-} > \text{SO}_4^{2-}$

5.4 CHEMISTRY OF ACTINIDES

The actinide elements are highly electropositive and reactive. They show similar properties to those of lanthanides. But these elements have much higher tendency to form complexes. They react with water and tarnish in air forming oxide coating. They react readily with HCl but slowly with other acids. The metals show basic nature and do not react with NaOH but they react with halogens, oxygen and hydrogen to form halides, oxides and hydrides. Some of the compounds of the actinides are discussed below:

- (i) **Oxides:** The metals on reacting with air or oxygen give various oxides under different experimental conditions. Uranium is one of the reactive elements and gives the oxides: UO , UO_2 , U_3O_8 and UO_3 :

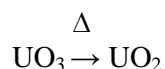
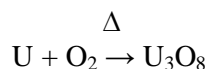

Similarly, the oxides of Np, Pu and Am are: NpO, NpO₂, Np₃O₈, PuO, Pu₂O₃, Pu₂O₇, PuO₂, AmO and AmO₂.

- (ii) **Hydrides, nitrides and carbides:** U and Pu form hydrides UH₃ and PuH₃, by the direct union of the elements. U reacts with H₂ even at room temperature but the reaction is faster at 250 °C as compared to room temperature:

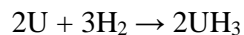

This compound is reactive and is hydrolysed by water:

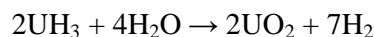

This also reacts with Cl₂, HF and HCl as follows:

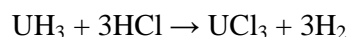
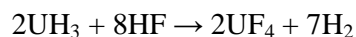
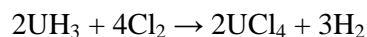

When treated with ammonia, the metals give nitrides of the type : UN, U₂N₃, UN₂ and PuN.

These metals also give carbides: UC and PuC.

All the MX type compounds where M = U, Np, Pu or Am and X = O, C or N have the rock-salt (or NaCl) structure.

- (iii) **Halides:** Actinide elements on reacting with halogens or hydrogen halides form halides, the most common being those of U and Np. Trihalides of MX₃ type are formed by the actinides which are isomorphous with one another. Some of the actinides also form the tetra, penta and hexa halides as well. For example, U fluorides are obtained as is shown by the following reactions:

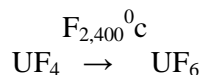
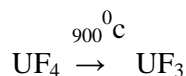
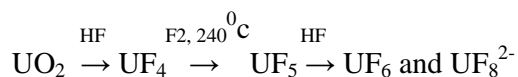

Np, Pu and Am are also reactive similar to U and give the analogous reactions and products. Some examples of halides are : UF_6 , UF_5 , UF_4 , UF_3 , UCl_4 , UCl_3 , UBr_4 , UBr_3 , NpF_6 , NpF_4 , NpF_3 , NpCl_3 , NpI_3 , etc.

5.5 CHEMISTRY OF SEPARATION OF NP, PU AND AM FROM U

Although several isotopes of Np, Pu and Am elements are known yet only a few are obtained. But Np^{237} and Pu^{239} are found in the uranium fuel elements of nuclear reactors from which Pu is isolated on a kilogram scale. Np^{237} is also found in substantial amounts and is recovered primarily for conversion by neutron irradiation of NpO_2 into Pu^{238} which is used as a power source for satellites. Am produced from intense neutron irradiation of pure plutonium. The main problem involved in the extraction of these elements includes the recovery of the expensive signatory material and the removal of hazardous fission products that are formed simultaneously in amounts comparable to the amount of the synthetic elements themselves. There are various methods available for the separation of Np, Pu and Am which are based on precipitation, solvent extraction, differential volatility of compounds and ion exchange. The chemistry of the most important methods of separation is given below:

(a) Method based on stabilities of oxidation states

The stabilities of major ions of these elements involved are $\text{UO}_2^{2+} > \text{NpO}_2^{2+} > \text{PuO}_2^{2+} > \text{AmO}_2^{2+}$ and $\text{Am}^{3+} > \text{Pu}^{3+} \gg \text{Np}^{3+} > \text{U}^{4+}$. By choosing a suitable oxidising or reducing agent, it is possible to obtain a solution containing the elements in different oxidation states. The elements can then be separated by precipitation or solvent extraction method. For example, Pu can be oxidized to PuO_2^{2+} whereas Am remains as Am^{3+} . Thus PuO_2^{2+} can be easily removed by solvent extraction or Am^{3+} by precipitation as AmF_3 .

(b) Method based on extraction by using organic reagents

It is a well known fact that MO_2^{2+} ions can be extracted from nitrate solutions into organic solvents. The M^{4+} ions can be extracted into tributyl phosphate in kerosene from 6M- HNO_3 solution. Similarly M^{3+} ions can be separated from 10-16M HNO_3 . Thus, the actinides close to each other can be separated by changing the conditions.

(c) Method based on precipitation

The actinide ions in M^{3+} or M^{4+} state only give insoluble fluorides or phosphates in acid solution. In the higher oxidation states these elements are either soluble or can be prevented to get precipitated by complex formation with sulphate or other ions.

(d) Method based on ion-exchange

This method has been found suitable for small amount of material. In this method, both cationic and anionic ion ex`changers can be used to separate the actinide ions. The separation of the actinides by ion-exchange methods is given below:

1. **Isobutyl methyl ketone method:** In this method the following scheme is used:

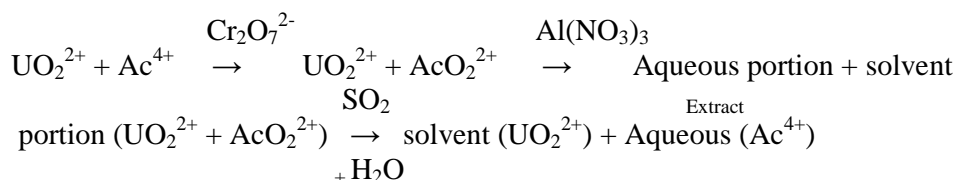

The two layers are separated and collected. Here Ac^{4+} represents the actinide ions

such as Np^{4+} , Pu^{4+} and Am^{4+} .

2. **Tributyl phosphate method:** This method is dependent on the difference in extraction coefficients from 6N- HNO_3 into 30% tributyl phosphate in kerosene.

The order of extraction is :

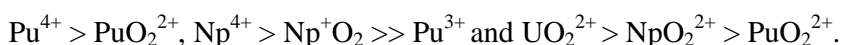

The Ac^{3+} ions have very low extraction coefficients in 6M- HNO_3 but in 12M- HCl or 16M- HNO_3 the extraction increases. The order of extraction is: $\text{Np} <$

Pu

$< \text{Am} < \text{Cm}$, etc. In this method the scheme used is as follows:

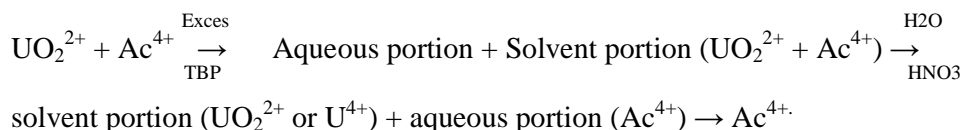

Repeat extraction to get Ac^{4+} . Here also, Ac = Actinide particularly Np and Pu .

3. **Method Based on Lanthanum fluoride cycle:** This method was developed for the isolation of Np but has been found to be of great utility in the separation of Pu from U . The scheme used for the separation is given below:

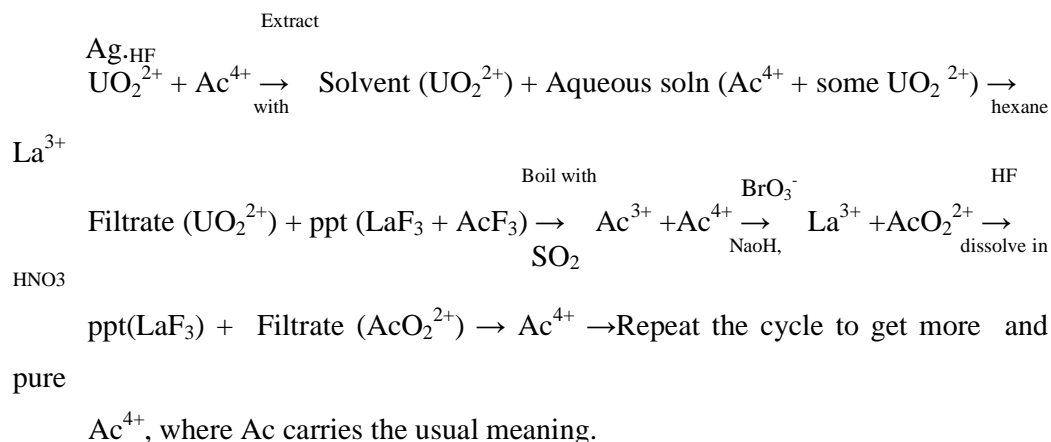

5.6 SIMILARITIES BETWEEN LANTHANIDES AND ACTINIDES

- (i) In the atoms of the elements of both the series, three outermost shells are partially filled and remaining inner shells are completely filled but the additional or differentiating electron enters (n-2) f-subshell.
- (ii) The elements of both series exhibit +3 oxidation state which is prominent and predominant state.
- (iii) Like Lanthanide contraction found in the lanthanide elements, there occurs contraction in size in the actinide elements called actinide contraction. Both the contractions are due to poor shielding effect produced by f-electron with increasing nuclear charge.
- (iv) The elements of both the series are quite reactive and are electropositive.
- (v) The electronic absorption bands of the elements of both the series are sharp and appear like lines. These bands are produced due to f-f transitions within (n-2)f-subshell though such transitions are orbital forbidden.
- (vi) Most of the lanthanide and actinide cations are paramagnetic.
- (vii) The nitrates, perchlorates and sulphates of trivalent lanthanide and actinide elements are soluble while the hydroxides, fluorides and carbonates of these elements are insoluble.
- (viii) The lanthanide and actinide elements show similarity in properties among their series though the lanthanides are closer among themselves in properties as compared to actinides.

5.7 SUMMARY

The text material of this unit contains the introductory part which is quite interesting and important from the view point of the readers and a detailed account of the general features of the actinides such as their occurrence, electronic structure, oxidation states which have greater variability than those of lanthanides, atomic and ionic radii-the actinide contraction, their magnetic and spectral properties along with exhibition of colour, formation of complexes, etc has been given.

The chemistry of actinides including the formation of various compounds, e.g., oxides, hydrides, nitrides, carbides and halides in various oxidation states has also been discussed. The unit also contains a detailed account of the chemistry of separation of Np, Pu and Am from U including the method used for separation. At last the points of similarities between the lanthanides and actinides have been mentioned.

5.8 TERMINAL QUESTIONS

1. Why do actinides show higher oxidation states than lanthanides?
2. Oxocations MO_2^{2+} are formed by U, Np, Pu and Am only whereas heavier actinides do not form such ions, why?
3. The elements beyond atomic number 102 are unstable, Explain.
4. Write the electronic configuration of Th, Cm and No.
5. Name the actinides along with their symbols and atomic numbers.
6. Which actinide ion in +3 oxidation state has just half-filled 5f-subshell?
 - (a) Pu^{3+}
 - (b) Am^{3+}
 - (c) Cm^{3+}
 - (d) Bk^{3+}
7. The first member of the post actinide transition series is:
 - (a) Rutherfordium
 - (b) Seaborgium
 - (c) Meitnerium
 - (d) Hahnium

5.9 ANSWERS

1. Due to high charge density actinides are capable of forming oxo cations in which these elements show higher oxidation states.
2. Because the tendency of disproportionation of these oxocations increases with increasing atomic number. Hence the oxocations of heavier actinides do not exist.
3. Beyond atomic number 102, the size of nucleus increases thereby decreasing the nuclear stability. This causes lower probability of existence of stable elements beyond this atomic number.
4. & 5. Pl. refers to the text.
6. c
7. a

5.10 BOOKS/REFERENCES CONSULTED

1. Advanced Inorganic Chemistry: F.A. Cotton and G. Wilkinson, John Wiley and Sons, New York.
2. Inorganic Chemistry: Alan G. Sharpe, ELBS and Longman, Essex England.
3. Principles of Inorganic Chemistry: B.R. Puri, L.R. Sharma and K.C. Kalia, Milestone Publishers & Distributors, Delhi.
4. Selected Topics in Inorganic Chemistry: W.U. Malik, G.D. Tuli and R.D. Madan, S. Chand and Co. Ltd., New Delhi.
5. Comprehensive Inorganic Chemistry: Suleka Chandra, New Age International (P) Limited. Publishers, New Delhi.
6. Advance Inorganic Chemistry Vol. II: S. Prakash, G.D. Tuli et al., S. Chand and Co. Ltd., and New Delhi.

UNIT-6 COORDINATION COMPOUNDS

CONTENTS:

- 6.1 Objectives
- 6.2 Introduction
 - 6.2.1 Ligand and their type
 - 6.2.1.1 Type I- Based on electron acceptor/donor properties of the ligand.
 - 6.2.1.2 Type II- Based on the number of donor atoms in the ligand.
 - 6.2.1.3 Type III- Based on size of ligand
 - 6.2.1.4 Type IV- Based on their use in reactions
 - 6.2.2 Complex ion
 - 6.2.3 Coordination number
 - 6.2.4 Coordination sphere
 - 6.2.5 Counter ion
- 6.3 Werner's Coordination Theory and its experimental verification
- 6.4 Effective Atomic Number concept
- 6.5 Chelates
 - 6.5.1 Applications of Chelates
 - 6.5.2 Stability of Chelates
- 6.6 Nomenclature of Coordination Compounds
- 6.7 Summary
- 6.8 Definitions
- 6.9 Questions for practice
 - 6.9.1 Short answer questions
 - 6.9.2 True (T) or False (F)
- 6.10 Bibliography
- 6.11 Long answer questions
- 6.12 Answers

6.1 OBJECTIVES

By the end of this Unit, you will be able to define the following terms:

- Coordination compound,
- Ligand,
- Coordination number (CN),
- Complex ion,
- Coordination sphere,
- Chelate,
- Primary valency,
- Secondary valency,
- Effective Atomic Number (EAN),

- Applications of coordination compounds,
- Name of coordination compounds,
- How to determine oxidation state of metal ion in a coordination compound.

6.2 INTRODUCTION

You have already studied in your earlier classes that there are two types of compounds. The compounds that can easily dissociate into their constituent ions in aqueous medium are called simple salts and double salts such as NaCl, MgCl₂, FeSO₄·(NH₄)₂SO₄·6H₂O, K₂SO₄·Al₂(SO₄)₃·24H₂O, etc. On the otherhand, the compounds which do not dissociate into their constituent ions in any solvent are known as coordination or complex compounds such as [Cu(NH₃)₄]²⁺. Transition metals have an ability to form a number of coordination compounds due to their small size, high charge and presence of empty d orbitals on the metal ion. A compound formed from the union of metal ion (an electron deficient species, central metal atom/ion; Lewis acid) and electron rich species (ligand; Lewis base) which can donate one electron pair is called coordination compound or complex compound. The coordination compounds can be represented by the general formula, [ML_n]^{±m}, where M is a metal ion, L is electron rich species; n is the number of L attached to the metal atom/ion and m is the charge on complex ion.

Some metal complexes were prepared and used in the eighteenth century in the form of metal salts and vegetable extracts as paints. The first well known coordination compound was Prussian blue, Fe₄[Fe(CN)₆]₃ in the beginning of eighteenth century. In 1798, CoCl₃·6NH₃ was discovered. Werner gave a theory to understand the bonding in such compounds about a century later in 1893. We are studying chemistry of coordination compounds because they have many applications in analytical / environmental chemistry, metallurgy, biological systems, industries and medicine.

6.3.2 Ligands and their types

The electron rich species, which may be charged species, e.g. Cl⁻, CN⁻, NO₂⁻, etc or neutral species e.g. H₂O, NH₃, NH₂CH₂C₂NH₂, CO, NO, etc., that can donate an electron pair to the metal atom/ion are called ligands.

6.2.1 Types of ligands

The ligands can be classified in the following ways:

6.2.2.1 Type I- Based on electron acceptor/donor properties of the ligand

- **σ (sigma) donor ligands** are those ligands which can only donate electron pair to the metal ion, e.g. H_2O , NH_3 , F^- . These ligands are also known as weak field ligands.
- **σ (sigma) donor and Π (pi) acceptor ligands** are those ligands which can donate electron pair and also have a tendency to accept electron in their empty antibonding π molecular orbitals (MO). Such ligands can involve in backbonding (π bond) with the metal ion. For example, CO , CN^- , NO , etc. These ligands are also known as strong field ligands.
- **Π (pi) donor ligands are those ligands** like benzene and ethylene, which do not have lone pair of electrons but only π electrons for donation to the metal atom/ion.

6.2.2.2 Type II- Based on the basis of number of donor atoms in the ligand

- **Monodentate or unidentate ligands**

The ligands that bound to a metal ion through a single donor atom are called as monodentate or unidentate ligands, e.g. Cl^- , H_2O or NH_3 . These ligands can be further divided into the following subclasses on the basis of charge (**Figure 6.1**).

- **Ambidentate ligands**

Some ligands have two or more than two different donor atoms. These ligands can attach through any of the donor atoms. They are given different names depending upon nature of the donor atom linked to the metal atom. These ligands are known as ambidentate ligands e.g. NO_2 (donor atom may be either N or O), SCN^- (donor atom may be either S or N), CN^- (donor atom may be either C or N), $\text{S}_2\text{O}_3^{2-}$ (donor atom may be either S or N). These are also monodentate ligands.

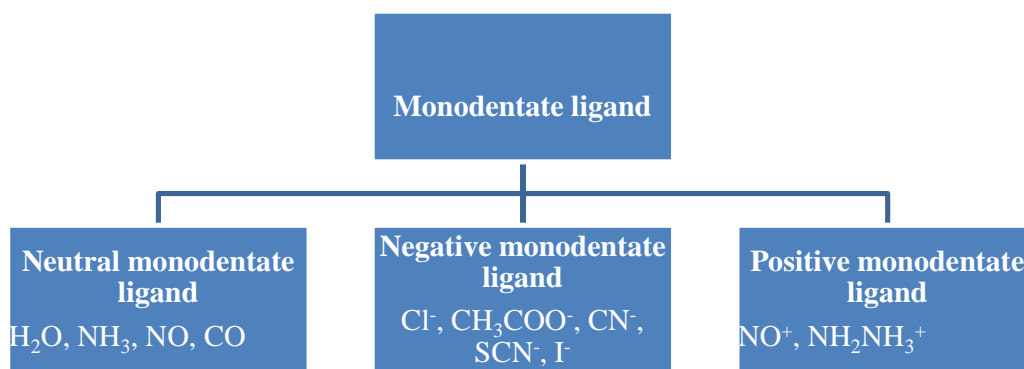
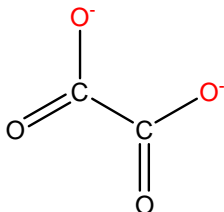
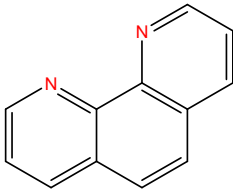
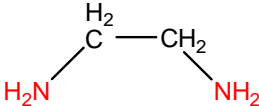
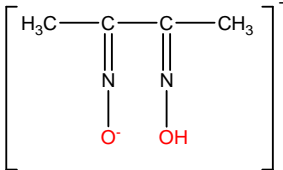
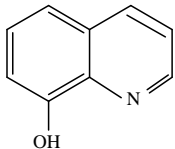
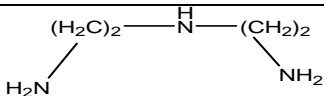

Figure 6.1: Classification of monodentate ligands

- **Polydentate (bidentate, tridentate, tetradentate, pentadentate, hexadentate) ligands**

These ligands bind to a metal atom/ion through two, three, four, five and six donor atoms, respectively. These ligands are also known as chelating ligands. These ligands form ring type (chelates) compounds (**Table 6.1**).

Table 6.1: Polydentate ligands

Ligand type	Ligand name	Ligand formula/structure
Bidentate	oxalate ion	
	1,10-phenanthroline	
	ethylenediamine (en)	
	dimethylglyoxime	
	8-hydroxyquinoline	
Tridentate	diethylenetriamine	

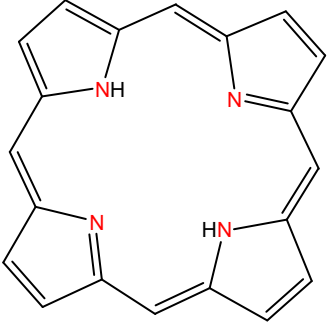
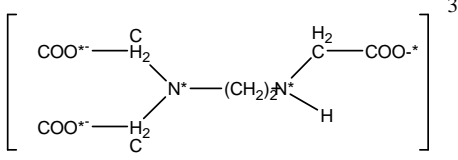
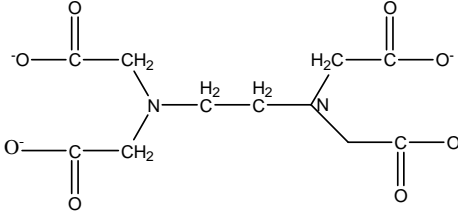
Tetradentate	triethylenetetramine porphyrin ring	$\text{NH}_2(\text{CH}_2)_2\text{NH}(\text{CH}_2)_2\text{NH}(\text{CH}_2)_2\text{NH}_2$ 
Pentadentate	ethylenediaminetriacetato	
Hexadentate	ethylenediaminetetraacetate (EDTA)	

Red colour letter in the structure represents the donor atom of the ligand.

6.2.2.3 Type III- Based on size of ligand

- Chelating ligands** are those ligands that bind via more than one atom and form chelate complexes (ring complexes). These complexes are more stable than complexes formed from monodentate ligands. The enhanced stability is known as the chelate effect.
- Macrocyclic ligands** are the chelating ligands that can form a large ring and surround the central atom or ion partially or fully and bond to it. The central atom or ion resides at the centre of the large ring. This complex formed is more rigid and inert as compared to the chelate compound and is known as macrocyclic complex. Heme is a macrocyclic complex in which the central iron atom is present at the centre of a porphyrin macrocyclic ring. Dimethylglyoximate complex of nickel is a synthetic macrocycle formed from

the reaction of nickel ion with dimethylglyoxime (**Figure 6.2**) in ammoniacal medium.

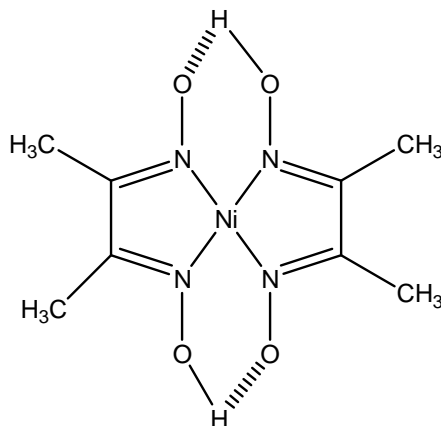

Figure 6.2: Nickel(II) bisdimethylglyoximate

The order of ligands to form stable compounds

Macrocyclic > Chelate > Monodentate

6.2.2.4 Type IV- Based on their use in reactions

- **Actor ligands** are those ligands which take part in chemical reaction.
- **Spectator ligands are tightly coordinating polydentate ligands** which do not take part in a chemical reaction. Phosphines, allyl groups in catalysis, trispyrazolylborates (Tp), cyclopentadienyl ligands (Cp) and many chelating diphosphines such as 1,2-bis(diphenylphosphino) ethane ligands (dppe) are spectator ligands.

6.2.2 Complex ion

A complex ion is an ion in which the metal ion is present at the center and a definite number of ligands surround it. The complex ion is enclosed in a large bracket. e.g.

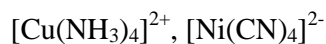

6.2.3 Coordination number (CN)

The coordination number of a metal atom/ion is the number of ligands attached to it in a complex compound. Coordination number may be two, three, four, five, six, seven, eight, nine or even higher in case of lanthanides and actinides



(Table 6.2). Coordination number depends on size, charge and electronic configuration and nature of metal/ion and ligands. For example,

- large metal atoms show high CN
- bulky ligands reduce coordination number
- Lewis bases easily donate electrons to metals and metals with lesser number of electrons can easily accept electrons.

Table 6.2: Coordination numbers (CN) and geometry of coordination compounds

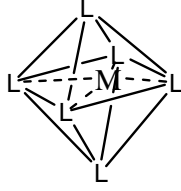
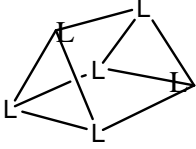
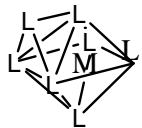
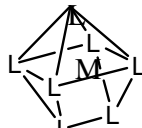
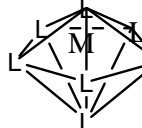
S.N.	CN	Metals	Ligands	Type of geometry	Geometry of complex
1	2	d-electron rich metals like Cu^+ , Ag^+ $[\text{Ag}(\text{NH}_3)_2]^+$ $[\text{Cu}(\text{NH}_3)_2]^+$ (uncommon)	Large ligands CH_3	Linear	
2	4	Small, high oxidation state, lower d metals d^8 metal atoms or ions such as Ni^{2+} , Rh^+ , Ir^+ , Pt^{2+} , Pd^{2+} , $\text{Au}^{3+, 6+}$ $[\text{Cu}(\text{NH}_3)_4]^{2+}$ $[\text{Zn}(\text{CN})_4]^{2-}$	Large Pi bonding ligands	Tetrahedral Square planar	
3	5	Allows fluxionality and Berry pseudorotation $[\text{Ni}(\text{CN})_5]^{3-}$ (Rare)		Trigonal bipyramidal Square pyramidal	

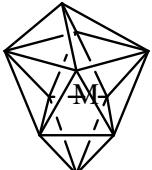
4	6	$[\text{Fe}(\text{H}_2\text{O})_6]^{2+}$ $[\text{Ni}(\text{NH}_3)_6]^{2+}$ $[\text{Fe}(\text{CN})_6]^{4-}$ (Very common) (Rare)	All types of ligands Three bidentate ligands such as dithiolates or oxalates	Octahedral Trigonal prismatic	 
5	7	Generally shown by rare earths $\text{K}_3[\text{NbOF}_6]$ (Very rare) Uncommon		Capped octahedron Capped trigonal prism Pentagonal bipyramid	  
6	8	Generally shown by rare earth metal ions (Very rare) Large metal ions (Rare) Uncommon	For eight equivalent ligands	Dodecahedron Cube Square antiprism	

		Common		Hexagonal bipyramida l	
7	9	Very rare		Three-face centred trigonal prism (Tricapped trigonal prism)	
8	10	Generally shown by rare earth elements		Bicapped square antiprism	
AA	11	Very rare		All-faced capped trigonal prism (Octadecah edron)	
10	12	Generally shown by rare earths		Icosahedro n	

6.2.4 Coordination sphere

The coordination sphere of a coordination compound comprises the central metal atom/ion and ligands attached to it. The coordination sphere is enclosed in brackets [].



6.2.5 Counter ions:

The ions excluding the coordination sphere are called as counter ions. In $K_4[Fe(CN)_6]$ compound, K^+ is the counter ion.

6.3 WERNER'S COORDINATION THEORY AND ITS EXPERIMENTAL VERIFICATION

Alfred Werner in 1893 suggested a new theory for explaining the nature of bonding in coordination compounds known as Werner's theory. According to this theory, there are two kinds of valences of metal atom/ion in coordination compounds: primary and secondary valences

- The attachment of species that satisfy both primary as well as secondary valences is shown by ----- solid-broken line
- Explanation of structure of Co(III) complexes on the basis of Werner's theory (**Figure 6.3**).

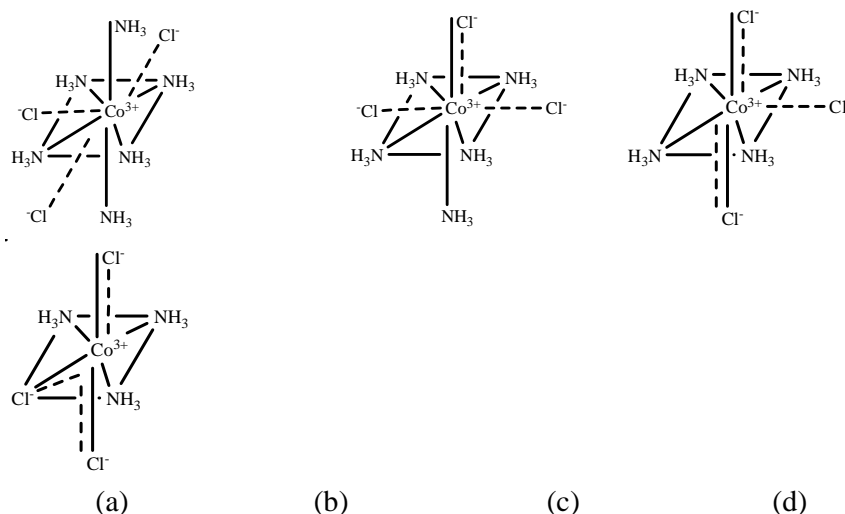
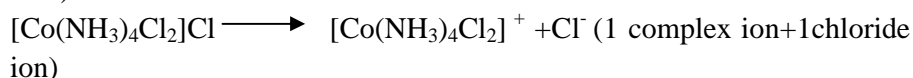
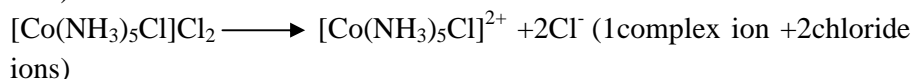
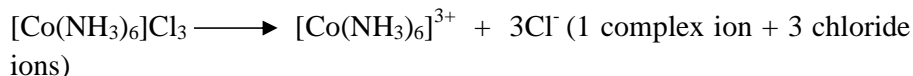

Figure 6.3 Structure of Co(III) amine complexes on the basis of Werner's theory. In all the complexes the primary valency of Co is 3 and secondary valency is 6. (a) $CoCl_3 \cdot 6NH_3$ $[Co(NH_3)_6]Cl_3$ (b) $CoCl_3 \cdot 5NH_3$ $[Co(NH_3)_5Cl]Cl_2$ (c) $CoCl_3 \cdot 4NH_3$ $[Co(NH_3)_4Cl_2]Cl$ (d) $CoCl_3 \cdot 3NH_3$ $[Co(NH_3)_3Cl_3]$

Werner's theory can be explained on the basis of experimental evidences

- Molar conductivity measurement method**

Compounds $[Co(NH_3)_6]Cl_3$, $[Co(NH_3)_5Cl]Cl_2$, $[Co(NH_3)_4Cl_2]Cl$ and $[Co(NH_3)_3Cl_3]$ show decreasing order of conductivity due to the formation of 4 ions, 3 ions, 2 ions and no ions, respectively in solution.



- **Precipitation method**

When cobalt ammine chloride complexes react with AgNO_3 , some of the Cl^- ions get precipitated with AgNO_3 to form AgCl . The number of Cl^- ions that are ionisable and present outside the coordination sphere can react with AgNO_3 . Thus, coordination compounds $[\text{Co}(\text{NH}_3)_6]\text{Cl}_3$, $[\text{Co}(\text{NH}_3)_5\text{Cl}]\text{Cl}_2$ and $[\text{Co}(\text{NH}_3)_4\text{Cl}_2]\text{Cl}$ react with 3, 2 and 1 mole of AgNO_3 to form 3, 2 and 1 mole of AgCl , respectively as there are 3, 2 and 1 ionisable Cl^- ions, respectively.

Defects of Werner's theory

- Although the theory describes the structure of many compounds, it can't explain the nature of bonding between metal atom/ion and ligands.
- Werner's theory was unable to explain why 4- and 6-coordination numbers are the preferred coordination numbers.

6.4 EFFECTIVE ATOMIC NUMBER CONCEPT (EAN CONCEPT)

This rule is given by English Chemist Nevil V. Sidgwick. Effective atomic number (EAN) is the total number of electrons in metal atom/ion (atomic number) plus the electrons gained from ligands. This EAN is the atomic number of a noble gas. Therefore, EAN decides stability of coordination compound. If a coordination compound follows EAN rule, then it is stable one.

$\text{EAN} = \text{Atomic number of metal atom/ion} + \text{number of } e^- \text{ donated by ligands or } 2 \times \text{number of ligands}$ (as each ligand can donate two electrons to metal atom/ion).

For $[\text{Co}(\text{NH}_3)_6]^{3+}$

Atomic number of $\text{Co} = 27$; Atomic number of $\text{Co}^{3+} = 24$; there are six ligands hence electrons donated by 6 ligands = 6×2

$$\text{EAN} = 24 + (6 \times 2) = 36 \text{ (atomic number of Krypton; Kr)}$$

For $[\text{Ni}(\text{CO})_4]$

Atomic number of $\text{Ni} = 28$; there are four ligands hence electrons donated by 4 ligands = 4×2

EAN = 28 + (4 x 2) = 36 (atomic number of Krypton; Kr)

For [Fe(CN)₆]⁴⁻

Atomic number of Fe=26; Atomic number of Fe²⁺=24; there are six ligands hence electrons donated 6 ligands = 6 x 2

EAN = 24 + (6 x 2) = 36 (atomic number of Krypton;

For [Ag(NH₃)₄]⁺

Atomic number of Ag=47; Atomic number of Ag⁺=46; there are four ligands, hence electrons donated by 4 ligands = 4 x 2

EAN = 46 + (4 x 2) = 54 (atomic number of Xenon; Xe)

= 54 (atomic number of Xenon; Xe)

For [V(CO)₆]⁻

Atomic number of V=23; Atomic number of V⁻ = 24; there are six ligands hence electrons donated 6 ligands = 6 x 2

EAN = 24 + (6 x 2)

= 36 (atomic number of Krypton; Kr)

For [Mn(CN)₄]²⁻

Atomic number of Mn=25; Atomic number of Mn²⁺ = 23; there are four ligands hence electrons donated 4 ligands = 4 x 2

EAN = 23 + (4 x 2)

= 31

Not obeying EAN rule as 31 is not the atomic number of any noble gas

6.5 CHELATE

A chelate is a stable coordination compound in which a metal atom/ion attached to ligand(s) with more than one donor site producing one or more ring (**Figure 6.4**). These compounds are also called as cyclic or chelated complexes and the formation of such rings is called as chelation or cyclisation. Classification of chelates depends upon the type and nature of chelating ligands such as bidentate chelates (with bidentate ligands), tridentate chelates (with tridentate ligands) etc

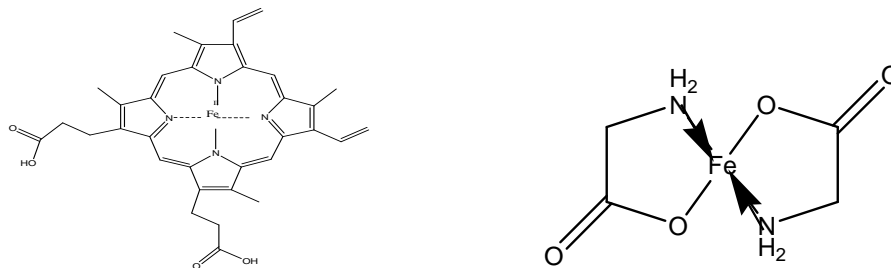

Figure 6.4: Chelates of iron

6.5.1 Applications of chelates:

Chelates are useful in water softening, medical and analytical chemistry and different industries such as chemical and food industry and agriculture.

In water softening:

Calcium (Ca^{2+}) and magnesium (Mg^{2+}) ions are responsible for hardening of water. These ions on reaction with soaps precipitate out. In the presence of chelating ligands such as polyphosphates and polydentate amino acids, no precipitation occurs as these ions form chelate complexes with polyphosphate and polydentate ligands present in soap and thus, soften water.

In food industry:

Metal-amino acid chelates are helpful in enhancing mineral absorption such as Ferrous bis-glycinate. Chelates are also used to preserve fruits, fruit juices, food stuffs etc.

In agriculture:

Metal chelates are used as common components of fertilizers in agriculture. Micronutrients such as manganese, iron, zinc and copper are required for the overall health of the plants. These micronutrients along with EDTA form chelate fertilizers. Presence of chelates enhance uptake of micronutrients by the plants. Chelating ligands are also used to detoxify poisonous metal such as mercury, arsenic and lead present in polluted water.

In medical field:

Tetracycline and quinolone can form chelate with Fe^{2+} , Ca^{2+} and Mg^{2+} ions and thus, these chelates can be used as supplements of these ions. As EDTA softens the dentin, it is used in root canal treatment as an intracanal irritant. Chelates

of gadolinium are used as contrast agents in MRI scans. Metal poisoning can be decreased by chelation with EDTA as toxic metals such as mercury, arsenic, lead and other radioactive metals can be excreted without further interaction with the body by converting them into chemically inert form (EDTA metal complex). Chelation is also used in the treatment for autism.

Chemical applications:

Homogeneous catalyst such as ruthenium(II) chloride chelated with BINAP (a bidentate phosphine) is used in Noyori asymmetric hydrogenation and asymmetric isomerisation for the manufacture of synthetic (-)-menthol. Bio-Rust and Evapo-Rust are chelating agents used for the removal of rust from iron and steel. Metal chelates are also used in dyeing industry.

Physiological chemistry (in human body):

In body fluids, citric, malic and tartaric acids, the natural chelating agents, keep the metal ions away from precipitation. The other physiologically important chelates are haemoglobin, vitamin B₁₂, chlorophyll, cytochrome and plastocyanine

6.5.2 Stability of chelates:

Stability of chelates can be explained on the basis of standard free energy change (ΔG°), standard entropy change (ΔS°), steric effect, size of ring and number of rings.

- **Change in thermodynamic variables:**

Consider formation of coordination compounds of cadmium with monodentate and bidentate ligands, e.g.,

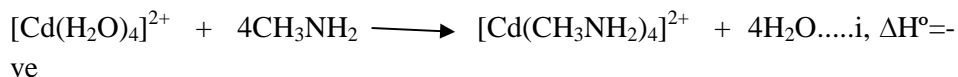

	Monodentate ligand	Non-chelated compound	
1 molecule	4 molecules	1 molecule	4 molecules

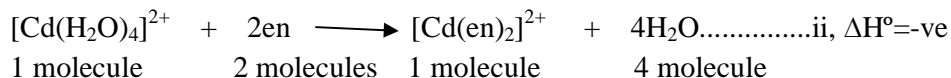

1 molecule	2 molecules	1 molecule	4 molecule
	Bidentate ligand	Chelated compound	

Stability of the product in a chemical reaction can be explained by the following reaction:

$$\Delta G^\circ = (\Delta H^\circ) - (T\Delta S^\circ) \quad \text{where } \Delta H^\circ \text{ is change in enthalpy and } T \text{ is temperature}$$

You already know that a product will be stable if value of ΔG° is negative (-ve) and value of ΔS° is positive (+ve).

During the formation of a nonchelated compound with monodentate ligands (i), the number of molecules on both side is equal (5 molecules each side), hence ΔS° will be zero and the value of ΔG° will be negative.

With bidentate ligand (ii), number of product molecules (5 molecules) is greater than the number of reactant molecules (3 molecules). Hence, entropy of product is greater than reactants and thus, ΔS° will be positive and value of ΔG° will become more negative. Thus, it may be concluded that ΔG° has more negative value for chelates which are formed by the reaction of bidentate or other polydentate ligands and therefore, are more stable as compared to the nonchelated compounds.

- **Steric effect:**

When a group is present on the donor atom or near the donor atom of a ligand, the metal ligand bonds becomes weak and thus, lower the stability of that compound. This effect is known as steric effect or steric hindrance. Among complex compounds I and II, compound II will be more stable as in compound I, there is one methyl group near the donor atom N which causes steric effect.

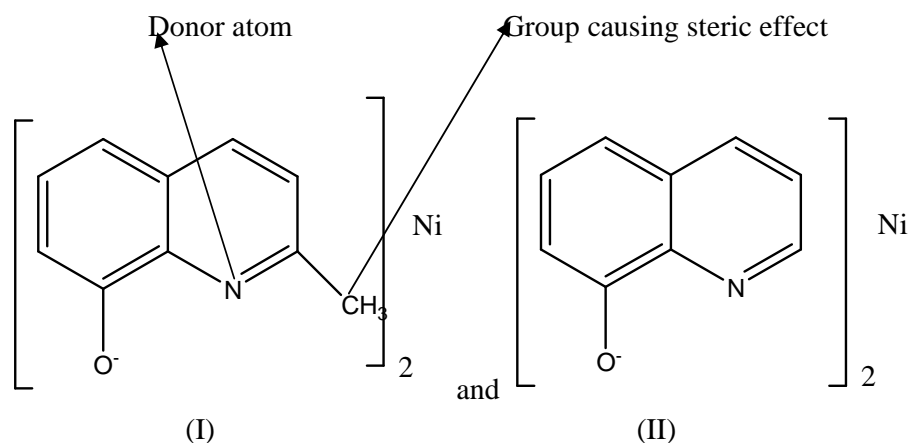

- **Size of chelate ring:**

Chelate ring having 5-members give stable compounds and chelate rings having more or less than 5-members are generally less stable. This happens because the stability constant for 5-membered chelate is the highest.

- **Number of rings:**

Greater the number of rings, more will be the stability of chelate. As the number of donor atoms in a chelating ligand increases, stability increase due to the increase in the number of chelate rings.

Stability order of the chelates with the bi- and tridentate ligands.

en (number of rings=1) < trien (number of rings = 3)

6.6 NOMENCLATURE OF COORDINATION COMPOUNDS

The coordination compounds are named according to the following steps suggested by IUPAC (International Union of Pure and Applied Chemistry) (**Figure 6.5**).

Step I: Naming of ions

- The positively charged metal ion is written first followed by the negative ions in **ionic compounds**.
 - FeCl₂ : Iron (II) chloride
 - KCl : Potassium (I) chloride
- Name of **non-ionic or molecular complexes** are written as one word without any gap.
 - K₄[Fe(CN)₆]: Potassium (**positive ion**) hexacyano(ligand)ferrate (**central ion**)(III) (non ionic compound)
 - [Pt(NH₃)₄]⁴⁺: Tetraammineplatinum (IV)

The name in red is one word without any gap as it is a complex ion.

Step II: Naming coordination sphere

In case of the complex ion (coordination sphere), name of ligands written first than only central metal atom/ion along with its oxidation number in parenthesis should be written.

[Ni(CO)₄] - Tetracarbonylnickel(0)

[Pt(NH₃)₄]⁴⁺ - Tetraammineplatinum(IV)

Ending of name: If the complex is anionic, the suffix **ate** is added to the name of metal along with oxidation state in parenthesis.

K₂[HgCl₄] Potassium tetrachloridomercurate(II)

Step III: At the last, the name of anion which is present on the outside of the coordination sphere should be written, e.g.,

[Pt(NH₃)₄]Cl₄ - Tetraammineplatinum(IV) **chloride**

[Co(NH₃)₆]Cl₃ - Hexaamminecobalt(III) **chloride**

Names of some common ligands

Ligands are named alphabetically along with a prefix (di, tri, tetra, penta etc for simple ligands and bis, tris, tetrakis etc. for complicated ligands) of their number. Some of the common ligands are given in **Table 6.3**.

Table 6.3: Name and abbreviation of ligands

Type of ligands	Category of ligand	Formula	Name
Simple ligands	Neutral (written as a neutral molecule)	H ₂ O	Aqua
		NH ₃	Ammine
		CO	Carbonyl
		NO	Nitrosyl
	Anionic (-o at the end of ligand's name)	F ⁻	fluorido
		Cl ⁻	chlorido
		Br ⁻	bromido
		I ⁻	iodido
		OH ⁻	hydroxido
		CN ⁻	cyanido
		C ₂ O ₄ ²⁻	oxalato
		NO ₃ ⁻	nitrato
		CO ₃ ²⁻	carbonato
		NH ₂ ⁻	amido
		H ⁻	hydrido
		NO ₂ ⁻	nitrito-N
		ONO ⁻	nitrito-O
		O ²⁻	oxido
		O ₂ ²⁻	peroxido
		N ₃ ⁻	azido
		S ²⁻	sulphido
		C ₆ H ₅ ⁻	phenyl
		NH ₂ ⁻	amido
		NH ²⁻	imido
		C ₅ H ₅ ⁻	cyclopentadienyl
			Cationic (-ium at the end of ligand's name)
NO ₂ ⁺	nitronium		
Complicated ligands with abbreviation	en	C ₂ H ₈ N ₂	ethylenediamine
	py	C ₅ H ₅ N	pyridine
	ox	C ₂ O ₄ ²⁻	oxalato
	dmsO	(CH ₃) ₂ SO	dimethyl sulfoxide
	EDTA	C ₈ H ₁₂ N ₂ O ₈ ⁴⁻	ethylenediamine tetraacetato
	gly	NH ₂ CH ₂ CO ₂ ⁻	glycinato
	oxine	C ₉ H ₇ NO	8-hydroxyquinolinato

	phen	C ₁₂ H ₈ N ₂	1,10-phenanthroline
	dmg	C ₄ H ₇ N ₂ O ₂	dimethylglyoximate
	ur	NH ₂ CONH ₂	urea
	tu	H ₂ NCSNH ₂	Thiourea

Naming of bridging complexes

The bridging groups in the complexes are written first with a prefix μ by separating it from the complex by hyphen (-). This μ is used every time for each bridging ligand. Thereafter, the other ligands with number prefix (di, tri or bis-, tris- etc.), metal with oxidation state in bracket and at last the negative species outside the coordination sphere.

Type of complex/ compound		Formula of compound	Name of compound
Simple (one ion is complex and other simple ion)	Complexes with neutral coordination sphere	[Ni(CO) ₄]	Tetracarbonylnickel(0)
		[Fe(C ₅ H ₅) ₂]	Bis(cyclopentadienyl)iron (II)
		[Pt(en) ₂ Cl ₂]	Dichlorobis(ethylenediamine)platinum(II)
		[Hg(CH ₃) ₂]	Dimethylmercury(II)
		[Mn ₃ (CO) ₁₂]	Dodecacarbonyltrimanganese (0)
		[Ni(PF ₃) ₄]	Tetrakis(trifluorophosphine)nickel(0)
	Complexes with anionic coordination sphere	K ₂ [HgCl ₄]	Potassium tetrachloromercurate(II)
		K ₄ [Cu(CN) ₆]	Potassium hexacyanocuprate(II)
		Na ₃ [Co(NO ₂) ₆]	Sodium hexanitrito-Ncobaltate(III)
		K ₂ [Fe(CN) ₅ NO]	Potassium pentacyanonitrosylferrate(III)
		Na[Au(CN) ₂]	Sodium dicyanoaurate(I)
		K ₃ [Cr(CN) ₆]	Potassium hexacyanochromate(III)
		K ₄ [Ni(CN) ₄]	Potassium tetracyanonickelate(0)
		Na ₃ [Fe(C ₂ O ₄) ₃]	Sodium trioxalatoferrate(III)
		Fe[Fe(CN) ₆]	Iron hexacyanoferrate(III)
		K ₄ [Fe(CN) ₆]	Potassium hexacyanoferrate(II)
		K ₃ [Fe(CN) ₆]	Potassium hexacyanoferrate(III)
		Na ₂ [ZnCl ₄]	Sodium tetrachlorozincate(II)
		[Cr(C ₂ O ₄) ₃] ³⁻	Trioxalatochromate(III)
		[Co(N ₃)(NH ₃) ₅][SO ₄]	Pentaammineazidocobalt(III) sulphate
[Cr(H ₂ O) ₆]Cl ₃	Hexaaquachromium(III) chloride		
[Cr(NH ₃) ₆] ³⁺	Hexaammine chromium(III) ion		
[Cr(H ₂ O) ₄ Cl ₂][NO ₃]	Tetraaquadichlorochromium(III) nitrate		

	Complexes with cationic coordination sphere		
		$[\text{Cu}(\text{NH}_3)_2(\text{en})]\text{Br}_2$	Diammine(ethylenediamine)copper(II) bromide
		$[\text{PtClBr}(\text{NH}_3)\text{py}]$	Amminebromochloropyridineplatinum(II)
		$[\text{CuCl}_2(\text{CH}_3\text{NH}_2)_2]$ Complex ligand	Dichlorobis(methylamine)copper(II) ion
		$[\text{Co}(\text{NH}_3)_5\text{ONO}]\text{SO}_4$	Pentaamminenitritocobalt(III) sulphate
		$[\text{Co}(\text{NH}_3)_2(\text{H}_2\text{O})_2(\text{CN})_2]\text{Cl}$	Diamminediaquadicyanocobalt(III) chloride
		$[\text{Cr}(\text{NH}_3)_2(\text{H}_2\text{O})_3(\text{OH})](\text{NO}_3)_2$	Diamminetriaquahydroxochromium(III) nitrate
	Both cation and anion are complex	$[\text{Pt}(\text{NH}_3)_4][\text{PtCl}_4]$ (Firstly complex cation is named then only the complex anion)	Tetraammineplatinum(II) tetrachloroplatinate(II)
		$[\text{Cr}(\text{NH}_3)_5(\text{NCS})][\text{ZnCl}_4]$	Pentaammineisothiocyanatochromium(III) tetrachlorozincate(II)
	Bridging complex ????	$\left[\left(\text{NH}_3 \right)_4 \text{Fe} \begin{array}{c} \text{OH} \\ \diagup \quad \diagdown \\ \text{Fe} \end{array} \left(\text{NH}_3 \right)_4 \right] \left(\text{SO}_4 \right)_2$?????	Octaaqua- μ -dihydroxo-diiron(III) sulphate or Tetraammineiron(III)- μ -dihydroxo-tetraammineiron(III) or μ -dihydroxo-octaaquadiiron(III) sulphate or μ -Hydroxo-tetraaquairon(III) μ -hydroxo-tetraaquairon(III) sulphate
		$\left[\left(\text{NH}_3 \right)_4 \text{Co} \begin{array}{c} \text{OH} \\ \diagup \quad \diagdown \\ \text{Co} \end{array} \left(\text{NH}_3 \right)_4 \right] \left(\text{NO}_3 \right)_4$	μ -Dihydroxo-octaaamminedicobalt(III) nitrate
		$\left[\left(\text{en} \right)_2 \text{Co} \begin{array}{c} \text{NH}_2 \\ \diagup \quad \diagdown \\ \text{Co} \end{array} \left(\text{en} \right)_2 \right] \text{Cl}_3$	μ -Amido- μ -hydroxo-tetrakis(ethylenediamine)dicobalt(III) sulphate

Calculation of oxidation number of metal atom/ion

In coordination compound, $[M(L)_n]^{\pm}$ or $[M(L)_n]$, oxidation state of M can be calculated as Oxidation number of M + Oxidation number of L x n = \pm or 0

For example,

1) Oxidation number (ON) of Co in $[\text{Co}(\text{NH}_3)_6]^{3+}$

ON of Co + 0 (ON of NH_3 is 0) = +3

Hence, ON of Co will be +3.

2) Oxidation number (ON) of Ni in $[\text{Ni}(\text{CO})_4]$

ON of Ni + 0 (ON of CO is 0) = 0

Hence, ON of Ni will be 0.

6.7 SUMMARY

In this Unit, you have studied the following:

- Simple or double salts dissociate into their constituent ions while coordination compounds break up into complex ion and its counter charged ion.
- Coordination compounds comprise of two main parts; central metal atom/ion and ligands coordinated to the metal atom/ion.

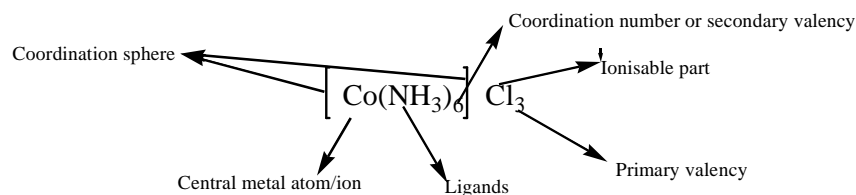

- A wide variety of ligands including monodentate, polydentate, sigma donor, chelating, macrocyclic, actor and spectator ligands are involved in the formation of coordination compounds with metal atom/ion.
- Monodentate ligands can donate a pair of electrons to a central metal atom while a polydentate ligand can donate more than one pair of electrons to the metal atom/ion. Bidentate or polydentate ligands form cyclic compounds called chelates.
- Coordination compounds have various applications in different industries.
- Werner suggested that coordination number and oxidation number of metal depends on the nature of the metal.
- EAN rule decides the stability of a coordination compound.
- Nomenclature of coordination compounds is systematic.

6.8 DEFINITIONS

Chelate: Chelate is a compound containing a ligand (typically organic) bonded to a central metal atom at two or more points.

Complex ion: A complex ion is an ion formed by the coordination of central metal ion with one or more ligands.

Coordination compound: A compound in which a central atom/ion is bonded to a definite number of ligands.

Coordination number: It is the number of ligands surrounding the central metal ion.

Effective Atomic Number: It is the sum of the electrons of metal atom/ion and electrons donated by ligand.

Ligand- Ligand is a charged or neutral molecule which can donate electron pair to the metal atom to form a coordination compound.

Primary valency: Primary valency in a coordination compound is the number of negative ions that satisfy the positive charge on the central metal ion.

Secondary valency: Secondary valency in a coordination compound is defined as the number of ligands that are coordinated to the central metal ion. It is equal to the coordination number.

6.9 QUESTIONS

6.9.1 Short answer questions

1. Which of the following ligands are weak or strong?
 CN^- , CO , H_2O , NH_3
2. Classify the following ligands as pi acceptor or sigma donor ligands.
 NO , Cl^- , NH_3 , benzene
3. Give two examples of each neutral and positive monodentate ligands.
4. What is chelate effect?
5. Select monodentate and polydentate ligands among the following:
 NCS^- , NH_3 , $\text{C}_2\text{O}_4^{2-}$, EDTA, en, Cl^-
6. Draw the structures of the following ligands:
EDTA, dmg, porphyrin, 8-quinoline, diethylenetriamine
7. Explain spectator ligand.
8. How chelates are useful?
9. What do you mean by complex ion?
10. Calculate oxidation state and coordination number of Fe in $[\text{Fe}(\text{CN})_6]^{4-}$ and $[\text{Fe}(\text{C}_2\text{O}_4)_3]^{3-}$?
11. Draw the geometry that describe five and six-coordinate compounds. Which structures are more common?
12. Give the geometry of the following compounds:

- (i) $[\text{Co}(\text{NH}_3)_6]^{3+}$
 (ii) $[\text{Ag}(\text{NH}_3)_2]^+$
 (iii) $[\text{Fe}(\text{CN})_6]^{4-}$
 (iv) $[\text{Fe}(\text{C}_2\text{O}_4)_3]^{3-}$
13. Define coordination sphere.
 14. What is primary valency?
 15. What do you mean by secondary valency?
 16. On the basis of Werner's theory, draw the structure of $\text{CoCl}_3 \cdot 6\text{NH}_3$ and $\text{CoCl}_3 \cdot 5\text{NH}_3$.
 17. Name the experimental methods to explain Werner's theory?
 18. Define EAN rule.
 19. Who gave the concept of EAN rule?
 20. Calculate EAN for $[\text{Ni}(\text{CO})_4]$.
 21. Calculate the oxidation number of the metal atom/ ion in the following coordination complexes:
 - a) $[\text{CoCl}_4]^{2-}$
 - b) $[\text{Fe}(\text{CN})_6]^{3-}$
 - c) $[\text{Ni}(\text{CO})_4]$
 - d) $[\text{Cr}(\text{CO})_6]$
 22. Name the following ligands:
 Cl^- , H^+ , NO^+ , H_2O , NO_3^- , ONO^- , NH_2^- , C_5H_5^-
 23. Write down the abbreviation and formula of the following ligands:
 ethylenedimmine, dimethyl sulphoxide, glycine, urea, 1,10-phenanthroline, ethylenediammine tetraacetic acid.
 24. Name the following coordination compounds:
 - a. $\text{Na}_3[\text{Co}(\text{NO}_2)_6]$
 - b. $\text{K}_4[\text{Ni}(\text{CN})_4]$
 - c. $[\text{Mn}_3(\text{CO})_{12}]$
 - d. $\text{K}_3[\text{Fe}(\text{CN})_6]$
 - e. $[\text{Pt}(\text{NH}_3)_4][\text{PtCl}_4]$
 - f.
$$\left[\left(\text{NH}_3 \right)_4 \text{Co} \begin{array}{c} \text{OH} \\ \diagup \quad \diagdown \\ \text{Co} \end{array} \left(\text{NH}_3 \right)_4 \right] \left(\text{NO} \right)_4$$
 25. Write down the formula of hexamminecobalt (III) chloride and tetracarbonyl nickel (0).
 26. Draw the structure of the following complexes:
 - a) Sodium hexafluorosilicate (IV)
 - b) Ammonium diamminetetra(isothiocyanato)chromate(III)
 27. How does the conductivity of $[\text{Co}(\text{NH}_3)_6]\text{Cl}_3$ and $[\text{Co}(\text{NH}_3)_5\text{Cl}]\text{Cl}_2$ differ from each other?
 28. Write the formula of the following compounds:
 - a) Octaammine- μ -amido- μ -nitridocobalt(III) nitrate
 - b) Dichlorobis(ethylenediamine)cobalt(III) chloride

- c) Hexaquaairon(II) sulphate
 d) Tetrachloroplatinate(II)
29. Which of the following complexes follow EAN rule? Give electron count in each case.
- a) $[\text{Cr}(\text{NH}_3)_6]^{3+}$
 b) $[\text{Ni}(\text{NH}_3)_6]^{2+}$
 c) $[\text{Cr}(\text{CO})_6]$
 d) $[\text{Mn}(\text{CN})_6]^{4-}$
 e) $[\text{Fe}(\text{H}_2\text{O})_6]^{2+}$
 f) $[\text{Fe}(\text{CN})_6]^{4+}$
 g) $[\text{Fe}(\text{CN})_6]^{3-}$
30. Explain the meaning of the terms monodentate, bidentate and tetradentate.
31. Arrange the following complexes in the increasing order of molar conductivity:
 a) $[\text{Co}(\text{NH}_3)_6]\text{Cl}_3$ b) $[\text{Co}(\text{NH}_3)_5\text{Cl}]\text{Cl}_2$ c) $[\text{Co}(\text{NH}_3)_3\text{Cl}_3]$

6.9.2 True (T) or False (F)

- a) CO and NO are pi acceptor ligands.
 b) Monodentate ligands are of three types: neutral, negative and positive
 c) Ethylenediammine is a monodentate ligand.
 d) Monodentate ligands form more stable compounds as compared to polydentate ligands.
 e) Spectator ligands are those ligands that take part in a chemical reaction.
 f) Coordination number is also known as secondary valency.
 g) Coordination number does not decide the geometry of coordination compound.
 h) Octahedral and trigonal prismatic geometries are found in 6 coordinated compounds.
 i) Chelates are the cyclic compounds.
 j) More positive the value of ΔG° , more stable the chelate.
 k) Primary valency is the oxidation number or the group valency of the metal atom/ion.
 l) The attachment of species that satisfy both primary as well as secondary valences is shown by ----- broken line.
 m) Complex $[\text{Co}(\text{NH}_3)_3\text{Cl}_3]$ will ionize to give two ions.
 n) Complex $[\text{Co}(\text{NH}_3)_5\text{Cl}]\text{Cl}_2$ will react with three molecules of AgNO_3 .
 o) EAN stands for Effective Atomic Nuclei.
 p) Abbreviation for glycine is gly.
 q) IUPAC name of $[\text{Cr}(\text{NH}_3)_6]^{3+}$ complex is hexaamminechromate (III).
 r) Formula of the compound Tetrachloroplatinate (II) is $[\text{PtCl}_4]^{2-}$.

6.10 LONG ANSWER QUESTIONS

- What is the difference between chelating and macrocyclic ligands? Explain with the help of examples.
- What are chelates? How are they important? Give examples.
- Define ligand. Give detailed account on the classification of ligands.
- How are the coordination compounds named? Describe with the help of examples?
- What is EAN rule? Give details with examples.
- Explain Werner's theory.
- What do you mean by coordination number? How is it useful in deciding the geometry of coordination compounds? Explain with the help of examples.
- What are primary and secondary valencies? Explain by giving suitable examples.
- Discuss the basic postulates of Werner's theory of coordination compounds. Explain structure of $\text{CoCl}_3 \cdot 6\text{NH}_3$, $\text{CoCl}_3 \cdot 5\text{NH}_3$, $\text{CoCl}_3 \cdot 4\text{NH}_3$, $\text{CoCl}_3 \cdot 3\text{NH}_3$ on the basis of Werner's theory.
- Explain in detail about the stability of chelates.

6.11 ANSWERS TO SHORT ANSWER QUESTIONS

Short answer questions:

- Weak ligands- H_2O , NH_3 ; strong ligands - CN^- , CO
- π acceptor ligands- NO , C_6H_6 ; sigma donor ligands- Cl^- , NH_3
- Neutral monodentate ligands- NH_3 , H_2O ; positive monodentate ligands- NO^+ , NH_2NH_3^+ .
- Chelating ligands are those ligands that bind via more than one atom and form chelate complexes (ring complexes). These complexes are more stable than complexes formed from monodentate ligands. The enhanced stability is known as the chelate effect.
- Monodentate ligands: NCS^- , NH_3 , Cl^- ; Polydentate ligands- $\text{C}_2\text{O}_4^{2-}$, EDTA, en.
- EDTA:

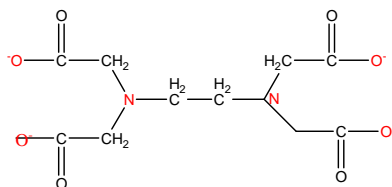

dmg:

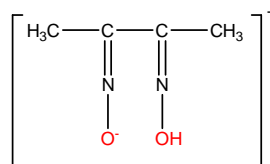

porphyrin:

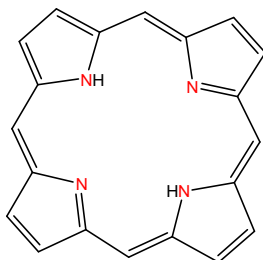

8-hydroxyquinoline:

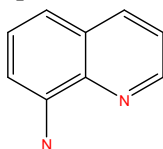

diethylene triamine:

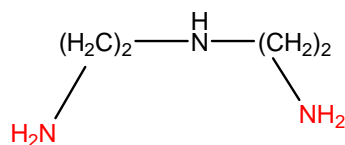

7. Spectator ligand, a tightly coordinating polydentate ligand that does not take part in a chemical reaction.
8. Chelates are useful in water softening, medical and analytical chemistry and different industries such as agriculture, chemical and food.
9. A complex ion is an ion in which the metal ion presents at the centre and a definite number of ligands surround it. The complex ion is enclosed in a large bracket.
10. Oxidation state and coordination number of Fe in $[\text{Fe}(\text{CN})_6]^{4-}$ is +2 and six while in $[\text{Fe}(\text{C}_2\text{O}_4)_3]^{3-}$ is +3 and six, respectively.
11. Geometry that describes five coordinated compounds:
 Trigonal bipyramidal and Square pyramidal; Trigonal bipyramidal is the most stable geometry.
 Geometry that describes six coordinated compounds.
 Octahedral and Trigonal prismatic; Octahedral is the most stable geometry.
12.
 - (i) Octahedral
 - (ii) Linear
 - (iii) Octahedral
 - (iv) Octahedral
13. The coordination sphere of a coordination compound comprises the central metal atom/ion and ligands attached to it. The coordination sphere is enclosed in brackets [].

14. Primary valency is the oxidation number or the group valency of the metal atom/ion, for example +2 for copper (Cu).
15. Secondary valency is the coordination number or the number of ligands coordinated to the metal atom/ion such as 6 for cobalt (Co).
16. $\text{CoCl}_3 \cdot 6\text{NH}_3$ $\text{CoCl}_3 \cdot 5\text{NH}_3$

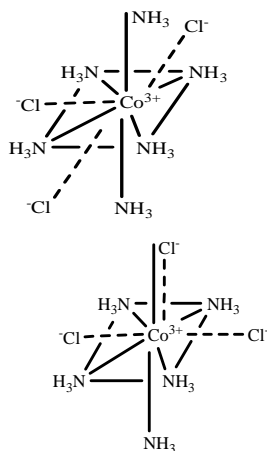

17. Molar conductivity measurement method and precipitation method.
18. Effective atomic number (EAN) is the total number of electrons in metal atom/ion (atomic number) plus the electrons gained from ligands. This EAN is the atomic number of a noble gas. Therefore, EAN decides stability of coordination compound. If a coordination compound follows EAN rule, then it is stable one.
19. English Chemist Nevil V. Sidgwick gave the concept of EAN rule.
20. EAN for $[\text{Ni}(\text{CO})_4]$

Atomic number of Ni=28; there are four ligands hence electrons donated by 4 ligands = $4 \times 2 = 8$

$$\text{EAN} = 28 + 8$$

$$= 36 \text{ (atomic number of Krypton; Kr)}$$

21. Oxidation number of the metal in the following coordination complexes:
- +2
 - +3
 - 0
 - 0
22. Cl^- = chloro; H^- = hydrido; NO^+ = nitrosonium; H_2O = aqua; NO_3^- = nitrate; ONO^- = nitrito-N; NH_2^- = amido; C_5H_5^- = cyclopentadienyl.
23. ethylenedimmine = en; dimethyl sulphoxide = dms; glycine = gly; urea = ur; 1,10-phenanthroline = phen; ethylenediammine tetraacetic acid = EDTA.
24. a. $\text{Na}_3[\text{Co}(\text{NO}_2)_6]$ = Sodium hexanitrito-N cobaltate (III)
 b. $\text{K}_4[\text{Ni}(\text{CN})_4]$ = Potassium tetracyanonickelate (0)

- c. $[\text{Mn}_3(\text{CO})_{12}]$ = Dodecacarbonyltrimanganese (0)
 d. $\text{K}_3[\text{Fe}(\text{CN})_6]$ = Potassium hexacyanoferrate (III)
 e. $[\text{Pt}(\text{NH}_3)_4][\text{PtCl}_4]$ = Tetraammineplatinum(II) tetrachloroplatinate

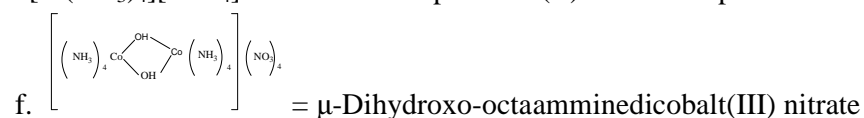

25. Hexamminecobalt(III) chloride = $[\text{Co}(\text{NH}_3)_6]\text{Cl}_3$
 tetracarbonylnickel(0) = $[\text{Ni}(\text{CO})_4]$
26. a) $\text{Na}_2[\text{SiF}_6]$
 b) $\text{NH}_4[\text{Cr}(\text{NH}_3)_2(\text{NCS})_4]\text{CrO}_4$
27. Compounds $[\text{Co}(\text{NH}_3)_6]\text{Cl}_3$ and $[\text{Co}(\text{NH}_3)_5\text{Cl}]\text{Cl}_2$ show decreasing order of conductivity due to the formation of 4 ions and 3 ions, respectively in solution.
28.
 a.
- $$\left[\left(\text{NH}_3 \right)_4 \text{Co} \begin{array}{c} \text{NH}_2 \\ \diagup \quad \diagdown \\ \text{Co} \\ \diagdown \quad \diagup \\ \text{NO}_2 \end{array} \left(\text{NH}_3 \right)_4 \right] \left(\text{NO}_3 \right)_4$$
- b. $[\text{Co}(\text{en})_2\text{Cl}_2]\text{Cl}$
 c. $[\text{Fe}(\text{H}_2\text{O})_6]\text{SO}_4$
 d. $[\text{PtCl}_4]^{2-}$
29.
 a. EAN = 37 (not follow EAN rule)
 b. EAN = 38 (not follow EAN rule)
 c. EAN = 36 (follow EAN rule)
 d. EAN = 35 (not follow EAN rule)
 e. EAN = 36 (follow EAN rule)
 f. EAN = 36 (follow EAN rule)
 g. EAN = 35 (not follow EAN rule)
30. The ligands that bound to a metal ion through a single donor atom; two donor atoms and four donor atoms are called as monodentate, bidentate and tetradentate ligands, respectively.
31. c) $[\text{Co}(\text{NH}_3)_3\text{Cl}_3]$ b) $[\text{Co}(\text{NH}_3)_5\text{Cl}]\text{Cl}_2$ a) $[\text{Co}(\text{NH}_3)_6]\text{Cl}_3$

True (T) or False (F)

- a. T
 b. T
 c. F
 d. F
 e. F
 f. T
 g. F
 h. T

- i. T
- j. F
- k. T
- l. F
- m. F
- n. F
- o. F
- p. T
- q. F
- r. T

6.12 BIBLIOGRAPHY

- a) B. R. Puri, L. R. Sharma and K. C Kalia, *Principles of Inorganic Chemistry*, Milestone Publishers & Distributors, Meerut, 2013.
- b) [file://localhost/H:/coordination%20coordination%20cheemistry/Coordination %20 Chemistry.htm](file://localhost/H:/coordination%20coordination%20cheemistry/Coordination%20Chemistry.htm)
- c) G. S. Sodhi, *Textbook of Inorganic Chemistry*, Viva Books Private Limited, New Delhi, 2013.
- d) <http://www.rsc.org/pdf/tct/df-chapter.pdf>
- e) http://www.trentu.ca/chemistry/chem321h/lectures/lecture321coordination_compounds.pdf
- f) <https://www.wou.edu/las/physci/ch412/ligand.htm>
- g) M. S. Yadav. *Quick Review in Inorganic Chemistry*, Anmol Publications Pvt. Ltd., New Delhi, 2004.
- h) P. Mishra *Advanced Inorganic Chemistry*, Jagdamba Publishing Compan, New Delhi, 2011.
- i) R. Gopalan, and V. Ramalingam. *Concise Coordination Chemistry*, Vikas Publishing House Pvt Ltd., New Delhi, 2005.
- j) R. L. Madan, *Chemistry for degree students, B.Sc. II year*, S. Chand & Company Ltd., New Delhi, 2011.
- k) S. Prakash, G. D. Tuli, S. K. Basu, and R. D. Madan. *Advanced Inorganic Chemistry*, Vol. II, S. Chand & Company Ltd., New Delhi, 2007.
- l) W. U. Malik, G. D. Tuli, and R. D. Madan. *Selected Topics in Inorganic Chemistry*, S. Chand Publication, Delhi, 2013.

UNIT 7-ISOMERISM OF COORDINATION COMPOUNDS

CONTENTS:

- 7.1 Objectives
- 7.2 Introduction
- 7.3 Isomerism in coordination compounds
 - 7.3.1 Structural isomerism
 - 7.3.1.1 Linkage isomerism
 - 7.3.1.2 Ionization isomerism
 - 7.3.1.3 Coordination isomerism

- 7.3.1.4 Hydrate isomerism
- 7.3.1.5 Ligand isomerism
- 7.3.1.6 Coordination position isomerism
- 7.3.2 Methods for identification of structural isomers
- 7.3.3 Stereoisomerism
 - 7.3.3.1 Geometrical isomerism
 - 7.3.3.1.1 Four-coordinated compounds
 - 7.3.3.1.2 Six-coordinated compounds
 - 7.3.3.2 Optical isomerism
 - 7.3.3.2.1 Four-coordinated compounds
 - 7.3.3.2.2 Six-coordinated compounds
 - 7.3.3.3 Importance of stereoisomerism
 - 7.3.3.4 Methods for identification of stereoisomers
- 7.4 Valence bond theory of transition metal complex
- 7.5 Summary
- 7.6 Definitions
- 7.7 Questions for practice
 - 7.6.1 True or false
 - 7.6.2 Fill in the blanks
 - 7.6.3 Short answer questions
- 7.8 Bibliography
- 7.9 Long answer questions
- 7.10 Answers

7.1 OBJECTIVES

At the end of this unit, you will be able to describe with the following:

- Isomerism
- Isomer
- *Cis* isomer
- *Trans* isomer
- Enantiomer
- Chirality
- Structural isomers
- Laevorotatory (*l*)
- Dextrorotatory (*d*)
- Geometrical isomerism
- Optical isomerism

And also gain the knowledge of:

- The types of isomerism possible in coordination compounds
- Importance of isomerism

7.2 INTRODUCTION

The objectives of this unit are to familiarize you with the isomerism in coordination compounds and its types. The coordination compounds which have the same chemical formula but different ways of attachment of ligands are called as isomers. These isomers have different physical and chemical properties. The phenomenon that gives rise to the isomers is known as isomerism. There are two main types of isomerism in coordination compounds; structural and stereoisomerism. Our focus will be on both structural isomerism and stereoisomerism. Structural isomerism is due to the different bond arrangement of atoms in coordination compound around the central metal atom/ ion while stereoisomerism arises due to different three-dimensional arrangement of atoms in space.

7.3 Isomerism in coordination compounds

The coordination compounds having the same molecular formula but different arrangement of atoms/ groups around the central metal/ ion are called isomers and the phenomenon which gives rise to isomers is called as isomerism. The isomers have different physical and chemical properties. There are two main types of isomerism: (1) Structural isomerism and; (2) Stereoisomerism. These can be further sub-divided into several types. Various types of isomerism exhibited by coordination compounds are shown in Figure 7.1.

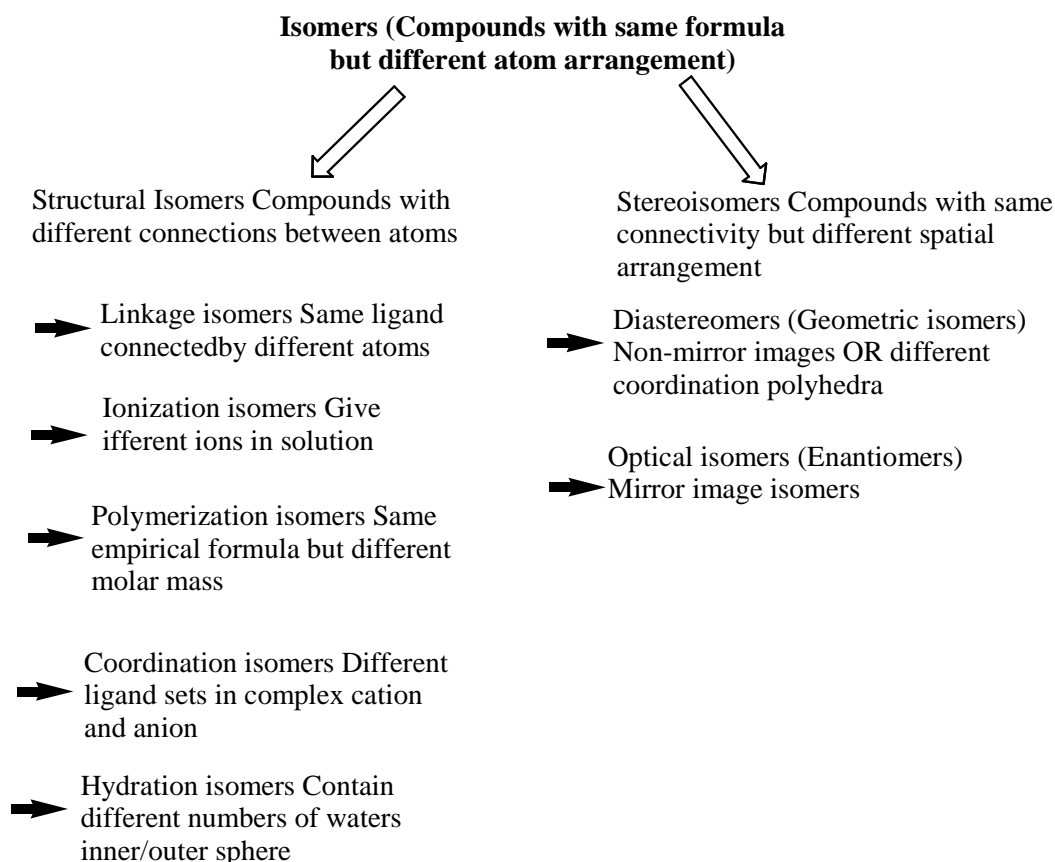

Figure 7.1: Types of isomerism in coordination compounds

7.3.1. Structural Isomerism

Structural isomerism is also known as **constitutional isomerism**. The molecules have same number of atoms which differ in their structure or bonding. The different chemical formulae of structural isomers are either due to difference in ligands that are bonded to the central atoms or the mode of bonding of individual ligand (which atom of the ligand is bonded to the central atom). Now we will discuss the various types of structural isomerisms one by one in brief.

7.3.1.1 Linkage Isomerism

Complexes having **ambidentate ligands** like $\text{SCN}^- / \text{NCS}^-$, $\text{CN}^- / \text{NC}^-$ and $\text{NO}_2^- / \text{ONO}^-$ (capable of coordinating in more than one way) show **linkage isomerism**. The two isomers differ from each other by the linkage atom attachment to the central atom/ion. The ligand can have more than two donor atoms but should be joined to the central atom/ion via only one atom (unidentate ligand). The formula of the compound is same but their properties are entirely different. The name of the ligands is also changed according to their donor atom. When **donor atom is N**, NO_2^- is called as **nitro**, while it is called **nitrito** if the **donor atom is O** atom (**Figure 7.2**).

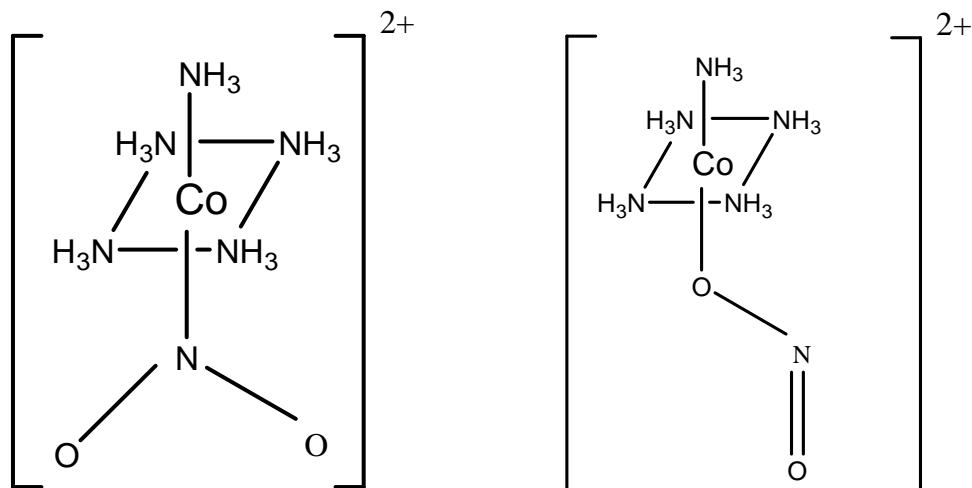

Pentaamminenitrocobalt(III)
Nitro isomer (N is the donor atom)

Pentaamminenitritocobalt(III)
Nitrito isomer (O is the donor atom)

atom)

Figure 7.2: Linkage isomerism

7.3.1.2 Ionization Isomerism

This is the phenomenon by which ligands present inside the coordination sphere and anion or neutral molecule present outside the coordination sphere can exchange their place. The central metal / ion and the other ligands except one that is exchangeable are similar in both the isomers. Thus, **ionization isomerism** is the exchange of ions between coordination sphere and ionization sphere. The physical and chemical properties of the two isomers are entirely different as they give different ions on dissolving in suitable solvent. Two octahedral ionization isomers will have five identical ligands while the sixth ligand will be different. In case of tetra coordinated isomers, three ligands will be identical and the fourth one will be the different one. The different ligand in one isomer may be outside of the coordination sphere in the other isomer. The oxidation state of the central ion would not be changed in the two isomers (**Figure 7.3**).

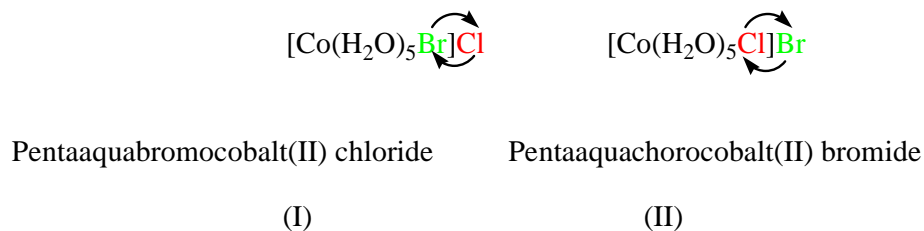

Figure 7.3: Ionization isomerism

green)

C. $[\text{Cr}(\text{H}_2\text{O})_4\text{Cl}_2]\text{Cl}\cdot 2\text{H}_2\text{O}$ Tetraaquadichlorochromium(III) chloride dihydrate (green)

Figure 7.5: Hydrate isomerism

These isomers have different chemical properties and on reaction with AgNO_3 , they produce 3, 2 and 1 mole of AgCl suggesting 3, 2 and 1 Cl^- (chloride ions) in solution, respectively.

7.3.1.5 Ligand isomerism

Certain ligands such as diamine derivatives of propane show two isomeric forms namely propylene diamine (pn) or 1, 2-diaminopropane and trimethylene diamine (tn) or 1, 3-diaminopropane. When such type of ligands forms complexes with metals, two isomers are obtained. The phenomenon is known as ligand isomerism and the isomers are called as ligand isomers (**Figure 7.6**).

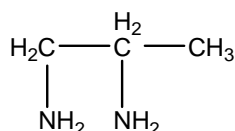

1,2-diaminopropane or
Propylenediamine (pn)

(A)

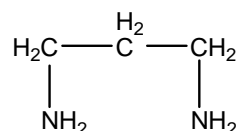

1,3-diaminopropane or
Trimethylenediamine (tn)

(B)

(A) and (B) are two isomeric ligands that show ligand isomerism.

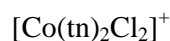
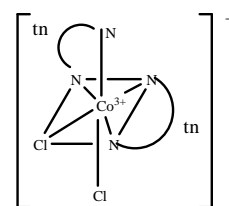
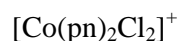
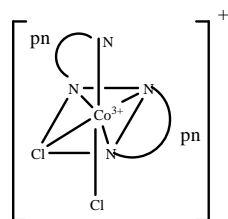
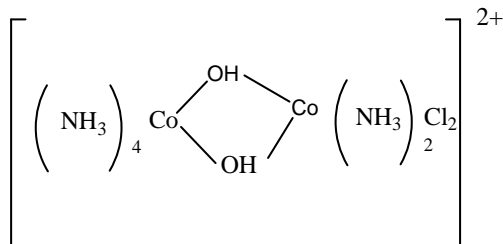

Figure 7.6: Ligand isomerism

7.3.1.6 Coordination position isomerism

This type of isomerism occurs in bridge compounds and arises due to differently placed non-bridging ligands round the central metal atom/ion (**Figure 7.7**).



Tetraamminecobalt(III)- μ -dihydroxodiamminedichlorocobalt(III)

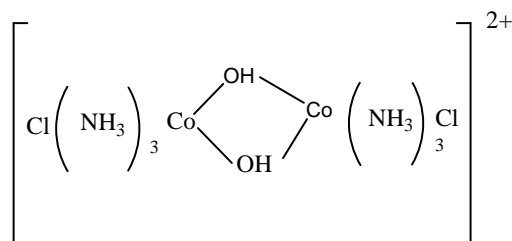

Triamminechlorocobalt (III)- μ -dihydroxotriamminechlorocobalt (III) ion

Figure 7.7: Coordination position isomerism

Ammonia and chloride ligands are differently placed in the above two different isomers.

7.3.2 Methods for identification of structural isomers

- (A) Conductivity method (Ionization isomers and hydrate isomers)
- (B) Electrolysis method (Coordination isomers)
- (C) Freezing point depression method (Hydrate isomers)
- (D) Infrared spectroscopy (Linkage isomers)

7.3.3 Stereoisomerism

Compounds which have the same atoms/groups, same position of atoms/groups and same sets of bonds, but differ in their spatial arrangement around the central atom/ ion are called as stereoisomers and the phenomenon is known as stereoisomerism. It is also called as **space isomerism**. It is of two types: **Geometrical isomerism** and **Optical isomerism**. Complexes of Co(III) were the first known coordination compounds to exist as stereoisomers. Purple and green salts of $[\text{CoCl}_2(\text{en})_2]^+$ were first observed by Jorgensen in 1889, which were later identified as

the *cis*- and *trans*- isomers by Werner. Werner and King (1911) reported optical isomers of the complex $cis-[CoX(NH_3)(en)_2]^{2+}$ (where $X=Cl^-$ or Br^-) for the first time.

7.3.3.1. Geometrical isomerism

The compounds with differences in geometrical arrangement of the ligands around the central atom/ ion are known as **geometrical isomers** and the phenomenon as **geometrical isomerism**. This is also called as ***cis-trans* isomerism**. The geometrical isomers have the same empirical formula but different physical and chemical properties due to different arrangement of the ligands in space. The geometrical isomers can be easily separated from each other. When similar atoms/groups (ligands) are adjacent to each other, the isomer is called ***cis*-isomer** (**Latin, *cis* = same**). In ***trans*-isomer**, the similar ligands are present diagonally opposite to each other (**Latin, *trans* = across**). It is common in di-substituted square planar and octahedral complexes with co-ordination number of 4 and 6, respectively. Tetrahedral (coordination number 4) complexes do not show geometrical isomerism because in this geometry, all the ligands are present in *cis*. position (adjacent) with respect to each other (all bond angles are same).

7.3.3.1.1 Four-coordinated compounds (Square planar complexes)

Among four coordinated complexes, square planar complexes show geometrical isomerism. The four coordinated complexes that show/ do not show geometrical isomerism are given in **Figure 7.8**.

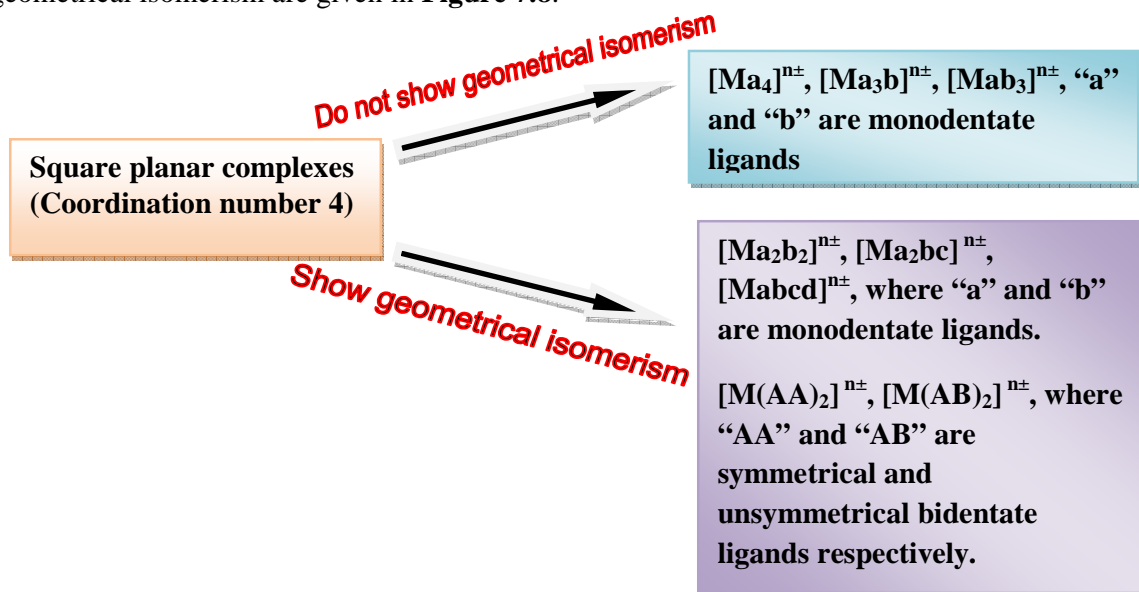

Figure 7.8: Geometrical isomerism in square planar complexes

(A) Compounds of the type $[Ma_2b_2]^{n\pm}$

The compound with molecular formula $[Pt(NH_3)_2(Cl)_2]$, exists as two isomers: *cis*- and *trans*-. *cis*- isomer is called as *cis*-platin and the *trans*- isomer as *trans*-platin.

Both the isomers have different chemical and biological properties. *cis*-[Pt(NH₃)₂(Cl)₂] is used as an anti-cancer agent in chemotherapy (cisplatin) while the *trans*- isomer is inactive against cancer. *cis*- and *trans*- is the position of 2 atoms/groups relative to each other (**Figure 7.9**). In the *cis*- isomer, two atoms/ groups are at 90° angle with respect to the central metal atom/ ion or adjacent to each other, whereas in the *trans*- isomer, the atoms/ groups are at 180° angle with respect to the central metal atom/ ion or "opposite to each other". In the complex of type [Ma₂b₂]^{n±}, both the *cis*- and *trans*- isomers are *cis* and *trans* with respect to the position of both the ligands "a" and "b". Only **two geometric isomers** are possible for this type of compound. The another example is [Pd(NH₃)₂(NO₂)₂]:

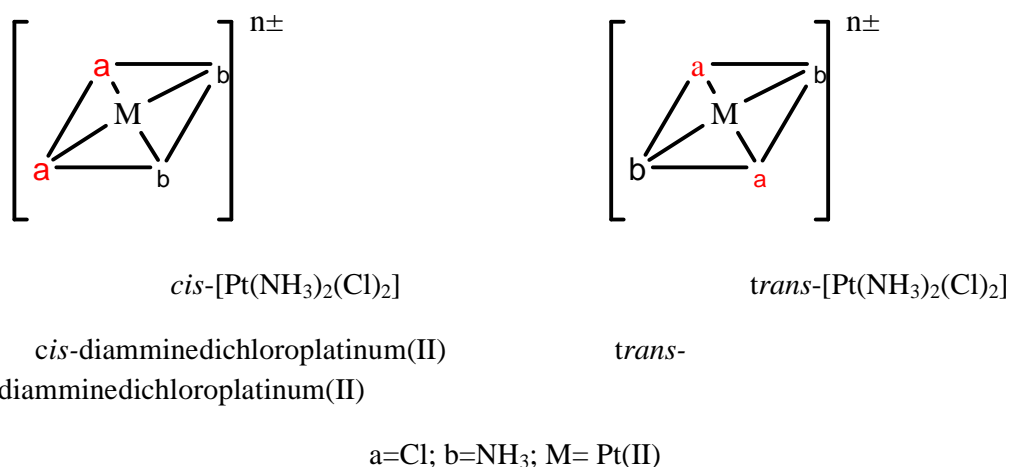

Figure 7.9: *cis*- and *trans*- isomers of [Ma₂b₂]^{n±} type compound

(B) Compounds of the type [Ma₂bc]^{n±}

In this type of compounds, *cis*- and *trans*- isomers are found with respect to the similar atoms/ groups such as "a". Atom/ group "a" is a neutral ligand such as NH₃, py and H₂O while "b" and "c" are anionic ligands like Cl⁻, Br⁻, NO₂⁻ etc (**Figure 7.10**).

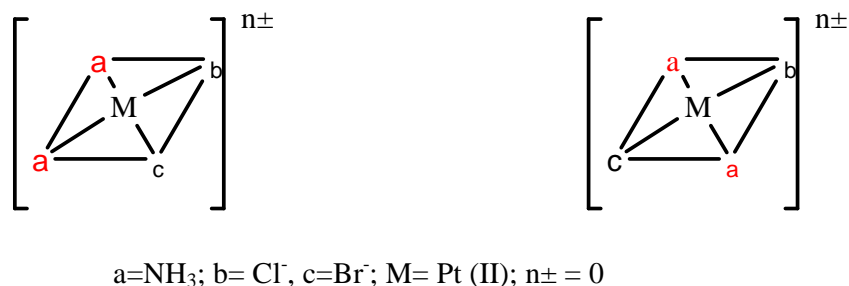

Figure 7.10: *cis*- and *trans*- isomers of [Ma₂bc]^{n±} type compounds

(C) Compounds of the type $[Mabcd]^{n\pm}$

Compounds of type $[Ma_2bc]^{n\pm}$ have three geometrical isomers. Il'ya Chernyaev (1928) had given the first report on the three geometric isomers for complexes of the type $[Mabcd]^{n\pm}$. He isolated and characterized all the three isomers. The three isomers can be obtained by fixing one atom/ group and the other atoms/ groups in trans to the fixed one. Platinum (Pt) shows a number of compounds of this type (**Figure 7.11**).

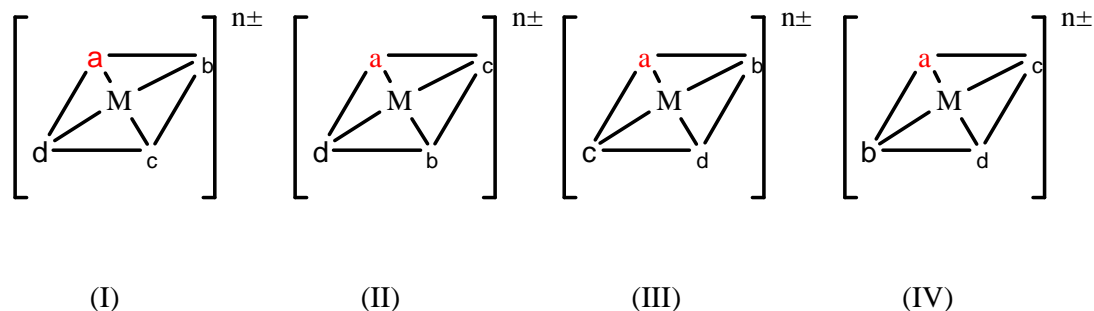

Figure 7.11: Geometrical isomers of compounds of the type $[Mabcd]^{n\pm}$

Structure III and IV are similar as b and c are next to “a” in each. Therefore, overall three isomers (I, II and III~IV) may exist in which c, b and d are trans to “a”.

(D) Compounds of the type $[M(\text{AA})_2]^{n\pm}$

Symmetrical bidentate ligands such as $\text{NH}_2.\text{CH}(\text{CH}_3).\text{CH}(\text{CH}_3).\text{NH}_2$ with platinum metal ion show *cis-trans* isomerism (**Figure 7.12**).

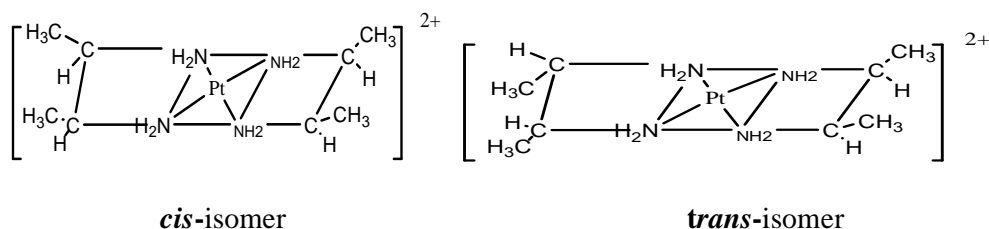

Figure 7.12: Geometrical isomerism in compounds of the type $[M(\text{AA})_2]^{n\pm}$

(E) Compounds of the type $[M(\text{AB})_2]^{n\pm}$

When the similar atoms (A) of both the unsymmetrical bidentate ligands are near to each other (at 90° angle with respect to central metal), the isomer is *cis*- and if the similar atoms present at opposite position to each other, the isomer will be *trans*- (**Figure 7.13**).

**trans-isomer**

AB = gly (NH₂CH₂COO⁻); M = Pt(II); n± = 0

Figure 7.13: Geometrical isomerism in compounds of the type [M(AB)₂]^{n±}

7.3.3.1.2 Six-coordinated compounds (octahedral complexes)

The types of six-coordinated compounds that can show / or cannot show geometrical isomerism, are presented in **Figure 7.14**.

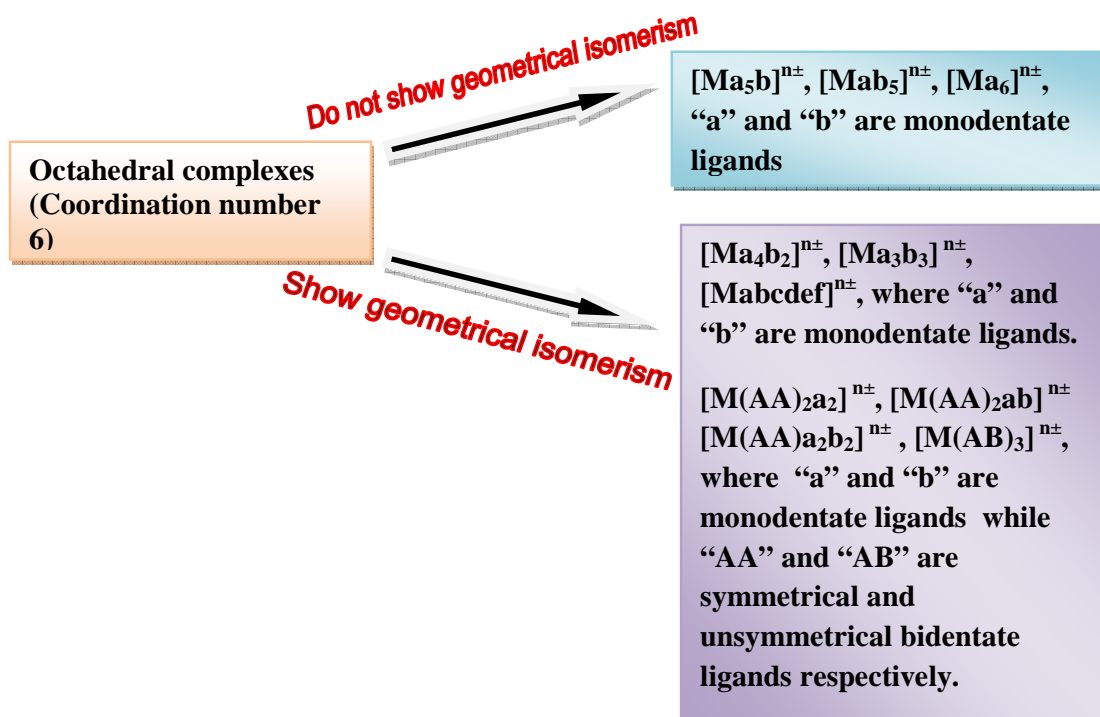

Figure 7.14: Geometrical isomerism in octahedral complexes

(A) Compounds of the type [Ma₄b₂]^{n±}

Two isomers are possible for such compounds: *cis*- and *trans*-. The two similar atoms or groups are at 90° angle with respect to the central metal atom / ion (**Figure 7.15**).

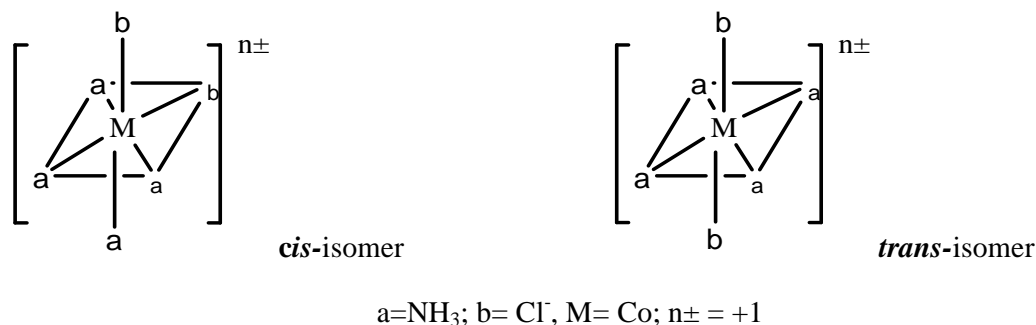

Figure 7.15: Geometrical isomerism in compounds of the type $[\text{Ma}_4\text{b}_2]^{n_{\pm}}$

(B) Compounds of the type $[\text{Ma}_3\text{b}_3]^{n_{\pm}}$

In case of $[\text{Ma}_3\text{b}_3]^{n_{\pm}}$ type compounds, the two possible geometrical isomers are called as *facial* and *meridional* isomers. When the three same atoms or groups are placed on one face of the octahedral, *facial* isomer is generated. The three similar atoms or groups placed in a plane passing through metal atom/ion around the centre gives rise to another isomer called as *meridional* isomer. The isomers are named on the basis of relative positions of the ligands around the octahedron (**Figure 7.16**).

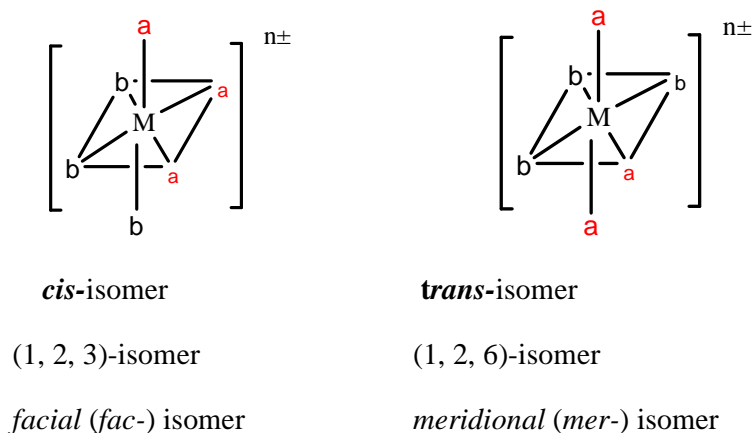

Figure 7.16: Geometrical isomerism in compounds of the type $[\text{Ma}_3\text{b}_3]^{n_{\pm}}$

(C) Compounds of the type $[\text{Mabcdef}]^{n_{\pm}}$

This type of compounds may give rise to 15 isomers obtained after exchanging all the ligands (**Figure 7.17**). $[\text{Pt}(\text{py})(\text{NH}_3)(\text{NO}_2)(\text{Cl})(\text{Br})(\text{I})]$ is the only compound that shows this type of geometrical isomerism.

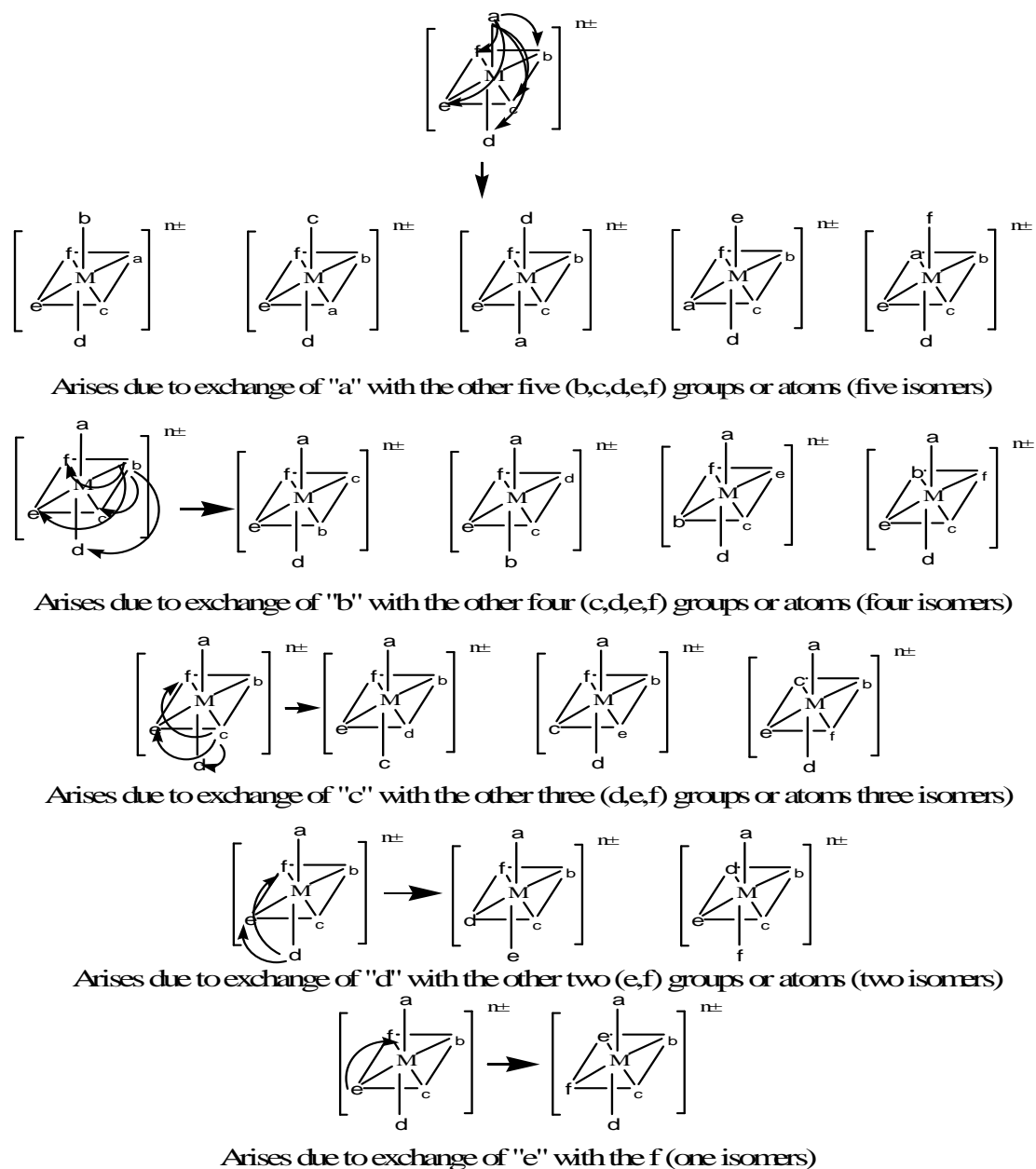

Figure 7.16: Fifteen geometrical isomers of compound $[Mabcdef]^{n\pm}$

(D) Compounds of the type $[M(AA)_2a_2]^{n\pm}$

Two geometrical isomers are possible for $[M(AA)_2a_2]^{n\pm}$ type of compounds. In *cis*-form monodentate ligands, "a"s are *cis* to each other while in *trans*-isomer, "a"s are *trans* to each other (Figure 7.17).

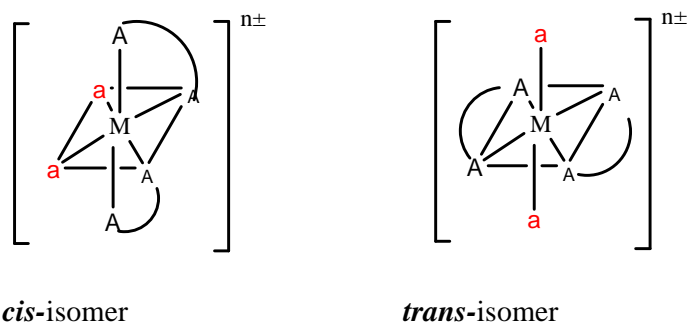

Figure 7.17: Geometrical isomerism in compounds of the type $[\text{M}(\text{AA})_2\text{a}_2]^{n_{\pm}}$

(E) Compounds of the type $[\text{M}(\text{AA})_2\text{a}_2\text{b}_2]^{n_{\pm}}$

$[\text{Co}(\text{en})(\text{NH}_3)_2\text{Cl}_2]^+$ Compound shows geometrical isomerism of this type (**Figure 7.18**).

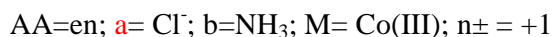
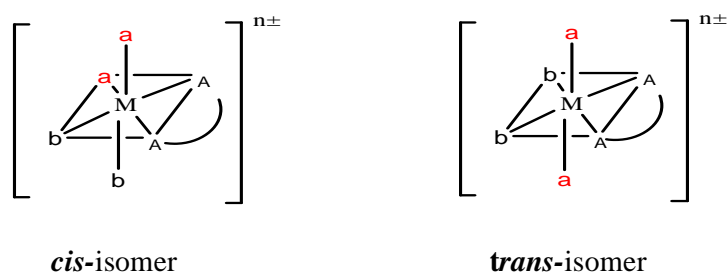

Figure 7.18: Geometrical isomerism in compounds of the type $[\text{M}(\text{AA})_2\text{a}_2\text{b}_2]^{n_{\pm}}$

(F) Compounds of the type $[\text{M}(\text{AB})_3]^{n_{\pm}}$

One example of this type of compound is trisglycinatochromium (III), $[\text{Cr}(\text{gly})_3]$, (**Figure 7.19**).

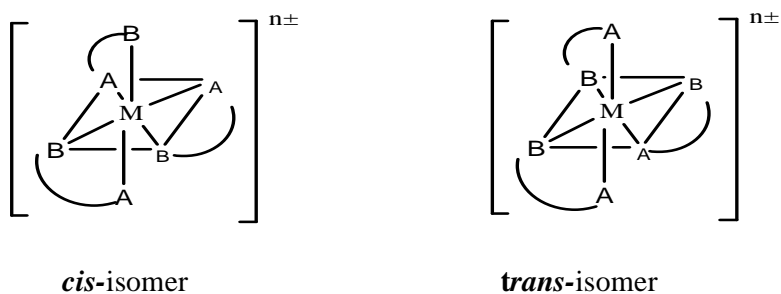
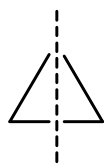

Figure 7.19: Geometrical isomerism in compounds of the type $[\text{M}(\text{AB})_3]^{n_{\pm}}$

7.3.3.2 Optical isomerism

Certain complex compounds in solution form can rotate the plane of polarized light either in right or left direction. This property of a compound to rotate plane of polarized light is called **optical activity** and the compounds which possess this property are called as **optically active compounds**. The compound that can rotate plane of polarized light towards right side are called as dextrorotatory (*d* or +) while the compound that can rotate the plane of polarized light towards left side is called as laevorotatory (*l* or -). These optically active compounds are also called as **optical isomers** or **enantiomorphs** or **enantiomers** (Latin, enantio=opposite; morphs=forms). Optical isomers have same physical and chemical properties but have different property with respect to the rotation of the plane of polarized light and the isomerism possessed by these isomers is called as **optical isomerism** or **enantiomerism** or **chirality**. The compounds that cannot rotate plane of polarized light are called as **optically inactive compounds** or **racemic mixture** (*dl* or \pm form; 50% *d* form and 50% *l* form). The compounds that show optical isomerism should be:

- Asymmetric (no plane of symmetry). The molecules cannot be divided into two equal parts when cut through an imaginary plane (mirror plane) (**Figure 7.20**). You can also call them chiral compounds.



Mirror plane

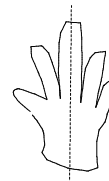

Mirror plane

Symmetric having plane of symmetry Asymmetric having no plane of symmetry

Figure 7.20: Examples showing symmetry and asymmetry

The mirror images are non-superimposable on each other (Figure 7.21).

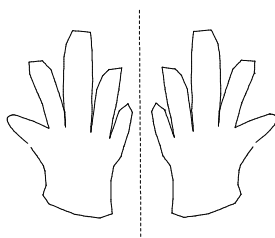

Mirror plane

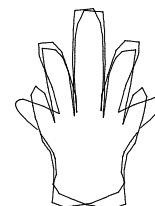

Non-superimposable

Figure 7.21: Examples showing nonsuperimposable mirror images

7.3.3.2.1 Four-coordinate complexes

You should remember that tetrahedral and square planar complexes such as $[Ma_4]^{n\pm}$, $[Ma_3b]^{n\pm}$ and $[Mab_3]^{n\pm}$ type do not possess optical isomerism because all possible arrangement of bonds around the central metal atom or ion are identical (**Figure 7.22**).

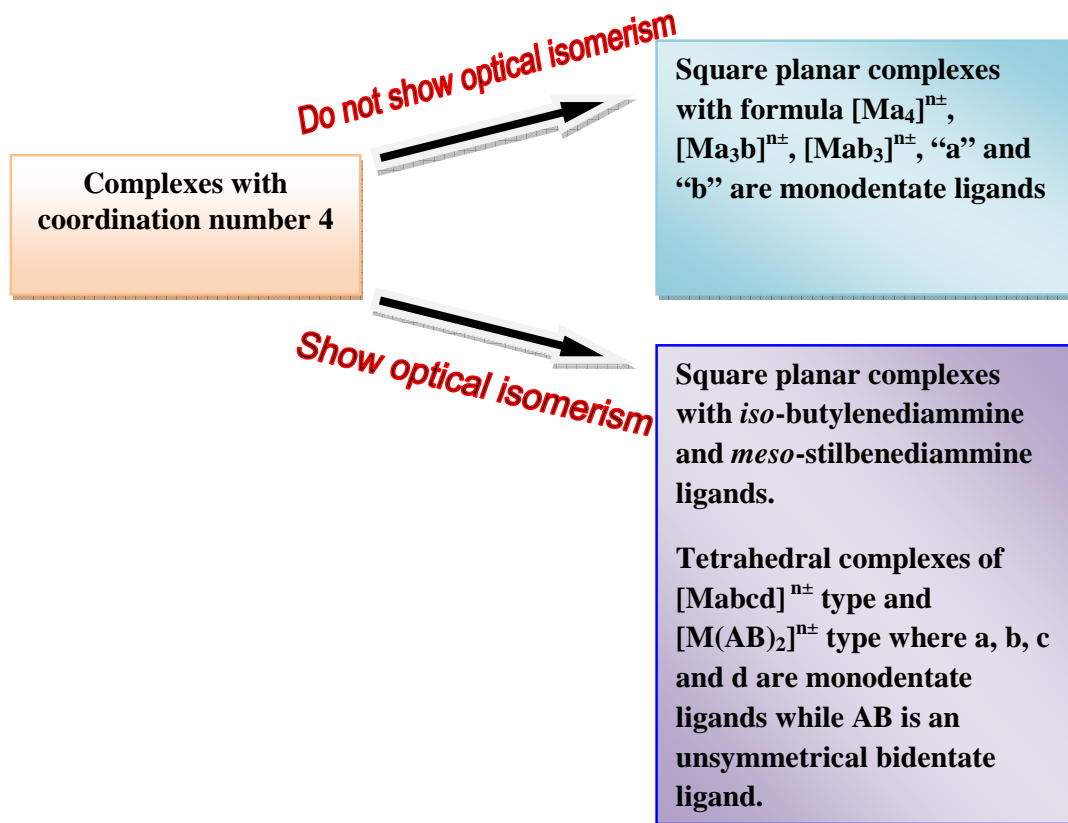

Figure 7.22: Optical isomerism in four coordinate complexes

(A) Square planar complexes

Optical isomerism is rare in case of square planar complexes even if all the four ligands are different. In a complex of Pt(II) with *iso*-butylenediammine and *meso*-stilbenediammine ligands, optical isomerism was observed. This is so because, both the phenyl groups of *meso*-stilbenediammine ligand are present above the plane of the ring and H atoms below the plane of the ring. Therefore, the compound has no plane of symmetry and possesses optical isomerism. Mills and Quibell (1935) resolved the two optical isomers of this compound (**Figure 7.23**).

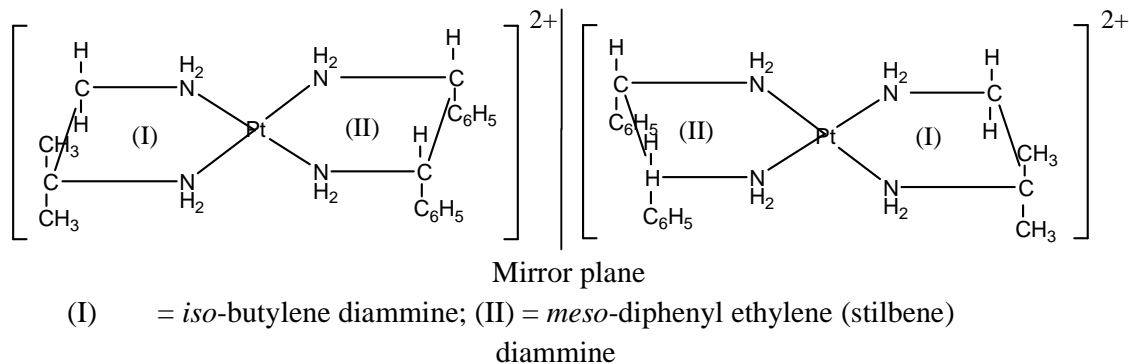

Figure 7.23: Square planar complex showing optical isomerism

(B) Tetrahedral complexes

- Tetrahedral complexes such as $[Mabcd]^{n\pm}$ show optical isomerism (**Figure 7.24**).

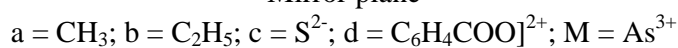
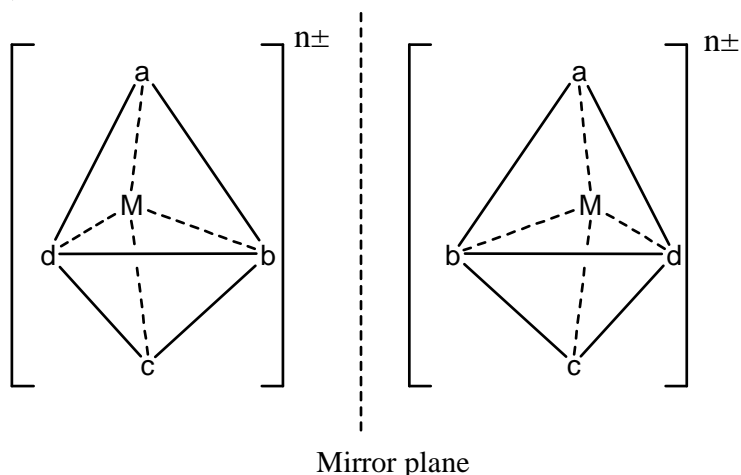

Figure 7.24: Optical isomerism in $[Mabcd]^{n\pm}$ type complexes

- Complexes of the $[M(\text{AB})_2]^{n\pm}$ type:** Tetrahedral complexes of some metals like Be(II), B(II) and Zn(II) with unsymmetrical ligands such as benzoylacetone possess optical isomerism (**Figure 7.25**).

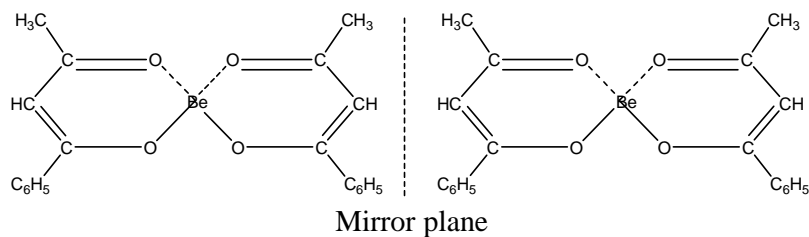

Figure 7.25: Optical isomerism in tetrahedral complex with unsymmetrical bidentate ligand

7.3.3.2.2 Six-coordinate complexes

Octahedral complexes (six-coordinate complexes) that can show optical isomerism are given in **Figure 7.26**. The details of optical isomerism of six-coordinate compounds are further given in this section.

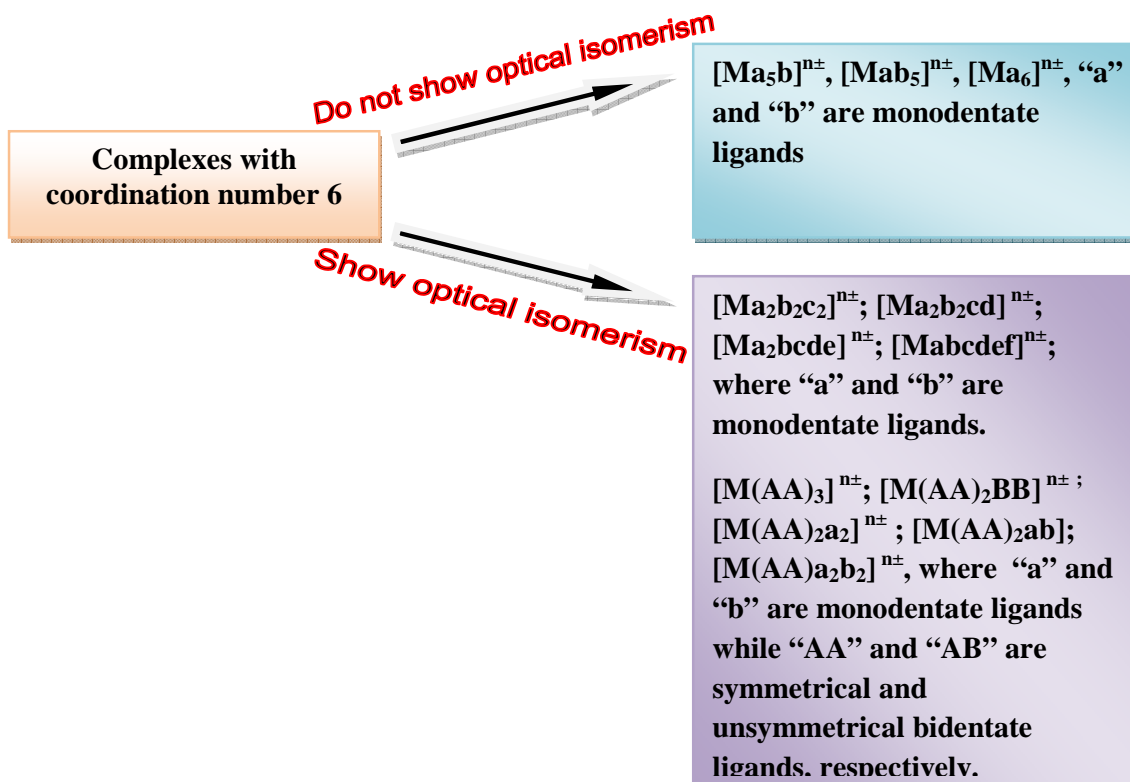

Figure 7.26: Optical isomerism in six coordinate complexes

(A) Compounds of the type $[Ma_2b_2c_2]^{n\pm}$ (Figure 7.27)

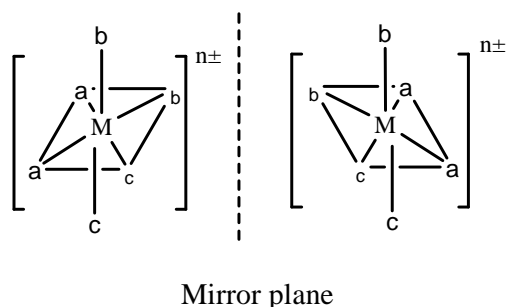
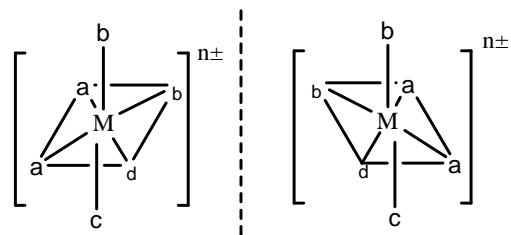
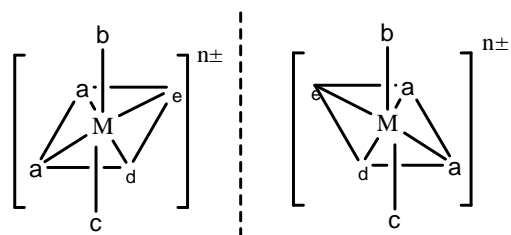

Figure 7.27: Optical isomerism in $[Ma_2b_2c_2]^{n\pm}$ type compounds

(B) Compounds of the type $[Ma_2b_2cd]^{n\pm}$ (Figure 7.28)



Mirror plane

Figure 7.28: Optical isomerism in $[Ma_2b_2cd]^{n\pm}$ type compounds**(C) Compounds of the type $[Ma_2bcde]^{n\pm}$ (Figure 7.29)****Figure 7.29:** Optical isomerism in $[Ma_2bcde]^{n\pm}$ type compound**(D) Compounds of the type $[Mabcdef]^{n\pm}$**

Total thirty optical isomers are possible for this compound. Each of fifteen geometrical isomers has two enantiomers (**Figure 7.30**). The example of this type of complex is $[Pt(py)(NH_3)(NO_3)(Cl)(Br)(I)]$.

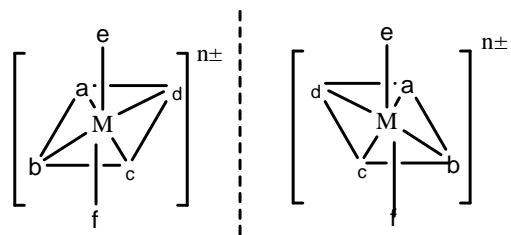

Mirror plane

Figure 7.30: Optical isomerism in $[Mabcdef]^{n\pm}$ type compounds**(E) Compounds of the type $[M(AA)_3]^{n\pm}$**

A number of coordination compounds of this type show optical isomerism (**Figure 7.31**). Metals like Co(III), Pt(IV), Fe(III), Ir(IV), Rh(IV), Co(II and III), Al(III) and Zn(II) with symmetrical bidentate ligands such as ethylene diamine (en), oxalato and propylene diamine (pn) show optical isomerism.

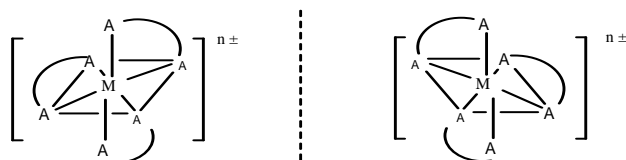

Mirror plane

Figure 7.31: Optical isomerism in $[M(AA)_3]^{n\pm}$ type compounds

(F) Compounds of the type $[M(AA)_2(BB)]^{n\pm}$

In this type of compounds, AA and BB are two different kinds of symmetrical bidentate ligands. The ligand AA is neutral symmetrical bidentate ligand while BB is anionic symmetrical bidentate ligand (**Figure 7.32**).

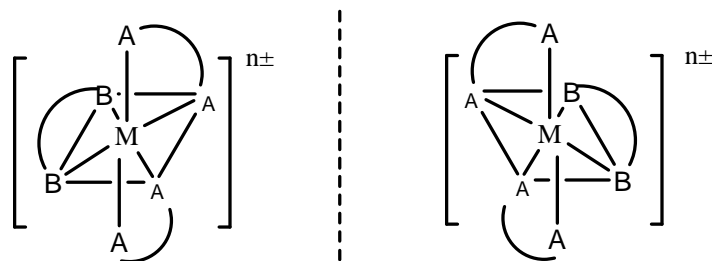

Mirror plane

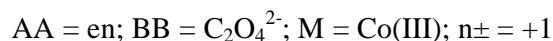
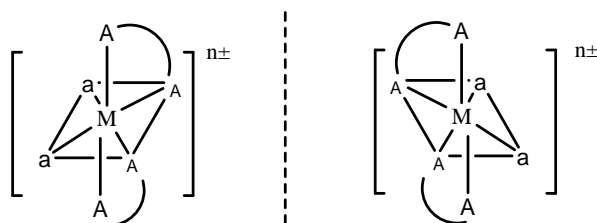

Figure 7.32: Optical isomerism in $[M(AA)_2(BB)]^{n\pm}$ type compounds

(G) Compounds of the type $[M(AA)_2(a)_2]^{n\pm}$

These types of compounds have two geometrical isomers: *cis*- and *trans*-. The *trans*-isomer (**Figure 7.34**) is mesomeric (optically inactive having plane of symmetry) in nature while the *cis*-form exists as two optical isomers. These two forms are mirror image of each other (**Figure 7.33**).



Mirror plane



Figure 7.33: Optical isomerism in $[M(AA)_2(a)_2]^{n\pm}$ type compounds (*cis*-isomer with respect to "a")

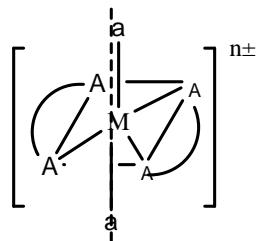

Mirror plane

Figure 7.34: *trans*-isomer of $[M(AA)_2(a)_2]^{n\pm}$ complex which is mesomeric in nature

(H) Compounds of the type $[M(AA)_2ab]^{n\pm}$

This type of compound exists in three isomeric forms. Two *cis*- forms (**Figure 7.35**) are optically active while the *trans*- form is optically inactive (*meso*- form) (**Figure 7.36**).

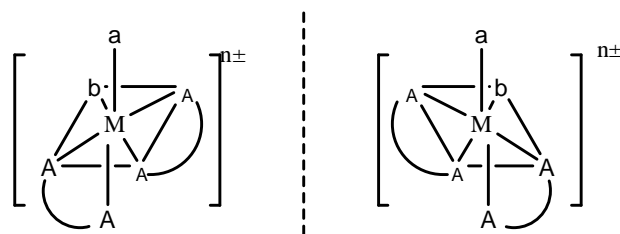

Mirror plane

AA = en; a = NH₃; b = Cl⁻; M = Co(III); n± = +2

Figure 7.35: Optical isomerism in *cis*- $[M(AA)_2ab]^{n\pm}$ type compounds

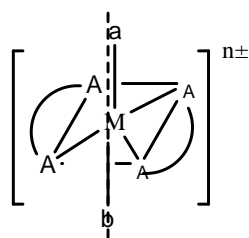

Mirror plane

Figure 7.36: *meso* form of $[M(AA)_2ab]^{n\pm}$ type compound

(I) Compounds of the type $[M(AA)_2a_2b_2]^{n\pm}$

This type of compounds also exist in three isomeric forms: two optically active *cis*-forms (**Figure 7.37**) and one optically inactive *trans*-form (*meso* form with plane of symmetry) (**Figure 7.38**).

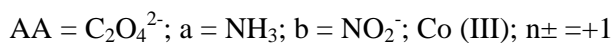
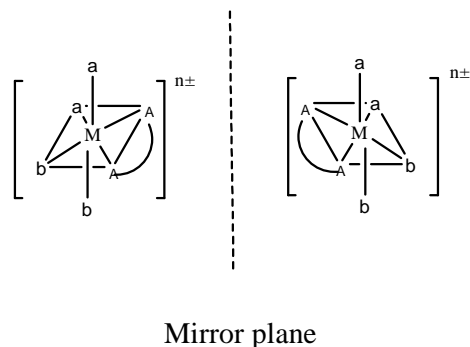

Figure 7.37: Optically active form of $cis-[M(AA)_2b_2]^{n_{\pm}}$ type compound

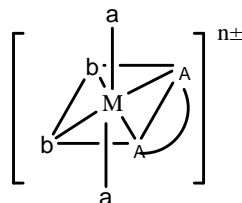

Figure 7.38: *meso* form of $trans-[M(AA)_2b_2]^{n_{\pm}}$ compound

7.3.3.3 Importance of stereoisomerism

The chemistry of our body is controlled by stereochemically active molecules and therefore, different stereoisomers of a molecule react in different ways in our body system. Different enantiomers of chiral drug exhibit different reactivity. Only one chiral form of chiral molecules is present in living organisms. The amino acids present in proteins are found as their L isomers whereas glucose occurs as its D isomer in human body. Most of the drugs are generally composed of a single stereoisomer of a compound. One stereoisomer may positively affect our body or the other isomer may have toxic effects. Therefore, it is a challenge today to synthesize stereochemically pure drugs. S-enantiomer of citalopram; an antidepressant drug, is thirty times potent as compared to R-enantiomer. Thalidomide, a very common drug used for treatment of morning sickness in pregnant women in 1950s-1960s, was found to be a racemic mixture (mixture of the two isomers: R- and S- which are mirror image to each other) caused serious birth defects. R- isomer can treat morning sickness while the other isomer S- causes birth defects. Even if the correct isomer is

given for treatment, it undergoes racemisation which results in the production of both safe and harmful forms of thalidomide.

Cisplatin or *cis-platinum*, or *cis*-diamminedichloroplatinum (II) (CDDP), an inorganic stereoisomer, is a chemotherapy drug used for treatment of ovarian and testicular cancers while *trans*-platin, the *trans* stereoisomer of *cis*-platin is toxic in nature.

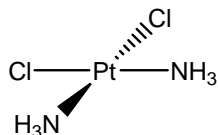

cis-diamminedichloroplatinum (II)
(*cis*-platin)

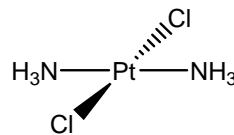

trans-diamminedichloroplatinum (II)
(*trans*-platin)

The activity of a particular isomer is due to the stereospecific (the 'fit' in such must be correct as a lock and key fit) nature of biological interactions between molecules.

7.3.3.4 Methods for identification of stereoisomers

- (A) Dipole moment method (*cis* and *trans* isomers)
- (B) Nuclear Magnetic Resonance (NMR) Spectroscopy (*cis* and *trans* isomers)
- (C) Greinberg's method (*cis* and *trans* isomers)
- (D) Mass spectrometry (both optical and *cis* and *trans* isomers)
- (E) Infrared Spectroscopy (*cis* and *trans* isomers)

7.4 VALENCE BOND THEORY (VBT) OF TRANSITION METAL COMPLEXES

Valence bond theory was given by Pauling and Slater in 1935. According to this theory:

- ✓ In coordination compounds, the ligands form covalent-coordinate bonds to the metal atom/ ion. The central metal atom/ ion provide vacant orbitals (s, p and /or d atomic orbitals) equal to its coordination number. These vacant orbitals

hybridize and form the same number of new hybridized orbitals (atomic orbitals overlap) of equal energy.

- ✓ Ligands can donate at least one lone pair (in σ orbital) of electrons to the empty hybrid orbitals of the central metal atom/ ion.
- ✓ Each ligand with filled σ orbital then overlap with the empty hybrid orbital of central metal atom/ ion.

This theory helps in predicting the shape, stability and calculating magnetic moment (magnetic property: $\mu = \sqrt{n(n+2)}$) of the metal complexes.

Spectrochemical series of ligands

A spectrochemical series is the ordered arrangement on ligand strength from lower strength (small Δ_o) to higher strength (large Δ_o). The ligands on the left end are weaker ligands (σ -donor) which can donate a pair the electrons in (n-1)d orbitals of metal/ion. The right end ligands are stronger (π -acceptor) ligands and can accept pair of electrons from filled (n-1)d orbitals in the metal atom/ion. The spectrochemical series of ligands is given as:

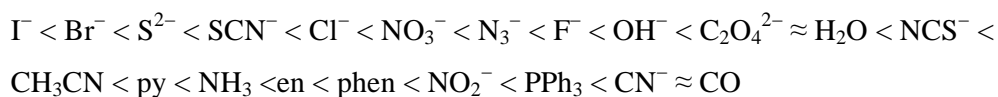

The position of ligand in the spectrochemical series and nature of central metal atom/ion affects the hybridization, structure, stability and magnetic moment of complexes.

(A) Four coordinate compounds (Tetrahedral complexes)

In case of tetrahedral complexes, the central metal atom / ion provides four vacant orbitals (one s and three p). These four orbitals hybridize to form four sp^3 hybridized orbitals. Each hybridized orbital then overlaps with the filled p orbitals of the each ligand. The geometry of such complexes will be tetrahedral. Hybridization and thus, geometry of a complex depends upon the type of ligand (σ -donor or π -acceptor) attached to the central metal atom / ion. Electrons of metal atom / ion are shown as $\uparrow\downarrow$, whereas those of the electron pair on ligand are depicted as xx. For example,

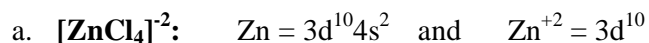

In this complex, the ligand is weak and the d orbitals of Zn^{2+} ion are filled. Hence, it is a diamagnetic substance (no unpaired electron) and the geometry is tetrahedral. The central metal ion; Zn^{2+} is sp^3 hybridized.

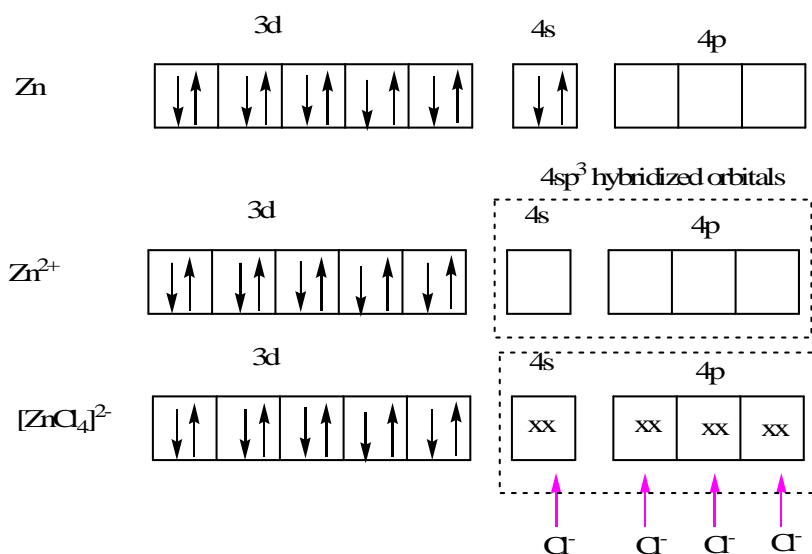
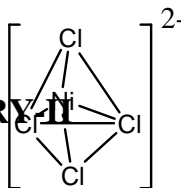

b. [NiCl₄]²⁻: Electronic configuration of Ni is 3d⁸4s² and hence, electronic configuration of Ni²⁺ is 3d⁸.

In this complex, the ligand is weak and no pairing of electrons will occur. There are two unpaired electrons in d orbitals of Ni²⁺. Hence, it is a paramagnetic in nature. The central metal ion; Ni²⁺ is sp³ hybridized and the geometry is tetrahedral.

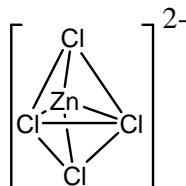
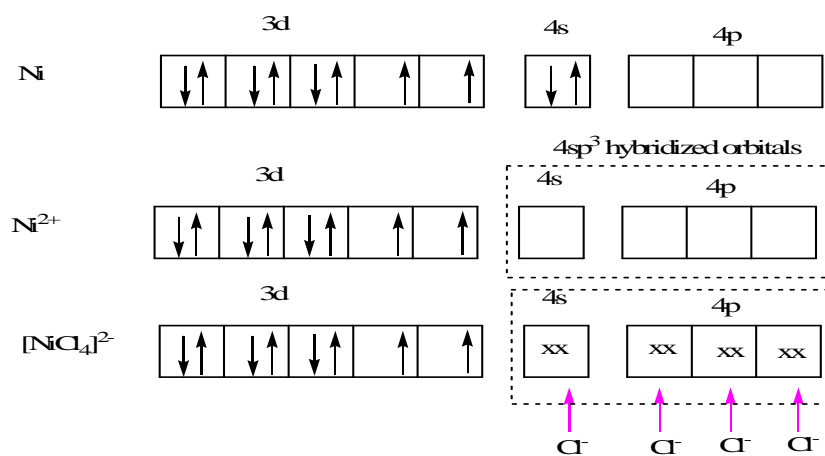

- c. $[\text{Ni}(\text{CO})_4]$: $\text{Ni} = 3d^8 4s^2$. In this complex, Ni is in 0 oxidation state. The ligand is strong and hence, pairing of electrons will occur. There are no unpaired electrons in d orbitals of Ni^{2+} . Hence, it is a diamagnetic in nature. The central metal atom Ni is sp^3 hybridized and the geometry is tetrahedral.

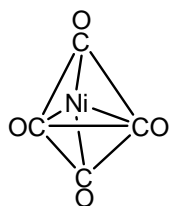
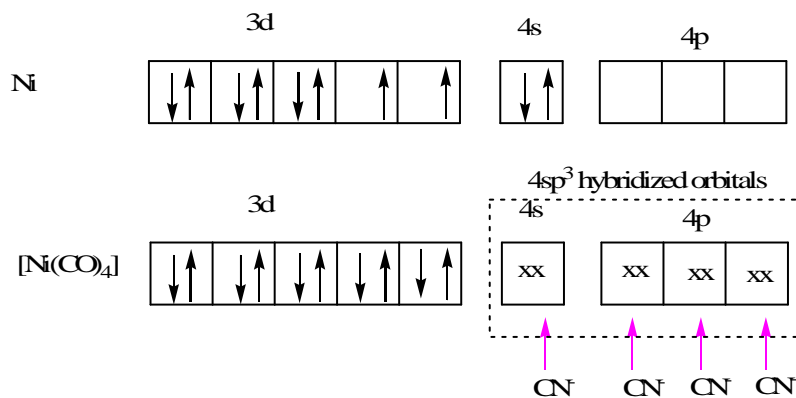

- d. $[\text{MnCl}_4]^{2-}$: Electronic configuration of Mn (atomic number 25) is $3d^5 4s^2$, and hence, the electronic configuration of Mn^{2+} is $3d^5$. In this complex, again the ligand is weak and no pairing of electrons will occur. There are five unpaired electrons in d orbitals of Mn^{2+} . Hence, it is a paramagnetic in nature. The central metal ion; Mn^{2+} is sp^3 hybridized and the geometry is tetrahedral.

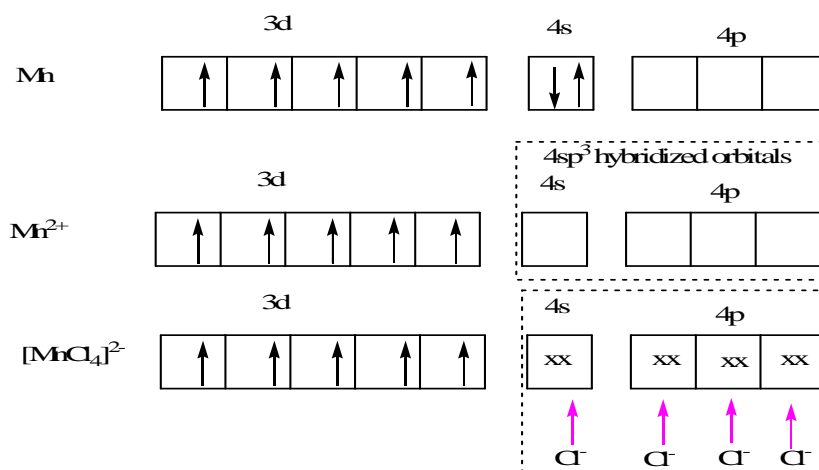

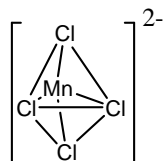

(B) Four coordinate compounds (Square planar complexes)

- a. $[\text{Ni}(\text{CN})_4]^{2-}$: As you know, the electronic configuration of Ni = $3d^8 4s^2$, nickel in this complex is in +2 oxidation state, hence $\text{Ni}^{+2} = 3d^8$. You also know that CN^- is a strong field ligand, hence pairing of electrons will occur. There will be no unpaired electrons in d orbitals of Ni^{2+} . Hence, it is diamagnetic in nature. The central metal ion; Ni^{2+} provides one inner d orbital and thus, is dsp^2 hybridized and square planar.

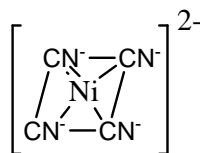
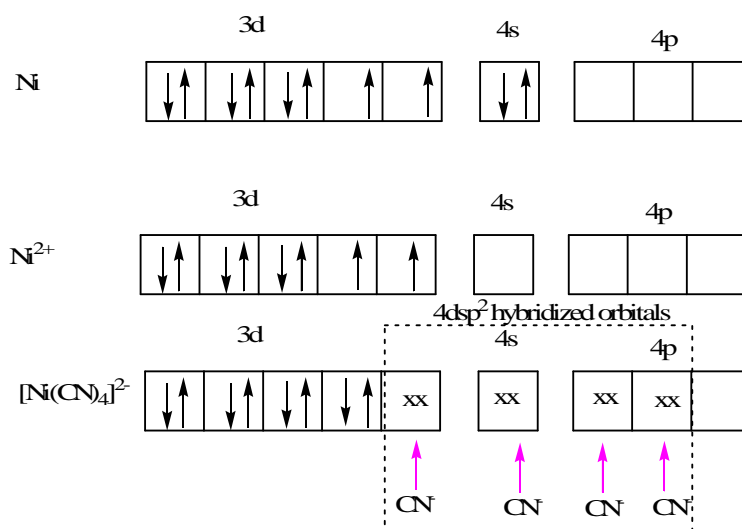

In ' dsp^2 ' hybridization, 'd' precedes ' sp^2 ' indicating that the lower (inner) shell d-orbital is used in hybridization that comes before the 's' and 'p' orbitals. This is called **inner shell hybridization** (form inner shell complexes). When outer shell d-orbitals are used in hybridization, it is called as **outer shell** (form outer shell complexes) hybridization.

(C) Six coordinate compounds (Octahedral complexes)

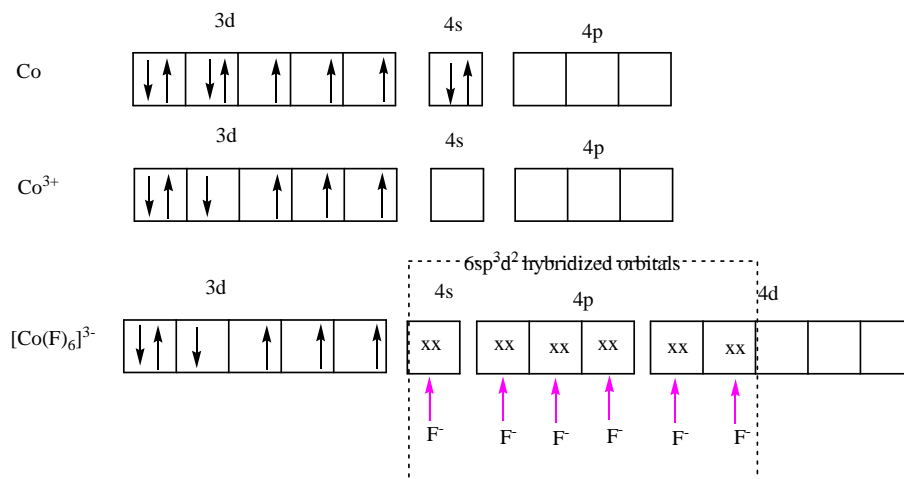

- c. **[Co(NH₃)₆]³⁺:** In this complex also, cobalt is in +3 oxidation state and has 3d⁶ configuration. As NH₃ is a strong field ligand, pairing of electrons will occur. There are no unpaired electrons in d orbitals of Co³⁺. Hence, it is a diamagnetic in nature. The central metal ion Co³⁺ provides inner d orbitals for complex formation, is thus d²sp³ hybridized (inner shell orbital complex) and the complex is octahedral in shape:

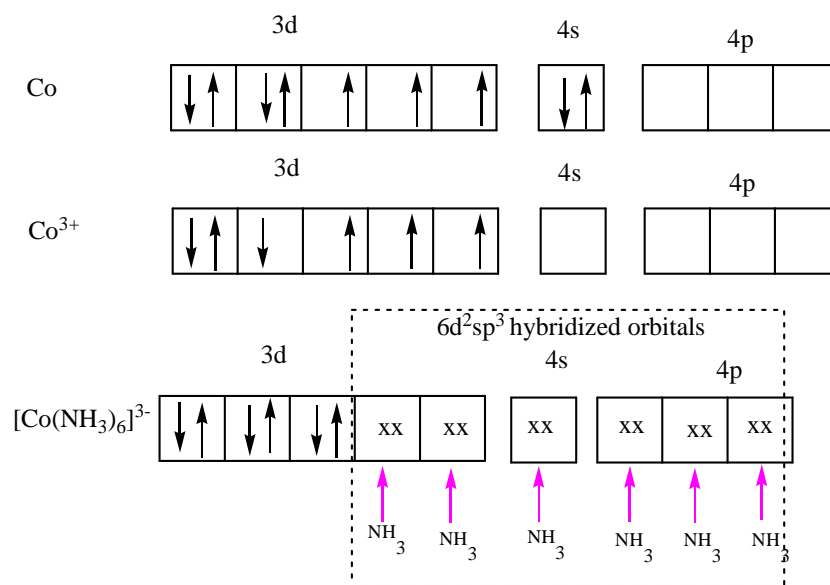

- d. **[Fe(CN)₆]³⁻:** Iron (atomic no. 26) has 3d⁶ 4s² as valence shell configuration, with iron in +3 oxidation state; Fe³⁺ having 3d⁵ configuration. In this complex, the ligand CN⁻ is a strong field ligand, hence, pairing of electrons will take place. There will be one unpaired electron in d orbital of Fe³⁺. Hence, it will be paramagnetic in nature. The central metal ion, Fe³⁺, provides

inner d orbitals and thus, is d^2sp^3 hybridized (inner shell orbital complex) and octahedral in shape.

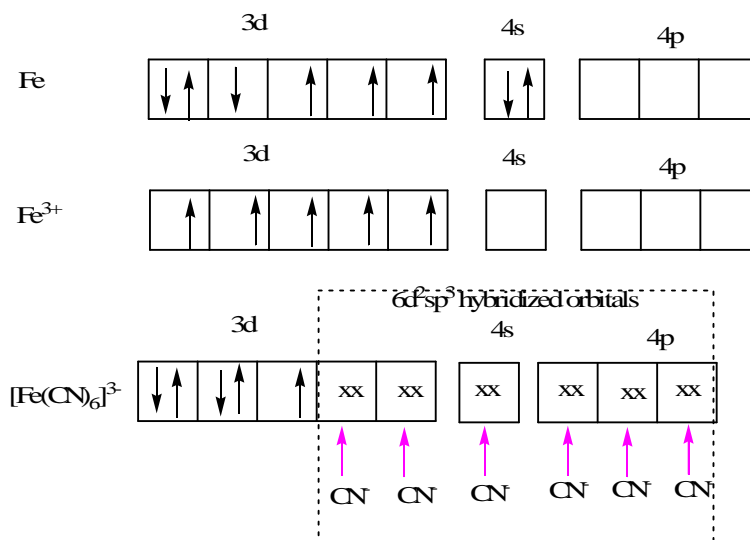

- e. **[Fe(H₂O)₆]³⁺** : Iron (atomic no. 26) has $3d^6 4s^2$ as valence shell configuration, with iron in +3 oxidation state; Fe⁺³ having $3d^5$ configuration. In this complex, the ligand water is a weak field ligand hence; pairing of electrons does not take place. There are five unpaired electrons in d orbitals of Fe³⁺. Hence, it is paramagnetic in nature. The central metal ion Fe³⁺ provides outer d orbitals and is thus, sp^3d^2 hybridized (outer shell orbital complex) and octahedral in shape.

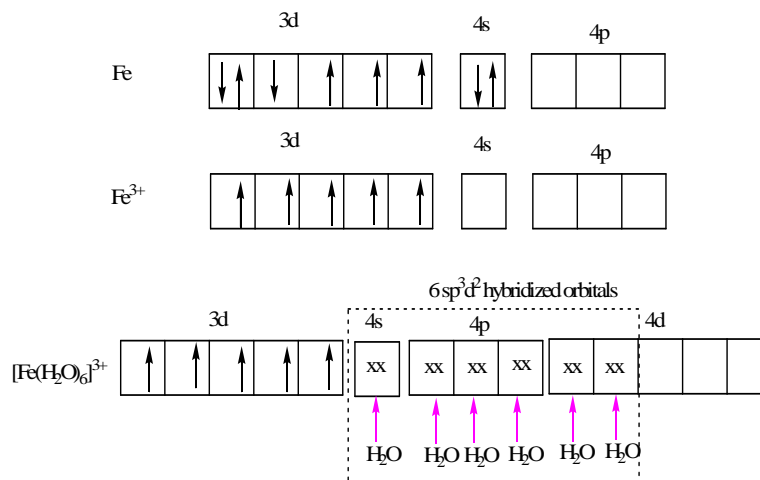

- f. **[Mn(CN)₆]⁴⁻** : Manganese (atomic no. 25) has $3d^5 4s^2$ as valence shell configuration, with manganese in +2 oxidation state; Mn²⁺ having $3d^5$ configuration. In this complex, the CN⁻ ligand is a strong field ligand. Hence,

pairing of electrons takes place. However, there is one unpaired electron in d orbitals of Mn^{2+} , it is a paramagnetic in nature. The central metal ion Mn^{2+} provides inner d orbitals and is d^2sp^3 hybridized (inner shell orbital complex). Therefore, the complex, $[\text{Mn}(\text{CN})_6]^{4-}$ has an octahedral structure:

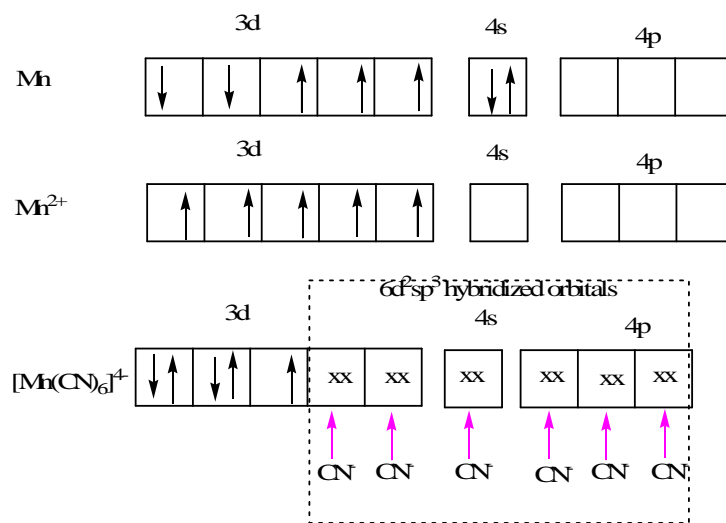

Limitations of VBT:

- ✓ Cannot explain colour of complexes.
- ✓ Cannot explain why magnetic moments of some metal complexes are temperature dependent.
- ✓ Cannot explain the structure of Cu^{2+} complexes.

7.5 SUMMARY

In this unit, you have studied that:

- Isomers are the molecules having the same number of atoms/ groups and thus, same chemical formula but have different structural formula (different arrangement of atoms or groups).
- Isomers can be divided into two main categories: structural isomers and space or stereoisomers.
- In structural isomers, the atoms/ groups are arranged in different ways (pattern of bonding is different).
- In stereoisomers, the arrangement of atoms/ groups in space is different and their pattern of bond is the same. These are of two types: geometrical isomerism and optical isomerism.

- Stereoisomers are important as they control our body system and also useful in drug designing.

7.6 DEFINITIONS

Cis-isomer: When identical ligands are present at positions next to each other, the compound is called *cis* –**isomer**.

Dextrorotatory (*d*-form): The enantiomer that can rotate the plane of polarized light to the right side.

Enantiomers: Enantiomers are the optical isomers having chiral centres.

Isomerism: Isomerism is the phenomenon of position and /or arrangement of atoms or groups around the central metal ion/ atom.

Isomers: Isomers are the compounds having same chemical formula but different physical and chemical properties.

Laevorotatory (*l*-form): The enantiomer that can rotate the plane of polarized light to the left side.

Optical activity: Optical activity is the property of compounds by virtue of which they can rotate plane of polarized light.

Plane of symmetry: An imaginary plane when passes through a molecule, divides it into two equal forms which are mirror image of each other.

Racemic mixture (*dl* -form): The optically inactive compound that cannot rotate plane of polarized light.

Stereoisomerism: This isomerism occurs in those compounds in which atoms or groups are differently placed in space.

Structural isomerism - This isomerism occurs in compounds having different bond arrangements around the central metal ion/ atom.

trans-isomer- When identical ligands occupy positions opposite to each other, the isomer is called *trans*-**isomer**.

7.7 QUESTIONS FOR PRACTICE

7.7.1 State True (T) or False (F)

- The structural isomers have different physical and chemical properties.
- CN⁻/NC⁻ ligands show linkage isomerism.
- SCN⁻ is monodentate and ambidentate ligand.
- Ionization isomers give same ions in solution.
- Ionization isomer of [Pt (NH₃)₃(NO₂)]Br is [Pt (NH₃)₃(Br)]NO₂.
- Coordination isomerism occurs in all coordination compounds.
- Exchange of water molecule between inside and outside the coordination sphere is called as hydrate isomerism.
- Bridged complexes are the best examples of coordination position isomerism.

- i. Stereoisomerism is also known as space isomerism.
- j. *cis-trans* isomerism is also called as optical isomerism.
- k. Enantiomers are the superimposable mirror image of each other.
- l. Tetrahedral complexes show geometrical isomerism.
- m. Cisplatin is used as a chemotherapeutic drug.
- n. $[Mabcd]^{n\pm}$ occurs as three geometrical isomers.
- o. $[Ma_3b_3]^{n\pm}$ exhibit geometrical isomerism.
- p. $[Mabcdef]^{n\pm}$ has thirty optical isomers.
- q. *trans*- $[M(AA)_2b_2]$ is optically inactive.
- r. Square planar complexes rarely show optical isomerism.
- s. CN^- is a strong field ligand.
- t. $[Fe(H_2O)_6]^{3+}$ is paramagnetic in nature.
- u. $[Ni(CN)_4]^{2-}$ is square planar.
- v. $[Cr(NH_3)_6]^{3+}$ form inner shell orbital complexes.

7.7.2 Fill in the blanks

- a. The coordination compounds which have the same chemical formula but different ways of attachment of ligands are called as
- b. Structural isomerism is also known as isomerism.
- c. Complexes having ambidentate ligands show isomerism.
- d. $[Co(H_2O)_5Br]Cl$ shows isomerism.
- e. The compounds in which both the cationic and anionic species are complex ions, show isomerism.
- f. In isomerism, there is exchange between water molecule inside the coordination sphere and ions present in crystal lattice.
- g. isomerism occurs in bridge compounds.
- h. Stereoisomerism is also known as isomerism.
- i. *cis-trans* isomerism is also known as isomerism.
- j. geometrical isomers are possible for $[Pd(NH_3)_2(NO_2)_2]$.
- k. The three similar atoms or groups placed in a plane passing through metal atom/ ion give rise to isomer called as isomer.

- l. The optically active compounds are also called as optical isomers or or
- m. The compounds that cannot rotate the plane of polarized light are called as or
- n., an inorganic stereoisomer, is a chemotherapy drug used for the treatment of ovarian and testicular cancers.
- o. *trans*-platin, is in nature.
- p. μ is moment.
- q. $[\text{NiCl}_4]^{2-}$ is in shape.
- r. sp^3d^2 is the hybridization of central metal atom/ ion in shell orbital complex.

7.7.3 Short answer questions

- i. What is the coordination isomer of $[\text{Co}(\text{NH}_3)_6][\text{Cr}(\text{CN})_6]$?
- ii. Write the corresponding ionization isomer of $[\text{Co}(\text{H}_2\text{O})_5\text{Br}]\text{Cl}$.
- iii. Write the structure of corresponding hydrate isomer of $[\text{Cr}(\text{H}_2\text{O})_6]\text{Cl}$.
- iv. Give one example of ligand isomerism.
- v. Explain in brief coordination isomerism.
- vi. What are the different methods for identification of structural isomers?
- vii. What is stereoisomerism?
- viii. Write down the structure of geometrical isomers of $[\text{Pt}(\text{NH}_3)_2\text{Cl}_2]$.
- ix. How many isomers are possible for $[\text{Ma}_3\text{b}_3]^{n\pm}$ complex?
- x. Define the term enantiomer.
- xi. Write the corresponding optical isomers for $[\text{M}(\text{AB})_2]^{n\pm}$.
- xii. What are chiral compounds?
- xiii. Which of the following complexes are optically active?
(a) $[\text{Cr}(\text{ox})_3]^{3-}$; (b) *cis*- $[\text{PtCl}_2(\text{en})]$; (c) *fac*- $[\text{Co}(\text{NO}_2)_3(\text{py})_3]$; (d) *mer*- $[\text{Co}(\text{NO}_2)_3(\text{py})_3]$; (e) *cis*- $[\text{Co}(\text{C}_2\text{O}_4)(\text{NH}_3)_2(\text{NO}_2)_2]$; (f) *trans*- $[\text{Co}(\text{C}_2\text{O}_4)(\text{NH}_3)_2(\text{NO}_2)_2]$
- xiv. Identify the type of compounds showing geometrical isomerism:
(a) $[\text{Ma}_5\text{b}]^{n\pm}$; (b) $[\text{Ma}_3\text{b}_3]^{n\pm}$; (c) $[\text{Mabcdef}]^{n\pm}$; (d) $[\text{M}(\text{AB})_3]^{n\pm}$; (e) $[\text{Ma}_2\text{bc}]^{n\pm}$; (f) $[\text{M}(\text{AB})_2]^{n\pm}$; (g) $[\text{Ma}_3\text{b}]^{n\pm}$
- xv. List the methods used for identification of stereoisomers?
- xvi. What type of isomers are the following?

- (a) $[\text{Co}(\text{NH}_3)_5\text{NO}_2]^{2+}$ and $[\text{Co}(\text{NH}_3)_5\text{ONO}]^{2+}$
- (b) $[\text{Zn}(\text{NH}_3)_4][\text{CuCl}_4]$ and $[\text{Cu}(\text{NH}_3)_4][\text{ZnCl}_4]$
- (c) $[\text{Cr}(\text{H}_2\text{O})_5\text{Cl}]\text{Cl}_2 \cdot \text{H}_2\text{O}$ and $[\text{Cr}(\text{H}_2\text{O})_4\text{Cl}_2]\text{Cl} \cdot 2\text{H}_2\text{O}$
- (d) $[\text{Co}(\text{pn})_2\text{Cl}_2]^+$ and $[\text{Co}(\text{tn})_2\text{Cl}_2]^+$
- (e) *cis*- $[\text{Pd}(\text{NH}_3)_2(\text{NO}_2)_2]$ and *trans*- $[\text{Pd}(\text{NH}_3)_2(\text{NO}_2)_2]$
- (f) *d*- $[\text{Co}(\text{en})_2\text{C}_2\text{O}_4]^{+1}$ and *l*- $[\text{Co}(\text{en})_2\text{C}_2\text{O}_4]^{+1}$
- xvii. Draw all the possible isomers of $[\text{M}(\text{AA})_2\text{a}_2]^{n\pm}$ type complex.
- xviii. Draw all isomers of an octahedral complex having six unidentate ligands; three of type “a” and three of type “b”.
- xix. Define chirality.
- xx. What is plane of symmetry?
- xxi. What are the full forms of *d* and *l*?
- xxii. What do you mean by *cis*-isomer?
- xxiii. What do you mean by *trans*-isomer?
- xxiv. Which kind of ligands shows linkage isomerism?
- xxv. Write down the ionization products of $[\text{Co}(\text{NH}_3)_5\text{Br}]\text{SO}_4$ and $[\text{Co}(\text{NH}_3)_5\text{SO}_4]\text{Br}$ compounds.
- xxvi. How many molecules of AgCl will be produced by $[\text{Cr}(\text{H}_2\text{O})_6]\text{Cl}_3$, $[\text{Cr}(\text{H}_2\text{O})_5\text{Cl}]\text{Cl}_2 \cdot \text{H}_2\text{O}$ and $[\text{Cr}(\text{H}_2\text{O})_4\text{Cl}_2]\text{Cl} \cdot 2\text{H}_2\text{O}$ compounds, respectively on reaction with AgNO_3 ?
- xxvii. Ambidentate ligands show which kind of isomerism?
- xxviii. Which type of compounds show coordination position isomerism?
- xxix. What is the other name of stereoisomerism?
- xxx. Explain why tetrahedral complexes are not able to exhibit geometrical isomerism?
- xxxi. What are outer shell complexes?
- xxxii. How much unpaired electrons are present in $[\text{CoF}_6]^{3-}$?

7.8 BIBLIOGRAPHY

1. Br. R. Puri, L. R. Sharma and K. C Kalia. *Principles of Inorganic Chemistry*, Milestone Publishers & Distributors, Meerut, 2013.
2. http://chemwiki.ucdavis.edu/Inorganic_Chemistry/Coordination_Chemistry/Isomers/Geometric_Isomers%3A_cis-platin?

3. <https://people.ok.ubc.ca/wsmcneil/enants.htm>
4. M. S. Yadav. *Quick Review in Inorganic Chemistry*, Anmol Publications Pvt. Ltd., New Delhi, 2004.
5. P. Mishra *Advanced Inorganic Chemistry*, Jagdamba Publishing Compan, New Delhi, 2011.
6. R. Gopalan, and V. Ramalingam. *Concise Coordination Chemistry*, Vikas Publishing House Pvt Ltd., New Delhi, 2005.
7. R. L. Madan, *Chemistry for degree students, B.Sc. II year*, S. Chand & Company Ltd., New Delhi, 2011.
8. S. Prakash, G. D. Tuli, S. K. Basu, and R. D. Madan. *Advanced Inorganic Chemistry*, Vol. II, S. Chand & Company Ltd., New Delhi, 2007.
9. W. U. Malik, G. D. Tuli, and R. D. Madan. *Selected Topics in Inorganic Chemistry*, S. Chand Publication, Delhi, 2013.
10. J. D. Lee. *Concise Inorganic Chemistry*, Fifth Edition, Blackwell Science, USA, 1999.

7.9 LONG ANSWER QUESTIONS

- a. What do you mean by isomerism? Explain structural isomerism in detail with suitable examples.
- b. Define the term stereoisomerism. How it is important in human life?
- c. What is geometrical isomerism? What type of coordination compounds exhibit geometrical isomerism?
- d. Explain optical isomers of six coordinated compounds with suitable examples.
- e. With the help of suitable examples, explain the classification of isomerism in coordination compounds. Explain optical isomerism in four coordinated compounds.
- f. Write notes on the followings:
 - Coordination isomers
 - Linkage isomers
 - Ligand isomers
 - Geometrical isomerism in four coordinated compounds
- g. Draw all possible geometrical and optical isomers for $[\text{Mabcdef}]^{n\pm}$ complex.

- h. Sketch the isomers of both tetrahedral and square planar complexes which have two types of unidentate ligands (two unidentate ligands of each type).
- i. Explain valence bond theory with especial reference to octahedral complexes.
- j. With the help of suitable examples, explain bonding, magnetic properties and structure of $[\text{MnCl}_4]^{2-}$, $[\text{Ni}(\text{CN})_4]^{2-}$ and $[\text{CoF}_6]^{3-}$.

7.10 ANSWERS TO SHORT ANSWER QUESTIONS

State True (T) or False (F)

- a. T
- b. T
- c. T
- d. F
- e. T
- f. F
- g. T
- h. T
- i. T
- j. F
- k. F
- l. F
- m. T
- n. T
- o. T
- p. T
- q. F
- r. T
- s. T
- t. T
- u. T
- v. T

Fill in the blanks

- a. structural isomerism
- b. constitutional

- c. linkage
- d. ionization
- e. coordination
- f. hydrate
- g. Coordination position
- h. space
- i. geometrical
- j. Two
- k. meridional
- l. enantiomers or enantiomorphs
- m. optically inactive or racemic mixture
- n. cisplatin
- o. toxic
- p. magnetic
- q. tetrahedral
- r. outer

Short answer questions

- i. $[\text{Cr}(\text{NH}_3)_6][\text{Co}(\text{CN})_6]$
- ii. $[\text{Co}(\text{H}_2\text{O})_5\text{Cl}]\text{Br}$
- iii. $[\text{Cr}(\text{H}_2\text{O})_5\text{Cl}]\text{H}_2\text{O}$
- iv.

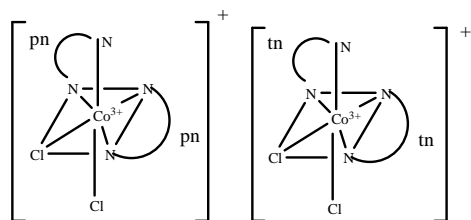

- v. The coordination compounds in which both the cationic and anionic species are complex ions, show coordination isomerism. This isomerism occurs by the interchange of ligands in between the cationic part and the anionic part.
- vi. (A) Conductivity method (Ionization isomers and hydrate isomers)
 (B) Electrolysis method (Coordination isomers)
 (C) Freezing point depression method (Hydrate isomers)

(D) Infrared spectroscopy (Linkage isomers)

vii. Compounds which have the same atoms/ groups, same position of atoms/ groups and same sets of bonds, but differ in their spatial arrangement around the central atom/ ion are called as stereoisomers and the phenomenon is known as stereoisomerism.

viii.

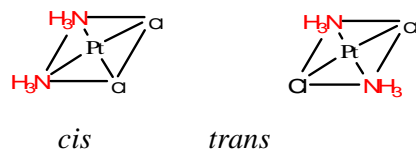

ix. Two geometrical isomers- *mer* and *fac*

x. Optically active compounds which are nonsuperimposable mirror image of each other are called as enantiomer.

xi.

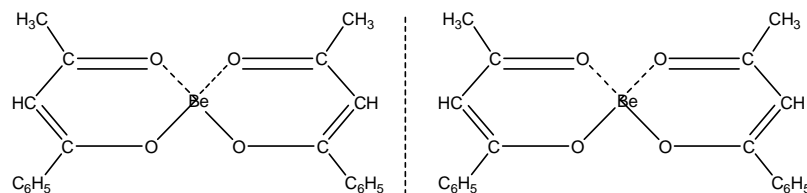

xii. The compounds which cannot be divided into two equal parts when cut through an imaginary plane (mirror plane) are called as chiral.

xiii.

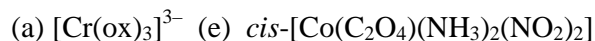

xiv.

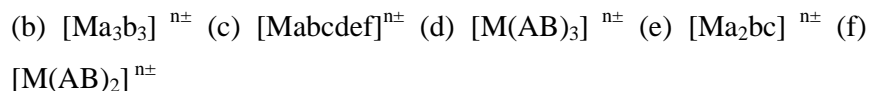

xv. (A) Dipole moment method (*cis* and *trans* isomers)

(B) Nuclear Magnetic Resonance (NMR) Spectroscopy (*cis* and *trans* isomers)

(C) Greinberg's method (*cis* and *trans* isomers)

(D) Mass spectrometry (both optical and *cis* and *trans* isomers)

(E) Infrared Spectroscopy (*cis* and *trans* isomers)

xvi.

- (a) Linkage
- (b) Coordination
- (c) Hydrate
- (d) Ligand
- (e) Geometrical
- (f) Optical

xvii.

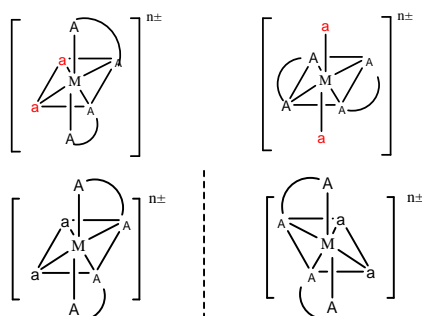

Geometrical isomers

Optical isomers

xviii.

fac-isomer

mer-isomer

- xix. Optical isomers have same physical and chemical properties but have different property with respect to the rotation of the plane of polarized light and the isomerism possessed by these isomers is called as chirality.
- xx. Plane of symmetry is an imaginary plane that divides a compound into two equal halves which are mirror images of each other.
- xxi. Dextrorotatory and laevorotatory
- xxii. When similar atoms/ groups (ligands) are adjacent to each other, the isomer is called *cis*-isomer.
- xxiii. In *trans*-isomer, the similar ligands are present diagonally opposite to each other.

- xxiv. Ambidentate ligands.
- xxv. $[\text{Co}(\text{NH}_3)_5\text{Br}]^{2+}$ and SO_4^{2-} ; $[\text{Co}(\text{NH}_3)_5\text{SO}_4]^+$ and Br^- compounds.
- xxvi. 3, 2, 1 respectively.
- xxvii. Linkage isomerism
- xxviii. Bridged compounds
- xxix. Space isomerism
- xxx. Tetrahedral (coordination number 4) complexes do not show geometrical isomerism because in this geometry, all the ligands are present in *cis*. position (adjacent) with respect to each other (all bond angles are same).
- xxxi. The complexes in which outer shell d-orbitals are used in hybridization, it is called as outer shell complex.

UNIT 8- OXIDATION AND REDUCTION

CONTENTS:

- 8.1 Objectives
- 8.2 Introduction
 - 8.2.1 Oxidation (De-electronation)
 - 8.2.2 Reduction (Electronation)
 - 8.2.3 Oxidation Number
 - 8.2.4 Electrode potential (E)
- 8.3 Uses of redox potential data
 - 8.3.1 To know feasibility of a chemical reaction
 - 8.3.2 To calculate redox potential and free energy change
 - 8.3.3 To calculate the value of reduction electrode potential of a given electrode at non-standard condition
 - 8.3.4 To calculate the value of e.m.f. of a given cell at standard conditions
 - 8.3.5 To calculate the value of E_{cell} by using Nernst equation
 - 8.3.6 To know oxidizing and reducing property of substances in aqueous solution
 - 8.3.7 To calculate redox potential and equilibrium constant
- 8.4 Analysis of redox cycles
 - 8.4.1 Oxidation cycle of alkali metals
 - 8.4.2 Reduction cycle of halogens
- 8.5 Redox stability of water
 - 8.5.1 The compound may release H_2 on reaction with water
 - 8.5.2 The compound can release O_2 on reaction with water
- 8.6 Latimer, Frost, Ebsworth and Pourbaix diagrams
 - 8.6.1 Latimer diagram
 - 8.6.2 Frost diagram
 - 8.6.3 Ebsworth diagram
 - 8.6.4 Pourbaix diagram
- 8.7 Principles involved in the extraction of elements
 - 8.7.1 Thermodynamic principle of reduction of metal oxides to metals by carbon (C(s) or CO(g))
 - 8.7.2 Reduction of a metal oxide by another metal

- 8.8 Summary
- 8.9 Terminal questions
 - 8.9.1 Fill in the blanks
 - 8.9.2 State True (T) or False (F)
 - 8.9.3 Long answer questions
- 8.10 Answers
 - 8.10.1 Fill in the blanks
 - 8.10.2 True (T) or False (F)

8.10 OBJECTIVES

This unit deals with the oxidation-reduction processes, different terminologies involved and their application. When you study this unit, you will be able to identify, understand and answer the following terms and problems:

- Oxidation,
- Reduction,
- Oxidation number,
- Standard potential,
- Electrochemical series,
- Redox cycles,
- Latimer, Frost and Pourbaix diagram,
- Extraction of elements and redox reactions,

And you can also get acquainted with the following terms:

- Oxidizing agent,
- Reducing agent,
- Redox reactions,
- Redox Potential

8.2. INTRODUCTION

We all know that oxidation-reduction processes occur in our daily life. The various examples of oxidation-reduction reactions in our day-to-day life are rusting of iron, use of lead acid batteries in inverters and other batteries used for different purposes, photosynthesis, respiration and combustion. In redox reactions, oxidation number of molecule, atom or ion (any species) changes by transfer of electrons (gain or loss of electrons).

The redox reactions involve two half reactions, a reduced half and an oxidized half and these two always occur together. The reduced half reaction gains electrons and called as oxidizing agent while the oxidation half is called as reducing agent. There are different definitions and phenomena given for oxidation and reduction reactions. Here, in this unit, we will discuss the different aspects of redox reactions.

8.2.1. Oxidation number

In case of ionic reactions, redox changes can be explained in terms of electron transfer. However, in the case of covalent compounds, the redox reactions can be explained on the basis of oxidation number. The oxidation number is a measure of extent of oxidation (charge which appears when the other atoms are removed) of an element and in its compounds.

8.2.2. Oxidation (De-electronation)

The process in which loss of electrons results in the increase in oxidation number of its atom / atoms is called oxidation reaction.

Oxidizing agent (O.A.)

It accepts electrons (electron acceptor) or oxidation number of whose atoms or ions decreases.

8.2.3. Reduction (Electronation)

Gain of electron or decrease in oxidation number of its atom / atoms is known as reduction.

Reducing agent (R.A.)

It donates electrons (electron donor) or oxidation number of whose atoms increases.

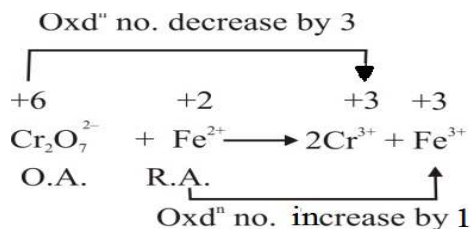

Here, oxidation of Fe and reduction of Cr takes place.

Oxidizing agent – $\text{Cr}_2\text{O}_7^{2-}$

Reducing agent – Fe^{2+}

Thus, a reduction-oxidation (redox) reaction is a chemical reaction which comprises transfer of electrons between two species viz. oxidizing agent and reducing agent.

8.2.4. Oxidation Number

It is the charge which an atom of an element has in its ion or appears to have when present in the combined state. It is also known as oxidation state.

8.2.5. Electrode potential (E)

In metal-metal ion electrode, metal (M) immersed in the solution containing metal ions (M^{n+} ions). In the electrode, there exists a separation of charges between the metal and its salt solution. The separation of charges results in the development of net (-)ve or (+)ve charge on the metal with respect to its solution. The (-)ve or (+)ve charge developed on the metal produces electrical potential difference between the metal and its solution. This electrical potential difference is called potential of the electrode or electrode potential. Electrode potential is a measure of the tendency of an electrode in a half-cell reaction to gain or lose electrons. It is denoted by E. Unit of electrode potential is volt (V). Volt is the potential, required to flow one coulomb of electric current per second, through a uniform thread of mercury 106.3 cm long, containing 14.4521 g of mercury at 0°C.

Standard electrode potential (E°)

When the concentration of the ions and the pressure of the gaseous species appearing in the electrode reaction (half-cell reaction) are 1 mol dm^{-3} and 1 atmosphere, respectively at 25°C temperature, the electrode potential is called standard electrode potential. It is denoted by E° .

Types of electrode potential

Electrode potential may be of following types:-

8.2.5.1. Oxidation electrode potential (E°_{ox})

Oxidation potential of an electrode is for the oxidation reaction taking place at the anode. Thus, oxidation electrode potential is the potential of the electrode at which oxidation takes place and hence, is a measure of the tendency of the electrode in a half-cell to get oxidized or to lose electrons.

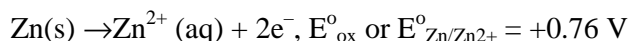

8.2.5.2. Reduction electrode potential, (E°_{red})

Reduction potential of an electrode is for the reduction reaction taking place at the electrode. Thus reduction electrode potential is the potential of the electrode at which reduction takes place and hence is a measure of the tendency of the electrode in a half-cell to get reduced or to gain electrons.

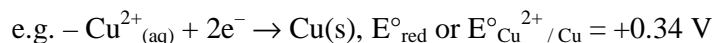

Relation between oxidation potential and reduction potential of a given electrode

$$(E_{\text{ox}})_{\text{elec.}} = - (E_{\text{red}})_{\text{elec.}}$$

$$- (E_{\text{ox}})_{\text{elec.}} = (E_{\text{red}})_{\text{elec.}}$$

Similarly, for standard electrode potentials –

$$(E^{\circ}_{\text{ox}})_{\text{elec.}} = - (E^{\circ}_{\text{red}})_{\text{elec.}}$$

$$- (E^{\circ}_{\text{ox}})_{\text{elec.}} = (E^{\circ}_{\text{red}})_{\text{elec.}}$$

An important convention

According to the present convention, the value of electrode potential is expressed as reduction electrode potential. Thus, if we say that the value of standard electrode potential of zinc electrode is -0.76 volt, this means that the given value is the value of the standard reduction electrode potential of Zn electrode, i.e., $E_{\text{Zn}^{2+}/\text{Zn}} = -0.76$ volt

8.3 USE OF ELECTRODE POTENTIAL DATA - ELECTROCHEMICAL SERIES

The values of standard reduction potentials of many electrodes have been determined at 25°C or $(25 + 273) = 298\text{K}$. These values have been arranged in their increasing order, in the form of a series, which is called electrochemical series.

Reducing \rightleftharpoons Oxidizing + e^{-} E° (V)
agent agent

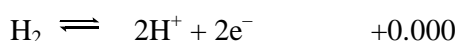
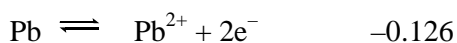
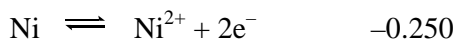
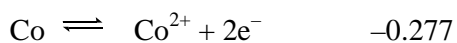
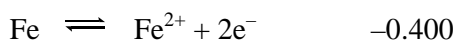
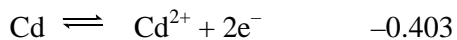
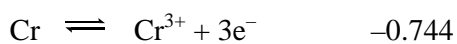
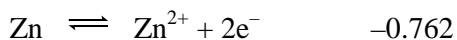
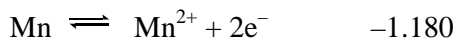
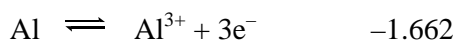
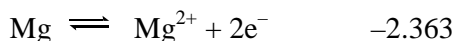
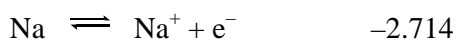
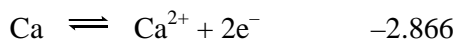
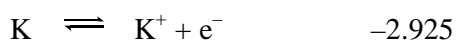
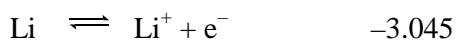

$\text{CH}_4 \rightleftharpoons \text{C} + 4\text{H}^+ + 4\text{e}^-$	+0.132
$\text{Cu}^+ \rightleftharpoons \text{Cu}^{2+} + \text{e}^-$	+0.153
$\text{Cu} \rightleftharpoons \text{Cu}^{2+} + 2\text{e}^-$	+0.337
$2\text{OH}^- \rightleftharpoons \frac{1}{2}\text{O}_2 + \text{H}_2\text{O} + 2\text{e}^-$	+0.401
$\text{I}^- \rightleftharpoons \frac{1}{2}\text{I}_2 + \text{e}^-$	+0.536
$\text{Fe}^{2+} \rightleftharpoons \text{Fe}^{3+} + \text{e}^-$	+0.771
$\text{Ag} \rightleftharpoons \text{Ag}^+ + \text{e}^-$	+0.799
$\text{Hg} \rightleftharpoons \text{Hg}^{2+} + 2\text{e}^-$	+0.854
$\text{Hg}_2^{2+} \rightleftharpoons 2\text{Hg}^{2+} + 2\text{e}^-$	+0.908
$\text{Pd} \rightleftharpoons \text{Pd}^{2+} + 2\text{e}^-$	+0.987
$\text{Br}^- \rightleftharpoons \frac{1}{2}\text{Br}_2 + \text{e}^-$	+1.065
$\text{Pt} \rightleftharpoons \text{Pt}^{2+} + 2\text{e}^-$	+1.200
$\text{Cl}^- \rightleftharpoons \frac{1}{2}\text{Cl}_2 + \text{e}^-$	+1.359
$\text{Au}^+ \rightleftharpoons \text{Au}^{3+} + 2\text{e}^-$	+1.402
$\text{Au} \rightleftharpoons \text{Au}^{3+} + 3\text{e}^-$	+1.498
$\text{Pb}^{2+} \rightleftharpoons \text{Pb}^{4+} + 2\text{e}^-$	+1.800
$\text{Ag}^+ \rightleftharpoons \text{Ag}^{2+} + \text{e}^-$	+1.980
$\text{F}^- \rightleftharpoons \frac{1}{2}\text{F}_2 + \text{e}^-$	+2.870
$\text{HF}_{(\text{aq})} \rightleftharpoons \frac{1}{2}\text{F}_2 + \text{H}^+ + \text{e}^-$	+3.060

Reducing property

The potential data can be utilized for the following purposes:

8.3.1 To know the feasibility of a chemical reaction

With the help of potential data, we can determine the feasibility of a redox reaction. The electric pressure that makes current flow in a circuit is called as electromotive force.

$$\begin{aligned} \text{Electromotive force (E.M.F.)} &= E^\circ_{\text{cathode}} - E^\circ_{\text{anode}} \\ &= E^\circ_{\text{more}} - E^\circ_{\text{less}} \\ &= E^\circ_{\text{right}} - E^\circ_{\text{left}} \end{aligned}$$

Suppose, we want to know feasibility of the following redox reaction:

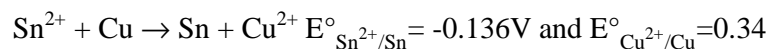

As reduction potential of $E^\circ_{\text{Cu}^{2+}/\text{Cu}}$ is higher as compared to $E^\circ_{\text{Sn}^{2+}/\text{Sn}}$ the oxidation potential, reduction will take place at copper half cell. But in this reaction, the two reaction halves are:

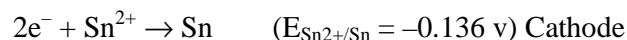

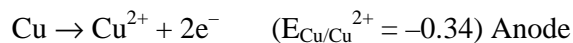

$$\text{E.M.F.} = E_{\text{cathode}} - E_{\text{anode}}$$

$$= -0.136 - (+0.34)$$

$$= -0.476\text{V}$$

Due to negative value of E.M.F. of the cell, it is not a feasible cell. Whereas if the cell reaction is

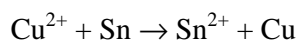

Then, it will be feasible to occur, because now E.M.F. will be positive.

$$E^{\circ}_{\text{cell}} = E^{\circ}_{\text{cathode}} - E^{\circ}_{\text{anode}}$$

If we know $E^{\circ}_{\text{cathode}}$ and E°_{anode} , we can easily calculate K. If K is very high, the reaction will proceed towards forward direction.

8.3.2 To calculate the redox potential and free energy change

There is the following relationship between E° and free energy change (ΔG°):

$$\Delta G^{\circ} = -nE^{\circ}F$$

If E° is positive, the value of ΔG° will be negative and a reaction is generally thermodynamically feasible if value of ΔG° is negative.

8.3.3 To calculate the value of reduction electrode potential of a given electrode in non-standard conditions

The value of $(E_{\text{red}})_{\text{elec}}$ can be calculated by using the following Nernst

Equation:

$$(E_{\text{red}})_{\text{elec}} = (E^{\circ}_{\text{red}})_{\text{elec}} - \frac{2.303 RT}{nF} \log \frac{\text{Product of concentration of products}}{\text{Product of concentration of reactants}}$$

Here, $(E_{\text{red}})_{\text{elec}}$ = Reduction electrode potential in non-standard conditions,

$(E^{\circ}_{\text{red}})_{\text{elec}}$ = Reduction electrode potential in standard conditions, i.e.

(E°_{red}) is the standard electrode potential,

n = no. of electrons released in the electrode reduction reaction.

8.3.4 To calculate the value of potential (e.m.f.) of a given cell in standard conditions

The value of E°_{cell} can be calculated by using the equation

$$E^{\circ}_{\text{cell}} = (E^{\circ}_{\text{red}})_{\text{cathode}} - (E^{\circ}_{\text{red}})_{\text{anode}}$$

8.3.5 To calculate the value of E_{cell} by using Nernst equation

$$E_{\text{cell}} = E_{\text{cell}}^{\circ} - \frac{2.303 RT}{nF} \log \frac{\text{Product of concentration of products}}{\text{Product of concentration of reactants}}$$

8.3.6. To know oxidizing and reducing property of substances in aqueous solution

The substance which has a (+)ve value of E_{red}° , has a tendency to gain electrons to undergo reduction and hence is capable of acting as an oxidizing agent in aqueous solution. The substance which has a (-)ve value of E_{red}° , has a tendency to lose electrons to undergo oxidation and hence is capable of acting as a reducing agent in aqueous solution. Higher the value of E_{red}° , higher the tendency of the substance to accept electrons to undergo reduction in aqueous solution and hence higher the oxidizing power of the substance. Higher the value of E_{red}° , lower is the tendency of a substance to lose electrons to undergo oxidation in an aqueous solution and hence lower is the reducing power of the substance. Since, E_{red}° value increases down the electrochemical series ($- \rightarrow O \rightarrow +$), the oxidizing power of oxidizing agents also increases. Since, E_{red}° value increases down the electro-chemical series, the reducing power of the reducing agents decreases in the series.

8.3.7. To calculate redox potential and equilibrium constant

As redox reactions are reversible in nature, therefore, there is equilibrium between oxidizing and reducing agent. If we know the redox potential, we can calculate equilibrium constant for the reaction which can further decide the direction of the reaction forward / backward $\text{Zn}_{(\text{s})} + \text{Cu}_{(\text{aq})}^{2+} \rightleftharpoons \text{Zn}_{(\text{aq})}^{2+} + \text{Cu}_{(\text{s})}$.

$$\text{(Equilibrium constant) } K = \frac{[\text{Zn}^{2+}] [\text{Cu}_{(\text{s})}]}{[\text{Zn}_{(\text{s})}] [\text{Cu}^{2+}]}$$

As concentration of solids remains constant, $[\text{Cu}_{(\text{s})}]/[\text{Zn}_{(\text{s})}]$ will be constant (I) So,

$$K = \frac{[\text{Zn}^{2+}]}{[\text{Cu}^{2+}]}$$

K is related to E.M.F. of a cell by the following relation :

$$E_{\text{cell}}^{\circ} = \frac{2.303RT}{nF} \log K \text{ and at } 25^{\circ}\text{C} = 0.059/n \log K.$$

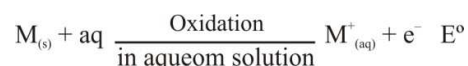
8.4. ANALYSIS OF REDOX CYCLE**8.4.1. Oxidation cycle for alkali metals**

Tendency of a metal electrode to release e^- is known as standard oxidation potential.

This reaction can occur by three different steps also:

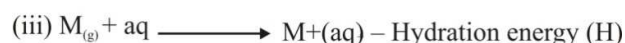
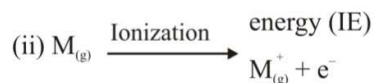

Hence, electrode potential of the metal depends upon sublimation energy, ionization energy and hydration energy, i.e.,

$$E^\circ_{\text{ox}} = S + IE + H$$

In case of alkali metals, especially Li, sublimation energy is very less and ionization energy is also very low, but hydration energy is very high. Hence, Li has the highest positive value of E_{ox} (+3.04 V).

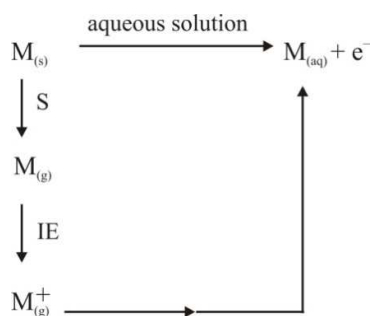

Oxidation cycle of metals

8.4.2. Reduction cycle of halogens

The tendency of halogens to accept electron in aqueous solution to form hydrated ion ($X^-(aq)$) is the standard reduction potential (E°_{red})

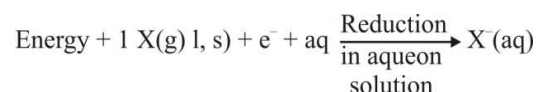

This process also involves three /four/five steps :

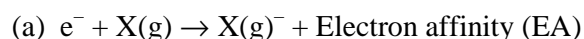
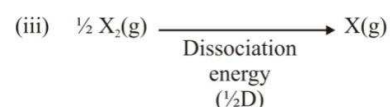
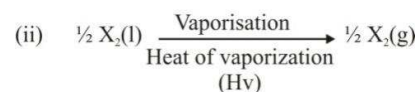
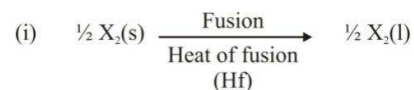

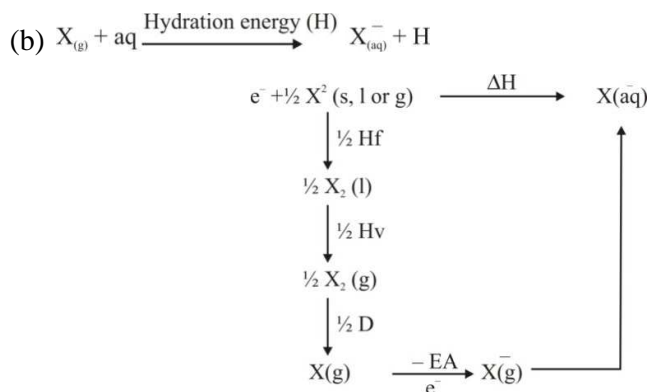

Reduction cycle of halogens

$$E_{\text{red}}^{\circ} = \frac{1}{2}H_f + \frac{1}{2}H_v + \frac{1}{2}D + EA + H$$

As F_2 and Cl_2 are gas, H_f and H_v can be omitted. In the similar way, heat of fusion (H_f) can be omitted for Br_2 (liquid). After putting all the values of energy, we get

E_{red}° values as follows:

$$F_2 = -768 \text{ (kJ/mole)}$$

$$Cl_2 = -607 \text{ (kJ/mole)}$$

$$Br_2 = -575 \text{ (kJ/mole)}$$

$$I_2 = -494 \text{ (kJ/mole)}$$

These values suggest that, in spite of lower electron affinity of F_2 , its E_{red}° is higher as compared to that of Cl_2 . Hence, F_2 is more powerful oxidizing agent than Cl_2 . Therefore, oxidizing power of halogens in aqueous solution does not depend on the value of EA but on the value of E_{red}° .

8.5. REDOX STABILITY OF WATER

The compounds that are stable in water neither oxidize nor reduce or disproportionate in water (Figure 8.1). While, the substances, which are unstable in water, they can undergo the following reactions in aqueous medium:

8.5.1 The compound may release H_2 on reaction with water

In these reactions, water is reduced to H_2 .

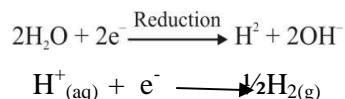

This reaction is shown by some alkali metals and elements of first series of transition elements like Sc, Ti, V, Cr, Mn, etc.

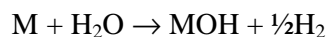

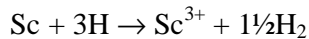

8.5.2 The compound can release O₂ on reaction with water

Here, water acts as an oxidizing agent:



Most of the species with more than 1.23V E°_{red} can oxidize water into O₂ such as F₂, Co³⁺, Ce⁴⁺ etc.

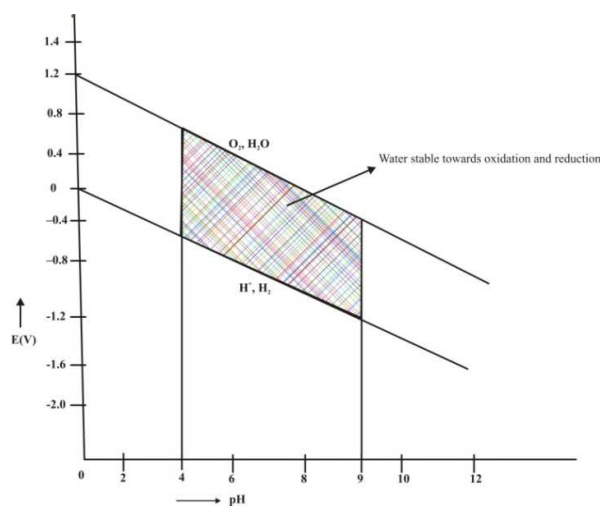
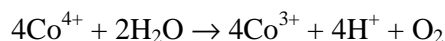
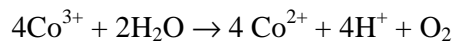

Figure 8.1: Redox stability of water

8.6 LATIMER, FROST AND POURBIX DIAGRAMS

8.6.1. Latimer diagram

Latimer diagram represents useful diagrammatic summaries of the relative stabilities of a series of species. The numerical value of standard potential is written over a horizontal line connecting species with the element in different oxidation states. The most highly oxidized form of the element is on the left, and to the right, the element is in successively lower oxidation states.

Latimer diagram of chlorine in an acidic solution

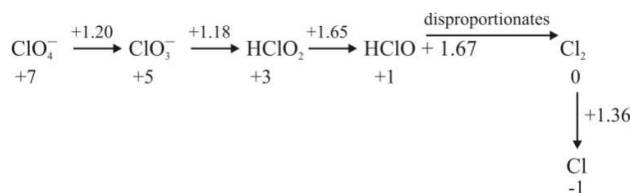

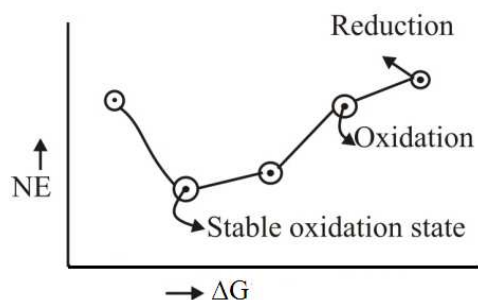

Figure 8.2: Frost diagram in general

A species in a Frost diagram is unstable with respect to disproportionation, if its point lies above the line connecting two adjacent species.

(3) N_2O_4 undergo disproportionation, Figure 8.3.

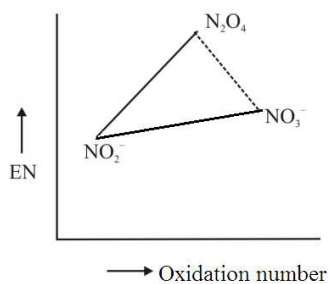

Figure 8.3: Frost diagram showing disproportionation of N_2O_4

Reverse of disproportionation is called comproportionation (Figure 8.4):



Two species will tend to comproportionate into an intermediate species that lies below the straight line joining the terminal species. Frost diagram showing comproportionation is given in Figure 8.4.

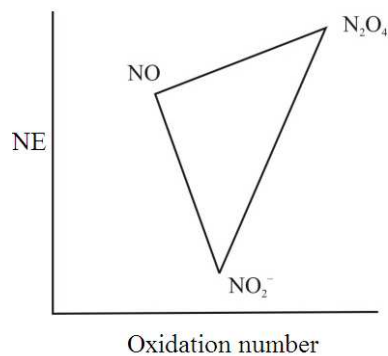

Figure 8.4: Frost diagram showing comproportionation

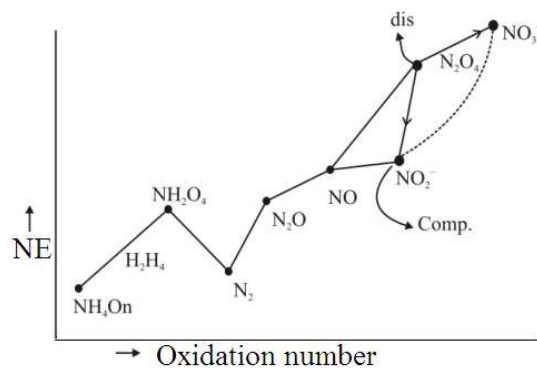
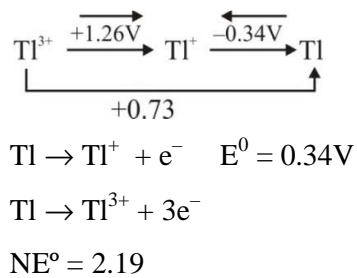

Figure 8.5: Frost diagram for nitrogen

Construction of Frost diagram from Latimer diagram (Figure 8.5.)



Thus, calculated NE along with oxidation can be plotted to get frost diagram.

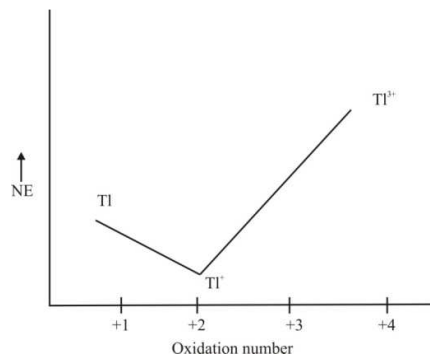
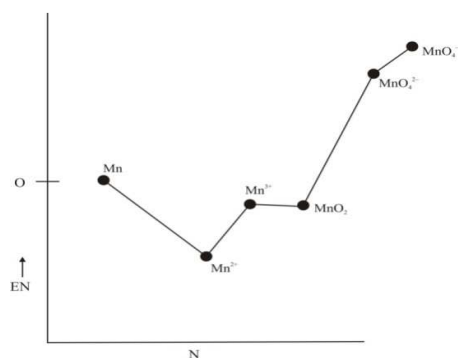
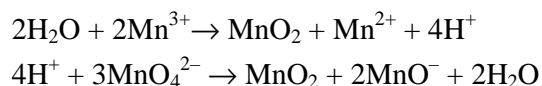
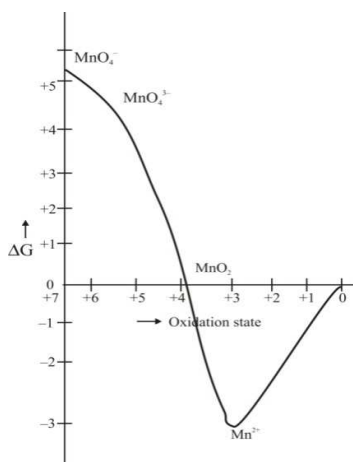

Figure 8.5: Construction of Frost diagram for thallium from Latimer diagram

Consider the Frost diagram for manganese in acidic medium (Figure 8.6). Mn(II) is the most stable oxidation state. Mn^{3+} and MnO_4^{2-} are unstable and undergo disproportionation because both Mn^{3+} and MnO_4^{2-} species lie above the line joining Mn^{2+} and MnO_2 and MnO_2 and MnO_4^- , respectively. Thus, disproportionate into the respective species (Figure 8.6).

**Figure 8.6: Frost diagram for manganese in acidic medium****8.6.3. Ebsworth diagram**

Free energy is plotted along the vertical axis against oxidation states horizontal axis. The free energy changes between oxidation states are readily calculated from reduction potential. The lower oxidation state in the diagram is stable oxidation state. Mn^{3+} more stable than MnO_4^- but not than Mn^{2+} (Figure 8.7).

**Figure 8.7.** Ebsworth diagram of manganese: Free energies of oxidation states of manganese relative to oxidation state of the metal in aqueous solution at pH = 0.

8.6.4. Pourbaix diagram: Possible stable phases of an aqueous electrochemical system

Potential / pH diagrams are called as Pourbaix diagrams (Figure 8.8).

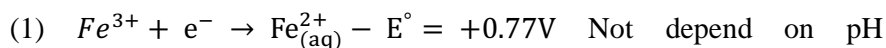

(Horizontal line)

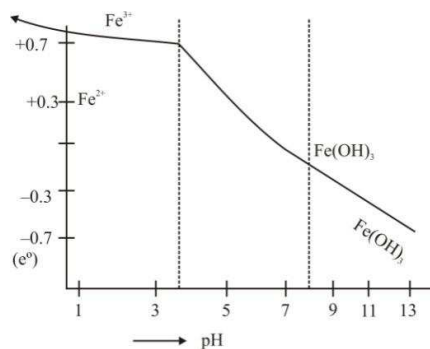
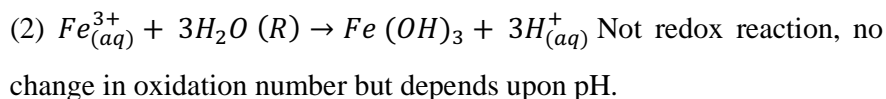
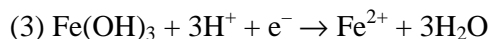

Figure 8.8: Pourbaix diagram of iron



pH increases, potential will change negatively.

Disproportionation reactions

These are the redox reactions in which the oxidation number of a species can increase and decrease simultaneously.

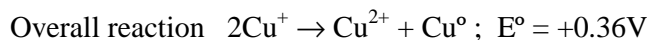
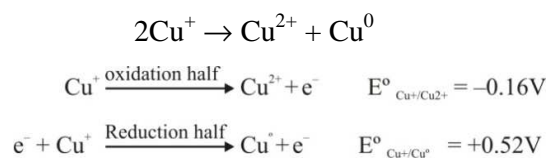

E° is positive, hence the reaction is feasible.

Redox stability of water depends upon pH value. The species with E° values greater than $[1.23\text{V} - (0.591\text{pH})\text{V}]$ can oxidize H_2O to O_2 and the species whose E° value is more negative than $(-0.0591\text{pH})\text{V}$ can reduce H^{+} to H_2 .

Comproportionation reaction

This reaction is opposite of disproportionation reaction and in this two oxidation states convert into only one oxidation state:

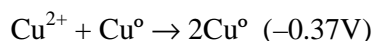

Autooxidation

It is same as disproportionation reaction but it occurs slowly without the action of heat, light or electricity:

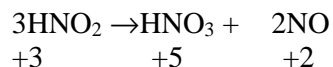

8.7 PRINCIPLES INVOLVED IN THE EXTRACTION OF ELEMENTS

Gibbs free energy change (ΔG), entropy change (ΔS) and ΔH of a reaction are related as follows:

$$\Delta G = \Delta H - T\Delta S$$

From this equation, you can observe that if ΔS is positive, $T\Delta S$ will also increase and the value ΔG will be negative ($\Delta H < T\Delta S$). Thus, the reaction in the forward direction will occur spontaneously.

Equilibrium constant (K) and ΔG° are related as:

$$\Delta G^\circ = -RT \log K$$

From this equation, it can be concluded that higher the value of K , more negative will be the value of ΔG° and thus, the reaction will again proceed towards forward direction.

When ΔG for a reaction is positive, it can be proceeded spontaneously by coupling with another reaction with larger (in negative) ΔG value so that the resultant ΔG value should be negative. This type of coupling reactions can be better understood by Ellingham diagram.

8.7.1. Thermodynamic principle for the reduction of metal oxides to metal by carbon ($\text{C}_{(s)}$) or $\text{CO}_{(g)}$

Metal oxide on reduction with $\text{C}_{(s)}$ converts into $\text{CO}_{(s)}$ or $\text{CO}_{2(g)}$ as shown by the following redox reactions :

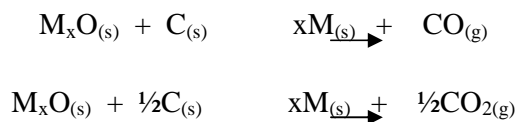

Conversion of $\text{C}_{(s)}$ to $\text{CO}_{(g)}$ and $\text{M}_{(s)}$ to $\text{M}_x\text{O}_{(s)}$ are oxidation reactions :

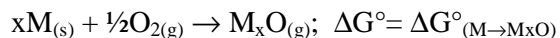
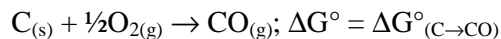

After subtracting these two equations, we get –

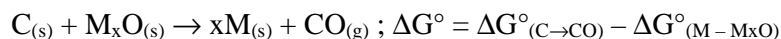

Hence, if $\Delta G^\circ_{(C \rightarrow CO)}$ is more negative as compared to $\Delta G^\circ_{(M \rightarrow M_xO)}$, then only the reaction is feasible. The other reaction where $C_{(s)}$ can be converted to $CO_{2(g)}$, similarly the $\Delta G^\circ_{(C \rightarrow CO_2)}$ should be more negative as compared to $\Delta G^\circ_{(M \rightarrow M_xO)}$ for reaction to occur spontaneously. In the similar way, we can understand the reaction of M_xO to xM on reaction with CO.

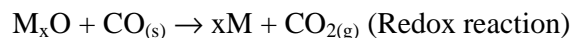

The two oxidation reactions of $CO_{(g)}$ and M are

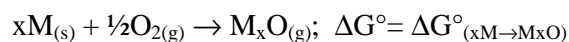
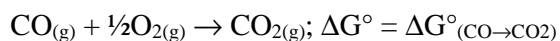

The overall free energy change will be

$$\Delta G^\circ_{(CO \rightarrow CO_2)} - \Delta G^\circ_{(M \rightarrow M_xO)}$$

If $\Delta G^\circ_{(CO \rightarrow CO_2)}$ will be more negative than $\Delta G^\circ_{(M \rightarrow M_xO)}$, the overall free energy change will also be negative and reduction of $M_x \rightarrow M$ with CO will be feasible.

8.7.2. Reduction of a metal oxide by another metal

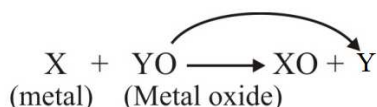

In the above reaction, X and Y are two different metals, while YO and XO are oxides of these metals.

Change in free energy = free energy change of products – free energy change of reactants

$$\text{Change in free energy of reaction} = \Delta G^\circ_{(X \rightarrow XO)} - \Delta G^\circ_{(YO \rightarrow Y)}$$

As X and Y are elemental form, the change in free energy of reaction becomes:

$$\Delta G^\circ_{(XO)} - \Delta G^\circ_{(YO)}$$

The $\Delta G^\circ_{(XO)}$ value should be negative so that the overall free energy change is negative.

8.8. SUMMARY

In this Unit, you have studied that

- Oxidation and reduction reactions occur simultaneously and are called redox reactions.

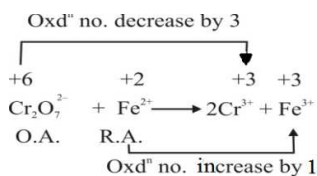

Here Fe^{2+} has been oxidized to Fe^{3+} while $\text{Cr}_2\text{O}_7^{2-}$ has been reduced to Cr^{3+} .

- Oxidation state or oxidation number of an element or an atom is the charge that appears when the particular element is present in the combined state.
- In oxidation reaction, loss of electron(s) or in the increase in oxidation number takes place.
- Oxidizing agent is the species that accepts electron/s and reduce itself.
- Reduction reaction is the process where either gain of electron/s or decrease in oxidation number is observed.
- Reducing agent is a species which donates electron/s and oxidize itself during the course of a redox reaction.
- The tendency of cathode to gain the electron/s is called reduction potential while the tendency of the other half electrode (anode) to lose the electron/s is called as oxidation potential. Reduction potential is denoted by E_{red} and oxidation potential by E_{ox} . If reduction / oxidation potential of a

compound is measured under standard conditions, then it is called as standard reduction (E°_{red})/standard oxidation potential (E°_{ox}).

- Electrochemical series is arrangement of standard oxidation potentials in their increasing order.
- The potential data can be utilized to know feasibility of a chemical reaction, to calculate redox potential and free energy change, to calculate the value of reduction potential of a given electrode at non standard conditions, to calculate e.m.f. of a given cell at standard conditions, to calculate the value of E_{cell} , to know the oxidizing and reducing property of substances in aqueous solution and to calculate equilibrium constant.
- Oxidation cycle of alkali metals and reduction cycle of halogens explain pattern of their reduction potential data.
- Redox stability of water explains stability or instability of certain species in water.
- Latimer diagrams show the standard reduction potentials connecting various oxidation states of an element in a horizontal line with the most oxidized form on the left and the elements with successive lower oxidation states on the right. Latimer diagram of chlorine in basic medium is given below:

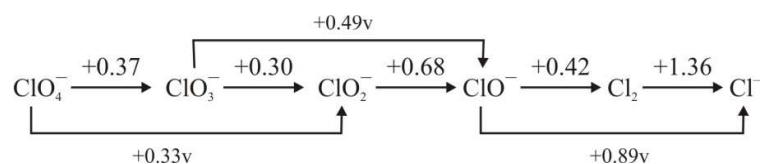

- Latimer diagram is useful to predict feasibility of a redox reaction, unstable species and help in calculating E° value for any non-adjacent couple.
- Frost diagrams are plot between NE° and oxidation state of an element. This diagram is helpful in predicting the most stable oxidation state of the element, unstable species and oxidizing power of coupled reactions. It also tells about the species which can disproportionate.
- Ebsworth diagrams are the plots between oxidation state and free energy.

- Pourbaix diagrams are plotted between potential and pH.
- Disproportionation reactions are redox reactions in which the oxidation number of a species increases and decreases simultaneously.
- Comproportionation reactions are opposite of disproportionation reactions in which two oxidation states converts into a single oxidation state.
- Autooxidation reaction is similar to disproportionation reaction but occurs without any external support like heat, light or electricity.
- Free energy change, entropy change and enthalpy change of a chemical reaction control extraction of elements during their metallurgy.

Bibliography

- m) Br. R. Puri, L. R. Sharma and K. C Kalia. *Principles of Inorganic Chemistry*, Milestone Publishers & Distributors, Meerut, 2013.
- n) G. S. Sodhi, *Textbook of Inorganic Chemistry*, Viva Books Private Limited, New Delhi, 2013.
- o) M. S. Yadav. *Quick Review in Inorganic Chemistry*, Anmol Publications Pvt. Ltd., New Delhi, 2004.
- p) P. Mishra, *Advanced Inorganic Chemistry*, Jagdamba Publishing Compan, New Delhi, 2011.
- q) R. L. Madan, *Chemistry for degree students, B.Sc. II year*, S. Chand & Company Ltd., New Delhi, 2011.
- r) S. Prakash, G. D. Tuli, S. K. Basu, and R. D. Madan. *Advanced Inorganic Chemistry*, Vol. I, S. Chand & Company Ltd., New Delhi, 2007.
- s) W. U. Malik, G. D. Tuli, and R. D. Madan. *Selected Topics in Inorganic Chemistry*, S. Chand Publication, Delhi, 2013.

8.9. Terminal questions

8.9.1. Fill in the blanks

- i. The redox reactions involve two half reactions, a half and an half and these two always occur together.
- ii. Charge that appears when the other atoms are removed is called as
- iii. The reaction in which, loss of electrons results in the increase in oxidation number of its atom / atoms is called reaction.
- iv. Gain of electron or decrease in oxidation number of its atom / atoms is known as

- v. is also known as oxidation state.
- vi. Electrode potential is a measure of the tendency of an electrode in a half-cell to or electrons.
- vii. potential is the potential of the electrode at which oxidation takes place and hence, is a measure of the tendency of the electrode in a half-cell to get oxidized or to lose electrons.
- viii. The values of Potentials have been arranged in their increasing order, in the form of a series, which is called electrochemical series.
- ix. Relationship between redox potential and free energy change is
- x. In diagrams numerical value of the standard potential is written over a horizontal line connecting species with the element in different oxidation state.
- xi. If sum of the reduction and oxidation potential is positive, then the standard free energy change for the will have a negative value and spontaneous is possible.
- xii. In diagram, free energy is plotted along the vertical axis against oxidation states horizontal axis.
- xiii. diagram is plot between potential and pH.
- xiv. Plot of product of oxidation state (N) and reduction potential (E°) against oxidation number of the element (N) or plot between standard Gibbs energy against oxidation number is diagram.
- xv. reaction is opposite of disproportionation reaction.
- xvi. It is same as disproportionation reaction but it occurs slowly without the action of heat, light or electricity is.....

8.9.2. State True (T) or False (F).

- i. Rusting of iron, use of lead acid batteries in inverters and other batteries used for different purposes, photosynthesis, respiration and combustion are the examples of oxidation-reduction reactions.
- ii. The reduction half reaction gains electrons and called as reducing agent while the oxidation half is called as oxidizing agent.
- iii. Redox reactions are reduction reactions.
- iv. Loss of electrons results in the increase in oxidation number of its atom / atoms is called oxidation reaction.
- v. Gain of electron or decrease in oxidation number of its atom / atoms is known as electronation.
- vi. In metal-metal ion electrode, metal (M) immersed in the solution containing metal ions (M^{n+} ions).
- vii. Unit of electrode potential is volt per meter (V/m).
- viii. Standard electrode potential is denoted by E.
- ix. The tendency of the electrode in a half-cell to get reduced over to gain electrons is reduction electrode potential.
- x. If E° is positive, the reaction will be thermodynamically feasible if value of ΔG° is negative.
- xi. Nernst equation is

$$(E_{\text{red}})_{\text{elec}} = (E^\circ_{\text{red}})_{\text{elec}} - \frac{2.303RT}{nF} \log \frac{\text{Conc. of reactants}}{\text{Conc. of products}}$$
- xii. The substance which has a (+) ve value of E°_{red} has a tendency to gain electrons to undergo reduction and hence is capable of acting as an oxidizing agent in aqueous solution.
- xiii. Since E°_{red} value increases down the electro-chemical series, the reducing power of the reducing agents increases in the series.
- xiv. Redox reactions are irreversible in nature.
- xv. In Latimer diagram, the most highly reduced form of an element is written on the left and the most highly oxidized species written on the right side of the horizontal line.
- xvi. The most stable oxidation state lies lowest in the Frost diagram.

8.9.3. Long answer questions

- i. What is electrochemical series? Discuss its applications.

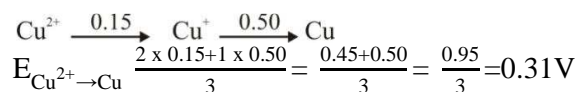

xii. Latimer Diagram of iron is:

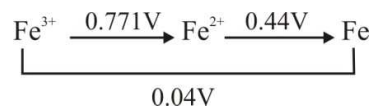

How would you derive the potential for iron?

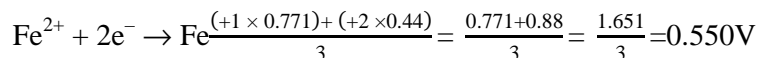
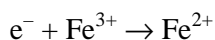

xiii. The Latimer diagram for manganese system is:-

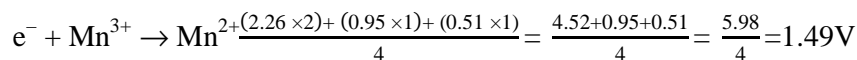
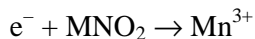
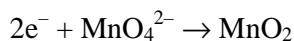

xiv. Show that disproportionation of H_2O_2 into O_2 and H_2O is spontaneous under acidic conditions. Given that:

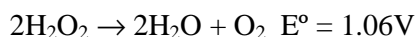
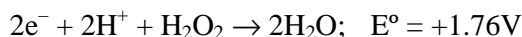
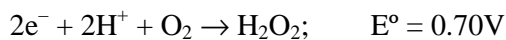

8.10. ANSWERS

8.10.1. Fill in the blanks

- i. reduced, oxidized
- ii. oxidation number
- iii. oxidation
- iv. reduction
- v. oxidation number
- vi. gain, lose
- vii. oxidation electrode
- viii. reduction
- ix. $\Delta G^\circ = -nE^\circ F$
- x. Latimer
- xi. Disproportionation
- xii. Ebsworth
- xiii. Pourbaix
- xiv. Frost
- xv. Comproportionation
- xvi. autooxidation

8.10.2. True (T) or False (F)

- i. T
- ii. F
- iii. F
- iv. T
- v. T
- vi. F
- vii. F
- viii. F
- ix. T
- x. T
- xi. F
- xii. T
- xiii. F
- xiv. F
- xv. F
- xvi. T

UNIT 9- ACIDS AND BASES

CONTENTS:

- 9.1 Objectives
- 9.2 Introduction
- 9.3 General concept of acids and bases
- 9.4 Theory of acids and bases
 - 9.4.1 Arrhenius theory
 - 9.4.2 Bronsted-Lowry concept of acids and bases
 - 9.4.3 Lux-Flood concept
 - 9.4.4 Solvent system
 - 9.4.5 Lewis concept of acids and bases
- 9.5 Relative strength of acids and bases
- 9.6 Summary
- 9.7 Terminal questions
- 9.8 Answers

9.1 OBJECTIVES

The main goal of this Unit is to broaden your understanding about the following issues:

- Definitions of acids and bases,
- Different theories of acids and bases,
- Acid and base strength,
- Periodic variations of acidic and basic properties,

9.2 INTRODUCTION

We all know that acids and bases play an essential and important role in our everyday life. The knowledge of acid/base chemistry helps in classifying daily household substances and items. A substance can be classified as an acid or a base

depending on certain properties. There are several theories to define and classify acids and bases that include Arrhenius theory, Bronsted-Lowry acid/base concept, Lux-flood acid/base theory and Lewis acid-base concept. The strength of acids and bases can be determined by measuring pH values of solutions. Every theory of acid and base shows some advantages and some limitations to overcome; the drawback of each theory. A new theory was proposed which was observed to be more advanced as compared to the previous one. This unit will throw light on different theories of acids/bases, their drawbacks and relative strengths of acids and bases.

9.3 GENERAL CONCEPT OF ACIDS AND BASES

In general, acids and bases can be classified on the basis of their properties. The basic concept of acids and bases can be summarized as follows:

Acids:

- They are sour in taste.
- They react with some metals and produce hydrogen:

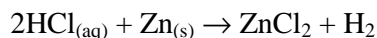

- They react with carbonate (Na_2CO_3) and bicarbonate (NaHCO_3) and produce CO_2 :

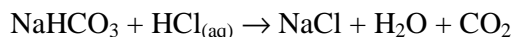

- Solution of acids in water conducts electricity.
- They change the colour of litmus from blue to red.

Base:

- They have bitter taste.
- They change colour of litmus from red to blue.
- They are slippery in nature.
- Aqueous base solution conducts electricity.

9.4 THEORY OF ACID AND BASES

The different theories to define acids and bases are discussed along with their advantages and drawbacks in this section.

9.4.1. Arrhenius theory (Water system concept, 1884):

In 1884, the Swedish chemist Arrhenius defined acid as the species which ionize in water to produce H^+ ion or (H_3O^+ ions) and bases as the substances that ionize in water to produce OH^- ions. For example,

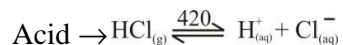

The H^+ ion produced is always associated with a water molecule to form H_3O^+ (aq) (hydronium) ion. Hence, Arrhenius acids are called as proton donors / hydrogen ion donors / hydronium ion donors. The complete reaction will be –

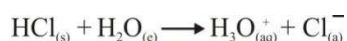

9.4.2. Bronsted–Lowry acids and bases (Protonic concept, 1923):

Arrhenius's definitions of acids and bases are limited to aqueous solutions. Hence, Bronsted in 1923 proposed that a substance capable of donating a proton to any substance is acid and a base can be defined as a species capable of accepting proton from any other substance.



Bronsted acid



Bronsted base

There are three types of acids and bases according to Bronsted-Lowry (Table 9.1).

Acids:

(i) Molecular acids

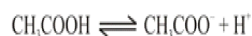
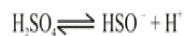
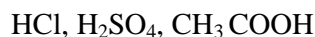

(ii) Anion acids

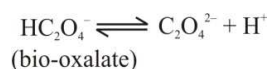
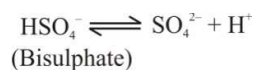

(iii) Cation acids

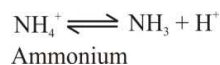
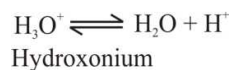
**Bases:**

(i) Molecular bases

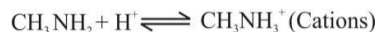
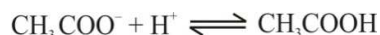
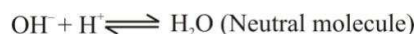
(ii) Anion bases (OH^- , S^{2-} , CO_3^{2-} , Cl^- , Br^- , NO_3^-)

(iii) Cationic bases

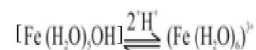
**Acid-Base Neutralization reaction:**

According to Arrhenius concept, acid-base neutralization reaction takes place in water, where a compound containing or making available H_3O^+ (or H^+) ions (acid) combines with a compound containing or making available OH^- ions (base) to form the salt and water:

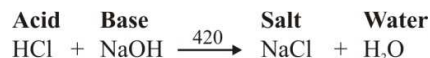
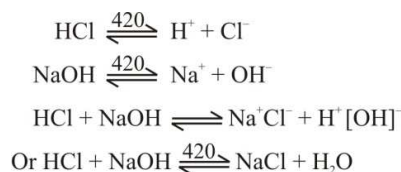
**Mechanism:**

This reaction is also known as salt formation reaction because salt formation takes place in this reaction.

Application (advantages) of Arrhenius concept:

- (i) Aqueous solutions of non-metallic oxides (e.g. CO₂, SO₂, SO₃, N₂O₃, N₂O₅, P₄O₆, P₄O₁₀ etc.) are acidic in nature, since they give H⁺ ions in water:



- (ii) Aqueous solutions of metallic oxides (e.g. CaO, Na₂O etc.) and the compounds like NH₃, N₂H₄, NH₄OH etc. are basic, since these substances give OH⁻ ions in aqueous solution:



- (iii) The strength of an acid (HA) and a base (BOH) can be expressed quantitatively in terms of the ionization (or dissociation) constant of the acid and base in aqueous solution.

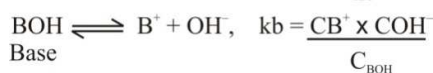
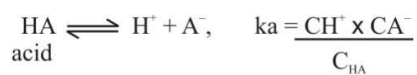

- (iv) The catalytic property of acids in many reactions can be explained because of H⁺ ions that become available from the acid in aqueous medium.

Limitations of Arrhenius concept:

- (i) According to this concept, the acid or base property of a substance is not supposed to inherit in the substance itself, but depends on its aqueous solution. For example, HCl is an acid, only when it is dissolved in water, but it is not considered as an acid in its gaseous state.
- (ii) According to this concept, acid base neutralization reactions take place only in water and hence can't explain the reactions that occur in other solvents or in the gas phase. For example, the formation of NH₄Cl_(s) by the combination of NH_{3(g)} and HCl_(g) cannot be explained by Arrhenius concept.

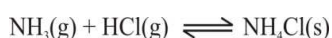

- (iii) According to this concept, acids and bases undergo dissociation only in water (aqueous solvent). Thus, it is unable to explain the dissociation of acids and bases in non-aqueous solvents like liq. NH₃, liq. SO₂ etc.

Conjugate acid results from the addition of proton to a base

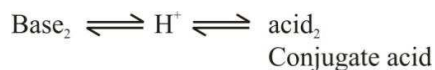

An acid base pair which is different by a proton is called conjugate acid base pair.

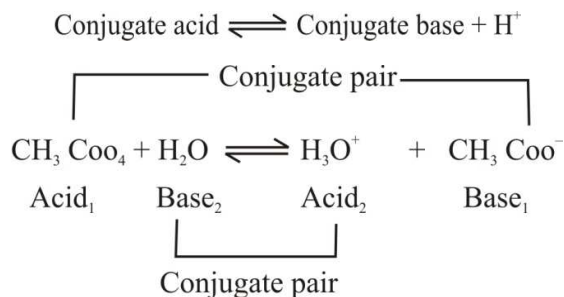

The sum of these two reactions is



Therefore, any acid-base reaction involves two acids and two bases. These acids and bases are called conjugate pairs.

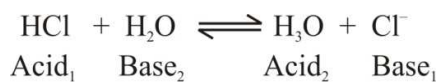

Relative strength of conjugate acid – base pairs

Strong acids	{	Acid	Conjugate base	↓ Increasing base Strength
		HClO ₄	ClO ₄ ⁻	
		HI	I ⁻	
		HBr	Br ⁻	
		HCl	Cl ⁻	
		H ₂ SO ₄	HSO ₄ ⁻	
		HNO ₃	NO ₃ ⁻	

Weak acids	{	H ₃ O ⁺	H ₂ O
		HSO ₄ ⁻	SO ₄ ²⁻
		HF	F ⁻
		HNO ₂	NO ₂ ⁻
		HCOOH	HCOO ⁻
		CH ₃ COOH	HCOO
		NH ₄ ⁺	NH ₃
		HCN	CN ⁻



- Acids stronger than H_3O^+ , react with water to produce H_3O^+ and their conjugate bases.

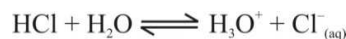

- Acids weaker than H_3O^+ , react with water to a much smaller extent. Bases like O^{2-} (oxide) stronger than OH^- , react with water to produce OH^- .

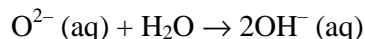

Therefore, oxide ion does not exist in solution.

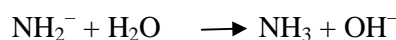

Advantages of Bronsted–Lowry Concept:

1. This concept can explain the acidic/basic nature of a substance in aqueous (H_2O) as well as in other protonic solvents like liq. NH_3 , liq. HF .
2. This concept also explains acid base reaction taking place in gaseous phase.

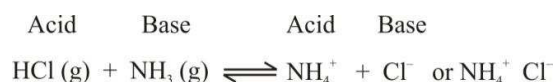

Limitations of Bronsted–Lowry concept:

This concept cannot explain the acid-base reactions taking place in non-protonic solvents, like liq. SO_2 , liq. BF_3 , BrF_3 , AlCl_3 , POCl_3 etc. in which no proton transfer takes place.

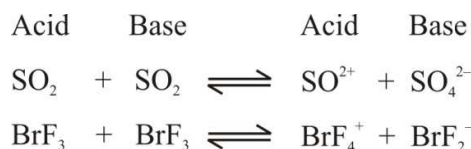

9.4.3 Lux-Flood concept

According to Lux-Flood concept, the base is an oxide donor and the acid is an oxide acceptor. Lux-Flood definition is useful for limited systems such as molten oxides.

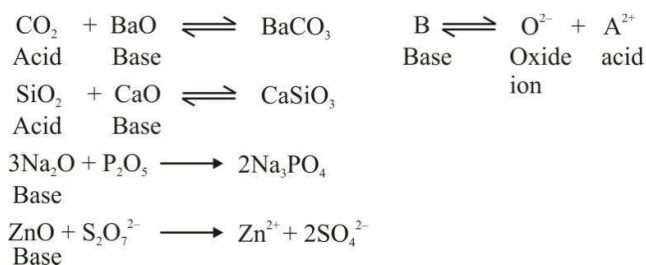

The Lux-Flood oxide transfer concept of acid-base reactions can be extended to any negative and positive ion species. Base is the species that can form negatively charged species and acid is the species that can produce positively charged species.

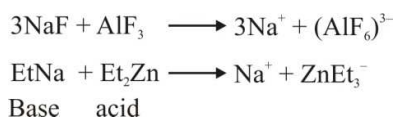

9.4.4 Solvent system (auto-ionization) concept (1928)

The concept was introduced by Franklin in 1905 and was extended by Cady-Esley in 1928. The definition of acids and bases given by this concept can be applied for protonic as well as for non-protonic solvents. According to this concept, the solvents usually undergo self ionization (auto-ionization) and give rise to cations and anions which are called solvent cations and solvent anions, respectively. The substances which form solvent cations when dissolved in that solvent are called acids while the substances which give solvent anions when dissolved in that solvent are called bases. We can now also conclude that solvent cations can also be called acid cations and solvent anions can also be called base anions.

Auto-ionization of water –

Water (H₂O) undergoes self-ionization in the following three ways:

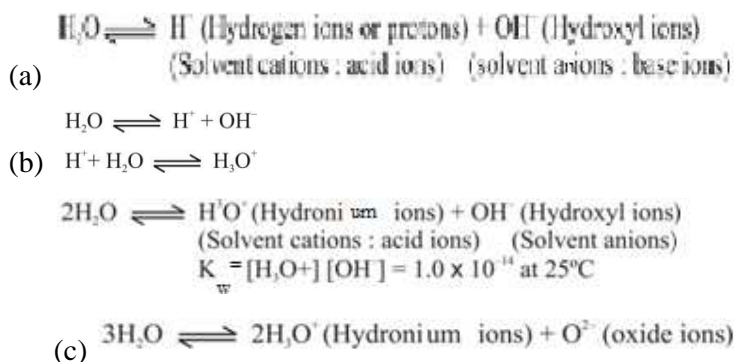

These three different modes of ionization suggest that, according to the solvent system concept, the substance that gives H⁺ or H₃O⁺ ions in water, act as acid in

aqueous solution, while the substances which furnish OH^- or O^{2-} ions in water, behave as bases.

HCl gives H^+ or H_3O^+ ions in water, hence; it behaves as an acid in aqueous solution.

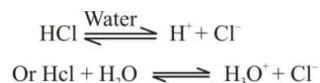

Similarly, NaOH, which furnish OH^- ions in its aqueous solution, acts as a base.



Likewise, for a solvent system of BrF_3 , the autoionization reaction is-

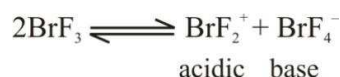

Hence, according to solvent system concept, the substance which can give BrF_2^+ in BrF_3 is acid and the substance which can form BrF_4^- is base.

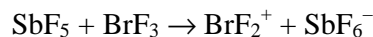

Acid

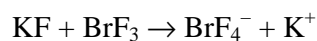

Base

Advantages of solvent system concept:

1. The definition of acids and bases given by solvent system concept can be used for both protonic (e.g. H_2O , NH_3 etc.) as well as non-protonic (e.g. SO_2 , SOCl_2 etc.) solvents.
2. The definition is applicable for aqueous (H_2O) as well as non-aqueous solvents (NH_3 , HF , H_2SO_4 etc).

Disadvantages:

1. The definition of acids and bases is based on the nature of the solvent cation and solvent anion obtained by auto-ionization of the solvent.
2. Acid base reaction taking place in the absence of a solvent can't be explained, i.e., acid-base reaction takes place only in presence of solvent.
3. The concept can't account for the acid-base reaction occurring in non-ionizing solvents like C_6H_6 , CHCl_3 etc.

9.4.5 Lewis concept: Electron pair acceptor-donor concept (1923)

According to G.N. Lewis, a Lewis acid is an electron pair acceptor and a Lewis base is an electron pair donor.

Lewis acid	Lewis base
Electrophile	Nucleophile
Contain vacant orbitals	Contain lone pair of electrons
Example – BeF_2 , BH_3 , BF_3 etc.	Example – NH_3 , H_2O , H^- etc.

Neutralization reaction according to Lewis concept:

- Lewis acid reacts with Lewis base and forms a compound which is called adduct or complex compound.
- The compound contains (Lewis base – Lewis acid) co-ordinate bond.
- Lewis acid + Lewis base \rightarrow Adduct
 $\text{BF}_3 + \text{:NH}_3 \rightarrow [\text{NH}_3 \rightarrow \text{BF}_3]$

Examples of Lewis acids:

- Molecules whose central atoms have vacant p-orbital or incomplete octet of electrons in its valence shell.

Examples –

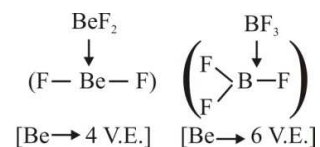

The Arrhenius, Bronsted-Lowry and solvent system neutralization reactions can be compared as follows:-

Arrhenius: acid + base \rightarrow salt + water

Bronsted-Lowry: acid₁ + base₂ \rightarrow base₁ + acid₂

Solvent system: acid + base \rightarrow solvent

Lewis system : acid + base \rightarrow adduct / coordination compound.

- Molecules whose central atoms have vacant d-orbitals in their valence shell.
e.g. AlF_3 , AlCl_3 , GeX_4 , TeCl_4 , SF_4 , SbF_3 etc.
- Molecules whose central atom is linked with more electronegative atom by double bonds.

e.g.

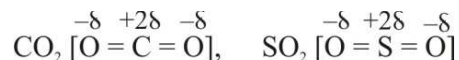

4. Simple cations, with low lying empty orbitals.

e.g. Ag^+ , Cu^{2+} , Cd^{2+} etc.

5. Elements which have a sextant of electrons in their valence shell.



Examples of Lewis base:

1. Molecules whose central atom has one or more unshared electron pairs (lone pair of electrons), e.g.



2. Molecules containing C = C double bond – ???

3. Halides, e.g. – XeF_2 , XeF_4 , CsF , CoCl_2 etc.

Pearson's classification of Lewis acids and Lewis bases into hard and soft acids and bases.

R. G. Pearson (1963) has classified the Lewis acids and Lewis bases as hard and soft acids and bases

Third categories whose characteristics are intermediate between those of hard and soft acids/bases are called borderline acids/bases.

Hard acids	Soft acids
d-orbitals are either vacant or non-existent	Nearly full d-orbitals
Smaller in size	Larger in size
Not so easily polarizable	Easily polarizable
These are mostly light metal ions generally associated with high positive oxidation state.	These are mostly heavy metal ions generally associated with low (or even zero) positive oxidation state.

Hard Acids	Borderline Acids	Soft Acids
H^+ , Li^+ , Na^+ , K^+ , Be^{2+} , Ca^{2+} , Sr^{2+} , Mn^{2+} , Al^{3+} , Ga^{3+} , In^{3+} , La^{3+} , Lu^{3+} , Cr^{3+} , Co^{3+} , Fe^{3+} , As^{3+} , Si^{4+} , Ti^{4+} ,	Fe^{2+} , Co^{2+} , Ni^{2+} , Cu^{2+} , Zn^{2+} Pb^{2+} , Sn^{2+} , Sb^{3+} , Bi^{3+} ,	Cu^+ , Ag^+ , Au^+ , Tl^+ , Hg^+ , Pb^{2+} , Cd^{2+} , Pt^{2+} , Hg^{2+} , Pt^{4+} , TI^{3+} , BH_3 ,

U ⁴⁺ , Ce ³⁺ , Sn ⁴⁺ , VO ²⁺ , UO ₂ ²⁺ , MoO ₃ ³⁺ , BF ₃	Rh ³⁺ , SO ₂ , NO ⁺ , GaH ₃	GaCl ₃ , InCl ₃ , carbenes π - acceptor ligands I ⁺ , Br ⁺ , O, Cl, Br, I, N Zero valent metal atoms.
--	---	---

Hard bases	Soft bases
Donor atoms having low polarisabilities and high electronegativity	Donor atoms that can be easily polarized and have low electronegativity.

Hard Bases	Borderline Bases	Soft Bases
H ₂ O, OH ⁻ , F ⁻ , CH ₃ COO ⁻ , PO ₄ ³⁻ , SO ₄ ²⁻ , Cl ⁻ , CO ₃ ²⁻ , ClO ₄ ⁻ , NO ₃ ⁻ , ROH, RO ⁻ , R ₂ O, NH ₃ , NH ₂ , N ₂ H ₄	C ₆ H ₅ NH ₂ , C ₆ H ₅ N, N ₃ ⁻ , NO ₂ , SO ₃ ²⁻ , N ₂ , Br ⁻	R ₂ S, RSH, RS ⁻ , I ⁻ , SCN ⁻ , S ₂ O ₃ ²⁻ , R ₃ P, R ₃ As, CN ⁻ , RCN, CO, C ₂ H ₄ , C ₆ H ₆ , H ⁻

According to HSAB principle, hard acids form stable complexes with hard bases and soft acids with soft bases.

Utility of Lewis Concept:

1. This concept includes those reactions also in which no protons are involved.
2. It is more significant than Bronsted – Lowry concept because according to this concept, acid-base behavior is independent of solvent's presence or absence.
3. It explains basic properties of metallic oxides and acidic properties of non-metallic oxides.
4. This concept also explains gas phase, high temperature and non-solvent reactions.

Limitations:

1. It is not possible to arrange Lewis acids and Lewis bases in order of their acid or base strength.
2. Protonic acids like H₂SO₄ and HCl are not covered under Lewis concept, as they do not establish a covalent bond by accepting a pair of electron (which a Lewis acid ought to).
3. According to this concept, acid-base reaction should be fast but it is not so in actual practice for many reactions due to kinetic factors.

4. The reactions catalyzed by Lewis acids are generally not catalyzed by the protonic acids.

Usanovich concept (1939):

Acid

- An acid is any chemical species which reacts with a base.
- It gives up cation or accepts anions or electrons.

Base

- A base is a species which reacts with acids.
- It gives up anion or electrons or combines with cations.

All the oxidizing agents are acids and the reducing agents as bases.

Example –

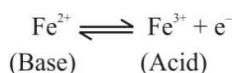

Limitations:

This concept is very general and all chemical reactions are to be considered.

9.5. Relative strengths of acids and bases

9.5.1. Acidity and basicity of binary hydrogen compounds

- Higher the values of K_a and K_b , stronger the acid or base
- Higher the pK_a or pK_b values, weaker the acid or base.
- The greater bond strength, less acidic is the hydride. On descending a group, the change in bond strength is greater than the change in the decreasing electronegativity.
- In a period from left to right, the change in electronegativity is greater than the changes in bond strength and the trend of electronegativity determines the trend in acidity.

Increasing order of acid strength as a result of
increase in electronegativity

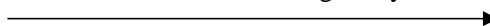

Increasing order of acid strength as a result of decrease in bond energy ↓	CH ₄ < NH ₃ < H ₂ O < HF
	pK _a 58 35 16 3
	Bond energy 414 389 464 565
	(kJ/mole)
	PH ₃ < H ₂ S < HCl
	pK _a 27 7 -7
	Bond energy 368 431
	(kJ/mole)
	H ₂ Se < HBr
	pK _a 3 -9
	Bond energy 305 364
	(KJ/mole)
	H ₂ Te < HI
	pK _a 3 -10
	Bond energy 238 299
	(KJ/mole)

9.5.2. Inductive effect (I-effect)

The strength of acids and bases can be explained by inductive effect. In case of electronegative groups, due to -I effect, availability of electrons on the central metal atom decreased and thus, basicity of a base decreased. Electron donor groups (+I effect) like methyl (-CH₃) group, increase electron density on central atom, thus, increase its basicity. In case of aliphatic amines, steric factors are responsible for weak basicity of tertiary amine.

- PF₃ is weaker base than PH₃.
- Base strength order NHMe₂ > NH₂Me > NMe₃ > NH₃.
- Boron halides do not follow this argument, acid strength BF₃ < BCl₃ < BBr₃. In such cases, the atom with empty orbitals (like Cl and Br), receive electrons from filled valence orbitals (in boron, all the four orbitals are filled), thus, create a double bond between boron and halogen atom and boron atom become more electron deficient. Bromine can more easily receive electrons from boron as compared to chlorine. Thus, BBr₃ is more acidic as compared to BCl₃.

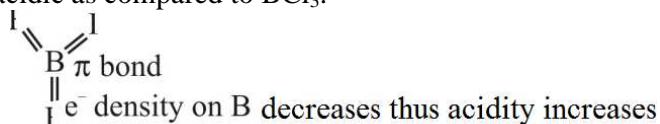

9.5.3. Strength of oxoacids (Effect of electronegativity)

A) Presence of electronegative atoms tends to attract the shared pair of e^- towards themselves and thus, dissociation of O – H bond becomes easier and the acid will be stronger.

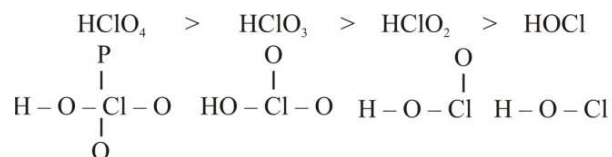

Order of acid strength

In HClO_4 , the presence of maximum number of electronegative oxygen atoms increases its acidity. \longrightarrow

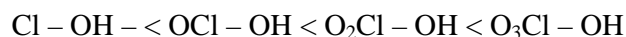

The other reason for the highest acidity of HClO_4 is that the negative charge after removing hydrogen can distribute over four oxygen atoms.

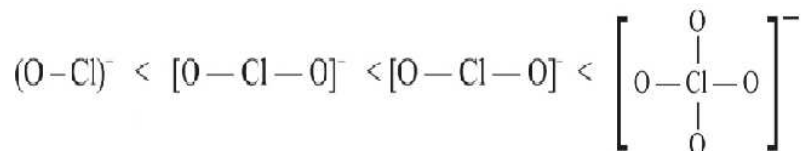

Maximum stability of ClO_4^- due to $-ve$ charge distribution in four oxygen atoms, so minimum attraction of H^+ for distributed $-ve$ charge and H^+ can be removed easily. While, in case of OCl^- , $-ve$ charge delocalized on only one oxygen atom. Hence, shows minimum stability.

B) Among HClO , HBrO and HIO , HClO is the most acidic in nature.



Electronegativity of I is lowest. Hence, the acidity of HIO will be the least.

C) For oxoacids of phosphorus, having more than one ionizable hydrogen, the pK_a value increases with decrease in the number of ionizable hydrogen.

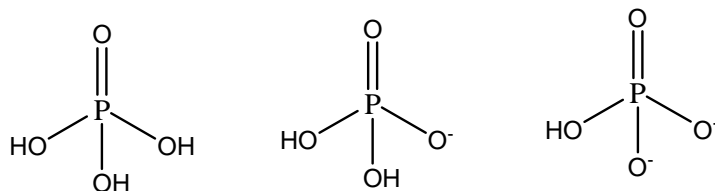

	H_3PO_4	H_2PO_4^-	HPO_4^{2-}
pK	2	7	12

The negative charge of the conjugate base is spread over all the nonhydrogenated oxygens. The larger the number of these oxygen atoms, the more stable and weaker the conjugate base and stronger the hydrogenated acid.

D) Acidity of cations in aqueous solution:

Metal ions with higher charges and smaller radii are stronger acids. The order of acidic strength is (Hydrated ions) alkali metals < alkaline earth metals < +3 < +4 (transition metals). High positive charge promotes more hydrogen ion dissociation:

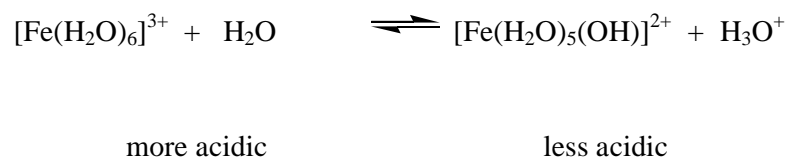

Solubility of metal hydroxide is also a measure of cation acidity. The stronger cationic acid, the less soluble the hydroxide. Transition metal +3 ions are acidic enough to form hydroxides.

- Higher charged ions are so strong acids in aqueous solutions that they exist only as oxygenated ions

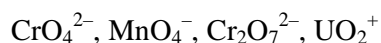

- $[\text{Ni}(\text{OH})_4]^{2-}$ is a stronger base than $[\text{Ni}(\text{OH})_4]^-$ ion

Acidity increases with increase of positive charge and basicity increases with increase in negative charge.

E) Steric effects:

Steric effects also influence acid-base behavior. Reactions of series of substituted pyridines with hydrogen ions show the following order of base strength:

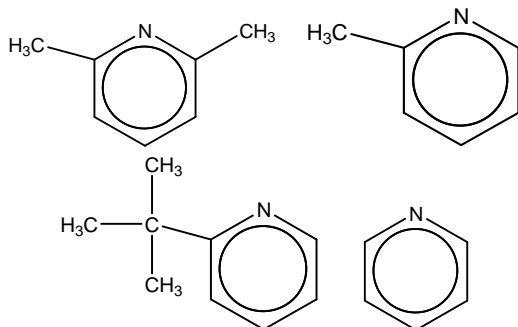

2,6-dimethylpyridine > 2-methylpyridine > 2-tert-butylpyridine > pyridine

9.6 SUMMARY

A compound may be acid or base on the basis of certain properties. There are different theories which classify and define the compounds into acids and bases. Some of the important theories are summaries below.

- According to the **Arrhenius concept**, acids are the compounds that give off H⁺ ions in aqueous medium and **bases** are the compounds that release OH⁻ ions in aqueous medium.
- The **Bronsted-Lowry acids** are the compounds that give off H⁺ ions to the other substances and **bases** are the compounds that accept H⁺ from other substances. They also bring the concept of conjugate acids and bases.
- **Lewis acids** are the compounds that are electron deficient and can easily accept an electron pair while **bases** are the electron efficient compounds and can donate lone pair of electrons to other substances (Lewis acids).
- According to the **solvent concept**, **acids** are the positive species donor while **bases** are negative species donor in a solvent system.
- **Lux-Flood acids** are those compounds which can accept oxide ion and bases are oxide ion donor.
- In general acids have pH values in between 0 – 6.9 (<7), bases between 7.1 – 14 (>7) and neutral substances have a value of 7.
- The strength of acids and bases can be defined on the basis of pK_a and pK_b values. Higher the pK_a value, lower its acidity and similarly higher the pK_b values, weaker will be the base and *vice-versa*.

- The different factors that affect acidity or basicity are inductive effect, resonance, steric effect, electronegativity and charge on the species.
- The hydrides of 2nd period viz. CH₄, NH₃, H₂O and HF become more acidic as we move from CH₄ to HF. As the basicity of their conjugate base decreases from CH₃⁻ to F⁻, the acidity of their conjugate acid increases from CH₄ to HF.
- Among the hydroacids of V or 15 Group elements viz. NH₃, PH₃, AsH₃, SbH₃, BiH₃, with the increase in size and decrease in electronegativity from N to Bi, there is decrease in electron density, thus basic character decreases.



Decreasing order of basic character

- The strength of hydrides as acids increases in the order

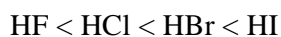

- For oxoacids containing the central atom, the acidity increases with increasing oxidation number.



Hence, basic strength of their conjugate base is –

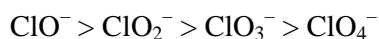

- The acidic character of oxoacids of different elements in same oxidation state decreases with the increase in atomic number of the central atom.



- [Fe(H₂O)₆]³⁺ is stronger acid than [Fe(H₂O)₆]²⁺ due to increase in positive charge.

A) I Effect

Electron
withdrawing groups

↓(-I)
increases acidic
strength &
decreases
basic strength

Electron donating groups

↓ (+I)
Decreases acidic
Strength and
Increases basic strength

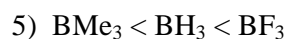
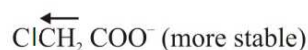
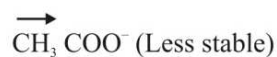
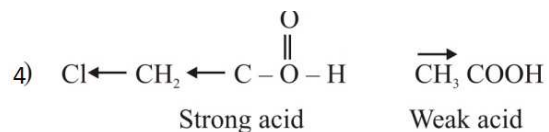
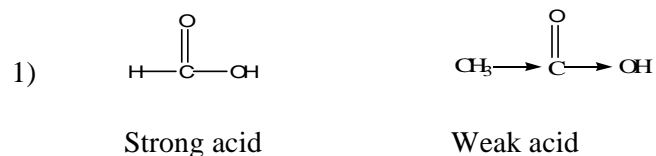

(B) Magnitude of -I effect (Order of acidic strength)

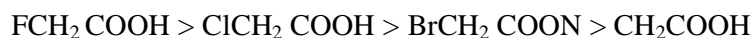

(C) Number of electron withdrawing groups

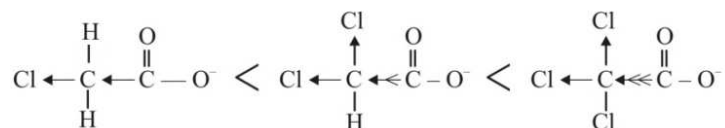
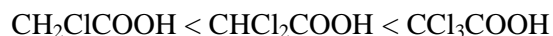

(D) Distance of electron withdrawing group from -COOH in aliphatic carboxylic acids

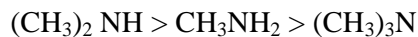
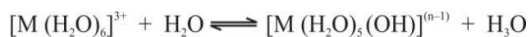

(E) Steric effect

**(F) Charge on species**

Charge to size ratio \rightarrow more polar the hydrated cation, weaker the O – H bond, more acidity.

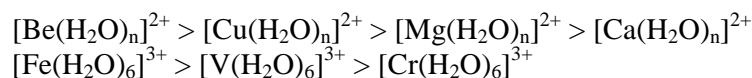
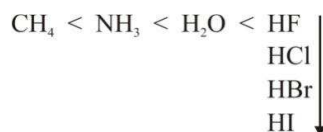
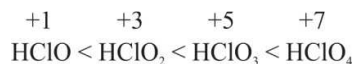
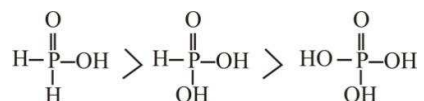
**(G) Effect of Electronegativity****(H) Oxidation no of the central atom****(I) Number of –OH groups per unhydroxyl O atom****(J) Resonance effects**

- $\text{C}_6\text{H}_5\text{COOH}$ more acidic as compared to CH_3COOH .
- $\text{C}_6\text{H}_4\text{NO}_2\text{COOH}$ {ortho (o-), meta (m-), para (p-)} are more acidic than $\text{C}_6\text{H}_5\text{COOH}$.

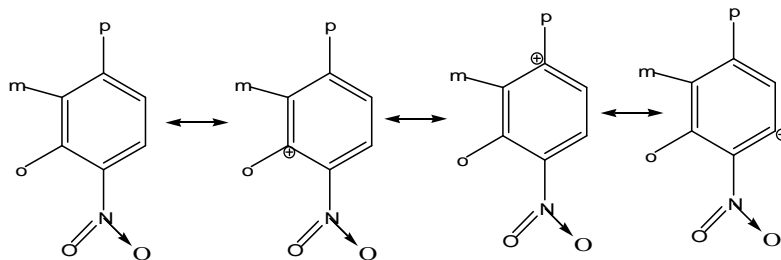

- The order of acidic strength of $C_6H_4NO_2COOH$ is

o-nitrobenzoic acid > p-nitrobenzoic acid > m-nitrobenzoic acid

- Phenol is more acidic as compared to C_2H_5OH .

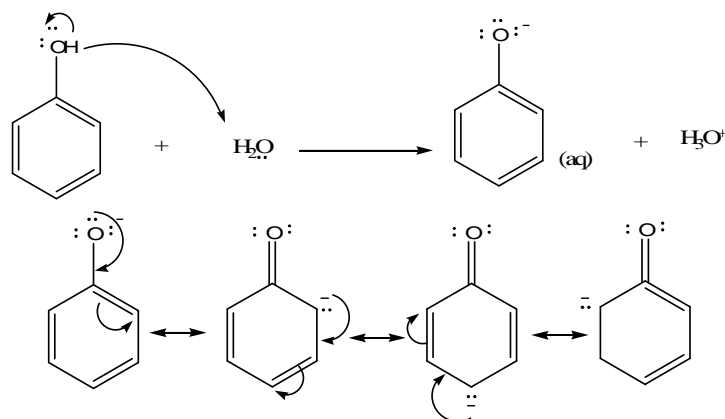

Resonance structure of phenoxide ion

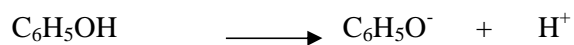

Less stable species

More stable



More stable species

Less stable

- Order of basicity of hydrides of fifth group is $NH_3 > PH_3 > A_5H_3 > SbH_3 > BiH_3$

As size of central metal increases, the lone pair occupies greater volume and hence, electron density around the central atom decreases. Therefore, the hydride with small sized central atom is more basic.

Bibliography

- t) Br. R. Puri, L. R. Sharma and K. C Kalia. *Principles of Inorganic Chemistry*, Milestone Publishers & Distributors, Meerut, 2013.
- u) G. S. Sodhi, *Textbook of Inorganic Chemistry*, Viva Books Private Limited, New Delhi, 2013.
- v) M. S. Yadav. *Quick Review in Inorganic Chemistry*, Anmol Publications Pvt. Ltd., New Delhi, 2004.
- Advanced Inorganic Chemistry*, Jagdamba Publishing Compan, New Delhi, 2011.
- x) R. L. Madan, *Chemistry for degree students, B.Sc. II year*, S. Chand & Company Ltd., New Delhi, 2011.
- y) S. Prakash, G. D. Tuli, S. K. Basu, and R. D. Madan. *Advanced Inorganic Chemistry*, Vol. I, S. Chand & Company Ltd., New Delhi, 2007.
- z) W. U. Malik, G. D. Tuli, and R. D. Madan. *Selected Topics in Inorganic Chemistry*, S. Chand Publication, Delhi, 2013.

9.7. TERMINAL QUESTIONS

9.7.1. Fill in the blanks

- i. In 1884, the Swedish chemist Arrhenius defined acid as the species which ionize in water to produce or ions.
- ii. Arrhenius's definitions of acids and bases are limited to.....
- iii. Hence, Bronsted in 1923 proposed that a substance capable of donating a proton to any substance is and a can be defined as a species capable of accepting proton from any other substance.
- iv. Aqueous solution of oxides is acidic.
- v. Aqueous solution of oxides and is basic.
- vi. The strength of an acid (HA) and a base (BOH) can be expressed quantitatively in terms of the constant.
- vii. A substance which acts both as an acid as well base in different reactions is called
- viii. also gave the concept of conjugate acid base pair.
- ix. Conjugate base is a species that remains when one has been removed from the acid.
- x. An acid base pair which is different by a proton is called acid base pair.
- xi. Acid stronger than H_3O^+ , react with water to produce H_3O^+ and their bases.
- xii. According to concept, the base is an oxide donor and the acid is an oxide acceptor.

- xiii. Base is the species that can form charged species and acid is the species that can produce charged species.
- xiv. Solvent system concept was introduced by in 1905 and was extended by in 1928.
- xv. According to solvent system concept, the substance which can give BrF_2^+ in BrF_3 is
- xvi. According to G. N. Lewis, a is an electron pair acceptor and a Lewis base is an electron pair donor.
- xvii. According to HSAB principle, hard acids form stable complexes with and soft acids with.....
- xviii. In Hard acids, d-orbitals are either or
- xix. Higher the pK_a or pK_b values, the acid or base.
- xx. PF_3 is base than PH_3 .
- xxi. Among HClO , HBrO and HIO , is the most acidic in nature.
- xxii. Metal ions with higher charges and smaller radii are acids.
- xxiii. Higher charged ions are so strong acids in aqueous solutions that they exist only as ions.

9.7.2. State True (T) or False (F)

- i. Solution of acids in water conducts electricity.
- ii. Arrhenius acids are called as proton donors / hydrogen ion donors / hydronium ion donors.
- iii. H_3O^+ is a Bronsted acid.
- iv. In the gas phase the formation of $\text{NH}_4\text{Cl}_{(s)}$ by the combination of $\text{NH}_{3(g)}$ and $\text{HCl}_{(g)}$ can be explained by Arrhenius concept.
- v. The molecules or ions that can act as Bronsted acids as well as Bronsted bases are called amphoteric substances.
- vi. Any acid-base reaction involves one acid and one base.
- vii. The substances which form solvent cations when dissolved in that solvent are called bases while the substances which give solvent anions when dissolved in that solvent are called acids.
- viii. Lewis acid reacts with Lewis base and forms a compound which is called adduct or complex compound.
- ix. Molecules whose central atom is linked with more electronegative atom by double bonds are Lewis acids.
- x. Pearson gave the classification of Lewis acids and Lewis bases into hard and soft acids and bases.

- xi. Base strength order of amine and substituted amines is $\text{NHMe}_2 < \text{NH}_2\text{Me} < \text{NMe}_3 < \text{NH}_3$.
- xii. $[\text{Fe}(\text{H}_2\text{O})_6]^{3+}$ is more acidic as compared to $[\text{Fe}(\text{H}_2\text{O})_5(\text{OH})]^{2+}$.
- xiii. $[\text{Ni}(\text{OH})_4]^-$ is more basic as compared to $[\text{Ni}(\text{OH})_4]^{2-}$.
- xiv. Order of basic strength of substituted pyridine is 2,6-dimethylpyridine > 2-methylpyridine > 2-t-butylpyridine

9.7.3. Long answer questions

- i. What are the general characteristics of acids and bases?
- ii. Discuss Arrhenius theory of acids and bases.
- iii. Write short notes on the following:
 - a. Conjugate acid and base
 - b. Neutralization reaction
 - c. Lux-Flood concept
 - d. Solvent system concept
- iv. Discuss Lewis acid and base concept
- v. Differentiate between hard and soft acids and bases.
- vi. How electronegativity affect acid and base strength?
- vii. Discuss strength of oxoacids.

9.8. ANSWERS

9.8.1. Fill in the blanks

- i. H^+ or H_3O^+
- ii. Aqueous solutions
- iii. acid, base
- iv. non-metallic
- v. metallic
- vi. ionization (or dissociation)
- vii. amproteric
- viii. Bronsted-Lowry
- ix. proton
- x. conjugate
- xi. conjugate
- xii. Lux-Flood
- xiii. negatively, positively

- xiv. Franklin, Cady-Esley
- xv. acid
- xvi. a Lewis acid
- xvii. hard bases, soft bases
- xviii. vacant, non-existent
- xix. stronger
- xx. weaker
- xxi. HClO
- xxii. Stronger
- xxiii. Oxygenated

9.8.2. True (T) or False (F)

- i. T
- ii. T
- iii. T
- iv. F
- v. T
- vi. F
- vii. F
- viii. T
- ix. T
- x. T
- xi. F
- xii. T
- xiii. F
- xiv. T